

MITSUBISHI

Mitsubishi Programmable Controller

MELSEC *L*series

MELSEC-L Temperature Control Module User's Manual

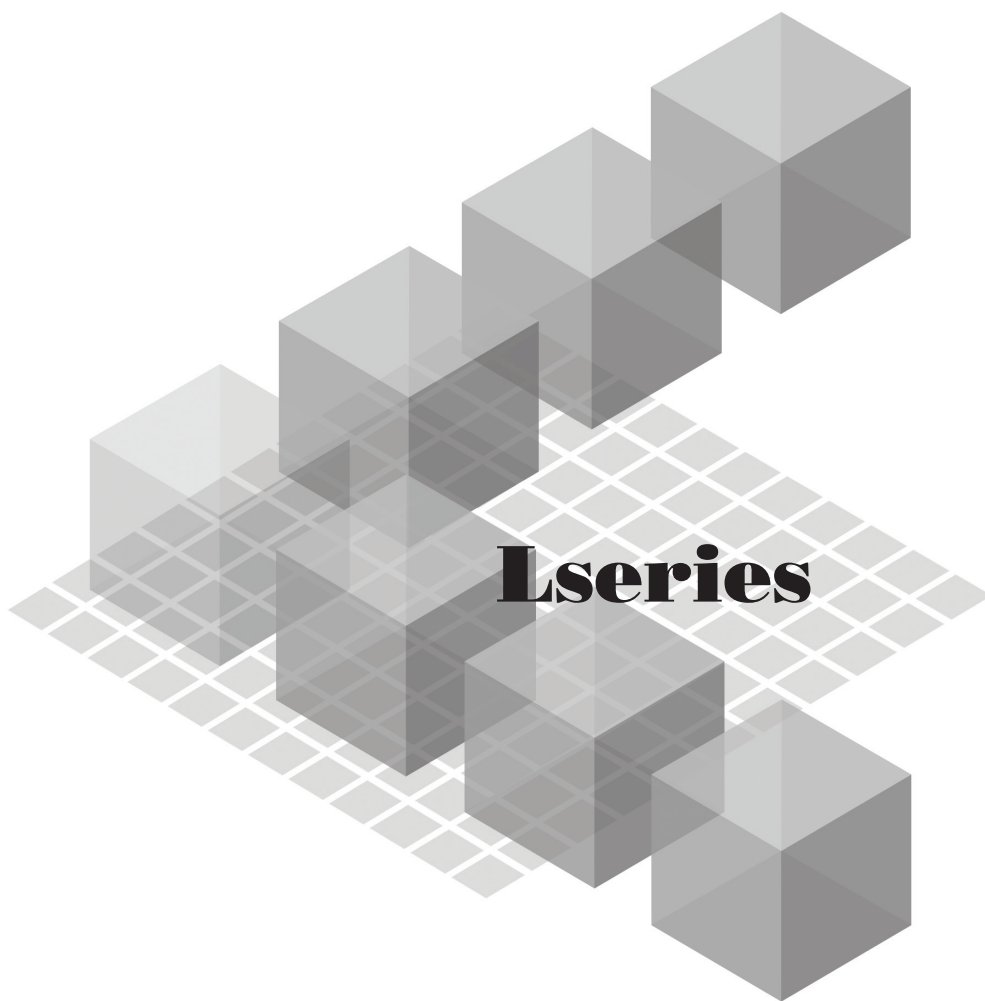

-L60TCTT4
-L60TCTT4BW
-L60TCRT4
-L60TCRT4BW

MODEL

● SAFETY PRECAUTIONS ●

(Read these precautions before using this product.)

Before using this product, please read this manual and the relevant manuals carefully and pay full attention to safety to handle the product correctly.

The precautions given in this manual are concerned with this product only. For the safety precautions of the programmable controller system, refer to the user's manual for the CPU module used.

In this manual, the safety precautions are classified into two levels: "⚠ CAUTION" and "⚠ WARNING".



Indicates that incorrect handling may cause hazardous conditions, resulting in death or severe injury.

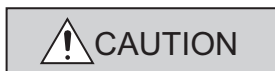

Indicates that incorrect handling may cause hazardous conditions, resulting in minor or moderate injury or property damage.

Under some circumstances, failure to observe the precautions given under "⚠ CAUTION" may lead to serious consequences.

Observe the precautions of both levels because they are important for personal and system safety.

Make sure that the end users read this manual and then keep the manual in a safe place for future reference.

[Design Precautions]

⚠ WARNING

- Do not write any data to the "system area" and "write-protect area" (R) of the buffer memory in the intelligent function module. Also, do not use any "use prohibited" signals as an output signal from the programmable controller CPU to the intelligent function module. Doing so may cause malfunction of the programmable controller system.

[Design Precautions]

⚠ CAUTION

- Do not install the control lines or communication cables together with the main circuit lines or power cables. Keep a distance of 100mm or more between them. Failure to do so may result in malfunction due to noise.

[Installation Precautions]

WARNING

- Shut off the external power supply (all phases) used in the system before mounting or removing a module. Failure to do so may result in electric shock or cause the module to fail or malfunction.

[Installation Precautions]

CAUTION

- Use the programmable controller in an environment that meets the general specifications in the Safety Guidelines provided with the CPU module or head module. Failure to do so may result in electric shock, fire, malfunction, or damage to or deterioration of the product.
- To interconnect modules, engage the respective connectors and securely lock the module joint levers. Incorrect interconnection may cause malfunction, failure, or drop of the module.
- Tighten the screw within the specified torque range. Undertightening can cause drop of the screw, short circuit or malfunction. Overtightening can damage the screw and/or module, resulting in drop, short circuit, or malfunction.
- Do not directly touch any conductive parts and electronic components of the module. Doing so can cause malfunction or failure of the module.

[Wiring Precautions]

WARNING

- After installation and wiring, attach the included terminal cover to the module before turning it on for operation. Failure to do so may result in electric shock.

[Wiring Precautions]

CAUTION

- Ground the FG terminal to the protective ground conductor dedicated to the programmable controller. Failure to do so may result in electric shock or malfunction.
- Tighten the terminal block screw within the specified torque range. Undertightening can cause short circuit, fire, or malfunction. Overtightening can damage the screw and/or module, resulting in drop, short circuit, fire, or malfunction.
- Prevent foreign matter such as dust or wire chips from entering the module. Such foreign matter can cause a fire, failure, or malfunction.
- A protective film is attached to the top of the module to prevent foreign matter, such as wire chips, from entering the module during wiring. Do not remove the film during wiring. Remove it for heat dissipation before system operation.
- Mitsubishi programmable controllers must be installed in control panels. Connect the main power supply to the power supply module in the control panel through a relay terminal block. Wiring and replacement of a power supply module must be performed by qualified maintenance personnel with knowledge of protection against electric shock. For wiring methods, refer to the MELSEC-L CPU Module User's Manual (Hardware Design, Maintenance and Inspection).

[Startup and Maintenance Precautions]

WARNING

- Do not touch any terminal while power is on. Doing so will cause electric shock or malfunction.
- Shut off the external power supply (all phases) used in the system before cleaning the module or retightening the terminal block screw. Failure to do so may result in electric shock.

[Startup and Maintenance Precautions]

CAUTION

- Do not disassemble or modify the module. Doing so may cause failure, malfunction, injury, or a fire.
- Shut off the external power supply (all phases) used in the system before mounting or removing a module. Failure to do so may cause the module to fail or malfunction.
- Tighten the terminal block screw within the specified torque range. Undertightening can cause drop of the component or wire, short circuit, or malfunction. Overtightening can damage the screw and/or module, resulting in drop, short circuit, or malfunction.
- After the first use of the product (module, display unit, and terminal block), the number of connections/disconnections is limited to 50 times (in accordance with IEC 61131-2). Exceeding the limit may cause malfunction.
- Before handling the module, touch a conducting object such as a grounded metal to discharge the static electricity from the human body. Failure to do so may cause the module to fail or malfunction.

[Disposal Precautions]

CAUTION

- When disposing of this product, treat it as industrial waste.

●CONDITIONS OF USE FOR THE PRODUCT●

- (1) Mitsubishi programmable controller ("the PRODUCT") shall be used in conditions;
 - i) where any problem, fault or failure occurring in the PRODUCT, if any, shall not lead to any major or serious accident; and
 - ii) where the backup and fail-safe function are systematically or automatically provided outside of the PRODUCT for the case of any problem, fault or failure occurring in the PRODUCT.

- (2) The PRODUCT has been designed and manufactured for the purpose of being used in general industries.

MITSUBISHI SHALL HAVE NO RESPONSIBILITY OR LIABILITY (INCLUDING, BUT NOT LIMITED TO ANY AND ALL RESPONSIBILITY OR LIABILITY BASED ON CONTRACT, WARRANTY, TORT, PRODUCT LIABILITY) FOR ANY INJURY OR DEATH TO PERSONS OR LOSS OR DAMAGE TO PROPERTY CAUSED BY the PRODUCT THAT ARE OPERATED OR USED IN APPLICATION NOT INTENDED OR EXCLUDED BY INSTRUCTIONS, PRECAUTIONS, OR WARNING CONTAINED IN MITSUBISHI'S USER, INSTRUCTION AND/OR SAFETY MANUALS, TECHNICAL BULLETINS AND GUIDELINES FOR the PRODUCT.

("Prohibited Application")

Prohibited Applications include, but not limited to, the use of the PRODUCT in;

- Nuclear Power Plants and any other power plants operated by Power companies, and/or any other cases in which the public could be affected if any problem or fault occurs in the PRODUCT.
- Railway companies or Public service purposes, and/or any other cases in which establishment of a special quality assurance system is required by the Purchaser or End User.
- Aircraft or Aerospace, Medical applications, Train equipment, transport equipment such as Elevator and Escalator, Incineration and Fuel devices, Vehicles, Manned transportation, Equipment for Recreation and Amusement, and Safety devices, handling of Nuclear or Hazardous Materials or Chemicals, Mining and Drilling, and/or other applications where there is a significant risk of injury to the public or property.

Notwithstanding the above, restrictions Mitsubishi may in its sole discretion, authorize use of the PRODUCT in one or more of the Prohibited Applications, provided that the usage of the PRODUCT is limited only for the specific applications agreed to by Mitsubishi and provided further that no special quality assurance or fail-safe, redundant or other safety features which exceed the general specifications of the PRODUCTS are required. For details, please contact the Mitsubishi representative in your region.

INTRODUCTION

Thank you for purchasing the Mitsubishi MELSEC-L series programmable controllers.

This manual describes the operating procedures, system configuration, parameter settings, functions, programming, and troubleshooting of the L series temperature control module L60TCTT4/L60TCTT4BW/L60TCRT4/L60TCRT4BW (hereafter abbreviated as L60TC4).

Before using this product, please read this manual and the relevant manuals carefully and develop familiarity with the functions and performance of the MELSEC-L series programmable controller to handle the product correctly.

When applying the program examples introduced in this manual to the actual system, ensure the applicability and confirm that it will not cause system control problems.

■Relevant modules: L60TCTT4, L60TCTT4BW, L60TCRT4, L60TCRT4BW

Remark

Operating procedures are explained using GX Works2. When using GX Developer, refer to  Page 419, Appendix 5.

.....

COMPLIANCE WITH EMC AND LOW VOLTAGE DIRECTIVES

(1) Method of ensuring compliance

To ensure that Mitsubishi programmable controllers maintain EMC and Low Voltage Directives when incorporated into other machinery or equipment, certain measures may be necessary. Please refer to the manual included with the CPU module or head module. The CE mark on the side of the programmable controller indicates compliance with EMC and Low Voltage Directives.

(2) Additional measures

To ensure that this product maintains EMC and Low Voltage Directives, please refer to the manual included with the CPU module or head module.

RELEVANT MANUALS

(1) CPU module user's manual

Manual name <manual number (model code)>	Description
MELSEC-L CPU Module User's Manual (Hardware Design, Maintenance and Inspection) <SH-080890ENG, 13JZ36>	Specifications of the CPU modules, power supply modules, display unit, SD memory cards, and batteries, information on how to establish a system, maintenance and inspection, and troubleshooting
MELSEC-L CPU Module User's Manual (Function Explanation, Program Fundamentals) <SH-080889ENG, 13JZ35>	Functions and devices of the CPU module, and programming

(2) Head module user's manual

Manual name <manual number (model code)>	Description
MELSEC-L CC-Link IE Field Network Head Module User's Manual <SH-080919ENG, 13JZ48>	Specifications, procedures before operation, system configuration, installation, wiring, settings, and troubleshooting of the head module

(3) Operating manual

Manual name <manual number (model code)>	Description
GX Works2 Version 1 Operating Manual (Common) <SH-080779ENG, 13JU63>	System configuration, parameter settings, and online operations (common to Simple project and Structured project) of GX Works2
GX Developer Version 8 Operating Manual <SH-080373E, 13JU41>	Operating methods of GX Developer, such as programming, printing, monitoring, and debugging

CONTENTS

SAFETY PRECAUTIONS	1
CONDITIONS OF USE FOR THE PRODUCT	4
INTRODUCTION	5
COMPLIANCE WITH EMC AND LOW VOLTAGE DIRECTIVES	6
RELEVANT MANUALS	7
MANUAL PAGE ORGANIZATION	12
TERMS	14
PACKING LIST	15
<hr/>	
CHAPTER 1 WHAT CAN BE DONE WITH A TEMPERATURE CONTROL MODULE	16
<hr/>	
1.1 Use	16
1.2 Features	18
1.3 The PID Control System	21
1.4 About the PID Operation	23
1.4.1 Operation method and formula	23
1.4.2 The L60TC4 actions	24
1.4.3 Proportional action (P-action)	25
1.4.4 Integral action (I-action)	26
1.4.5 Derivative action (D-action)	27
1.4.6 PID action	28
<hr/>	
CHAPTER 2 PART NAMES	29
<hr/>	
CHAPTER 3 SPECIFICATIONS	31
<hr/>	
3.1 General Specifications	31
3.2 Performance Specifications	32
3.2.1 Number of parameters to be set	34
3.2.2 Type of usable temperature sensors, temperature measurement range, resolution, and effect from wiring resistance of 1 ohm.	36
3.2.3 Sampling cycle and control output cycle	38
3.3 Function List	39
3.4 I/O Signal List	42
3.5 Buffer Memory List	44
<hr/>	
CHAPTER 4 PROCEDURE BEFORE OPERATION	79
<hr/>	
CHAPTER 5 SYSTEM CONFIGURATION	81
<hr/>	
5.1 Total Configuration	81
5.2 Applicable Systems	82
5.3 Precautions for System Configuration	83
<hr/>	
CHAPTER 6 INSTALLATION AND WIRING	84
<hr/>	
6.1 Installation Environment and Installation Position	84
6.2 Terminal Block	85
6.3 Wiring precautions	92

6.4	External wiring	93
6.4.1	L60TCTT4	93
6.4.2	L60TCTT4BW	96
6.4.3	L60TCRT4	99
6.4.4	L60TCRT4BW	102
6.5	Heater disconnection detection wiring and setting example for three-phase heater	105
6.6	Unused Channel Setting	106

CHAPTER 7 VARIOUS SETTINGS	107
-----------------------------------	------------

7.1	Addition of Modules	107
7.2	Switch Setting	108
7.3	Parameter Setting	110
7.4	Auto Refresh	114
7.5	Auto Tuning	114
7.6	Sensor Correction	114

CHAPTER 8 FUNCTIONS	115
----------------------------	------------

8.1	Temperature Input Mode	116
8.1.1	Conversion enable/disable function	117
8.1.2	Temperature conversion method	117
8.1.3	Alert output function	120
8.2	Temperature Control Mode	125
8.2.1	Control Mode Selection Function	126
8.2.2	Control output setting at CPU stop error	128
8.2.3	Control method	129
8.2.4	Manual Reset Function	137
8.2.5	Manual Control	139
8.2.6	Control output cycle unit selection function	140
8.2.7	Auto tuning function	141
8.2.8	Simple Two-degree-of-freedom	153
8.2.9	Derivative Action Selection Function	154
8.2.10	Setting Change Rate Limiter Setting Function	155
8.2.11	Alert Function	157
8.2.12	RFB Limiter Function	171
8.2.13	Input/output (with another analog module) function	172
8.2.14	ON delay output function	174
8.2.15	Self-tuning function	175
8.2.16	Peak current suppression function	185
8.2.17	Simultaneous temperature rise function	190
8.2.18	Forward/reverse action selection function	203
8.2.19	Loop disconnection detection function	204
8.2.20	Proportional band setting function	206
8.2.21	Cooling method setting function	207
8.2.22	Overlap/dead band function	209
8.2.23	Temperature conversion function (using unused channels)	212
8.2.24	Heater disconnection detection function	215

8.2.25	Output off-time current error detection function	220
8.3	Common Functions	221
8.3.1	Temperature process value (PV) scaling function	221
8.3.2	Sensor compensation function	223
8.3.3	Auto configuration at input range change function	234
8.3.4	Buffer memory data backup function	235
8.3.5	Error history function	237
8.3.6	Module error history collection function	239
8.3.7	Error clear function	240

CHAPTER 9 DISPLAY UNIT	241
-------------------------------	------------

9.1	Display Unit	241
9.2	Menu Transition	241
9.3	Setting Value Change Screen List	243
9.4	Checking and Clearing Errors	248

CHAPTER 10 PROGRAMMING	250
-------------------------------	------------

10.1	Programming Procedure	250
10.2	When Using the Module in a Standard System Configuration	252
10.2.1	When using the L60TC4 as a temperature input module	252
10.2.2	Standard control (such as auto tuning, self-tuning, and error code read)	263
10.2.3	Standard control (peak current suppression function, simultaneous temperature rise function)	274
10.2.4	When performing the heating-cooling control	288
10.3	When the Module is Connected to the Head Module	298

CHAPTER 11 TROUBLESHOOTING	308
-----------------------------------	------------

11.1	Before Troubleshooting	308
11.2	Troubleshooting Procedure	308
11.3	Checks Using LEDs	310
11.3.1	When the RUN LED flashes or turns off	310
11.3.2	When the ERR. LED turns on or flashes	310
11.3.3	When the ALM LED turns on or flashes	311
11.4	Checks Using Input Signals	312
11.4.1	When Module READY flag (Xn0) does not turn on	312
11.4.2	When Error occurrence flag (Xn2) is on	312
11.4.3	When Hardware error flag (Xn3) is on	312
11.4.4	When the auto tuning does not start (CH□ Auto tuning status (Xn4 to Xn7) does not turn on)	312
11.4.5	When the auto tuning does not complete (CH□ Auto tuning status (Xn4 to Xn7) stays on and does not turn off)	313
11.4.6	When the self-tuning does not start (CH□ Auto tuning status (Xn4 to Xn7) does not turn on)	313
11.4.7	When Back-up of the set value fail flag (XnA) is on	313
11.4.8	When CH□ Alert occurrence flag (XnC to XnF) is on	313

11.5	Troubleshooting by Symptom	314
11.5.1	When the temperature process value (PV) is abnormal	314
11.6	Error Code List	315
11.7	Alarm Code List	318
11.8	Check the L60TC4 Status	321

APPENDICES	323
-------------------	------------

Appendix 1	Details of I/O Signals	323
Appendix 1.1	Input signal	323
Appendix 1.2	Output signal	330
Appendix 2	Details of the Buffer Memory	334
Appendix 3	How to Check the Serial Number and Function Version	416
Appendix 4	Differences with MELSEC-Q series Modules	417
Appendix 4.1	Differences with temperature control modules	417
Appendix 5	When Using GX Developer	419
Appendix 5.1	I/O assignment and intelligent function module switch setting	419
Appendix 5.2	Initial setting and auto refresh setting	422
Appendix 6	External Dimensions	423

INDEX	426
--------------	------------

REVISIONS	432
WARRANTY	433

MANUAL PAGE ORGANIZATION

In this manual, pages are organized and the symbols are used as shown below.

The following illustration is for explanation purpose only, and should not be referred to as an actual documentation.

Annotations for the manual page screenshot:

- "" is used for screen names and items.
- 1. shows operating procedures.
- ☞ shows mouse operations.*1
- [] is used for items in the menu bar and the project window.
- Ex. shows setting or operating examples.
- 📖 shows reference manuals.
- 📄 shows reference pages.
- Point shows notes that requires attention.
- Remark shows useful information.

Manual page content (Page 73):

CHAPTER 7 VARIOUS SETTINGS

7.1.1 Setting method

(1) Setting parameters

(a) Operating procedure

1. Open the "PLC Parameter" dialog box.
☞ Project window ⇨ [Parameter] ⇨ [PLC parameter]
2. Select the "I/O Assignment" tab.

Item	Description	Reference
Type	Select the type of the connected module.	Page 74, Section 7.1.2
Model Name	Select the model name of the connected module.	Page 74, Section 7.1.3
Points	Set the number of points assigned to each slot.	Page 74, Section 7.1.4
Start XY	Specify a start I/O number for each slot.	Page 74, Section 7.1.5
Switch Setting	Configure the switch setting of the built-in I/O or intelligent function modules.	Page 74, Section 7.1.6
Default Setting	Set the following: - Error Time Output Mode - PLC Operation Mode at HW Error - I/O Response Time	Page 75, Section 7.1.7

Setting "Start XY" enables modification on the start I/O numbers assigned to connected modules.

Ex. When "1000" is specified in "Start XY" to the slot where a 16-point module is connected, the assignment range of an input module is changed to X1000 to X100F.

For details, refer to the following.

📖 MELSEC-L CPU Module User's Manual (Function Explanation, Program Fundamentals)

Point

Set the type of the connected module in "Type". Setting a different type results in "SPUNIT LAY ERR". For the intelligent function module, the I/O points must also be the same in addition to the I/O assignment setting. (Page 30, Section 4.2.2)

Remark

When an intelligent module is connected, I/O assignment can be omitted by selecting connected modules from "Intelligent Function Module" in the Project window.

*1 The mouse operation example is provided below.

Annotations for the software screenshot:

- Menu bar: Ex. ☞ [Online] ⇨ [Write to PLC...]
Select [Online] on the menu bar, and then select [Write to PLC...].
- View selection area: Ex. ☞ Project window ⇨ [Parameter] ⇨ [PLC Parameter]
Select [Project] from the view selection area to open the Project window. In the Project window, expand [Parameter] and select [PLC Parameter].

Pages describing buffer memory areas and functions are organized as shown below.

The following illustration is for explanation purpose only, and should not be referred to as an actual documentation.

8.2.4 Manual Reset Function

Standard

These icons indicate modes that can be used.

The position of the stable condition in P control or PD control can be shifted manually using this function. By shifting the proportional band (PB), an offset (remaining deviation) is manually reset.

The offset is reset by determining and setting the amount to shift the value of the manipulated value (MV) in a stable condition from the reference value.

The reference value is 50% for standard control, and 0% for heating-cooling control.

Point

This function can be active only in P control and PD control. This function is inactive when integral time (I) is other than 0. CH3 Manual reset amount setting (UnIG724, UnIG740, UnIG756, UnIG772) is ignored even if it is set. (Note that a write data error (error code: 0003_h) occurs if it is outside the setting range.)

(1) Standard control

The set value (SV) is set where the manipulated value (MV) is 50%. Due to this, as long as the temperature process value (PV) and the set value (SV) is not in equilibrium at 50% of manipulated value, an offset (remaining deviation) generates.

When an offset generates, the proportional band (PB) can be manually shifted by the amount of the offset (remaining deviation).

Ex When using the manual reset function in the following conditions

- Control method: P control
- CH3 Manual reset amount setting (UnIG724, UnIG740, UnIG756, UnIG772): 300 (30%)

The Q64TCN shifts the manipulated value (MV) by which the temperature is stabilized at the set value (SV) from 50% to 80%.

137

Icon	Meaning
Common to all modes	
Common	This icon means that the buffer memory area or function can be used in both temperature control mode and temperature input mode.
Temperature control mode	This icon means that the buffer memory area or function for temperature control can be used in the standard control.
Standard	The buffer memory area and function can be used in the following control modes and channels: <ul style="list-style-type: none"> • CH1 to CH4 in the standard control • CH3 and CH4 in the mix control (normal mode) • CH3 and CH4 in the mix control (expanded mode)
Heating-cooling	This icon means that the buffer memory or function for temperature control can be used in the heating-cooling control.
Heating-cooling	The buffer memory area and function can be used in the following control modes and channels: <ul style="list-style-type: none"> • CH1 and CH2 in the heating-cooling control (normal mode) • CH1 to CH4 in the heating-cooling control (expanded mode) • CH1 in the mix control (normal mode) • CH1 and CH2 in the mix control (expanded mode)
Temperature input mode	
Temperature Input	This icon means that the buffer memory area or function can be used in the temperature input mode.

TERMS

Unless otherwise specified, this manual uses the following terms.

Term	Description
L60TCTT4	The abbreviation for the L60TCTT4 temperature control module
L60TCTT4BW	The abbreviation for the L60TCTT4BW temperature control module with the disconnection detection function
L60TCRT4	The abbreviation for the L60TCRT4 temperature control module
L60TCRT4BW	The abbreviation for the L60TCRT4BW temperature control module with the disconnection detection function
L60TC4	A generic term for the L60TCTT4, L60TCTT4BW, L60TCRT4, and L60TCRT4BW
PID constants	A generic term for the proportional band (P), integral time (I), and derivative time (D)
Temperature sensor	A generic term for thermocouples and platinum resistance thermometers
Control method	A generic term for two-position control, P control, PI control, PD control, and PID control
Temperature input mode	The mode to use the L60TC4 as a temperature input module
Temperature control mode	The mode to use the L60TC4 as a temperature control module
Control mode	A generic term for the standard control, heating-cooling control (normal mode), heating-cooling control (expanded mode), mix control (normal mode), and mix control (expanded mode) when the L60TC4 is used in the temperature control mode
Fixed value action	The operating status of when the set value (SV) is fixed
Full scale	A full input range. For example, when the selected input range is -200.0°C to 400.0°C, the full scale is 600.0.
Ramp action	The operating status of when the set value (SV) is constantly changed
Number of loops	The number of feedback control systems (closed-loop control systems) that can be configured using one module. Under the standard control, one loop consists of one input and one output. Under the heating-cooling control, one loop consists of one input and two outputs.
CPU module	Another term for the MELSEC-L series CPU module
Head module	The abbreviation for the LJ72GF15-T2 CC-Link IE Field Network head module
Display unit	A liquid crystal display to be attached to the CPU module
External input	The abbreviation for input from connectors for external devices
External output	The abbreviation for output to connectors for external devices
Programming tool	A generic term for GX Works2 and GX Developer
GX Works2	The product name of the software package for the MELSEC programmable controllers
GX Developer	
Buffer memory	The memory of an intelligent function module used to store data (such as setting values and monitored values) for communication with a CPU module

PACKING LIST

The following items are included in the package of this product. Before use, check that all the items are included.

L60TCTT4, L60TCRT4

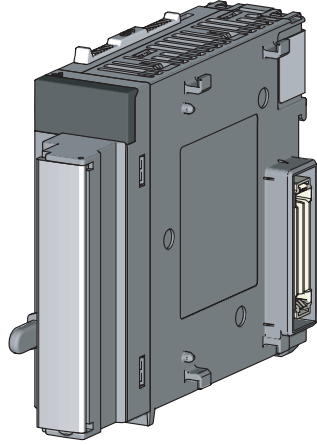

L60TCTT4, L60TCRT4

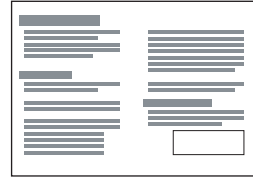

Before Using the Product

L60TCTT4BW, L60TCRT4BW

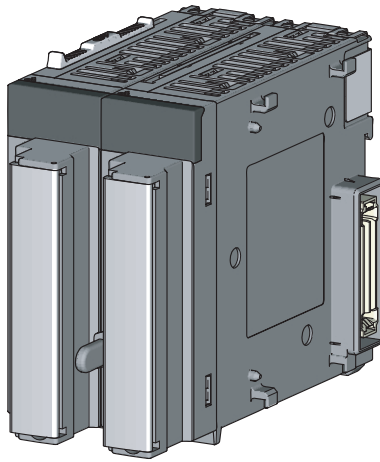

L60TCTT4BW, L60TCRT4BW



Before Using the Product

CHAPTER 1 WHAT CAN BE DONE WITH A TEMPERATURE CONTROL MODULE

1.1 Use

The L60TC4 performs PID operation to reach the target temperature based on input from an external temperature sensor. The module controls temperature by outputting the operation result to a heater or others in transistor output.

Point

The L60TCTT4BW and L60TCRT4BW are L60TCTT4 and L60TCRT4-based modules which possess an additional function to detect heater disconnection using input from external current sensors.

Ex. Standard control (heating)

The input from a temperature sensor is processed with PID operation, and the heater temperature is controlled.

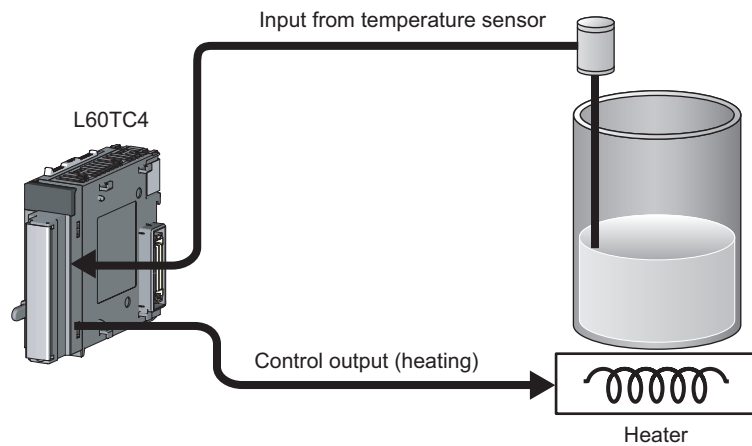

- Ex.** Heating-cooling control (heating and cooling)
 Heating and cooling are processed when the target temperature is lower than the ambient temperature or when the temperature of the target subject is easy to change.

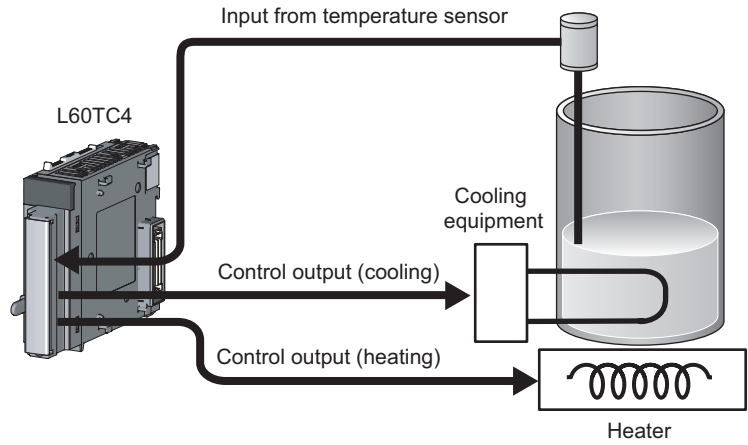

- Ex.** Temperature input (temperature input only)
 The L60TC4 can be used as a temperature input module also.

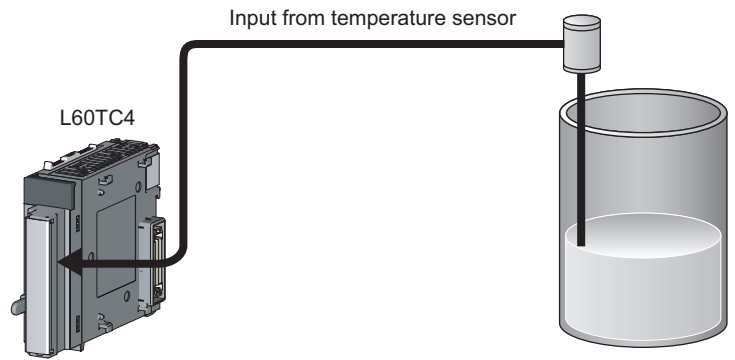

1.1 Use

1.2 Features

This section describes the L60TC4 features. For functions not described here, refer to the list of functions. (Page 39, Section 3.3)

(1) Optimum temperature adjustment control (PID control)

- The L60TC4 performs temperature adjustment control automatically when the user simply sets PID constants necessary for PID operation: proportional band (P), integral time (I), derivative time (D), and temperature set value (SV). No special instruction is necessary to perform PID control.
- Using the auto tuning function or self-tuning function enables the PID constants to be set automatically by the L60TC4. Complicated PID operational expressions to determine PID constants are not necessary.

(2) Combination of control mode

A control mode can be selected from the standard control (heating or cooling), heating-cooling control (heating and cooling), or mix control (combination of the standard control and heating-cooling control).

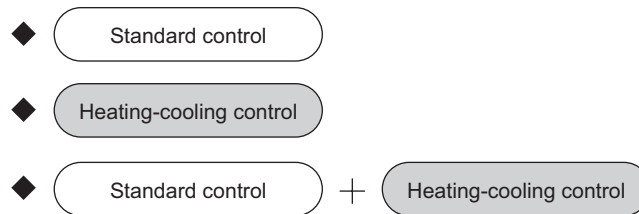

(3) Four loops on one module

The maximum of four loops of temperature adjustment control can be performed simultaneously. In addition, loop control can be performed using analog modules in the system; input from an A/D converter module or output to a D/A converter module can be processed.

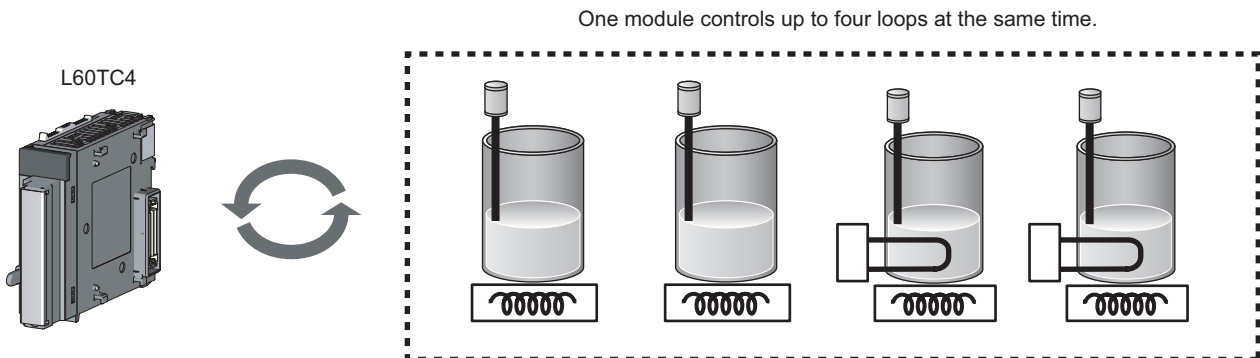

(4) Simultaneous temperature rise of multiple loops

Temperatures of multiple loops can be adjusted to simultaneously reach the set value of each; temperatures are controlled evenly without any partial heat exaggeration.

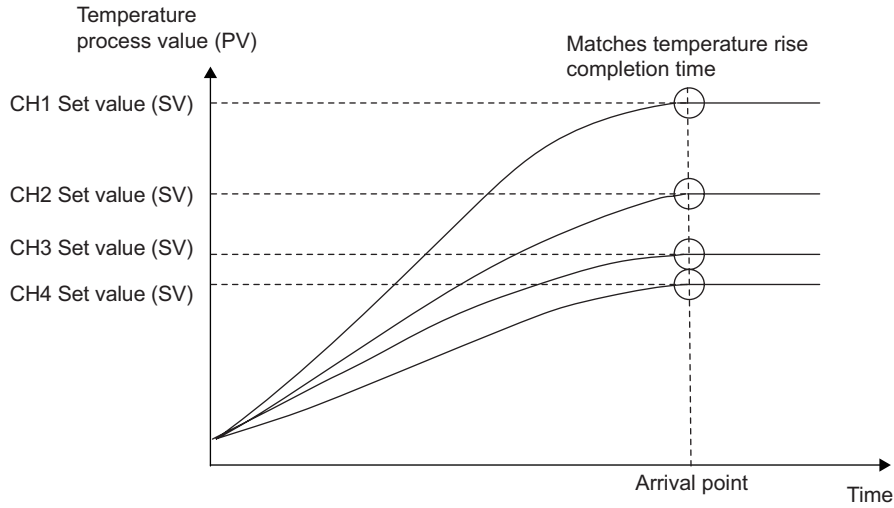

This function saves energy and cost.

Ex. Comparison of temperature rises on CH1 when using and not using the simultaneous temperature rise function

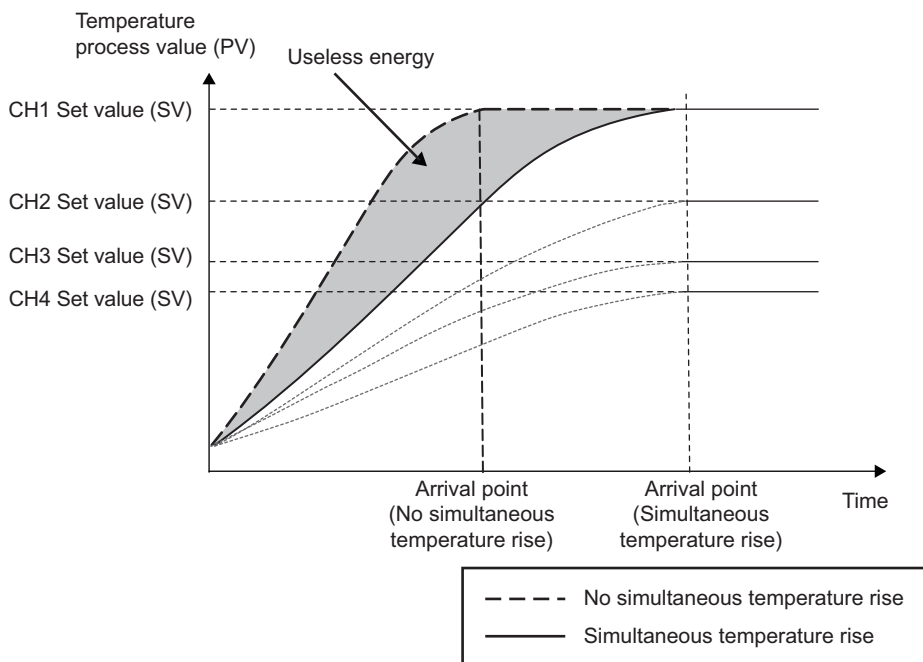

(5) Suppression of peak current

Current flows into a heater can be suppressed by controlling output so that each channel's output does not turn on at the same time as other channels.

This function saves energy and cost.

(6) RFB limiter function

The RFB (Reset feed back) limiter suppresses overshoot which is liable to occur at a startup or when a temperature process value (PV) is increased.

(7) Correction of temperature process value (PV)

The difference between the temperature process value (PV) and actual temperature can be corrected easily using the following functions.

- 1-point sensor compensation (standard) function: Corrects the difference by setting the rate of correction value to the full scale of the input range.
- 2-point sensor compensation function: Corrects the difference based on the inclination of the line on the two points set in advance.
- Primary delay digital filter setting: Smoothens extreme noise, and absorbs drastic change.

(8) Non-volatile memory for backing up set values

The set values in the buffer memory, such as the setting related to PID control, can be stored into a non-volatile memory for data backup. The values do not need to be reset after turning the power on from off or releasing the CPU module from its reset status.

Using the test function of the programming tool to write data directly to the buffer memory, the minimum sequence program required is "LD**" + "OUT Yn1".

(9) Detection of disconnection

Heater disconnection can be detected easily by the loop disconnection detection function.

The L60TCTT4BW and L60TCRT4BW can detect the disconnection of a heater accurately.

(10) Selectable sampling cycle

The module can be applied to wide range of systems since the sampling cycle can be selected from 250ms/4 channels or 500ms/4 channels.

(11) Use as a temperature input module

The L60TC4 can be used not only as a temperature control module, but also as a temperature input module. The mode can be switched easily by a setting.

In addition, The temperature input can be processed through the primary delay digital filter, or output as an alert.

 Page 116, Section 8.1)

(12) Easy setting by GX Works2

Sequence program can be reduced by configuring the default setting or auto refresh setting on the screen. Also, the setting status or operating status of the module can be checked easily.

1.3 The PID Control System

This section explains the PID control of the L60TC4.

(1) PID control system

The following figure shows a system of when performing the PID control.

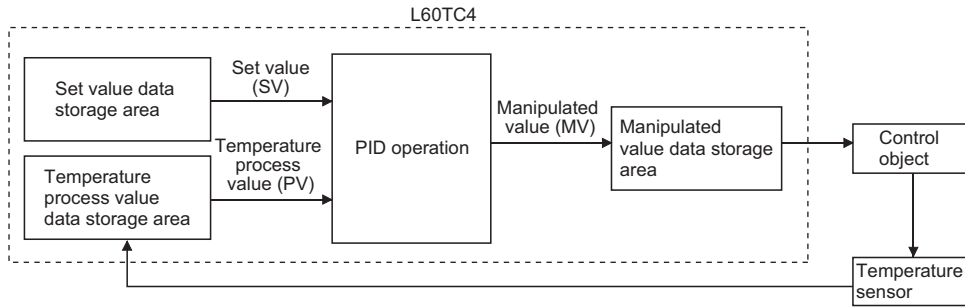

(2) PID control procedure

The PID control is performed in the following procedure.

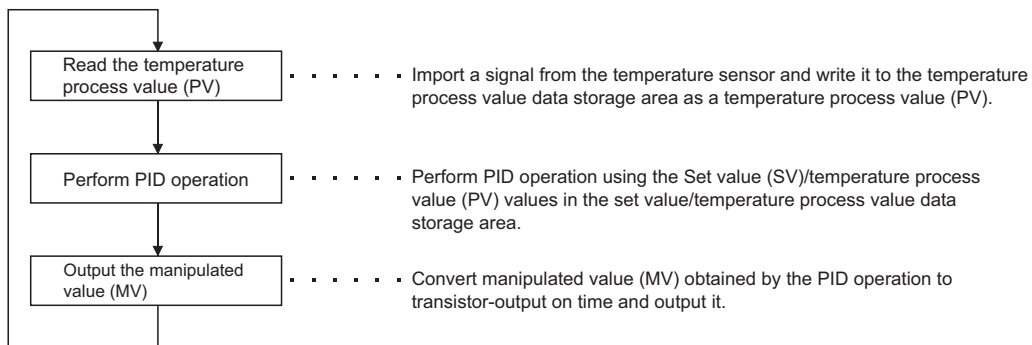

(3) PID control (simple two-degree-of-freedom)

The L60TC4 operates in "simple two-degree-of-freedom". In this form of PID control, parameters are simplified compared to the two-degree-of-freedom PID control.

In the simple two-degree-of-freedom, the module controls the target subject using not only PID constants but also the control response parameter. The parameter can be set to "fast", "normal", or "slow". This setting enables the form of "response to the change of the set value (SV)" to change maintaining "response to the disturbance" in a good condition. (☞ Page 153, Section 8.2.8)

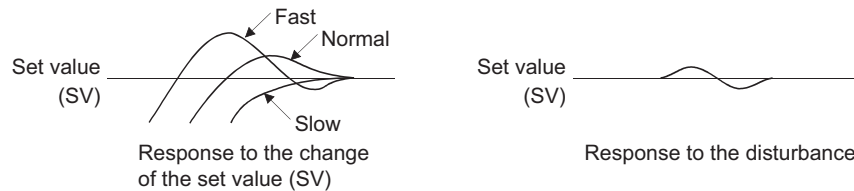

The following explains the difference between the one-degree-of-freedom PID control, two-degree-of-freedom PID control, and simple two-degree-of-freedom PID control.

(a) One-degree-of-freedom PID control and two-degree-of-freedom PID control

- General PID control is called one-degree-of freedom PID control. In the one-degree-of freedom PID control, when PID constants to improve "response to the change of the set value (SV)" are set, "response to the disturbance" degrades. Conversely, when PID constants to improve "response to the disturbance" are set, "response to the change of the set value (SV)" degrades.
- In the two-degree-of-freedom PID control, a manipulated value (MV) is determined considering the set value (SV) or variations. In this form of PID control, "response to the change of the set value (SV)" and "response to the disturbance" can be compatible with each other.

(b) Two-degree-of-freedom PID control and simple two-degree-of-freedom PID control

The following figure is a block diagram of the two-degree-of-freedom PID control.

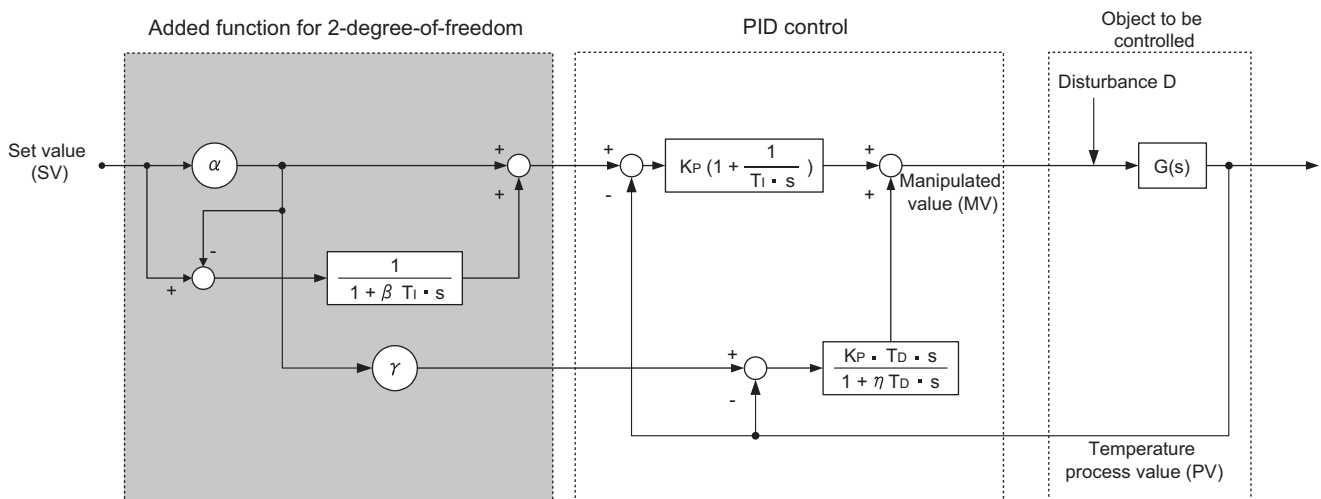

By setting α , β , and γ above properly, optimum control can be achieved.

Note that required parameter settings increase and PID constants can hardly be auto-set by the auto tuning function for complete two-degree-of-freedom PID control. Therefore, the L60TC4 operates in the simple two-degree-of-freedom PID control for which parameters are simplified.

1.4 About the PID Operation

The L60TC4 can perform PID control in process-value incomplete derivation.

1.4.1 Operation method and formula

The PID control in process-value incomplete derivation is an operation method which puts a primary delay filter on input from a derivative action and eliminate high-frequency noise component in order to perform a PID operation on the deviation (E).

(1) Algorithm of PID control in process-value incomplete derivation

The algorithm of PID control in process-value incomplete derivation is shown below.

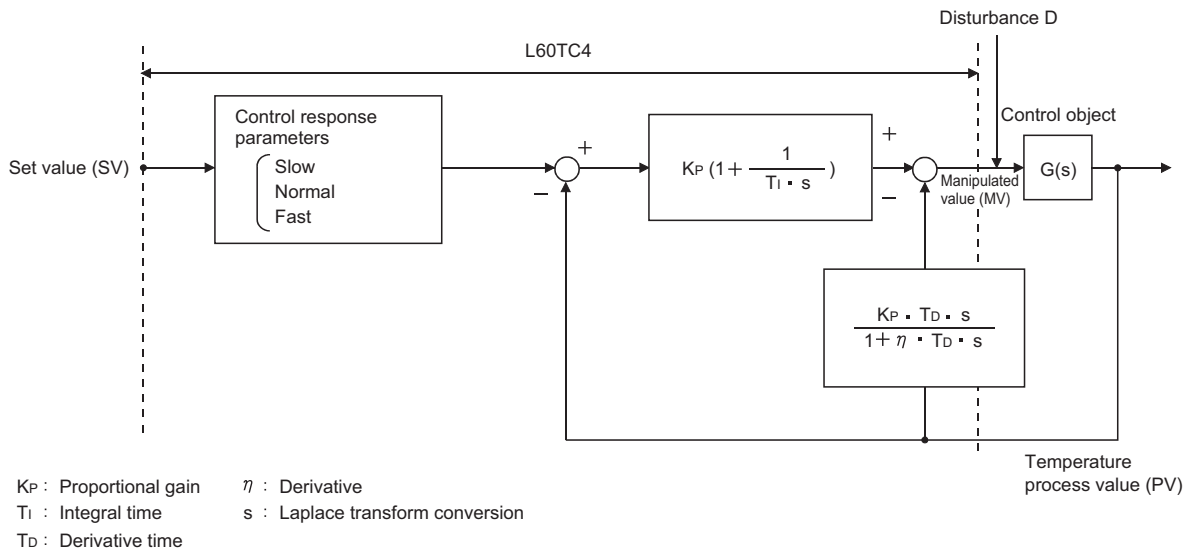

(2) Formula

The formula used for the L60TC4 is shown below.

$$MV_n = MV_{n-1} + \frac{T_D}{\tau + \eta \cdot T_D} \left\{ (PV_{n-1} - PV_n) - \frac{\tau}{T_D} \cdot MV_{n-1} \right\}$$

- τ : Sampling period
- MV : Incomplete derivative output
- PV : Temperature process value (PV)
- T_D : Derivative time
- η : Derivative

Remark
 The PID control in process-value derivation is an operation method which uses the process value (PV) for the derivation section in order to perform a PID operation. Not using deviation for the derivation section, drastic output change due to a derivative action is reduced when deviation varies along with the setting value change.

1.4 About the PID Operation
 1.4.1 Operation method and formula

1.4.2 The L60TC4 actions

The L60TC4 performs PID operations in forward actions and reverse actions.

(1) Forward action

In a forward action, the manipulated value (MV) is increased when the temperature process value (PV) increases from the set value (SV).

A forward action is used for cooling control.

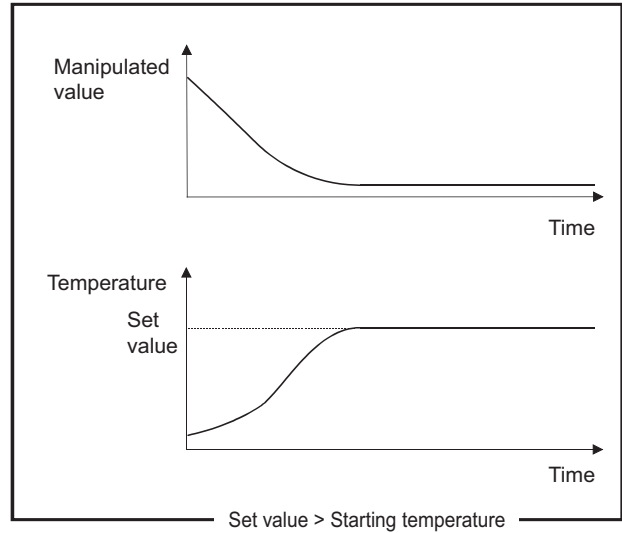
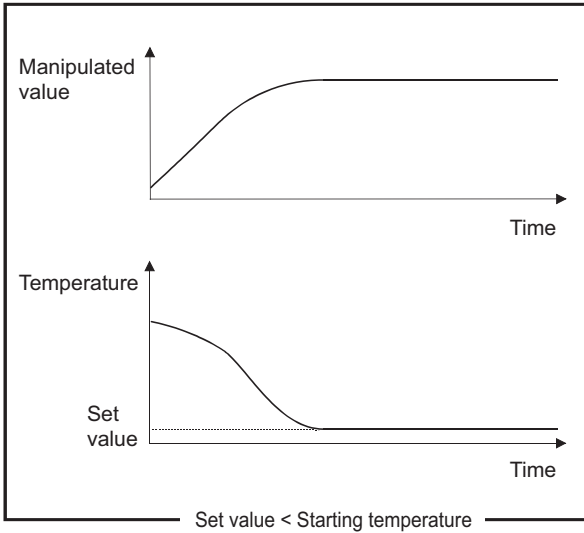

(2) Reverse action

In a reverse action, the manipulated value is increased when the temperature process value (PV) decreases from the set value (SV).

A reverse action is used for heating control.

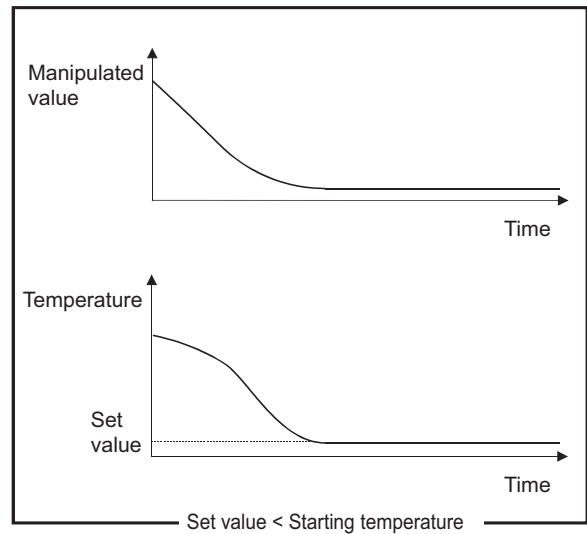
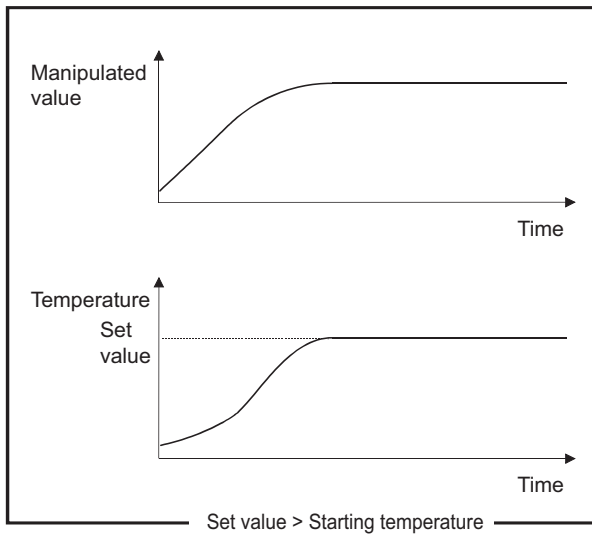

1.4.3 Proportional action (P-action)

A proportional action is an action to obtain the manipulated value (MV) proportional to the deviation (difference between the set value (SV) and the process value (PV)).

(1) Proportional gain

In a proportional action, the relationship between changes in the deviation (E) and the manipulated value can be expressed in the following formula:

$$MV = K_p \cdot E$$

where K_p is a proportional constant and is called proportional gain. The manipulated value (MV) varies in the range from -5.0% to 105.0%.

The following table describes the difference of actions depending on the value of K_p , proportional gain.

Condition	Proportional action
K_p is a small value	The control action slows down.
K_p is a large value	The control action speeds up, though the temperature process value (PV) tends to fluctuate around the set value.

A proportional action is as shown below for step responses where the deviation (E) is a fixed value.

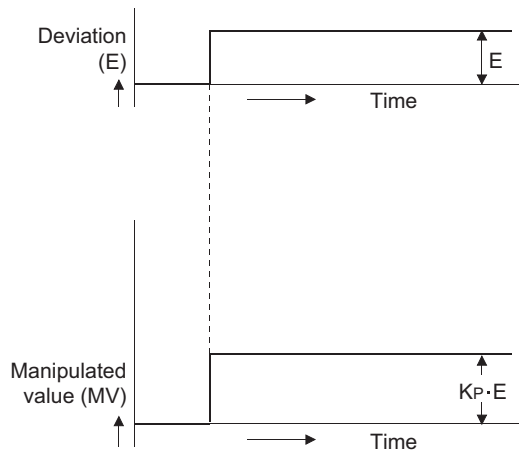

(2) Offset

The certain amount of difference generates between the temperature process value (PV) and the set value (SV) is called an offset (remaining deviation).

In an proportional action, an offset (remaining deviation) generates.

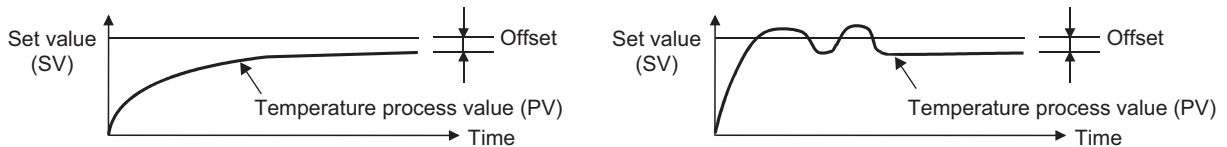

1.4.4 Integral action (I-action)

An integral action is an action which continuously changes the manipulated value (MV) to eliminate the deviation (E) when there is any.

The offset caused by a proportional action can be eliminated.

In an integral action, the time from a deviation occurrence until when the manipulated value (MV) of the integral action becomes equals to that of the proportional action is called integral time, and is indicated as T_i .

The following table describes the difference of actions depending on the value of T_i , integral time.

Condition	Integral action
T_i is a small value	The integral effect gets large, and time to eliminate the offset gets short. Though, the temperature process value (PV) tends to fluctuate around the set value.
T_i is a large value	The integral effect gets small, and time to eliminate the offset gets long.

The following figure shows an integral action of step responses where the deviation (E) is a fixed value.

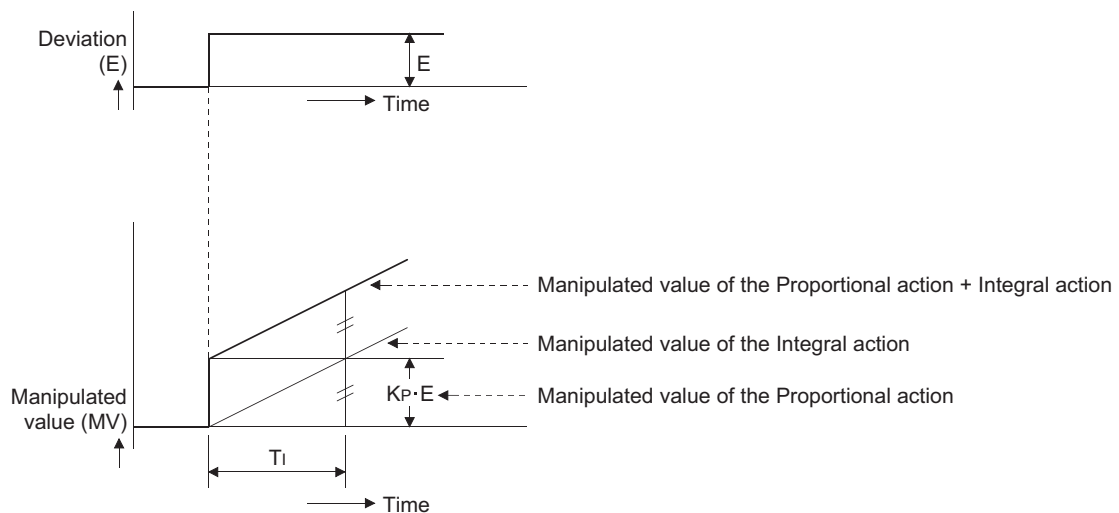

An integral action is used as a PI action in combination with a proportional action, or PID action in combination with a proportional and derivative actions.

An integral action cannot be used by itself.

1.4.5 Derivative action (D-action)

A derivative action adds the manipulated value (MV) proportional to the rate of change to eliminate the deviation (E) when it occurs.

A derivative action can prevent the control target from changing significantly due to disturbance.

In an integral action, the time from a deviation occurrence until when the manipulated value (MV) of the derivative action becomes equals to that of the proportional action is called derivative time, and is indicated as T_D .

The following table describes the difference of actions depending on the value of T_D , derivative time.

Condition	Derivative action
T_D is a small value	The derivative effect gets small.
T_D is a large value	The derivative effect gets large. Though, the temperature process value (PV) tends to fluctuate around the set value in short cycles.

The following figure shows a derivative action of step responses where the deviation (E) is a fixed value.

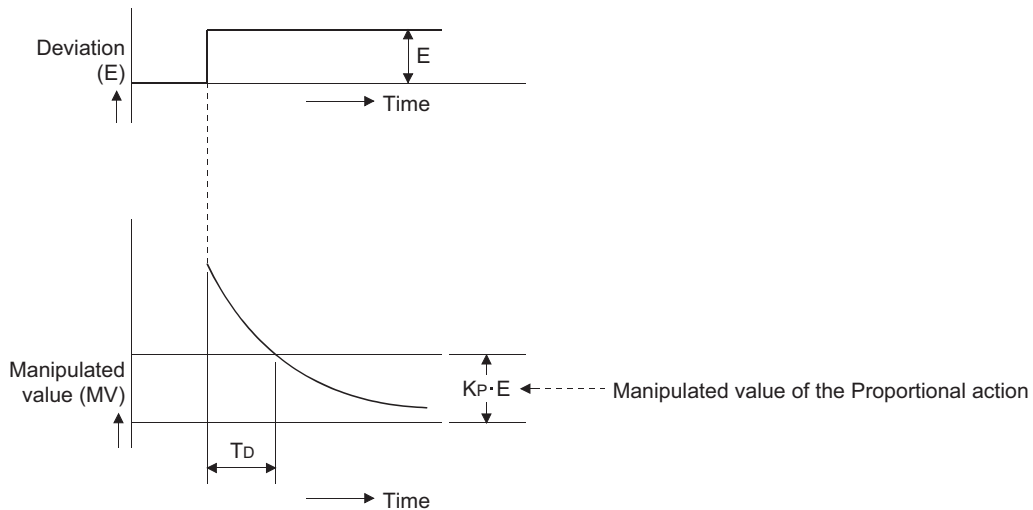

A derivative action is used as a PD action in combination with a proportional action, or PID action in combination with a proportional and integral actions.

A derivative action cannot be used by itself.

1.4.6 PID action

A PID action performs control using the manipulated value (MV) calculated by merging the proportional action, integral action, and derivative action.

The following figure shows a PID action of step responses where the deviation (E) is a fixed value.

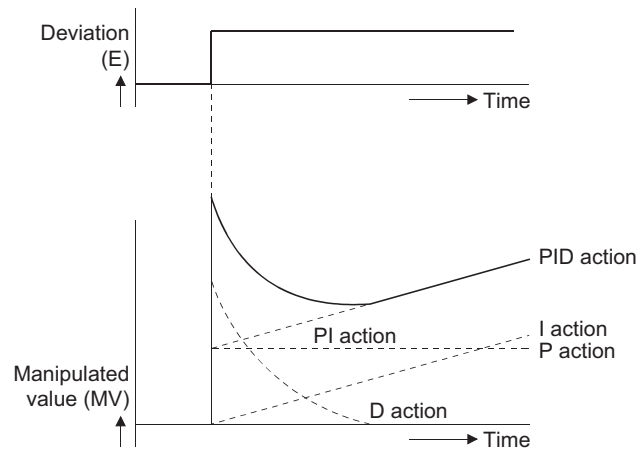

CHAPTER 2 PART NAMES

The following table shows part names of the L60TC4.

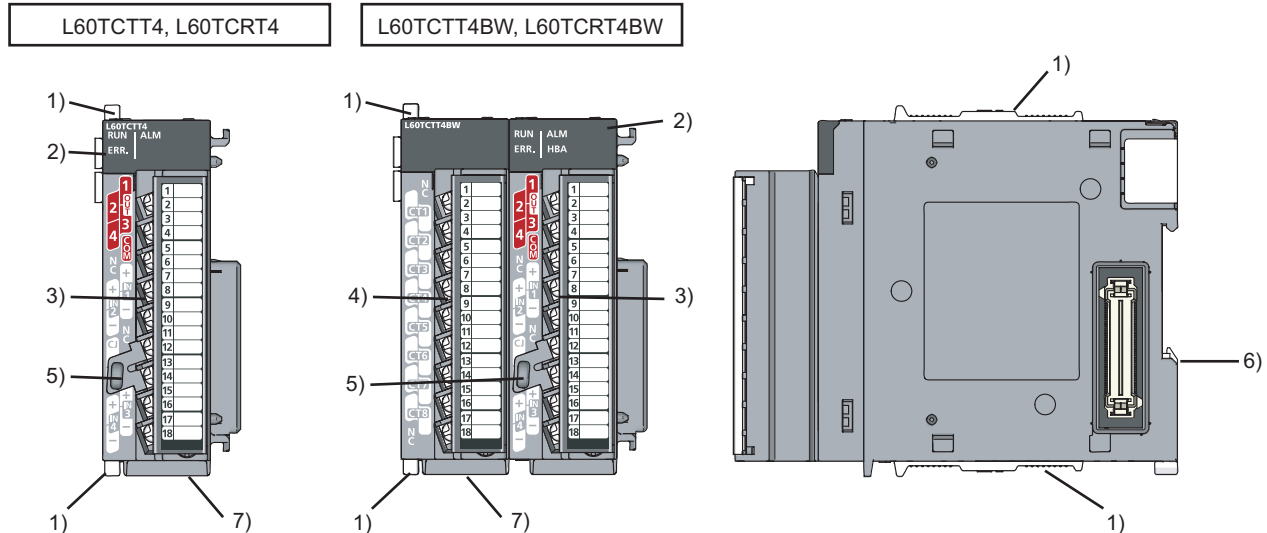

Number	Name	Description	
1)	Module joint levers	Levers for connecting modules	
2)	RUN LED	Indicates the operating status of the L60TC4.	
		ON	Operating normally
	OFF	<ul style="list-style-type: none"> The power is not supplied. The watchdog timer error has occurred. CPU stop error has occurred when all channels are set to "CLEAR" on Switch Setting. A value out of the setting range was set on Switch Setting 2 to 5. 	
	ERR. LED	Indicates the error status of the L60TC4.	
		ON	Hardware fault (Including no connection of a cold junction temperature compensation resistor)
		Flicker	Error occurring (☞ Page 334, Appendix 2 (1))
	OFF	Operating normally	
	ALM LED	Indicates the alert status of the L60TC4.	
		ON	Alert is occurring.
		Flicker	<ul style="list-style-type: none"> Temperature process value (PV) came out of temperature measurement range. Loop disconnection was detected. Temperature sensor is not connected.
OFF	Alert is not occurring.		
HBA LED (the L60TCTT4BW and L60TCRT4BW only)	Indicates the heater disconnection detection status of the L60TCTT4BW and L60TCRT4BW.		
	ON	Heater disconnection was detected.	
	OFF	Heater disconnection is not detected.	

Number	Name	Description
3)	Terminal block for I/O	Used for temperature sensor input and transistor output. ( Page 85, Section 6.2)
4)	Terminal block for CT	Used for current sensor (CT) input.
5)	Cold junction temperature compensation resistor (the L60TCTT4 and L60TCTT4BW only)	Used when cold junction temperature compensation is executed for the L60TCTT4 and L60TCTT4BW.
6)	DIN rail hook	A hook used to mount the module to a DIN rail.
7)	Serial number plate	Displays the serial number printed on the rating plate. For the L60TCTT4BW, L60TCRT4BW, the serial number is displayed on the terminal block for CT.

CHAPTER 3 SPECIFICATIONS

This chapter describes general specifications, performance specifications, the function list, the I/O signal list, and the buffer memory list.

3.1 General Specifications

For the general specifications of the L60TC4, refer to the following manual.

 "Safety Guidelines", the manual supplied with a CPU module or head module

3.2 Performance Specifications

The following table lists the performance specifications of the L60TC4.

Item		Specifications				
		L60TCTT4	L60TCRT4	L60TCTT4BW	L60TCRT4BW	
Control output		Transistor output				
Number of temperature input points		4 channels/module				
Type of usable temperature sensors, the temperature measurement range, the resolution, and the effect from wiring resistance of 1Ω		 Page 36, Section 3.2.2				
Accuracy*1	Indication accuracy	Ambient temperature: 25±5°C	Full scale × (±0.3%)			
		Ambient temperature: 0 to 55°C	Full scale × (±0.7%)			
	Cold junction temperature compensation accuracy: (ambient temperature: 0 to 55°C)	Temperature process value (PV): -100°C or more	Within ±1.0°C	—	Within ±1.0°C	—
		Temperature process value (PV): -150 to -100°C	Within ±2.0°C		Within ±2.0°C	
Temperature process value (PV): -200 to -150°C		Within ±3.0°C	Within ±3.0°C			
Sampling cycle		250ms/4 channels 500ms/4 channels				
Control output cycle		0.5 to 100.0s				
Input impedance		1MΩ				
Input filter		0 to 100s (0: Input filter OFF)				
Sensor correction value setting		-50.00 to 50.00%				
Operation at sensor input disconnection		Upscale processing				
Temperature control method		PID ON/OFF pulse or two-position control				
PID constants range		PID constants setting	Can be set by auto tuning.			
		Proportional band (P)	0.0 to 1000.0% (0: Two-position control)			
		Integral time (I)	0 to 3600s (set 0 for P control and PD control.)			
		Derivative time (D)	0 to 3600s (set 0 for P control and PI control.)			
Set value (SV) setting range		Within the temperature range set in the thermocouple/platinum resistance thermometer to be used				
Dead band setting range		0.1 to 10.0%				
Transistor output		Output signal	ON/OFF pulse			
		Rated load voltage	10 to 30VDC			
		Max. load current	0.1A/point, 0.4A/common			
		Max. inrush current	0.4A 10ms			
		Leakage current at OFF	0.1mA or less			
		Max. voltage drop at ON	1.0VDC (TYP) at 0.1A 2.5VDC (MAX) at 0.1A			
		Response time	OFF→ON: 2ms or less, ON→OFF: 2ms or less			
Number of accesses to non-volatile memory		Max. 10 ¹² times				
Insulation method		Between input terminal and programmable controller power supply: Transformer insulation Between input channels: Transformer insulation				

Item	Specifications			
	L60TCTT4	L60TCRT4	L60TCTT4BW	L60TCRT4BW
Dielectric withstand voltage	Between input terminal and programmable controller power supply: 500VAC for 1 minute Between input channels: 500VAC for 1 minute			
Insulation resistance	Between input terminal and programmable controller power supply: 500VDC 20MΩ or more Between input channels: 500VDC 20MΩ or more			
Heater disconnection detection specifications	Current sensor	—		 Page 82, Section 5.2 (4)
	Input accuracy	—		Full scale × (±1.0%)
	Number of alert delay	—		3 to 255
Number of occupied I/O points	16 points (I/O assignment: 16 intelligent points)			
Number of occupied module	1		2	
Connected terminal	18-point terminal block		Two 18-point terminal blocks	
Applicable wire size	0.3mm ² to 0.75mm ²			
Applicable solderless terminal	R1.25-3 (Solderless terminal with sleeve is unavailable.)			
Internal current consumption	0.30A	0.31A	0.33A	0.35A
Weight	0.18kg		0.33kg	
Outline dimensions	28.5(W)mm × 90(H)mm × 117(D)mm		57.0(W)mm × 90(H)mm × 117(D)mm	

*1 Calculate the accuracy in the following method (only when it is not affected by noise).
Accuracy (°C) = full scale × indication accuracy + cold junction temperature compensation accuracy

Ex. Accuracy at the input range of 38 (-200.0 to 400.0°C), the operating ambient temperature of 35°C, and the temperature process value (PV) of 300°C

$$\begin{aligned} & (\text{Full scale}) \times (\text{indication accuracy}) + \text{cold junction temperature compensation accuracy} \\ & = (400.0^\circ\text{C} - (-200.0^\circ\text{C})) \times (\pm 0.007) + (\pm 1.0^\circ\text{C}) \\ & = \pm 5.2^\circ\text{C} \end{aligned}$$

For the noise immunity, dielectric withstand voltage, insulation resistance and others of the programmable controller system which uses the L60TC4, refer to the following manual.

 MELSEC-L CPU Module User's Manual (Hardware Design, Maintenance and Inspection)

 MELSEC-L CC-Link IE Field Network Head Module User's Manual

3.2.1 Number of parameters to be set

The total number of the parameters of the initial setting and of the auto refresh setting of the L60TC4 must be within the number of parameters which can be set in the CPU module including the number of other intelligent function module parameters.

For the maximum number of parameters which can be set in a CPU module (maximum number of set parameter), refer to the following manual.

 MELSEC-L CPU Module User's Manual (Hardware Design, Maintenance and Inspection)

 MELSEC-L CC-Link IE Field Network Head Module User's Manual

(1) Number of parameters of the L60TC4

The following table lists the number of parameters that can be set for one L60TC4.

Target module	Initial setting	Auto refresh setting
L60TCTT4	43	103 (Max.)
L60TCRT4		
L60TCTT4BW	43	115 (Max.)
L60TCRT4BW		

(2) Checking method

The current number and maximum number of the parameters set in the intelligent function module can be checked by the following operation.

-  Project window ⇨ [Intelligent Function Module] ⇨ Right-click
- ⇨ [Intelligent Function Module Parameter List...]

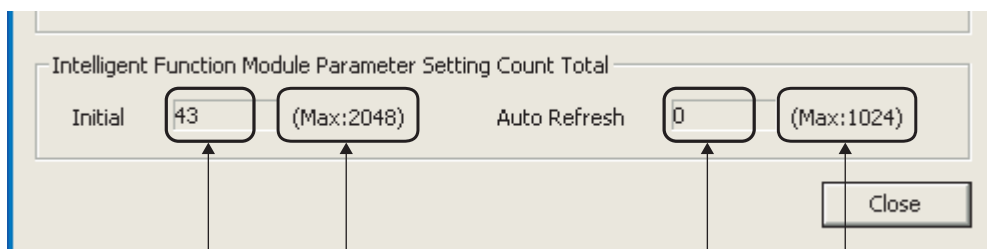
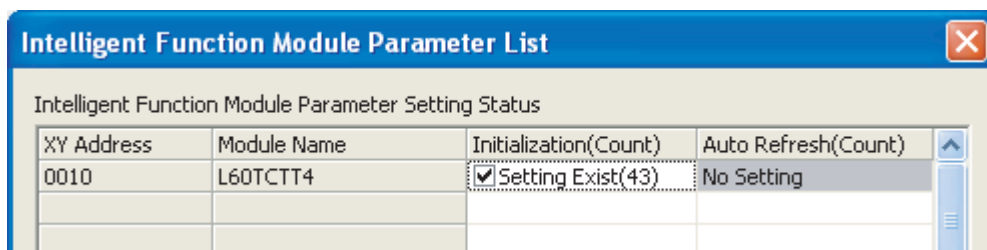

1)

2)

3)

4)

No.	Description
1)	Total number of the parameters of the initial setting that is checked on the window
2)	Maximum number of parameters of the initial setting

No.	Description
3)	Total number of the parameters of the auto refresh setting that is checked on the window
4)	Maximum number of parameters of the auto refresh setting

3.2.2 Type of usable temperature sensors, temperature measurement range, resolution, and effect from wiring resistance of 1 ohm

This section describes the types of temperature sensors that can be used with the L60TC4, the temperature measurement range, the resolution, and the effect from wiring resistance of 1Ω.

Set the used temperature sensor in the following buffer memory area.

- CH□ Input range (Un\G32, Un\G64, Un\G96, Un\G128) (Page 345, Appendix 2 (12))

(1) L60TCTT4, L60TCTT4BW

The following table lists the types of thermocouples that can be used with the L60TCTT4 and L60TCTT4BW, the temperature measurement range, the resolution, and the effect from wiring resistance of 1Ω.

Thermocouple type	°C			°F		
	Temperature measurement range	Resolution	Effect from wiring resistance of 1Ω (°C/Ω)*1	Temperature measurement range	Resolution	Effect from wiring resistance of 1Ω (°F/Ω)*1
R	0 to 1700	1	0.030	0 to 3000	1	0.054
K	0 to 500 0 to 800 0 to 1300	1	0.005	0 to 1000 0 to 2400	1	0.008
	-200.0 to 1300.0 -200.0 to 400.0 0.0 to 400.0 0.0 to 500.0 0.0 to 800.0	0.1		0.0 to 1000.0	0.1	
J	0 to 500 0 to 800 0 to 1200	1	0.003	0 to 1000 0 to 1600 0 to 2100	1	0.006
	-200.0 to 1000.0 0.0 to 400.0 0.0 to 500.0 0.0 to 800.0	0.1		0.0 to 1000.0	0.1	
T	-200 to 400 -200 to 200 0 to 200 0 to 400	1	0.004	0 to 700 -300 to 400	1	0.008
	-200.0 to 400.0 0.0 to 400.0	0.1		0.0 to 700.0	0.1	
S	0 to 1700	1	0.030	0 to 3000	1	0.054
B	0 to 1800 ^{*2}	1	0.038	0 to 3000 ^{*2}	1	0.068
E	0 to 400 0 to 1000	1	0.003	0 to 1800	1	0.005
	-200.0 to 1000.0 0.0 to 700.0	0.1		—	—	—
N	0 to 1300	1	0.006	0 to 2300	1	0.011
	0.0 to 1000.0	0.1		—	—	—
U	0 to 400 -200 to 200	1	0.004	0 to 700 -300 to 400	1	0.009
	0.0 to 600.0	0.1		—	—	—

Thermocouple type	°C			°F		
	Temperature measurement range	Resolution	Effect from wiring resistance of 1Ω (°C/Ω)*1	Temperature measurement range	Resolution	Effect from wiring resistance of 1Ω (°F/Ω)*1
L	0 to 400 0 to 900	1	0.003	0 to 800 0 to 1600	1	0.006
	0.0 to 400.0 0.0 to 900.0	0.1		—	—	—
PLII	0 to 1200	1	0.005	0 to 2300	1	0.010
W5Re/W26Re	0 to 2300	1	0.017	0 to 3000	1	0.021

*1 Means temperature error per Ω of wiring resistance of the thermocouple. The temperature error can be corrected by the sensor compensation function. (Page 223, Section 8.3.2)

*2 While temperature can be measured within less than 400°C/800°F, the accuracy cannot be guaranteed.

(2) L60TCRT4, L60TCRT4BW

The following table lists the types of platinum resistance thermometer that can be used with the L60TCRT4 and L60TCRT4BW and temperature measurement range.

Platinum resistance thermometer type	°C		°F	
	Temperature measurement range	Resolution	Temperature measurement range	Resolution
Pt100	-200.0 to 850.0	0.1	-300 to 1100	1
	-200.0 to 600.0		-300.0 to 300.0	0.1
	-200.0 to 200.0			0.1
JPt100	-200.0 to 640.0	0.1	-300 to 900	1
	-200.0 to 500.0		-300.0 to 300.0	0.1
	-200.0 to 200.0			0.1

3.2.3 Sampling cycle and control output cycle

This section describes the sampling cycle and control output cycle of the L60TC4.

(1) Sampling cycle

The L60TC4 performs PID operations in the order of CH1, CH2, CH3, CH4, CH1, CH2

The time from when PID operation is started on the current channel (CHn) until PID operation is restarted on the current channel (CHn) is called a sampling cycle. Select 250ms or 500ms as a sampling cycle. (☞ Page 108, Section 7.2 (1))

The number of used channels and the settings of unused channels do not affect the sampling cycle.

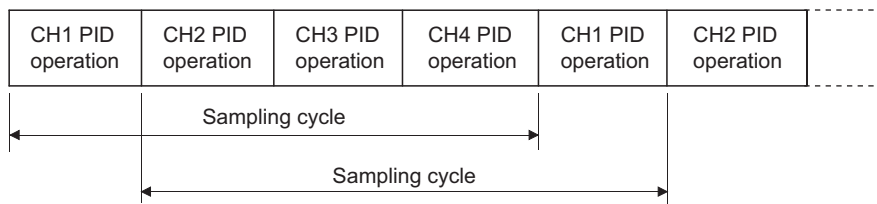

(2) Control output cycle

The control output cycle is the ON/OFF cycle of transistor output.

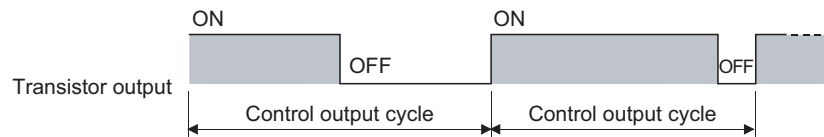

The manipulated value (MV) represents the ON time of the control output cycle in percentage. (☞ Page 339, Appendix 2 (5))

Set the control output cycle in the following buffer memory area in the range of 1 to 100s.

- CH□ Control output cycle setting (Un\G47, Un\G79, Un\G111, Un\G143) (☞ Page 364, Appendix 2 (23))

In the heating-cooling control, the following buffer memory areas are used for the manipulated value (MV) and control output cycle.

Data type	Buffer memory area name	Buffer memory address				Reference
		CH1	CH2	CH3	CH4	
Manipulated value (MV)	Manipulated value for heating (MVh)	Un\G13	Un\G14	Un\G15	Un\G16	Page 339, Appendix 2 (5)
	Manipulated value for cooling (MVc)	Un\G704	Un\G705	Un\G706	Un\G707	
Control output cycle	Heating control output cycle setting	Un\G47	Un\G79	Un\G111	Un\G143	Page 364, Appendix 2 (23)
	Cooling control output cycle setting	Un\G722	Un\G738	Un\G754	Un\G770	

3.3 Function List

This section lists the L60TC4 functions.

(1) When the L60TC4 is used as a temperature input module

Item	Description	Reference
Conversion enable/disable function	Whether to enable or disable the temperature conversion can be set for each channel.	Page 117, Section 8.1.1
Temperature conversion method	The measured temperature by each sampling cycle is stored in the buffer memory. The temperature process values (PV) can be smoothed and sudden changes can be controlled by using the primary delay filter.	Page 117, Section 8.1.2
Alert output function	An alert is output if the temperature process value (PV) meets the condition set in advance. The alert has process alarm and rate alarm.	Page 120, Section 8.1.3

(2) When the L60TC4 is used as a temperature control module

○: Enable, ×: Disable

Item	Description	Enable or disable		Reference
		Standard control	Heating-cooling control	
Control mode selection function	The control mode can be selected from the following modes. <ul style="list-style-type: none"> • Standard control • Heating-cooling control (normal mode) • Heating-cooling control (expanded mode) • Mix control (normal mode) • Mix control (expanded mode) 	○	○	Page 126, Section 8.2.1
Output setting at CPU stop error function	Whether to clear or hold the transistor output status when a CPU stop error occurs or when a CPU module is turned from RUN to STOP can be selected.	○	○	Page 128, Section 8.2.2
Control method	The following control methods can be used with the settings of proportional band (P), integral time (I), and derivative time (D). <ul style="list-style-type: none"> • Two-position control • P control • PI control • PD control • PID control 	○	○	Page 129, Section 8.2.3
Manual reset function	The stable status position in the P control or PD control can be moved manually.	○	○	Page 137, Section 8.2.4
Manual control	The manipulated value (MV) can be set manually by users without automatic calculation by the PID control.	○	○	Page 139, Section 8.2.5
Control output cycle unit selection function	The unit for control output cycle can be selected from 1s or 0.1s and switched between them. Setting the control output cycle to 0.1s allows a more detailed control to be performed.	○	○	Page 140, Section 8.2.6
Auto tuning function	The L60TC4 sets the optimal PID constants automatically.	○	○	Page 141, Section 8.2.7
Simple two-degree-of-freedom	In addition to the PID control, the response speed can be selected from three levels. The simple two-degree-of-freedom PID control can be realized.	○	○	Page 153, Section 8.2.8

Item	Description	Enable or disable		Reference
		Standard control	Heating-cooling control	
Derivative action selection function	Dynamic performance can be improved by selecting the suitable derivative action for the fixed value action and the ramp action.	○	○	Page 154, Section 8.2.9
Setting change rate limiter setting function	Change rate setting of the set value (SV) per set time unit when this value is changed. The batch setting or individual setting can be selected for the temperature rise and drop.	○	○	Page 155, Section 8.2.10
Alert function	The modules goes to the alert status when the temperature process value (PV) or deviation (E) meets the condition set in advance.	○	○	Page 157, Section 8.2.11
RFB limiter function	When the deviation (E) continues for a long time, the PID operation result (manipulated value (MV)) by the integral action can be prevented from exceeding the effective range of the manipulated value (MV).	○	○	Page 171, Section 8.2.12
Input/output (with another analog module) function	Data can be input and output using another analog module (A/D conversion module or D/A converter module) on the system.	○	○	Page 172, Section 8.2.13
ON delay output function	Setting with considering delay time (response/scan time delay) of actual transistor output is possible.	○	○	Page 174, Section 8.2.14
Self-tuning function	The L60TC4 monitors the control status constantly. If the control system oscillates due to a status soon after the control starts, a change of the set value (SV), and property fluctuation of a controlled object, PID constants are changed automatically.	○	×	Page 175, Section 8.2.15
Peak current suppression function	Changing automatically the upper limit output limiter value of each channel and dividing the timing of transistor output can suppress the peak current.	○	×	Page 185, Section 8.2.16
Simultaneous temperature rise function	This function allows several loops to reach the set value (SV) at the same time.	○	×	Page 190, Section 8.2.17
Forward action/reverse action selection function	Whether to perform PID operations in the forward action or reverse action can be selected.	○	×	Page 203, Section 8.2.18
Loop disconnection detection function	Errors in the control system (control loop) can be detected.	○	×	Page 204, Section 8.2.19
Proportional band setting function	The proportional band (P) can be individually set for heating or cooling.	×	○	Page 206, Section 8.2.20
Cooling method setting function	When the auto tuning is executed, an auto tuning formula is automatically selected according to the selected cooling method and the operation starts.	×	○	Page 207, Section 8.2.21
Overlap/dead band function	By changing the temperature where the cooling transistor output is started, whether control stability is prioritized or energy saving is prioritized can be selected.	×	○	Page 209, Section 8.2.22
Temperature conversion function (using unused channels)	In heating-cooling control (normal mode) and mix control (normal mode), only temperature measurement is allowed by using unused temperature input terminals.	×	○	Page 212, Section 8.2.23
Heater disconnection detection function	The current which flows in the heater main circuit can be measured and disconnections can be detected.	○	○	Page 215, Section 8.2.24
Output off-time current error detection function	An error of when the transistor output is off can be detected.	○	○	Page 220, Section 8.2.25

(3) Common functions

Item	Description	Reference
Temperature process value (PV) scaling function	The temperature process value (PV) can be converted to the set width and this value can be imported into the buffer memory.	Page 221, Section 8.3.1
Sensor compensation function	<p>If a difference between a temperature process value (PV) and an actual temperature occurs due to the measurement status, the error can be corrected. Select a correction method from the following two types.</p> <ul style="list-style-type: none"> • 1-point sensor compensation (standard) function: The percentage of the full scale of the set input range can be corrected as an error corrected value. • 2-point sensor compensation function: An error is corrected by setting any two points (corrected offset value and corrected gain value). 	Page 223, Section 8.3.2
Auto-setting at the input range change	When the input range is changed, the related buffer memory data is changed automatically so that errors outside the setting range does not occur.	Page 234, Section 8.3.3
Buffer memory data backup function	The buffer memory data can be stored and backed up in the non-volatile memory.	Page 235, Section 8.3.4
Error history function	Up to 16 errors and alarms that occur on the L60TC4 are stored in the buffer memory as history.	Page 237, Section 8.3.5
Module error history collection function	Error contents can be notified to the CPU module when errors and alarms occur on the L60TC4. Error information is held in the memory inside of the CPU module as module error history.	Page 239, Section 8.3.6
Error clear function	When an error occurs, the error can be cleared on the system monitor.	Page 240, Section 8.3.7

3.4 I/O Signal List

This section describes the assignment and applications of the L60TC4 input signals.

(1) Input signal list

Input signal (signal direction: CPU module ← L60TC4)				
Device No.	Temperature input mode	Standard control	Heating-cooling control	Mix control
Xn0	Module READY flag	Module READY flag	Module READY flag	Module READY flag
Xn1	Setting/operation mode status	Setting/operation mode status	Setting/operation mode status	Setting/operation mode status
Xn2	Error occurrence flag	Error occurrence flag	Error occurrence flag	Error occurrence flag
Xn3	Hardware error flag	Hardware error flag	Hardware error flag	Hardware error flag
Xn4	N/A	CH1 Auto tuning status	CH1 Auto tuning status	CH1 Auto tuning status
Xn5	N/A	CH2 Auto tuning status	CH2 Auto tuning status	CH2 Auto tuning status ^{*2}
Xn6	N/A	CH3 Auto tuning status	CH3 Auto tuning status ^{*1}	CH3 Auto tuning status
Xn7	N/A	CH4 Auto tuning status	CH4 Auto tuning status ^{*1}	CH4 Auto tuning status
Xn8	Back-up of the set value completion flag	Back-up of the set value completion flag	Back-up of the set value completion flag	Back-up of the set value completion flag
Xn9	Default value write completion flag	Default value write completion flag	Default value write completion flag	Default value write completion flag
XnA	Back-up of the set value fail flag	Back-up of the set value fail flag	Back-up of the set value fail flag	Back-up of the set value fail flag
XnB	Setting change completion flag	Setting change completion flag	Setting change completion flag	Setting change completion flag
XnC	CH1 Alert occurrence flag	CH1 Alert occurrence flag	CH1 Alert occurrence flag	CH1 Alert occurrence flag
XnD	CH2 Alert occurrence flag	CH2 Alert occurrence flag	CH2 Alert occurrence flag	CH2 Alert occurrence flag
XnE	CH3 Alert occurrence flag	CH3 Alert occurrence flag	CH3 Alert occurrence flag	CH3 Alert occurrence flag
XnF	CH4 Alert occurrence flag	CH4 Alert occurrence flag	CH4 Alert occurrence flag	CH4 Alert occurrence flag

*1 Available only under the heating-cooling control (expanded mode). For details on the expanded mode, refer to  Page 127, Section 8.2.1 (3).

*2 Available only under the mix control (expanded mode). For details on the expanded mode, refer to  Page 127, Section 8.2.1 (3).

(2) Output signal list

Output signal (signal direction: CPU module → L60TC4)				
Device No.	Temperature input mode	Standard control	Heating-cooling control	Mix control
Yn0	N/A	N/A	N/A	N/A
Yn1	Setting/operation mode status	Setting/operation mode instruction	Setting/operation mode instruction	Setting/operation mode instruction
Yn2	Error reset instruction	Error reset instruction	Error reset instruction	Error reset instruction
Yn3	N/A	N/A	N/A	N/A
Yn4	N/A	CH1 Auto tuning instruction	CH1 Auto tuning instruction	CH1 Auto tuning instruction
Yn5	N/A	CH2 Auto tuning instruction	CH2 Auto tuning instruction	CH2 Auto tuning instruction ^{*2}
Yn6	N/A	CH3 Auto tuning instruction	CH3 Auto tuning instruction ^{*1}	CH3 Auto tuning instruction
Yn7	N/A	CH4 Auto tuning instruction	CH4 Auto tuning instruction ^{*1}	CH4 Auto tuning instruction
Yn8	Set value backup instruction	Set value backup instruction	Set value backup instruction	Set value backup instruction
Yn9	Default setting registration instruction	Default setting registration instruction	Default setting registration instruction	Default setting registration instruction
YnA	N/A	N/A	N/A	N/A
YnB	Setting change instruction	Setting change instruction	Setting change instruction	Setting change instruction
YnC	N/A	CH1 PID control forced stop instruction	CH1 PID control forced stop instruction	CH1 PID control forced stop instruction
YnD	N/A	CH2 PID control forced stop instruction	CH2 PID control forced stop instruction	CH2 PID control forced stop instruction ^{*2}
YnE	N/A	CH3 PID control forced stop instruction	CH3 PID control forced stop instruction ^{*1}	CH3 PID control forced stop instruction
YnF	N/A	CH4 PID control forced stop instruction	CH4 PID control forced stop instruction ^{*1}	CH4 PID control forced stop instruction

*1 Available only under the heating-cooling control (expanded mode). For details on the expanded mode, refer to  Page 127, Section 8.2.1 (3).

*2 Available only under the mix control (expanded mode). For details on the expanded mode, refer to  Page 127, Section 8.2.1 (3).

Point 

The functions of the L60TC4 cannot be guaranteed if any of the unavailable areas is turned on/off in a program.

3.5 Buffer Memory List

This section lists the L60TC4 buffer memory areas.

For details on the buffer memory, refer to  Page 334, Appendix 2.

Point

Do not write data in the system area or the write-protect area in a program in the buffer memory. Doing so may cause malfunction.

(1) Buffer memory address by mode

This section describes the buffer memory assignments by mode.

For details on the modes, refer to  Page 116, Section 8.1, Page 126, Section 8.2.1.

Point

Depending on the control mode, some channels cannot be used for control under the temperature control mode.

The channels which cannot be used for control are the following.

- For heating-cooling control (normal mode): CH3, CH4
- For mix control (normal mode): CH2

The channels which cannot be used for control can be used only for temperature input. For details, refer to

 Page 212, Section 8.2.23.

(a) In the temperature input mode

○: Enable, ×: Disable

Address (decimal (hexadecimal))	Target channel	Setting contents	Default value* ¹	Read/Write * ²	Automatic setting* ³	Non-volatile memory write availability* ⁴	Reference
		Temperature input mode					
0(0 _H)	All CHs	Error code	0	R	×	×	Page 334, Appendix 2 (1)
1(1 _H)	CH1	Decimal point position	0(TT) 1(RT) * ⁵	R	×	×	Page 334, Appendix 2 (2)
2(2 _H)	CH2	Decimal point position					
3(3 _H)	CH3	Decimal point position					
4(4 _H)	CH4	Decimal point position					
5(5 _H)	CH1	Alert definition	0	R	×	×	Page 336, Appendix 2 (3)
6(6 _H)	CH2	Alert definition					
7(7 _H)	CH3	Alert definition					
8(8 _H)	CH4	Alert definition					
9(9 _H)	CH1	Temperature process value (PV)	0	R	×	×	Page 338, Appendix 2 (4)
10(A _H)	CH2	Temperature process value (PV)					
11(B _H)	CH3	Temperature process value (PV)					
12(C _H)	CH4	Temperature process value (PV)					
13(D _H) to 28(1C _H)	—	System area	—	—	—	—	—
29(1D _H)	All CHs	Cold junction temperature process value* ⁶	0	R	×	×	Page 342, Appendix 2 (9)
30(1E _H)	All CHs	System area	—	—	—	—	—
31(1F _H)	All CHs	System area	—	—	—	—	—
32(20 _H)	CH1	Input range* ⁷	2(TT) 7(RT) * ⁵	R/W	×	○	Page 345, Appendix 2 (12)
33(21 _H) to 44(2C _H)	—	System area	—	—	—	—	—
45(2D _H)	CH1	Sensor correction value setting	0	R/W	×	○	Page 363, Appendix 2 (21)
46(2E _H)	—	System area	—	—	—	—	—
47(2F _H)	—	System area	—	—	—	—	—
48(30 _H)	CH1	Primary delay digital filter setting	0	R/W	×	○	Page 365, Appendix 2 (24)
49(31 _H) to 63(3F _H)	—	System area	—	—	—	—	—
64(40 _H)	CH2	Input range* ⁷	2(TT) 7(RT) * ⁵	R/W	×	○	Page 345, Appendix 2 (12)
65(41 _H) to 76(4C _H)	—	System area	—	—	—	—	—

Address (decimal (hexadecimal))	Target channel	Setting contents	Default value *1	Read/Write *2	Automatic setting *3	Non-volatile memory write availability *4	Reference
		Temperature input mode					
77(4D _H)	CH2	Sensor correction value setting	0	R/W	×	○	Page 363, Appendix 2 (21)
78(4E _H)	CH2	System area	—	—	—	—	—
79(4F _H)	CH2	System area	—	—	—	—	—
80(50 _H)	CH2	Primary delay digital filter setting	0	R/W	×	○	Page 365, Appendix 2 (24)
81(51 _H) to 95(5F _H)	—	System area	—	—	—	—	—
96(60 _H)	CH3	Input range*7	2(TT) 7(RT) *5	R/W	×	○	Page 345, Appendix 2 (12)
97(61 _H) to 108(6C _H)	—	System area	—	—	—	—	—
109(6D _H)	CH3	Sensor correction value setting	0	R/W	×	○	Page 363, Appendix 2 (21)
110(6E _H)	CH3	System area	—	—	—	—	—
111(6F _H)	CH3	System area	—	—	—	—	—
112(70 _H)	CH3	Primary delay digital filter setting	0	R/W	×	○	Page 365, Appendix 2 (24)
113(71 _H) to 127(7F _H)	—	System area	—	—	—	—	—
128(80 _H)	CH4	Input range*7	2(TT) 7(RT) *5	R/W	×	○	Page 345, Appendix 2 (12)
129(81 _H) to 140(8C _H)	—	System area	—	—	—	—	—
141(8D _H)	CH4	Sensor correction value setting	0	R/W	×	○	Page 363, Appendix 2 (21)
142(8E _H)	CH4	System area	—	—	—	—	—
143(8F _H)	CH4	System area	—	—	—	—	—
144(90 _H)	CH4	Primary delay digital filter setting	0	R/W	×	○	Page 365, Appendix 2 (24)
145(91 _H) to 181(B5 _H)	—	System area	—	—	—	—	—
182(B6 _H)	All	Cold junction temperature compensation selection*6	0	R/W	×	○	Page 384, Appendix 2 (49)
183(B7 _H)	All	Control switching monitor	0	R	×	×	Page 385, Appendix 2 (50)
184(B8 _H) to 195(C3 _H)	—	System area	—	—	—	—	—
196(C4 _H)	CH1	Process alarm alert output enable/disable setting*7	1	R/W	×	○	Page 387, Appendix 2 (53)



Address (decimal (hexadecimal))	Target channel	Setting contents	Default value ^{*1}	Read/Write ^{*2}	Automatic setting ^{*3}	Non-volatile memory write availability ^{*4}	Reference
		Temperature input mode					
197(C5 _H)	CH1	Process alarm lower lower limit value ^{*7}	0(TT) -2000(RT) ^{*5}	R/W	○	○	Page 388, Appendix 2 (54)
198(C6 _H)	CH1	Process alarm lower upper limit value ^{*7}	0(TT) -2000(RT) ^{*5}	R/W	○	○	
199(C7 _H)	CH1	Process alarm upper lower limit value ^{*7}	1300(TT) 6000(RT) ^{*5}	R/W	○	○	
200(C8 _H)	CH1	Process alarm upper upper limit value ^{*7}	1300(TT) 6000(RT) ^{*5}	R/W	○	○	
201(C9 _H)	CH1	Rate alarm alert output enable/disable setting ^{*7}	1	R/W	×	○	Page 389, Appendix 2 (55)
202(CA _H)	CH1	Rate alarm alert detection cycle ^{*7}	1	R/W	×	○	Page 389, Appendix 2 (56)
203(CB _H)	CH1	Rate alarm upper limit value ^{*7}	0	R/W	×	○	Page 390, Appendix 2 (57)
204(CC _H)	CH1	Rate alarm lower limit value ^{*7}	0	R/W	×	○	
205(CD _H) to 211(D3 _H)	—	System area	—	—	—	—	—
212(D4 _H)	CH2	Process alarm alert output enable/disable setting ^{*7}	1	R/W	×	○	Page 387, Appendix 2 (53)
213(D5 _H)	CH2	Process alarm lower lower limit value ^{*7}	0(TT) -2000(RT) ^{*5}	R/W	○	○	Page 388, Appendix 2 (54)
214(D6 _H)	CH2	Process alarm lower upper limit value ^{*7}	0(TT) -2000(RT) ^{*5}	R/W	○	○	
215(D7 _H)	CH2	Process alarm upper lower limit value ^{*7}	1300(TT) 6000(RT) ^{*5}	R/W	○	○	
216(D8 _H)	CH2	Process alarm upper upper limit value ^{*7}	1300(TT) 6000(RT) ^{*5}	R/W	○	○	
217(D9 _H)	CH2	Rate alarm alert output enable/disable setting ^{*7}	1	R/W	×	○	Page 389, Appendix 2 (55)
218(DA _H)	CH2	Rate alarm alert detection cycle ^{*7}	1	R/W	×	○	Page 389, Appendix 2 (56)
219(DB _H)	CH2	Rate alarm upper limit value ^{*7}	0	R/W	×	○	Page 390, Appendix 2 (57)
220(DC _H)	CH2	Rate alarm lower limit value ^{*7}	0	R/W	×	○	
221(DD _H) to 227(E3 _H)	—	System area	—	—	—	—	—
228(E4 _H)	CH3	Process alarm alert output enable/disable setting ^{*7}	1	R/W	×	○	Page 387, Appendix 2 (53)

Address (decimal (hexadecimal))	Target channel	Setting contents	Default value *1	Read/Write *2	Automatic setting *3	Non-volatile memory write availability *4	Reference
		Temperature input mode					
229(E5 _H)	CH3	Process alarm lower lower limit value*7	0(TT) -2000(RT) *5	R/W	○	○	Page 388, Appendix 2 (54)
230(E6 _H)	CH3	Process alarm lower upper limit value*7	0(TT) -2000(RT) *5	R/W	○	○	
231(E7 _H)	CH3	Process alarm upper lower limit value*7	1300(TT) 6000(RT) *5	R/W	○	○	
232(E8 _H)	CH3	Process alarm upper upper limit value*7	1300(TT) 6000(RT) *5	R/W	○	○	
233(E9 _H)	CH3	Rate alarm alert output enable/disable setting*7	1	R/W	×	○	Page 389, Appendix 2 (55)
234(EA _H)	CH3	Rate alarm alert detection cycle*7	1	R/W	×	○	Page 389, Appendix 2 (56)
235(EB _H)	CH3	Rate alarm upper limit value*7	0	R/W	×	○	Page 390, Appendix 2 (57)
236(EC _H)	CH3	Rate alarm lower limit value*7	0	R/W	×	○	
237(ED _H) to 243(F3 _H)	—	System area	—	—	—	—	—
244(F4 _H)	CH4	Process alarm alert output enable/disable setting*7	1	R/W	×	○	Page 387, Appendix 2 (53)
245(F5 _H)	CH4	Process alarm lower lower limit value*7	0(TT) -2000(RT) *5	R/W	○	○	Page 388, Appendix 2 (54)
246(F6 _H)	CH4	Process alarm lower upper limit value*7	0(TT) -2000(RT) *5	R/W	○	○	
247(F7 _H)	CH4	Process alarm upper lower limit value*7	1300(TT) 6000(RT) *5	R/W	○	○	
248(F8 _H)	CH4	Process alarm upper upper limit value*7	1300(TT) 6000(RT) *5	R/W	○	○	
249(F9 _H)	CH4	Rate alarm alert output enable/disable setting*7	1	R/W	×	○	Page 389, Appendix 2 (55)
250(FA _H)	CH4	Rate alarm alert detection cycle*7	1	R/W	×	○	Page 389, Appendix 2 (56)
251(FB _H)	CH4	Rate alarm upper limit value*7	0	R/W	×	○	Page 390, Appendix 2 (57)
252(FC _H)	CH4	Rate alarm lower limit value*7	0	R/W	×	○	
253(FD _H) to 543(21F _H)	—	System area	—	—	—	—	—
544(220 _H)	CH1	2-point sensor compensation offset value (measured value)*7	0	R/W	○	○	Page 394, Appendix 2 (63)
545(221 _H)	CH1	2-point sensor compensation offset value(compensation value)*7	0	R/W	○	○	Page 394, Appendix 2 (64)
546(222 _H)	CH1	2-point sensor compensation gain value (measured value)*7	0	R/W	○	○	Page 395, Appendix 2 (65)

Address (decimal (hexadecimal))	Target channel	Setting contents	Default value ^{*1}	Read/Write ^{*2}	Automatic setting ^{*3}	Non-volatile memory write availability ^{*4}	Reference
		Temperature input mode					
547(223 _H)	CH1	2-point sensor compensation gain value (compensation value) ^{*7}	0	R/W	○	○	Page 395, Appendix 2 (66)
548(224 _H)	CH1	2-point sensor compensation offset latch request ^{*7}	0	R/W	×	×	Page 396, Appendix 2 (67)
549(225 _H)	CH1	2-point sensor compensation offset latch completion	0	R	×	×	Page 396, Appendix 2 (68)
550(226 _H)	CH1	2-point sensor compensation gain latch request ^{*7}	0	R/W	×	×	Page 397, Appendix 2 (69)
551(227 _H)	CH1	2-point sensor compensation gain latch completion	0	R	×	×	Page 397, Appendix 2 (70)
552(228 _H) to 575(23F _H)	—	System area	—	—	—	—	—
576(240 _H)	CH2	2-point sensor compensation (measured value) ^{*7}	0	R/W	○	○	Page 394, Appendix 2 (63)
577(241 _H)	CH2	2-point sensor compensation offset value (compensation value) ^{*7}	0	R/W	○	○	Page 394, Appendix 2 (64)
578(242 _H)	CH2	2-point sensor compensation gain value (measured value) ^{*7}	0	R/W	○	○	Page 395, Appendix 2 (65)
579(243 _H)	CH2	2-point sensor compensation (compensation value) ^{*7}	0	R/W	○	○	Page 395, Appendix 2 (66)
580(244 _H)	CH2	2-point sensor compensation offset latch request ^{*7}	0	R/W	×	×	Page 396, Appendix 2 (67)
581(245 _H)	CH2	2-point sensor compensation offset latch completion	0	R	×	×	Page 396, Appendix 2 (68)
582(246 _H)	CH2	2-point sensor compensation gain latch request ^{*7}	0	R/W	×	×	Page 397, Appendix 2 (69)
583(247 _H)	CH2	2-point sensor compensation gain latch completion	0	R	×	×	Page 397, Appendix 2 (70)
584(248 _H) to 607(25F _H)	—	System area	—	—	—	—	—
608(260 _H)	CH3	2-point sensor compensation offset value (measured value) ^{*7}	0	R/W	○	○	Page 394, Appendix 2 (63)
609(261 _H)	CH3	2-point sensor compensation offset value (compensation value) ^{*7}	0	R/W	○	○	Page 394, Appendix 2 (64)
610(262 _H)	CH3	2-point sensor compensation gain value (measured value) ^{*7}	0	R/W	○	○	Page 395, Appendix 2 (65)
611(263 _H)	CH3	2-point sensor compensation gain value (compensation value) ^{*7}	0	R/W	○	○	Page 395, Appendix 2 (66)
612(264 _H)	CH3	2-point sensor compensation offset latch request ^{*7}	0	R/W	×	×	Page 396, Appendix 2 (67)
613(265 _H)	CH3	2-point sensor compensation offset latch completion	0	R	×	×	Page 396, Appendix 2 (68)
614(266 _H)	CH3	2-point sensor compensation gain latch request ^{*7}	0	R/W	×	×	Page 397, Appendix 2 (69)
615(267 _H)	CH3	2-point sensor compensation gain latch completion	0	R	×	×	Page 397, Appendix 2 (70)

Address (decimal (hexadecimal))	Target channel	Setting contents	Default value *1	Read/Write *2	Automatic setting *3	Non-volatile memory write availability *4	Reference
		Temperature input mode					
616(268 _H) to 639(27F _H)	—	System area	—	—	—	—	—
640(280 _H)	CH4	2-point sensor compensation offset value (measured value) ^{*7}	0	R/W	○	○	Page 394, Appendix 2 (63)
641(281 _H)	CH4	2-point sensor compensation offset value (compensation value) ^{*7}	0	R/W	○	○	Page 394, Appendix 2 (64)
642(282 _H)	CH4	2-point sensor compensation gain value (measured value) ^{*7}	0	R/W	○	○	Page 395, Appendix 2 (65)
643(283 _H)	CH4	2-point sensor compensation gain value (compensation value) ^{*7}	0	R/W	○	○	Page 395, Appendix 2 (66)
644(284 _H)	CH4	2-point sensor compensation offset latch request ^{*7}	0	R/W	×	×	Page 396, Appendix 2 (67)
645(285 _H)	CH4	2-point sensor compensation offset latch completion	0	R	×	×	Page 396, Appendix 2 (68)
646(286 _H)	CH4	2-point sensor compensation gain latch request ^{*7}	0	R/W	×	×	Page 397, Appendix 2 (69)
647(287 _H)	CH4	2-point sensor compensation gain latch completion	0	R	×	×	Page 397, Appendix 2 (70)
648(288 _H) to 692(2B4 _H)	—	System area	—	—	—	—	—
693(2B5 _H)	All CHs	Conversion enable/disable setting ^{*7}	000F _H	R/W	×	○	Page 402, Appendix 2 (75)
694(2B6 _H) to 724(2D4 _H)	—	System area	—	—	—	—	—
725(2D5 _H)	CH1	Process value (PV) scaling function enable/disable setting ^{*7}	0	R/W	×	○	Page 405, Appendix 2 (80)
726(2D6 _H)	CH1	Process value (PV) scaling lower limit value ^{*7}	0	R/W	×	○	Page 406, Appendix 2 (81)
727(2D7 _H)	CH1	Process value (PV) scaling upper limit value ^{*7}	0	R/W	×	○	
728(2D8 _H)	CH1	Process value (PV) scaling value	0	R	×	×	Page 406, Appendix 2 (82)
729(2D9 _H) to 740(2E4 _H)	—	System area	—	—	—	—	—
741(2E5 _H)	CH2	Process value (PV) scaling function enable/disable setting ^{*7}	0	R/W	×	○	Page 405, Appendix 2 (80)
742(2E6 _H)	CH2	Process value (PV) scaling lower limit value ^{*7}	0	R/W	×	○	Page 406, Appendix 2 (81)
743(2E7 _H)	CH2	Process value (PV) scaling upper limit value ^{*7}	0	R/W	×	○	
744(2E8 _H)	CH2	Process value (PV) scaling value	0	R	×	×	Page 406, Appendix 2 (82)

Address (decimal (hexadecimal))	Target channel	Setting contents	Default value *1	Read/Write *2	Automatic setting *3	Non-volatile memory write availability *4	Reference
		Temperature input mode					
745(2E9 _H) to 756(2F4 _H)	—	System area	—	—	—	—	—
757(2F5 _H)	CH3	Process value (PV) scaling function enable/disable setting *7	0	R/W	×	○	Page 405, Appendix 2 (80)
758(2F6 _H)	CH3	Process value (PV) scaling lower limit value *7	0	R/W	×	○	Page 406, Appendix 2 (81)
759(2F7 _H)	CH3	Process value (PV) scaling upper limit value *7	0	R/W	×	○	
760(2F8 _H)	CH3	Process value (PV) scaling value	0	R	×	×	Page 406, Appendix 2 (82)
761(2F9 _H) to 772(304 _H)	—	System area	—	—	—	—	—
773(305 _H)	CH4	Process value (PV) scaling function enable/disable setting *7	0	R/W	×	○	Page 405, Appendix 2 (80)
774(306 _H)	CH4	Process value (PV) scaling lower limit value *7	0	R/W	×	○	Page 406, Appendix 2 (81)
775(307 _H)	CH4	Process value (PV) scaling upper limit value *7	0	R/W	×	○	
776(308 _H)	CH4	Process value (PV) scaling value	0	R	×	×	Page 406, Appendix 2 (82)
777(309 _H) to 784(310 _H)	—	System area	—	—	—	—	—
785(311 _H)	All CHs	Sensor compensation function selection *7	0	R/W	×	○	Page 413, Appendix 2 (91)
786(312 _H)	All CHs	Temperature conversion completion flag	0	R	×	×	Page 413, Appendix 2 (92)
787(313 _H)	All CHs	Function extension bit monitor	0	R	×	×	Page 414, Appendix 2 (93)
788(314 _H)	All CHs	Sampling cycle monitor	0	R	×	×	Page 414, Appendix 2 (94)
789(315 _H) to 1278(4FE _H)	—	System area	—	—	—	—	—
1279(4FF _H) to 4095(FFF _H)	Buffer memory areas for error history (☞ Page 76, Section 3.5 (2))						
4096(1000 _H) to 53247(CFFF _H)	—	System area	—	—	—	—	—

- *1 This default value is set after the module is turned off and on or after the CPU module is reset and the reset is cancelled.
- *2 This column indicates whether data can be read from or written to the buffer memory area through sequence programs.
R: Reading enabled
W: Writing enabled
- *3 This column indicates whether the setting in the buffer memory area is automatically changed when the input range is changed. Enable/disable of automatic change can be set on Switch Setting. For details, refer to  Page 234, Section 8.3.3.
- *4 Whether writing to the non-volatile memory by turning off and on Set value backup instruction (Yn8) is enabled in this column. For details, refer to  Page 235, Section 8.3.4.
- *5 (TT) indicates the L60TCTT4 and L60TCTT4BW. (RT) indicates the L60TCRT4 and L60TCRT4BW.
- *6 Available only when the L60TCTT4 or L60TCTT4BW is used. With other models, this area is handled as a system area.
- *7 Available only in the setting mode. To enable the setting contents, turn off, on, and off Setting change instruction (YnB) when Setting/operation mode instruction (Yn1) is off (during setting mode). Note that a write data error (error code: □□□3H) occurs if the setting is changed during the operation mode.

(b) In the temperature control mode

○: Enable, ×: Disable

Address (decimal (hexadecimal))	Target channel or current sensor (CT)	Setting contents			Default value *1	Read/ Write *2	Automatic setting *3	Non- volatile memory write availability *4	Reference
		Standard control	Heating- cooling control	Mix control					
0(0 _H)	All CHs	Error code			0	R	×	×	Page 334, Appendix 2 (1)
1(1 _H)	CH1	Decimal point position			0(TT) 1(RT) *5	R	×	×	Page 334, Appendix 2 (2)
2(2 _H)	CH2	Decimal point position							
3(3 _H)	CH3	Decimal point position							
4(4 _H)	CH4	Decimal point position							
5(5 _H)	CH1	Alert definition			0	R	×	×	Page 336, Appendix 2 (3)
6(6 _H)	CH2	Alert definition							
7(7 _H)	CH3	Alert definition							
8(8 _H)	CH4	Alert definition							
9(9 _H)	CH1	Temperature process value (PV)			0	R	×	×	Page 338, Appendix 2 (4)
10(A _H)	CH2	Temperature process value (PV)							
11(B _H)	CH3	Temperature process value (PV)							
12(C _H)	CH4	Temperature process value (PV)							
13(D _H)	CH1	Manipulated value (MV)	Manipulated value for heating (MVh)	Manipulated value for heating (MVh)	0	R	×	×	Page 339, Appendix 2 (5)
14(E _H)	CH2	Manipulated value (MV)	Manipulated value for heating (MVh)	Manipulated value for heating (MVh)*7					
15(F _H)	CH3	Manipulated value (MV)	Manipulated value for heating (MVh)*6	Manipulated value (MV)					
16(10 _H)	CH4	Manipulated value (MV)	Manipulated value for heating (MVh)*6	Manipulated value (MV)					
17(11 _H)	CH1	Temperature rise judgment flag	Temperature rise judgment flag	Temperature rise judgment flag	0	R	×	×	Page 340, Appendix 2 (6)
18(12 _H)	CH2	Temperature rise judgment flag	Temperature rise judgment flag	Temperature rise judgment flag*7					
19(13 _H)	CH3	Temperature rise judgment flag	Temperature rise judgment flag *6	Temperature rise judgment flag					
20(14 _H)	CH4	Temperature rise judgment flag	Temperature rise judgment flag *6	Temperature rise judgment flag					

Address (decimal (hexadecimal))	Target channel or current sensor (CT)	Setting contents			Default value *1	Read/ Write *2	Automatic setting *3	Non- volatile memory write availability *4	Reference
		Standard control	Heating- cooling control	Mix control					
21(15 _H)	CH1	Transistor output flag	Heating transistor output flag	Heating transistor output flag	0	R	×	×	Page 341, Appendix 2 (7)
22(16 _H)	CH2	Transistor output flag	Heating transistor output flag	Heating transistor output flag ^{*7}					
23(17 _H)	CH3	Transistor output flag	Heating transistor output flag ^{*6}	Transistor output flag					
24(18 _H)	CH4	Transistor output flag	Heating transistor output flag ^{*6}	Transistor output flag					
25(19 _H)	CH1	Set value (SV) monitor			0	R	×	×	Page 342, Appendix 2 (8)
26(1A _H)	CH2	Set value (SV) monitor	Set value (SV) monitor	Set value (SV) monitor ^{*7}					
27(1B _H)	CH3	Set value (SV) monitor	Set value (SV) monitor ^{*6}	Set value (SV) monitor					
28(1C _H)	CH4	Set value (SV) monitor	Set value (SV) monitor ^{*6}	Set value (SV) monitor					
29(1D _H)	All CHs	Cold junction temperature process value ^{*8}			0	R	×	×	Page 342, Appendix 2 (9)
30(1E _H)	All CHs	MAN mode shift completion flag			0	R	×	×	Page 342, Appendix 2 (10)
31(1F _H)	All CHs	Memory of PID constants read/Write completion flag			0	R	×	×	Page 343, Appendix 2 (11)
32(20 _H)	CH1	Input range ^{*9}			2(TT) 7(RT) *5	R/W	×	○	Page 345, Appendix 2 (12)
33(21 _H)	CH1	Stop mode setting			1	R/W	×	○	Page 353, Appendix 2 (13)
34(22 _H)	CH1	Set value (SV) setting			0	R/W	○	○	Page 354, Appendix 2 (14)
35(23 _H)	CH1	Proportional band (P) setting	Heating proportional band (Ph) setting	Heating proportional band (Ph) setting	30	R/W	×	○	Page 355, Appendix 2 (15)
36(24 _H)	CH1	Integral time (I) setting			240	R/W	×	○	Page 357, Appendix 2 (16)
37(25 _H)	CH1	Derivative time (D) setting			60	R/W	×	○	Page 357, Appendix 2 (17)
38(26 _H)	CH1	Alert set value 1			0	R/W	○	○	Page 358, Appendix 2 (18)
39(27 _H)	CH1	Alert set value 2			0	R/W	○	○	
40(28 _H)	CH1	Alert set value 3			0	R/W	○	○	
41(29 _H)	CH1	Alert set value 4			0	R/W	○	○	

Address (decimal (hexadecimal))	Target channel or current sensor (CT)	Setting contents			Default value *1	Read/ Write *2	Automatic setting *3	Non- volatile memory write availability *4	Reference
		Standard control	Heating- cooling control	Mix control					
42(2A _H)	CH1	Upper limit output limiter	Heating upper limit output limiter	Heating upper limit output limiter	1000	R/W	×	○	Page 360, Appendix 2 (19)
43(2B _H)	CH1	Lower limit output limiter	System area	System area	0	R/W	×	○	
44(2C _H)	CH1	Output variation limiter setting			0	R/W	×	○	Page 362, Appendix 2 (20)
45(2D _H)	CH1	Sensor correction value setting			0	R/W	×	○	Page 363, Appendix 2 (21)
46(2E _H)	CH1	Adjustment sensitivity (dead band) setting			5	R/W	×	○	Page 363, Appendix 2 (22)
47(2F _H)	CH1	Control output cycle setting	Heating control output cycle setting	Heating control output cycle setting	30/300	R/W	×	○	Page 364, Appendix 2 (23)
48(30 _H)	CH1	Primary delay digital filter setting			0	R/W	×	○	Page 365, Appendix 2 (24)
49(31 _H)	CH1	Control response parameters			0	R/W	×	○	Page 366, Appendix 2 (25)
50(32 _H)	CH1	AUTO/MAN mode shift			0	R/W	×	○	Page 367, Appendix 2 (26)
51(33 _H)	CH1	MAN output setting			0	R/W	×	○	Page 368, Appendix 2 (27)
52(34 _H)	CH1	Setting change rate limiter/Setting change rate limiter (temperature rise)*10			0	R/W	×	○	Page 369, Appendix 2 (28)
53(35 _H)	CH1	AT bias			0	R/W	○	○	Page 370, Appendix 2 (29)
54(36 _H)	CH1	Forward/reverse action setting	System area	System area	1	R/W	×	○	Page 371, Appendix 2 (30)
55(37 _H)	CH1	Upper limit setting limiter			1300 (TT) 6000 (RT) *5	R/W	○	○	Page 372, Appendix 2 (31)
56(38 _H)	CH1	Lower limit setting limiter			0(TT) -2000 (RT) *5	R/W	○	○	
57(39 _H)	CH1	System area			—	—	—	—	—
58(3A _H)	CH1	Heater disconnection alert setting*11			0	R/W	×	○	Page 373, Appendix 2 (32)
59(3B _H)	CH1	Loop disconnection detection judgment time	System area	System area	480	R/W	×	○	Page 374, Appendix 2 (33)

Address (decimal (hexadecimal))	Target channel or current sensor (CT)	Setting contents			Default value *1	Read/ Write *2	Automatic setting *3	Non- volatile memory write availability *4	Reference
		Standard control	Heating- cooling control	Mix control					
60(3C _H)	CH1	Loop disconnection detection dead band	System area	System area	0	R/W	○	○	Page 375, Appendix 2 (34)
61(3D _H)	CH1	Unused channel setting			0	R/W	×	○	Page 376, Appendix 2 (35)
62(3E _H)	CH1	Memory of PID constants read instruction			0	R/W	×	×	Page 377, Appendix 2 (36)
63(3F _H)	CH1	Automatic backup setting after auto tuning of PID constants			0	R/W	×	×	Page 378, Appendix 2 (37)
64(40 _H)	CH2	Input range ^{*9}			2(TT) 7(RT) *5	R/W	×	○	Page 345, Appendix 2 (12)
65(41 _H)	CH2	Stop mode setting	Stop mode setting	Stop mode setting ^{*7}	1	R/W	×	○	Page 353, Appendix 2 (13)
66(42 _H)	CH2	Set value (SV) setting	Set value (SV) setting	Set value (SV) setting ^{*7}	0	R/W	○	○	Page 354, Appendix 2 (14)
67(43 _H)	CH2	Proportional band (P) setting	Heating proportional band (Ph) setting	Heating proportional band (Ph) setting ^{*7}	30	R/W	×	○	Page 355, Appendix 2 (15)
68(44 _H)	CH2	Integral time (I) setting	Integral time (I) setting	Integral time (I) setting ^{*7}	240	R/W	×	○	Page 357, Appendix 2 (16)
69(45 _H)	CH2	Derivative time (D) setting	Derivative time (D) setting	Derivative time (D) setting ^{*7}	60	R/W	×	○	Page 357, Appendix 2 (17)
70(46 _H)	CH2	Alert set value 1	Alert set value 1	Alert set value 1 ^{*7}	0	R/W	○	○	Page 358, Appendix 2 (18)
71(47 _H)	CH2	Alert set value 2	Alert set value 2	Alert set value 2 ^{*7}	0	R/W	○	○	
72(48 _H)	CH2	Alert set value 3	Alert set value 3	Alert set value 3 ^{*7}	0	R/W	○	○	
73(49 _H)	CH2	Alert set value 4	Alert set value 4	Alert set value 4 ^{*7}	0	R/W	○	○	
74(4A _H)	CH2	Upper limit output limiter	Heating upper limit output limiter	Heating upper limit output limiter ^{*7}	1000	R/W	×	○	Page 360, Appendix 2 (19)
75(4B _H)	CH2	Lower limit output limiter	System area	System area	0	R/W	×	○	
76(4C _H)	CH2	Output variation limiter setting	Output variation limiter setting	Output variation limiter setting ^{*7}	0	R/W	×	○	Page 362, Appendix 2 (20)
77(4D _H)	CH2	Sensor correction value setting			0	R/W	×	○	Page 363, Appendix 2 (21)
78(4E _H)	CH2	Adjustment sensitivity (dead band) setting	Adjustment sensitivity (dead band) setting	Adjustment sensitivity (dead band) setting ^{*7}	5	R/W	×	○	Page 363, Appendix 2 (22)

Address (decimal (hexadecimal))	Target channel or current sensor (CT)	Setting contents			Default value *1	Read/ Write *2	Automatic setting *3	Non- volatile memory write availability *4	Reference
		Standard control	Heating- cooling control	Mix control					
79(4F _H)	CH2	Control output cycle setting	Heating control output cycle setting	Heating control output cycle setting*7	30/300	R/W	×	○	Page 364, Appendix 2 (23)
80(50 _H)	CH2	Primary delay digital filter setting			0	R/W	×	○	Page 365, Appendix 2 (24)
81(51 _H)	CH2	Control response parameters	Control response parameters	Control response parameters*7	0	R/W	×	○	Page 366, Appendix 2 (25)
82(52 _H)	CH2	AUTO/MAN mode shift	AUTO/MAN mode shift	AUTO/MAN mode shift *7	0	R/W	×	○	Page 367, Appendix 2 (26)
83(53 _H)	CH2	MAN output setting	MAN output setting	MAN output setting *7	0	R/W	×	○	Page 368, Appendix 2 (27)
84(54 _H)	CH2	Setting change rate limiter/Setting change rate limiter (temperature rise) *10			0	R/W	×	○	Page 369, Appendix 2 (28)
85(55 _H)	CH2	AT bias	AT bias	AT bias*7	0	R/W	○	○	Page 370, Appendix 2 (29)
86(56 _H)	CH2	Forward/reverse action setting	System area	System area	1	R/W	×	○	Page 371, Appendix 2 (30)
87(57 _H)	CH2	Upper limit setting limiter	Upper limit setting limiter	Upper limit setting limiter*7	1300 (TT) 6000 (RT) *5	R/W	○	○	Page 372, Appendix 2 (31)
88(58 _H)	CH2	Lower limit setting limiter	Lower limit setting limiter	Lower limit setting limiter*7	0 (TT) -2000 (RT) *5	R/W	○	○	
89(59 _H)	CH2	System area			—	—	—	—	—
90(5A _H)	CH2	Heater disconnection alert setting*11	Heater disconnection alert setting*11	Heater disconnection alert setting*7*11	0	R/W	×	○	Page 373, Appendix 2 (32)
91(5B _H)	CH2	Loop disconnection detection judgment time	System area	System area	480	R/W	×	○	Page 374, Appendix 2 (33)
92(5C _H)	CH2	Loop disconnection detection dead band	System area	System area	0	R/W	○	○	Page 375, Appendix 2 (34)
93(5D _H)	CH2	Unused channel setting	Unused channel setting	Unused channel setting*7	0	R/W	×	○	Page 376, Appendix 2 (35)
94(5E _H)	CH2	Memory of PID constants read instruction	Memory of PID constants read instruction	Memory of PID constants read instruction*7	0	R/W	×	×	Page 377, Appendix 2 (36)

Address (decimal (hexadecimal))	Target channel or current sensor (CT)	Setting contents			Default value *1	Read/ Write *2	Automatic setting *3	Non- volatile memory write availability *4	Reference
		Standard control	Heating- cooling control	Mix control					
95(5F _H)	CH2	Automatic backup setting after auto tuning of PID constants	Automatic backup setting after auto tuning of PID constants	Automatic backup setting after auto tuning of PID constants*7	0	R/W	×	×	Page 378, Appendix 2 (37)
96(60 _H)	CH3	Input range*9			2(TT) 7(RT) *5	R/W	×	○	Page 345, Appendix 2 (12)
97(61 _H)	CH3	Stop mode setting	Stop mode setting *6	Stop mode setting	1	R/W	×	○	Page 353, Appendix 2 (13)
98(62 _H)	CH3	Set value (SV) setting	Set value (SV) setting*6	Set value (SV) setting	0	R/W	○	○	Page 354, Appendix 2 (14)
99(63 _H)	CH3	Proportional band (P) setting	Heating proportional band (Ph) setting*6	Proportional band (P) setting	30	R/W	×	○	Page 355, Appendix 2 (15)
100(64 _H)	CH3	Integral time (I) setting	Integral time (I) setting*6	Integral time (I) setting	240	R/W	×	○	Page 357, Appendix 2 (16)
101(65 _H)	CH3	Derivative time (D) setting	Derivative time (D) setting*6	Derivative time (D) setting	60	R/W	×	○	Page 357, Appendix 2 (17)
102(66 _H)	CH3	Alert set value 1	Alert set value 1*6	Alert set value 1	0	R/W	○	○	Page 358, Appendix 2 (18)
103(67 _H)	CH3	Alert set value 2	Alert set value 2*6	Alert set value 2	0	R/W	○	○	
104(68 _H)	CH3	Alert set value 3	Alert set value 3*6	Alert set value 3	0	R/W	○	○	
105(69 _H)	CH3	Alert set value 4	Alert set value 4*6	Alert set value 4	0	R/W	○	○	
106(6A _H)	CH3	Upper limit output limiter	Heating upper limit output limiter*6	Upper limit output limiter	1000	R/W	×	○	Page 360, Appendix 2 (19)
107(6B _H)	CH3	Lower limit output limiter	System area	Lower limit output limiter	0	R/W	×	○	
108(6C _H)	CH3	Output variation limiter setting	Output variation limiter setting*6	Output variation limiter setting	0	R/W	×	○	Page 362, Appendix 2 (20)
109(6D _H)	CH3	Sensor correction value setting			0	R/W	×	○	Page 363, Appendix 2 (21)
110(6E _H)	CH3	Adjustment sensitivity (dead band) setting	Adjustment sensitivity (dead band) setting*6	Adjustment sensitivity (dead band) setting	5	R/W	×	○	Page 363, Appendix 2 (22)
111(6F _H)	CH3	Control output cycle setting	Heating control output cycle setting*6	Control output cycle setting	30/300	R/W	×	○	Page 364, Appendix 2 (23)
112(70 _H)	CH3	Primary delay digital filter setting			0	R/W	×	○	Page 365, Appendix 2 (24)

Address (decimal (hexadecimal))	Target channel or current sensor (CT)	Setting contents			Default value *1	Read/ Write *2	Automatic setting *3	Non- volatile memory write availability *4	Reference
		Standard control	Heating- cooling control	Mix control					
113(71 _H)	CH3	Control response parameters	Control response parameters* ⁶	Control response parameters	0	R/W	×	○	Page 366, Appendix 2 (25)
114(72 _H)	CH3	AUTO/MAN mode shift	AUTO/MAN mode shift* ⁶	AUTO/MAN mode shift	0	R/W	×	○	Page 367, Appendix 2 (26)
115(73 _H)	CH3	MAN output setting	MAN output setting* ⁶	MAN output setting	0	R/W	×	○	Page 368, Appendix 2 (27)
116(74 _H)	CH3	Setting change rate limiter/Setting change rate limiter (temperature rise)* ¹⁰			0	R/W	×	○	Page 369, Appendix 2 (28)
117(75 _H)	CH3	AT bias	AT bias* ⁶	AT bias	0	R/W	○	○	Page 370, Appendix 2 (29)
118(76 _H)	CH3	Forward/reverse action setting	System area	Forward/reverse action setting	1	R/W	×	○	Page 371, Appendix 2 (30)
119(77 _H)	CH3	Upper limit setting limiter	Upper limit setting limiter* ⁶	Upper limit setting limiter	1300 (TT) 6000 (RT) * ⁵	R/W	○	○	Page 372, Appendix 2 (31)
120(78 _H)	CH3	Lower limit setting limiter	Lower limit setting limiter* ⁶	Lower limit setting limiter	0 (TT) -2000 (RT) * ⁵	R/W	○	○	
121(79 _H)	CH3	System area			—	—	—	—	—
122(7A _H)	CH3	Heater disconnection alert setting* ¹¹	Heater disconnection alert setting* ⁶ * ¹¹	Heater disconnection alert setting* ¹¹	0	R/W	×	○	Page 373, Appendix 2 (32)
123(7B _H)	CH3	Loop disconnection detection judgment time	System area	Loop disconnection detection judgment time	480	R/W	×	○	Page 374, Appendix 2 (33)
124(7C _H)	CH3	Loop disconnection detection dead band	System area	Loop disconnection detection dead band	0	R/W	○	○	Page 375, Appendix 2 (34)
125(7D _H)	CH3	Unused channel setting	Unused channel setting* ⁶	Unused channel setting	0	R/W	×	○	Page 376, Appendix 2 (35)
126(7E _H)	CH3	Memory of PID constants read instruction	Memory of PID constants read instruction* ⁶	Memory of PID constants read instruction	0	R/W	×	×	Page 377, Appendix 2 (36)
127(7F _H)	CH3	Automatic backup setting after auto tuning of PID constants	Automatic backup setting after auto tuning of PID constants* ⁶	Automatic backup setting after auto tuning of PID constants	0	R/W	×	×	Page 378, Appendix 2 (37)
128(80 _H)	CH4	Input range* ⁹			2(TT) 7(RT) * ⁵	R/W	×	○	Page 345, Appendix 2 (12)

Address (decimal (hexadecimal))	Target channel or current sensor (CT)	Setting contents			Default value *1	Read/ Write *2	Automatic setting *3	Non- volatile memory write availability *4	Reference
		Standard control	Heating- cooling control	Mix control					
129(81 _H)	CH4	Stop mode setting	Stop mode setting* ⁶	Stop mode setting	1	R/W	×	○	Page 353, Appendix 2 (13)
130(82 _H)	CH4	Set value (SV) setting	Set value (SV) setting* ⁶	Set value (SV) setting	0	R/W	○	○	Page 354, Appendix 2 (14)
131(83 _H)	CH4	Proportional band (P) setting	Heating proportional band (Ph) setting* ⁶	Proportional band (P) setting	30	R/W	×	○	Page 355, Appendix 2 (15)
132(84 _H)	CH4	Integral time (I) setting	Integral time (I) setting* ⁶	Integral time (I) setting	240	R/W	×	○	Page 357, Appendix 2 (16)
133(85 _H)	CH4	Derivative time (D) setting	Derivative time (D) setting* ⁶	Derivative time (D) setting	60	R/W	×	○	Page 357, Appendix 2 (17)
134(86 _H)	CH4	Alert set value 1	Alert set value 1* ⁶	Alert set value 1	0	R/W	○	○	Page 358, Appendix 2 (18)
135(87 _H)	CH4	Alert set value 2	Alert set value 2* ⁶	Alert set value 2	0	R/W	○	○	
136(88 _H)	CH4	Alert set value 3	Alert set value 3* ⁶	Alert set value 3	0	R/W	○	○	
137(89 _H)	CH4	Alert set value 4	Alert set value 4* ⁶	Alert set value 4	0	R/W	○	○	
138(8A _H)	CH4	Upper limit output limiter	Heating upper limit output limiter* ⁶	Upper limit output limiter	1000	R/W	×	○	Page 360, Appendix 2 (19)
139(8B _H)	CH4	Lower limit output limiter	System area	Lower limit output limiter	0	R/W	×	○	
140(8C _H)	CH4	Output variation limiter setting	Output variation limiter setting* ⁶	Output variation limiter setting	0	R/W	×	○	Page 362, Appendix 2 (20)
141(8D _H)	CH4	Sensor correction value setting			0	R/W	×	○	Page 363, Appendix 2 (21)
142(8E _H)	CH4	Adjustment sensitivity (dead band) setting	Adjustment sensitivity (dead band) setting* ⁶	Adjustment sensitivity (dead band) setting	5	R/W	×	○	Page 363, Appendix 2 (22)
143(8F _H)	CH4	Control output cycle setting	Heating control output cycle setting* ⁶	Control output cycle setting	30/300	R/W	×	○	Page 364, Appendix 2 (23)
144(90 _H)	CH4	Primary delay digital filter setting			0	R/W	×	○	Page 365, Appendix 2 (24)
145(91 _H)	CH4	Control response parameters	Control response parameters* ⁶	Control response parameters	0	R/W	×	○	Page 366, Appendix 2 (25)
146(92 _H)	CH4	AUTO/MAN mode shift	AUTO/MAN mode shift * ⁶	AUTO/MAN mode shift	0	R/W	×	○	Page 367, Appendix 2 (26)
147(93 _H)	CH4	MAN output setting	MAN output setting* ⁶	MAN output setting	0	R/W	×	○	Page 368, Appendix 2 (27)

Address (decimal (hexadecimal))	Target channel or current sensor (CT)	Setting contents			Default value *1	Read/ Write *2	Automatic setting *3	Non- volatile memory write availability *4	Reference
		Standard control	Heating- cooling control	Mix control					
148(94 _H)	CH4	Setting change rate limiter/Setting change rate limiter (temperature rise) *10			0	R/W	×	○	Page 369, Appendix 2 (28)
149(95 _H)	CH4	AT bias	AT bias *6	AT bias	0	R/W	○	○	Page 370, Appendix 2 (29)
150(96 _H)	CH4	Forward/reverse action setting	System area	Forward/revers e action setting	1	R/W	×	○	Page 371, Appendix 2 (30)
151(97 _H)	CH4	Upper limit setting limiter	Upper limit setting limiter*6	Upper limit setting limiter	1300 (TT) 6000 (RT) *5	R/W	○	○	Page 372, Appendix 2 (31)
152(98 _H)	CH4	Lower limit setting limiter	Lower limit setting limiter*6	Lower limit setting limiter	0 (TT) -2000 (RT) *5	R/W	○	○	
153(99 _H)	CH4	System area			—	—	—	—	—
154(9A _H)	CH4	Heater disconnection alert setting*11	Heater disconnection alert setting*6*11	Heater disconnection alert setting*11	0	R/W	×	○	Page 373, Appendix 2 (32)
155(9B _H)	CH4	Loop disconnection detection judgment time	System area	Loop disconnection detection judgment time	480	R/W	×	○	Page 374, Appendix 2 (33)
156(9C _H)	CH4	Loop disconnection detection dead band	System area	Loop disconnection detection dead band	0	R/W	○	○	Page 375, Appendix 2 (34)
157(9D _H)	CH4	Unused channel setting	Unused channel setting*6	Unused channel setting	0	R/W	×	○	Page 376, Appendix 2 (35)
158(9E _H)	CH4	Memory of PID constants read instruction	Memory of PID constants read instruction*6	Memory of PID constants read instruction	0	R/W	×	×	Page 377, Appendix 2 (36)
159(9F _H)	CH4	Automatic backup setting after auto tuning of PID constants	Automatic backup setting after auto tuning of PID constants*6	Automatic backup setting after auto tuning of PID constants	0	R/W	×	×	Page 378, Appendix 2 (37)
160(A0 _H) to 163(A3 _H)	—	System area			—	—	—	—	—
164(A4 _H)	All CHs	Alert dead band setting			5	R/W	×	○	Page 379, Appendix 2 (38)
165(A5 _H)	All CHs	Number of alert delay			0	R/W	×	○	Page 379, Appendix 2 (39)
166(A6 _H)	All CHs	Heater disconnection/output off-time current error detection delay count*11			3	R/W	×	○	Page 380, Appendix 2 (40)

Address (decimal (hexadecimal))	Target channel or current sensor (CT)	Setting contents			Default value *1	Read/ Write *2	Automatic setting *3	Non- volatile memory write availability *4	Reference
		Standard control	Heating- cooling control	Mix control					
167(A7 _H)	All CHs	Temperature rise completion range setting			1	R/W	×	○	Page 380, Appendix 2 (41)
168(A8 _H)	All CHs	Temperature rise completion soak time setting			0	R/W	×	○	Page 381, Appendix 2 (42)
169(A9 _H)	All CHs	PID continuation flag			0	R/W	×	○	Page 381, Appendix 2 (43)
170(AA _H)	All CHs	Heater disconnection correction function selection ^{*11}			0	R/W	×	○	Page 381, Appendix 2 (44)
171(AB _H) to 174(AE _H)	—	System area			—	—	—	—	—
175(AF _H)	All CHs	Transistor output monitor ON delay time setting			0	R/W	×	○	Page 382, Appendix 2 (45)
176(B0 _H)	All CHs	CT monitor method switching ^{*11}			0	R/W	×	○	Page 382, Appendix 2 (46)
177(B1 _H)	CH1	Manipulated value (MV) for output with another analog module	Manipulated value of heating (MVh) for output with another analog module	Manipulated value of heating (MVh) for output with another analog module	0	R	×	×	Page 383, Appendix 2 (47)
178(B2 _H)	CH2	Manipulated value (MV) for output with another analog module	Manipulated value of heating (MVh) for output with another analog module	Manipulated value of heating (MVh) for output with another analog module ^{*7}	0	R	×	×	
179(B3 _H)	CH3	Manipulated value (MV) for output with another analog module	Manipulated value of heating (MVh) for output with another analog module ^{*6}	Manipulated value (MV) for output with another analog module	0	R	×	×	
180(B4 _H)	CH4	Manipulated value (MV) for output with another analog module	Manipulated value of heating (MVh) for output with another analog module ^{*6}	Manipulated value (MV) for output with another analog module	0	R	×	×	
181(B5 _H)	All CHs	Resolution of the manipulated value for output with another analog module			0	R/W	×	○	Page 384, Appendix 2 (48)
182(B6 _H)	All CHs	Cold junction temperature compensation selection ^{*8}			0	R/W	×	○	Page 384, Appendix 2 (49)
183(B7 _H)	All CHs	Control switching monitor			0	R	×	×	Page 385, Appendix 2 (50)

Address (decimal (hexadecimal))	Target channel or current sensor (CT)	Setting contents			Default value *1	Read/ Write *2	Automatic setting *3	Non- volatile memory write availability *4	Reference
		Standard control	Heating- cooling control	Mix control					
184(B8 _H)	CH1	Auto tuning mode selection			0	R/W	x	○	Page 385, Appendix 2 (51)
185(B9 _H)	CH2	Auto tuning mode selection	Auto tuning mode selection	Auto tuning mode selection *7	0	R/W	x	○	
186(BA _H)	CH3	Auto tuning mode selection	Auto tuning mode selection *6	Auto tuning mode selection	0	R/W	x	○	
187(BB _H)	CH4	Auto tuning mode selection	Auto tuning mode selection *6	Auto tuning mode selection	0	R/W	x	○	
188(BC _H) to 191(BF _H)	—	System area			—	—	—	—	—
192(C0 _H)	CH1	Alert 1 mode setting *9			0	R/W	x	○	Page 386, Appendix 2 (52)
193(C1 _H)	CH1	Alert 2 mode setting *9			0	R/W	x	○	
194(C2 _H)	CH1	Alert 3 mode setting *9			0	R/W	x	○	
195(C3 _H)	CH1	Alert 4 mode setting *9			0	R/W	x	○	
196(C4 _H) to 207(CF _H)	—	System area			—	—	—	—	—
208(D0 _H)	CH2	Alert 1 mode setting *9	Alert 1 mode setting *9	Alert 1 mode setting *7*9	0	R/W	x	○	Page 386, Appendix 2 (52)
209(D1 _H)	CH2	Alert 2 mode setting *9	Alert 2 mode setting *9	Alert 2 mode setting *7*9	0	R/W	x	○	
210(D2 _H)	CH2	Alert 3 mode setting *9	Alert 3 mode setting *9	Alert 3 mode setting *7*9	0	R/W	x	○	
211(D3 _H)	CH2	Alert 4 mode setting *9	Alert 4 mode setting *9	Alert 4 mode setting *7*9	0	R/W	x	○	
212(D4 _H) to 223(DF _H)	—	System area			—	—	—	—	—
224(E0 _H)	CH3	Alert 1 mode setting *9	Alert 1 mode setting *6*9	Alert 1 mode setting *9	0	R/W	x	○	Page 386, Appendix 2 (52)
225(E1 _H)	CH3	Alert 2 mode setting *9	Alert 2 mode setting *6*9	Alert 2 mode setting *9	0	R/W	x	○	
226(E2 _H)	CH3	Alert 3 mode setting *9	Alert 3 mode setting *6*9	Alert 3 mode setting *9	0	R/W	x	○	
227(E3 _H)	CH3	Alert 4 mode setting *9	Alert 4 mode setting *6*9	Alert 4 mode setting *9	0	R/W	x	○	
228(E4 _H) to 239(EF _H)	—	System area			—	—	—	—	—

Address (decimal (hexadecimal))	Target channel or current sensor (CT)	Setting contents			Default value *1	Read/ Write *2	Automatic setting *3	Non- volatile memory write availability *4	Reference
		Standard control	Heating- cooling control	Mix control					
240(F0 _H)	CH4	Alert 1 mode setting*9	Alert 1 mode setting*6*9	Alert 1 mode setting*9	0	R/W	×	○	Page 386, Appendix 2 (52)
241(F1 _H)	CH4	Alert 2 mode setting*9	Alert 2 mode setting*6*9	Alert 2 mode setting*9	0	R/W	×	○	
242(F2 _H)	CH4	Alert 3 mode setting*9	Alert 3 mode setting*6*9	Alert 3 mode setting*9	0	R/W	×	○	
243(F3 _H)	CH4	Alert 4 mode setting*9	Alert 4 mode setting*6*9	Alert 4 mode setting*9	0	R/W	×	○	
244(F4 _H) to 255(FF _H)	—	System area			—	—	—	—	—
256(100 _H)	CT1	Heater current measurement value*11			0	R	×	×	Page 390, Appendix 2 (58)
257(101 _H)	CT2	Heater current measurement value*11							
258(102 _H)	CT3	Heater current measurement value*11							
259(103 _H)	CT4	Heater current measurement value*11							
260(104 _H)	CT5	Heater current measurement value*11							
261(105 _H)	CT6	Heater current measurement value*11							
262(106 _H)	CT7	Heater current measurement value*11							
263(107 _H)	CT8	Heater current measurement value*11							
264(108 _H)	CT1	CT input channel assignment setting*11			0	R/W	×	○	Page 391, Appendix 2 (59)
265(109 _H)	CT2	CT input channel assignment setting*11							
266(10A _H)	CT3	CT input channel assignment setting*11							
267(10B _H)	CT4	CT input channel assignment setting*11							
268(10C _H)	CT5	CT input channel assignment setting*11							
269(10D _H)	CT6	CT input channel assignment setting*11							
270(10E _H)	CT7	CT input channel assignment setting*11							
271(10F _H)	CT8	CT input channel assignment setting*11							
272(110 _H)	CT1	CT selection*9*11			0	R/W	×	○	Page 392, Appendix 2 (60)
273(111 _H)	CT2	CT selection*9*11							
274(112 _H)	CT3	CT selection*9*11							
275(113 _H)	CT4	CT selection*9*11							
276(114 _H)	CT5	CT selection*9*11							
277(115 _H)	CT6	CT selection*9*11							
278(116 _H)	CT7	CT selection*9*11							
279(117 _H)	CT8	CT selection*9*11							
280(118 _H)	CT1	Reference heater current value*11			0	R/W	×	○	Page 393, Appendix 2 (61)
281(119 _H)	CT2	Reference heater current value*11							
282(11A _H)	CT3	Reference heater current value*11							
283(11B _H)	CT4	Reference heater current value*11							
284(11C _H)	CT5	Reference heater current value*11							
285(11D _H)	CT6	Reference heater current value*11							
286(11E _H)	CT7	Reference heater current value*11							
287(11F _H)	CT8	Reference heater current value*11							

Address (decimal (hexadecimal))	Target channel or current sensor (CT)	Setting contents			Default value *1	Read/ Write *2	Automatic setting *3	Non- volatile memory write availability *4	Reference
		Standard control	Heating- cooling control	Mix control					
288(120 _H)	CT1	CT ratio setting ^{*11}			800	R/W	×	○	Page 393, Appendix 2 (62)
289(121 _H)	CT2	CT ratio setting ^{*11}							
290(122 _H)	CT3	CT ratio setting ^{*11}							
291(123 _H)	CT4	CT ratio setting ^{*11}							
292(124 _H)	CT5	CT ratio setting ^{*11}							
293(125 _H)	CT6	CT ratio setting ^{*11}							
294(126 _H)	CT7	CT ratio setting ^{*11}							
295(127 _H)	CT8	CT ratio setting ^{*11}							
296(128 _H) to 543(21F _H)	—	System area			—	—	—	—	—
544(220 _H)	CH1	2-point sensor compensation offset value (measured value) ^{*9}			0	R/W	○	○	Page 394, Appendix 2 (63)
545(221 _H)	CH1	2-point sensor compensation offset value (compensation value) ^{*9}			0	R/W	○	○	Page 394, Appendix 2 (64)
546(222 _H)	CH1	2-point sensor compensation gain value (measured value) ^{*9}			0	R/W	○	○	Page 395, Appendix 2 (65)
547(223 _H)	CH1	2-point sensor compensation gain value (compensation value) ^{*9}			0	R/W	○	○	Page 395, Appendix 2 (66)
548(224 _H)	CH1	2-point sensor compensation offset latch request ^{*9}			0	R/W	×	×	Page 396, Appendix 2 (67)
549(225 _H)	CH1	2-point sensor compensation offset latch completion			0	R	×	×	Page 396, Appendix 2 (68)
550(226 _H)	CH1	2-point sensor compensation gain latch request ^{*9}			0	R/W	×	×	Page 397, Appendix 2 (69)
551(227 _H)	CH1	2-point sensor compensation gain latch completion			0	R	×	×	Page 397, Appendix 2 (70)
552(228 _H) to 563(233 _H)	—	System area			—	—	—	—	—
564(234 _H)	CH1	Setting change rate limiter (temperature drop) ^{*12}			0	R/W	×	○	Page 369, Appendix 2 (28)
565(235 _H) to 572(23C _H)	—	System area			—	—	—	—	—
573(23D _H)	CH1	AT simultaneous temperature rise parameter calculation flag	System area	System area	0	R	×	×	Page 398, Appendix 2 (71)
574(23E _H)	CH1	Self-tuning setting	System area	System area	0	R/W	×	○	Page 399, Appendix 2 (72)

Address (decimal (hexadecimal))	Target channel or current sensor (CT)	Setting contents			Default value *1	Read/ Write *2	Automatic setting *3	Non- volatile memory write availability *4	Reference
		Standard control	Heating- cooling control	Mix control					
575(23F _H)	CH1	Self-tuning flag	System area	System area	0	R	×	×	Page 400, Appendix 2 (73)
576(240 _H)	CH2	2-point sensor compensation offset value (measured value) ^{*9}			0	R/W	○	○	Page 394, Appendix 2 (63)
577(241 _H)	CH2	2-point sensor compensation offset value (compensation value) ^{*9}			0	R/W	○	○	Page 394, Appendix 2 (64)
578(242 _H)	CH2	2-point sensor compensation gain value (measured value) ^{*9}			0	R/W	○	○	Page 395, Appendix 2 (65)
579(243 _H)	CH2	2-point sensor compensation gain value (compensation value) ^{*9}			0	R/W	○	○	Page 395, Appendix 2 (66)
580(244 _H)	CH2	2-point sensor compensation offset latch request ^{*9}			0	R/W	×	×	Page 396, Appendix 2 (67)
581(245 _H)	CH2	2-point sensor compensation offset latch completion			0	R	×	×	Page 396, Appendix 2 (68)
582(246 _H)	CH2	2-point sensor compensation gain latch request ^{*9}			0	R/W	×	×	Page 397, Appendix 2 (69)
583(247 _H)	CH2	2-point sensor compensation gain latch completion			0	R	×	×	Page 397, Appendix 2 (70)
584(248 _H) to 595(253 _H)	—	System area			—	—	—	—	—
596(254 _H)	CH2	Setting change rate limiter (temperature drop) ^{*12}			0	R/W	×	○	Page 369, Appendix 2 (28)
597(255 _H) to 604(25C _H)	—	System area			—	—	—	—	—
605(25D _H)	CH2	AT simultaneous temperature rise parameter calculation flag	System area	System area	0	R	×	×	Page 398, Appendix 2 (71)
606(25E _H)	CH2	Self-tuning setting	System area	System area	0	R/W	×	○	Page 399, Appendix 2 (72)
607(25F _H)	CH2	Self-tuning flag	System area	System area	0	R	×	×	Page 400, Appendix 2 (73)
608(260 _H)	CH3	2-point sensor compensation offset value (measured value) ^{*9}			0	R/W	○	○	Page 394, Appendix 2 (63)
609(261 _H)	CH3	2-point sensor compensation offset value (compensation value) ^{*9}			0	R/W	○	○	Page 394, Appendix 2 (64)
610(262 _H)	CH3	2-point sensor compensation gain value (measured value) ^{*9}			0	R/W	○	○	Page 395, Appendix 2 (65)

Address (decimal (hexadecimal))	Target channel or current sensor (CT)	Setting contents			Default value *1	Read/ Write *2	Automatic setting *3	Non- volatile memory write availability *4	Reference
		Standard control	Heating- cooling control	Mix control					
611(263 _H)	CH3	2-point sensor compensation gain value (compensation value) ^{*9}			0	R/W	○	○	Page 395, Appendix 2 (66)
612(264 _H)	CH3	2-point sensor compensation offset latch request ^{*9}			0	R/W	×	×	Page 396, Appendix 2 (67)
613(265 _H)	CH3	2-point sensor compensation offset latch completion			0	R	×	×	Page 396, Appendix 2 (68)
614(266 _H)	CH3	2-point sensor compensation gain latch request ^{*9}			0	R/W	×	×	Page 397, Appendix 2 (69)
615(267 _H)	CH3	2-point sensor compensation gain latch completion			0	R	×	×	Page 397, Appendix 2 (70)
616(268 _H) to 627(273 _H)	—	System area			—	—	—	—	—
628(274 _H)	CH3	Setting change rate limiter (temperature drop) ^{*12}			0	R/W	×	○	Page 369, Appendix 2 (28)
629(275 _H) to 636(27C _H)	—	System area			—	—	—	—	—
637(27D _H)	CH3	AT simultaneous temperature rise parameter calculation flag	System area	AT simultaneous temperature rise parameter calculation flag	0	R	×	×	Page 398, Appendix 2 (71)
638(27E _H)	CH3	Self-tuning setting	System area	Self-tuning setting	0	R/W	×	○	Page 399, Appendix 2 (72)
639(27F _H)	CH3	Self-tuning flag	System area	Self-tuning flag	0	R	×	×	Page 400, Appendix 2 (73)
640(280 _H)	CH4	2-point sensor compensation offset value (measured value) ^{*9}			0	R/W	○	○	Page 394, Appendix 2 (63)
641(281 _H)	CH4	2-point sensor compensation offset value (compensation value) ^{*9}			0	R/W	○	○	Page 394, Appendix 2 (64)
642(282 _H)	CH4	2-point sensor compensation gain value (measured value) ^{*9}			0	R/W	○	○	Page 395, Appendix 2 (65)
643(283 _H)	CH4	2-point sensor compensation gain value (compensation value) ^{*9}			0	R/W	○	○	Page 395, Appendix 2 (66)
644(284 _H)	CH4	2-point sensor compensation offset latch request ^{*9}			0	R/W	×	×	Page 396, Appendix 2 (67)
645(285 _H)	CH4	2-point sensor compensation offset latch completion			0	R	×	×	Page 396, Appendix 2 (68)

Address (decimal (hexadecimal))	Target channel or current sensor (CT)	Setting contents			Default value *1	Read/ Write *2	Automatic setting *3	Non- volatile memory write availability *4	Reference
		Standard control	Heating- cooling control	Mix control					
646(286 _H)	CH4	2-point sensor compensation gain latch request ^{*9}			0	R/W	x	x	Page 397, Appendix 2 (69)
647(287 _H)	CH4	2-point sensor compensation gain latch completion			0	R	x	x	Page 397, Appendix 2 (70)
648(288 _H) to 659(293 _H)	—	System area			—	—	—	—	—
660(294 _H)	CH4	Setting change rate limiter (temperature drop) ^{*12}			0	R/W	x	○	Page 369, Appendix 2 (28)
661(295 _H) to 668(29C _H)	—	System area			—	—	—	—	—
669(29D _H)	CH4	AT simultaneous temperature rise parameter calculation flag	System area	AT simultaneous temperature rise parameter calculation flag	0	R	x	x	Page 398, Appendix 2 (71)
670(29E _H)	CH4	Self-tuning setting	System area	Self-tuning setting	0	R/W	x	○	Page 399, Appendix 2 (72)
671(29F _H)	CH4	Self-tuning flag	System area	Self-tuning flag	0	R	x	x	Page 400, Appendix 2 (73)
672(2A0 _H) to 688(2B0 _H)	—	System area			—	—	—	—	—
689(2B1 _H)	CH1	Temperature process value (PV) for input with another analog module			0	R/W	x	x	Page 402, Appendix 2 (74)
690(2B2 _H)	CH2	Temperature process value (PV) for input with another analog module	Temperature process value (PV) for input with another analog module	Temperature process value (PV) for input with another analog module *7	0	R/W	x	x	
691(2B3 _H)	CH3	Temperature process value (PV) for input with another analog module	Temperature process value (PV) for input with another analog module ^{*6}	Temperature process value (PV) for input with another analog module	0	R/W	x	x	
692(2B4 _H)	CH4	Temperature process value (PV) for input with another analog module	Temperature process value (PV) for input with another analog module ^{*6}	Temperature process value (PV) for input with another analog module	0	R/W	x	x	
693(2B5 _H)	—	System area			—	—	—	—	
694(2B6 _H)	—	System area			—	—	—	—	—

Address (decimal (hexadecimal))	Target channel or current sensor (CT)	Setting contents			Default value *1	Read/ Write *2	Automatic setting *3	Non- volatile memory write availability *4	Reference
		Standard control	Heating- cooling control	Mix control					
695(2B7 _H)	CH2	System area	System area	Temperature conversion setting *14	0	R/W	×	○	Page 403, Appendix 2 (76)
696(2B8 _H)	CH3	System area	Temperature conversion setting *13	System area	0	R/W	×	○	
697(2B9 _H)	CH4	System area	Temperature conversion setting *13	System area	0	R/W	×	○	
698(2BA _H) to 703(2BF _H)	—	System area			—	—	—	—	—
704(2C0 _H)	CH1	System area	Manipulated value for cooling (MVc)	Manipulated value for cooling (MVc)	0	R	×	×	Page 339, Appendix 2 (5)
705(2C1 _H)	CH2	System area	Manipulated value for cooling (MVc)	Manipulated value for cooling (MVc)*7	0	R	×	×	
706(2C2 _H)	CH3	System area	Manipulated value for cooling (MVc)*6	System area	0	R	×	×	
707(2C3 _H)	CH4	System area	Manipulated value for cooling (MVc)*6	System area	0	R	×	×	
708(2C4 _H)	CH1	System area	Manipulated value of cooling (MVc) for output with another analog module	Manipulated value of cooling (MVc) for output with another analog module	0	R	×	×	Page 383, Appendix 2 (47)
709(2C5 _H)	CH2	System area	Manipulated value of cooling (MVc) for output with another analog module	Manipulated value of cooling (MVc) for output with another analog module*7	0	R	×	×	
710(2C6 _H)	CH3	System area	Manipulated value of cooling (MVc) for output with another analog module*6	System area	0	R	×	×	
711(2C7 _H)	CH4	System area	Manipulated value of cooling (MVc) for output with another analog module*6	System area	0	R	×	×	





Address (decimal (hexadecimal))	Target channel or current sensor (CT)	Setting contents			Default value *1	Read/ Write *2	Automatic setting *3	Non- volatile memory write availability *4	Reference
		Standard control	Heating- cooling control	Mix control					
712(2C8 _H)	CH1	System area	Cooling transistor output flag	Cooling transistor output flag	0	R	x	x	Page 341, Appendix 2 (7)
713(2C9 _H)	CH2	System area	Cooling transistor output flag	Cooling transistor output flag *7	0	R	x	x	
714(2CA _H)	CH3	System area	Cooling transistor output flag *6	System area	0	R	x	x	
715(2CB _H)	CH4	System area	Cooling transistor output flag *6	System area	0	R	x	x	
716(2CC _H) to 718(2CE _H)	—	System area			—	—	—	—	—
719(2CF _H)	All CHs	System area	Cooling method setting *9	Cooling method setting *9	0	R/W	x	○	Page 404, Appendix 2 (77)
720(2D0 _H)	CH1	System area	Cooling proportional band (Pc) setting	Cooling proportional band (Pc) setting	30	R/W	x	○	Page 355, Appendix 2 (15)
721(2D1 _H)	CH1	System area	Cooling upper limit output limiter	Cooling upper limit output limiter	1000	R/W	x	○	Page 360, Appendix 2 (19)
722(2D2 _H)	CH1	System area	Cooling control output cycle setting	Cooling control output cycle setting	30/300	R/W	x	○	Page 364, Appendix 2 (23)
723(2D3 _H)	CH1	System area	Overlap/dead band setting	Overlap/dead band setting	0	R/W	x	○	Page 404, Appendix 2 (78)
724(2D4 _H)	CH1	Manual reset amount setting			0	R/W	x	○	Page 405, Appendix 2 (79)
725(2D5 _H)	CH1	Process value (PV) scaling function enable/disable setting*9			0	R/W	x	○	Page 405, Appendix 2 (80)
726(2D6 _H)	CH1	Process value (PV) scaling lower limit value*9			0	R/W	x	○	Page 406, Appendix 2 (81)
727(2D7 _H)	CH1	Process value (PV) scaling upper limit value*9			0	R/W	x	○	
728(2D8 _H)	CH1	Process value (PV) scaling value			0	R	x	x	Page 406, Appendix 2 (82)
729(2D9 _H)	CH1	Derivative action selection*9			0	R/W	x	○	Page 407, Appendix 2 (83)
730(2DA _H)	CH1	Simultaneous temperature rise group setting*9	System area	System area	0	R/W	x	○	Page 407, Appendix 2 (84)
731(2DB _H)	CH1	Simultaneous temperature rise gradient data	System area	System area	0	R/W	○	○	Page 408, Appendix 2 (85)

Address (decimal (hexadecimal))	Target channel or current sensor (CT)	Setting contents			Default value *1	Read/ Write *2	Automatic setting *3	Non- volatile memory write availability *4	Reference
		Standard control	Heating- cooling control	Mix control					
732(2DC _H)	CH1	Simultaneous temperature rise dead time	System area	System area	0	R/W	○	○	Page 408, Appendix 2 (86)
733(2DD _H)	CH1	Simultaneous temperature rise AT mode selection	System area	System area	0	R/W	×	○	Page 409, Appendix 2 (87)
734(2DE _H)	CH1	Simultaneous temperature rise status	System area	System area	0	R	×	×	Page 410, Appendix 2 (88)
735(2DF _H)	CH1	Setting change rate limiter unit time setting ^{*9}			0	R/W	×	○	Page 411, Appendix 2 (89)
736(2E0 _H)	CH2	System area	Cooling proportional band (Pc) setting	Cooling proportional band (Pc) setting ^{*7}	30	R/W	×	○	Page 355, Appendix 2 (15)
737(2E1 _H)	CH2	System area	Cooling upper limit output limiter	Cooling upper limit output limiter ^{*7}	1000	R/W	×	○	Page 360, Appendix 2 (19)
738(2E2 _H)	CH2	System area	Cooling control output cycle setting	Cooling control output cycle setting ^{*7}	30/300	R/W	×	○	Page 364, Appendix 2 (23)
739(2E3 _H)	CH2	System area	Overlap/dead band setting	Overlap/dead band setting ^{*7}	0	R/W	×	○	Page 404, Appendix 2 (78)
740(2E4 _H)	CH2	Manual reset amount setting	Manual reset amount setting	Manual reset amount setting ^{*7}	0	R/W	×	○	Page 405, Appendix 2 (79)
741(2E5 _H)	CH2	Process value (PV) scaling function enable/disable setting ^{*9}	Process value (PV) scaling function enable/disable setting ^{*9}	Process value (PV) scaling function enable/disable setting ^{*7*9}	0	R/W	×	○	Page 405, Appendix 2 (80)
742(2E6 _H)	CH2	Process value (PV) scaling lower limit value ^{*9}	Process value (PV) scaling lower limit value ^{*9}	Process value (PV) scaling lower limit value ^{*7*9}	0	R/W	×	○	Page 406, Appendix 2 (81)
743(2E7 _H)	CH2	Process value (PV) scaling upper limit value ^{*9}	Process value (PV) scaling upper limit value ^{*9}	Process value (PV) scaling upper limit value ^{*7*9}	0	R/W	×	○	
744(2E8 _H)	CH2	Process value (PV) scaling value	Process value (PV) scaling value	Process value (PV) scaling value ^{*7}	0	R	×	×	Page 406, Appendix 2 (82)
745(2E9 _H)	CH2	Derivative action selection ^{*9}	Derivative action selection ^{*9}	Derivative action selection ^{*7*9}	0	R/W	×	○	Page 407, Appendix 2 (83)
746(2EA _H)	CH2	Simultaneous temperature rise group setting ^{*9}	System area	System area	0	R/W	×	○	Page 407, Appendix 2 (84)
747(2EB _H)	CH2	Simultaneous temperature rise gradient data	System area	System area	0	R/W	○	○	Page 408, Appendix 2 (85)

Address (decimal (hexadecimal))	Target channel or current sensor (CT)	Setting contents			Default value *1	Read/ Write *2	Automatic setting *3	Non- volatile memory write availability *4	Reference
		Standard control	Heating- cooling control	Mix control					
748(2EC _H)	CH2	Simultaneous temperature rise dead time	System area	System area	0	R/W	○	○	Page 408, Appendix 2 (86)
749(2ED _H)	CH2	Simultaneous temperature rise AT mode selection	System area	System area	0	R/W	×	○	Page 409, Appendix 2 (87)
750(2EE _H)	CH2	Simultaneous temperature rise status	System area	System area	0	R	×	×	Page 410, Appendix 2 (88)
751(2EF _H)	CH2	Setting change rate limiter unit time setting ^{*9}	Setting change rate limiter unit time setting ^{*9}	Setting change rate limiter unit time setting ^{*7*9}	0	R/W	×	○	Page 411, Appendix 2 (89)
752(2F0 _H)	CH3	System area	Cooling proportional band (Pc) setting ^{*6}	System area	30	R/W	×	○	Page 355, Appendix 2 (15)
753(2F1 _H)	CH3	System area	Cooling upper limit output limiter ^{*6}	System area	1000	R/W	×	○	Page 360, Appendix 2 (19)
754(2F2 _H)	CH3	System area	Cooling control output cycle setting ^{*6}	System area	30/300	R/W	×	○	Page 364, Appendix 2 (23)
755(2F3 _H)	CH3	System area	Overlap/dead band setting ^{*6}	System area	0	R/W	×	○	Page 404, Appendix 2 (78)
756(2F4 _H)	CH3	Manual reset amount setting	Manual reset amount setting ^{*6}	Manual reset amount setting	0	R/W	×	○	Page 405, Appendix 2 (79)
757(2F5 _H)	CH3	Process value (PV) scaling function enable/disable setting ^{*9}	Process value (PV) scaling function enable/disable setting ^{*6*9}	Process value (PV) scaling function enable/disable setting ^{*9}	0	R/W	×	○	Page 405, Appendix 2 (80)
758(2F6 _H)	CH3	Process value (PV) scaling lower limit value ^{*9}	Process value (PV) scaling lower limit value ^{*6*9}	Process value (PV) scaling lower limit value ^{*9}	0	R/W	×	○	Page 406, Appendix 2 (81)
759(2F7 _H)	CH3	Process value (PV) scaling upper limit value ^{*9}	Process value (PV) scaling upper limit value ^{*6*9}	Process value (PV) scaling upper limit value ^{*9}	0	R/W	×	○	
760(2F8 _H)	CH3	Process value (PV) scaling value	Process value (PV) scaling value ^{*6}	Process value (PV) scaling value	0	R	×	×	Page 406, Appendix 2 (82)
761(2F9 _H)	CH3	Derivative action selection ^{*9}	Derivative action selection ^{*6*9}	Derivative action selection ^{*9}	0	R/W	×	○	Page 407, Appendix 2 (83)
762(2FA _H)	CH3	Simultaneous temperature rise group setting ^{*9}	System area	Simultaneous temperature rise group setting ^{*9}	0	R/W	×	○	Page 407, Appendix 2 (84)

Address (decimal (hexadecimal))	Target channel or current sensor (CT)	Setting contents			Default value *1	Read/ Write *2	Automatic setting *3	Non- volatile memory write availability *4	Reference
		Standard control	Heating- cooling control	Mix control					
763(2FB _H)	CH3	Simultaneous temperature rise gradient data	System area	Simultaneous temperature rise gradient data	0	R/W	○	○	Page 408, Appendix 2 (85)
764(2FC _H)	CH3	Simultaneous temperature rise dead time	System area	Simultaneous temperature rise dead time	0	R/W	○	○	Page 408, Appendix 2 (86)
765(2FD _H)	CH3	Simultaneous temperature rise AT mode selection	System area	Simultaneous temperature rise AT mode selection	0	R/W	×	○	Page 409, Appendix 2 (87)
766(2FE _H)	CH3	Simultaneous temperature rise status	System area	Simultaneous temperature rise status	0	R	×	×	Page 410, Appendix 2 (88)
767(2FF _H)	CH3	Setting change rate limiter unit time setting ^{*9}	Setting change rate limiter unit time setting ^{*6*9}	Setting change rate limiter unit time setting ^{*9}	0	R/W	×	○	Page 411, Appendix 2 (89)
768(300 _H)	CH4	System area	Cooling proportional band (Pc) setting ^{*6}	System area	30	R/W	×	○	Page 355, Appendix 2 (15)
769(301 _H)	CH4	System area	Cooling upper limit output limiter ^{*6}	System area	1000	R/W	×	○	Page 360, Appendix 2 (19)
770(302 _H)	CH4	System area	Cooling control output cycle setting ^{*6}	System area	30/300	R/W	×	○	Page 364, Appendix 2 (23)
771(303 _H)	CH4	System area	Overlap/dead band setting ^{*6}	System area	0	R/W	×	○	Page 404, Appendix 2 (78)
772(304 _H)	CH4	Manual reset amount setting	Manual reset amount setting ^{*6}	Manual reset amount setting	0	R/W	×	○	Page 405, Appendix 2 (79)
773(305 _H)	CH4	Process value (PV) scaling function enable/disable setting ^{*9}	Process value (PV) scaling function enable/disable setting ^{*6*9}	Process value (PV) scaling function enable/disable setting ^{*9}	0	R/W	×	○	Page 405, Appendix 2 (80)
774(306 _H)	CH4	Process value (PV) scaling lower limit value ^{*9}	Process value (PV) scaling lower limit value ^{*6*9}	Process value (PV) scaling lower limit value ^{*9}	0	R/W	×	○	Page 406, Appendix 2 (81)
775(307 _H)	CH4	Process value (PV) scaling upper limit value ^{*9}	Process value (PV) scaling upper limit value ^{*6*9}	Process value (PV) scaling upper limit value ^{*9}	0	R/W	×	○	
776(308 _H)	CH4	Process value (PV) scaling value	Process value (PV) scaling value ^{*6}	Process value (PV) scaling value	0	R	×	×	Page 406, Appendix 2 (82)
777(309 _H)	CH4	Derivative action selection ^{*9}	Derivative action selection ^{*6*9}	Derivative action selection ^{*9}	0	R/W	×	○	Page 407, Appendix 2 (83)

Address (decimal (hexadecimal))	Target channel or current sensor (CT)	Setting contents			Default value *1	Read/ Write *2	Automatic setting *3	Non- volatile memory write availability *4	Reference
		Standard control	Heating- cooling control	Mix control					
778(30A _H)	CH4	Simultaneous temperature rise group setting ^{*9}	System area	Simultaneous temperature rise group setting ^{*9}	0	R/W	x	○	Page 407, Appendix 2 (84)
779(30B _H)	CH4	Simultaneous temperature rise gradient data	System area	Simultaneous temperature rise gradient data	0	R/W	○	○	Page 408, Appendix 2 (85)
780(30C _H)	CH4	Simultaneous temperature rise dead time	System area	Simultaneous temperature rise dead time	0	R/W	○	○	Page 408, Appendix 2 (86)
781(30D _H)	CH4	Simultaneous temperature rise AT mode selection	System area	Simultaneous temperature rise AT mode selection	0	R/W	x	○	Page 409, Appendix 2 (87)
782(30E _H)	CH4	Simultaneous temperature rise status	System area	Simultaneous temperature rise status	0	R	x	x	Page 410, Appendix 2 (88)
783(30F _H)	CH4	Setting change rate limiter unit time setting ^{*9}	Setting change rate limiter unit time setting ^{*6*9}	Setting change rate limiter unit time setting ^{*9}	0	R/W	x	○	Page 411, Appendix 2 (89)
784(310 _H)	All CHs	Peak current suppression control group setting ^{*9}	System area	System area	0	R/W	x	○	Page 412, Appendix 2 (90)
785(311 _H)	All CHs	Sensor compensation function selection ^{*9}			0	R/W	x	○	Page 413, Appendix 2 (91)
786(312 _H)	All CHs	Temperature conversion completion flag			0	R	x	x	Page 413, Appendix 2 (92)
787(313 _H)	All CHs	Function extension bit monitor			0	R	x	x	Page 414, Appendix 2 (93)
788(314 _H)	All CHs	Sampling cycle monitor			0	R	x	x	Page 414, Appendix 2 (94)
789(315 _H) to 1278(4FE _H)	—	System area			—	—	—	—	—
1279(4FF _H) to 4095(FFF _H)	Buffer memory for error history (👉 Page 76, Section 3.5 (2))								
4096(1000 _H) to 53247(CFFF _H)	—	System area			—	—	—	—	—

- *1 This default value is set after the module is turned off and on or after the CPU module is reset and the reset is cancelled.
- *2 This column indicates whether data can be read from or written to the buffer memory area through sequence programs.
R: Reading enabled
W: Writing enabled
- *3 This column indicates whether the setting in the buffer memory area is automatically changed when the input range is changed. Enable/disable of automatic change can be set on Switch Setting. For details, refer to  Page 234, Section 8.3.3.
- *4 Whether writing to the non-volatile memory by turning off and on Set value backup instruction (Yn8) is enabled in this column. For details, refer to  Page 235, Section 8.3.4.
- *5 (TT) indicates the L60TCTT4 and L60TCTT4BW. (RT) indicates the L60TCRT4 and L60TCRT4BW.
- *6 Available only when the heating-cooling control (expanded mode) is set on Switch Setting. With other models, this area is handled as a system area.
- *7 Available only when the mix control (expanded mode) is set on Switch Setting. With other models, this area is handled as a system area.
- *8 Available only when the L60TCTT4 or L60TCTT4BW is used. With other models, this area is handled as a system area.
- *9 Available only in the setting mode. To enable the setting contents, turn off, on, and on Setting change instruction (YnB) when Setting/operation mode instruction (Yn1) is off (during setting mode). Note that a write data error (error code: □□□3H) occurs if the setting is changed during the operation mode.
- *10 By using the setting change rate limiter, whether to set temperature rise/temperature drop in a batch or individually can be selected on Switch Setting. In the batch setting, the target of setting change rate limiter is only this area. In the individual setting, this area is the setting target for the temperature rise. For details, refer to  Page 155, Section 8.2.10.
- *11 Available only when the L60TCTT4BW or L60TCRT4BW is used. With other models, this area is handled as a system area.
- *12 By using the setting change rate limiter, whether to set temperature rise/temperature drop in a batch or individually can be selected on Switch Setting. In the batch setting, this area is handled as a system area. In the individual setting, this area is the setting target for the temperature drop. For details, refer to  Page 155, Section 8.2.10.
- *13 Available only when the heating-cooling control (normal mode) is set on Switch Setting. With other models, this area is handled as a system area.
- *14 Available only when the mix control (normal mode) is set on Switch Setting. With other models, this area is handled as a system area.

(2) Buffer memory address for error history

Address (decimal (hexadecimal))	Target channel	Setting contents		Default value *1	Read/ Write *2	Automatic setting *3	Non- volatile memory write availability *4	Reference	
1279(4FF _H)	All CHs	Latest address of error history		0	R	x	x	Page 415, Appendix 2 (95)	
1280(500 _H)	All CHs	History 1	Error code		0	R	x	x	
1281(501 _H)			Error occurrence time	Upper 2 digits of year					Lower 2 digits of year
1282(502 _H)				Month					Day
1283(503 _H)				Hour					Minute
1284(504 _H)				Second					Day of the week
1285(505 _H) to 1287(507 _H)	—	System area		—	—	—	—	—	
1288(508 _H) to 1292(50C _H)	All CHs	History 2	Error code, error occurrence time (Data structure is the same as that of History 1.)		0	R	x	x	Page 415, Appendix 2 (96)
1293(50D _H) to 1295(50F _H)	—	System area		—	—	—	—	—	
1296(510 _H) to 1300(514 _H)	All CHs	History 3	Error code, error occurrence time (Data structure is the same as that of History 1.)		0	R	x	x	Page 415, Appendix 2 (96)
1301(515 _H) to 1303(517 _H)	—	System area		—	—	—	—	—	
1304(518 _H) to 1308(51C _H)	All CHs	History 4	Error code, error occurrence time (Data structure is the same as that of History 1.)		0	R	x	x	Page 415, Appendix 2 (96)
1309(51D _H) to 1311(51F _H)	—	System area		—	—	—	—	—	
1312(520 _H) to 1316(524 _H)	All CHs	History 5	Error code, error occurrence time (Data structure is the same as that of History 1.)		0	R	x	x	Page 415, Appendix 2 (96)
1317(525 _H) to 1319(527 _H)	—	System area		—	—	—	—	—	
1320(528 _H) to 1324(52C _H)	All CHs	History 6	Error code, error occurrence time (Data structure is the same as that of History 1.)		0	R	x	x	Page 415, Appendix 2 (96)

Address (decimal (hexadecimal))	Target channel	Setting contents		Default value *1	Read/ Write *2	Automatic setting *3	Non- volatile memory write availability *4	Reference
1325(52D _H) to 1327(52F _H)	—	System area		—	—	—	—	—
1328(530 _H) to 1332(534 _H)	All CHs	History 7	Error code, error occurrence time (Data structure is the same as that of History 1.)	0	R	×	×	Page 415, Appendix 2 (96)
1333(535 _H) to 1335(537 _H)	—	System area		—	—	—	—	—
1336(538 _H) to 1340(53C _H)	All CHs	History 8	Error code, error occurrence time (Data structure is the same as that of History 1.)	0	R	×	×	Page 415, Appendix 2 (96)
1341(53D _H) to 1343(53F _H)	—	System area		—	—	—	—	—
1344(540 _H) to 1348(544 _H)	All CHs	History 9	Error code, error occurrence time (Data structure is the same as that of History 1.)	0	R	×	×	Page 415, Appendix 2 (96)
1349(545 _H) to 1351(547 _H)	—	System area		—	—	—	—	—
1352(548 _H) to 1356(54C _H)	All CHs	History 10	Error code, error occurrence time (Data structure is the same as that of History 1.)	0	R	×	×	Page 415, Appendix 2 (96)
1357(54D _H) to 1359(54F _H)	—	System area		—	—	—	—	—
1360(550 _H) to 1364(554 _H)	All CHs	History 11	Error code, error occurrence time (Data structure is the same as that of History 1.)	0	R	×	×	Page 415, Appendix 2 (96)
1365(555 _H) to 1367(557 _H)	—	System area		—	—	—	—	—
1368(558 _H) to 1372(55C _H)	All CHs	History 12	Error code, error occurrence time (Data structure is the same as that of History 1.)	0	R	×	×	Page 415, Appendix 2 (96)
1373(55D _H) to 1375(55F _H)	—	System area		—	—	—	—	—
1376(560 _H) to 1380(564 _H)	All CHs	History 13	Error code, error occurrence time (Data structure is the same as that of History 1.)	0	R	×	×	Page 415, Appendix 2 (96)

Address (decimal (hexadecimal))	Target channel	Setting contents		Default value *1	Read/ Write *2	Automatic setting *3	Non- volatile memory write availability *4	Reference
1381(565 _H) to 1383(567 _H)	—	System area		—	—	—	—	—
1384(568 _H) to 1388(56C _H)	All CHs	History 14	Error code, error occurrence time (Data structure is the same as that of History 1.)	0	R	x	x	Page 415, Appendix 2 (96)
1389(56D _H) to 1391(56F _H)	—	System area		—	—	—	—	—
1392(570 _H) to 1396(574 _H)	All CHs	History 15	Error code, error occurrence time (Data structure is the same as that of History 1.)	0	R	x	x	Page 415, Appendix 2 (96)
1397(575 _H) to 1399(577 _H)	—	System area		—	—	—	—	—
1400(578 _H) to 1404(57C _H)	All CHs	History 16	Error code, error occurrence time (Data structure is the same as that of History 1.)	0	R	x	x	Page 415, Appendix 2 (96)
1405(57D _H) to 4095(FFF _H)	—	System area		—	—	—	—	—

*1 This default value is set after the module is turned off and on or after the CPU module is reset and the reset is cancelled.

*2 This column indicates whether data can be read from or written to the buffer memory area through sequence programs.
R: Reading enabled
W: Writing enabled

*3 This column indicates whether the setting in the buffer memory area is automatically changed when the input range is changed. Enable/disable of automatic change can be set on Switch Setting. For details, refer to  Page 234, Section 8.3.3.

*4 Whether writing to the non-volatile memory by turning off and on Set value backup instruction (Yn8) is enabled in this column. For details, refer to  Page 235, Section 8.3.4.

CHAPTER 4 PROCEDURE BEFORE OPERATION

This chapter describes the procedure before operating the L60TC4.

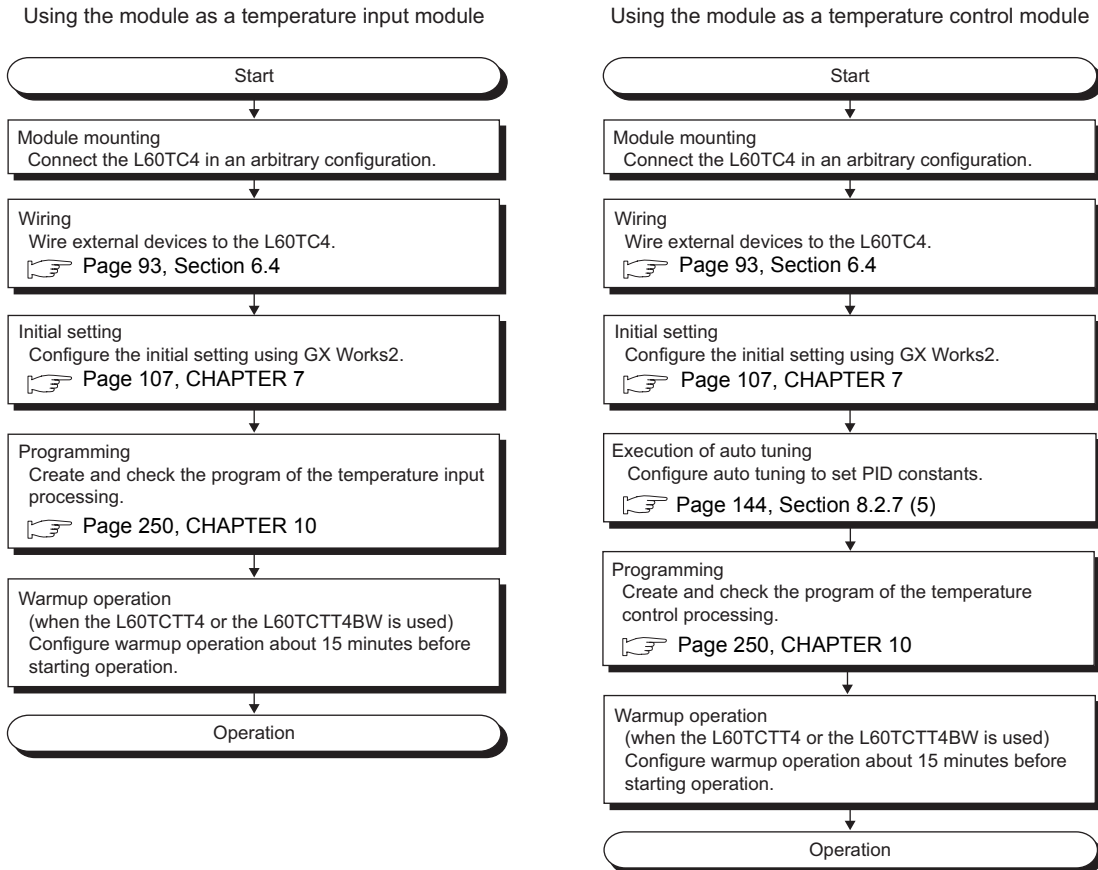

Point

When using the L60TCTT4 and the L60TCTT4BW which use the thermocouples as the temperature sensors, temperature compensation must be executed properly. Perform warm-up operation about 15 minutes before starting operation.

Memo

CHAPTER 5 SYSTEM CONFIGURATION

This chapter describes the total configuration of the L60TC4, number of connectable modules, and applicable software version.

5.1 Total Configuration

This section describes examples of system configurations when using the L60TC4.

(1) Connecting to a CPU module

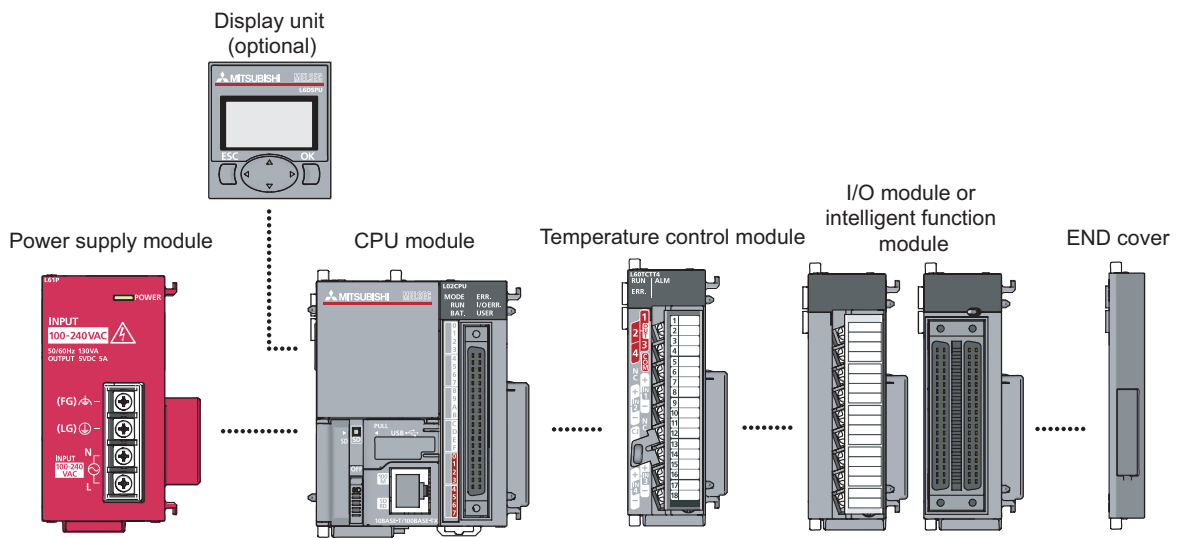

(2) Connecting to a head module

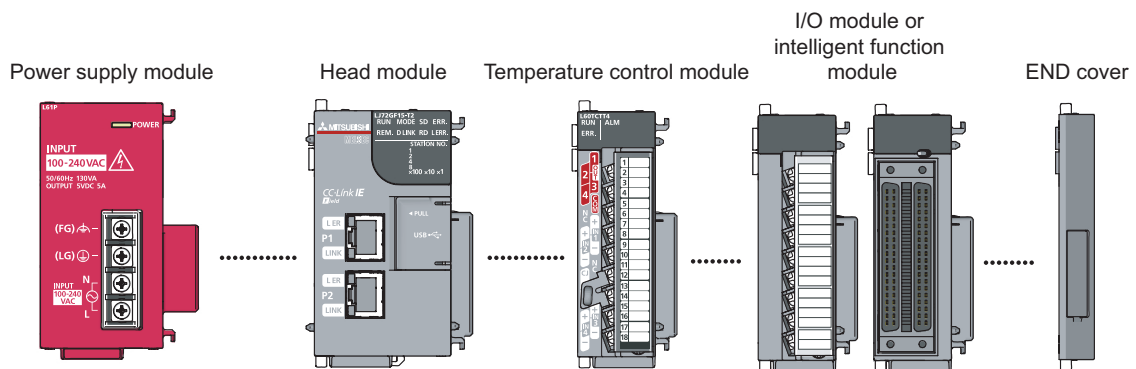



5.2 Applicable Systems

(1) Number of connectable modules



A CPU module and a head module recognize one L60TCTT4BW or L60TCRT4BW as two modules. Therefore, number of connectable modules reduces to half of other modules.

For the number of connectable modules, refer to the following manuals.

-  MELSEC-L CPU Module User's Manual (Hardware Design, Maintenance and Inspection)
-  MELSEC-L CC-Link IE Field Network Head Module User's Manual

(2) Applicable software version

For applicable software version, refer to the following manuals.

-  MELSEC-L CPU Module User's Manual (Hardware Design, Maintenance and Inspection)
-  MELSEC-L CC-Link IE Field Network Head Module User's Manual

(3) Temperature sensor

For usable temperature sensors, refer to the following.

- Types of usable temperature sensor ( Page 36, Section 3.2.2)



(4) Current sensor for heater disconnection detection

The following table lists current sensors for heater disconnection detection available with the L60TCTT4BW or L60TCRT4BW.

Model name	Remarks	Manufacturer
CTL-12-S36-8 (0.0 to 100.0A) ^{*1}	—	U.R.D.Co., LTD.
CTL-12-S36-10 (0.0 to 100.0A)		
CTL-12-S56-10 (0.0 to 100.0A)		
CTL-6-P (0.00 to 20.00A) ^{*1}		
CTL-6-P-H (0.00 to 20.00A)		

*1 The CTL-12-S36-8 and CTL-6-P can be used although they have been discontinued.

For how to select current sensors for heater disconnection detection, refer to the following.

- Selecting a current sensor for heater disconnection detection ( Page 392, Appendix 2 (60))
- Setting of the number of second-winding of connected current sensor ( Page 393, Appendix 2 (62))

5.3 Precautions for System Configuration

The L60TC4 measures temperature based on the temperature of the terminal block. Therefore, depending on the system configuration, temperature distribution of the terminal block can be uneven due to the effect of heat generated from modules, and the measured temperature may differ from actual temperature (especially when two or more L60TC4 modules are connected next to each other or the L60TC4 is mounted next to the power supply module or CPU module).

In this case, the difference between measured value and actual temperature can be reduced by the following methods.

(1) Using the sensor compensation function

The measured temperature can be corrected to the actual temperature by this function.

For details on the sensor compensation function, refer to the following.



 Page 223, Section 8.3.2

CHAPTER 6 INSTALLATION AND WIRING

This chapter describes the installation and wiring of the L60TC4.

6.1 Installation Environment and Installation Position

For precautions for installation environment and installation position, refer to the following.

-  MELSEC-L CPU Module User's Manual (Hardware Design, Maintenance and Inspection)
-  MELSEC-L CC-Link IE Field Network Head Module User's Manual

6.2 Terminal Block

(1) Precautions

Tighten the terminal block screws within the following specified torque range.

Undertightening screws may cause module dropping, failures, or malfunction. Overtightening screws can damage the screw and/or module, resulting in module dropping, short-circuit, or malfunction.

Screw location	Tightening torque range
Terminal screw (M3 screw)	0.42 to 0.58N · m
Terminal block mounting screw (M3.5 screw)	0.66 to 0.89N · m

The following table shows the applicable solderless terminal installed to the terminal block. For wiring, use the wire applicable to the following wire and mount with the applicable tightening torque. Use a UL-approved solderless terminal and tools recommended by the manufacturer of the solderless terminal. The sleeve solderless terminal cannot be used.

Solderless terminal		Wire			
Model name	Applicable tightening torque	Wire diameter	Type	Material	Temperature rating
R1.25-3	0.42 to 0.58N · m	22 to 18 AWG	Stranded wire	Copper wire	75°C or more

(2) Signal names of terminal blocks

The following shows signal names of terminal blocks.

(a) L60TCTT4, L60TCTT4BW (terminal block for I/O)

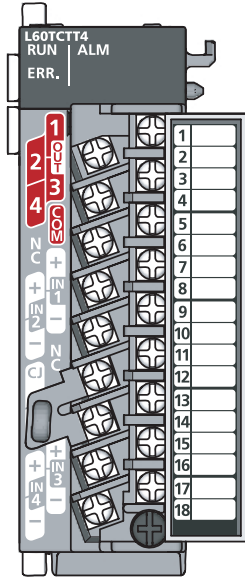

Terminal number	Indication	Temperature input		Standard control	
		Symbol	Name	Symbol	Name
1	OUT1	—	Unused	L1	CH1 Output
2	OUT2	—	Unused	L2	CH2 Output
3	OUT3	—	Unused	L3	CH3 Output
4	OUT4	—	Unused	L4	CH4 Output
5	COM	—	Unused	COM-	Output common
6	NC	NC	Unused	NC	Unused
7	IN1+	MT1+	Monitor 1 thermocouple +	CH1+	CH1 Thermocouple +
8	IN2+	MT2+	Monitor 2 thermocouple +	CH2+	CH2 Thermocouple +
9	IN1-	MT1-	Monitor 1 thermocouple -	CH1-	CH1 Thermocouple -
10	IN2-	MT2-	Monitor 2 thermocouple -	CH2-	CH2 Thermocouple -
11	NC	NC	Unused	NC	Unused
12	CJ	CJ	Cold junction temperature compensation resistor	CJ	Cold junction temperature compensation resistor
13	NC	NC	Unused	NC	Unused
14	CJ	CJ	Cold junction temperature compensation resistor	CJ	Cold junction temperature compensation resistor
15	IN3+	MT3+	Monitor 3 thermocouple +	CH3+	CH3 Thermocouple +
16	IN4+	MT4+	Monitor 4 thermocouple +	CH4+	CH4 Thermocouple +
17	IN3-	MT3-	Monitor 3 thermocouple -	CH3-	CH3 Thermocouple -
18	IN4-	MT4-	Monitor 4 thermocouple -	CH4-	CH4 Thermocouple -

Terminal number	Indication	Heating-cooling control (normal mode)		Heating-cooling control (expanded mode)		Mix control (normal mode)		Mix control (expanded mode)	
		Symbol	Name	Symbol	Name	Symbol	Name	Symbol	Name
1	OUT1	L1H	CH1 Heating output	L1H	CH1 Heating output	L1H	CH1 Heating output	L1H	CH1 Heating output
2	OUT2	L1C	CH1 Cooling output	L1C	CH1 Cooling output	L1C	CH1 Cooling output	L1C	CH1 Cooling output
3	OUT3	L2H	CH2 Heating output	L2H	CH2 Heating output	L3	CH3 Output	L3	CH3 Output
4	OUT4	L2C	CH2 Cooling output	L2C	CH2 Cooling output	L4	CH4 Output	L4	CH4 Output
5	COM	COM-	Output common	COM-	Output common	COM-	Output common	COM-	Output common
6	NC	NC	Unused	NC	Unused	NC	Unused	NC	Unused
7	IN1+	CH1+	CH1 Thermocouple +	CH1+	CH1 Thermocouple +	CH1+	CH1 Thermocouple +	CH1+	CH1 Thermocouple +
8	IN2+	CH2+	CH2 Thermocouple +	CH2+	CH2 Thermocouple +	MT2+	Monitor 2 thermocouple +	CH2+	CH2 Thermocouple +
9	IN1-	CH1-	CH1 Thermocouple -	CH1-	CH1 Thermocouple -	CH1-	CH1 Thermocouple -	CH1-	CH1 Thermocouple -
10	IN2-	CH2-	CH2 Thermocouple -	CH2-	CH2 Thermocouple -	MT2-	Monitor 2 thermocouple -	CH2-	CH2 Thermocouple -
11	NC	NC	Unused	NC	Unused	NC	Unused	NC	Unused
12	CJ	CJ	Cold junction temperature compensation resistor	CJ	Cold junction temperature compensation resistor	CJ	Cold junction temperature compensation resistor	CJ	Cold junction temperature compensation resistor
13	NC	NC	Unused	NC	Unused	NC	Unused	NC	Unused
14	CJ	CJ	Cold junction temperature compensation resistor	CJ	Cold junction temperature compensation resistor	CJ	Cold junction temperature compensation resistor	CJ	Cold junction temperature compensation resistor
15	IN3+	MT3+	Monitor 3 thermocouple +	CH3+	CH3 Thermocouple +	CH3+	CH3 Thermocouple +	CH3+	CH3 Thermocouple +
16	IN4+	MT4+	Monitor 4 thermocouple +	CH4+	CH4 Thermocouple +	CH4+	CH4 Thermocouple +	CH4+	CH4 Thermocouple +
17	IN3-	MT3-	Monitor 3 thermocouple -	CH3-	CH3 Thermocouple -	CH3-	CH3 Thermocouple -	CH3-	CH3 Thermocouple -
18	IN4-	MT4-	Monitor 4 thermocouple -	CH4-	CH4 Thermocouple -	CH4-	CH4 Thermocouple -	CH4-	CH4 Thermocouple -

Point!

Do not remove the cold junction temperature compensation resistor from the terminal block.

(b) L60TCRT4, L60TCRT4BW (terminal block for I/O)

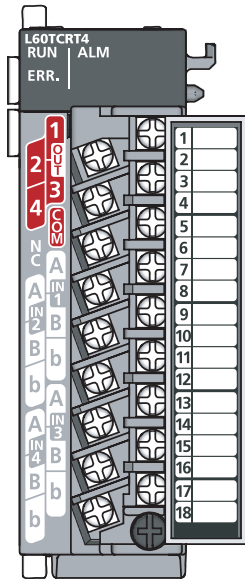

Terminal number	Indication	Temperature input		Standard control	
		Symbol	Name	Symbol	Name
1	OUT1	—	Unused	L1	CH1 Output
2	OUT2	—	Unused	L2	CH2 Output
3	OUT3	—	Unused	L3	CH3 Output
4	OUT4	—	Unused	L4	CH4 Output
5	COM	—	Unused	COM-	Output common
6	NC	NC	Unused	NC	Unused
7	IN1 A	MT1 A	Monitor 1 resistance thermometer A	CH1 A	CH1 Resistance thermometer A
8	IN2 A	MT2 A	Monitor 2 resistance thermometer A	CH2 A	CH2 Resistance thermometer A
9	IN1 B	MT1 B	Monitor 1 resistance thermometer B	CH1 B	CH1 Resistance thermometer B
10	IN2 B	MT2 B	Monitor 2 resistance thermometer B	CH2 B	CH2 Resistance thermometer B
11	IN1 b	MT1 b	Monitor 1 resistance thermometer b	CH1 b	CH1 Resistance thermometer b
12	IN2 b	MT2 b	Monitor 2 resistance thermometer b	CH2 b	CH2 Resistance thermometer b
13	IN3 A	MT3 A	Monitor 3 resistance thermometer A	CH3 A	CH3 Resistance thermometer A
14	IN4 A	MT4 A	Monitor 4 resistance thermometer A	CH4 A	CH4 Resistance thermometer A
15	IN3 B	MT3 B	Monitor 3 resistance thermometer B	CH3 B	CH3 Resistance thermometer B
16	IN4 B	MT4 B	Monitor 4 resistance thermometer B	CH4 B	CH4 Resistance thermometer B
17	IN3 b	MT3 b	Monitor 3 resistance thermometer b	CH3 b	CH3 Resistance thermometer b
18	IN4 b	MT4 b	Monitor 4 resistance thermometer b	CH4 b	CH4 Resistance thermometer b

Terminal number	Indication	Heating-cooling control (normal mode)		Heating-cooling control (expanded mode)		Mix control (normal mode)		Mix control (expanded mode)	
		Symbol	Name	Symbol	Name	Symbol	Name	Symbol	Name
1	OUT1	L1H	CH1 Heating output	L1H	CH1 Heating output	L1H	CH1 Heating output	L1H	CH1 Heating output
2	OUT2	L1C	CH1 Cooling output	L1C	CH1 Cooling output	L1C	CH1 Cooling output	L1C	CH1 Cooling output
3	OUT3	L2H	CH2 Heating output	L2H	CH2 Heating output	L3	CH3 Output	L3	CH3 Output
4	OUT4	L2C	CH2 Cooling output	L2C	CH2 Cooling output	L4	CH4 Output	L4	CH4 Output
5	COM	COM-	Output common	COM-	Output common	COM-	Output common	COM-	Output common
6	NC	NC	Unused	NC	Unused	NC	Unused	NC	Unused
7	IN1 A	CH1 A	CH1 Resistance thermometer A	CH1 A	CH1 Resistance thermometer A	CH1 A	CH1 Resistance thermometer A	CH1 A	CH1 Resistance thermometer A
8	IN2 A	CH2 A	CH2 Resistance thermometer A	CH2 A	CH2 Resistance thermometer A	MT2 A	Monitor 2 resistance thermometer A	CH2 A	CH2 Resistance thermometer A
9	IN1 B	CH1 B	CH1 Resistance thermometer B	CH1 B	CH1 Resistance thermometer B	CH1 B	CH1 Resistance thermometer B	CH1 B	CH1 Resistance thermometer B
10	IN2 B	CH2 B	CH2 Resistance thermometer B	CH2 B	CH2 Resistance thermometer B	MT2 B	Monitor 2 resistance thermometer B	CH2 B	CH2 Resistance thermometer B
11	IN1 b	CH1 b	CH1 Resistance thermometer b	CH1 b	CH1 Resistance thermometer b	CH1 b	CH1 Resistance thermometer b	CH1 b	CH1 Resistance thermometer b
12	IN2 b	CH2 b	CH2 Resistance thermometer b	CH2 b	CH2 Resistance thermometer b	MT2 b	Monitor 2 resistance thermometer b	CH2 b	CH2 Resistance thermometer b
13	IN3 A	MT3 A	Monitor 3 resistance thermometer A	CH3 A	CH3 Resistance thermometer A	CH3 A	CH3 Resistance thermometer A	CH3 A	CH3 Resistance thermometer A
14	IN4 A	MT4 A	Monitor 4 resistance thermometer A	CH4 A	CH4 Resistance thermometer A	CH4 A	CH4 Resistance thermometer A	CH4 A	CH4 Resistance thermometer A
15	IN3 B	MT3 B	Monitor 3 resistance thermometer B	CH3 B	CH3 Resistance thermometer B	CH3 B	CH3 Resistance thermometer B	CH3 B	CH3 Resistance thermometer B
16	IN4 B	MT4 B	Monitor 4 resistance thermometer B	CH4 B	CH4 Resistance thermometer B	CH4 B	CH4 Resistance thermometer B	CH4 B	CH4 Resistance thermometer B
17	IN3 b	MT3 b	Monitor 3 resistance thermometer b	CH3 b	CH3 Resistance thermometer b	CH3 b	CH3 Resistance thermometer b	CH3 b	CH3 Resistance thermometer b
18	IN4 b	MT4 b	Monitor 4 resistance thermometer b	CH4 b	CH4 Resistance thermometer b	CH4 b	CH4 Resistance thermometer b	CH4 b	CH4 Resistance thermometer b

(c) L60TCTT4BW (terminal block for CT), L60TCRT4BW (terminal block for CT)

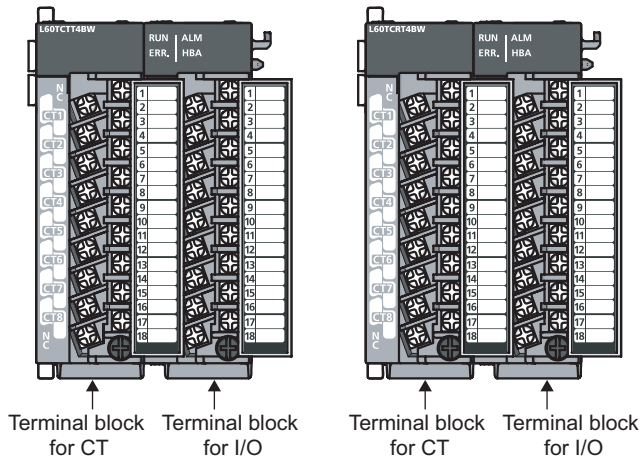

Terminal number	Indication	Standard control	
		Symbol	Name
1	NC	NC	Unused
2	CT1	CT1	CT input 1
3	CT1	CT1	CT input 1
4	CT2	CT2	CT input 2
5	CT2	CT2	CT input 2
6	CT3	CT3	CT input 3
7	CT3	CT3	CT input 3
8	CT4	CT4	CT input 4
9	CT4	CT4	CT input 4
10	CT5	CT5	CT input 5
11	CT5	CT5	CT input 5
12	CT6	CT6	CT input 6
13	CT6	CT6	CT input 6
14	CT7	CT7	CT input 7
15	CT7	CT7	CT input 7
16	CT8	CT8	CT input 8
17	CT8	CT8	CT input 8
18	NC	NC	Unused

(3) Removal and installation of the terminal block

The following shows how to remove and install the terminal block.

(a) Removal procedure

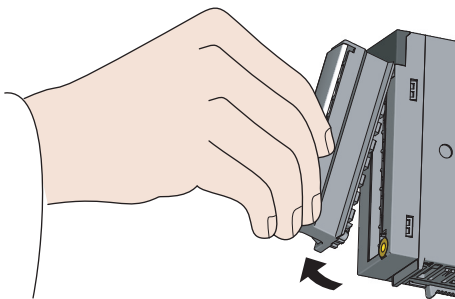
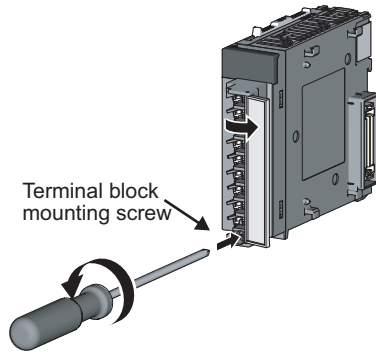

1. Open the terminal cover and loosen the terminal block mounting screw.

2. Using the terminal block fixing hole as a supporting point, remove the terminal block.

(b) Installation procedure

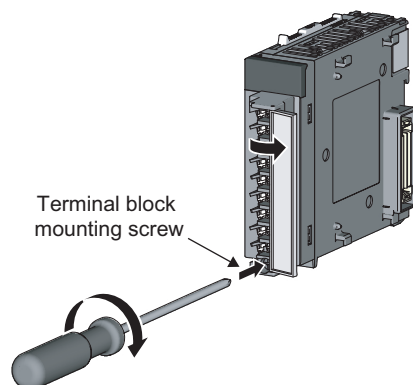
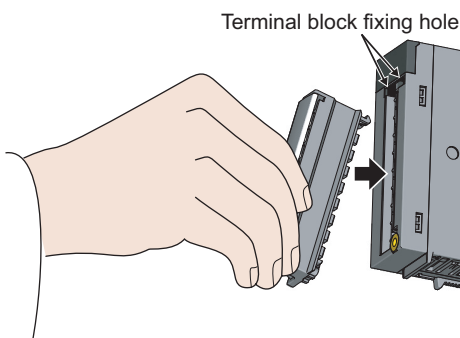

1. Fully insert the projections on the top of the terminal block into the terminal block fixing holes of the module and press the terminal block until it snaps into place.

2. Open the terminal cover and tighten the terminal block mounting screw.

6.3 Wiring precautions

External wiring that is less susceptible to noise is required as a condition of enabling a highly reliable system and making full use of the capabilities of the L60TC4.

The following figure shows the wiring precautions.

- Use separate cables with the AC control circuit and the L60TC4's external input signals to avoid the influence of AC side surges and induction.
- Do not bunch the cables with the main circuit cable, high-voltage cable, or load cables from other than the programmable controller, or install them close to each other.
Install the cables far apart from high-frequency circuit cable, such as the high-voltage cable and inverter load main circuit, as much as possible.

This increases the noises, surges, and induction.

- Ground the shield line or shielded cable at one end on the programmable controller side. However, depending on the external noise condition, it should be grounded externally.
- For conformance of this product with the EMC Directive and Low Voltage Directive, refer to the following.

 MELSEC-L CPU Module User's Manual (Hardware Design, Maintenance and Inspection)

 MELSEC-L CC-Link IE Field Network Head Module User's Manual

6.4 External wiring

The following figure shows the external wiring.

6.4.1 L60TCTT4

(1) In the temperature input mode

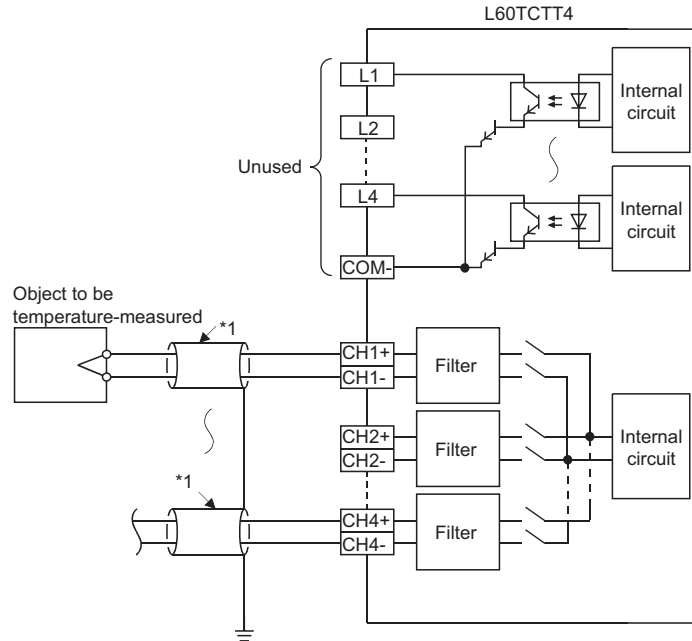

*1 Use the shielded compensation lead wire.

Point

Use the compensation lead wire for the cable of thermocouple. If the compensation lead wire is not used, and when the cold junction temperature compensation resistor is away from the end tip of thermocouple, the (ambient) temperature difference may lead to a faulty temperature process value (PV).

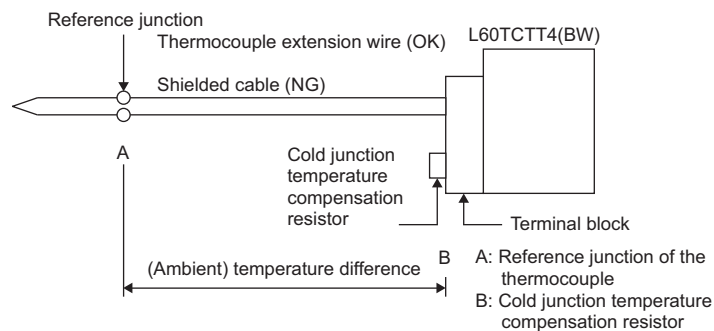

(2) In the temperature control mode

(a) In the standard control

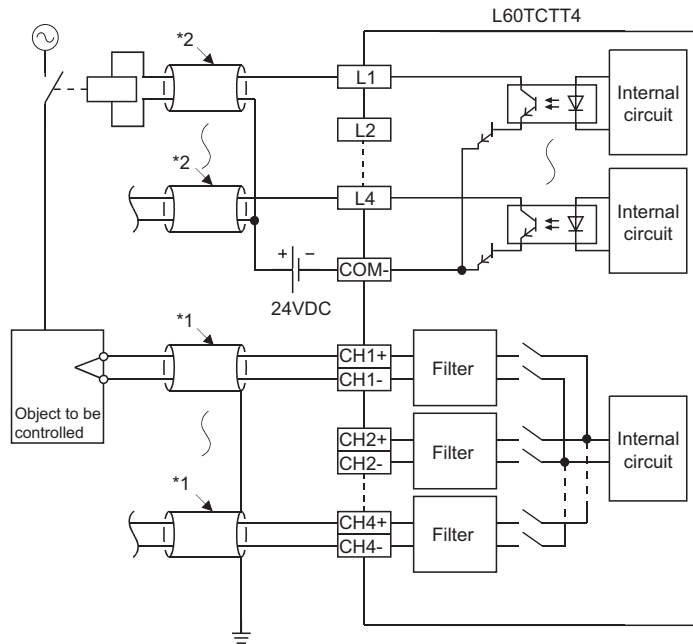

- *1 Use the shielded compensation lead wire.
- *2 Use the shielded cable.

Point

Use the compensation lead wire for the cable of thermocouple. If the compensation lead wire is not used, and when the cold junction temperature compensation resistor is away from the end tip of thermocouple, the (ambient) temperature difference may lead to a faulty temperature process value (PV).

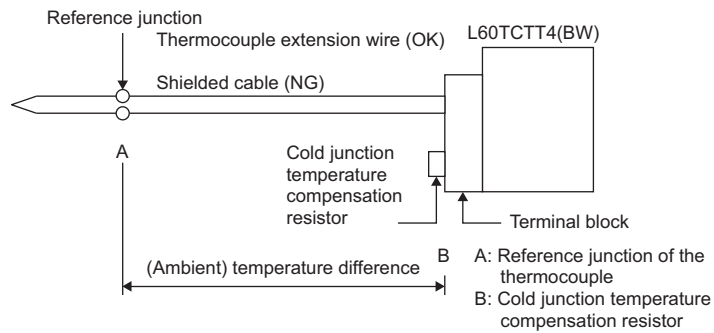

(b) In the heating-cooling control

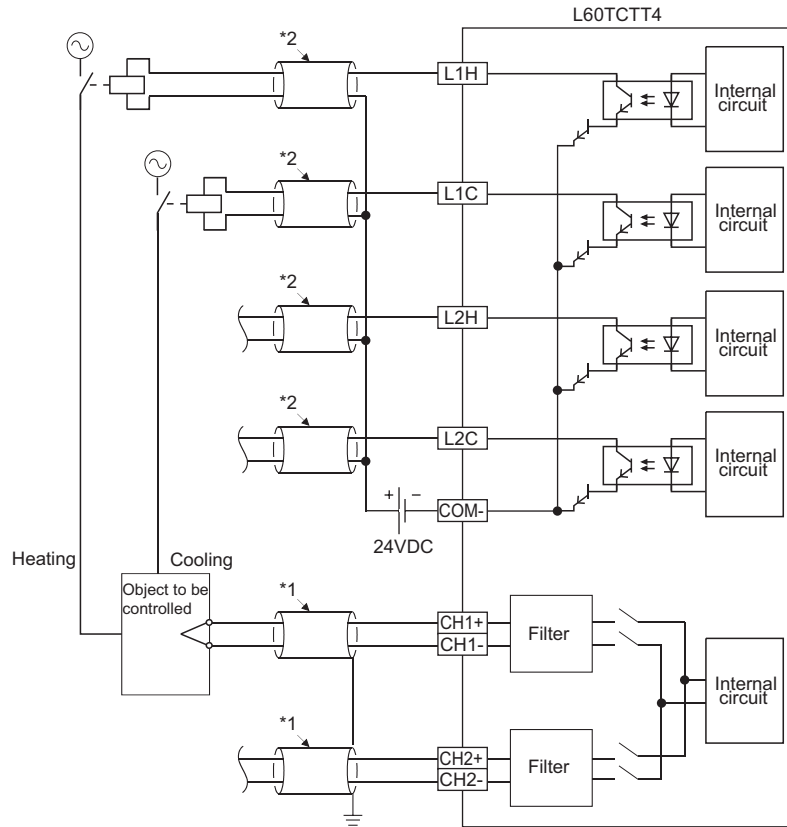

- *1 Use the shielded compensation lead wire.
- *2 Use the shielded cable.

Point

Use the compensation lead wire for the cable of thermocouple. If the compensation lead wire is not used, and when the cold junction temperature compensation resistor is away from the end tip of thermocouple, the (ambient) temperature difference may lead to a faulty temperature process value (PV).

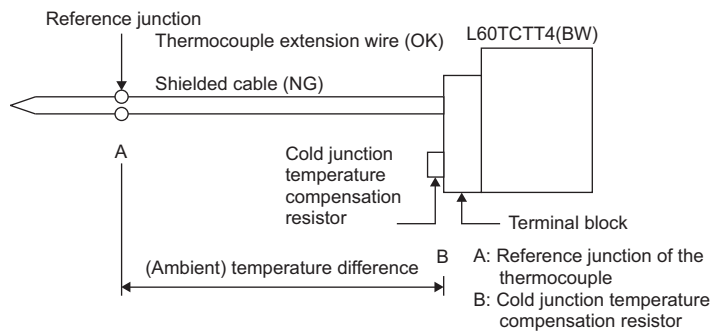

6.4.2 L60TCTT4BW

(1) In the temperature input mode

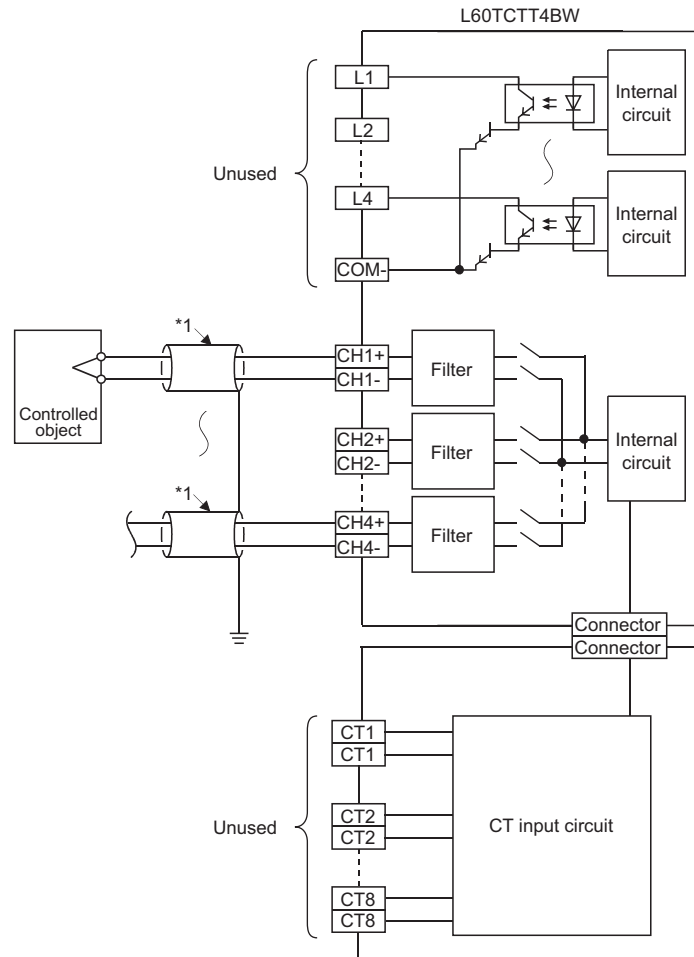

*1 Use the shielded compensation lead wire.

Point

Use the compensation lead wire for the cable of thermocouple. If the compensation lead wire is not used, and when the cold junction temperature compensation resistor is away from the end tip of thermocouple, the (ambient) temperature difference may lead to a faulty temperature process value (PV).

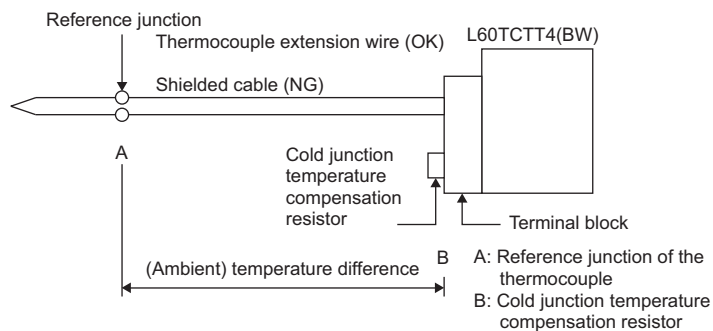

(2) In the temperature control mode

(a) In the standard control

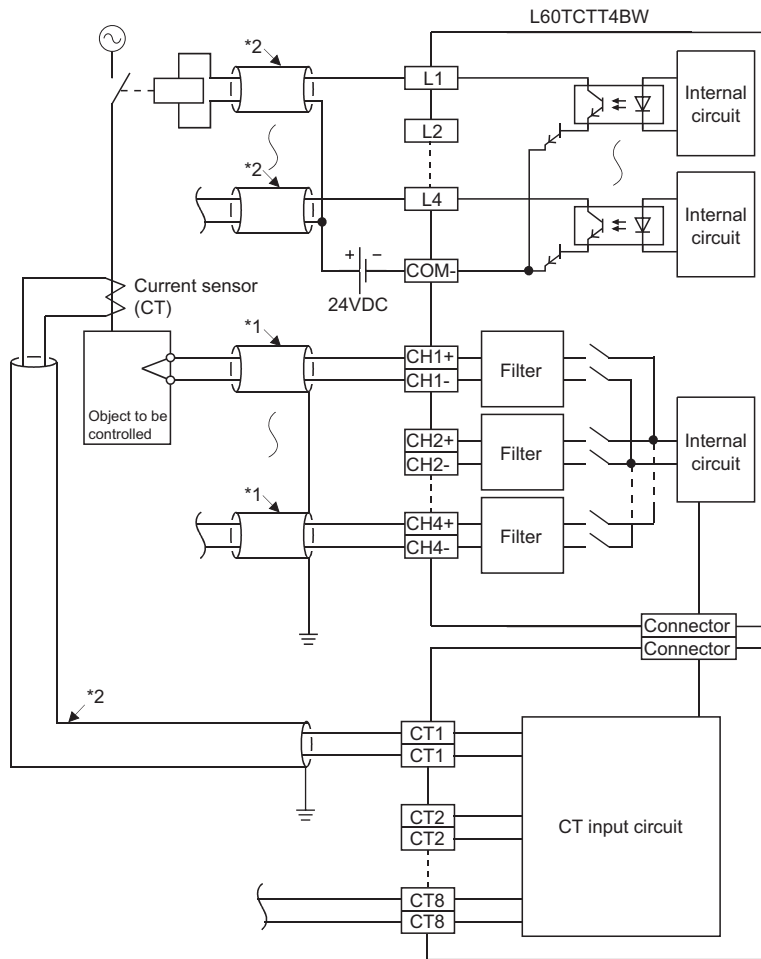

- *1 Use the shielded compensation lead wire.
- *2 Use the shielded cable.

Point

- To use the heater disconnection detection function, the CT input channel assignment must be set. Since the CT1 is used in the loop of CH1 in the above wiring example, set CH1(1) to CT1 CT input channel assignment setting (Un/G264).
- Use the compensation lead wire for the cable of thermocouple. If the compensation lead wire is not used, and when the cold junction temperature compensation resistor is away from the end tip of thermocouple, the (ambient) temperature difference may lead to a faulty temperature process value (PV).

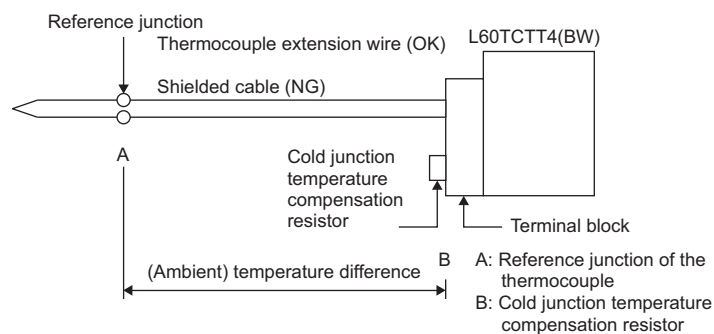

6
6.4 External wiring
6.4.2 L60TCTT4BW

(b) In the heating-cooling control

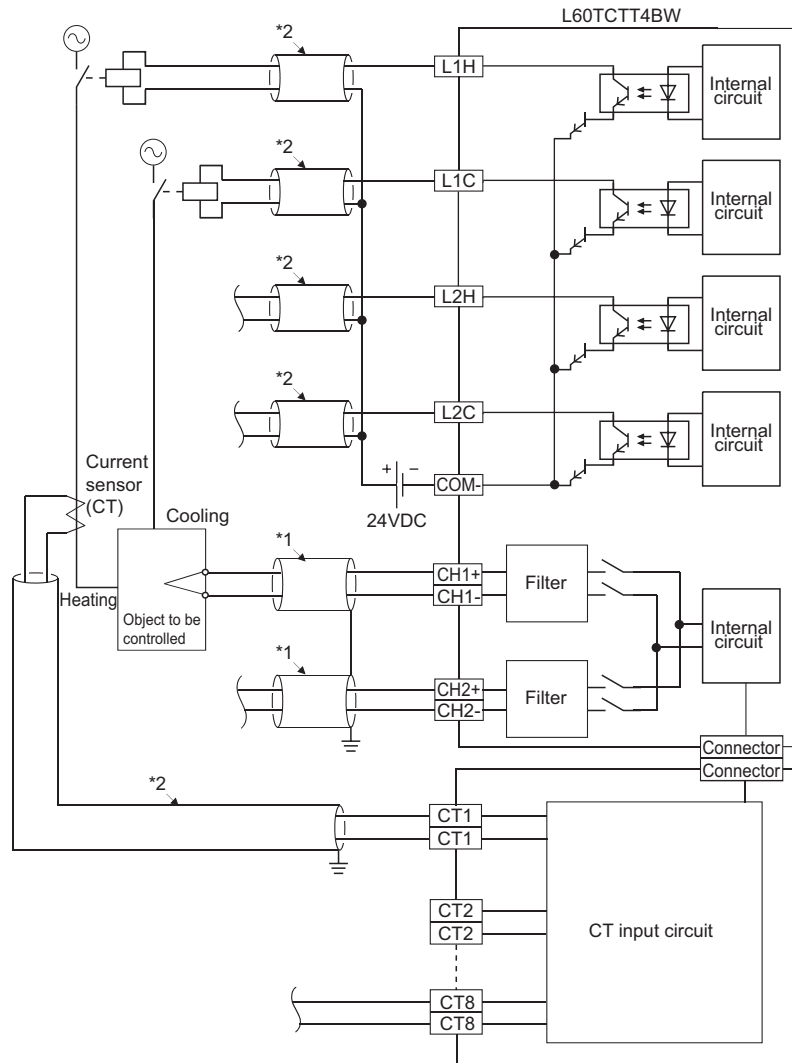

- *1 Use the shielded compensation lead wire.
- *2 Use the shielded cable.

Point

- To use the heater disconnection detection function, the CT input channel assignment must be set. Since the CT1 is used in the loop of CH1 in the above wiring example, set CH1(1) to CT1 CT input channel assignment setting (Un\G264).
- Use the compensation lead wire for the cable of thermocouple. If the compensation lead wire is not used, and when the cold junction temperature compensation resistor is away from the end tip of thermocouple, the (ambient) temperature difference may lead to a faulty temperature process value (PV).

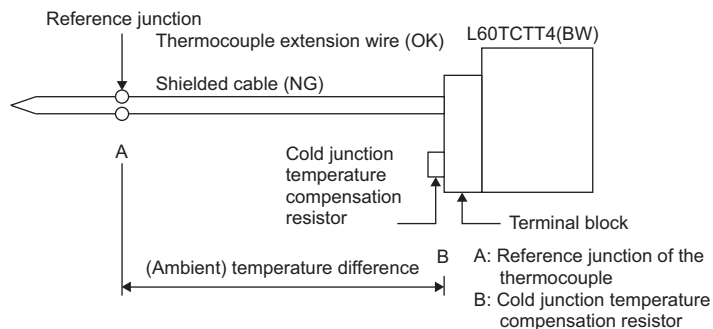

6.4.3 L60TCRT4

(1) In the temperature input mode

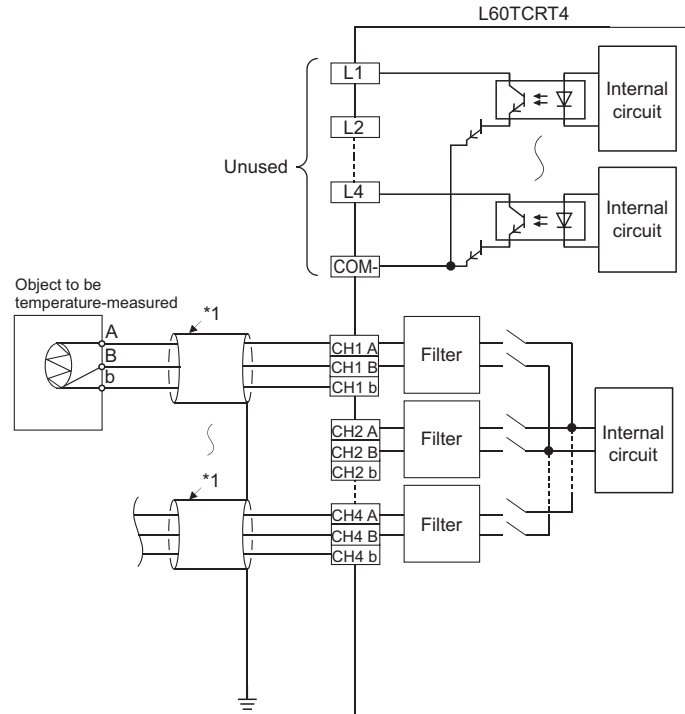

*1 Use the shielded cable.

(2) In the temperature control mode

(a) In the standard control

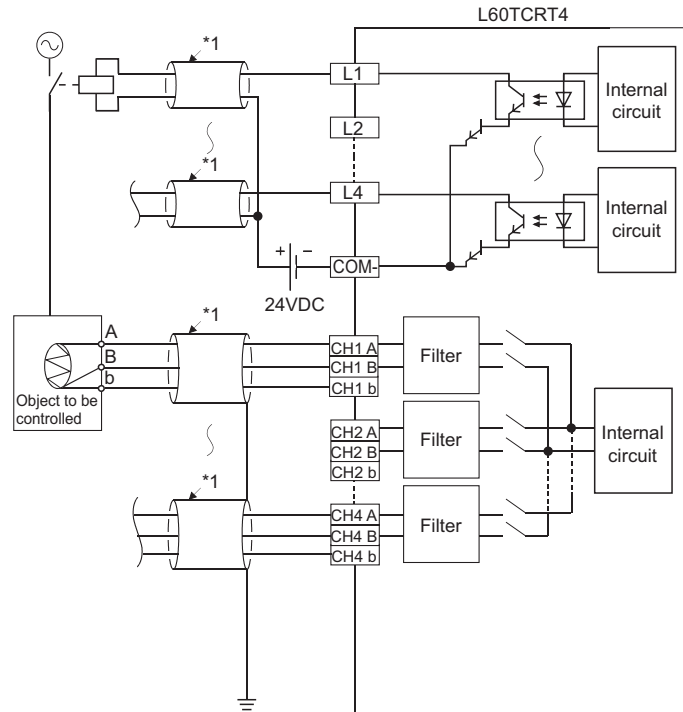

*1 Use the shielded cable.

(b) In the heating-cooling control

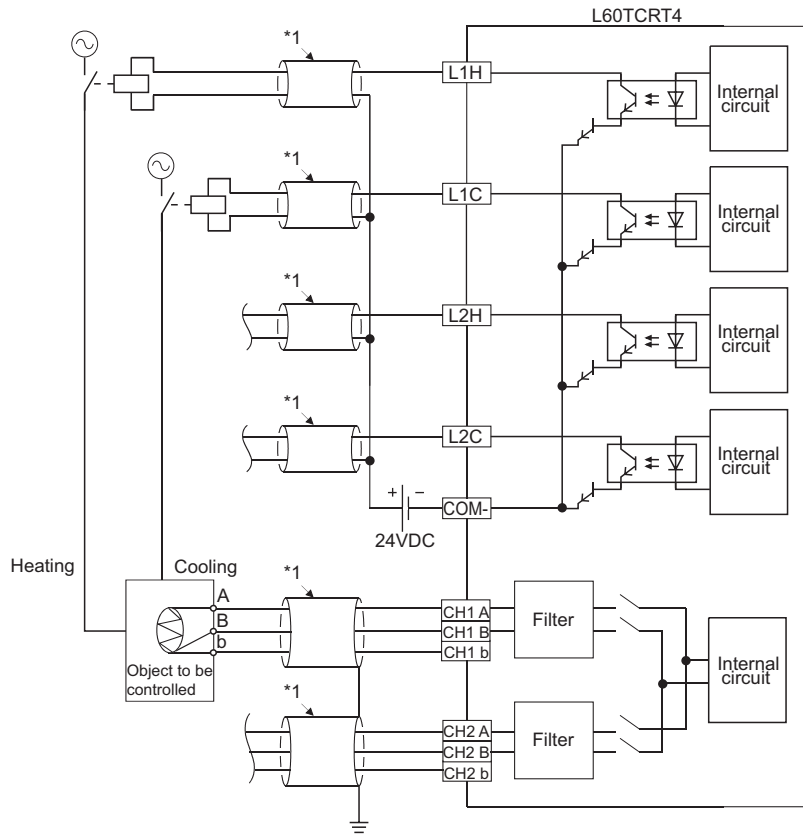

*1 Use the shielded cable.

6.4.4 L60TCRT4BW

(1) In the temperature input mode

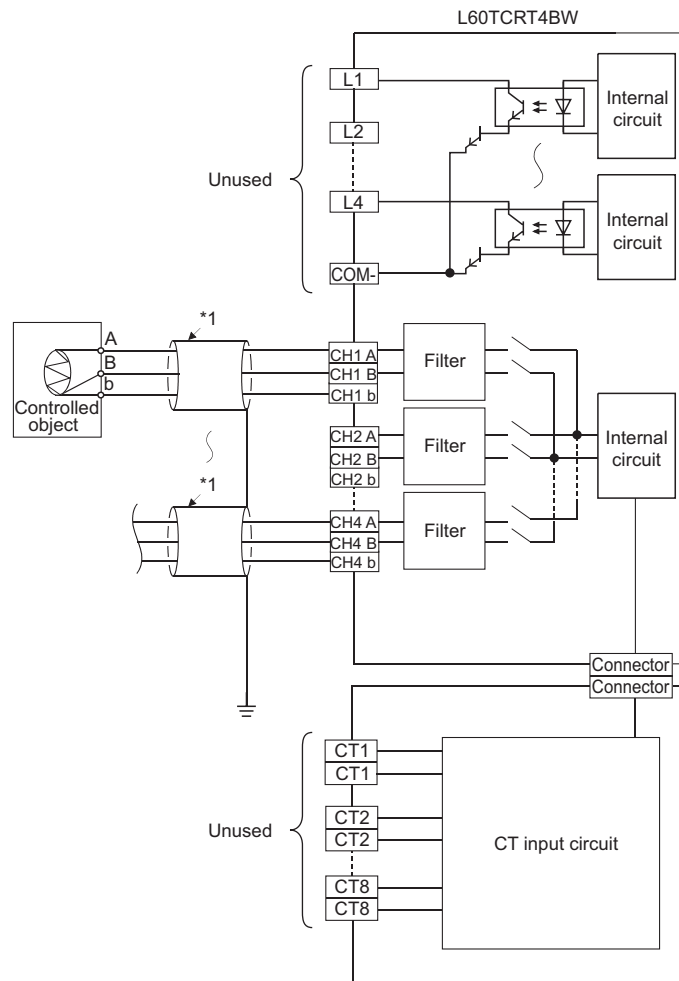

*1 Use the shielded cable.

(2) In the temperature control mode

(a) In the standard control

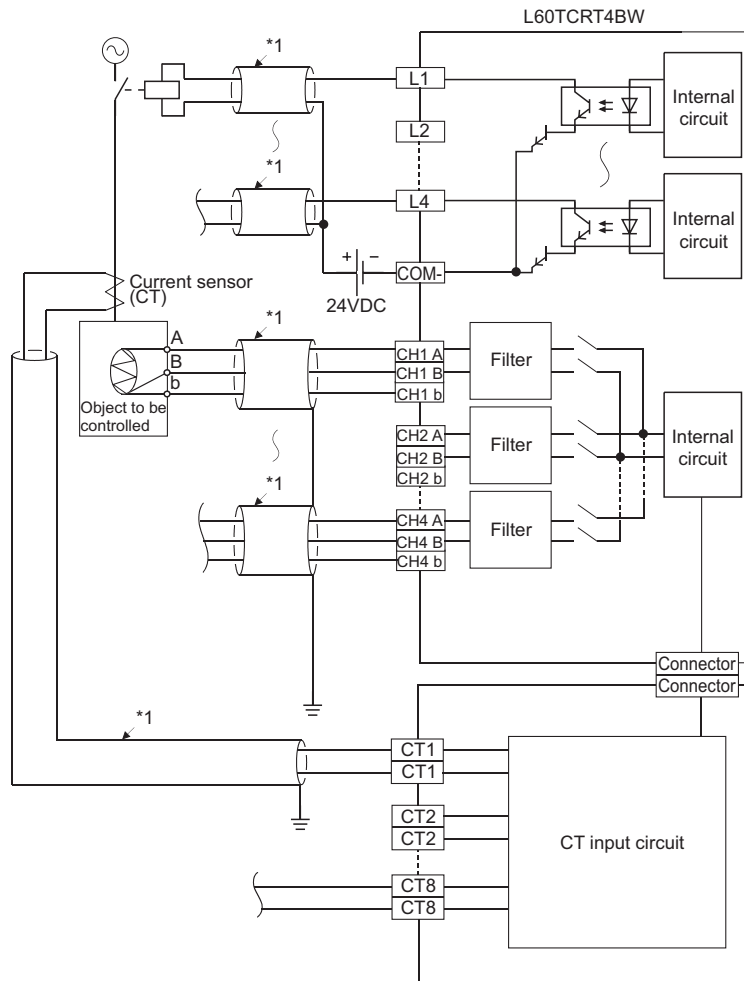

*1 Use the shielded cable.

Point

To use the heater disconnection detection function, the CT input channel assignment must be set. Since the CT1 is used in the loop of CH1 in the above wiring example, set CH1(1) to CT1 CT input channel assignment setting (Un\G264).

(b) In the heating-cooling control

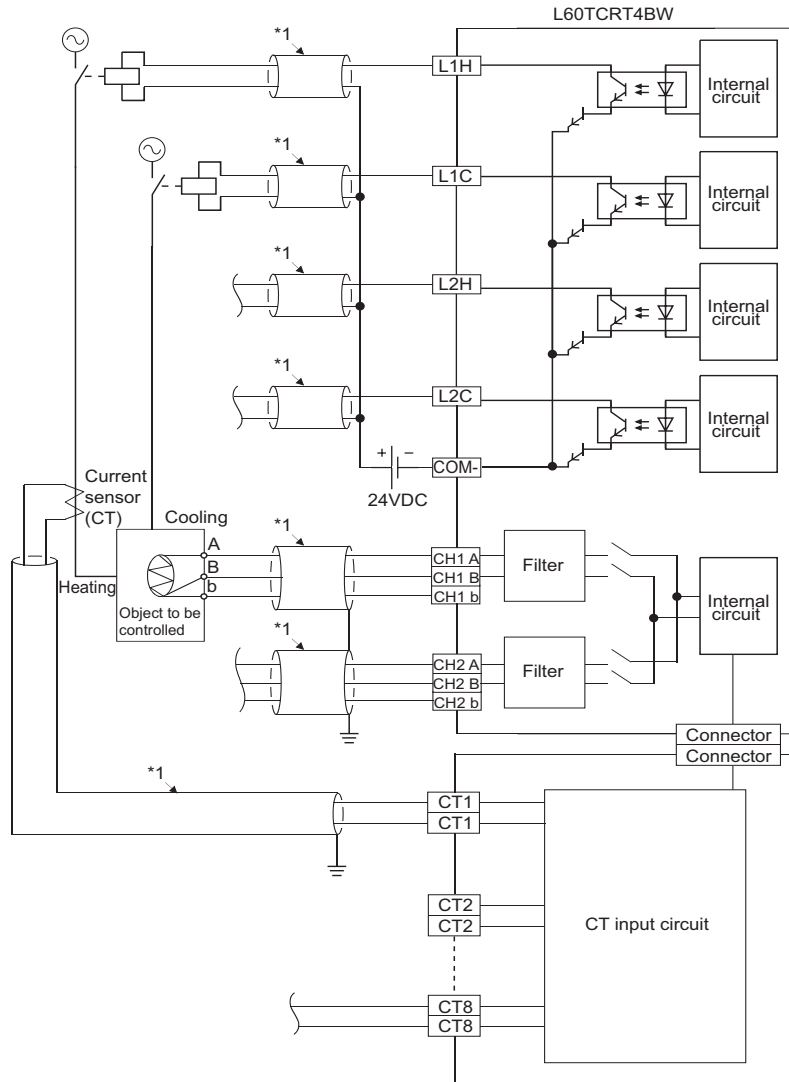

*1 Use the shielded cable.

Point

To use the heater disconnection detection function, the CT input channel assignment must be set. Since the CT1 is used in the loop of CH1 in the above wiring example, set CH1(1) to CT1 CT input channel assignment setting (Un\G264).

6.5 Heater disconnection detection wiring and setting example for three-phase heater

The following figure shows a wiring and setting example to detect a three-phase heater disconnection by using the heater disconnection detection function.

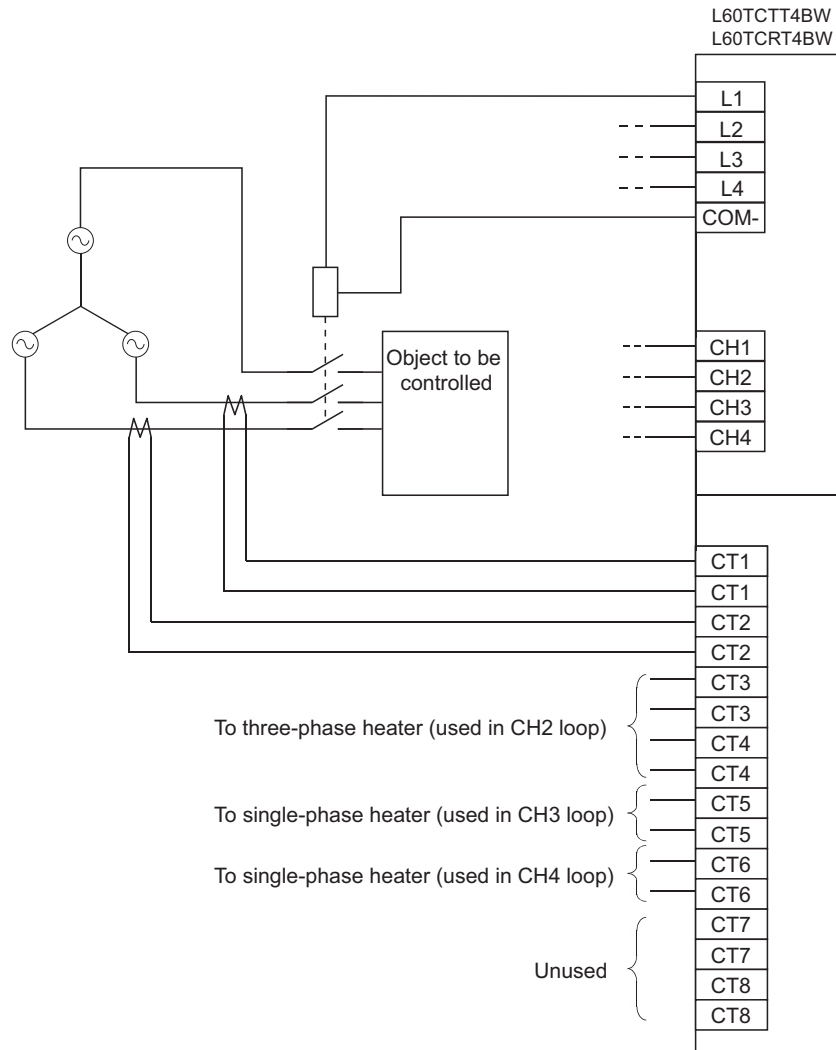

Three-phase heater disconnection detection is executed by measuring the currents of two of the three cables. In the above wiring example, set CT□ CT input channel assignment setting (Un\G264 to Un\G271) as indicated below.

CT input	Buffer memory address	Set value
CT1	Un\G264	1
CT2	Un\G265	1
CT3	Un\G266	2
CT4	Un\G267	2
CT5	Un\G268	3
CT6	Un\G269	4
CT7	Un\G270	0
CT8	Un\G271	0

6.6 Unused Channel Setting

When no temperature sensor is connected to a channel, the L60TC4 performs upscale processing for the channel. Therefore, when a temperature sensor is not connected to a channel where no temperature control is performed, the module determines that the temperature process value (PV) has exceeded the temperature measurement range for the input range, and the ALM LED blinks.

Once the unused channel setting is configured, no alert will occur for a channel where a temperature sensor is not connected. To prevent faulty alert detection, configure the unused channel setting.

(1) Setting method

Set a value in CH□ unused channel setting (Un\G61, Un\G93, Un\G125, Un\G157).

For details on the setting, refer to the following.

 Page 376, Appendix 2 (35)

The following table shows the relationship between the setting value and control status.

Set value	Control status		
	PID control	Temperature judgment	Alert judgment
0: Use	The controls are performed. (However, it depends on other setting status.)		
1: Unused	The controls are not performed.		

Remark

Even if the unused channel setting is configured, the sampling cycle does not change.

CHAPTER 7 VARIOUS SETTINGS

This chapter describes the setting procedures of the L60TC4.

Point

After writing the contents of the new module, switch setting, parameter setting and auto refresh setting into the CPU module, reset the CPU module, switch STOP → RUN → STOP → RUN, or turn off and on the power, to enable the setting contents.

7.1 Addition of Modules

Add the model name of the L60TC4 to use on the project.

(1) Addition procedure

Open the "New Module..." window.

Project window ⇨ [Intelligent Function Module] ⇨ Right-click ⇨ [New Module...]

Item		Description
Module Selection	Module Type	Set "Temperature Control Module".
	Module Name	Select the module name to connect.
Mount Position	Mounted Slot No.	Set the slot No. where the module is connected.
	Specify start XY address	The start I/O number (hexadecimal) of the target module is set according to the mounted slot No.. An arbitrary start I/O number can be also set.
Title Setting	Title	Set an arbitrary title.

7.2 Switch Setting

Configure settings such as the output setting at CPU stop error and the control mode selection which are used in each channel.

(1) Setting method

Open the "Switch Setting" window.

 Project window ⇨ [Intelligent Function Module] ⇨ Module name ⇨ [Switch Setting]

(a) When using the L60TC4 as a temperature input module

Select "Temperature Input Mode" →

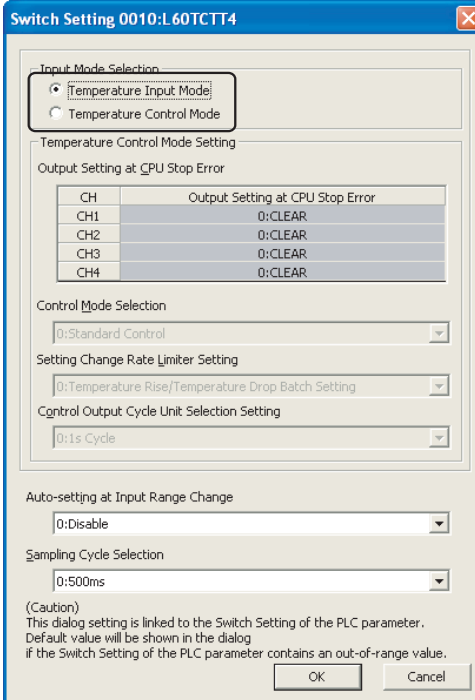

Item	Description	Set value	Reference
Auto-setting at Input Range Change	Set this item to change data of the related buffer memory automatically when the input range is changed so that an error outside the setting range does not occur.	<ul style="list-style-type: none"> • 0: Disable • 1: Enable 	Page 234, Section 8.3.3
Sampling Cycle Selection ^{*1}	Select the sampling cycle.	<ul style="list-style-type: none"> • 0: 500ms (default value) • 1: 250ms 	Page 117, Section 8.1.2

*1 Immediately after the setting is changed, a set value discrepancy error (error code: 0□□E_H) occurs. To clear the set value discrepancy error, turn off, on, and off Set value backup instruction (Yn8).

(b) When using the L60TC4 as a temperature control module

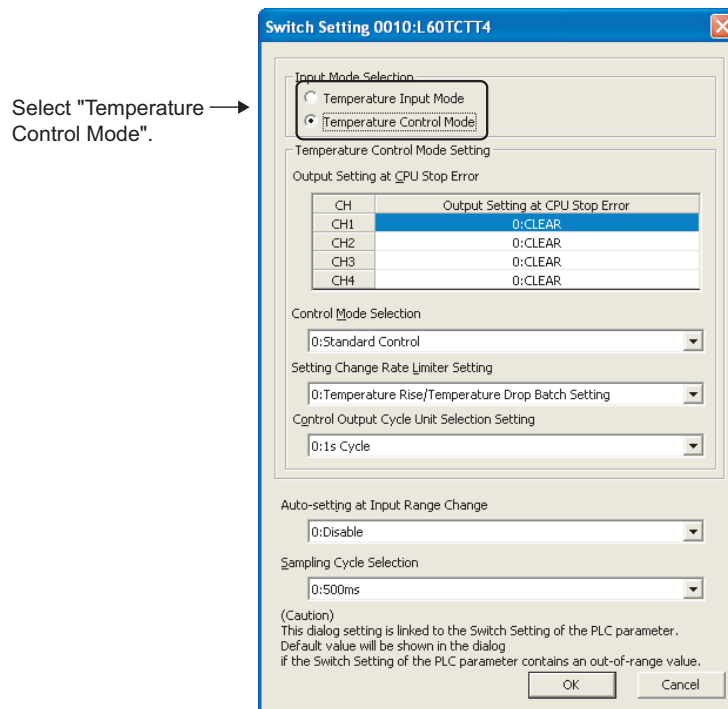

Item	Description	Set value	Reference
Output Setting at CPU Stop Error	Set whether to hold or clear the transistor output status when a CPU stop error occurs or when a CPU module is switched from RUN to STOP.	<ul style="list-style-type: none"> • 0: CLEAR (default value) • 1: HOLD 	Page 128, Section 8.2.2
Control Mode Selection* ¹	Set the control mode.	<ul style="list-style-type: none"> • 0: Standard Control • 1: Heating/Cooling Control (Normal Mode) • 2: Heating/Cooling Control (Expanded Mode) • 3: Mix Control (Normal Mode) • 4: Mix Control (Expanded Mode) 	Page 126, Section 8.2.1
Setting Change Rate Limiter Setting	Select "batch" setting or "individual" setting for the variation limiter set value at temperature rise and drop when setting the variation of the set value (SV).	<ul style="list-style-type: none"> • 0: Temperature Rise/Temperature Drop Batch setting • 1: Temperature Rise/Temperature Drop Individual setting 	Page 155, Section 8.2.10
Control Output Cycle Unit Selection Setting* ¹	Select 0.1s or 1s as a unit for the cycle of turning on and off the transistor output.	<ul style="list-style-type: none"> • 0: 1s cycle (default value) • 1: 0.1s cycle 	Page 140, Section 8.2.6
Auto-setting at Input Range Change	Set this item to change data of the related buffer memory automatically when the input range is changed so that an error which is out of the setting does not occur.	<ul style="list-style-type: none"> • 0: Disable • 1: Enable 	Page 234, Section 8.3.3
Sampling Cycle Selection* ¹	Select the sampling cycle.	<ul style="list-style-type: none"> • 0: 500ms (default value) • 1: 250ms 	—

*¹ Immediately after the setting is changed, a set value discrepancy error (error code: 0□□E_H) occurs. To clear the set value discrepancy error, turn off, on, and off Set value backup instruction (Yn8).

7.3 Parameter Setting

Set the parameter for each channel.

By setting parameters here, the parameter setting is not required on a program.

(1) Setting method

Open the "Parameter" window.

1. Start up "Parameter" on the Project window.

Project window ⇨ [Intelligent Function Module] ⇨ Module name ⇨ [Parameter]

Clear Value for Gray Cells button

Pull-down list type

Text box type

Item	CH1	CH2	CH3	CH4
Basic setting				
Set the temperature conversion system.				
Input range	2:Thermocouple Measured Temperature Range(0 to 1300	2:Thermocouple Measured Temperature Range(0 to 1300	2:Thermocouple Measured Temperature Range(0 to 1300	2:Thermocouple Measured Temperature Range(0 to 1300
Set value (SV) setting	0 C	0 C	0 C	0 C
Unused channel setting	0:Used	:Used	0:Used	0:Used
Conversion enable/disable setting	0:Used	:Enable	0:Enable	0:Enable
Control basic parameter setting				
Temperature adjustment control automatically by merely setting the PID constants				
Proportional band (P) setting/Heating control proportional band setting (Ph)	3.0 %	3.0 %	3.0 %	3.0 %
Cooling proportional band (Pc) setting	0.0 %	0.0 %	0.0 %	0.0 %
Integral time (I) setting	240 s	240 s	240 s	240 s
Derivative time (D) setting	60 s	60 s	60 s	60 s
Control output cycle setting/Heating control output cycle setting.	30 s	30 s	30 s	30 s
Control response parameter	0:Slow	0:Slow	0:Slow	0:Slow
Stop Mode Setting	1:Monitor	1:Monitor	1:Monitor	1:Monitor
PID continuation flag	0:Stop			
Control detail parameter setting				
The Q64TCTT(BW) allows you to set the temperature measurement ranges which meet the operating temperatures of the above thermocouples.				
Forward/reverse action setting	1:Reverse Action	1:Reverse Action	1:Reverse Action	1:Reverse Action
Upper limit setting limiter	1300 C	1300 C	1300 C	1300 C
Lower limit setting limiter	0 C	0 C	0 C	0 C
Setting change rate limiter or Setting change rate limiter (Temperature rise)	0.0 %	0.0 %	0.0 %	0.0 %
Setting change rate limiter (Temperature drop)	0.0 %	0.0 %	0.0 %	0.0 %
Sensor correction value setting	0.00 %	0.00 %	0.00 %	0.00 %
Primary delay digital filter setting	0 s	0 s	0 s	0 s
Upper limit output limiter/Heating upper limit output limiter	100.0 %	100.0 %	100.0 %	100.0 %

Used to specify as unused the channels where temperature control will not be performed and temperature sensors will not be connected.

2. Click **Clear Value for Gray Cells** to set items unnecessary for the mode set on Switch Setting to 0.

3. Double-click the item to change the setting, and enter the setting value.

- Items to select from a pull-down list
Double-click the item to set to display the pull-down list. Select the item.
- Items to enter in a text box
Double-click the item to set, and enter the value.

Remark

If writing is performed without setting unnecessary items for the mode set on Switch Setting to 0, a write data error (error code: □□□2_H) may occur.

For details on setting values, refer to the following.

Operation mode	Setting item	Reference
Temperature Input Mode	Input range	Page 345, Appendix 2 (12)
	Conversion enable/disable setting	Page 402, Appendix 2 (75)
	Sensor correction value setting	Page 363, Appendix 2 (21)
	Primary delay digital filter setting	Page 365, Appendix 2 (24)
	Process value (PV) scaling function enable/disable setting	Page 405, Appendix 2 (80)
	Process value (PV) scaling lower limit value	Page 406, Appendix 2 (81)
	Process value (PV) scaling upper limit value	
	Cold junction temperature compensation selection	Page 384, Appendix 2 (49)
	Process alarm alert output enable/disable setting	Page 387, Appendix 2 (53)
	Process alarm lower lower limit value	Page 388, Appendix 2 (54)
	Process alarm lower upper limit value	
	Process alarm upper lower limit value	
	Process alarm upper upper limit value	
	Rate alarm alert output enable/disable setting	Page 389, Appendix 2 (55)
	Rate alarm alert detection cycle	Page 389, Appendix 2 (56)
	Rate alarm upper limit value	Page 390, Appendix 2 (57)
	Rate alarm lower limit value	

Operation mode	Setting item	Reference
Temperature control mode	Input range	Page 345, Appendix 2 (12)
	Set value (SV) setting	Page 354, Appendix 2 (14)
	Unused channel setting	Page 376, Appendix 2 (35)
	Proportional band (P) setting/Heating control proportional band setting (Ph)	Page 355, Appendix 2 (15)
	Cooling proportional band (Pc) setting	
	Integral time (I) setting	Page 357, Appendix 2 (16)
	Derivative time (D) setting	Page 357, Appendix 2 (17)
	Control output cycle setting/Heating control output cycle setting	Page 364, Appendix 2 (23)
	Control response parameter	Page 366, Appendix 2 (25)
	Stop Mode Setting	Page 353, Appendix 2 (13)
	PID continuation flag	Page 381, Appendix 2 (43)
	Forward/reverse action setting	Page 371, Appendix 2 (30)
	Upper limit setting limiter	Page 372, Appendix 2 (31)
	Lower limit setting limiter	
	Setting change rate limiter or Setting change rate limiter (Temperature rise)	Page 369, Appendix 2 (28)
	Setting change rate limiter (Temperature drop)	
	Sensor correction value setting	Page 363, Appendix 2 (21)
	Primary delay digital filter setting	Page 365, Appendix 2 (24)
	Upper limit output limiter/Heating upper limit output limiter	Page 360, Appendix 2 (19)
	Lower limit output limiter	
	Output variation limiter	Page 362, Appendix 2 (20)
	Adjustment sensitivity (dead band) setting	Page 363, Appendix 2 (22)
	Self-tuning setting	Page 399, Appendix 2 (72)
	Temperature conversion setting	Page 403, Appendix 2 (76)
	Cooling method setting	Page 404, Appendix 2 (77)
	Cooling upper limit output limiter	Page 360, Appendix 2 (19)
	Cooling control output cycle setting	Page 364, Appendix 2 (23)
	Overlap/dead band setting	Page 404, Appendix 2 (78)
	Process value (PV) scaling function enable/disable setting	Page 405, Appendix 2 (80)
	Process value (PV) scaling lower limit value	Page 406, Appendix 2 (81)
Process value (PV) scaling upper limit value		
Derivative action selection	Page 407, Appendix 2 (83)	

Operation mode	Setting item	Reference
Temperature Control Mode	Simultaneous temperature rise group setting	Page 407, Appendix 2 (84)
	Simultaneous temperature rise AT mode selection	Page 409, Appendix 2 (87)
	Setting change rate limiter Unit time setting	Page 411, Appendix 2 (89)
	Peak current suppression control group setting	Page 412, Appendix 2 (90)
	Automatic backup setting after auto tuning of PID constants	Page 378, Appendix 2 (37)
	Cold junction temperature compensation selection	Page 384, Appendix 2 (49)
	Alert 1 mode setting to Alert 4 mode setting	Page 386, Appendix 2 (52)
	Alert set value 1 to Alert set value 4	Page 358, Appendix 2 (18)
	Alert dead band setting	Page 379, Appendix 2 (38)
	Number of alert delay	Page 379, Appendix 2 (39)
	Loop disconnection detection judgment time	Page 374, Appendix 2 (33)
	Loop disconnection detection dead band	Page 375, Appendix 2 (34)
	Heater disconnection alert setting	Page 373, Appendix 2 (32)
	Heater disconnection/output off-time current error detection delay count	Page 380, Appendix 2 (40)
	Heater disconnection compensation function selection	Page 381, Appendix 2 (44)
	AT Bias	Page 370, Appendix 2 (29)
	Auto tuning mode selection	Page 385, Appendix 2 (51)
	Temperature rise completion range setting	Page 380, Appendix 2 (41)
	Temperature rise completion soak time setting	Page 381, Appendix 2 (42)
	Transistor output monitor ON delay time setting	Page 382, Appendix 2 (45)
	Resolution of the manipulated value for output with another analog module	Page 384, Appendix 2 (48)
	CT monitor method switching	Page 382, Appendix 2 (46)
	CT□ CT input channel assignment setting	Page 391, Appendix 2 (59)
CT□ CT selection	Page 392, Appendix 2 (60)	
CT□ Reference heater current value	Page 393, Appendix 2 (61)	
CT□ CT ratio setting	Page 393, Appendix 2 (62)	

4. When using CH2 to CH4, follow the step 3 described earlier.

7.4 Auto Refresh

Buffer memory data can be transferred to specified devices using this function.
By using this auto refresh setting, reading or writing is not required on a program.

(1) Setting method

Open the "Auto_Refresh" window.

1. Start "Auto_Refresh" on the Project window.

Project window ⇨ [Intelligent Function Module] ⇨ Module name ⇨ [Auto_Refresh]

2. Click the item to set, and enter the auto refresh target device.

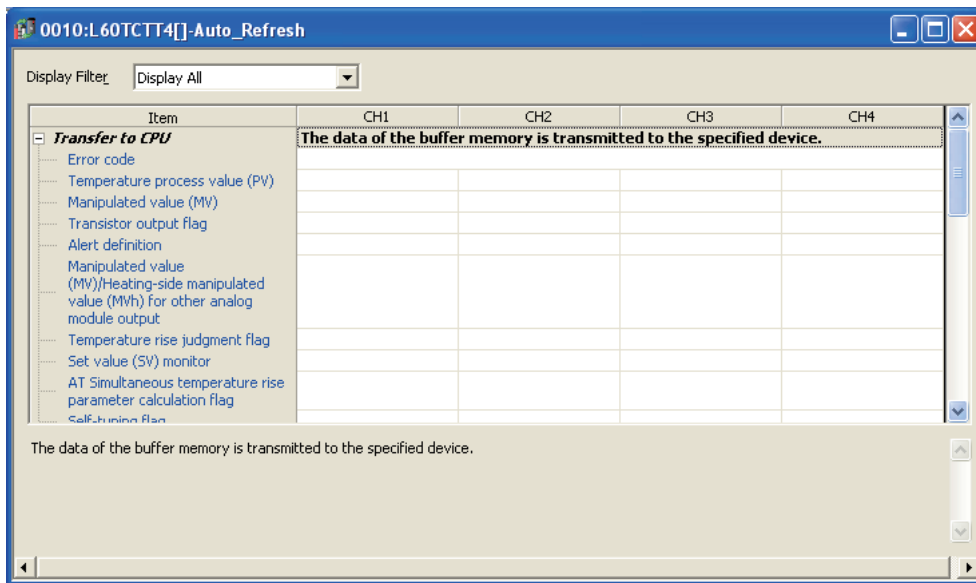

7.5 Auto Tuning

For how to execute auto tuning, refer to the following.

☞ Page 144, Section 8.2.7 (5)

7.6 Sensor Correction

For how to execute sensor correction, refer to the following.

☞ Page 223, Section 8.3.2

CHAPTER 8 FUNCTIONS

This chapter explains the details of the L60TC4 functions and how to set each function.

For details on I/O signals and the buffer memory, refer to the following:

- Details of I/O signals (☞ Page 323, Appendix 1)
- Details of the buffer memory (☞ Page 334, Appendix 2)

Point

For the functions indicated with the icons **Standard** and **Heating-cooling**, or with **Common**, the following terms are used, unless otherwise specified.

- Proportional band (P): includes heating proportional band (Ph) and cooling proportional band (Pc)
 - Manipulated value (MV): includes manipulated value for heating (MVh) and manipulated value for cooling (MVc)
 - Manipulated value (MV) for output with another analog module: includes manipulated value of heating (MVh) for output with another analog module and manipulated value of cooling (MVc) for output with another analog module
 - Transistor output: includes heating transistor output and cooling transistor output
 - Upper limit output limiter value: includes heating upper limit output limiter value and cooling upper limit output limiter value
 - Control output cycle: includes heating control output cycle and cooling control output cycle
-

8.1 Temperature Input Mode

The L60TC4 can be used as a temperature input module using this function.

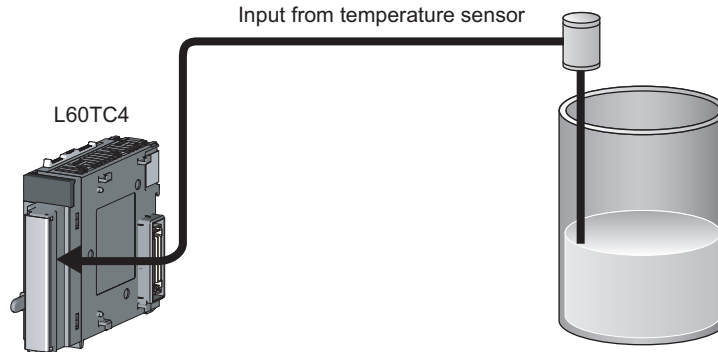

(1) Setting method

Set the L60TC4 to the temperature input mode on Switch Setting. (☞ Page 108, Section 7.2)

☞ Project window ⇒ [Intelligent Function Module] ⇒ Module name ⇒ [Switch Setting]

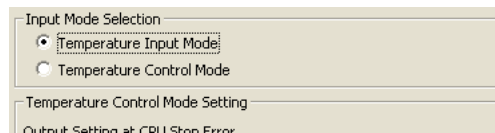

(2) Precaution

When resolution is "1", the temperature process value (PV) of the L60TC4 is rounded off from the actual temperature.

- Ex.** When the actual temperature is 1299.5°C, the temperature process value (PV) of the L60TC4 is 1300°C.
To measure temperature by every 0.1°C, set resolution to "0.1". (☞ Page 345, Appendix 2 (12))
Note that the temperature process value (PV) is not rounded off for the process alarm and rate alarm.
(☞ Page 121, Section 8.1.3 (1) (d), Page 123, Section 8.1.3 (2) (d))

8.1.1 Conversion enable/disable function

Temperature
Input

Temperature conversion can be enabled or disabled for each channel using this function. By disabling unused channels, unnecessary disconnection detection or alert output can be prevented.

(1) Setting method

Set "Conversion enable/disable setting" to "0: Enable".

 Project window ⇨ [Intelligent Function Module] ⇨ Module name ⇨ [Parameter]

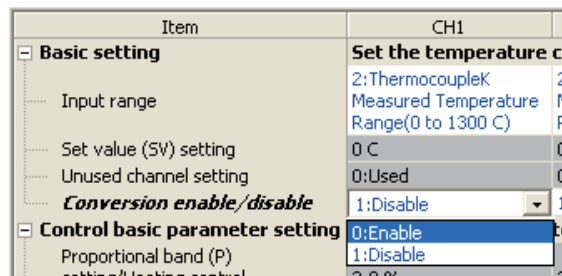

8.1.2 Temperature conversion method

Temperature
Input

8

In the L60TC4, a measured value is stored into CH□ Temperature process value (PV) (Un\G9 to Un\G12) in every sampling cycle. In addition, the use of the primary delay digital filter smoothens the temperature process value (PV), and its drastic change can be absorbed.

(1) Sampling cycle

A sampling cycle can be selected from 250ms or 500ms.

(a) How to set the sampling cycle

Select a sampling cycle on "Sampling Cycle Selection".

 Project window ⇨ [Intelligent Function Module] ⇨ Module name ⇨ [Switch Setting]

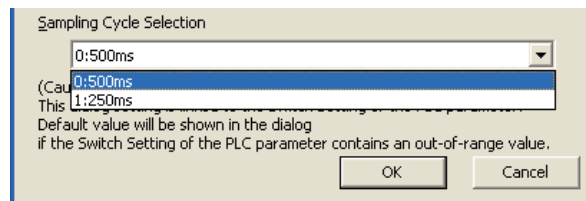

(b) How to check the sampling cycle

The selected sampling cycle can be checked in Sampling cycle monitor (Un\G788).

(2) Primary delay digital filter

The primary delay digital filter smoothens extreme noise before outputting the temperature process value (PV).

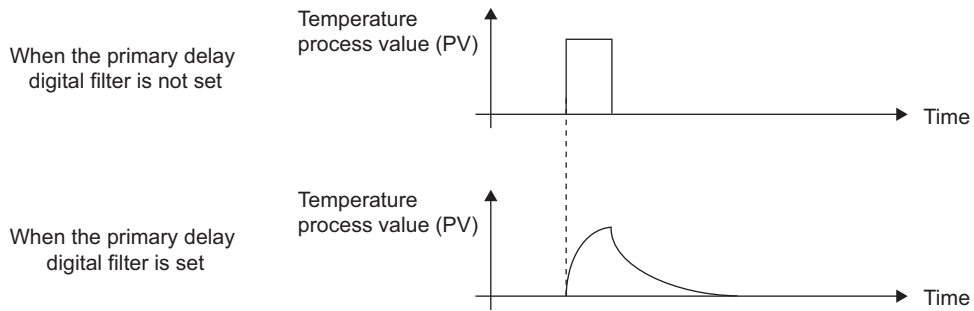

For the primary delay digital filter, set the time until the temperature process value (PV) changes by 63.3% (time constant).

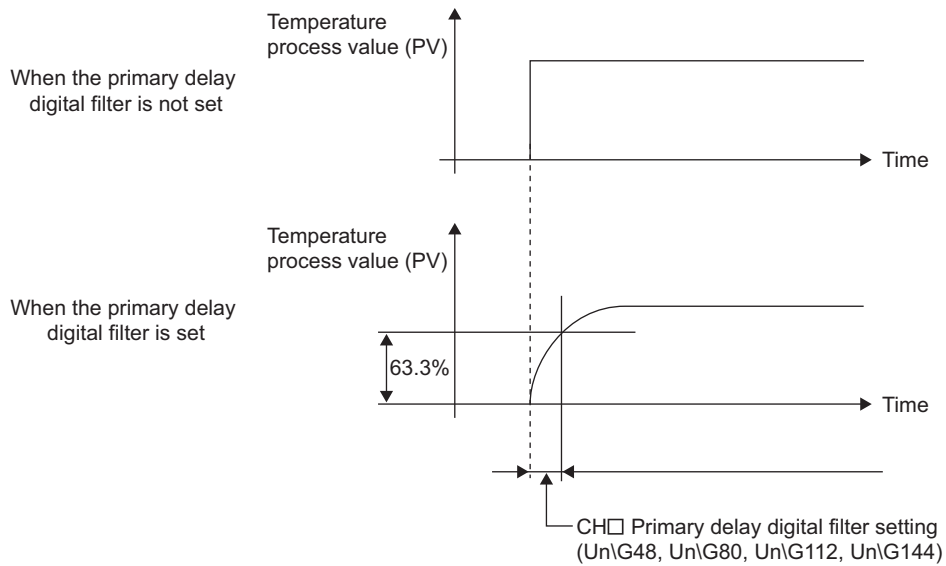

(a) How to set the primary digital filter

In "Primary delay digital filter setting", set the time until the temperature process value (PV) changes by 63.3% (time constant).

🔍 Project window ⇨ [Intelligent Function Module] ⇨ Module name ⇨ [Parameter]

Item	CH1
Control detail parameter setting	The Q64TCTT(BW) allow meet the operating te
Forward/reverse action setting	1:Reverse Action
Upper limit setting limiter	1300 C
Lower limit setting limiter	0 C
Setting change rate limiter or (Temperature rise)	0.0 %
Setting change rate limiter (Temperature drop)	0.0 %
Sensor correction value setting	0.00 %
Primary delay digital filter	3 s
Upper limit output limiter/Setting	

Ex. When 3(3s) is set in "Primary delay digital filter setting"

The change shown below will happen if the Temperature process value (PV) changes from 250°C to 260°C under the condition where 3(3s) is set in "Primary delay digital filter setting".

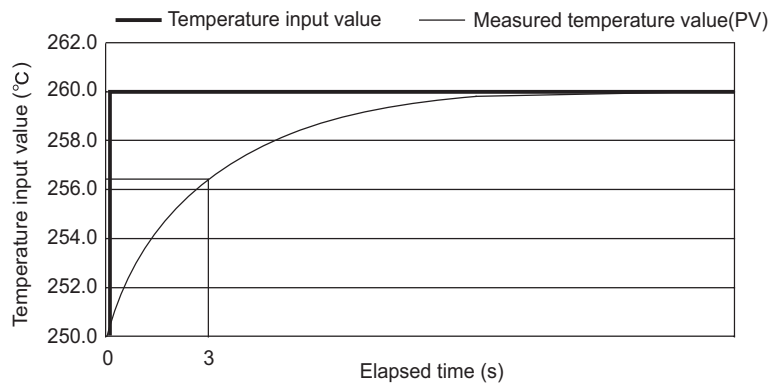

The temperature reaches 256.3°C which is 63.3% of the temperature process value (PV) three seconds after the temperature input value reached 260.0°C.

8.1.3 Alert output function

An alert can be output when the temperature process value (PV) meets the condition set in advance using this function. Use this function to activate danger signals of devices or safety devices.

There are two types of alert: process alarm and rate alarm.

(1) Process alarm

An alert occurs when the temperature process value (PV) reaches the process alarm upper upper limit value or more, or the process alarm lower lower limit value or less.

The alert is cleared when the process value reaches a value less than the process alarm upper lower limit value, or a value more than the process alarm lower upper limit value. An alert is not cleared even by resetting the error or switching to the setting mode.

(a) Checking the alert occurrence

When an alert occurs, CH□ Alert occurrence flag (XnC to XnF) turns on, and the ALM LED turns on.

In CH□ Alert definition (Un\G5 to Un\G8), whether it is an upper limit alert or lower limit alert can be checked.

(☞ Page 336, Appendix 2 (3))

(b) Checking the alert clearance

CH□ Process alarm upper limit (b2 of Un\G5 to Un\G8) or CH□ Process alarm lower limit (b3 of Un\G5 to Un\G8) becomes 0 (OFF). Also, CH□ Alert occurrence flag (XnC to XnF) turns off, and the ALM LED turns off.

Point

In CH□ Alert occurrence flag (XnC to XnF) and on the ALM LED, the alert is not cleared when an alert other than the process alarm is occurring.

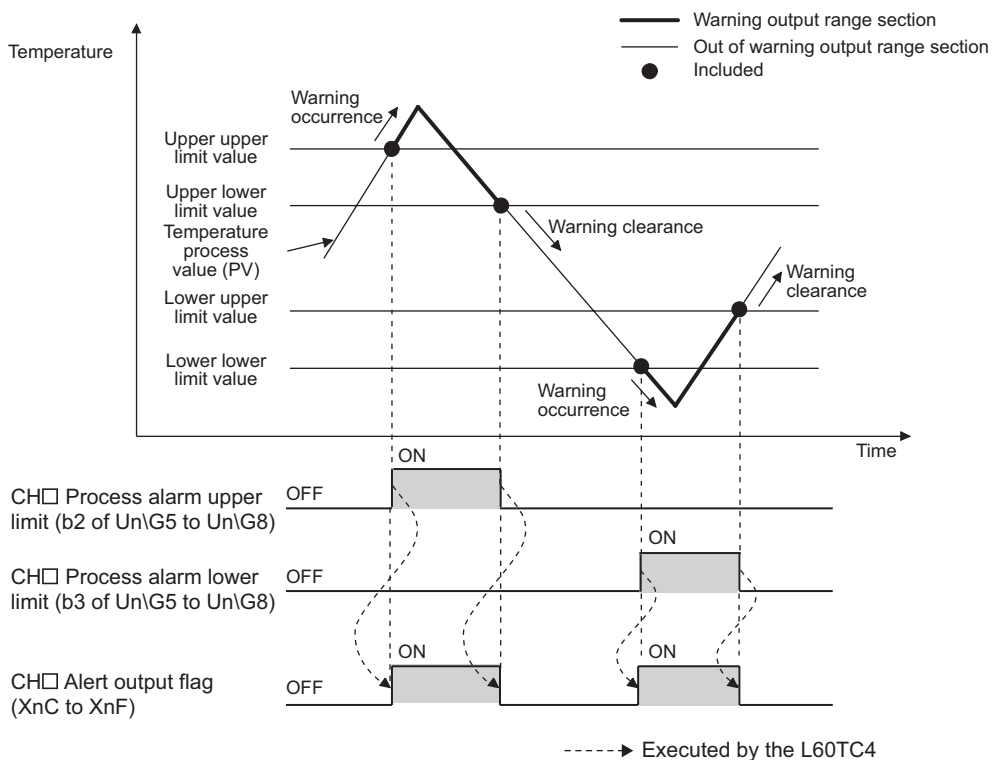

(c) How to set process alarm

Set "Process alarm alert output enable/disable setting" to "0: Enable". Then, set the lower lower limit value, lower upper limit value, upper lower limit value, and upper upper limit value of the process alarm.

 Project window ⇨ [Intelligent Function Module] ⇨ Module name ⇨ [Parameter]

Item	CH1	
Process alarm alert output enable/disable setting	0:Enable	0
Process alarm lower lower limit value	0 C	0
Process alarm lower upper limit value	100 C	1
Process alarm upper lower limit value	900 C	9
Process alarm upper upper limit value	1000 C	1

(d) Precaution

When resolution is "1", the temperature process value (PV) of the L60TC4 is rounded off from the actual temperature. For the process alarm also, the temperature process value (PV) rounded off from the actual temperature determines the alert occurrence.

(2) Rate alarm

The temperature process value (PV) is monitored every rate alarm alert detection cycle. An alert occurs when the change from the previous monitoring is greater than the rate alarm upper limit value, or smaller than the rate alarm lower limit value. The rate alarm is helpful to monitor the change of the temperature process value (PV) in a limited range.

$$\begin{aligned} & \text{PV Present value} - \text{PV Previous value} \geq \text{Rate alarm upper limit value} \\ & \text{PV Present value} - \text{PV Previous value} \leq \text{Rate alarm lower limit value} \end{aligned}$$

The alert is cleared when the temperature process value reaches within the range of the formulas above. An alert is not cleared even by resetting the error or switching to the setting mode.

(a) Checking the alert occurrence

While the rate alarm is occurring, CH□ Alert occurrence flag (XnC to XnF) turns on, and the ALM LED turns on.^{*1}

In CH□ Alert definition (Un\G5 to Un\G8), whether it is an upper limit alert or lower limit alert can be checked.

( Page 336, Appendix 2 (3))

^{*1} The ALM LED prioritizes the detection of other errors for which the ALM LED flashes (such as the detection of loop disconnection).

(b) Checking the alert clearance

CH□ Rate alarm upper limit (b4 of Un\G5 to Un\G8) or CH□ Rate alarm lower limit (b5 of Un\G5 to Un\G8) becomes 0 (OFF). Also, CH□ Alert occurrence flag (XnC to XnF) turns off, and the ALM LED turns off.

Point

In CH□ Alert occurrence flag (XnC to XnF) and on the ALM LED, the alert is not cleared when an alert other than the rate alarm is occurring.

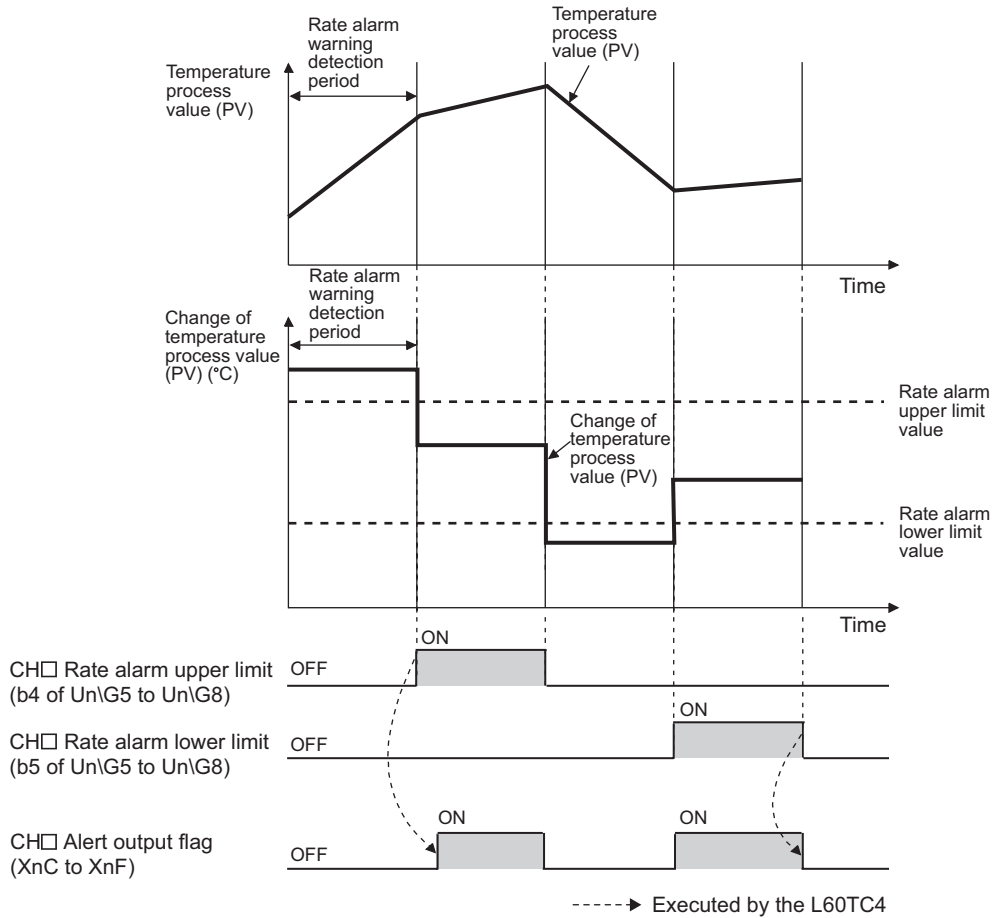

(c) How to set rate alarm

Set "Rate alarm alert output enable/disable setting" to "0: Enable". Then, set the alert detection cycle, upper limit value, and lower limit value of the rate alarm.

Project window ⇨ [Intelligent Function Module] ⇨ Module name ⇨ [Parameter]

Item	CH1
Rate alarm alert output enable/disable setting	0:Enable
Rate alarm alert detection cycle	1 Times
Rate alarm upper limit value	200 C
Rate alarm lower limit value	10 C

(d) Precaution

When resolution is "1", the temperature process value (PV) of the L60TC4 is rounded off from the actual temperature. For the rate alarm also, the temperature process value (PV) rounded off from the actual temperature determines the alert occurrence.

Ex. A setting example of the rate alarm upper limit value and lower limit value to monitor that the temperature process value (PV) is rising within the specified range

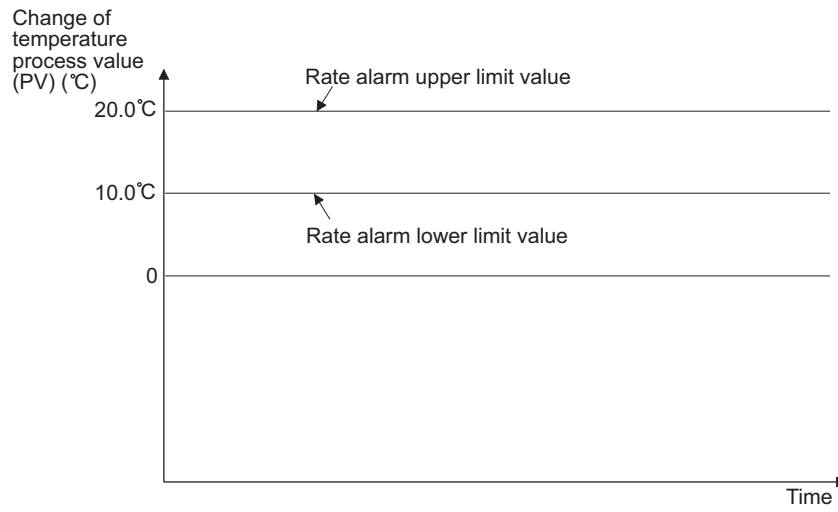

Ex. A setting example of the rate alarm upper limit value and lower limit value to monitor that the temperature process value (PV) is falling within the specified range

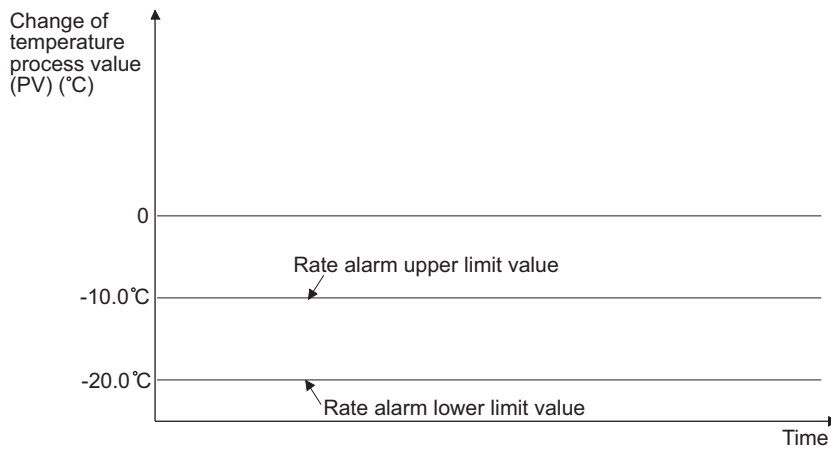

Ex. A setting example of the rate alarm upper limit value and lower limit value to monitor that the temperature process value (PV) is changing within the specified range

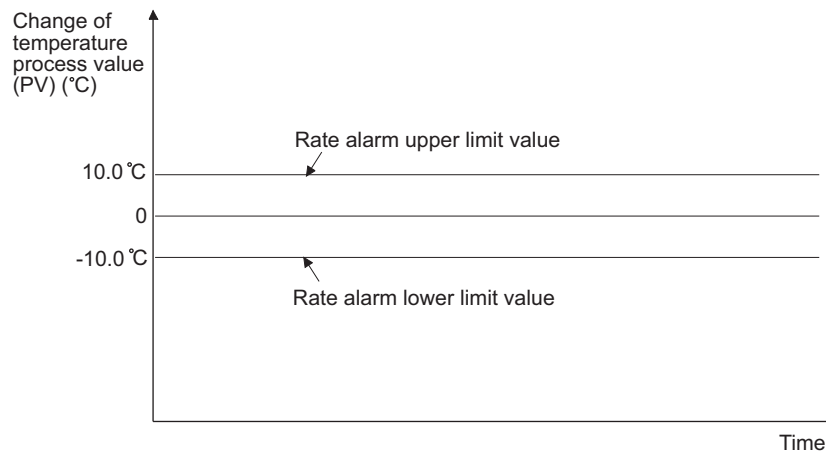

8.2 Temperature Control Mode

The L60TC4 can be used as a temperature control module using this function.

- Standard control (heating)

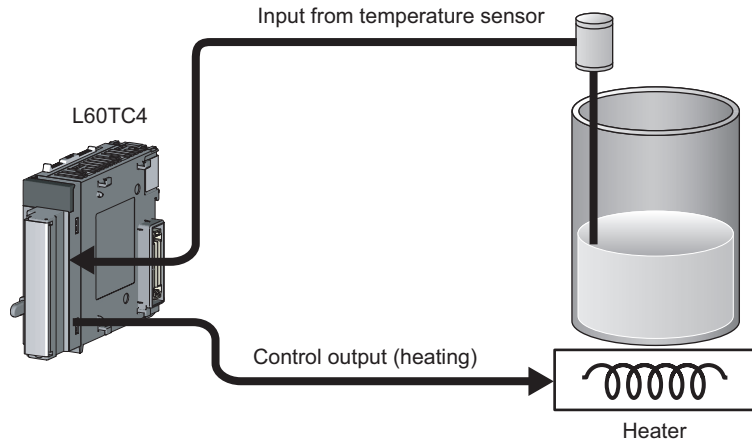

- Heating-cooling control (heating and cooling)

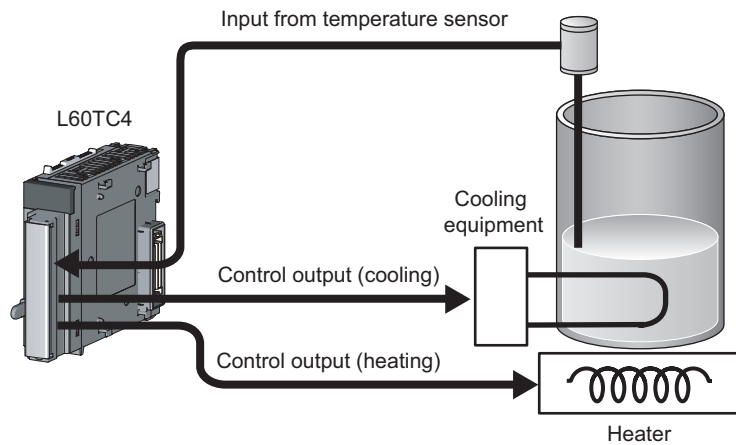

(1) Setting method

Set the L60TC4 to the temperature control mode on Switch Setting. (☞ Page 108, Section 7.2)

☞ Project window ⇨ [Intelligent Function Module] ⇨ Module name ⇨ [Switch Setting]

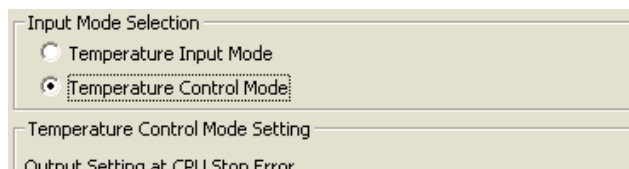

8.2.1 Control Mode Selection Function

Standard Heating-cooling

A control mode can be selected using this function.

This section explains selectable control modes of the L60TC4.

(1) Standard control and heating-cooling control

There are two types of control modes in the L60TC4: standard control and heating-cooling control.

(a) Standard control

The control method is either one of heating (reverse action) or cooling (forward action). When the control method is heating, of a heater for example, cooling is controlled by simply turning off the heating. When the control method is cooling, of cold water for example, heating is controlled by simply turning off the cooling.

(b) Heating-cooling control

The control method is both heating and cooling. To heat up the target subject, its heating mean is turned on, and its cooling mean is turned off. To cool down the target subject, its heating mean is turned off, and its cooling mean is turned on.

(2) Selectable control mode

A control mode can be selected from five modes.

Select the control mode on Switch Setting.

For details on the setting method, refer to the following.

 Page 108, Section 7.2

Control mode	Contents	Number of controllable loops
Standard control	Performs the standard control of four channels	Standard control 4 loops
Heating-cooling control (normal mode)	Performs the heating-cooling control. CH3 and CH4 cannot be used.	Heating-cooling control 2 loops
Heating-cooling control (expanded mode)	Performs the heating-cooling control. The number of loops is expanded using an output module and others in the system.	Heating-cooling control 4 loops
Mix control (normal mode)	Performs the standard control and the heating-cooling control. CH2 cannot be used.	Standard control 2 loops Heating-cooling control 1 loop
Mix control (expanded mode)	Performs the standard control and the heating-cooling control. The number of loops is expanded using an output module and others in the system.	Standard control 2 loops Heating-cooling control 2 loops

Control for each channel is as follows.

Channel	Standard control	Heating-cooling control		Mix control	
		Normal mode	Expanded mode	Normal mode	Expanded mode
CH1	Standard control	Heating-cooling control	Heating-cooling control	Heating-cooling control	Heating-cooling control
CH2	Standard control	Heating-cooling control	Heating-cooling control	—*1	Heating-cooling control*2
CH3	Standard control	—*1	Heating-cooling control*2	Standard control	Standard control
CH4	Standard control	—*1	Heating-cooling control*2	Standard control	Standard control

*1 Only temperature measurement using a temperature input terminal can be performed. ( Page 212, Section 8.2.23)

*2 Heating-cooling control is performed using an output module in the system. ( Page 127, Section 8.2.1 (3))

(3) Expanded mode

In the heating-cooling control (expanded mode) or the mix control (expanded mode), the number of loops for heating-cooling control can be expanded using an output module and others in the system. To use an expanded mode, construct a system such as the one shown below.

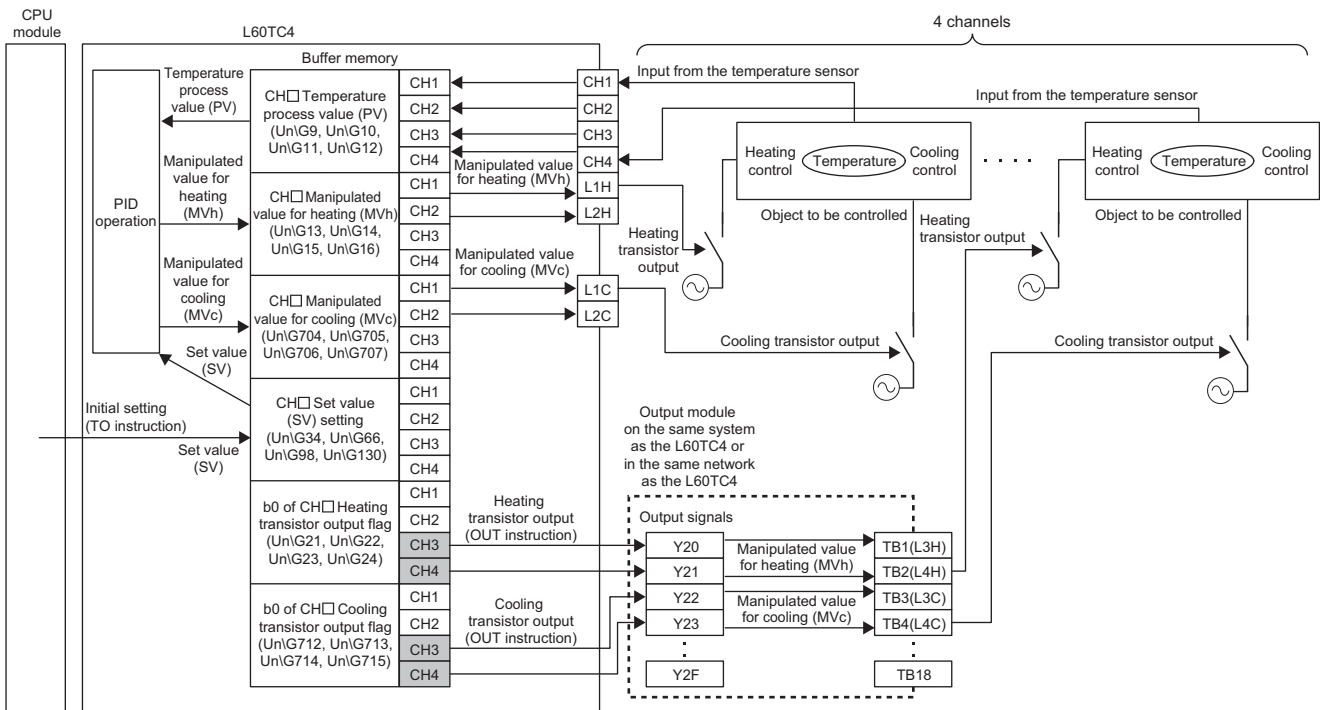

Point

When the heating-cooling control (expanded mode) is selected, heating/cooling transistor output of CH3 and CH4 are activated. Also, when the mix control (expanded mode) is selected, heating/cooling transistor output of CH2 is activated. These areas are activated only when an expanded mode is selected. When a normal mode is selected, these areas are used for the system. If data is written into these areas when it is used by the system, a write data error occurs. (error code: □□□2_H)

The following is an example of using an expanded mode.

Ex. A program in which CH3 Heating transistor output flag (b0 of Un\G23) is assigned to Y20 of an output module (The start I/O number of the L60TC4 is set to 10 in the following program example.)



8.2.2 Control output setting at CPU stop error

Standard Heating-cooling

When a stop error occurs on the CPU module or when CPU's status is changed from RUN to STOP, whether to hold or clear the status of transistor output can be selected using this function.

Configure "Output Setting at CPU Stop Error" on Switch Setting.

For details on the setting method, refer to the following.

 Page 108, Section 7.2

Processing for each status is describes in the following table.

Status		Processing				Reference
Output Setting at CPU Stop Error		CLEAR		HOLD		Page 108, Section 7.2
Setting of PID continuation flag (Un\G169)		Stop	Continue	Stop	Continue	Page 381, Appendix 2 (43)
Error	L60TC4 Write data error	Follow the operation of when an error occurs				Page 315, Section 11.6
	L60TC4 Hardware error	Depends on the symptom of the hardware				—
	CPU Stop error	Stops the operation and turns off external output		Follows the stop mode setting ^{*1}	Stops the operation and performs external output	—
CPU operation	RUN → STOP	Follows the stop mode setting ^{*1}	Stops the operation and performs external output	Follows the stop mode setting ^{*1}	Stops the operation and performs external output	—
	Resetting	The module is incapable to operate, and not performs external output				—

*1 CH□ Stop mode setting (Un\G33, Un\G65, Un\G97, Un\G129) ( Page 353, Appendix 2 (13))

Important

- Fully pay attention to the setting of PID continuation flag (Un\G169) which controls external output.
- By the failure of an output element or internal circuit, an abnormal output may occur. Construct a circuit to monitor output signals that could cause a serious accident.

8.2.3 Control method

Standard Heating-cooling

The following control methods can be applied by setting the proportional band (P), integral time, and derivative time(D).

- Two-position control (☞ Page 129, Section 8.2.3 (1))
- P control (☞ Page 131, Section 8.2.3 (2))
- PI control (☞ Page 132, Section 8.2.3 (3))
- PD control (☞ Page 133, Section 8.2.3 (4))
- PID control (☞ Page 133, Section 8.2.3 (5))

Remark

For P control and PD control, the manual reset function is activated. (☞ Page 137, Section 8.2.4)

(1) Two-position control

Two-position control is a control method that uses 0% manipulated value (MV) and 100% manipulated value (MV). Turning on and off the manipulated value (MV) repeatedly, the temperature process value comes close to the set value (SV), then is kept constant.

Point

By the setting in CH Adjustment sensitivity (dead band) setting (UnG46, UnG78, UnG110, UnG142) the chattering of transistor output under two-position control can be prevented. Set a dead band toward the set value (SV) in CH Adjustment sensitivity (dead band) setting (UnG46, UnG78, UnG110, UnG142). (☞ Page 363, Appendix 2 (22))

(a) Standard control

The module operates as follows outside the range of CH Adjustment sensitivity (dead band) setting (UnG46, UnG78, UnG110, UnG142).

Condition	Transistor output status
The temperature process value (PV) is below the lower limit of the adjustment sensitivity (dead band).	ON
The temperature process value (PV) is above the upper limit of the adjustment sensitivity (dead band).	OFF

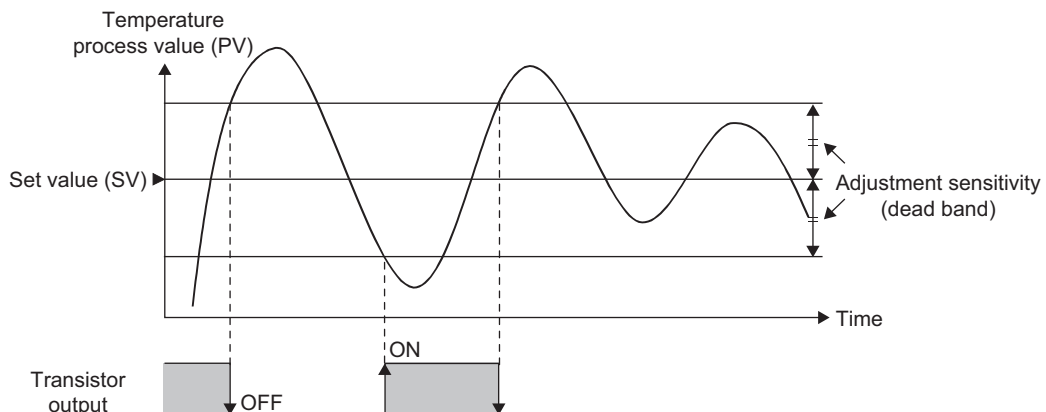

(b) Heating-cooling control

The module operates as follows outside the range of CH□ Adjustment sensitivity (dead band) setting (Un\G46, Un\G78, Un\G110, Un\G142).

Condition	Heating transistor output status	Cooling transistor output status
The temperature process value (PV) is below the lower limit of the adjustment sensitivity (dead band).	ON	OFF
The temperature process value (PV) is above the upper limit of the adjustment sensitivity (dead band).	OFF	ON

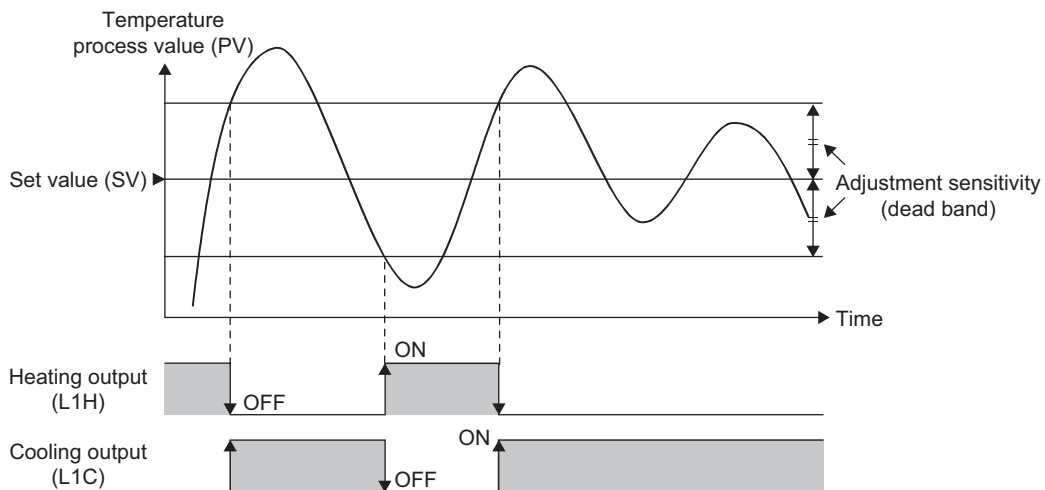

(c) Three-position control

Three-position control can also be performed by setting a dead band.

For more details, refer to the following.

Page 211, Section 8.2.22 (3)

(d) Setting method

Set "Proportional band (P) setting/Heating control proportional band setting (Ph)" to 0.0%.

Project window ⇨ [Intelligent Function Module] ⇨ Module name ⇨ [Parameter]

Item	CH1
Control basic parameter setting	The Q64TC exercises temperature adjust
Proportional band (P) setting/Heating control proportional band setting	0.0 %
Cooling proportional band (Pc) setting	3.0 %
Integral time (I) setting	240 s
Derivative time (D) setting	60 s
Control output cycle setting/Heating control output	30 s

(2) P Control

P control is a control method in which the manipulated value (MV) is determined proportional to the deviation (E) between the temperature process value (PV) and set value (SV).

(a) Standard control

The manipulated value is 50% in the following conditions.

- Temperature process value (PV) = Set value (SV)
- CH□ Manual reset amount setting (Un\G724, Un\G740, Un\G756, Un\G772) is set to 0 (0.0%).

(☞ Page 405, Appendix 2 (79))

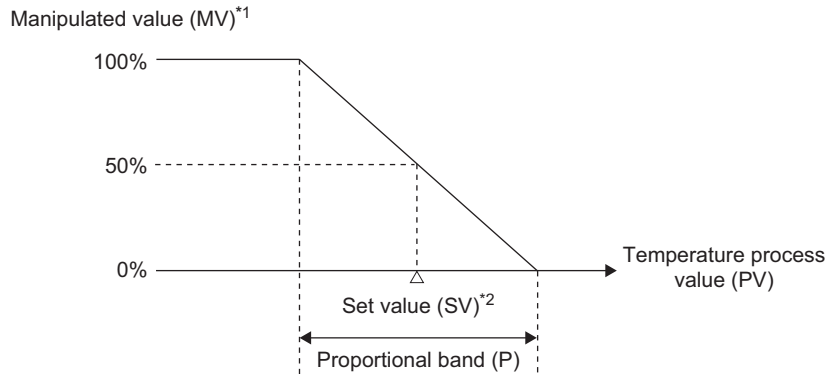

*1 The value actually output is within the output limiter range set in CH□ Output variation limiter setting (Un\G44, Un\G76, Un\G108, Un\G140). (☞ Page 362, Appendix 2 (20))

*2 The set value (SV) is in the center of the proportional band.

(b) Heating-cooling control

The manipulated value for heating (MVh) and the manipulated value for cooling (MVc) are both 0% in the following conditions.

- Temperature process value (PV) = Set value (SV)
- CH□ Manual reset amount setting (Un\G724, Un\G740, Un\G756, Un\G772) is set to 0 (0.0%).

(☞ Page 405, Appendix 2 (79))

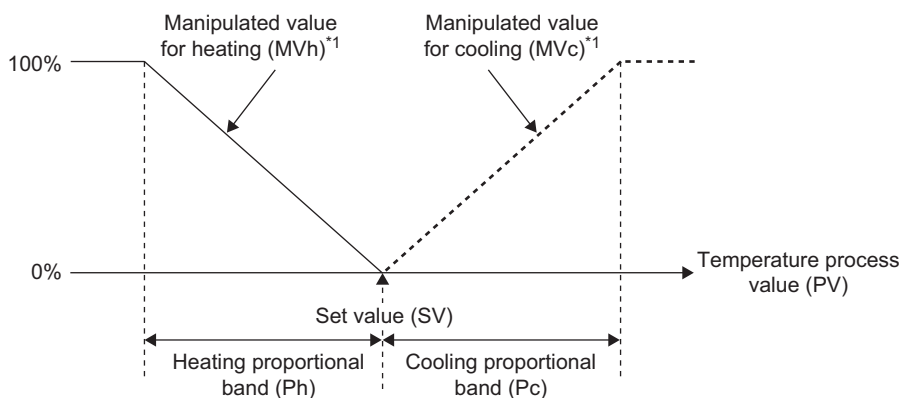

*1 The value actually output is within the output limiter range set in CH□ Output variation limiter setting (Un\G44, Un\G76, Un\G108, Un\G140). (☞ Page 362, Appendix 2 (20))

(c) Setting method

Set each item as follows.

- "Proportional band (P) setting/Heating control proportional band setting (Ph)" : any value
- "Integral time (I) setting": 0s
- "Derivative time (D) setting": 0s

 Project window ⇨ [Intelligent Function Module] ⇨ Module name ⇨ [Parameter]

Item	CH1	
Control basic parameter setting	The Q64TC exercises temperature adjust	
Proportional band (P) setting/Heating control proportional band setting (Ph)	3.0 %	3
Cooling proportional band (Pc) setting	3.0 %	3
Integral time (I) setting	0 s	2
Derivative time (D) setting	0 s	6

(3) PI Control

PI control is a control method in which integral elements are added to P control, and an offset (remaining deviation) is compensated. By setting the integral time (I) properly, the temperature process value (PV) and the set value (SV) can be met.

PI control is a control method in which integral elements are added to P control, thereby an offset (remaining deviation) is compensated. By setting the integral time (I) properly, the temperature process value (PV) matches with the set value (SV)

(a) Setting method

Set each item as follows.

- "Proportional band (P) setting/Heating control proportional band setting (Ph)" : any value
- "Integral time (I) setting": any value
- "Derivative time (D) setting": 0s

 Project window ⇨ [Intelligent Function Module] ⇨ Module name ⇨ [Parameter]

Item	CH1	
Control basic parameter setting	The Q64TC exercises temperature adjust	
Proportional band (P) setting/Heating control proportional band setting (Ph)	3.0 %	
Cooling proportional band (Pc) setting	3.0 %	
Integral time (I) setting	240 s	
Derivative time (D) setting	0 s	
Control output cycle setting/Heating control output cycle setting.	30 s	

(4) PD Control

PD control is a control method in which the derivative time (D) is set in addition to PD control. The control mechanism is the same as P control.

(a) Setting method

Set each item as follows.

- "Proportional band (P) setting/Heating control proportional band setting (Ph)" : any value
- "Integral time (I) setting": 0s
- "Derivative time (D) setting": any value

 Project window ⇨ [Intelligent Function Module] ⇨ Module name ⇨ [Parameter]

Item	CH1
Control basic parameter setting	The Q64TC exercises temperature adjust
Proportional band (P) setting/Heating control proportional band setting (Ph)	3.0 %
Cooling proportional band (Pc) setting	3.0 %
Integral time (I) setting	0 s
Derivative time (D) setting	60 s

(5) PID Control

PID control is a control method in which derivative elements are added to PI control, thereby the temperature shifts to a stable status in a short period of time even when a drastic change has occurred. By setting the derivative time (D) properly, the control subject shifts to a stable status in a short period of time.

(a) Setting method

Set any value to "Proportional band (P) setting/Heating control proportional band setting (Ph)", "Integral time (I) setting", and "Derivative time (D) setting".

 Project window ⇨ [Intelligent Function Module] ⇨ Module name ⇨ [Parameter]

Item	CH1
Control basic parameter setting	The Q64TC exercises temperature adjust
Proportional band (P) setting/Heating control proportional band setting (Ph)	3.0 %
Cooling proportional band (Pc) setting	3.0 %
Integral time (I) setting	240 s
Derivative time (D) setting	60 s

(6) Condition to perform PID control

The condition to be able to perform PID control*¹ depends on the settings of the followings.

- Setting/operation mode instruction (Yn1) (☞ Page 330, Appendix 1.2 (1))
- PID continuation flag (Un\G169) (☞ Page 381, Appendix 2 (43))
- CH□ PID control forced stop instruction (YnC to YnF) (☞ Page 333, Appendix 1.2 (7))
- CH□ Stop mode setting (Un\G33, Un\G65, Un\G97, Un\G129) (☞ Page 353, Appendix 2 (13))

The following table shows the relationship between the status of PID control*¹ and each of the settings above.

○: Performed ×: Not performed

Setting/operation mode instruction (Yn1)* ²	PID continuation flag (Un\G169)	CH□ PID control forced stop instruction (YnC to YnF)	CH□ Stop mode setting (Un\G33, Un\G65, Un\G97, Un\G129)	Control status of PID control* ¹
Setting mode at power-ON	Stop (0)/Continue (1)	OFF/ON	Stop (0)/Monitor (1)/Alert (2)	×
Operation mode (operating)	Stop (0)/Continue (1)	OFF	Stop (0)/Monitor (1)/Alert (2)	○
		ON	Stop (0)/Monitor (1)/Alert (2)	×
Setting mode (after operation)	Stop (0)	OFF/ON	Stop (0)/Monitor (1)/Alert (2)	×
	Continue (1)	OFF	Stop (0)/Monitor (1)/Alert (2)	○
		ON	Stop (0)/Monitor (1)/Alert (2)	×

*¹ Here, this is the generic term for two-position control, P control, PI control, PD control, and PID control.

*² For the timing of each, refer to ☞ Page 324, Appendix 1.1 (2)

Even though the conditions above are met, PID control is not performed when CH□ Unused channel setting (Un\G61, Un\G93, Un\G125, Un\G157) is set to Unused (1). (☞ Page 376, Appendix 2 (35))

Point

The manipulated value (MV) and manipulated value (MV) for output with another analog module of when CH□ PID control forced stop instruction (YnC to YnF) is turned on from off are as follows.

Buffer memory area name	Buffer memory address				Stored value	Reference
	CH1	CH2	CH3	CH4		
CH□ Manipulated value (MV)	Un\G13	Un\G14	Un\G15	Un\G16	-50 (-5.0%)	Page 339, Appendix 2 (5)
CH□ Manipulated value (MV) for output with another analog module	Un\G177	Un\G178	Un\G179	Un\G180	0	Page 383, Appendix 2 (47)
CH□ Manipulated value for heating (MVh) (Un\G13 to Un\G16)	Un\G13	Un\G14	Un\G15	Un\G16	-50 (-5.0%)	Page 339, Appendix 2 (5)
CH□ Manipulated value of heating (MVh) for output with another analog module	Un\G177	Un\G178	Un\G179	Un\G180	0	Page 383, Appendix 2 (47)
CH□ Manipulated value for cooling (MVc)	Un\G704	Un\G705	Un\G706	Un\G707	-50 (-5.0%)	Page 339, Appendix 2 (5)
CH□ Manipulated value of cooling (MVc) for output with another analog module	Un\G708	Un\G709	Un\G710	Un\G711	0	Page 383, Appendix 2 (47)

When CH□ PID control forced stop instruction (YnC to YnF) is turned off from on, the forced stop of PID control is released. PID operation resumes with the manipulated value (MV) which was being output when the PID control was forcibly stopped.

(7) Buffer memory areas related to control method

The following table shows the buffer memory areas related to control method.

Buffer memory area name	Buffer memory address				Setting range					Reference
	CH1	CH2	CH3	CH4	Two-position control	P control	PD control	PI control	PID control	
CH□ Input range	Un\G32	Un\G64	Un\G96	Un\G128	Thermocouple: 1 to 4, 11 to 28, 36 to 48, 49 to 52, 100 to 117, 130 to 132, 201 to 205 Platinum resistance thermometer: 5 to 8, 53, 54, 140 to 143, 201 to 205					Page 345, Appendix 2 (12)
CH□ Set value (SV) setting	Un\G34	Un\G66	Un\G98	Un\G130	Set a value within the temperature measurement range of the set input range					Page 354, Appendix 2 (14)
CH□ Proportional band (P) setting	Un\G35	Un\G67	Un\G99	Un\G131	Fix the setting to 0.	Configure the setting in the range from 0 to 10000 (0.0% to 1000.0%) toward the full scale of the set input range.				Page 355, Appendix 2 (15)
CH□ Heating proportional band (Ph) setting	Un\G35	Un\G67	Un\G99	Un\G131						
CH□ Cooling proportional band (Pc) setting	Un\G720	Un\G736	Un\G752	Un\G768	The setting is ignored*1	Configure the setting in the range from 1 to 10000 (0.1% to 1000.0%) toward the full scale of the set input range.				
CH□ Integral time (I) setting	Un\G36	Un\G68	Un\G100	Un\G132	The setting is ignored*1	Fix the setting to 0.	Fix the setting to 0.	1 to 3600 (s)	1 to 3600 (s)	Page 357, Appendix 2 (16)
CH□ Derivative time (D) setting	Un\G37	Un\G69	Un\G101	Un\G133	The setting is ignored*1	Fix the setting to 0.	1 to 3600 (s)	Fix the setting to 0.	1 to 3600 (s)	Page 357, Appendix 2 (17)
CH□ Upper limit output limiter	Un\G42	Un\G74,	Un\G106	Un\G138	The setting is ignored*1	-50 to 1050 (-5.0% to 105.0%)				Page 360, Appendix 2 (19)
CH□ Lower limit output limiter	Un\G43	Un\G75	Un\G107	Un\G139						
CH□ Heating upper limit output limiter	Un\G42	Un\G74	Un\G106	Un\G138		0 to 1050 (0.0% to 105.0%)				
CH□ Cooling upper limit output limiter	Un\G721	Un\G737	Un\G753	Un\G769						
CH□ Output variation limiter setting	Un\G44	Un\G76	Un\G108	Un\G140	The setting is ignored*1	1 to 1000 (0.1%/s to 100.0%/s)				Page 362, Appendix 2 (20)
CH□ Adjustment sensitivity (dead band) setting	Un\G46	Un\G78	Un\G110	Un\G142	Configure the setting in the range from 1 to 100 (0.1% to 10.0%) toward the full scale of the set input range.	The setting is ignored*1				Page 363, Appendix 2 (22)

Buffer memory area name	Buffer memory address				Setting range					Reference
	CH1	CH2	CH3	CH4	Two-position control	P control	PD control	PI control	PID control	
CH□ Control output cycle setting	Un\G47	Un\G79	Un\G111	Un\G143	The setting is ignored*1	<ul style="list-style-type: none"> • The control output cycle unit selection setting on Switch Setting is 1s: 1 to 100 (1s to 100s) • The control output cycle unit selection setting on Switch Setting is 0.1s: 5 to 1000 (0.5s to 100.0s) 				Page 364, Appendix 2 (23)
CH□ Heating control output cycle setting	Un\G47	Un\G79	Un\G111	Un\G143						
CH□ Cooling control output cycle setting	Un\G722	Un\G738	Un\G754	Un\G770						
CH□ Overlap/dead band setting	Un\G723	Un\G739	Un\G755	Un\G771	Configure the setting in the range from -100 to 100 (-10.0% to 10.0%) toward the full scale of the set input range.					Page 404, Appendix 2 (78)
CH□ Manual reset amount setting	Un\G724	Un\G740	Un\G756	Un\G772	The setting is ignored*1	Configure the setting in the range from -1000 to 1000 (-100.0 to 100.0%) toward the full scale of the set input range.		The setting is ignored*1		Page 405, Appendix 2 (79)

*1 When outside the setting range, a write data error (error code: □□□4_h) occurs.

Point

The L60TC4 automatically sets optimum PID constants if the following functions are used.

- Auto tuning function ( Page 141, Section 8.2.7)
- Self-tuning function ( Page 175, Section 8.2.15)

8.2.4 Manual Reset Function

Standard Heating-cooling

The position of the stable condition in P control or PD control can be shifted manually using this function.

By shifting the proportional band (P), an offset (remaining deviation) is manually reset.

The offset is reset by determining and setting the amount to shift the value of the manipulated value (MV) in a stable condition from the reference value.

The reference value is 50% for standard control, and 0% for heating-cooling control.

Point

This function can be active only in P control and PD control. This function is inactive when integral time (I) is other than 0. CH□ Manual reset amount setting (Un\G724, Un\G740, Un\G756, Un\G772) is ignored even if it is set. (Note that a write data error (error code: □□□4_H) occurs if it is outside the setting range.)

(1) Standard control

The set value (SV) is set where the manipulated value (MV) is 50%. Due to this, as long as the temperature process value (PV) and the set value (SV) is not in equilibrium at 50% of manipulated value, an offset (remaining deviation) generates.

When an offset generates, the proportional band (P) can be manually shifted by the amount of the offset (remaining deviation).

Ex. When using the manual reset function in the following conditions

- Control method: P control
- CH□ Manual reset amount setting (Un\G724, Un\G740, Un\G756, Un\G772): 300 (30%)
The L60TC4 shifts the manipulated value (MV) by which the temperature is stabilized at the set value (SV) from 50% to 80%.

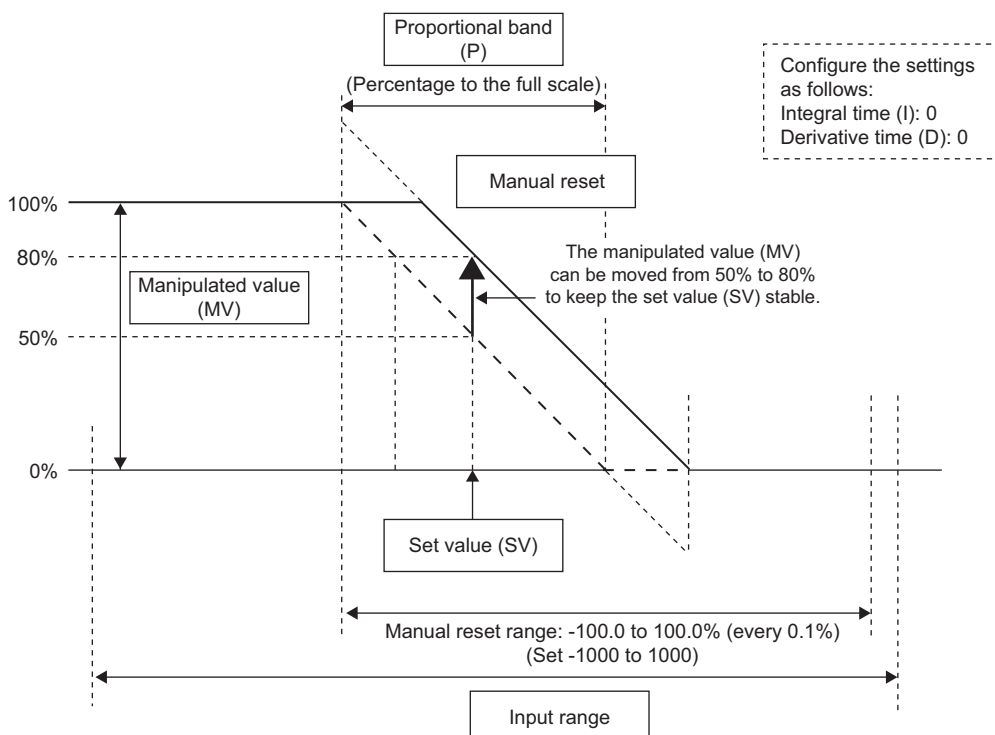

(2) Heating-cooling control

The set value (SV) is set where the manipulated value for heating (MVh)/manipulated value for cooling (MVc) is 0%. Due to this, as long as the temperature process value (PV) and the set value (SV) is not in equilibrium at 0% of manipulated value for heating (MVh)/manipulated value for cooling (MVc), an offset (remaining deviation) generates. When an offset generates, the heating proportional band (Ph)/cooling proportional band (Pc) can be manually shifted by the amount of the offset (remaining deviation).

Ex. When using the manual reset function in the following conditions

- Control method: P control

CH□ Manual reset amount setting (Un\G724, Un\G740, Un\G756, Un\G772): 800 (80%)

The L60TC4 shifts the manipulated value for heating (MVh) by which the temperature is stabilized at the set value (SV) from 0% to 80%.

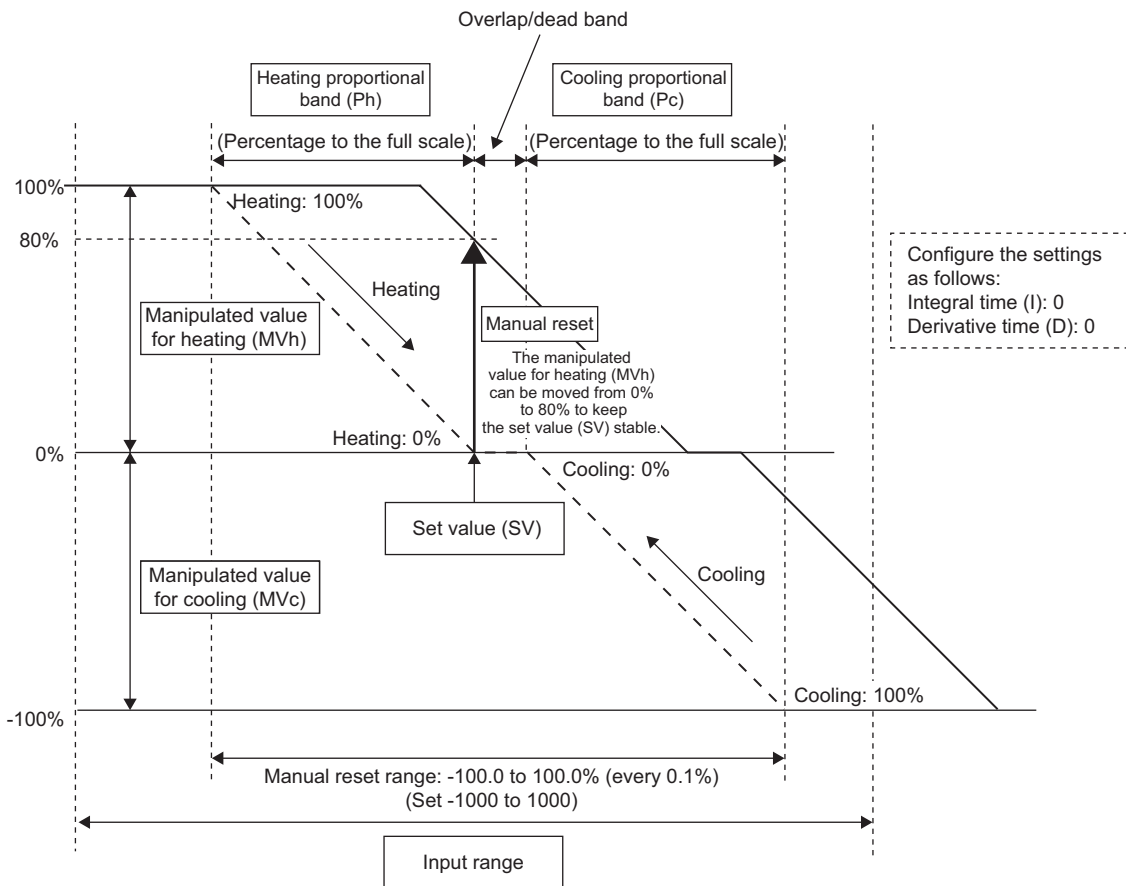

(3) Setting method

Set a value in the following buffer memory area.

- CH□ Manual reset amount setting (Un\G724, Un\G740, Un\G756, Un\G772) (Page 405, Appendix 2 (79))

8.2.5 Manual Control

Standard Heating-cooling

Manual control is a form of control for which the user sets the manipulated value (MV) manually instead of obtaining it automatically by PID control.

The manipulated value (MV) is checked every 250ms or 500ms^{*1}, and is reflected to transistor output.

*1 This depends on the setting in "Sampling Cycle Selection". (☞ Page 109, Section 7.2 (1) (b))

(1) Setting method

Follow the following procedure for setting.

- 1. Shift to the MAN (manual) mode. (Set MAN (1) in CH□ AUTO/MAN mode shift (Un\G50, Un\G82, Un\G114, Un\G146).) (☞ Page 367, Appendix 2 (26))**
- 2. Set the manipulated value (MV) in CH□ MAN output setting (Un\G51, Un\G83, Un\G115, Un\G147)^{*1} (☞ Page 368, Appendix 2 (27))**

*1 The setting range differs for standard control and heating-cooling control.
 Standard control: -50 to 1050 (-5.0% to 105.0%)
 Heating-cooling control: -1050 to 1050 (-105.0% to 105.0%)

8.2.6 Control output cycle unit selection function

Standard Heating-cooling

The unit of the control output cycle can be selected from 1s or 0.1s using this function.

When the control output cycle is set in 0.1s, control can be more attentive.

The control output cycle is the ON/OFF cycle of transistor output for the temperature control function.

The cycle can be set in the following buffer memory areas.

Control mode	Buffer memory area name	Buffer memory address				Reference
		CH1	CH2	CH3	CH4	
Standard control	CH□ Control output cycle setting	Un\G47	Un\G79	Un\G111	Un\G143	Page 364, Appendix 2 (23)
Heating-cooling control	CH□ Heating control output cycle setting	Un\G47	Un\G79	Un\G111	Un\G143	
	CH□ Cooling control output cycle setting	Un\G722	Un\G738	Un\G754	Un\G770	

(1) Setting method

Select 1s cycle or 0.1s cycle in "Control Output Cycle Unit Selection Setting".

Project window ⇨ [Intelligent Function Module] ⇨ Module name ⇨ [Switch Setting]

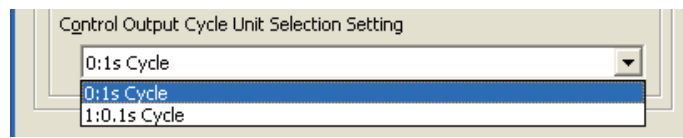

Point

- The setting range and default value of the control output cycle depends on this setting. (☞ Page 364, Appendix 2 (23))
- A setting value discrepancy error (error code: 002EH) occurs right after changing this setting. To recover from the error status, turn Set value backup instruction (Yn8) as follows: OFF→ON→OFF. Then, register the setting after the change to the L60TC4.

8.2.7 Auto tuning function

Standard Heating-cooling

The auto tuning function is designed for the L60TC4 to set the optimum PID constants automatically. In auto tuning, the PID constants are calculated according to the hunting cycle and amplitude generated by repeated overshoot and undershoot of the manipulated value (MV) toward the set value (SV).

(1) Auto tuning operation

The L60TC4 operates as follows.

Operation of the L60TC4	
1	Outputs for auto-tuning
2	Collects data from the point when the temperature process value (PV) reaches the set value (SV) after the first overshoot and undershoot
3	After data collection, auto tuning ends when PID constants and loop disconnection detection judgment time are set.

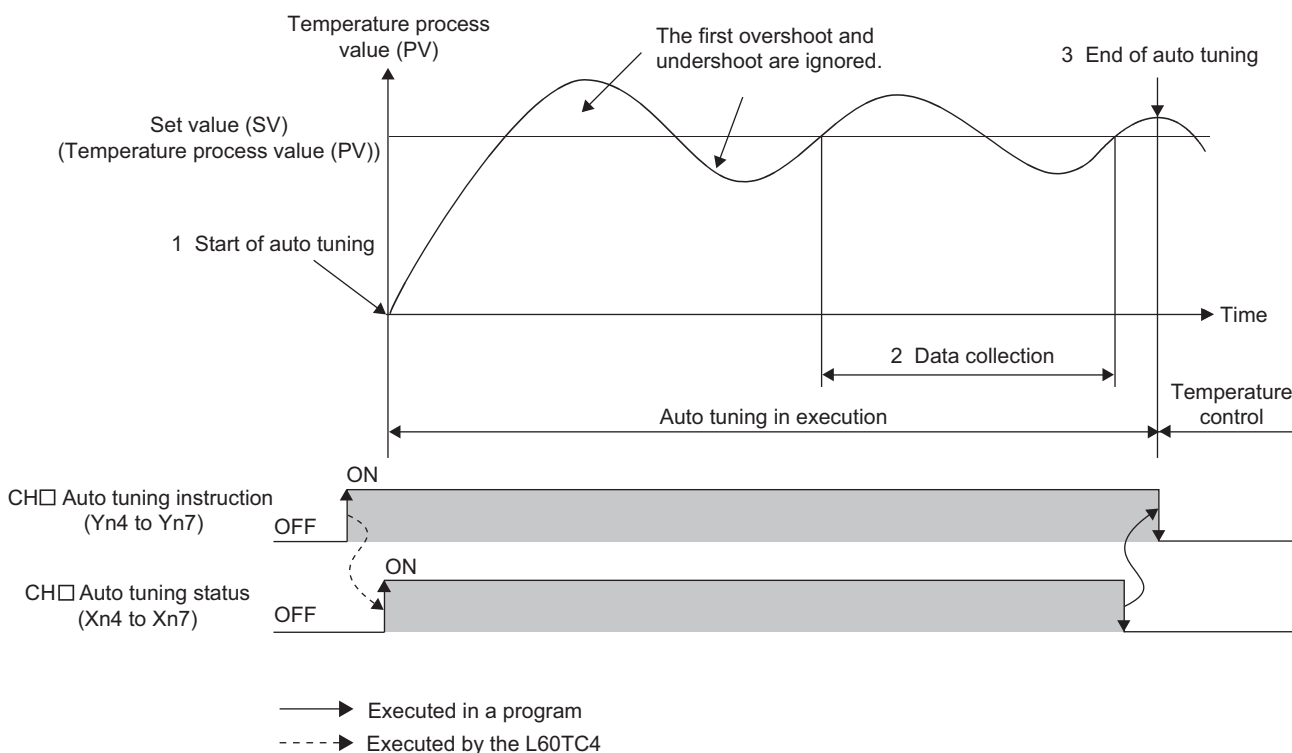

Remark

The time takes for auto tuning depends on the control subject.

8

8.2 Temperature Control Mode
8.2.7 Auto tuning function

(2) Buffer memory areas related to auto tuning

Auto tuning can be executed when the following data are set.

Note that other data must be preset to the values used for actual operation since actual control starts on completion of auto tuning.

When "0" is set to the proportional band (P)/heating proportional band (Ph), auto tuning is not executed.

(☞ Page 355, Appendix 2 (15))

Buffer memory area name	Buffer memory address				Reference
	CH1	CH2	CH3	CH4	
CH□ Input range	Un\G32	Un\G64	Un\G96	Un\G128	Page 345, Appendix 2 (12)
CH□ Set value (SV) setting	Un\G34	Un\G66	Un\G98	Un\G130	Page 354, Appendix 2 (14)
CH□ Upper limit output limiter	Un\G42	Un\G74	Un\G106	Un\G138	Page 360, Appendix 2 (19)
CH□ Lower limit output limiter	Un\G43	Un\G75	Un\G107	Un\G139	
CH□ Heating upper limit output limiter	Un\G42	Un\G74	Un\G106	Un\G138	
CH□ Cooling upper limit output limiter	Un\G721	Un\G737	Un\G753	Un\G769	
CH□ Output variation limiter setting	Un\G44	Un\G76	Un\G108	Un\G140	
CH□ Sensor correction value setting	Un\G45	Un\G77	Un\G109	Un\G141	Page 363, Appendix 2 (21)
CH□ Control output cycle setting	Un\G47	Un\G79	Un\G111	Un\G143	Page 364, Appendix 2 (23)
CH□ Heating control output cycle setting	Un\G47	Un\G79	Un\G111	Un\G143	
CH□ Cooling control output cycle setting	Un\G722	Un\G738	Un\G754	Un\G770	
CH□ Primary delay digital filter setting	Un\G48	Un\G80	Un\G112	Un\G144	Page 365, Appendix 2 (24)
CH□ AUTO/MAN mode shift	Un\G50	Un\G82	Un\G114	Un\G146	Page 367, Appendix 2 (26)
CH□ AT bias	Un\G53	Un\G85	Un\G117	Un\G149	Page 370, Appendix 2 (29)
CH□ Forward/reverse action setting	Un\G54	Un\G86	Un\G118	Un\G150	Page 371, Appendix 2 (30)
CH□ Auto tuning mode selection	Un\G184	Un\G185	Un\G186	Un\G187	Page 385, Appendix 2 (51)

(3) Storing the calculated value after auto tuning

After auto tuning is completed, the calculated values are stored into the following buffer memory areas.

Buffer memory area name	Buffer memory address				Reference
	CH1	CH2	CH3	CH4	
CH□ Proportional band (P) setting	Un\G35	Un\G67	Un\G99	Un\G131	Page 355, Appendix 2 (15)
CH□ Heating proportional band (Ph) setting	Un\G35	Un\G67	Un\G99	Un\G131	
CH□ Cooling proportional band (Pc) setting	Un\G720	Un\G736	Un\G752	Un\G768	
CH□ Integral time (I) setting	Un\G36	Un\G68	Un\G100	Un\G132	Page 357, Appendix 2 (16)
CH□ Derivative time (D) setting	Un\G37	Un\G69	Un\G101	Un\G133	Page 357, Appendix 2 (17)
CH□ Loop disconnection detection judgment time ^{*1}	Un\G59	Un\G91	Un\G123	Un\G155	Page 374, Appendix 2 (33)

*1 A value twice greater than the one in CH□ Integral time (I) setting (Un\G36, Un\G68, Un\G100, Un\G132) is automatically set. However, if this setting is 0(s) when auto tuning is in process, the loop disconnection detection judgment time is not stored.

(4) Backup of the calculated value on completion of auto tuning

By setting the following buffer memory area to Enable (1) at the start of auto tuning, the calculated value (☞ Page 142, Section 8.2.7 (3)) is automatically backed up into a non-volatile memory on completion of auto tuning.

- CH□ Automatic backup setting after auto tuning of PID constants (Un\G63, Un\G95, Un\G127, Un\G159) (☞ Page 378, Appendix 2 (37))

To read the calculated value (☞ Page 142, Section 8.2.7 (3)) from the non-volatile memory, set the following buffer memory area to Requested (1).

- CH□ Memory of PID constants read instruction (Un\G62, Un\G94, Un\G126, Un\G158) (☞ Page 377, Appendix 2 (36))

Point

To use the PID constants stored in the buffer memory also after the power is turned off, follow the methods below.

- Use the initial setting of GX Works2. (☞ Page 110, Section 7.3)
- Keep the PID constants in the non-volatile memory, and transfer them when the power is turned on from off or when the CPU module is released from the reset status. (☞ Page 235, Section 8.3.4)
- Write the value directly into the buffer memory through a program.

(5) Procedure of auto tuning

(a) GX Works2

Start from "Auto Tuning...".

 [Tool] ⇨ [Intelligent Function Module Tool] ⇨ [Temperature Control Module] ⇨ [Auto Tuning...]

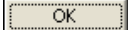
1. Select the module by which auto tuning is executed, and click  .

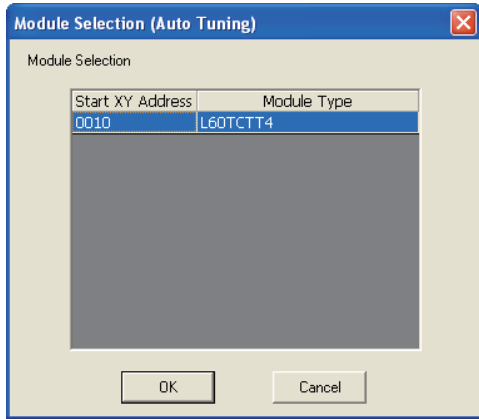

2. Click the "Auto Tuning Setting" tab.

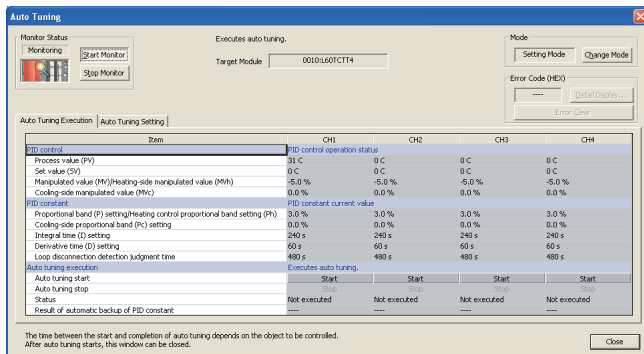

(To the next page)

(From the previous page)



3. Configure the auto tuning setting.

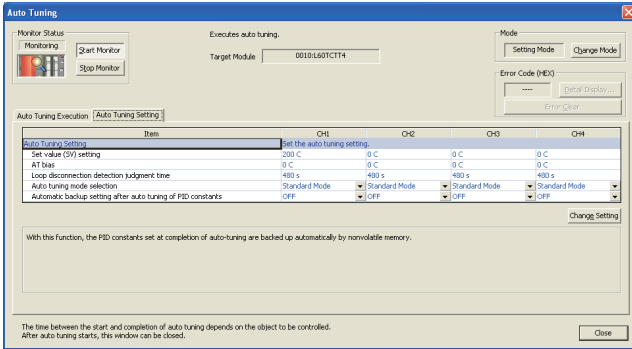

4. Click **Change Setting**.

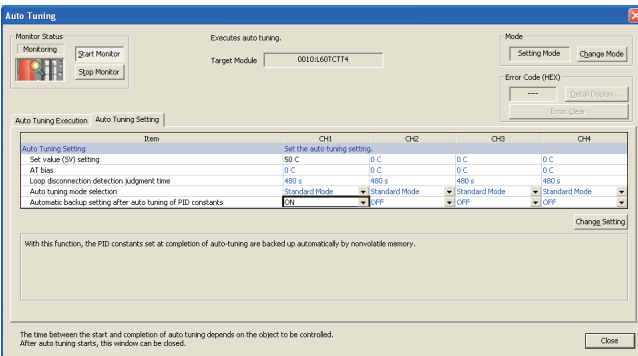

5. Click **Yes**.

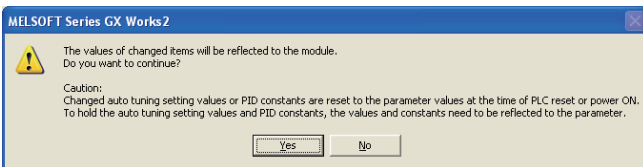

(To the next page)

(From the previous page)

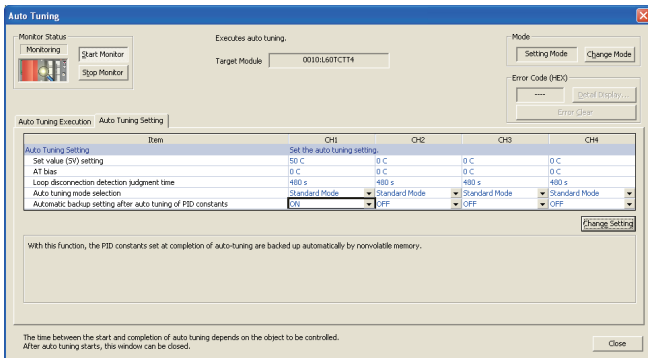

6. Click **Change Mode**.

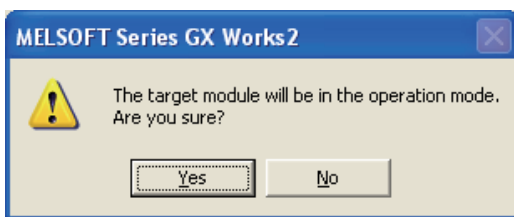

7. Click **Yes**.

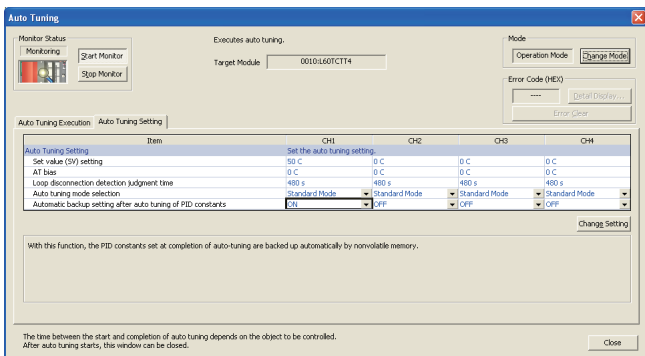

8. Click the "Auto Tuning Execution" tab.



(To the next page)

(From the previous page)

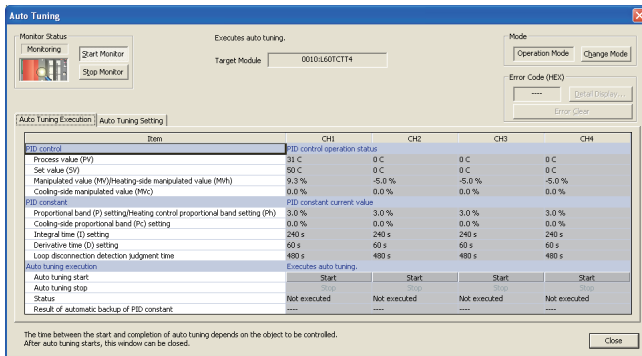

9. Click of the channel where auto tuning is to be executed.

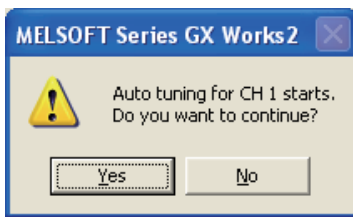

10. Click .

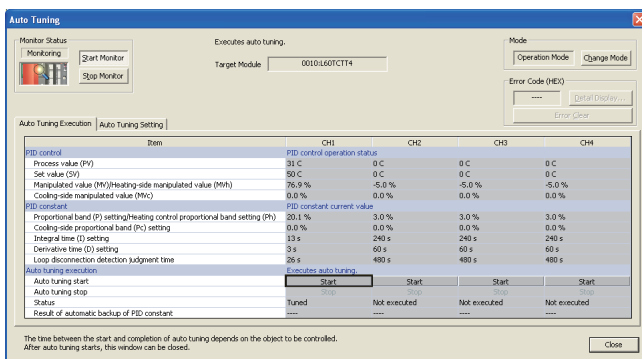

11. Check that "Status" has changed from "Executing" to "Tuned", and click .

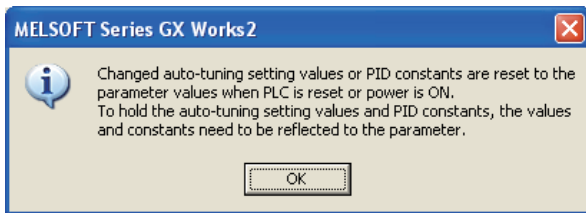

12. Click .

End

(b) Program

The execution procedure of auto tuning is as follows.

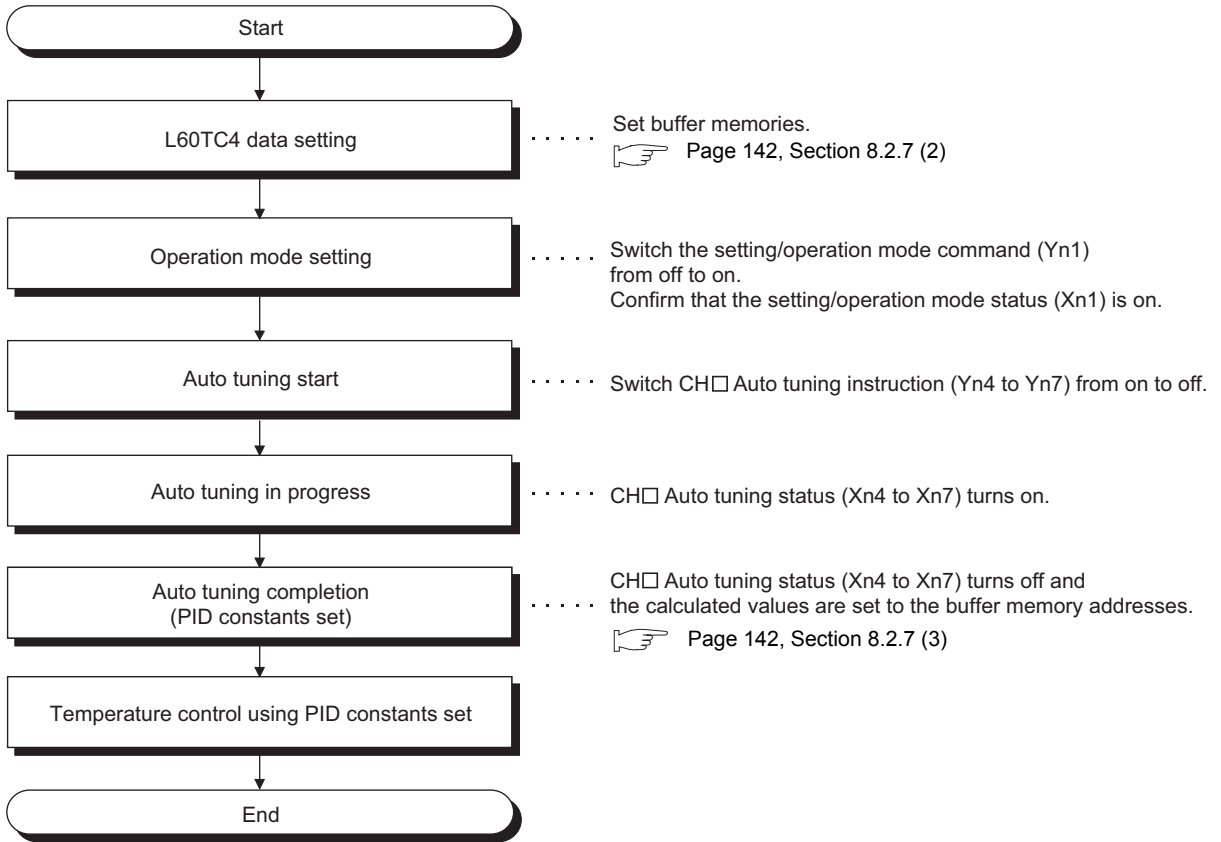

(6) Conditions where auto tuning cannot be executed

If one of the following conditions applies, auto tuning cannot be executed.

Conditions to start auto tuning		Reference
1	The module is in the setting mode (Setting/operation mode status (Xn1): OFF).	Page 324, Appendix 1.1 (2)
2	In standard control, CH□ Proportional band (P) setting (Un\G35, Un\G67, Un\G99, Un\G131) is set to 0. (operating in two-position control)	Page 355, Appendix 2 (15)
	In heating-cooling control, CH□ Heating proportional band (Ph) setting (Un\G35, Un\G67, Un\G99, Un\G131) is set to 0. (operating in two-position control)	
3	CH□ AUTO/MAN mode shift (Un\G50, Un\G82, Un\G114, Un\G146) is set to MAN (1).	Page 367, Appendix 2 (26)
4	Toward the corresponding channel, CH□ Unused channel setting (Un\G61, Un\G93, Un\G125, Un\G157) is set to Unused (1).	Page 376, Appendix 2 (35)
5	CH□ PID control forced stop instruction (YnC to YnF) is turned on.	Page 333, Appendix 1.2 (7)
6	Hardware failure has occurred. (The ERR. LED is on.)	Page 310, Section 11.3.2
7	CH□ Temperature process value (PV) (Un\G9 to Un\G12) has exceeded the temperature measurement range (CH□ Input range upper limit (b0 of Un\G5 to Un\G8) or CH□ Input range lower limit (b1 of Un\G5 to Un\G8) is 1 (ON)).	Page 336, Appendix 2 (3)
8	CH□ Memory of PID constants read instruction (Un\G62, Un\G94, Un\G126, Un\G158) is set to Requested (1).	Page 377, Appendix 2 (36)
9	CH□ Write completion flag (b4 to b7 of Un\G31) is on.	Page 343, Appendix 2 (11)

(a) When one of the conditions 1 to 5 applies

Auto tuning starts when the condition no longer applies.

(b) When the condition 7 applies

CH□ Auto tuning status (Xn4 to Xn7) turns on for a moment. Even though the temperature process value (PV) goes back within the temperature measurement range, auto tuning does not start until CH□ Auto tuning instruction (Yn4 to Yn7) is turned on from off once again.

(c) When the condition 8 or 9 applies

Even though the internal processing of auto tuning is completed and PID constants are stored, CH□ Auto tuning status (Xn4 to Xn7) does not turn off, therefore the auto tuning is not completed.

(7) Conditions where auto tuning ends in fail

The conditions are described below.

(a) Shift from the operation mode to the setting mode

Shifting from the operation mode to the setting mode (Setting/operation mode instruction (Yn1) is turned off from on) ends auto tuning in fail. Note that an exception is when PID continuation flag (Un\G169) is set to Continue (1). (Page 381, Appendix 2 (43))

(b) Setting change of the buffer memory during the execution of auto tuning

If a setting in the following buffer memory areas is changed during the execution of auto tuning, the processing ends in fail.

Buffer memory area name	Buffer memory address				Reference
	CH1	CH2	CH3	CH4	
CH□ Set value (SV) setting	Un\G34	Un\G66	Un\G98	Un\G130	Page 354, Appendix 2 (14)
CH□ Upper limit output limiter	Un\G42	Un\G74	Un\G106	Un\G138	Page 360, Appendix 2 (19)
CH□ Lower limit output limiter	Un\G43	Un\G75	Un\G107	Un\G139	
CH□ Cooling upper limit output limiter	Un\G721	Un\G737	Un\G753	Un\G769	
CH□ Sensor correction value setting	Un\G45	Un\G77	Un\G109	Un\G141	Page 363, Appendix 2 (21)
CH□ Control output cycle setting	Un\G47	Un\G79	Un\G111	Un\G143	Page 364, Appendix 2 (23)
CH□ Cooling control output cycle setting	Un\G722	Un\G738	Un\G754	Un\G770	
CH□ Primary delay digital filter setting	Un\G48	Un\G80	Un\G112	Un\G144	Page 365, Appendix 2 (24)
CH□ AUTO/MAN mode shift	Un\G50	Un\G82	Un\G114	Un\G146	Page 367, Appendix 2 (26)
CH□ AT bias	Un\G53	Un\G85	Un\G117	Un\G149	Page 370, Appendix 2 (29)
CH□ Forward/reverse action setting	Un\G54	Un\G86	Un\G118	Un\G150	Page 371, Appendix 2 (30)
CH□ Unused channel setting	Un\G61	Un\G93	Un\G125	Un\G157	Page 376, Appendix 2 (35)
Cold junction temperature compensation selection	Un\G182				Page 384, Appendix 2 (49)

(c) Out of the temperature measurement range

If CH□ Temperature process value (PV) (Un\G9 to Un\G12) exceeds the temperature measurement range (CH□ Input range upper limit (b0 of Un\G5 to Un\G8) or CH□ Input range lower limit (b1 of Un\G5 to Un\G8) becomes 1 (ON)), auto tuning ends in fail. (Page 336, Appendix 2 (3))

(d) Time until the temperature process value (PV) reaches the set value (SV) for the first time or a half the hunting cycle of the temperature process value (PV)

If the time below exceeds two hours, auto tuning ends in fail.

- Time from the start of auto tuning until CH□ Temperature process value (PV) (Un\G9 to Un\G12) reaches the set value (SV) for the first time
- A half the hunting cycle of CH□ Temperature process value (PV) (Un\G9 to Un\G12)

Point

For the time above not to exceed two hours, bring the temperature of the subject close to the set value (SV) in advance, then execute auto tuning.

(e) Calculated values of PID constants after auto tuning

If a calculated value of PID constants after auto tuning exceeds one of the following ranges, auto tuning ends in fail.

- CH□ Proportional band (P) setting (Un\G35, Un\G67, Un\G99, Un\G131): 1 to 10000 (0.1% to 1000.0%)
- CH□ Integral time (I) setting (Un\G36, Un\G68, Un\G100, Un\G132): 1 to 3600 (1s to 3600s)
- CH□ Derivative time (D) setting (Un\G37, Un\G69, Un\G101, Un\G133): 0 to 3600 (0s to 3600s)

Point

If auto tuning ends in fail due to the calculated value of PID constants as described above, the system configuration needs to be reconsidered (such as selecting proper heater capacity).

(f) Change of the upper limit setting limiter or lower limit setting limiter and the set value (SV)

If the set value (SV) goes out of the setting range due to the change in one of the following buffer memory areas, auto tuning ends in fail.

- CH□ Upper limit setting limiter (Un\G55, Un\G87, Un\G119, Un\G151)
- CH□ Lower limit setting limiter (Un\G56, Un\G88, Un\G120, Un\G152)

(g) Other conditions

In addition to the conditions described up until here, if any of the following conditions applies, auto tuning ends in fail.

- CH□ PID control forced stop instruction (YnC to YnF) has been turned on from off. (☞ Page 333, Appendix 1.2 (7))
- Hardware failure has occurred.
- In standard control, CH□ Proportional band (P) setting (Un\G35, Un\G67, Un\G99, Un\G131) has been set to 0. (has been set to two-position control) (☞ Page 355, Appendix 2 (15))
- In heating-cooling control, CH□ Heating proportional band (Ph) setting (Un\G35, Un\G67, Un\G99, Un\G131) has been set to 0. (has been set to two-position control) (☞ Page 355, Appendix 2 (15))

(8) Operation on completion of auto tuning**(a) Normal completion**

The L60TC4 operates as follows.

- Turns off CH□ Auto tuning status (Xn4 to Xn7)
- Stores the PID constants in the buffer memory (☞ Page 142, Section 8.2.7 (3))
- Stores a value in CH□ Loop disconnection detection judgment time (Un\G59, Un\G91, Un\G123, Un\G155) (If this was set to 0 (s) at the start of auto tuning, the setting remains unchanged.)

(b) Abnormal completion

The L60TC4 operates as follows.

- Turns off CH□ Auto tuning status (Xn4 to Xn7).
- Does not store the PID constants in the buffer memory. (☞ Page 142, Section 8.2.7 (3))

(9) Checking the completion of auto tuning

The completion of auto tuning can be checked by the status change from on to off in CH□ Auto tuning status (Xn4 to Xn7).

(10)Adjustment after auto tuning

To change the control response toward the PID constants calculated by auto tuning, change the setting in the following buffer memory area.

- CH□ Control response parameter (Un\G49, Un\G81, Un\G113, Un\G145) ( Page 366, Appendix 2 (25))

8.2.8 Simple Two-degree-of-freedom

Standard Heating-cooling

This is the simplified control form of the two-degree-of-freedom PID control. In this form of PID control, the L60TC4 controls the target subject using not only PID constants but also the control response parameter. The response speed toward the change of the set value (SV) can be selected from three levels.

General PID control is called one-degree-of freedom PID control. In the one-degree-of freedom PID control, when PID constants to improve "response to the change of the set value (SV)" are set, "response to the disturbance" degrades. Conversely, when PID constants to improve "response to the disturbance" are set, "response to the change of the set value (SV)" degrades.

On the other hand, in the two-degree-of-freedom PID control, "response to the change of the set value (SV)" and "response to the disturbance" can be compatible with each other.

Note that required parameter settings increase and PID constants can hardly be auto-set by the auto tuning function for complete two-degree-of-freedom PID control. Therefore, the L60TC4 operates in the simple two-degree-of-freedom PID control for which parameters are simplified.

The level of "response to the change of the set value (SV)" can be selected from the following, maintaining the PID constants that improve "response to the disturbance".

- Fast
- Normal
- Slow

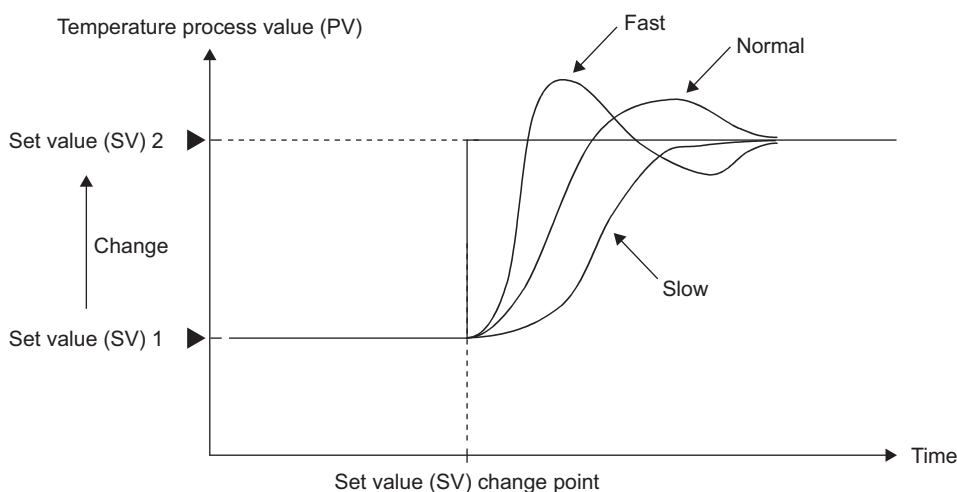

(1) Setting method

Set a value on "Control response parameter".

Project window ⇨ [Intelligent Function Module] ⇨ Module name ⇨ [Parameter]

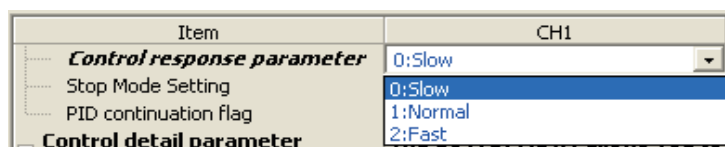

8.2.9 Derivative Action Selection Function

Standard Heating-cooling

An derivative action appropriate for each of fixed value action and ramp action can be selected and the action characteristic can be improved using this function.

(1) Action

Each type of derivative action operates as shown below.

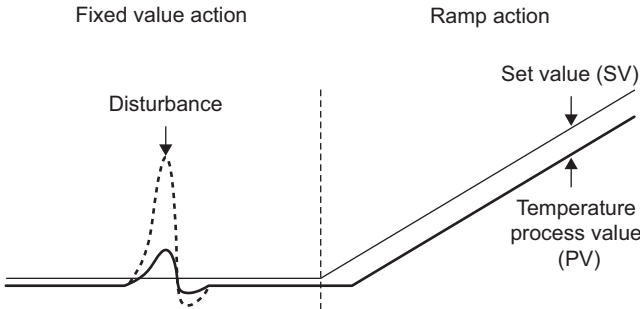
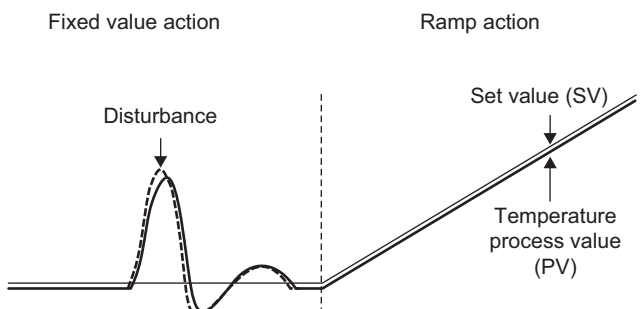
CH□ Derivative action selection (Un\G729, Un\G745, Un\G761, Un\G777)	Action	
Measured value derivation (0)	 <p>The graph shows two phases: 'Fixed value action' and 'Ramp action'. In the fixed value phase, a 'Disturbance' (dashed line) causes a spike in the 'Temperature process value (PV)' (solid line), but it quickly returns to the 'Set value (SV)' (horizontal line). In the ramp action phase, the 'Temperature process value (PV)' (solid line) follows the 'Set value (SV)' (diagonal line) smoothly.</p>	<p>This setting effectively prevents the temperature from being affected by disturbance, though the performance to follow the set value can be low.</p>
Deviation derivation (1)	 <p>The graph shows two phases: 'Fixed value action' and 'Ramp action'. In the fixed value phase, a 'Disturbance' (dashed line) causes the 'Temperature process value (PV)' (solid line) to overshoot the 'Set value (SV)' (horizontal line) before settling back to it. In the ramp action phase, the 'Temperature process value (PV)' (solid line) follows the 'Set value (SV)' (diagonal line) smoothly.</p>	<p>This setting allows the temperature to follow the set value well, though the disturbance effect is great.</p>

(2) Setting method

Set a value on "Derivative action selection".

Project window ⇨ [Intelligent Function Module] ⇨ Module name ⇨ [Parameter]

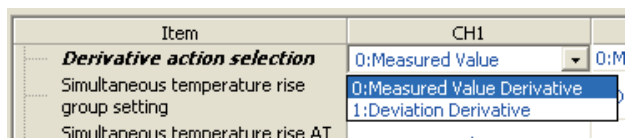

8.2.10 setting Change Rate Limiter Setting Function

Standard Heating-cooling

When the set value (SV) is changed, the change rate in the specified time unit can be set on "Setting Change Rate Limiter Setting". The user can select whether to set this rate for temperature rise and temperature drop individually or at once.

(1) Setting method

(a) Batch/individual setting for temperature rise and temperature drop

Select the value on "Setting Change Rate Limiter Setting".

Project window ⇨ [Intelligent Function Module] ⇨ Module name ⇨ [Switch Setting]

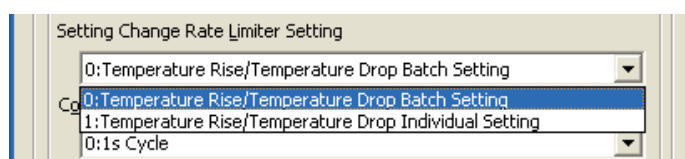

(b) Change rate setting

For batch-change, set "Setting change rate limiter or Setting change limiter (Temperature rise)" only.

Project window ⇨ [Intelligent Function Module] ⇨ Module name ⇨ [Parameter]

Item	CH1
Setting change rate limiter or Setting change rate limiter (Temperature rise)	40.0 %
Setting change rate limiter	

For individual setting, set "Setting change rate limiter or Setting change limiter (Temperature rise)" and "Setting change rate limiter (Temperature drop)".

Project window ⇨ [Intelligent Function Module] ⇨ Module name ⇨ [Parameter]

Item	CH1
Setting change rate limiter or Setting change rate limiter (Temperature rise)	40.0 %
Setting change rate limiter (Temperature drop)	20.0 %

(c) Time unit setting

Set the time unit of the setting change rate limiter on "Setting change rate limiter Unit time setting".

🖱️ Project window ⇨ [Intelligent Function Module] ⇨ Module name ⇨ [Parameter]

Item	CH1
Setting change rate limiter Unit time setting	5 s
Back current suppression control	

Ex. Operation of when individual setting is selected on Switch Setting

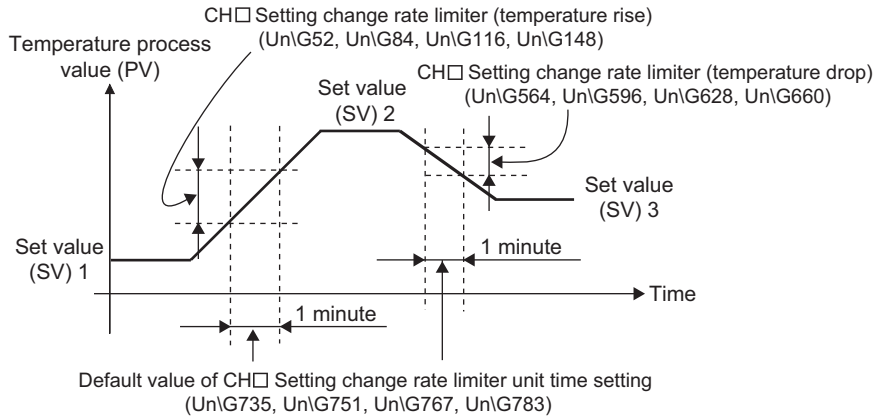

8.2.11 Alert Function

Standard Heating-cooling

When the process value (PV) or deviation reaches the value set in advance, the system is set in an alert status. Use this function to activate danger signals of devices or safety devices.

The alert function is classified into input alerts and deviation alerts depending on the setting of the alert mode.

- Input alert: upper limit input alert, lower limit input alert (☞ Page 157, Section 8.2.11 (1))
- Deviation alert: upper limit deviation alert, lower limit deviation alert, upper lower limit deviation alert, within-range alert (☞ Page 158, Section 8.2.11 (2))

(1) Input alert

With the upper limit input alert, when the process value (PV) is equal to or greater than the alert set value, the system is put in an alert status.

With the lower limit input alert, when the process value (PV) is equal to or less than the alert set value, the system is put in an alert status.

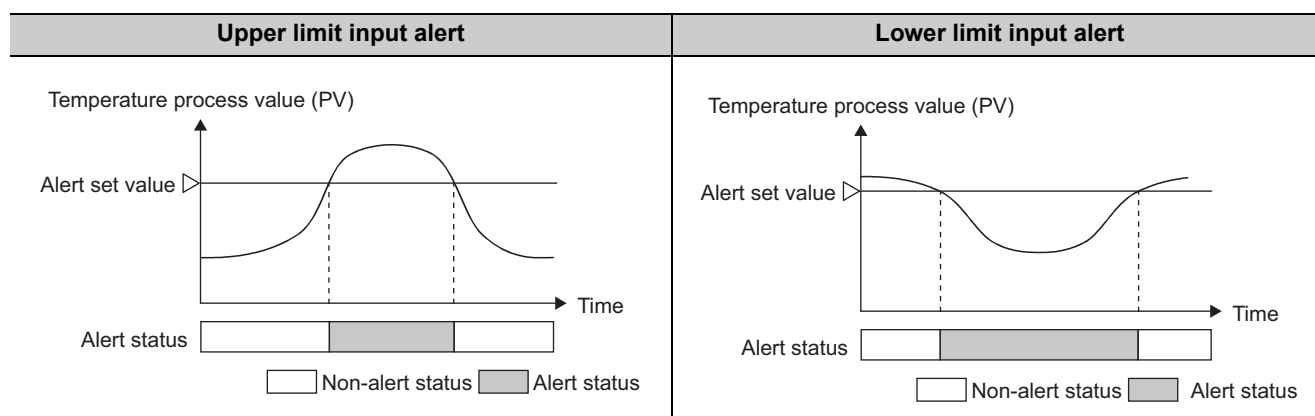

(a) Setting method

Set the alert mode. (☞ Page 167, Section 8.2.11 (7) (a))

- Upper limit input alert: Set the alert mode to "1: Upper Limit Input Alert".
- Lower limit input alert: Set the alert mode to "2: Lower Limit Input Alert".

(2) Deviation alert

With the deviation alert, when the deviation (E) between the temperature process value (PV) and the set value (SV) meets a particular condition, the system is put in an alert status.

The set value (SV) to be referred is either "set value (SV) monitor" or "set value (SV) setting" depending on the alert mode. When a setting change rate limiter is specified, "set value (SV) monitor" follows the set value (SV) by the specified change rate. (For details on the setting change rate limiter setting, refer to  Page 369, Appendix 2 (28).)

The following table describes the use of each set value (SV) of when a setting change rate limiter is specified, and can be referred to use a deviation alert.

Reference area of the set value (SV)	Use (when the set value (SV) is changed)
CH□ Set value (SV) monitor (Un\G25 to Un\G28)	This value is used when the temperature process value (PV) needs to follow the changing set value (SV) within a consistent deviation (E). If the temperature process value (PV) does not follow the set value (SV) and strays out of the set deviation range, an alert occurs.
CH□ Set value (SV) setting (Un\G34, Un\G66, Un\G98, Un\G130)	This value is used for the alert occurrence to be determined only by the deviation (E) from the set value (SV). In this case, how well the temperature process value (PV) is following the changing set value (SV) does not matter. Even if the value in CH□ Set value (SV) monitor (Un\G25 to Un\G28) is changing, an alert can occur depending on the deviation (E) from the set value (SV).

(a) Set value (SV) and the setting change rate limiter setting

The following figures show the relationships of two types of set value (SV) depending on whether the setting change rate limiter is specified or not.

- When the setting change rate limiter is not specified: The two types of set value (SV) are the same value.

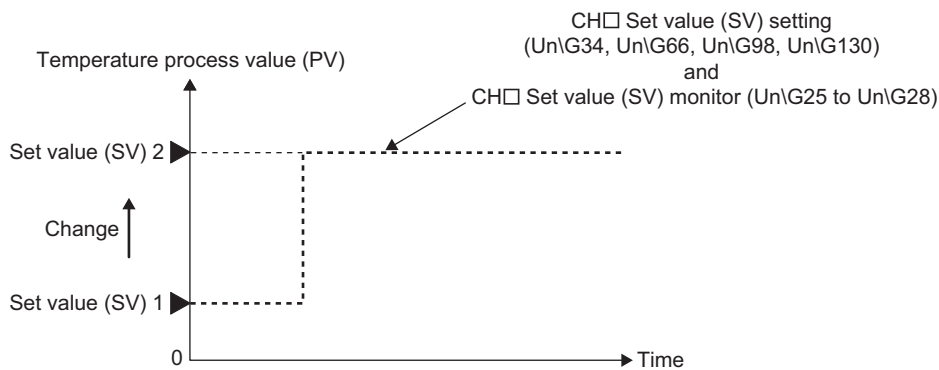

- When the setting change rate limiter is specified: The value in CH□ Set value (SV) monitor (Un\G25 to Un\G28) follows the set value (SV) of after the setting is reflected.

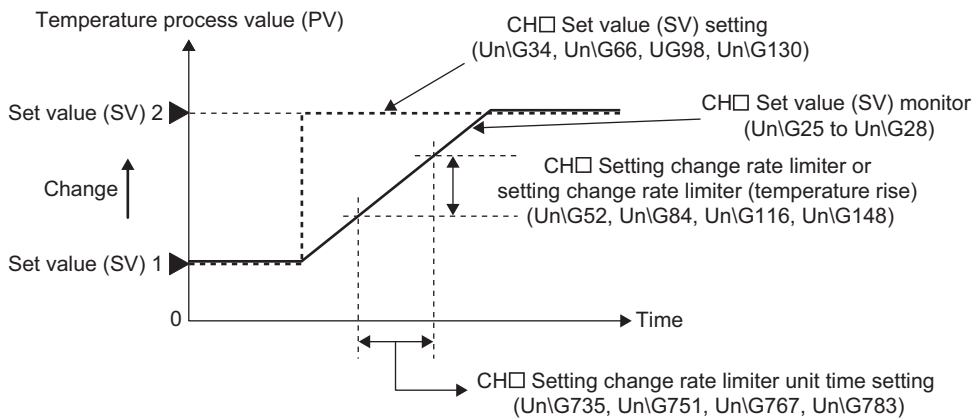

(b) Upper limit deviation alert

When the deviation (E) is equal to or greater than the alert set value, the system is put in an alert status.

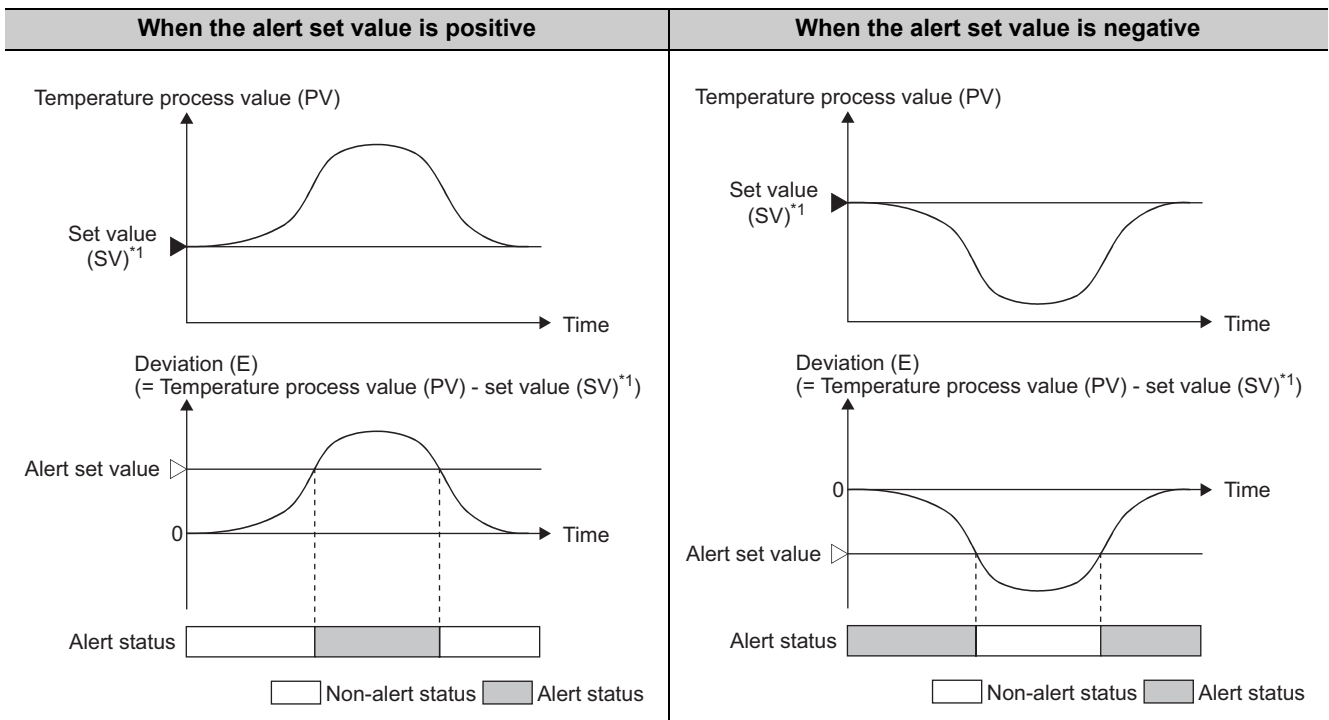

*1 Depending on the alert mode, this value becomes "set value (SV) monitor" or "set value (SV) setting". (☞ Page 158, Section 8.2.11 (2) (a))

(c) Lower limit deviation alert

When the deviation (E) is equal to or less than the alert set value, the system is put in an alert status.

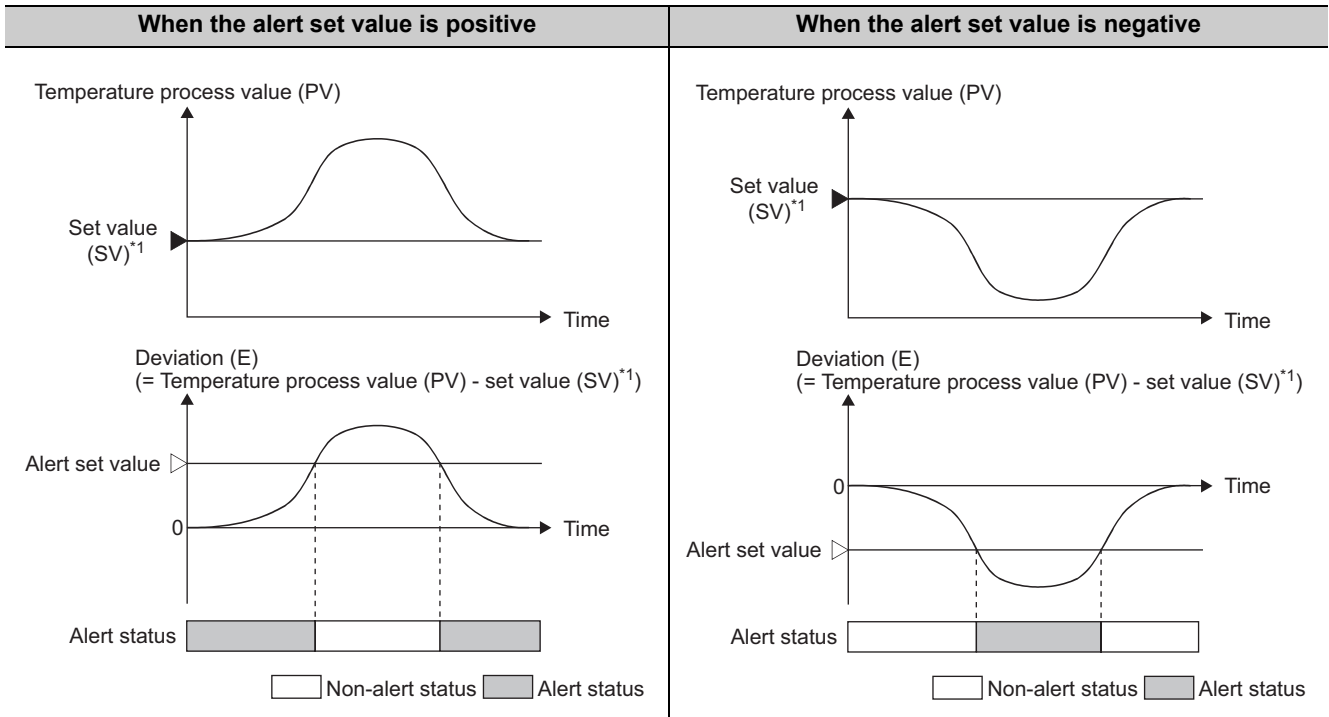

*1 Depending on the alert mode, this value becomes "set value (SV) monitor" or "set value (SV) setting". (☞ Page 158, Section 8.2.11 (2) (a))

(d) Upper lower limit deviation alert

When one of the following conditions is satisfied, the system is put in an alert status.

- Deviation (E) \geq Alert set value
- Deviation (E) \leq -(Alert set value)

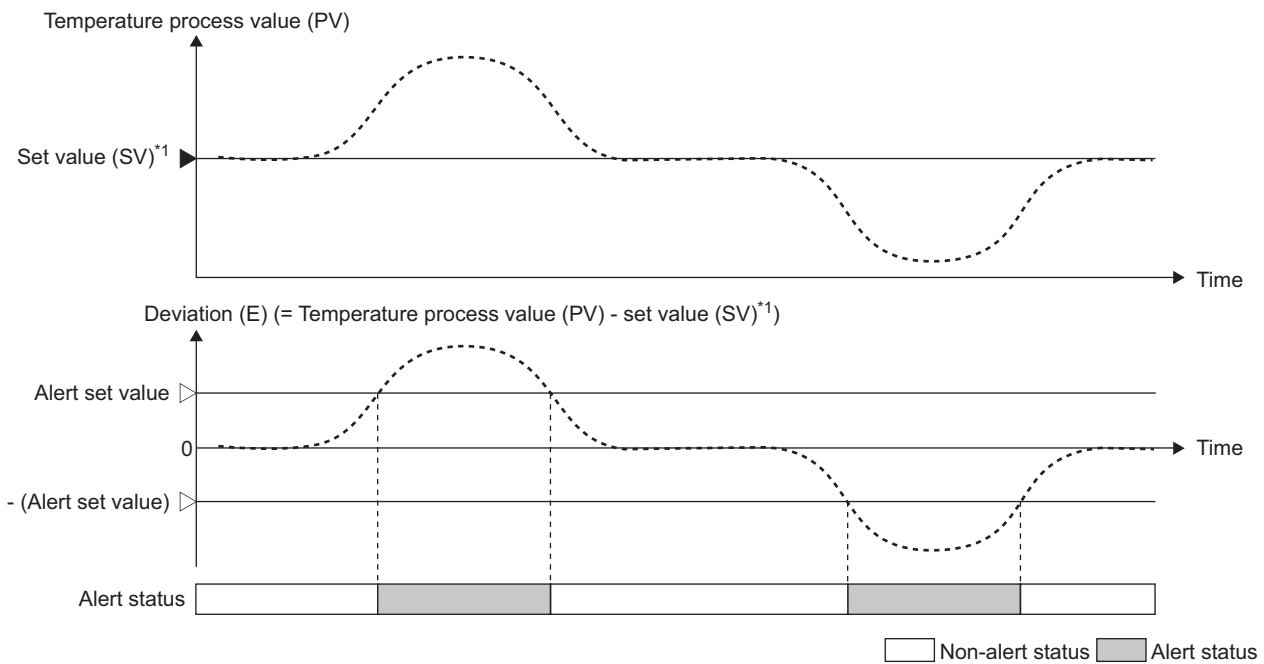

*1 Depending on the alert mode, this value becomes "set value (SV) monitor" or "set value (SV) setting". (☞ Page 158, Section 8.2.11 (2) (a))

(e) Within-range alert

When the following condition is satisfied, the system is put in an alert status.

- $-(\text{Alert set value}) \leq \text{Deviation (E)} \leq \text{Alert set value}$

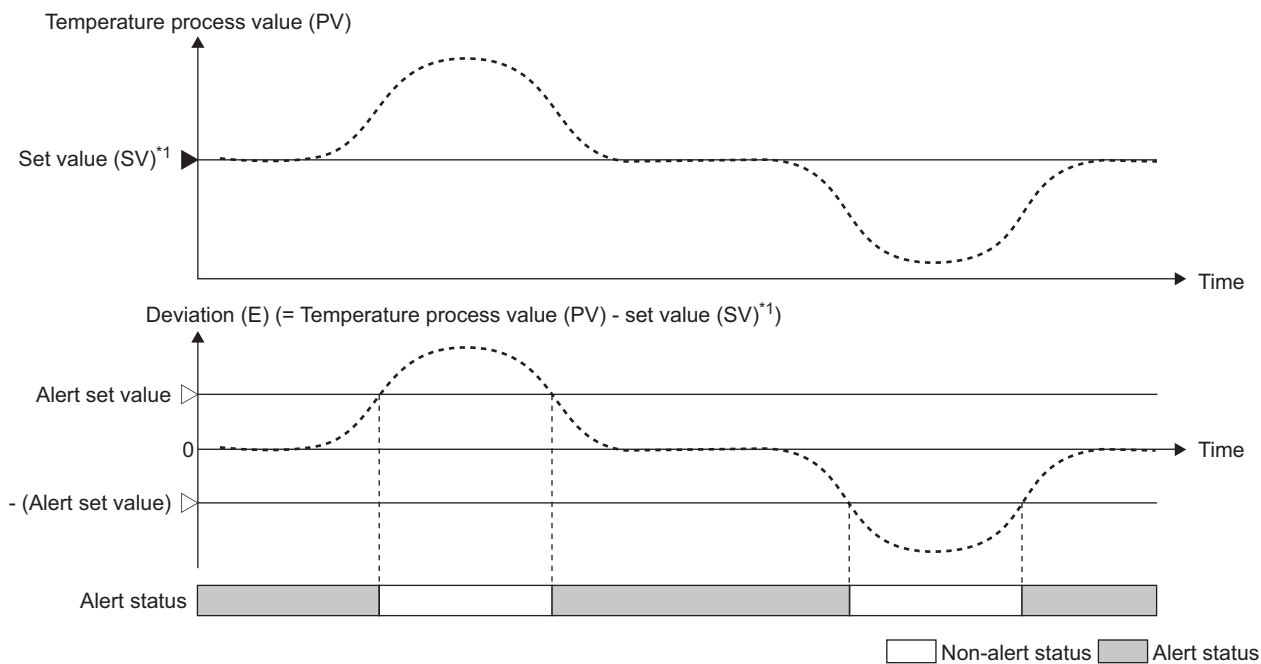

*1 Depending on the alert mode, this value becomes "set value (SV) monitor" or "set value (SV) setting". (☞ Page 158, Section 8.2.11 (2) (a))

(f) Setting method (alert mode and the set value (SV) to be referred)

Select one of the two types of set value (SV) described in  Page 158, Section 8.2.11 (2) by specifying an alert mode.

- When the alert judgment requires the value in CH□ Set value (SV) monitor (Un\G25 to Un\G28), set one of the following values.

Alert mode setting ( Page 167, Section 8.2.11 (7) (a))	
Setting value	Alert mode name
3	Upper Limit Deviation Alert
4	Lower Limit Deviation Alert
5	Upper/Lower Deviation Alert
6	Within-Range Alert
9	Upper Limit Deviation Alert with Wait
10	Lower Limit Deviation Alert with Wait
11	Upper/Lower Limit Deviation Alert with Wait
12	Upper Limit Deviation Alert with Re-Wait
13	Lower Limit Deviation Alert with Re-Wait
14	Upper/Lower Limit Deviation Alert with Re-Wait

- When the alert judgment requires the value in CH□ Set value (SV) setting (Un\G34, Un\G66, Un\G98, Un\G130), set one of the following values.

Alert mode setting ( Page 167, Section 8.2.11 (7) (a))	
Setting value	Alert mode name
15	Upper Limit Deviation Alert (Use Set Value (SV) Setting Value)
16	Lower Limit Deviation Alert (Use Set Value (SV) Setting Value)
17	Upper lower deviation alert (Use Set Value (SV) Setting Value)
18	Within-range deviation alert (Use Set Value (SV) Setting Value)
19	Upper Limit Deviation Alert with Wait (Use Set Value (SV) Setting Value)
20	Lower Limit Deviation Alert with Wait (Use Set Value (SV) Setting Value)
21	Upper/Lower Limit Deviation Alert with Wait (Use Set Value (SV) Setting Value)
22	Upper Limit Deviation Alert with Re-Wait (Use Set Value (SV) Setting Value)
23	Lower Limit Deviation Alert with Re-Wait (Use Set Value (SV) Setting Value)
24	Upper/Lower Limit Deviation Alert with Re-Wait (Use Set Value (SV) Setting Value)

(3) Alert with standby

Even if the temperature process value (PV) or deviation (E) is in a condition to be in an alert status when the module's status is changed from the setting mode to the operation mode (Setting/operation mode instruction (Yn1): OFF→ON), the alert does not occur. The alert function can be disabled until the temperature process value (PV) or deviation (E) strays out of the condition to be in an alert status.

Ex. When the alert mode is set to Lower limit deviation alert with standby (10)
The alert function is inactive until the deviation (E) exceeds the alert set value (right figure below).

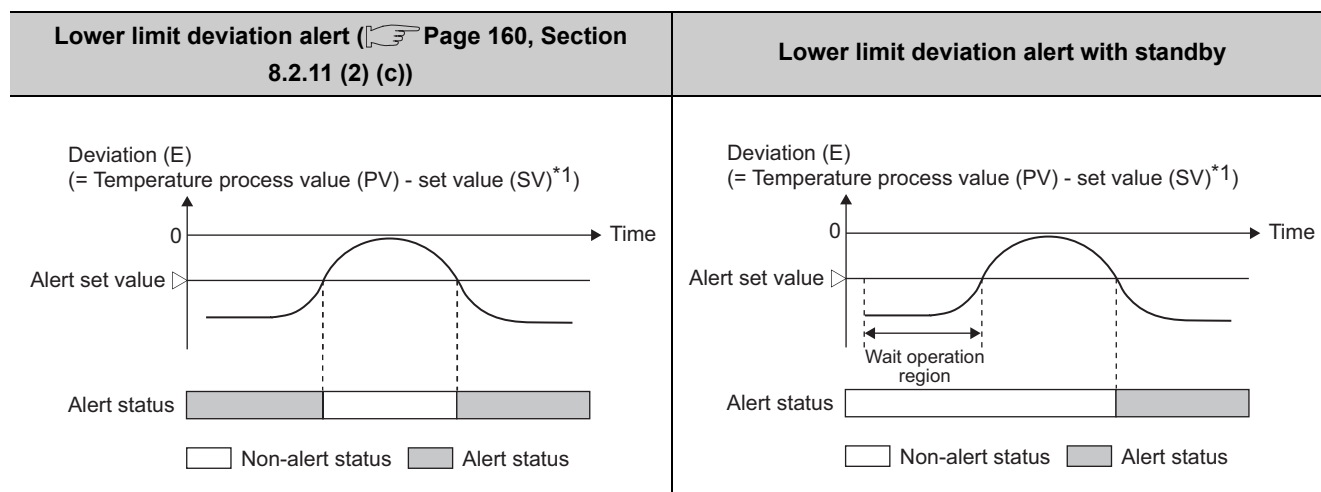

*1 Depending on the alert mode, this value becomes "set value (SV) monitor" or "set value (SV) setting". (☞ Page 158, Section 8.2.11 (2) (a))

Point

When the system goes into the non-alert status even once after an alert judgment started following the setting of the alert mode, the alert with standby will be inactive even if the mode is changed to the one with standby.

(a) Setting method

Select one of the following alert modes.

Alert mode setting (☞ Page 167, Section 8.2.11 (7) (a))	
Setting value	Alert mode name
7	Upper Limit Input Alert with Wait
8	Lower Limit Input Alert with Wait
9	Upper Limit Deviation Alert with Wait
10	Lower Limit Deviation Alert with Wait
11	Upper/Lower Limit Deviation Alert with Wait
19	Upper Limit Deviation Alert with Wait (Use Set Value (SV) Setting Value)
20	Lower Limit Deviation Alert with Wait (Use Set Value (SV) Setting Value)
21	Upper/Lower Limit Deviation Alert with Wait (Use Set Value (SV) Setting Value)

(4) Alert with standby (second time)

A function to deactivate the alert function once again when the set value (SV) is changed is added to an alert with standby. This is called an alert with standby (second time).

When control needs the set value (SV) change, the alert supposed to occur can be avoided when the set value is changed by selecting an alert with standby (second time).

Ex. When the temperature process value (PV) is on the position as below before the set value (SV) change

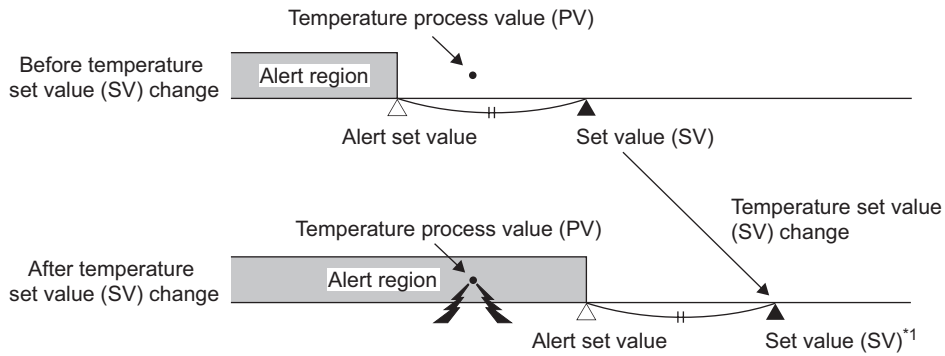

*1 Depending on the alert mode, this value becomes "set value (SV) monitor" or "set value (SV) setting". (Page 158, Section 8.2.11 (2) (a))

For a deviation alert, when the set value (SV) is changed, the temperature process value (PV) goes into the alert area; therefore, the system goes into an alert status.

To prevent the case above, the alert output is put on standby.

(a) Setting method

Select one of the following alert modes.

Alert mode setting (Page 167, Section 8.2.11 (7) (a))	
Setting value	Alert mode name
12	Upper Limit Deviation Alert with Re-Wait
13	Lower Limit Deviation Alert with Re-Wait
14	Upper/Lower Limit Deviation Alert with Re-Wait
22	Upper Limit Deviation Alert with Re-Wait (Use Set Value (SV) Setting Value)
23	Lower Limit Deviation Alert with Re-Wait (Use Set Value (SV) Setting Value)
24	Upper/Lower Limit Deviation Alert with Re-Wait (Use Set Value (SV) Setting Value)

Remark

If a setting change rate limiter is specified, an alert with standby (second time) is not active even though one of the following alert modes is selected.

Alert mode setting (☞ Page 167, Section 8.2.11 (7) (a))	
Setting value	Alert mode name
12	Upper Limit Deviation Alert with Re-Wait
13	Lower Limit Deviation Alert with Re-Wait
14	Upper/Lower Limit Deviation Alert with Re-Wait

The standby (second time) is used to prevent alert occurrence when the set value (SV) is changed.
 If a setting change rate limiter is specified, the value in CH□ Set value (SV) monitor (Un\G25 to Un\G28) gradually changes following the set value (SV) when the set value (SV) is changed. Suppose that the standby (second time) function is activated under such occasion. The alert standby would be always active; therefore an alert would not be output even when the temperature process value (PV) is not following the value in CH□ Set value (SV) monitor (Un\G25 to Un\G28). To prevent such cases, the standby (second time) function is deactivated if a setting change rate limiter is used.

(5) Condition for alert judgment

Whether alert occurrence is judged or not depends on the settings of the followings:

- Setting/operation mode instruction (Yn1) (Page 330, Appendix 1.2 (1))
- PID continuation flag (Un\G169) (Page 381, Appendix 2 (43))
- CH□ PID control forced stop instruction (YnC to YnF) (Page 333, Appendix 1.2 (7))
- CH□ Stop mode setting (Un\G33, Un\G65, Un\G97, Un\G129) (Page 353, Appendix 2 (13))

The following table shows the relationship between each setting above and the execution of alert judgment.

○: Judged ×: Not judged

Setting/operation mode instruction (Yn1) ^{*1}	PID continuation flag (Un\G169)	CH□ PID control forced stop instruction (YnC to YnF)	CH□ Stop mode setting (Un\G33, Un\G65, Un\G97, Un\G129)	Alert judgment	
Power ON, Setting mode	Stop (0)/Continue (1)	OFF/ON	Stop (0)	×	
			Monitor (1)	×	
			Alert (2)	○	
Operation mode (operating)	Stop (0)/Continue (1)	OFF	Stop (0)/Monitor (1)/Alert (2)	○	
		ON	Stop (0)	×	
			Monitor (1)	×	
Setting mode (after operation)	Stop (0)	OFF/ON	Alert (2)	○	
			Stop (0)	×	
			Monitor (1)	×	
	Continue (1)	OFF	ON	Alert (2)	○
				Stop (0)/Monitor (1)/Alert (2)	○
				Stop (0)	×
			Monitor (1)	×	
			Alert (2)	○	

*1 For details, refer to Page 324, Appendix 1.1 (2).

Even if the conditions above are satisfied, when CH□ Unused channel setting (Un\G61, Un\G93, Un\G125, Un\G157) is set to Unused (1), alert judgment is not executed. (Page 376, Appendix 2 (35))

(6) Condition where CH□ Alert occurrence flag (XnC to XnF) turns off

The condition where CH□ Alert occurrence flag turns off differs depending on the setting of the following buffer memory area.

- CH□ Stop mode setting (Un\G33, Un\G65, Un\G97, Un\G129) (Page 353, Appendix 2 (13))

CH□ Stop mode setting (Un\G33, Un\G65, Un\G97, Un\G129)	Condition where CH□ Alert occurrence flag (XnC to XnF) turns off
Stop (0)	When the cause of the alert is resolved, or when the system is shifted from the operation mode to the setting mode (when Setting/operation mode instruction (Yn1) is turned off from on).
Monitor (1)	
Alert (2)	When the cause of the alert is resolved,

(7) Setting alert modes and alert set values

Settings of the alert mode and alert set value are described below.

(a) Alert mode

Set the alert mode. Up to four modes can be set for each channel. Set modes in "Alert 1 mode setting" to "Alert 4 mode setting".

Project window ⇨ [Intelligent Function Module] ⇨ Module name ⇨ [Parameter]

Item	CH1	CH2
Alert function setting	Set the temperature process value (PV) or warning status of deflection.	
Alert 1 mode setting	1:Upper Limit Input Alert	0:Not Warning
Alert 2 mode setting	0:Not Warning	0:Not Warning
Alert 3 mode setting	2:Lower Limit Input Alert	0:Not Warning
Alert 4 mode setting	0:Not Warning	0:Not Warning
Alert set value 1	7:Upper Limit Input Alert with Wait	
Alert set value 2	8:Lower Limit Input Alert with Wait	
Alert set value 3	9:Upper Limit Deviation Alert with Wait	
Alert set value 4	10:Lower Limit Deviation Alert with Wait	
Alert dead band setting	11:Upper/Lower Limit Deviation Alert with Wait	
Number of alert delay	12:Upper Limit Deviation Alert with Re-Wait	
Loop disconnection detection judgment time	13:Lower Limit Deviation Alert with Re-Wait	
Loop disconnection detection dead band	14:Upper/Lower Limit Deviation Alert with Re-Wait	
Process alarm alert output enable/disable setting	15:Upper Limit Deviation Alert (Use Set Value (SV) Setting Value)	
Process alarm lower limit	16:Lower Limit Deviation Alert (Use Set Value (SV) Setting Value)	
	17:Upper/Lower Limit Deviation Alert (Use Set Value (SV) Setting Value)	
	18:Within-Range Alert (Use Set Value (SV) Setting Value)	
	19:Upper Limit Deviation Alert with Wait (Use Set Value (SV) Setting Value)	
	20:Lower Limit Deviation Alert with Wait (Use Set Value (SV) Setting Value)	

Each alert mode for alert 1 to 4 corresponds to alert set value 1 to 4.

(b) Alert set value

Set the value where CH□ Alert 1 (b8 of Un\G5 to Un\G8) to CH□ Alert 4 (b11 of Un\G5 to Un\G8) turns on according to the set alert mode. Up to four values can be set for each channel.

Set values in "Alert set value 1" to "Alert set value 4".

Project window ⇨ [Intelligent Function Module] ⇨ Module name ⇨ [Parameter]

Item	CH1	
Alert set value 1	200 C	0
Alert set value 2	0 C	0
Alert set value 3	200 C	0
Alert set value 4	30 C	0
Alert dead band setting	0.5 %	

Alert set value 1 to 4 corresponds to each alert mode for alert 1 to 4.

(8) Setting the alert dead band

When the temperature process value (PV) or deviation (E) is close to the alert set value, alert status and non-alert status may alternate repeatedly due to inconsistent input.

Such case can be prevented by setting an alert dead band.

(a) Setting method

Set a value on "Alert dead band setting".

🔍 Project window ⇒ [Intelligent Function Module] ⇒ Module name ⇒ [Parameter]

Item	CH1
Alert dead band setting	0.5 %
Number of alert delay	0 Times

Ex. When the alert mode is set to Upper limit input alert (1) (👉 Page 157, Section 8.2.11 (1))

When a value other than 0 (0.0%) is set in Alert dead band setting (Un\G164), the system is put in the alert status when upper limit input becomes equal to or greater than the alert set value. The system is put in the non-alert status when the upper limit falls below the alert dead band (figure on the right).

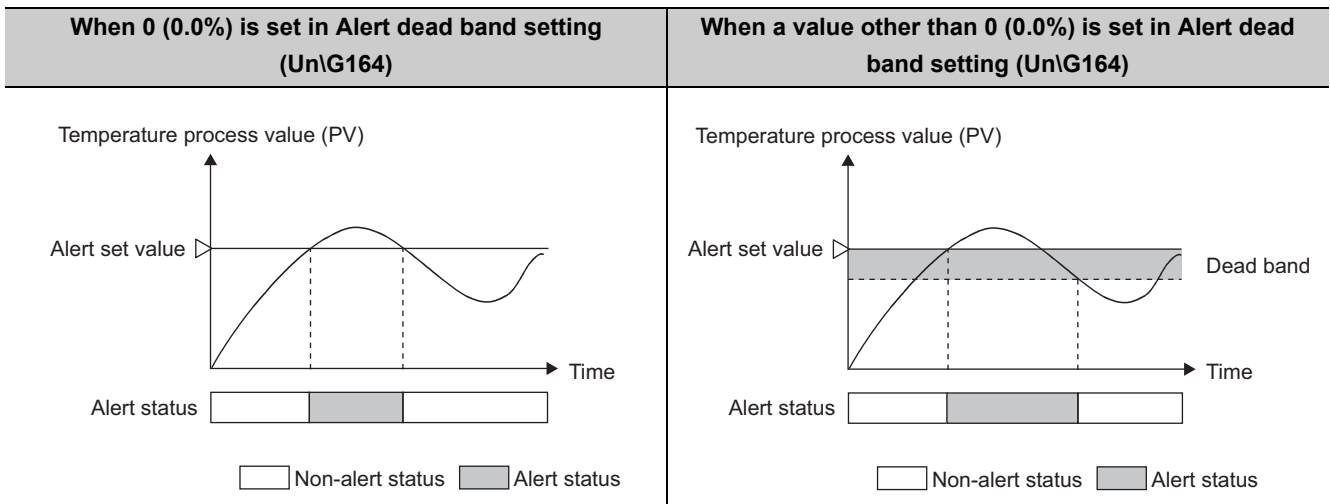

(9) Setting the number of alert delay

Set the number of sampling to judge alert occurrence. The system is set in the alert status when the process value (PV) that has reached the alert set value remains in the alert range until the number of sampling becomes equal to or greater than the preset number of alert delays.

(a) Setting method

Set a value on "Number of alert delay".

🔍 Project window ⇨ [Intelligent Function Module] ⇨ Module name ⇨ [Parameter]

Item	CH1
Number of alert delay	5 Times
Loop disconnection detection	

Ex. When the alert mode is set to Upper limit input alert (1) (👉 Page 157, Section 8.2.11 (1))
 When 5 is set as the number of alert delay, the system is not put in the alert status if the number of sampling is 4 or less.

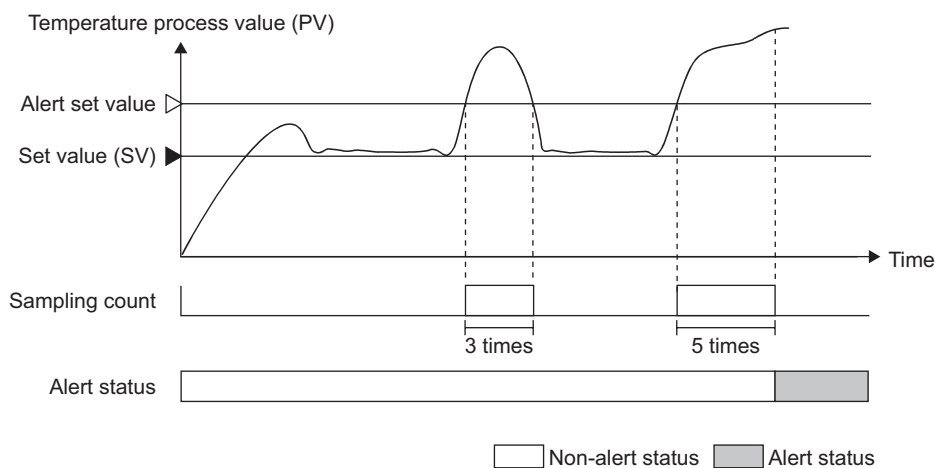

(10) Alert mode and settings

The following table shows the alert modes and validity/availability of related settings.

(Active/Yes: ○, Inactive/No: —)

Alert		Alert dead band setting (☞ Page 168, Section 8.2.11 (8))	Number of alert delay (☞ Page 169, Section 8.2.11 (9))	Alert with standby (☞ Page 163, Section 8.2.11 (3))	Alert with standby (second time) (☞ Page 164, Section 8.2.11 (4))
Input alert	Upper limit input alert (☞ Page 157, Section 8.2.11 (1))	○	○	○	—
	Lower limit input alert (☞ Page 157, Section 8.2.11 (1))	○	○	○	—
Deviation alert	Upper limit deviation alert (☞ Page 159, Section 8.2.11 (2) (b))	○	○	○	○
	Upper limit deviation alert (using the set value (SV)) (☞ Page 159, Section 8.2.11 (2) (b))	○	○	○	○
	Lower limit deviation alert (☞ Page 160, Section 8.2.11 (2) (c))	○	○	○	○
	Lower limit deviation alert (using the set value (SV)) (☞ Page 160, Section 8.2.11 (2) (c))	○	○	○	○
	Upper lower limit deviation alert (☞ Page 160, Section 8.2.11 (2) (d))	○	○	○	○
	Upper lower limit deviation alert (using the set value (SV)) (☞ Page 160, Section 8.2.11 (2) (d))	○	○	○	○
	Within-range alert (☞ Page 161, Section 8.2.11 (2) (e))	○	○	—	—
	Within-range alert (using the set value (SV)) (☞ Page 161, Section 8.2.11 (2) (e))	○	○	—	—

8.2.12 RFB Limiter Function

Standard Heating-cooling

The RFB (reset feed back) function operates when deviation (E) continues for a long period of time. In such occasion, this function limits the PID operation result (manipulated value (MV)) from an integral action so that it does not exceed the valid range of the manipulated value (MV).

This function operates automatically on execution of PID control; therefore, a setting by the user is unnecessary.

Remark

When the PID operation result exceeds the upper limit output limiter value, the L60TC4 operates as follows:

- The RFB function levels the manipulated value (MV) to the upper limit output limiter value by feeding back the exceeded value to the integral value.

When the PID operation result is below the lower limit output limiter value, the L60TC4 operates as follows:

- The RFB function levels the manipulated value (MV) to the lower limit output limiter value by feeding back the lacking value to the integral value.

8.2.13 Input/output (with another analog module) function

Standard Heating-cooling

Input and output can be processed using other analog modules (such as an A/D converter module or D/A converter module) in the system.

(1) Input

In general, a temperature control module uses the temperature measured through thermocouples or platinum resistance thermometers connected to the module as a temperature process value (PV).

In the L60TC4, the digital input value of current or voltage converted by other analog modules (such as an A/D converter module) in the system can also be used as a temperature process value (PV).

(a) Setting method

Follow the procedure below.

1. Select "Input range" from one of "201:Input with Another Analog Module Measured Temperature Range (0 to 4000)" to "205:Input with Another Analog Module Measured Temperature Range (0 to 32000)".

 Project window ⇨ [Intelligent Function Module] ⇨ Module name ⇨ [Parameter]

Item	CH1	CH2
Basic setting	Set the temperature conversion system.	
Input range	2:ThermocoupleK Measured Temperature Range(0 to 1300 C)	2:ThermocoupleK Measured Temperature Range(0 to 1300 C)
Set value (SV) setting	201:Input with Another Analog Module Measured Temperature Range (0 to 4000)	
Unused channel setting	202:Input with Another Analog Module Measured Temperature Range (0 to 12000)	
Conversion enable/disable setting	203:Input with Another Analog Module Measured Temperature Range (0 to 16000)	
Control basic parameter setting	204:Input with Another Analog Module Measured Temperature Range (0 to 4000)	
	205:Input with Another Analog Module Measured Temperature Range (0 to 32000)	

2. Store the value of another analog module (such as an A/D converter module) into CH□ Temperature process value (PV) for input with another analog module (Un\G689 to Un\G692). Store the value of another analog module (such as an A/D converter module) into CH□ Temperature process value (PV) for input with another analog module. (Un\G689 to Un\G692)
 Page 402, Appendix 2 (74))

Point

- If the second procedure above is executed ahead of the first procedure, a write data error (error code: □□□4_H) occurs.
 - When this function is used, the value in the following buffer memory area is used for the temperature process value (PV) scaling function.
 - CH□ Temperature process value (PV) for input with another analog module (Un\G689 to Un\G692)
- For details on the temperature process value (PV) scaling function, refer to the following.

 Page 221, Section 8.3.1

(2) Output

Instead of the transistor output from the temperature control module, analog output values from other analog modules (such as a D/A converter module) can be used as the manipulated value (MV).

(a) Setting method

Follow the procedure below (for the standard control).

1. Select the value on "Resolution of the manipulated value for output with another analog module".

 Project window ⇨ [Intelligent Function Module] ⇨ Module name ⇨ [Parameter]

Resolution of the manipulated value for output with another analog module	0:0 to 4000
Choose any of the following four different	0:0 to 4000 1:0 to 12000 2:0 to 16000 3:0 to 20000

2. Store the value in CH□ Manipulated value (MV) for output with another analog module (Un\G177 to Un\G180) into the buffer memory in other analog module (such as a D/A converter module).

 Page 383, Appendix 2 (47))

Point

- When the manipulated value (MV) is -5.0% to 0.0%, 0 is stored in Manipulated value (MV) for output with another analog module. When the manipulated value (MV) is 100.0% to 105.0%, 4000/12000/16000/20000 is stored in Manipulated value (MV) for output with another analog module.
- The manipulated value (MV) in a percentage value is stored into Manipulated value (MV) for output with another analog module (digital output value) in real time.

8.2.14 ON delay output function

Standard Heating-cooling

This function allows the user to set the delay (response/scan time delay) of transistor output. By setting a delay, and monitoring the ON delay output flag and external output on the program, disconnection of external output can be judged. The following figure is an example using the ON delay flag.

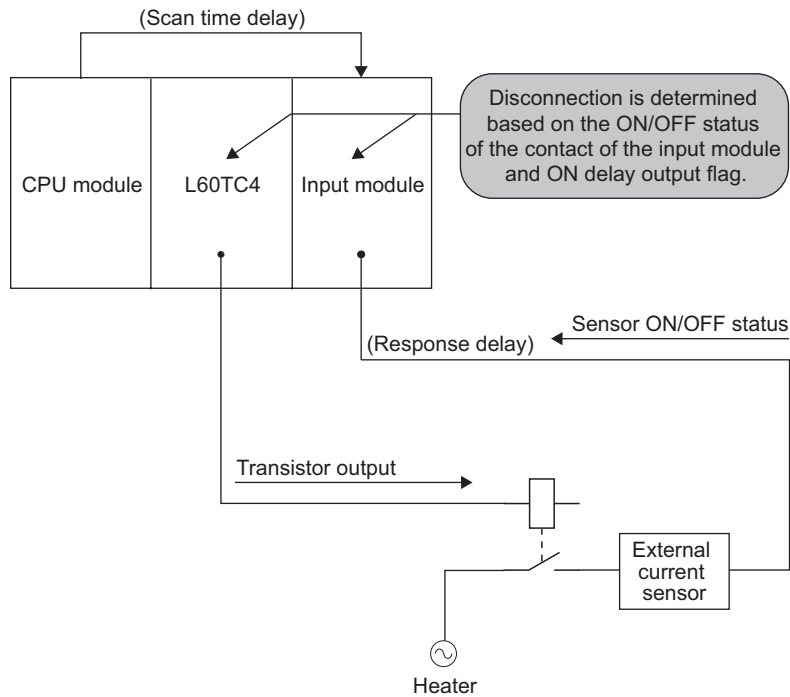

(1) Setting method

Set a value on "Transistor output monitor ON delay time setting".

Project window ⇨ [Intelligent Function Module] ⇨ Module name ⇨ [Parameter]

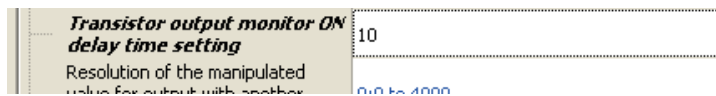

8.2.15 Self-tuning function

Standard

The L60TC4 constantly monitors the control state. When the control system is oscillatory, this function allows PID constants to be automatically changed under the following situations such as:

- After the control has been just started
- When the set value (SV) is changed
- When the characteristics of a controlled object fluctuates

Unlike the auto tuning function, a normal control response waveform is monitored and PID constants are automatically calculated and set. This allows an object to be controlled with the most suitable PID constants all the time without disturbance.

(1) Differences between auto tuning and self-tuning

The following table lists the differences between auto tuning and self-tuning.

Item	Auto tuning	Self-tuning
PID constants calculation	The manipulated value (MV) is turned on/off and PID constants are calculated based on the hunting cycle and amplitude of the temperature process value (PV) for the set value (SV).	PID constants are calculated based on an oscillation occurred under situations such as after the control has been just started, the set value (SV) has been changed, and when a control response is oscillatory.
Execution method	Turning off and on CH□ Auto tuning instruction (Yn4 to Yn7) starts auto tuning and changes PID constants upon completion.	The L60TC4 constantly monitors the control response. PID constants are calculated and changed when the control response is slow.
Control response	PID constants are calculated based on the control response of when the manipulated value (MV) is turned on/off; therefore, the control may become unstable.	PID constants are calculated based on the control response during temperature control; therefore, the control is stable.
Calculation result	The optimum PID constants are calculated by one tuning. In the standard control, CH□ Loop disconnection detection judgment time (Un\G59, Un\G91, Un\G123, Un\G155) is also calculated.	The optimum PID constants may not be obtained by one tuning. CH□ Loop disconnection detection judgment time (Un\G59, Un\G91, Un\G123, Un\G155) is not calculated.
PID constants setting when the characteristics of a controlled object fluctuate	Users perform auto tuning again to change PID constants.	The L60TC4 automatically changes PID constants.
Available control mode	The standard control and heating-cooling control	The standard control only

(2) Starting ST and vibration ST

Two types of self-tuning are available depending on the state of the control system: starting ST (self-tuning) and vibration ST.

- Starting ST: Self-tuning is performed immediately after the control is started or when the set value (SV) is changed.
- Vibration ST: Self-tuning is performed when the control system in a stable state has become oscillatory due to reasons such as disturbance.

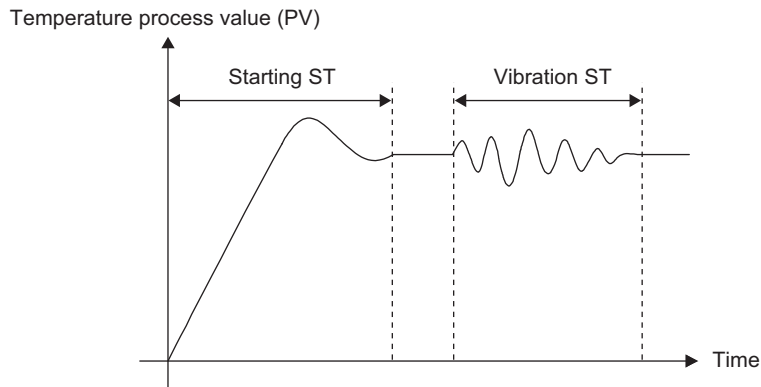

(a) How to set starting ST

Select one of the following four setting values for "Self-tuning setting".

- 1: Starting ST (PID Constant Only)
- 2: Starting ST (Simultaneous Temperature Rise Parameter Only)
- 3: Starting ST (PID Constant and Simultaneous Temperature Rise Parameter)
- 4: Starting ST plus Vibration ST (PID Constant Only)

Project window ⇨ [Intelligent Function Module] ⇨ Module name ⇨ [Parameter]

Item	CH1	CH2	CH3
Self-tuning setting	0:Do Not Run the ST	0:Do Not Run the ST	0:Do Not Run the ST
Temperature conversion setting	0:Do Not Run the ST		
Cooling method setting	1:Starting ST (PID Constant Only)		
Cooling upper limit output limiter	2:Starting ST (Simultaneous Temperature Rise Parameter Only)		
Cooling control output cycle setting	3:Starting ST (PID Constant and Simultaneous Temperature Rise Parameter)		
	4:Starting ST plus Vibration (PID Constant Only)		

(b) How to set vibration ST

Set the following for "Self-tuning setting".

- 4: Starting ST plus Vibration ST (PID Constant Only)

Project window ⇨ [Intelligent Function Module] ⇨ Module name ⇨ [Parameter]

Item	CH1	CH2	CH3
Self-tuning setting	0:Do Not Run the ST	0:Do Not Run the ST	0:Do Not Run the ST
Temperature conversion setting	0:Do Not Run the ST		
Cooling method setting	1:Starting ST (PID Constant Only)		
Cooling upper limit output limiter	2:Starting ST (Simultaneous Temperature Rise Parameter Only)		
Cooling control output cycle setting	3:Starting ST (PID Constant and Simultaneous Temperature Rise Parameter)		
	4:Starting ST plus Vibration (PID Constant Only)		

(3) Procedure for the self-tuning control

The following is the flow chart for the control.

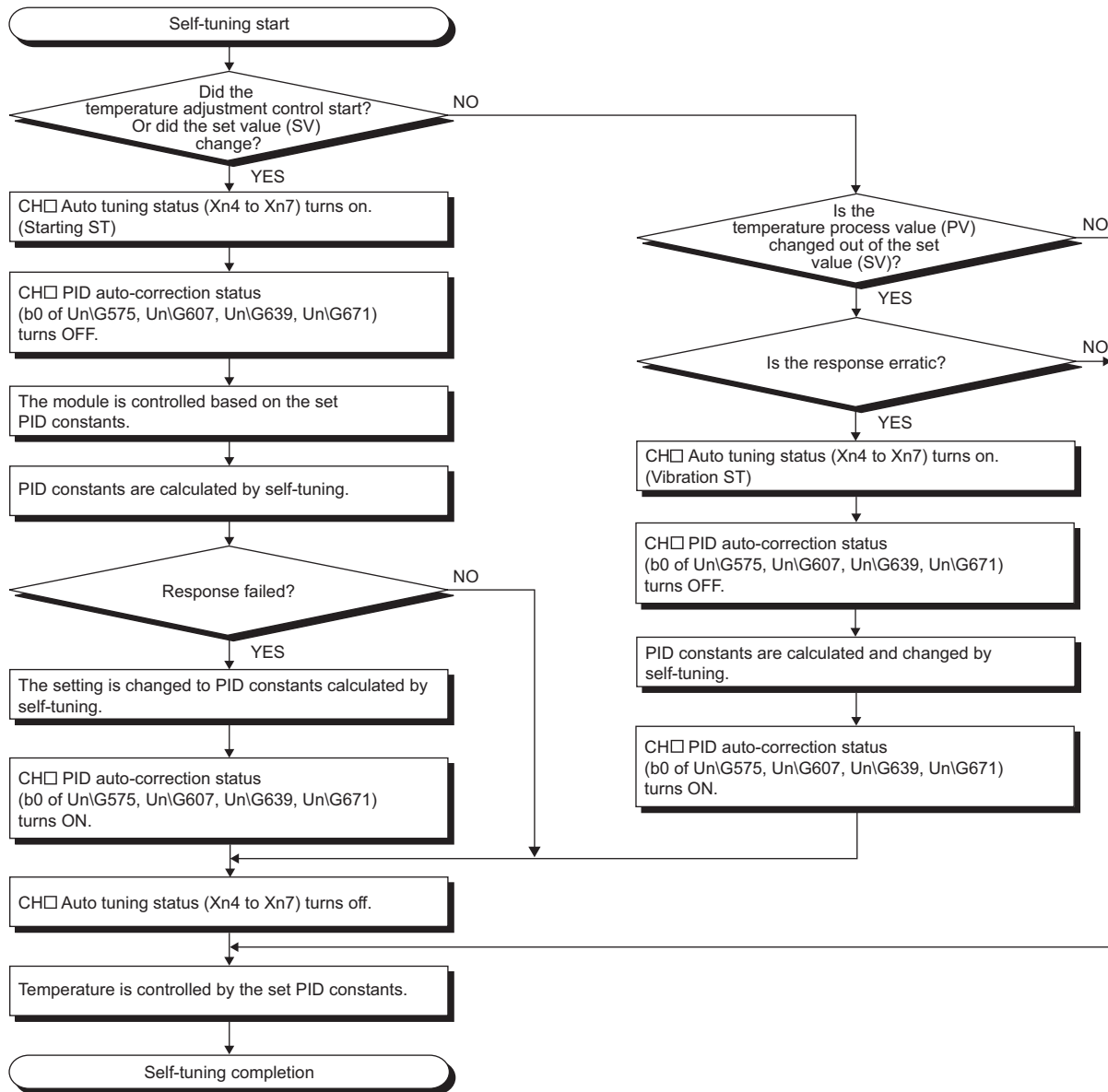

(4) Operation with starting ST

This section explains the operation of when the temperature control is started or the set value (SV) is changed (starting ST).

With starting ST, the module monitors the response waveform of the temperature process value (PV) of when the temperature control is started or when the set value (SV) is changed. Then PID constants are automatically corrected. The following table lists the operations of the module with starting ST.

Operation with starting ST	
1	CH□ PID auto-correction status (b0 of Un\G575, Un\G607, Un\G639, Un\G671) is turned 0 (OFF). In addition, CH□ Auto tuning status (Xn4 to Xn7) is turned on.
2	Temperature is controlled using the PID constants set.
3	When a control response is poor, PID constants are calculated based on the response waveform and are set in the buffer memory. In addition, CH□ PID auto-correction status (b0 of Un\G575, Un\G607, Un\G639, Un\G671) is turned 1 (ON). When a control response is good, CH□ PID auto-correction status (b0 of Un\G575, Un\G607, Un\G639, Un\G671) remains 0 (OFF) and PID constants are not changed.
4	CH□ Auto tuning status (Xn4 to Xn7) is turned off.

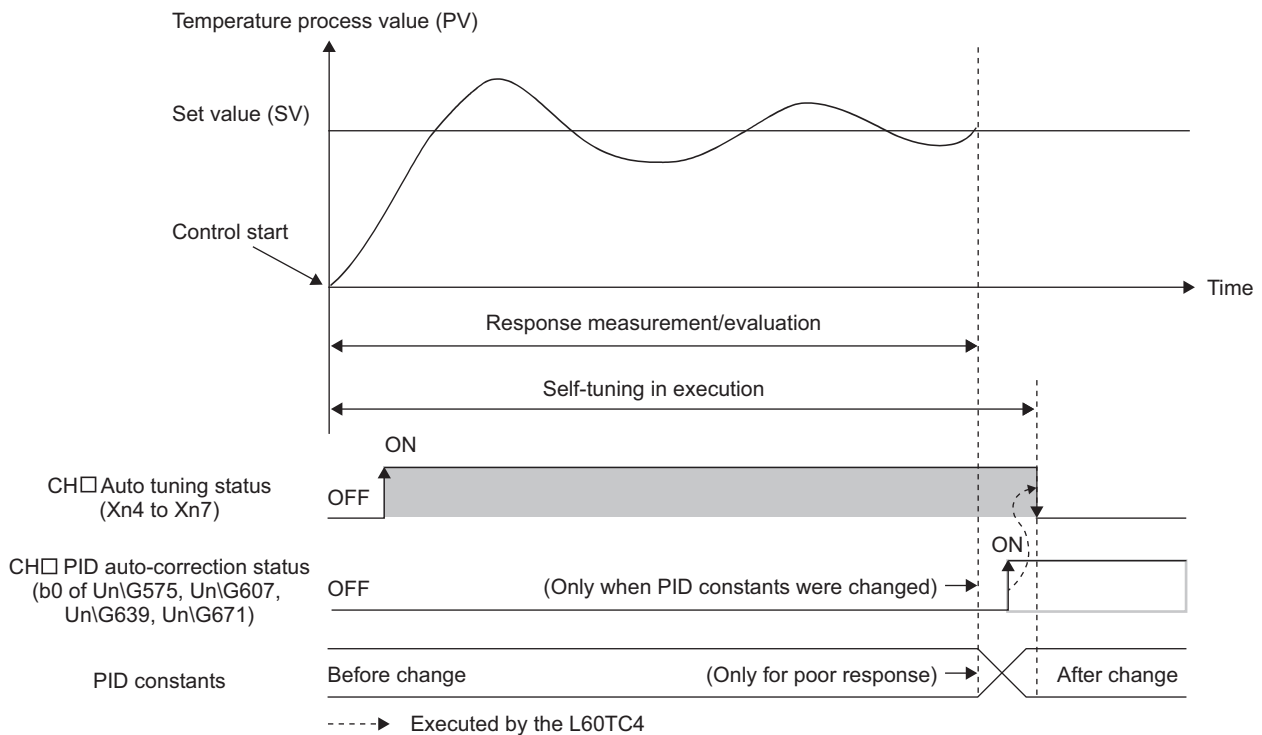

(a) Conditions for self-tuning (starting ST)

Self-tuning is executed under the following conditions:

- When the setting mode is shifted to the operation mode (Setting/operation mode instruction (Yn1) is turned off and on) the first time after the power is turned off and on or after the CPU module is reset and the reset is cancelled
- When the setting mode is shifted to the operation mode the second time or later after the power is turned off and on or after the CPU module is reset and the reset is cancelled (only when the temperature process value (PV) has been stable for two minutes or longer before the mode is shifted)
- When the set value (SV) is changed (only when the set value (SV) after the change is greater than that before the change and when the temperature process value (PV) before the change has been stable for two minutes or longer)

Point 

If the starting ST is started when the temperature process value (PV) is not stable, incorrect PID constants may be determined. Execute the starting ST after the temperature process value (PV) has been stable for two minutes or longer.

(5) Operation with vibration ST

This section explains the operation of when a control response is oscillatory (vibration ST).

With vibration ST, PID constants are automatically corrected to settle a vibration when a control response becomes oscillatory due to reasons such as the change in the characteristic of a controlled object and conditions for operation.

The following table lists the operations of the module with vibration ST. (The listed operations are those under the state where temperature is being controlled with the PID constants set.)

Operation with vibration ST	
1	CH□ PID auto-correction status (b0 of Un\G575, Un\G607, Un\G639, Un\G671) is turned 0 (OFF). In addition, CH□ Auto tuning status (Xn4 to Xn7) is turned on.
2	PID constants are calculated based on a response waveform.
3	PID constants are set in the buffer memory and CH□ PID auto-correction status (b0 of Un\G575, Un\G607, Un\G639, Un\G671) is turned 1 (ON).
4	CH□ Auto tuning status (Xn4 to Xn7) is turned off.

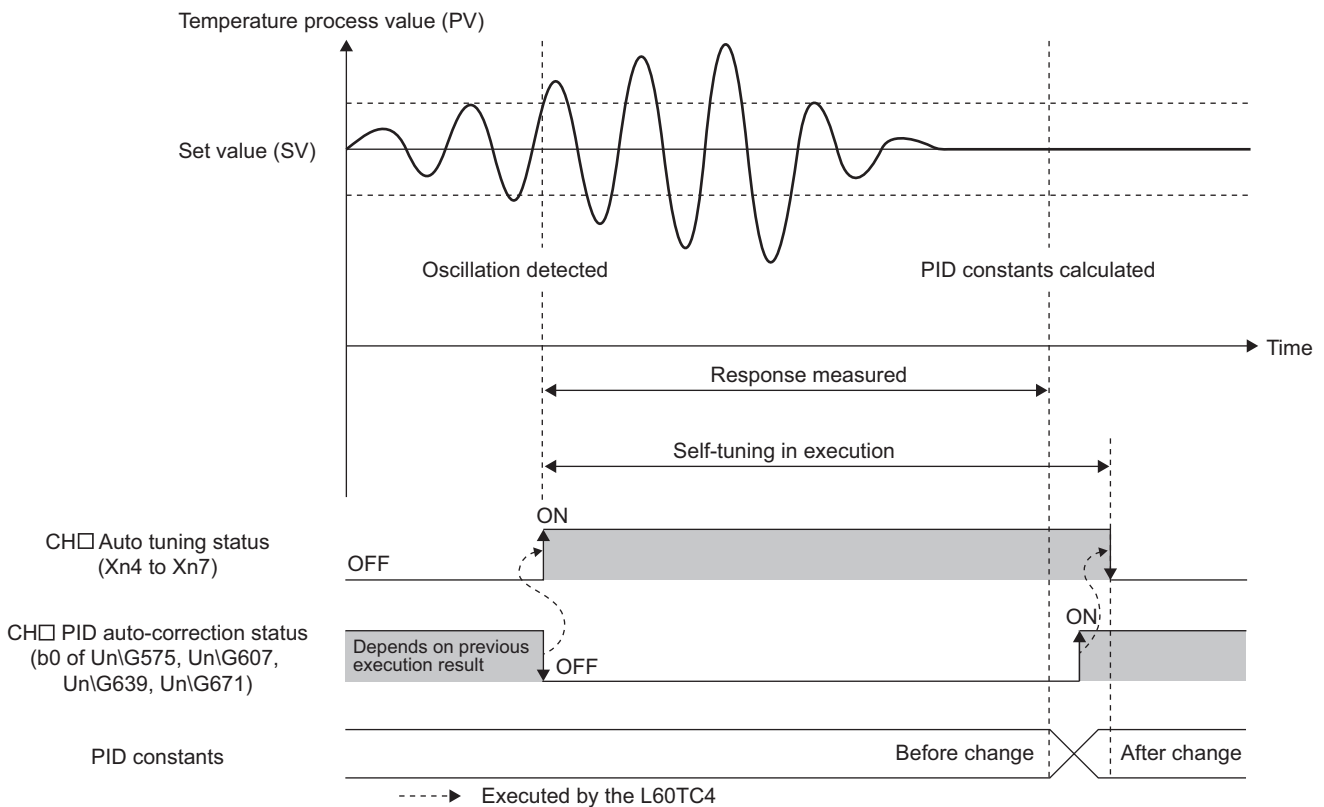

(a) Conditions for self-tuning (vibration ST)

Self-tuning is executed when the temperature process value (PV) goes outside the range that is judged as unstable.

(b) Precautions

If self-tuning (vibration ST) is executed on the following objects, incorrect PID constants may be determined:

- Controlled objects where a disturbance periodically occurs
- Controlled objects with strong mutual interference

(6) Conditions where self-tuning is not executed

This section explains the conditions where self-tuning is not executed.

(a) The control method is not the PID control method

When the control method is one of the methods other than the PID control method (two-position control, P control, PI control, PD control), the following is operated.

- CH□ Self-tuning disable status (b8 of Un\G575, Un\G607, Un\G639, Un\G671) turns 1 (ON).

When all PID constants of target channels turn to a value other than 0, self-tuning is enabled.

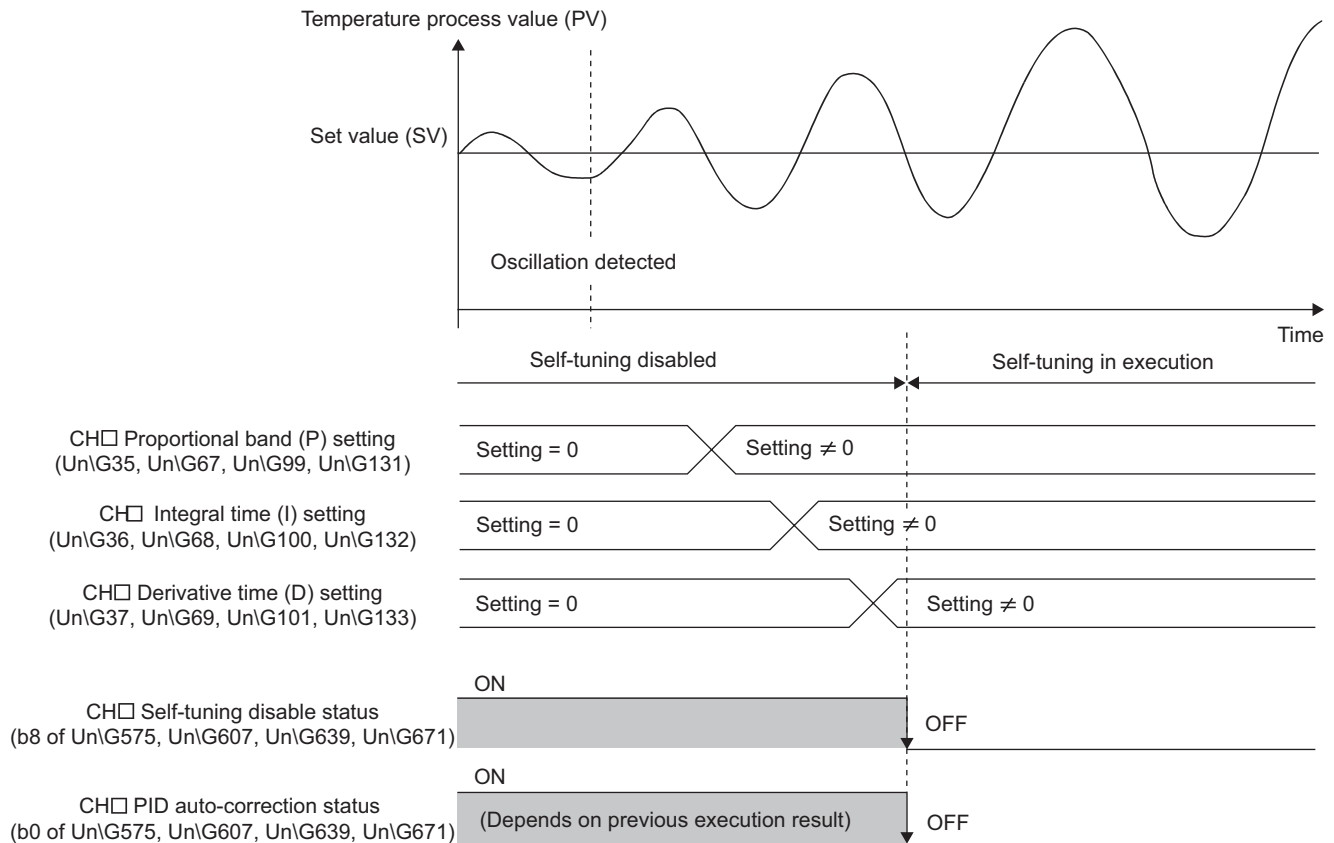

(b) Auto tuning is being executed

At the time of when auto tuning is completed, self-tuning is enabled. An error does not occur.

(c) The lower limit output limiter value is lower than the manipulated value (MV) and the manipulated value (MV) is lower than the upper limit output limiter value when the temperature control is started and the set value (SV) is changed

The starting ST does not start. However, self-tuning is enabled at the time of when a control response becomes oscillatory under the following setting.

- CH□ Self-tuning setting (Un\G574, Un\G606, Un\G638, Un\G670) is set to Starting ST and vibration ST (4).

(d) The manipulated value (MV) is not changed from the lower limit output limiter value or upper limit output limiter value when the temperature control is started and the set value (SV) is changed

The starting ST does not start. However, self-tuning is enabled at the time of when a control response becomes oscillatory under the following setting.

- CH□ Self-tuning setting (Un\G574, Un\G606, Un\G638, Un\G670) is set to Starting ST plus Vibration ST (4).

(e) The temperature process value (PV) is not within the temperature measurement range

CH□ Self-tuning disable status (b8 of Un\G575, Un\G607, Un\G639, Un\G671) turns 1 (ON).

(f) The value set in CH□ Output variation limiter setting (Un\G44, Un\G76, Un\G108, Un\G140) is not 0 (☞ Page 362, Appendix 2 (20))

CH□ Self-tuning disable status (b8 of Un\G575, Un\G607, Un\G639, Un\G671) turns 1 (ON).

(g) CH□ AUTO/MAN mode shift (Un\G50, Un\G82, Un\G114, Un\G146) is set to MAN (1) (☞ Page 367, Appendix 2 (26))

CH□ Self-tuning disable status (b8 of Un\G575, Un\G607, Un\G639, Un\G671) turns 1 (ON).

(h) Other conditions

In addition to those described above, self-tuning is not executed under the following conditions.

- The heating-cooling control has been selected for the control mode. (☞ Page 108, Section 7.2)
- The following buffer memory areas have been set to values other than 0 (0.0%).

Buffer memory area name	Buffer memory address				Reference
	CH1	CH2	CH3	CH4	
CH□ Setting change rate limiter/Setting change rate limiter (temperature rise)	Un\G52	Un\G84	Un\G116	Un\G148	Page 369, Appendix 2 (28)
CH□ Setting change rate limiter (temperature drop)	Un\G564	Un\G596	Un\G628	Un\G660	

(7) Discontinuation of self-tuning

The following operation during self-tuning discontinues the self-tuning operation.

- The setting in CH□ Self-tuning setting (Un\G574, Un\G606, Un\G638, Un\G670) has been changed to Do Not Run the ST (0).

The self-tuning operation in process is discontinued and self-tuning is not performed anymore after that. (An error does not occur.)

Whether self-tuning is being executed can be checked in CH□ Auto tuning status (Xn4 to Xn7). (☞ Page 326, Appendix 1.1 (5))

(8) Conditions where self-tuning does not complete due to errors

The following are the conditions where an error occurs in self-tuning.

- The setting for the buffer memory areas in the following table was changed during self-tuning.

Buffer memory area name	Buffer memory address				Reference
	CH1	CH2	CH3	CH4	
CH□ Proportional band (P) setting	Un\G35	Un\G67	Un\G99	Un\G131	Page 355, Appendix 2 (15)
CH□ Integral time (I) setting	Un\G36	Un\G68	Un\G100	Un\G132	Page 357, Appendix 2 (16)
CH□ Derivative time (D) setting	Un\G37	Un\G69	Un\G101	Un\G133	Page 357, Appendix 2 (17)
CH□ Upper limit output limiter	Un\G42	Un\G74	Un\G106	Un\G138	Page 360, Appendix 2 (19)
CH□ Lower limit output limiter	Un\G43	Un\G75	Un\G107	Un\G139	
CH□ Sensor correction value setting	Un\G45	Un\G77	Un\G109	Un\G141	Page 363, Appendix 2 (21)
CH□ Control output cycle setting	Un\G47	Un\G79	Un\G111	Un\G143	Page 364, Appendix 2 (23)
CH□ Primary delay digital filter setting	Un\G48	Un\G80	Un\G112	Un\G144	Page 365, Appendix 2 (24)
CH□ AUTO/MAN mode shift	Un\G50	Un\G82	Un\G114	Un\G146	Page 367, Appendix 2 (26)
CH□ Setting change rate limiter/Setting change rate limiter (temperature rise)	Un\G52	Un\G84	Un\G116	Un\G148	Page 369, Appendix 2 (28)
CH□ Forward/reverse operation setting	Un\G54	Un\G86	Un\G118	Un\G150	Page 371, Appendix 2 (30)
CH□ Unused channel setting	Un\G61	Un\G93	Un\G125	Un\G157	Page 376, Appendix 2 (35)
CH□ Setting change rate limiter (temperature drop)	Un\G564	Un\G596	Un\G628	Un\G660	Page 369, Appendix 2 (28)

- CH□ Temperature process value (PV) (Un\G9 to Un\G12) is outside the temperature measurement range. (☞ Page 336, Appendix 2 (3))
- The manipulated value (MV) does not reach the upper limit output limiter value or lower limit output limiter value before the measurement is completed and necessary measurement data is not obtained.
- After self-tuning is started with the starting ST, the temperature process value (PV) that is supposed to rise drops by 1°C (°F) or more.
- After self-tuning is started with the starting ST, the temperature process value (PV) that is supposed to drop rises by 1°C (°F) or more.

When an error occurs in self-tuning, CH Self-tuning error (b10 of Un\G575, Un\G607, Un\G639, Un\G671) turns 1 (ON).

(9) Precautions

- Before starting the temperature control using the L60TC4, power on a controlled object such as a heater. If the temperature control is started with a heater powered off, PID constants are calculated based on a response that differs from the original characteristics using self-tuning.

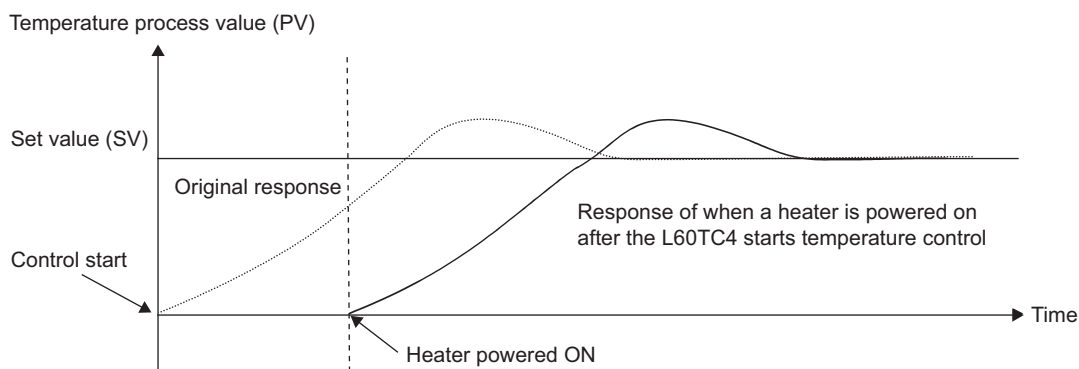

- Do not use the self-tuning function for controlled objects where a great disturbance (uncontrollable disturbance) occurs periodically. Doing so may cause improper PID constants to be determined by self-tuning. If the function is used for such objects, improper PID constants are set and the response for the set value (SV) change or disturbance becomes slow.

Ex. Temperature control for an injection mold, temperature control for a hot plate for a semiconductor manufacturing equipment

(10) To forcibly start up self-tuning

Self-tuning is started up when an error occurs with the control operation; therefore, the forced start-up is not required. To forcibly start up self-tuning, operate the following:

- Set CH□ Control response parameter (Un\G49, Un\G81, Un\G113, Un\G145) to Fast (2). (☞ Page 366, Appendix 2 (25))
- Set CH□ Integral time (I) setting (Un\G36, Un\G68, Un\G100, Un\G132) to a small value. (☞ Page 357, Appendix 2 (16))
- Set CH□ Derivative time (D) setting (Un\G37, Un\G69, Un\G101, Un\G133) to a small value. (☞ Page 357, Appendix 2 (17))

8.2.16 Peak current suppression function

The upper limit output limiter value for each channel is changed automatically and the peak current is suppressed by dividing timing for transistor outputs using this function.

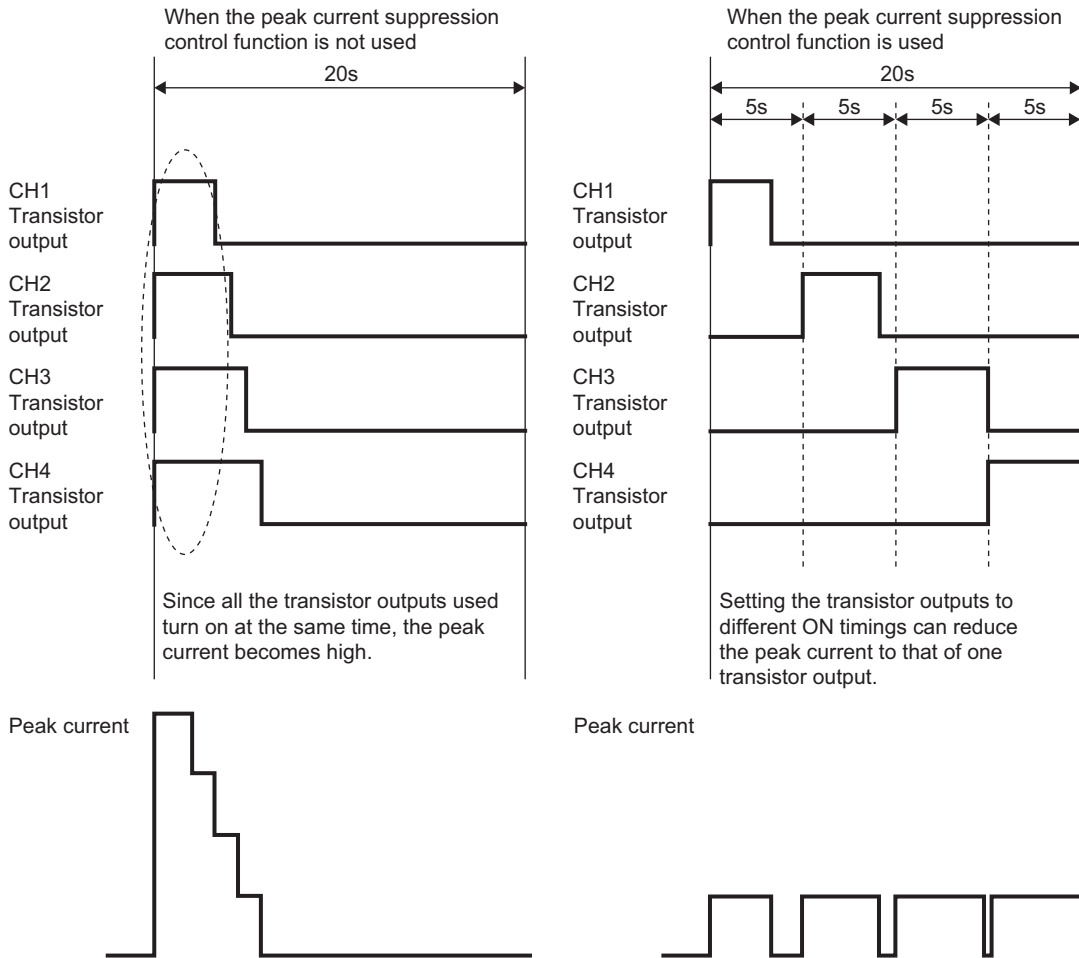

Timing can be divided into two to four timing.

(1) The number of timing divided and upper limit output limiter

Set the number of timing to be divided (setting in Peak current suppression control group setting (Un\G784) in the setting mode (Setting/operation mode status (Xn1): off). The setting is enabled by turning off, on, and off Setting change instruction (YnB). At the time when the setting is enabled, the following buffer memory area is automatically set according to the number of timing divided.

- CH□ Upper limit output limiter (Un\G42, Un\G74, Un\G106, Un\G138) (☞ Page 360, Appendix 2 (19))

The following table lists the setting details.

The no. of timing divided	CH□ Upper limit output limiter (Un\G42, Un\G74, Un\G106, Un\G138)
2	500 (50.0%)
3	333 (33.3%)
4	250 (25.0%)

The following buffer memory area is set to 0.

- CH□ Lower limit output limiter (Un\G43, Un\G75, Un\G107, Un\G139) (☞ Page 360, Appendix 2 (19))

Point

When using this function, set the control output cycles for target channels to the same value. Even if the following buffer memory area setting is different by each channel, an error does not occur.

- CH□ Control output cycle setting (Un\G47, Un\G79, Un\G111, Un\G143) (☞ Page 364, Appendix 2 (23))

The module operates according to the value (%) of CH□ Upper limit output limiter (Un\G42, Un\G74, Un\G106, Un\G138) automatically set when this function is used.

Ex. Timing chart of when timing is divided into four timing

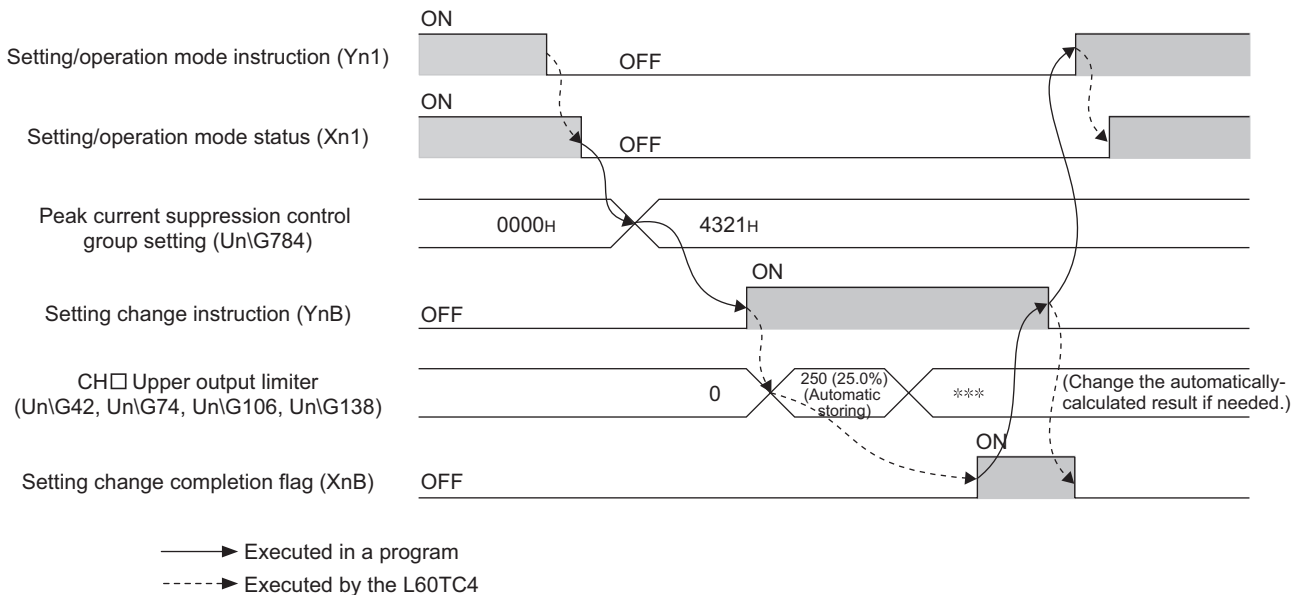

(2) Examples of dividing timing

(a) Four timing

The following table shows two examples.

Example	Channel	Group
Example 1	CH1	Group 1
	CH2	Group 2
	CH3	Group 3
	CH4	Group 4
Example 2	CH1	Group 1
	CH2	Group 2
	CH3	Not divided
	CH4	Group 4

The following shows the relationship between groups and the values (%) of CH□ Upper limit output limiter (UnG42, UnG74, UnG106, UnG138).

Peak current suppression control group setting (UnG784)

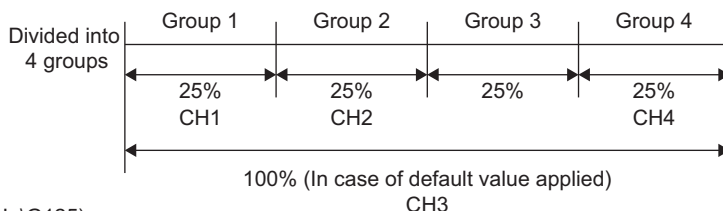
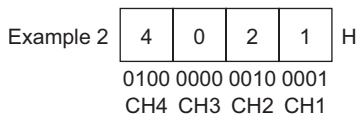
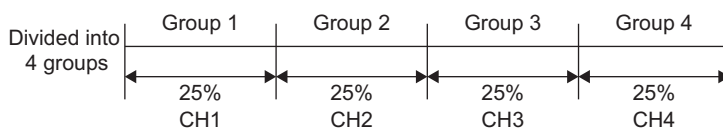
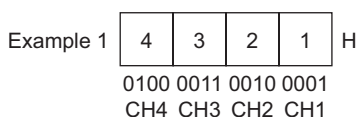

Whether the transistor output is executed or not can be selected by CH3 Unused channel setting (UnG125).

Page 376, Appendix 2 (35)

In Example 2, the maximum number of groups is four; therefore, timing is divided into four timing. Because no channel is set for Group 3, no channel starts transistor output at the timing for Group 3.

(b) Three timing

The following table shows two examples.

Example	Channel	Group
Example 1	CH1	Group 1
	CH2	Group 2
	CH3	Group 2
	CH4	Group 3
Example 2	CH1	Group 1
	CH2	Group 2
	CH3	Group 3
	CH4	Not divided

The following shows the relationship between groups and the values (%) of CH□ Upper limit output limiter (UnG42, UnG74, UnG106, UnG138).

Peak current suppression control group setting (UnG784)

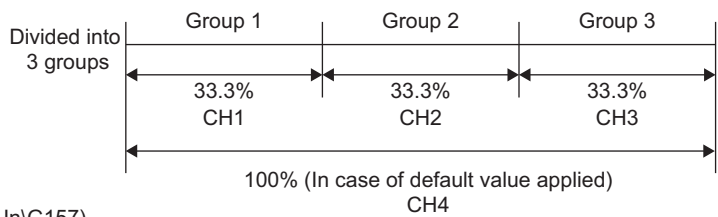
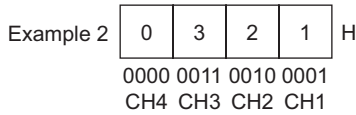
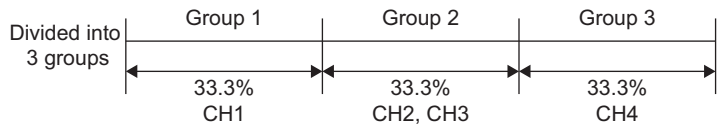
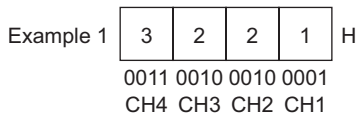

Whether the transistor output is executed or not can be selected by CH4 Unused channel setting (UnG157).

☞ Page 376, Appendix 2 (35)

(c) Two timing

The following table shows two examples.

Example	Channel	Group
Example 1	CH1	Group 1
	CH2	Group 1
	CH3	Group 2
	CH4	Group 2
Example 2	CH1	Group 1
	CH2	Group 2
	CH3	Not divided
	CH4	Not divided

The following shows the relationship between groups and the values (%) of CH□ Upper limit output limiter (Un\G42, Un\G74, Un\G106, Un\G138).

Peak current suppression control group setting (Un\G784)

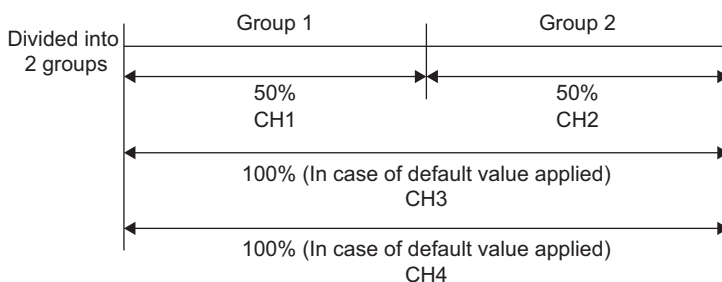
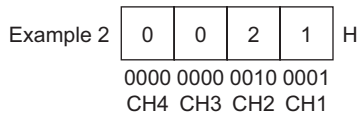
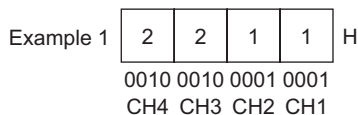

Whether the transistor output is executed or not can be selected by CH3 Unused channel setting (Un\G125) or CH4 Unused channel setting (Un\G157).

☞ Page 376, Appendix 2 (35)

(3) Setting method

Set the timing under "Peak current suppression control group setting".

🖱️ Project window ⇨ [Intelligent Function Module] ⇨ Module name ⇨ [Parameter]

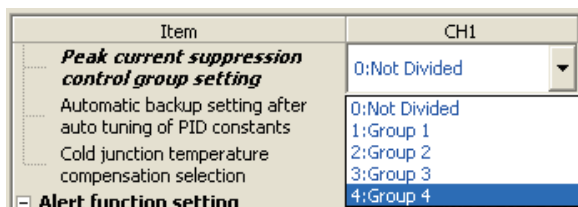

8.2.17 Simultaneous temperature rise function

Standard

This function allows several loops to reach the set value (SV) at the same time. Simultaneous temperature rise can be performed on up to two groups separately by setting a group for the channels to rise at the same time. This function is effective for controlled objects where the temperature rise should complete at the same time. Aligning the time for temperature rise completion can perform even temperature control without partial burning or partial heat expansion. In addition, the channel reaching the set value (SV) first does not need to be kept warm at the set value (SV) until the last channel reaches, leading to energy saving.

Ex. The simultaneous temperature rise function used and not used in CH1

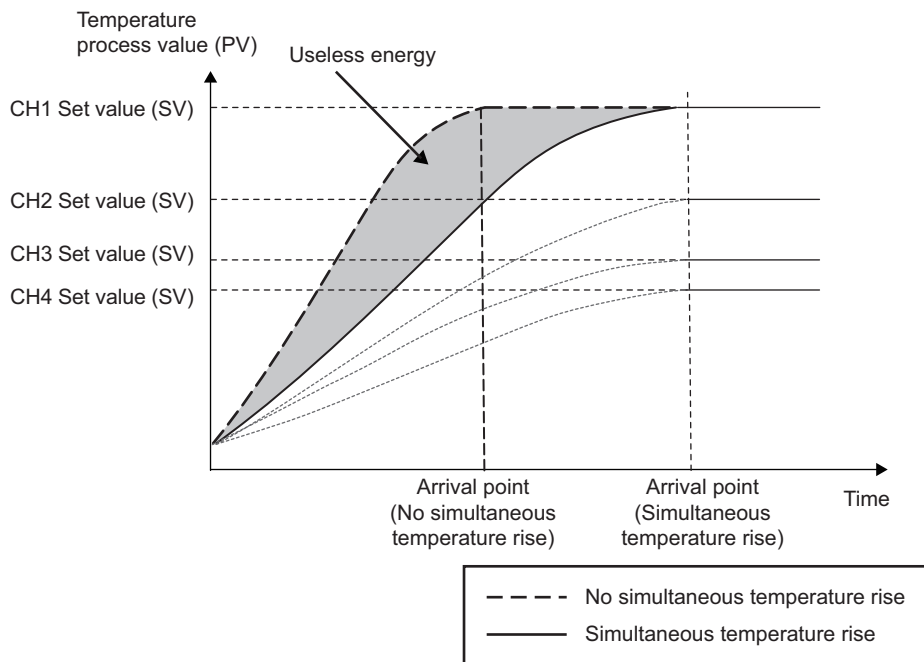

(1) Operation of the simultaneous temperature rise function

The channel with the temperature rise reaching the set value (SV) last among channels satisfying the condition for start-up in the same group is used as a standard when the simultaneous temperature rise function is started up. The temperature of other channels rises following the temperature of the standard channel. The standard channel is determined based on the simultaneous temperature rise parameter and the deviation (E).

Ex. When all channels are selected for Group 1

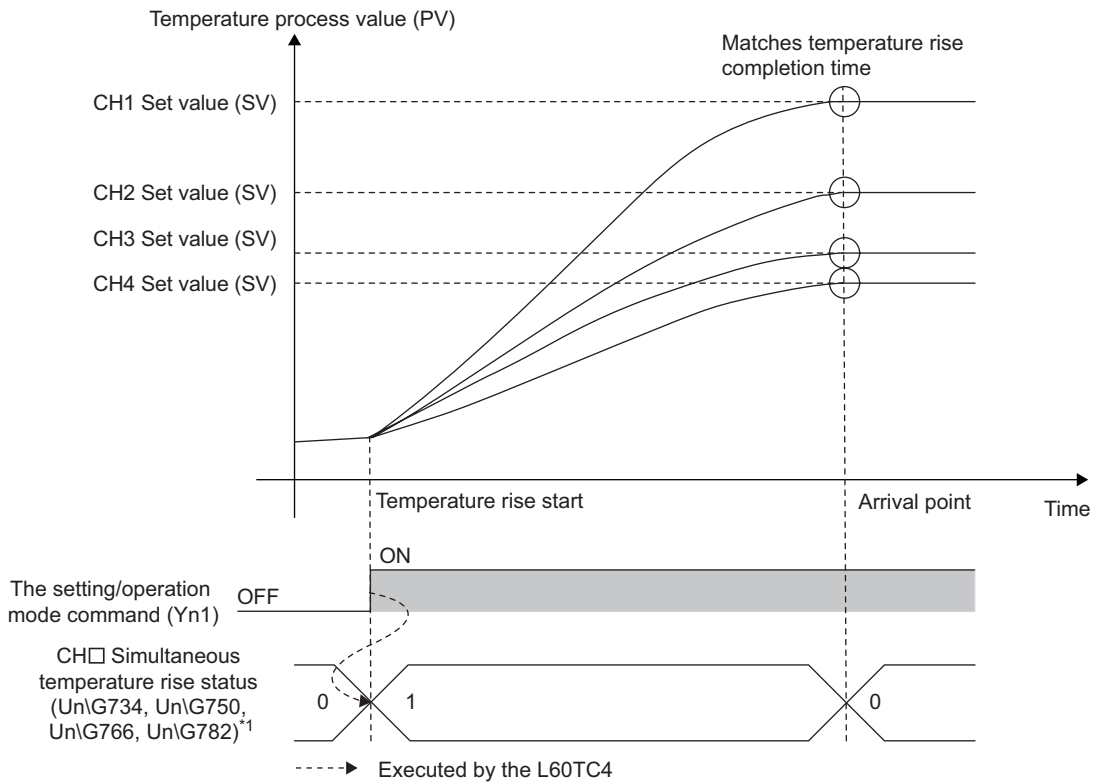

*1 This becomes Simultaneous temperature rise in process (1) when the temperature rise starts; however, it becomes Simultaneous temperature rise not in process (0) before the temperature rise starts.

Ex. When channels are divided as following:

- CH1 and CH2: Group 1
- CH3 and CH4: Group 2

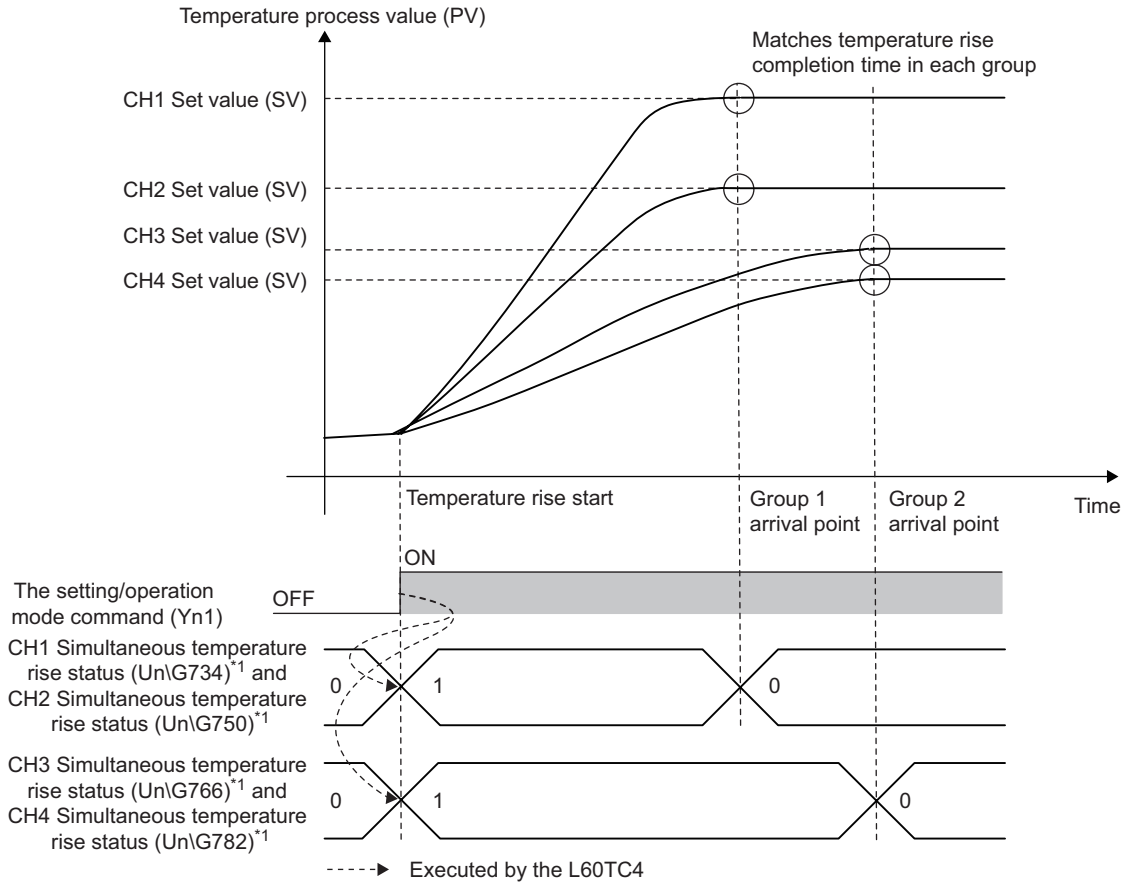

*1 They become Simultaneous temperature rise in process (1) when the temperature rise starts; however, they become Simultaneous temperature rise not in process (0) before the temperature rise starts.

Remark

- When the operation mode is changed to the setting mode (Setting/operation mode instruction (Yn1) is turned on and off) during simultaneous temperature rise, the control is stopped. In addition, CH□ Simultaneous temperature rise status (Un\G734, Un\G750, Un\G766, Un\G782) changes from Simultaneous temperature rise in process (1) to Simultaneous temperature rise not in process (0). (An error does not occur.)
 - When the simultaneous temperature rise function is executed, the setting change rate limiter cannot be used.
- (Page 369, Appendix 2 (28))

(2) Conditions for the simultaneous temperature rise function

The simultaneous temperature rise function is executed when all the following conditions are satisfied:

- When the control is started or the set value (SV) is changed
- When the set value (SV) is larger than the temperature process value (PV)
- When the standard control is selected on Switch Setting (not executed in the heating-cooling control)
( Page 108, Section 7.2)
- When the simultaneous temperature rise parameter has been determined (or has been set) and is not 0 (the default value)

When the following buffer memory area setting is less than 100%, reaching time may vary.

- CH□ Upper limit output limiter (Un\G42, Un\G74, Un\G106, Un\G138) ( Page 360, Appendix 2 (19))

(3) Setting method (dividing channels into groups)

Set the groups under "Simultaneous temperature rise group setting".

 Project window ⇨ [Intelligent Function Module] ⇨ Module name ⇨ [Parameter]

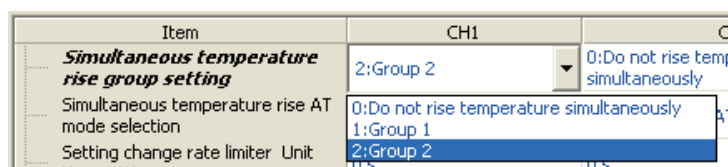

(4) Simultaneous temperature rise parameter



The simultaneous temperature rise parameter is classified into the following two buffer memory values.

Buffer memory area name	Buffer memory address				Reference
	CH1	CH2	CH3	CH4	
CH□ Simultaneous temperature rise gradient data	Un\G731	Un\G747	Un\G763	Un\G779	Page 408, Appendix 2 (85)
CH□ Simultaneous temperature rise dead time	Un\G732	Un\G748	Un\G764	Un\G780	Page 408, Appendix 2 (86)

Before executing the simultaneous temperature rise function, the simultaneous temperature rise parameter needs to be automatically calculated (or arbitrarily set).

(a) Automatic calculation

The simultaneous temperature rise parameter can be automatically calculated using the following two methods:

- Simultaneous temperature rise AT ( Page 194, Section 8.2.17 (5))
- Simultaneous temperature rise parameter setting using self-tuning ( Page 197, Section 8.2.17 (6))

Point

If the setting in Peak current suppression control group setting (Un\G784) is changed after the simultaneous temperature rise parameter is calculated, the intended control may not be performed. If so, calculate the simultaneous temperature rise parameter again.

For details on the peak current suppression function, refer to the following.

 Page 185, Section 8.2.16

(5) Simultaneous temperature rise AT

PID constants and the simultaneous temperature rise parameter are calculated. The waveform upon execution is the same as that for the auto tuning function.

For details on the auto tuning function, refer to the following.

Page 141, Section 8.2.7

(a) How to execute the simultaneous temperature rise AT function

Follow the instructions below.

1. Set "1:AT for Simultaneous Temperature Rise" under "Simultaneous temperature rise AT mode selection".

Project window ⇨ [Intelligent Function Module] ⇨ Module name ⇨ [Parameter]

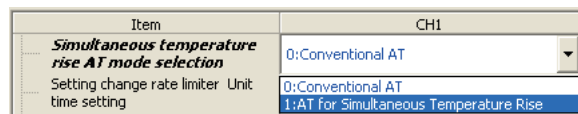

2. Turn off and on CH□ Auto tuning instruction (Yn4 to Yn7).
3. Set the module to the operation mode (turn off and on Setting/operation mode instruction (Yn1).

(b) Operation with the simultaneous temperature rise AT function

After the procedure described on Page 194, Section 8.2.17 (5) (a) is executed, the L60TC4 operates as following.

Operation of the L60TC4	
1	CH□ Auto tuning status (Xn4 to Xn7) is turned on. Then normal auto tuning is performed and the simultaneous temperature rise parameter is calculated.
2	The calculated value is stored in the buffer memory when the simultaneous temperature rise parameter is normally calculated. In addition, CH□ AT simultaneous temperature rise parameter calculation completion (b0 of Un\G573, Un\G605, Un\G637, Un\G669) is turned 1 (ON). After auto-tuning is completed, CH□ Auto tuning status (Xn4 to Xn7) is turned off and the module is shifted to the PID control.

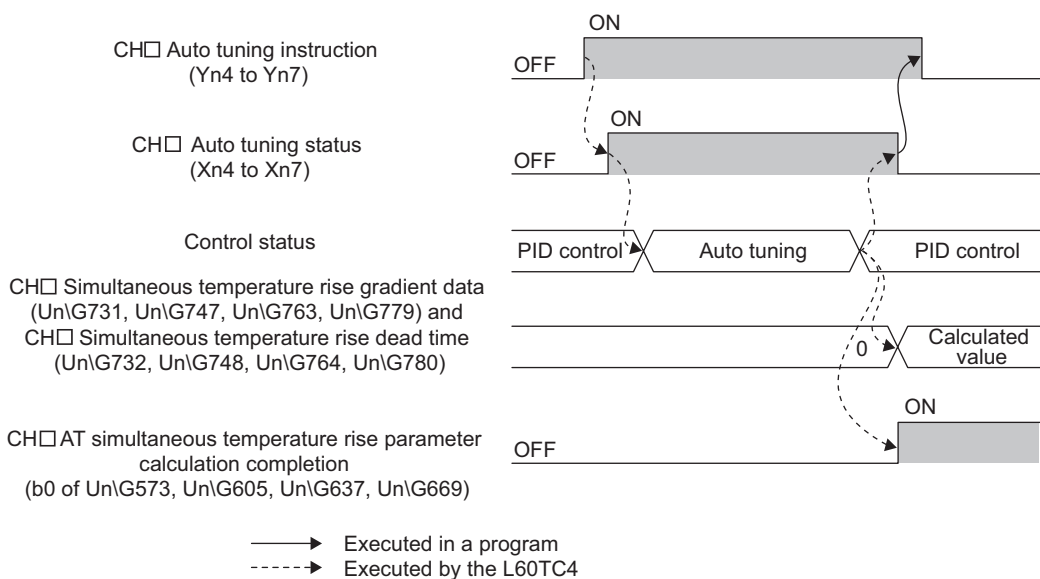

(c) Condition for the simultaneous temperature rise AT

The simultaneous temperature rise parameter is calculated when all the following conditions are satisfied after the procedure described on [Page 194, Section 8.2.17 \(5\) \(a\)](#) is executed:

- When the module is in the PID control (all of the proportional band (P), integral time (I), and derivative time (D) are not 0)
- When the temperature process value (PV) is within the temperature measurement range before the simultaneous temperature rise AT is executed. If the temperature process value (PV) goes outside the range after the simultaneous temperature rise AT is executed, an error occurs with the auto tuning function. For the operation of the L60TC4 in that situation, refer to [Page 151, Section 8.2.7 \(8\) \(b\)](#).
- When CH□ Output variation limiter setting (Un\G44, Un\G76, Un\G108, Un\G140) is set to 0. ([Page 362, Appendix 2 \(20\)](#))

If all the conditions described above are not satisfied, the simultaneous temperature rise parameter is not calculated. Only PID constants are calculated.

The following shows how the L60TC4 operates when the simultaneous temperature rise AT has not been executed.

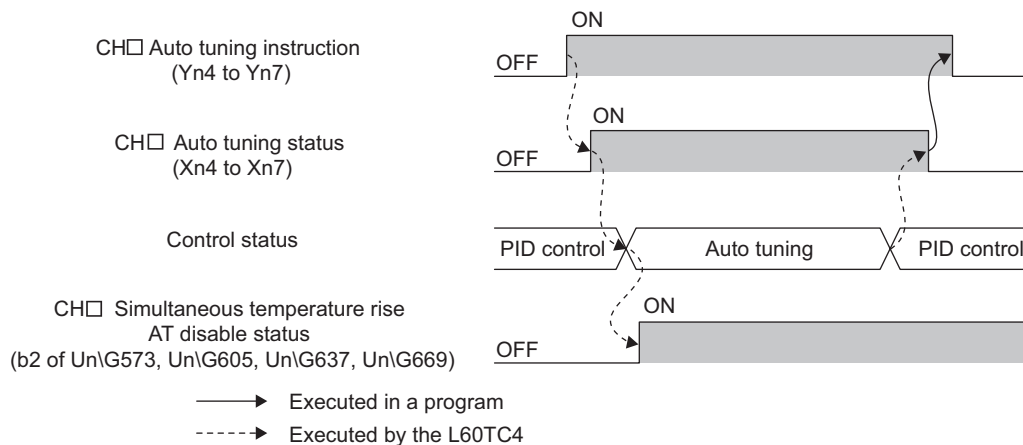

The L60TC4 turns CH□ Simultaneous temperature rise AT disable status (b2 of Un\G573, Un\G605, Un\G637, Un\G669) to 1 (ON). With CH□ Auto tuning status (Xn4 to Xn7) on, the module performs the same processing as normal auto tuning.

(d) When the simultaneous temperature rise parameter cannot be calculated

The simultaneous temperature rise parameter cannot be calculated under the following conditions:

- When the maximum gradient is not determined
- When the saturation time for output is short

The L60TC4 turns CH□ AT simultaneous temperature rise parameter calculation error status (b1 of Un\G573, Un\G605, Un\G637, Un\G669) to 1 (ON).

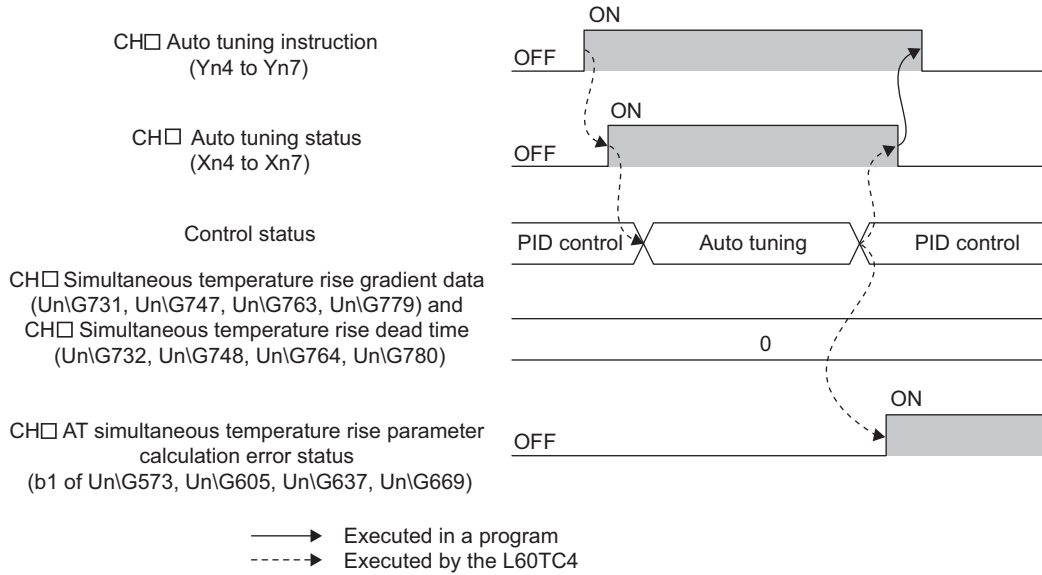

(6) The simultaneous temperature rise parameter setting using self-tuning

The control response at the time of temperature rise is constantly monitored during self-tuning and the simultaneous temperature rise parameter is calculated based on the characteristics of a controlled object. For details on the self-tuning function, refer to the following.

☞ Page 175, Section 8.2.15

(a) Operation with the simultaneous temperature rise parameter setting using self-tuning

The L60TC4 operates as following.

Operation of the L60TC4	
1	When self-tuning is normally started up, CH□ Auto tuning status (Xn4 to Xn7) is turned on and the simultaneous temperature rise parameter is calculated.
2	The calculated value is stored in the buffer memory when the simultaneous temperature rise parameter is normally calculated. Then CH□ Simultaneous temperature rise parameter correction status (b1 of Un\G575, Un\G607, Un\G639, Un\G671) is turned 1 (ON), CH□ Auto tuning status (Xn4 to Xn7) is turned off, and the module is shifted to the PID control.

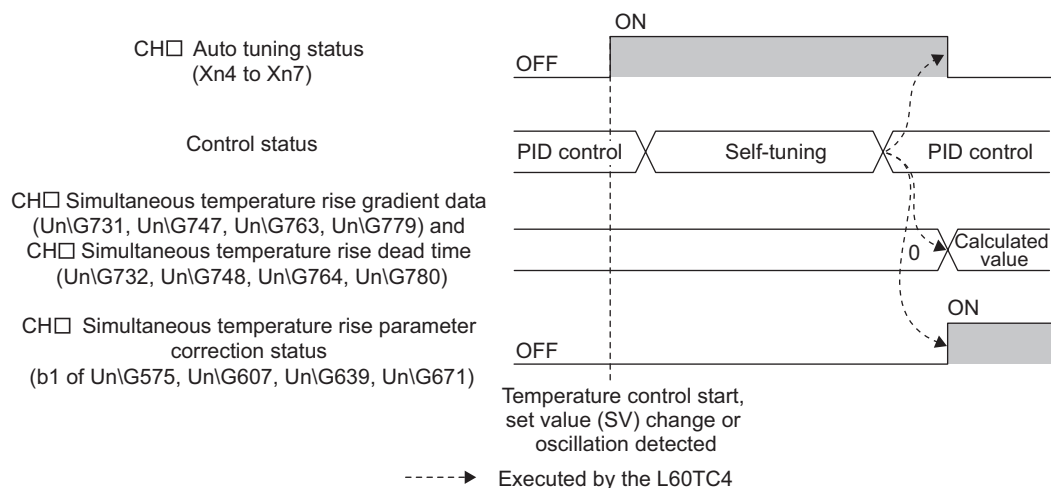

(b) Condition for the simultaneous temperature rise parameter setting using self-tuning

The condition is the same as that for the starting ST. (☞ Page 178, Section 8.2.15 (4) (a))

When the self-tuning cannot be started up, the L60TC4 operates as following with the PID control continued:

- CH□ Self-tuning disable status (b8 of Un\G575, Un\G607, Un\G639, Un\G671) is turned 1 (ON).

The following shows how the L60TC4 operates when self-tuning is not executed.

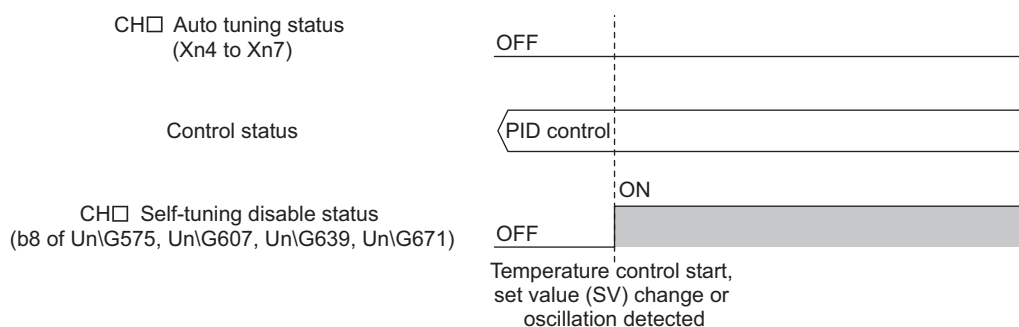

(c) When the simultaneous temperature rise parameter cannot be calculated

The simultaneous temperature rise parameter cannot be calculated under the following conditions:

- When the maximum gradient is not determined
- When the saturation time for output is short

The L60TC4 turns CH□ Simultaneous temperature rise parameter error status (b9 of Un\G575, Un\G607, Un\G639, Un\G671) to 1 (ON).

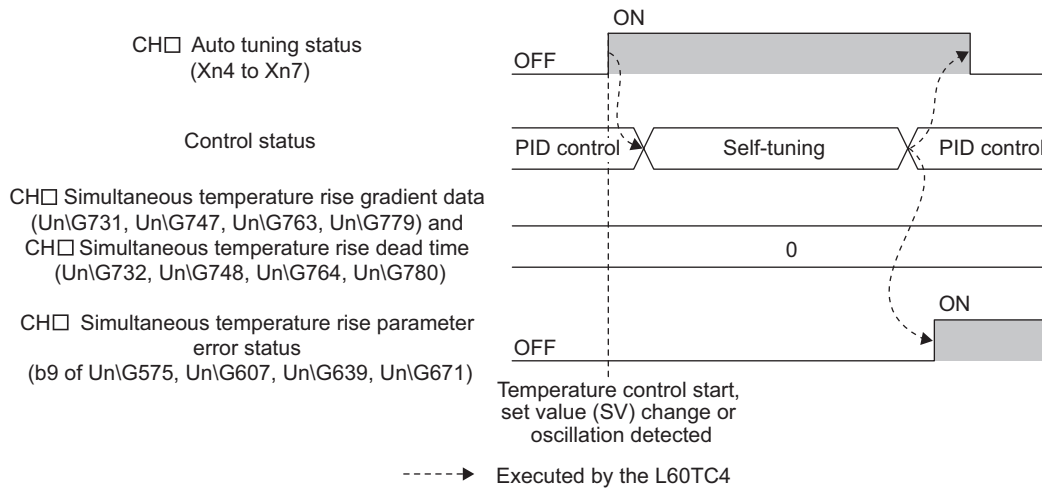

Point

To restore CH□ Simultaneous temperature rise parameter error status (b9 of Un\G575, Un\G607, Un\G639, Un\G671) to 0 (OFF), set the following:

- Set CH□ Self-tuning setting (Un\G574, Un\G606, Un\G638, Un\G670) to Not performing ST (0).

To calculate the simultaneous temperature rise parameter, execute self-tuning again after the temperature has dropped.

(d) Stopping of calculation for the simultaneous temperature rise parameter

The optimum simultaneous temperature rise parameter may not be able to be calculated depending on the characteristics of a controlled object. In addition, the L60TC4 stops calculating the simultaneous temperature rise parameter during self-tuning under the following conditions:

- When the set value (SV) is changed
- When 6000s (1 hour and 40 minutes) or longer has passed after the self-tuning operation is started
- When the change rate of the temperature process value (PV) during self-tuning is less than 1.125 (°C/minute)
- When the setting for CH□ Output variation limiter setting (Un\G44, Un\G76, Un\G108, Un\G140) is changed (☞ Page 362, Appendix 2 (20))

(e) How to set the simultaneous temperature rise parameter using self-tuning

Select one of the following setting values under "Self-tuning setting".

- 2: Starting ST (Simultaneous Temperature Rise Parameter Only)
- 3: Starting ST (PID Constant and Simultaneous Temperature Rise Parameter)

☞ Project window ⇨ [Intelligent Function Module] ⇨ Module name ⇨ [Parameter]

Item	CH1	CH2	
Self-tuning setting	2:Starting ST	0:Do Not Run the ST	0:Do Not Run the
Temperature conversion setting	0:Do Not Run the ST		
Cooling method setting	1:Starting ST (PID Constant Only)		
Cooling upper limit output limiter	2:Starting ST (Simultaneous Temperature Rise Parameter Only)		
Cooling control output cycle setting	3:Starting ST (PID Constant and Simultaneous Temperature Rise Parameter)		
	4:Starting ST plus Vibration (PID Constant Only)		

(7) Operation when the simultaneous temperature rise parameter is calculated with self-tuning and auto tuning

(a) When the simultaneous temperature rise AT is started before the simultaneous temperature rise parameter is calculated with self-tuning

The simultaneous temperature rise parameter is not calculated neither with self-tuning nor auto tuning. PID constants are changed.

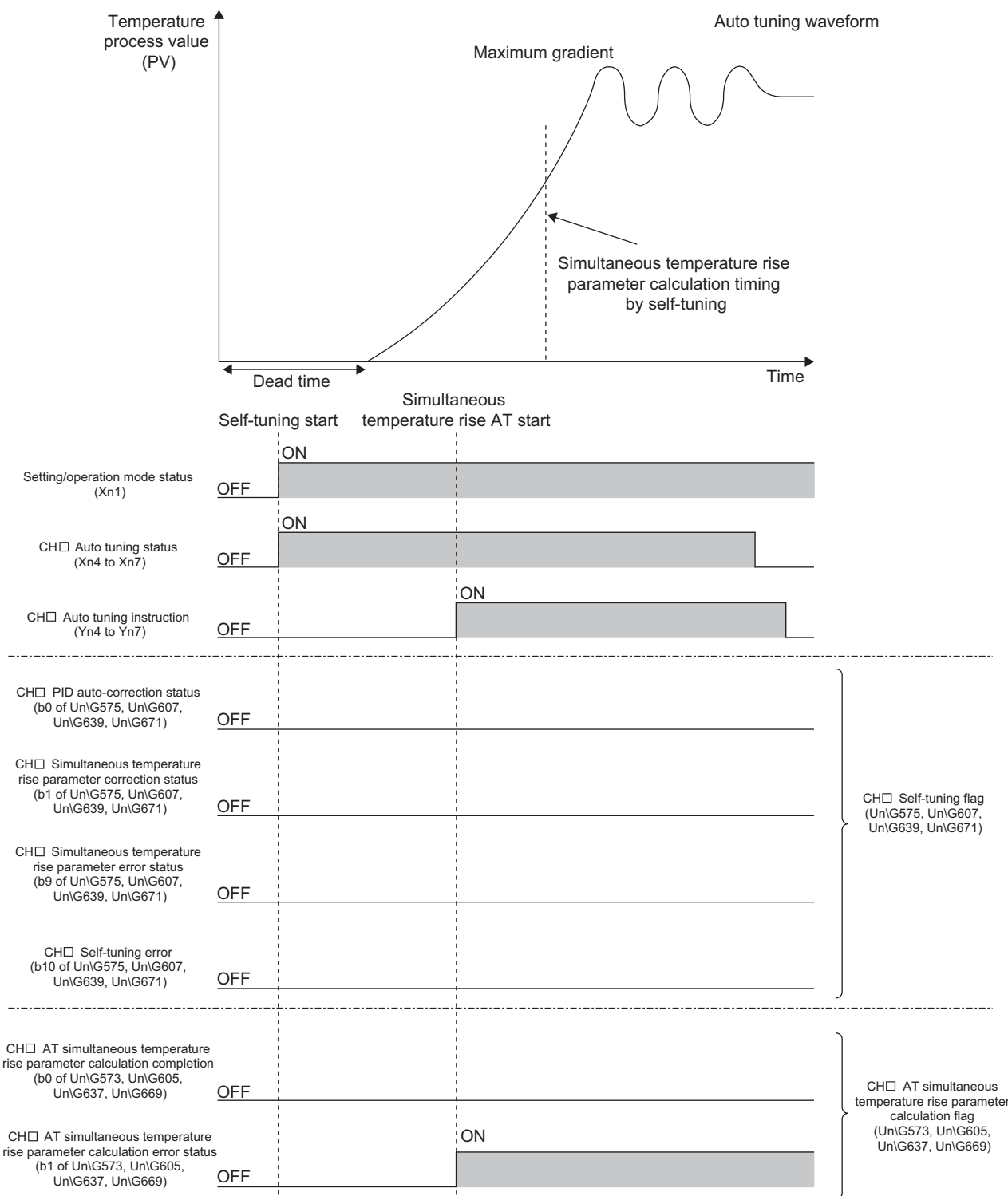

(b) When the simultaneous temperature rise AT is started after the simultaneous temperature rise parameter is calculated with self-tuning

The simultaneous temperature rise parameter calculated with self-tuning is effective. Then PID constants are changed with auto tuning.

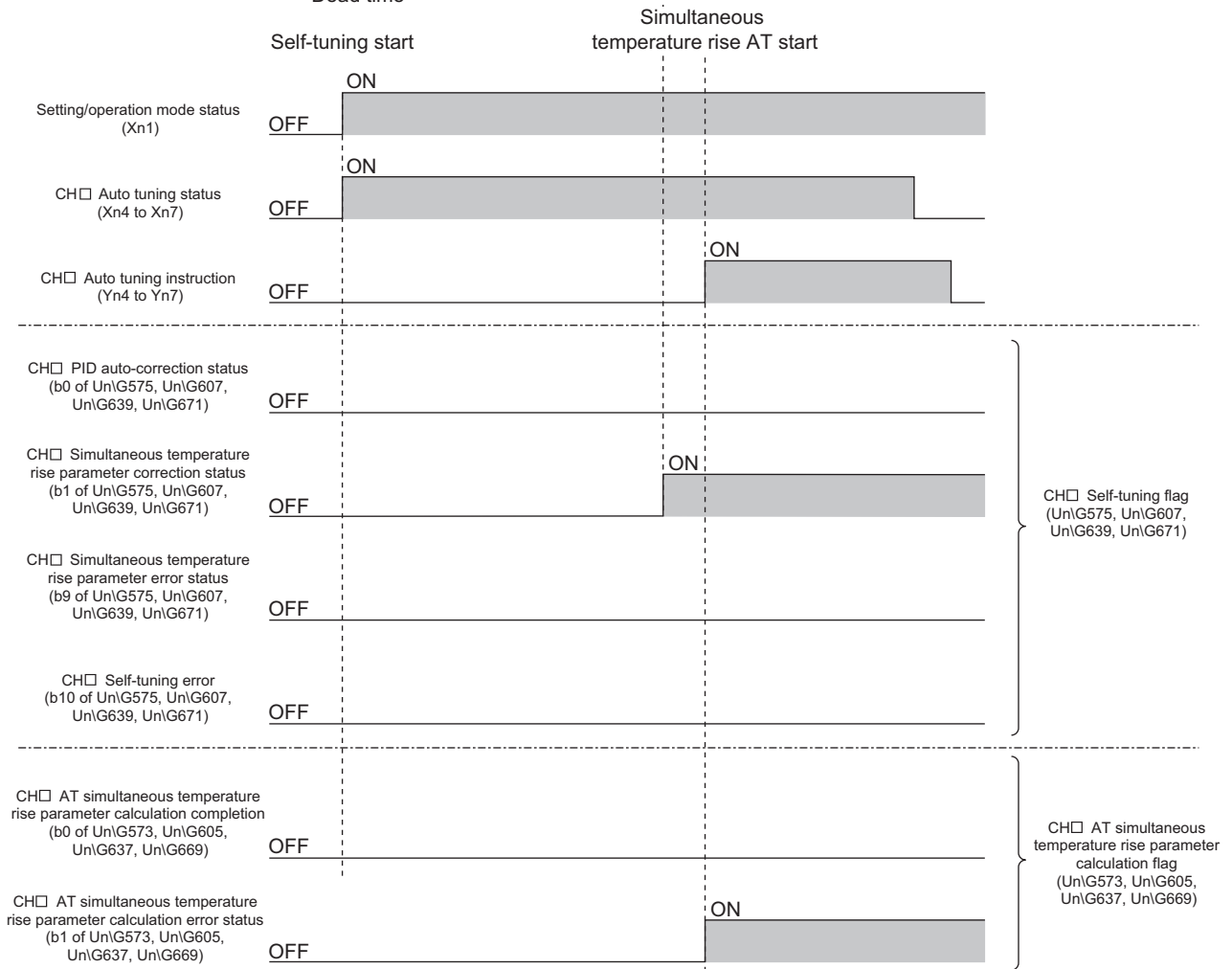
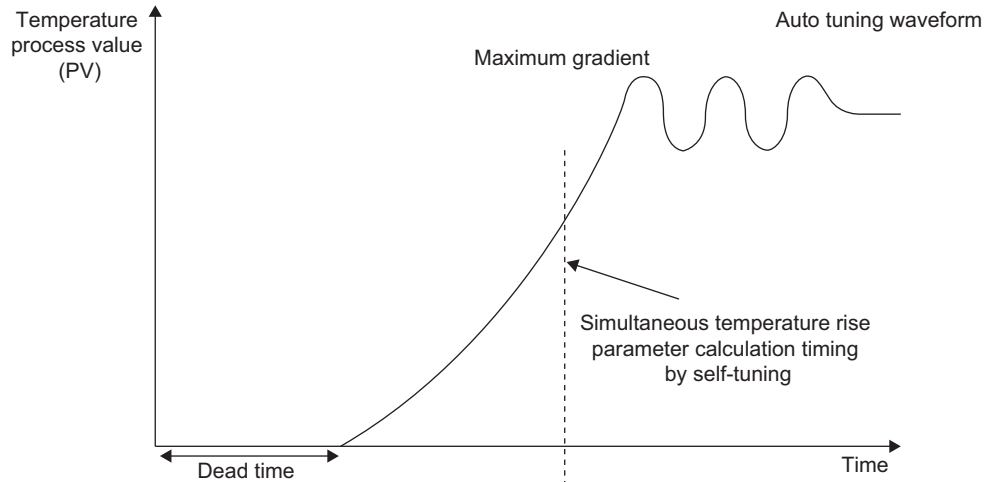

(c) When CH□ Auto tuning instruction (Yn4 to Yn7) is turned off and on in the setting mode and the module is shifted to the operation mode

After the module is shifted to the operation mode (Setting/operation mode instruction (Yn1) is turned off and on), the simultaneous temperature rise parameter and PID constants are changed with auto tuning.

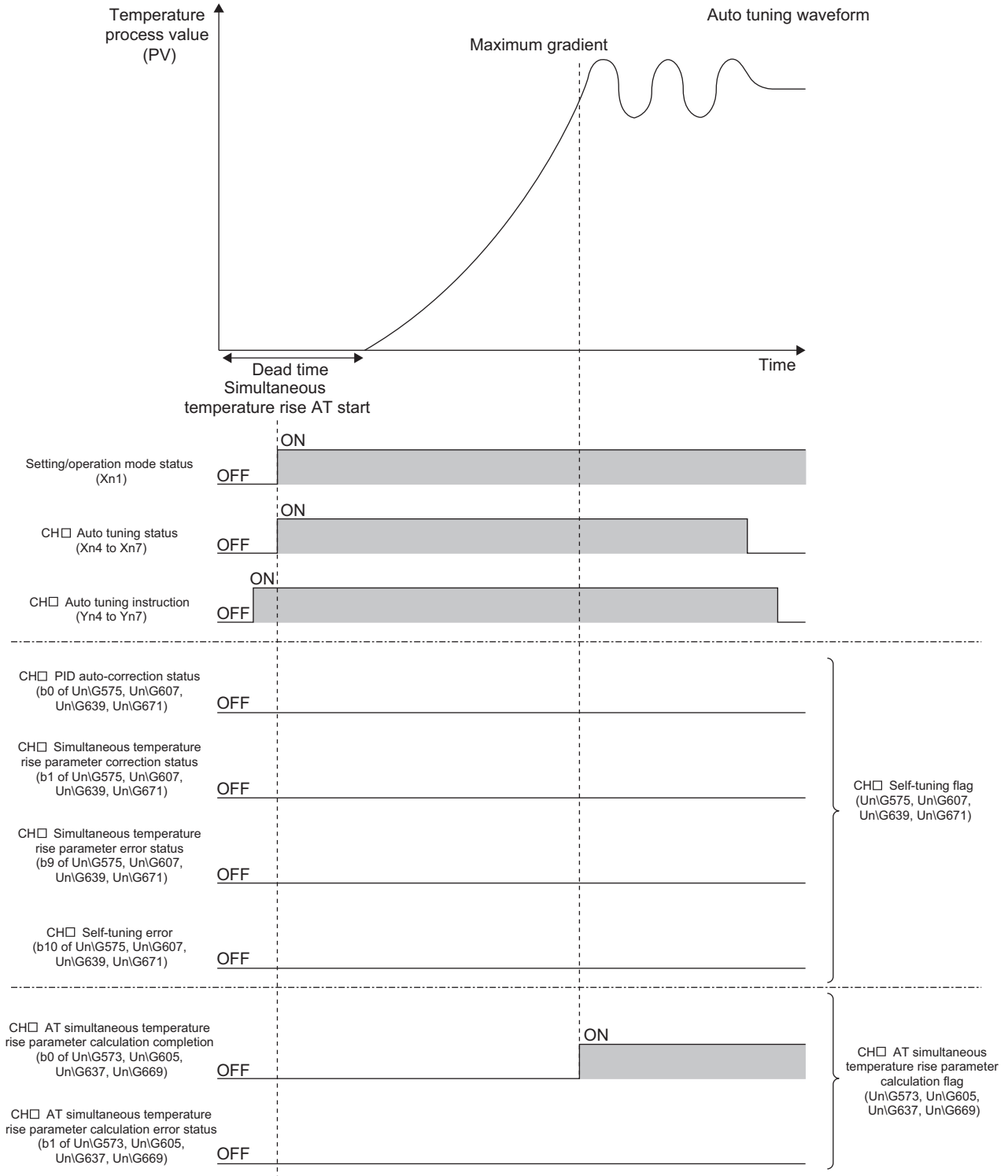

(d) When auto tuning is started with the temperature process value (PV) within the stable judgment width (1°C (°F)) after the setting mode is changed to the operation mode

Until the temperature process value (PV) goes outside the stable judgment width (1°C (°F)), the data measured after the module is shifted to the operation mode (Setting/operation mode instruction (Yn1) is turned off and on) can be used. Therefore, the simultaneous temperature rise parameter can be calculated with auto tuning.

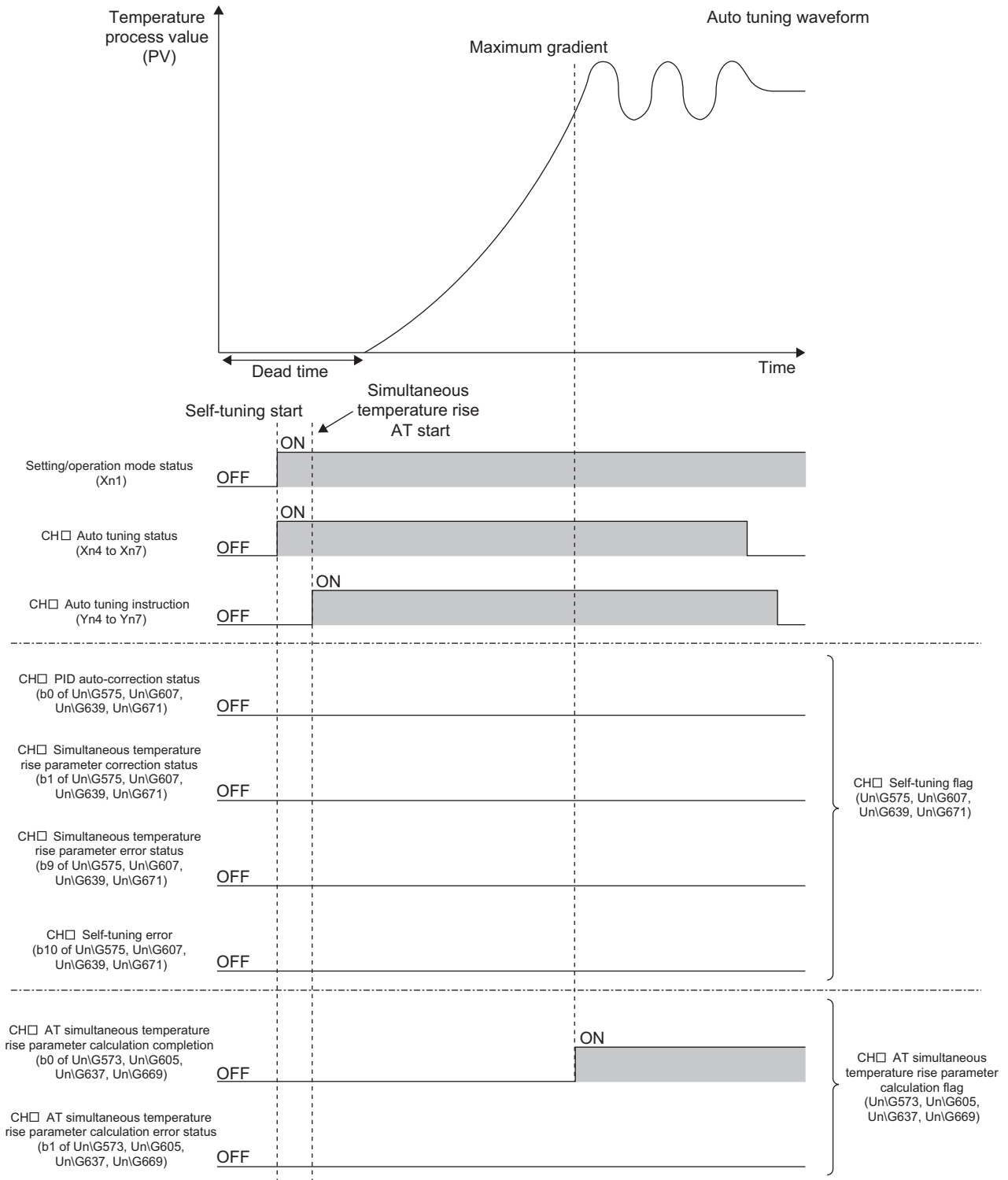

8.2.18 Forward/reverse action selection function

Standard

Whether PID operation is performed with forward action or reverse action can be selected using this function.

This function can be used in all the control methods (two-position control, P control, PI control, PD control, and PID control). (☞ Page 129, Section 8.2.3)

For details on the operation, refer to the following.

☞ Page 24, Section 1.4.2

(1) Setting method

Set the function under "Forward/reverse action setting".

☞ Project window ⇨ [Intelligent Function Module] ⇨ Module name ⇨ [Parameter]

Item	CH1
Control detail parameter setting	The Q64TCTT(BW) allows you l of the above thermocouples.
<i>Forward/reverse action</i>	1:Reverse Action
Upper limit setting limiter	0:Forward Action
Lower limit setting limiter	1:Reverse Action

8.2.19 Loop disconnection detection function

Standard

Using this function detects an error occurring within a control system (control loop) due to reasons such as a load (heater) disconnection, an externally-operable device (such as a magnetic relay) failure, and input disconnection.

(1) How an error is detected

Since the time a PID operation value becomes 100% or 0%, the amount of changes in the temperature process value (PV) is monitored every unit time and disconnection of a heater and input is detected.

(2) Examples of the errors detected

The following are the examples of the errors detected.

(a) When control output is being performed

The L60TC4 detects an error because the temperature does not rise even when control output is being performed under the following conditions:

- When a heater is disconnected
- When input is disconnected or short-circuited
- When the contact point of an externally-operable device does not turn on

After control output is output 100%, an alert is output if the temperature does not rise by 2°C (°F) or more within the loop disconnection detection judgment time set (forward action is changed to reverse action). (Page 203, Section 8.2.18)

(b) When control output is not being performed

The L60TC4 detects an error because the temperature rises even when control output is not being performed under the following conditions:

- When input is disconnected
- When the contact point of an externally-operable device was bonded

After control output drops to 0%, an alert is output if the temperature does not drop by 2°C (°F) or more within the loop disconnection detection judgment time set (forward action is changed to reverse action). (Page 203, Section 8.2.18)

(3) Setting method

Two settings are available for the loop disconnection detection function.

(a) Setting for the unit time to monitor the amount of changes in the temperature process value (PV)

Set the unit time under "Loop disconnection detection judgement time".

Project window ⇒ [Intelligent Function Module] ⇒ Module name ⇒ [Parameter]

Item	CH1
Loop disconnection detection judgment time	480 s
Loop disconnection detection dead	0 s

Point

When not using this function, set CH□ Loop disconnection detection judgment time (Un\G59, Un\G91, Un\G123, Un\G155) to 0.

(b) Setting for the dead band

Set the dead band under "Loop disconnection detection dead band".

 Project window ⇨ [Intelligent Function Module] ⇨ Module name ⇨ [Parameter]

Item	CH1
<i>Loop disconnection detection dead band</i>	30 C
Process alarm dead output	0

Point 

When the loop disconnection detection dead band is set, loop disconnection does not occur even if the temperature does not change by 2°C (°F) or more with the set value (SV) 100% or 0% of control output.

8.2.20 Proportional band setting function

Heating-cooling

Proportional band (P) values can be set for heating and cooling separately using this function. Different gradients can be set by using different proportional band (P) values in a heating and cooling area.

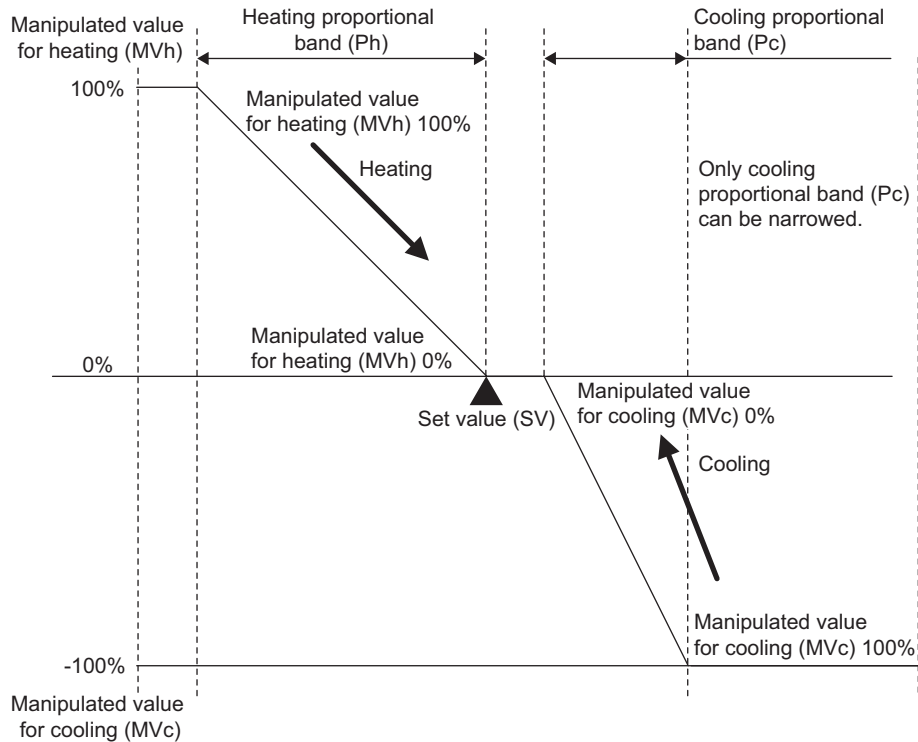

(1) Setting method

(a) For heating

Set the value under "Proportional band (P) setting/Heating control proportional band setting (Ph)".

Project window ⇒ [Intelligent Function Module] ⇒ Module name ⇒ [Parameter]

Item	CH1
Control basic parameter setting	The Q64TC exercises temperat
Proportional band (P) setting/Heating control proportional band setting	3.0 %
Cooling proportional band (Pc)	

(b) For cooling

Set the value under "Cooling proportional band (Pc) setting".

Project window ⇒ [Intelligent Function Module] ⇒ Module name ⇒ [Parameter]

Item	CH1
Cooling proportional band (Pc) setting	3.0 %
Integral time (Ti) setting	240 s

8.2.21 Cooling method setting function

Heating-cooling

An auto tuning calculation formula is automatically selected according to the selected cooling method during auto tuning and the operation is started using this function.

Select one of the following characteristics:

- Air Cooled: The cooling characteristic is nonlinear and cooling ability is low.
- Water Cooled: The cooling characteristic is nonlinear and cooling ability is high.
- Linear: The cooling characteristic is close to the linear shape.

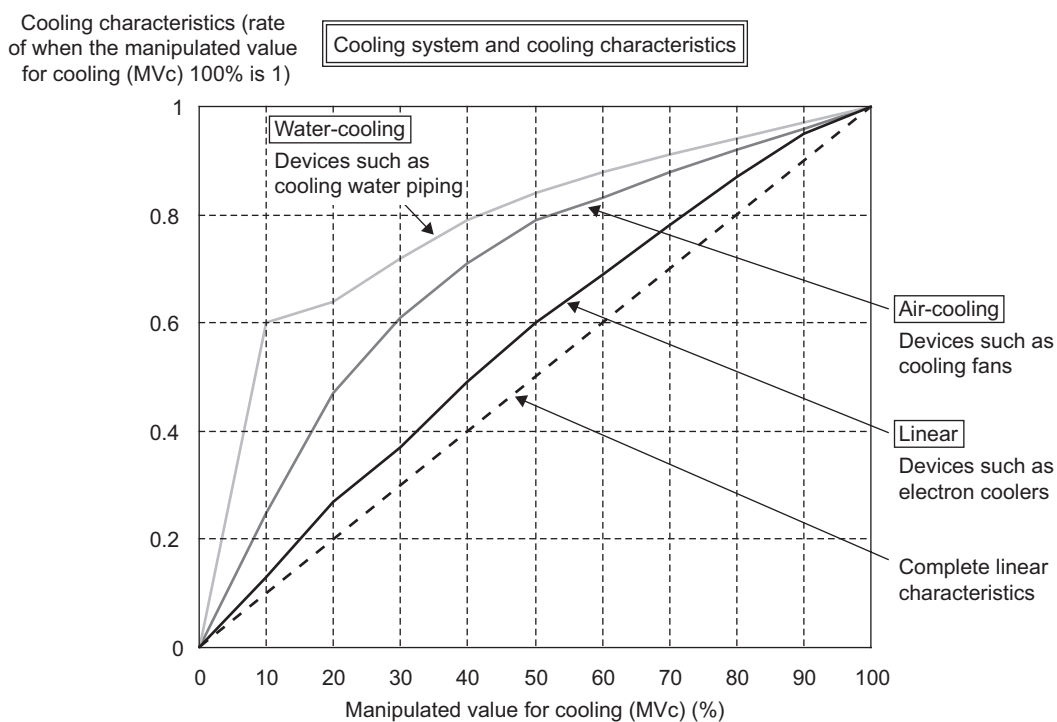

PID constants are calculated and executed based on this setting during auto tuning; therefore, more appropriate PID constants can be found by setting more applicable cooling characteristic of a device.

For details on the auto tuning function, refer to the following.

☞ Page 141, Section 8.2.7

(1) Setting method

Set the characteristic under "Cooling method setting".

 Project window ⇨ [Intelligent Function Module] ⇨ Module name ⇨ [Parameter]

Item	CH1
Cooling method setting	0:Air Cooled
Cooling upper limit output limiter	0:Air Cooled
Cooling control output cycle setting	1:Water Cooled
	2:Linear

Point

- An auto tuning calculation formula to find PID constants is determined based on this setting; therefore, configure this setting before executing auto tuning.
- "Air Cooled" and "Water Cooled" roughly indicate the level of the cooling ability. When a device is too cooled even if it is set to Air Cooled, set the module to Water Cooled (1H). When a device is not very cooled even if it is set to Water Cooled, set the module to Air Cooled (0H).
- In general, the ability of water cooling is higher than that of air cooling and cooling may be too strong if the same PID constants as air cooling are used. Some time is required until the control becomes stable upon the initial start-up, disturbance, or setting change. Therefore, in auto tuning, PID constants for when the module is set to Water Cooled (1H) become larger than those for when the module is set to Air Cooled (0H).

8.2.22 Overlap/dead band function

Heating-cooling

In heating-cooling control, the temperature process value (PV) significantly changes due to slight heating or cooling control output when the heat produced by a controlled object and natural cooling are being balanced. Consequently, excessive output may be performed.

The temperature where the cooling control output starts can be shifted using this function; therefore, whether control stability is prioritized or energy saving is prioritized can be selected.

(1) Overlap

Overlap refers to the temperature area where both of heating control and cooling control are performed. In the temperature area where both heating and cooling output overlap, both of the output negate each other, thus the control gain becomes moderate. Consequently, the change amount in the temperature process value (PV) for the output becomes small, improving control stability.

Ex. When buffer memory values are set as following:

- CH□ Input range (Un\G32, Un\G64, Un\G96, Un\G128): 38 (temperature measurement range: -200.0°C to 400.0°C)
- CH□ Set value (SV) setting (Un\G34, Un\G66, Un\G98, Un\G130): 200 (200.0°C)
- CH□ Overlapping/dead band setting (Un\G723, Un\G739, Un\G755, Un\G771): -25 (-2.5%)

185.0°C to 200.0°C is the overlapping area.

$(\text{Full scale}) \times (\text{Overlap setting}) = (400.0^\circ\text{C} - (-200.0^\circ\text{C})) \times -0.025 = -15.0^\circ\text{C}$

The temperature where cooling operation starts = $(\text{Set value (SV)}) - 15.0^\circ\text{C} = 185.0^\circ\text{C}$

As shown below, shifting the temperature where cooling operation starts to the lower temperature side of the set value (SV) produces an overlapping area. (The following is an example of when the module is in P control.)

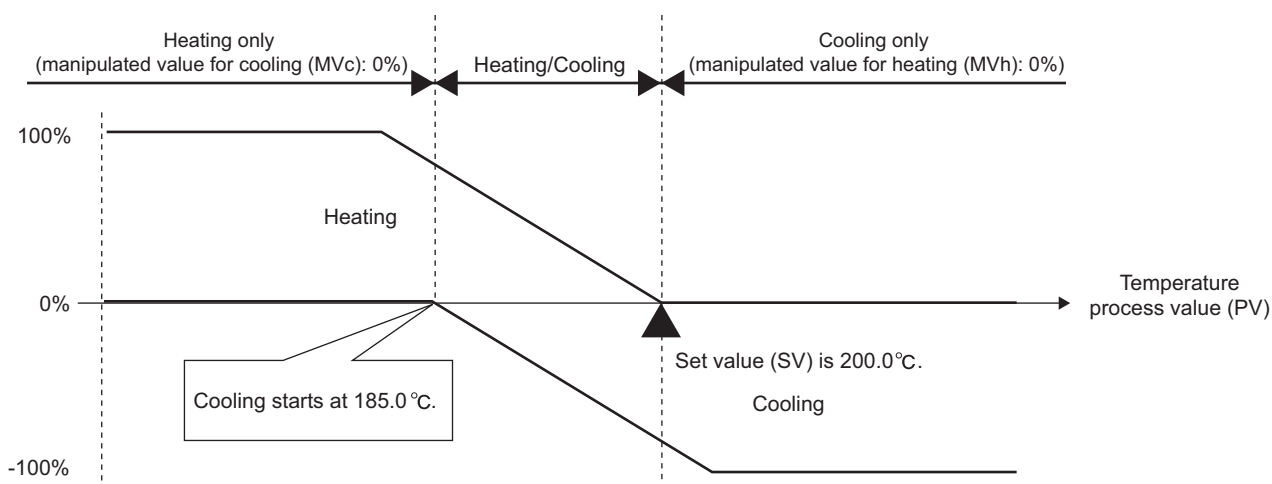

(2) Dead band

Dead band refers to the temperature area where neither heating control output nor cooling control output is performed. When the temperature process value (PV) is stable within this area, output is not performed for the slight change in the temperature, resulting in energy saving.

Ex. When buffer memory values are set as following:

- CH□ Input range (Un\G32, Un\G64, Un\G96, Un\G128): 38 (temperature measurement range: -200.0°C to 400.0°C)
- CH□ Set value (SV) setting (Un\G34, Un\G66, Un\G98, Un\G130): 2000 (200.0°C)
- CH□ Overlapping/dead band setting (Un\G723, Un\G739, Un\G755, Un\G771): 25 (2.5%)
200.0°C to 215.0°C is the area for dead band.

$$(\text{Full scale}) \times (\text{Overlap setting}) = (400.0^\circ\text{C} - (-200.0^\circ\text{C})) \times 0.025 = 15.0^\circ\text{C}$$

$$\text{The temperature where cooling operation starts} = (\text{Set value (SV)}) + 15.0^\circ\text{C} = 215.0^\circ\text{C}$$

As shown below, shifting the temperature where cooling operation starts to the higher temperature side of the set value (SV) produces a dead band area. (The following is an example of when the module is in P control.)

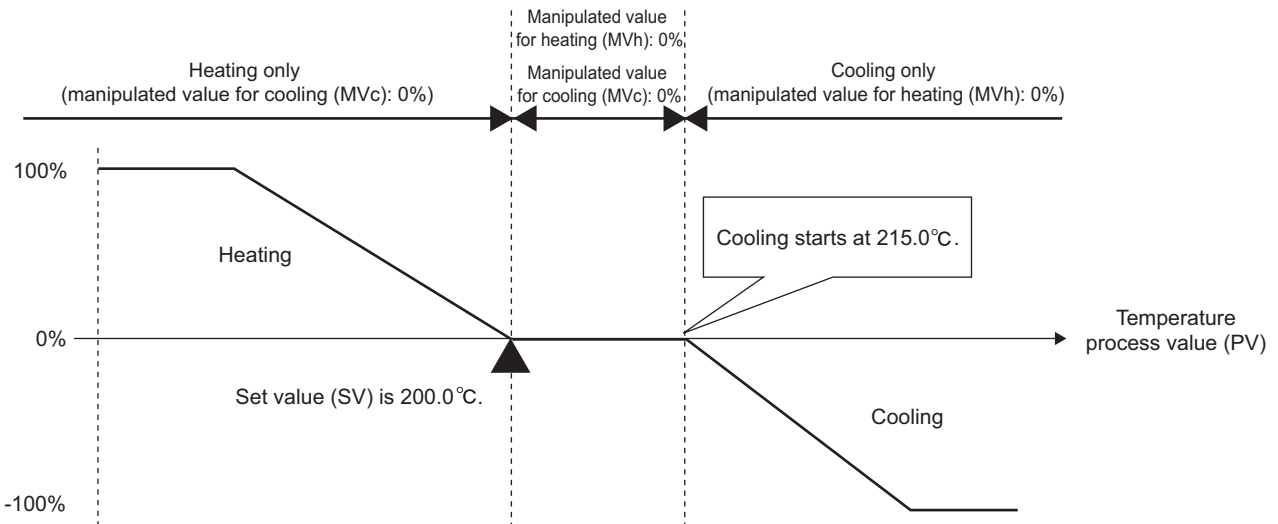

(3) Dead band setting in two-position control (three-position control)

Set the dead band in two-position control.

Three-position control can be achieved by setting a dead band area in addition to areas for the manipulated value for heating (MVh) 100% and the manipulated value for cooling (MVc) 100%.

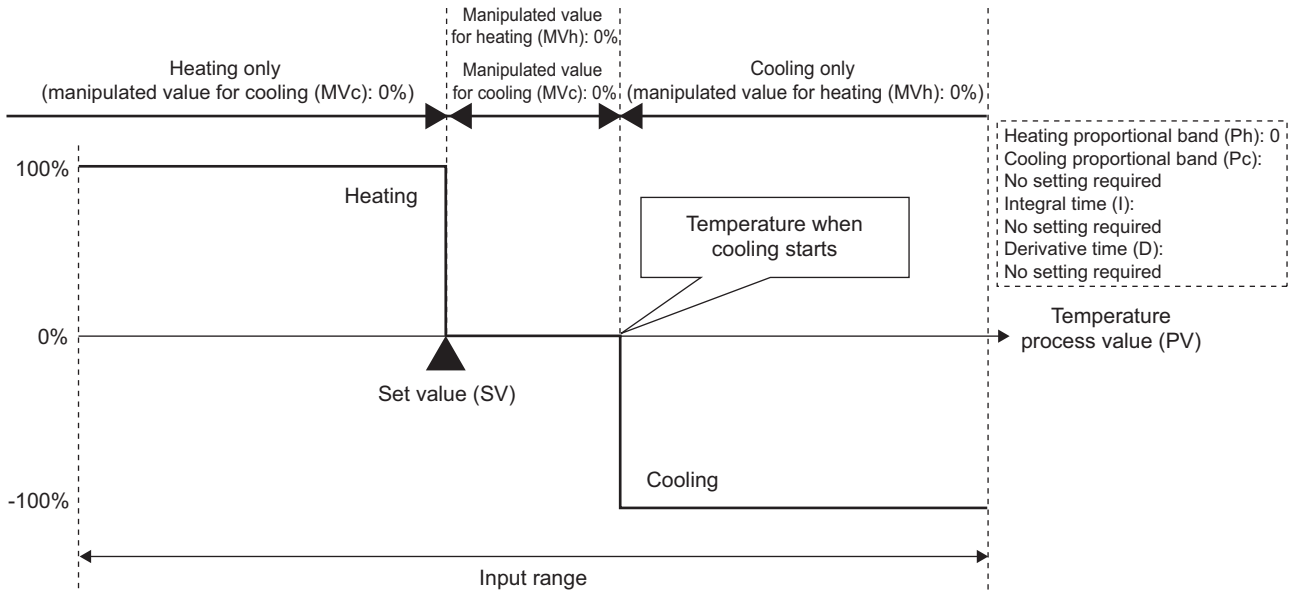

(4) Setting method

Set the function under "Overlap/dead band setting".

Project window ⇨ [Intelligent Function Module] ⇨ Module name ⇨ [Parameter]

Item	CH1
Overlap/dead band setting	5.0 %
Process value (PV) scaling function	Disable

8.2.23 Temperature conversion function (using unused channels)

Heating-cooling

In heating-cooling control (normal mode) and mix control (normal mode), only temperature measurement can be performed by using unused temperature input terminals. When this function is used, temperature control and alert judgment are not performed.

(1) Temperature input terminals that can be used

Temperature input terminals that can be used for this function differ depending on the control mode. Use the terminals indicating MT2□ (Monitor CH2), MT3□ (Monitor CH3), and MT4□ (Monitor CH4) in the following table.

Terminal No.	Terminal symbol			
	L60TCTT4/L60TCTT4BW*1		L60TCRT4/L60TCRT4BW*1	
	Heating-cooling control (normal mode)	Mix control (normal mode)	Heating-cooling control (normal mode)	Mix control (normal mode)
1	L1H	L1H	L1H	L1H
2	L1C	L1C	L1C	L1C
3	L2H	L3	L2H	L3
4	L2C	L4	L2C	L4
5	COM-	COM-	COM-	COM-
6	Unused	Unused	Unused	Unused
7	CH1+	CH1+	CH1 A	CH1 A
8	CH2+	MT2+	CH2 A	MT2 A
9	CH1-	CH1-	CH1 B	CH1 B
10	CH2-	MT2-	CH2 B	MT2 B
11	Unused	Unused	CH1 b	CH1 b
12	CJ	CJ	CH2 b	MT2 b
13	Unused	Unused	MT3A	CH3 A
14	CJ	CJ	MT4A	CH4 A
15	MT3+	CH3+	MT3B	CH3 B
16	MT4+	CH4+	MT4B	CH4 B
17	MT3-	CH3-	MT3b	CH3 b
18	MT4-	CH4-	MT4b	CH4 b

*1 For the L60TCTT4BW and L60TCRT4BW, the terminals in the table above are those on a terminal block for I/O.

(2) Current consumption of when this function is used

Current consumption differs depending on whether the temperature conversion function is used or not.

(3) Buffer memory areas that can be used with this function

The following table lists the buffer memory areas that can be used with this function (the terminals used correspond to the buffer memory areas in the table).

Buffer memory area name	Buffer memory			Reference
	MT2 (Monitor CH2)	MT3 (Monitor CH3)	MT4 (Monitor CH4)	
Error code	Un\G0			Page 334, Appendix 2 (1)
CH□ Decimal point position	Un\G2	Un\G3	Un\G4	Page 334, Appendix 2 (2)
CH□ Alert definition	Un\G6	Un\G7	Un\G8	Page 336, Appendix 2 (3)
CH□ Temperature process value (PV)	Un\G10	Un\G11	Un\G12	Page 338, Appendix 2 (4)
Cold junction temperature process value	Un\G29			Page 342, Appendix 2 (9)
CH□ Input range	Un\G64	Un\G96	Un\G128	Page 345, Appendix 2 (12)
CH□ Sensor correction value setting	Un\G77	Un\G109	Un\G141	Page 363, Appendix 2 (21)
CH□ Primary delay digital filter setting	Un\G80	Un\G112	Un\G144	Page 365, Appendix 2 (24)
Cold junction temperature compensation selection	Un\G182			Page 384, Appendix 2 (49)
Control switching monitor	Un\G183			Page 385, Appendix 2 (50)
CH□ 2-point sensor compensation offset value (measured value)	Un\G576	Un\G608	Un\G640	Page 394, Appendix 2 (63)
CH□ 2-point sensor compensation offset value (compensation value)	Un\G577	Un\G609	Un\G641	Page 394, Appendix 2 (64)
CH□ 2-point sensor compensation gain value (measured value)	Un\G578	Un\G610	Un\G642	Page 395, Appendix 2 (65)
CH□ 2-point sensor compensation gain value (compensation value)	Un\G579	Un\G611	Un\G643	Page 395, Appendix 2 (66)
CH□ 2-point sensor compensation offset latch request	Un\G580	Un\G612	Un\G644	Page 396, Appendix 2 (67)
CH□ 2-point sensor compensation offset latch completion	Un\G581	Un\G613	Un\G645	Page 396, Appendix 2 (68)
CH□ 2-point sensor compensation gain latch request	Un\G582	Un\G614	Un\G646	Page 397, Appendix 2 (69)
CH□ 2-point sensor compensation gain latch completion	Un\G583	Un\G615	Un\G647	Page 397, Appendix 2 (70)
Sensor compensation function selection	Un\G785			Page 413, Appendix 2 (91)
Temperature conversion completion flag	Un\G786			Page 413, Appendix 2 (92)
CH□ Temperature conversion setting	Un\G695	Un\G696	Un\G697	Page 403, Appendix 2 (76)

(4) Setting method

Set whether using this function under "Temperature conversion setting".

 Project window ⇨ [Intelligent Function Module] ⇨ Module name ⇨ [Parameter]

Item	CH1	CH2
Temperature conversion		0:Not Used
Cooling method setting	0:Air Cooled	0:Not Used
Cooling upper limit output limiter	100.0 %	1:Use

Point

When heating-cooling control (expanded mode) or mix control (expanded mode) is selected, the setting in CH□ Temperature conversion setting (Un\G695 to Un\G697) is ignored.

8.2.24 Heater disconnection detection function

Standard Heating-cooling

When transistor output is on, whether a heater is disconnected or not can be checked based on a reference heater current value (load current value detected by a current sensor (CT)) using this function. A reference heater current value and heater disconnection alert current value are compared. When the reference heater current value becomes lower than the heater disconnection alert current value, the heater is regarded as disconnected.

Heater disconnection is detected every 500ms. When transistor output is on for 500ms or less, heater disconnection is not detected. (CH□ Heater disconnection detection (b12 of Un\G5 to Un\G8) remains 0 (OFF).) (Page 336, Appendix 2 (3))

The following is the timing output as an alert.

- 500ms × Setting value in Heater disconnection/output off-time current error detection delay count (Un\G166)

If a heater is disconnected longer than the time described above, Alarm code: 04□AH is stored in Error code (Un\G0).

(Page 318, Section 11.7)

(1) Modules where this function can be used

- L60TCTT4BW
- L60TCRT4BW

(2) Setting method

Set the function on "Parameter". Follow the instructions below.

Project window ⇨ [Intelligent Function Module] ⇨ Module name ⇨ [Parameter]

Item	CH1	CH2
CT1 CT selection	0:CTL-12-S36-8(0.0 to 100.0A)	
CT2 CT selection	0:CTL-12-S36-8(0.0 to 100.0A)	
CT3 CT selection	1:CTL-6-P(-H)(0.00 to 20.00A)	
CT4 CT selection	2:Use CT Ratio Setting (0.0 to 100.0A)	
CT5 CT selection	0:CTL-12-S36-8(0.0 to 100.0A)	
CT6 CT selection	0:CTL-12-S36-8(0.0 to 100.0A)	
CT7 CT selection	0:CTL-12-S36-8(0.0 to 100.0A)	
CT8 CT selection	0:CTL-12-S36-8(0.0 to 100.0A)	
CT1 Reference heater current		



CT1 CT Ratio setting	800
CT2 CT Ratio setting	800
CT3 CT Ratio setting	800
CT4 CT Ratio setting	800
CT5 CT Ratio setting	800
CT6 CT Ratio setting	800
CT7 CT Ratio setting	800
CT8 CT Ratio setting	800



Item	CH1	CH2
CT setting	External current sensors	
CT1 CT input channel assignment setting	1:CH1	
CT2 CT input channel assignment setting	0:Unused	
CT3 CT input channel assignment setting	1:CH1	
CT4 CT input channel assignment setting	2:CH2	
	3:CH3	
	4:CH4	
	0:Unused	



(To the next page)

1. Set the current sensor (CT) to be used under "CT□ CT selection".

2. When using a current sensor (CT) other than CTL-12-S36-8 and CTL-6-P(-H) manufactured by U.R.D.Co., LTD., set "CT□ CT Ratio setting".

3. Set the CT input assigned to each channel under "CT□ CT input channel assignment setting".

(From the previous page)



Address	F	E	D	C	B	A	9	8	7	6	5	4	3	2	1	0		
256	0	0	0	0	0	0	0	0	0	0	0	1	0	1	0	1	0	42
257	0	0	0	0	0	0	0	0	0	0	0	0	0	0	0	0	0	0
258	0	0	0	0	0	0	0	0	0	0	0	0	0	0	0	0	0	0
259	0	0	0	0	0	0	0	0	0	0	0	0	0	0	0	0	0	0
260	0	0	0	0	0	0	0	0	0	0	0	0	0	0	0	0	0	0
261	0	0	0	0	0	0	0	0	0	0	0	0	0	0	0	0	0	0
262	0	0	0	0	0	0	0	0	0	0	0	0	0	0	0	0	0	0
263	0	0	0	0	0	0	0	0	0	0	0	0	0	0	0	0	0	0
264	0	0	0	0	0	0	0	0	0	0	0	0	0	0	0	0	0	1



Item	CH1
CT1 Reference heater current value	4.2 A
CT2 Reference heater current value	0.0 A
CT3 Reference heater current value	0.0 A
CT4 Reference heater current value	0.0 A
CT5 Reference heater current value	0.0 A
CT6 Reference heater current value	0.0 A
CT7 Reference heater current value	0.0 A
CT8 Reference heater current value	0.0 A



Item	CH1
Heater disconnection alert	90 %
Heater disconnection/output off-time current error detection	3 Times



Item	CH1
CT monitor method switching	0:ON/OFF Current
CT setting	0:ON/OFF Current
CT1 CT input channel assignment setting	1:ON Current



Item	CH1
Heater disconnection/output off-time current error detection delay count	3 Times
Heater disconnection	n:OFF



End

*1 For details on the output off-time current error detection function, refer to Page 220, Section 8.2.25.

Point

- The standard setting value for CH Heater disconnection alert setting (Un\G58, Un\G90, Un\G122, Un\G154) is 80%. However, the current value may significantly change depending on the characteristics of a heater or how the heater is used. Check that there is no problem in the actual system.
- A write data error (error code: □□□4_H) occurs if the current value to be used as a judgment value to detect heater disconnection (reference heater current value × CH Heater disconnection alert setting (%)) is within 0.1A under one of the following situations:
 - CT CT selection (Un\G272 to Un\G279) is set to When CTL-12-S36-8 (0.0A to 100.0A) is used (0).
 - CT CT ratio selection (Un\G272 to Un\G279) is set to When CT ratio setting is used (0.0A to 100.0A) (2).
 In addition, when CTL-6-P(-H) used (0.00A to 20.00A) (1) has been set and the current value to be used as a judgment value to detect heater disconnection (reference heater current value × CH Heater disconnection alert setting (%)) is within 0.01A, Write data error (error code:□□□4_H) occurs.

4. Monitor CT Heater current process value (Un\G256 to Un\G263) and check the current value of when the heater is on. (Page 390, Appendix 2 (58))
5. Set the value monitored in CT Heater current process value (Un\G256 to Un\G263) under "CT Reference heater current value".
6. Set the judgment value to perform the heater disconnection detection and output off-time current error detection*1 at the rate of the reference heater current value (%) under "Heater disconnection alert setting".
7. To monitor only the current value of when the heater is on, set "1: ON Current" under "CT monitor method switching". To monitor the current values of when the heater is on and off, set "0: ON/OFF Current".
8. Set how many times heater disconnection is detected successively to regard the heater as disconnected under "Heater disconnection/output off-time current error detection delay count".

(3) Heater disconnection correction function

When heater voltage is dropped, heater current is reduced. The L60TCTT4BW and L60TCRT4BW detect heater disconnection by measuring heater current; therefore, an accidental alert may occur due to a voltage change caused by a reduced heater voltage.

The heater disconnection correction function offsets the amount of heater current reduced (heater disconnection correction), preventing disconnection from being detected.

(a) Calculation formula for heater disconnection correction

Calculate (CH□ Heater current) - (reference heater current value). The largest positive value is the correction value. When there is no positive value, the value with the smallest gap is the correction value. The heater current for each channel is corrected using a correction value. When the corrected value is larger than the heater disconnection alert setting value, heater disconnection is found.

Ex. When CH□ Heater disconnection alert setting (Un\G58, Un\G90, Un\G122, Un\G154) is 80% and the differences between CH□ Heater current and the reference heater current value are the following values:

- CH1: -2%
- CH2: 5%
- CH3: -1%
- CH4: -17%

The following table lists the result.

Channel	CH□ Heater disconnection alert setting (Un\G58, Un\G90, Un\G122, Un\G154)	Difference between CH□ Heater current and reference heater current value	Correction value	Difference between CH□ Heater current and reference heater current value after correction	Disconnection detected
CH1	80 (%)	-2%	5%	-7% (= -2% - 5%)	Not detected
CH2		5%		0% (= 5% - 5%)	Not detected
CH3		-1%		-6% (= -1% - 5%)	Not detected
CH4		-17%		-22% (= -17% - 5%)	Detected

In the table above, the correction value is 5%. Heater disconnection is detected based on the differences of -7% for CH1, 0% for CH2, -6% for CH3, and -22% for CH4. When Heater disconnection alert setting is set to 80%, disconnection is detected only for CH4.

Ex. When CH□ Heater disconnection alert setting (Un\G58, Un\G90, Un\G122, Un\G154) is 80% and the differences between CH□ Heater current and the reference heater current value are the following values:

- CH1: -16%
- CH2: -17%
- CH3: -22%
- CH4: -19%

The following table lists the result.

Channel	CH□ Heater disconnection alert setting (Un\G58, Un\G90, Un\G122, Un\G154)	Difference between CH□ Heater current and reference heater current value	Correction value	Difference between CH□ Heater current and reference heater current value after correction	Disconnection detected
CH1	80 (%)	-16%	-16%	0% (= -16% - (-16%))	Not detected
CH2		-17%		-1% (= -17% - (-16%))	Not detected
CH3		-22%		-6% (= -22% - (-16%))	Not detected
CH4		-19%		-3% (= -19% - (-16%))	Not detected

In the table above, the correction value is -16%. Heater disconnection is detected based on the differences of 0% for CH1, -1% for CH2, -6% for CH3, and -3% for CH4. When Heater disconnection alert setting is set to 80%, none of the channels are regarded as disconnected.

(b) Restrictions

- When only one channel is used, the heater disconnection correction function does not work. To use this function, two channels or more need to be used.
- When several channels are used with a heater on for one channel and heaters off for other channels, the heater disconnection correction function does not function. Therefore, disconnection may be detected even if there is no disconnection.
- The heater disconnection alert correction value is 20% at maximum. When Heater disconnection alert setting is set to 80% as shown in the two examples on  Page 217, Section 8.2.24 (3) (a), the conditions for disconnection detection are satisfied even if correction is performed by 20% with a voltage drop by 40% or more. Consequently, disconnection is detected.

(c) Setting method

Set "Heater disconnection compensation function selection" to "1: ON".

 Project window ⇨ [Intelligent Function Module] ⇨ Module name ⇨ [Parameter]

Item	CH1
Heater disconnection compensation function	0:OFF
Process alarm alert output enable/disable setting	0:OFF
	1:ON

(4) To clear the disconnection detection status

Disconnection detection is disabled by restoring the disconnection status and turning CH□ Heater disconnection detection (b12 of Un\G5 to Un\G8) from 1 (ON) to 0 (OFF). (☞ Page 336, Appendix 2 (3))

Under the following setting, however, CH□ Heater disconnection detection (b12 of Un\G5 to Un\G8) does not change from 1 (ON) to 0 (OFF) unless a heater turns on.

- CT monitor method switching (Un\G176) is set to ON Current (1).

The timing when a heater turns on differs depending on the setting for the following buffer memory areas.

Buffer memory area name	Buffer memory address				Reference
	CH1	CH2	CH3	CH4	
CH□ Control output cycle setting	Un\G47	Un\G79	Un\G111	Un\G143	Page 364, Appendix 2 (23)
CH□ Heating control output cycle setting	Un\G47	Un\G79	Un\G111	Un\G143	
CH□ Cooling control output cycle setting	Un\G722	Un\G738	Un\G754	Un\G770	

8.2.25 Output off-time current error detection function

Standard Heating-cooling

Transistor output errors can be detected using this function. The current sensor (CT) for heater disconnection detection is used to check for errors of when transistor output is off.

A heater current measurement value and heater disconnection alert current value are compared. If the heater current measurement value is larger than the heater disconnection alert current value, an output off-time current error occurs. Output off-time current errors are detected every 500ms. When transistor output is off for 500ms or less, output off-time current errors are not detected. (CH□ Output off-time current error (b14 of Un\G5 to Un\G8) stays 0 (OFF).)

( Page 336, Appendix 2 (3))

The following is the timing output as an alert.

- $500\text{ms} \times \text{Setting value for Heater disconnection/output off-time current error detection delay count}$
(Un\G166)

If an output off-time current error status lasts longer than the time described above, Alarm code (05□A_H) is stored in Error code (Un\G0). ( Page 318, Section 11.7)

(1) Modules where this function can be used

- L60TCTT4BW
- L60TCRT4BW

(2) Setting method

The setting method is the same as that for the heater disconnection detection function. ( Page 215, Section 8.2.24)

8.3 Common Functions

This section explains the common functions between the temperature input mode and temperature control mode.

8.3.1 Temperature process value (PV) scaling function

Common

The temperature process value (PV) is scaled up or down to the value in a set range, and can be stored into the buffer memory using this function. For example, the range of -100°C to 100°C can be scaled into the value range of 0 to 4000.

(1) Monitoring the scaling value

The temperature process value (PV) after scaling processing is stored into the following buffer memory area.

- CH□ Process value (PV) scaling value (Un\G728, Un\G744, Un\G760, Un\G776) (☞ Page 406, Appendix 2 (82))

The calculation method of a scaling value is as follows:

$$\text{CH}\square \text{ Process value (PV) scaling value (Un\G728, Un\G744, Un\G760, Un\G776)} = \frac{(\text{SH} - \text{SL}) \times (\text{Px} - \text{PMin})}{\text{PMax} - \text{PMin}} + \text{SL}$$

Px: CH□ Temperature process value (PV) (Un\G9, Un\G10, Un\G11, Un\G12)

PMax: A maximum value of CH□ Input range (Un\G32, Un\G64, Un\G96, Un\G128)

PMin: A minimum value of CH□ Input range (Un\G32, Un\G64, Un\G96, Un\G128)

SH: CH□ A maximum scaling value of process value (PV) (Un\G727, Un\G743, Un\G759, Un\G775)

SL: CH□ A minimum scaling value of process value (PV) (Un\G726, Un\G742, Un\G758, Un\G774)

(a) Calculation example

A calculation example to scale the temperature process value (PV) into percentage is shown below.

Set the following buffer memory areas as below.

- CH□ Input range (Un\G32, Un\G64, Un\G96, Un\G128): 38 (Temperature measurement range: -200.0°C to 400.0°C)
- CH□ Process value (PV) scaling lower limit value (Un\G726, Un\G742, Un\G758, Un\G774): 0
- CH□ Process value (PV) scaling upper limit value (Un\G727, Un\G743, Un\G759, Un\G775): 100

Suppose that 3600 (360.0°C) is stored in CH□ Temperature process value (PV) (Un\G9 to Un\G12).

The scaling value can be calculated as follows:

$$\begin{aligned} \text{CH}\square \text{ Process value (PV) scaling value (Un\G728, Un\G744, Un\G760, Un\G776)} &= \frac{(100 - 0) \times (3600 - (-2000))}{4000 - (-2000)} + 0 \\ &= 93.333 \dots \\ &= 93 \text{ (All decimal places are rounded off to an integer.)} \end{aligned}$$

(2) Setting method

Set the function on "Parameter". Follow the instructions below.

 Project window ⇨ [Intelligent Function Module] ⇨ Module name ⇨ [Parameter]

Item	CH1
Process value (PV) scaling function enable/disable setting	0:Disable
Process value (PV) scaling lower limit value	0:Disable 1:Enable







Item	CH1
Process value (PV) scaling lower limit value	0
Process value (PV) scaling upper limit value	100



End

1. Enable or disable the temperature process value (PV) scaling function under "Process value (PV) scaling function enable/disable setting".
2. Set a scaling upper limit value and lower limit value under "Process value (PV) scaling lower limit value" and "Process value (PV) scaling upper limit value".

Point

- An error does not occur even though the areas above are set as follows: Lower limit value \geq Upper limit value. The scaling is processed according to the calculation method described on  Page 221, Section 8.3.1 (1).
- If a value outside the temperature measurement range is measured, the value set as a upper limit or lower limit is stored into the following buffer memory area.
 - CH□ Process value (PV) scaling value (Un\G728, Un\G744, Un\G760, Un\G776) ( Page 406, Appendix 2 (82))
- Values on other analog modules in the system (such as an A/D converter module) can be scaled to a set range. For that processing, set a 200s value in CH□ Input range (Un\G32, Un\G64, Un\G96, Un\G128). ( Page 345, Appendix 2 (12))
To input a value from other analog modules (such as an A/D converter module), store the input value into the following buffer memory area.
 - CH□ Temperature process value (PV) for input with another analog module (Un\G689 to Un\G692) ( Page 402, Appendix 2 (74))To scale an input value from other analog modules (such as an A/D converter module), apply the buffer memory area above to the description in this section.

8.3.2 Sensor compensation function

Common

When a difference occurs between the temperature process value (PV) and the actual temperature due to reasons such as a measuring condition, the difference can be corrected using this function. The following two types are available.

- 1-point sensor compensation (standard) function (☞ Page 223, Section 8.3.2 (1))
- 2-point sensor compensation function (☞ Page 227, Section 8.3.2 (2))

(1) 1-point sensor compensation (standard)

The set input range in proportion to the full scale is corrected as a difference correction value using this function.

Ex. When buffer memory values are set as following:

- CH□ Input range (Un\G32, Un\G64, Un\G96, Un\G128): 21 (temperature measurement range: -200.0°C to 200.0°C)
- CH□ Sensor correction value setting (Un\G45, Un\G77, Un\G109, Un\G141): 50 (0.500%)

The difference between the temperature process value (PV) and the actual temperature is 2°C that can be corrected.

$$\begin{aligned} \text{Temperature process value (PV) - actual temperature} &= \frac{\text{Full scale} \times \text{Sensor correction value setting}}{100} \\ &= \frac{400 \times 0.500}{100} = 2 \text{ (}^\circ\text{C)} \end{aligned}$$

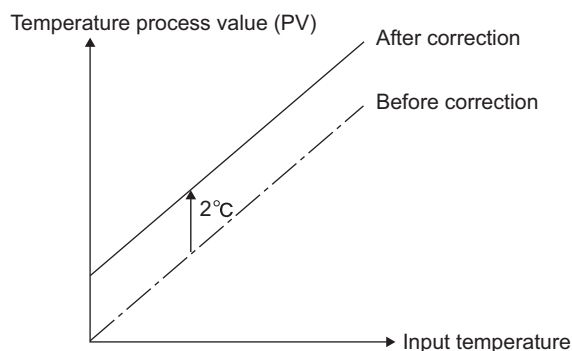

(a) How to execute 1-point sensor compensation (standard) (when using GX Works2)

Set the setting on the "Sensor Compensation Function" window.

 [Tool] ⇨ [Intelligent Function Module Tool] ⇨ [Temperature Control Module] ⇨ [Sensor Compensation Function]

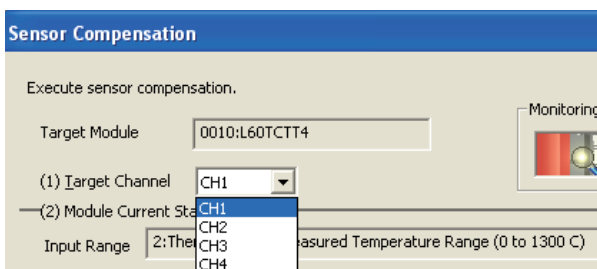
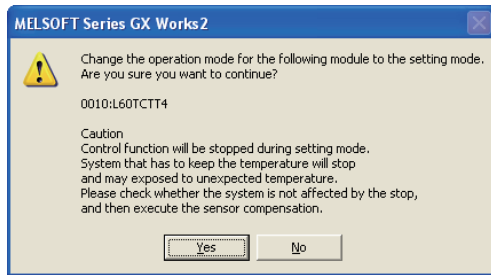
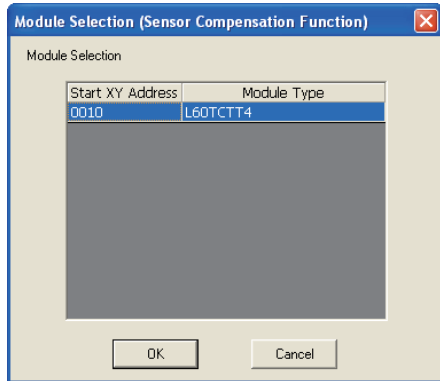

(To the next page)

1. Select the module where sensor correction is executed and click .

2. Click .

3. Click .

4. Select the channel where sensor correction is executed under "Target Channel".

(From the previous page)

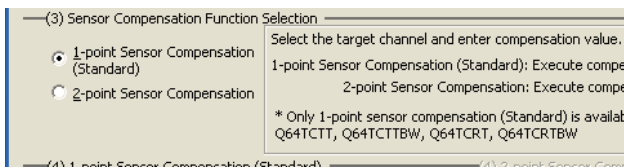

5. Select "1-point Sensor Compensation (Standard)" under "Sensor Compensation Function Selection".

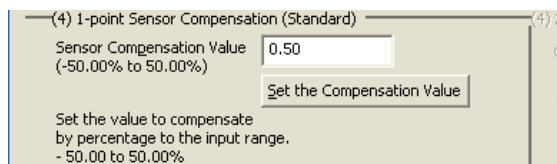

6. Set "Sensor Compensation Value" and click .

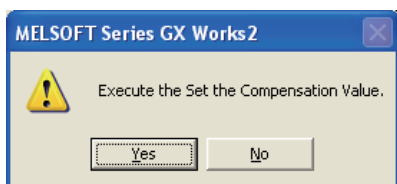

7. Click .

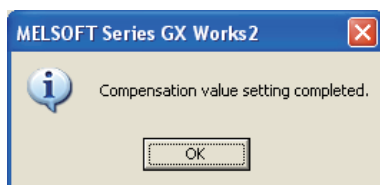

8. Click .

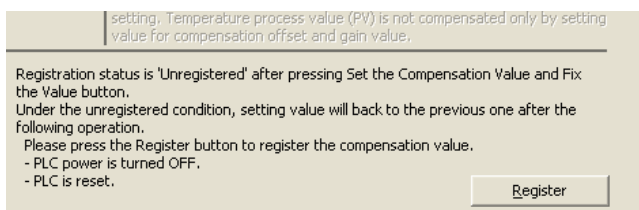

9. To back up the correction value in the non-volatile memory, click .

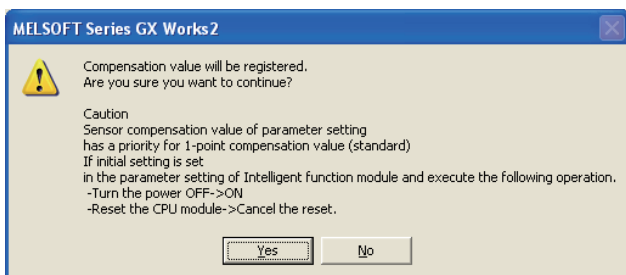

10. Click .

(To the next page)

(From the previous page)

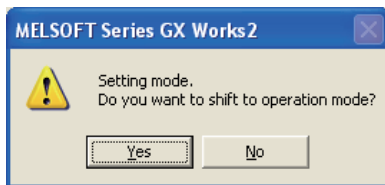
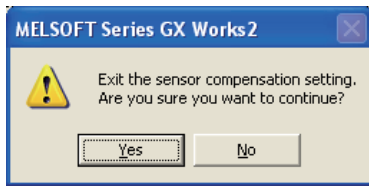
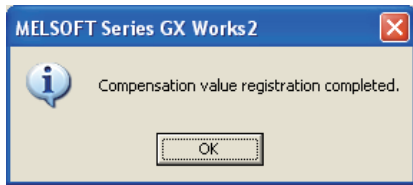

End

11. Click .

12. Click .

13. Click .

14. Click .

Remark

By executing 1-point sensor compensation in "Sensor Compensation", the action after the correction can be checked temporarily. To use the compensation value set in "Sensor Compensation" thereafter, set it on "Sensor correction value setting" in "Parameter". Doing so holds the compensation value as a parameter. For the setting in "Parameter", refer to the following.

☞ Page 110, Section 7.3

(b) How to execute 1-point sensor compensation (standard) (when using the program)

Follow the instructions below.

1. Set 1-point sensor compensation (standard) (0 μ) in Sensor compensation function selection (Un\G785). (☞ Page 413, Appendix 2 (91))
2. Set the correction value in CH□ Sensor correction value setting (Un\G45, Un\G77, Un\G109, Un\G141). (☞ Page 363, Appendix 2 (21))

(2) 2-point sensor compensation function

With this function, the difference between the temperature process value (PV) and the actual temperature between the two points selected in advance (a corrected offset value and a corrected gain value) is stored. Based on this gradient, the difference between a sensor and the actual temperature is corrected.

2-point sensor compensation is performed in the setting mode (Setting/operation mode status (Xn1): off). In addition, set CH□ Stop mode setting (Un\G33, Un\G65, Un\G97, Un\G129) to Monitor (1).

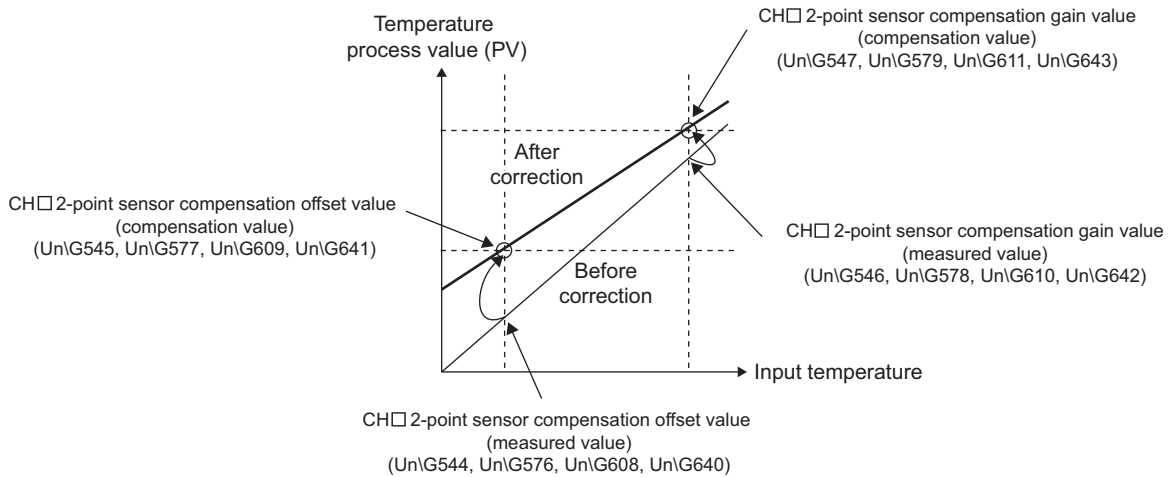

(a) How to execute 2-point sensor compensation (when using GX Works2)

Set this function on the "Sensor Compensation Function" window.

 [Tool] ⇒ [Intelligent Function Module & Tool] ⇒ [Temperature Control Module] ⇒ [Sensor Compensation Function]

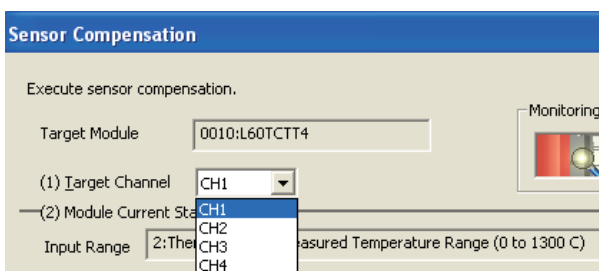
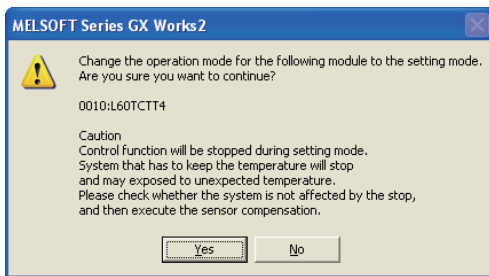
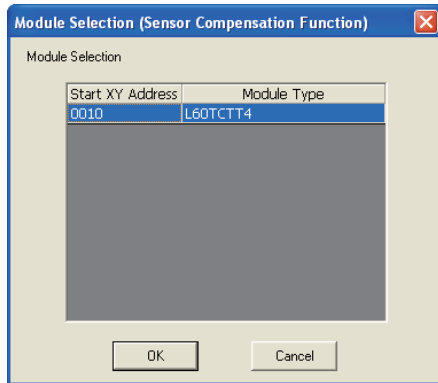

(To the next page)

1. Select the module where sensor correction is executed and click .

2. Click .

3. Click .

4. Select the channel where sensor correction is executed under "Target Channel".

(From the previous page)

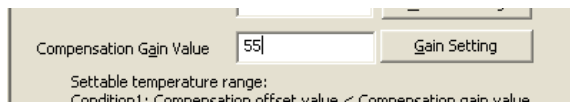
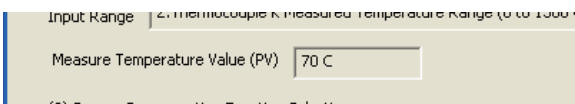
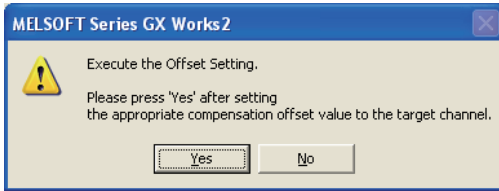
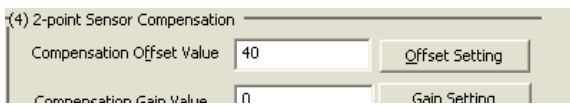
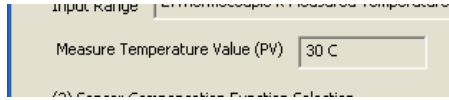
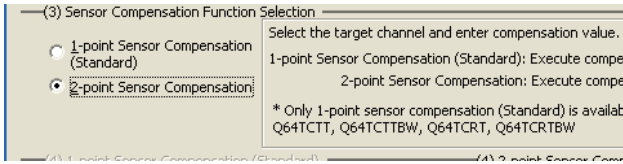

(To the next page)

5. Select "2-point Sensor Compensation" under "Sensor Compensation Function Selection".

6. Monitor "Temperature process value (PV)" and enter the corrected offset value.*1

7. Set the Temperature process value (PV) to be input under "Compensation Offset Value". Then click



8. Click

9. Click

10. Monitor "Temperature process value (PV)" and enter the corrected gain value.*1

11. Set the temperature process value (PV) to be input under "Compensation Gain Value". Then click

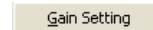

(From the previous page)

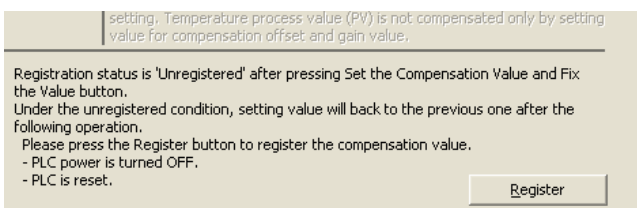
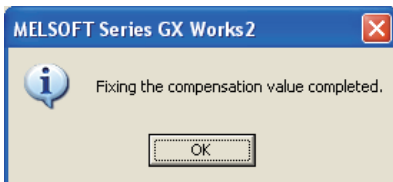
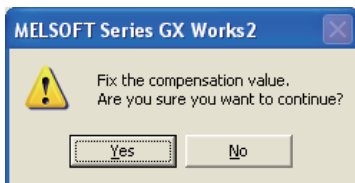
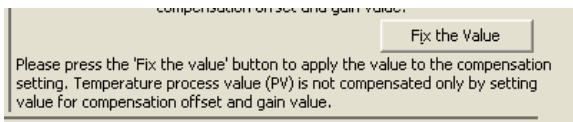
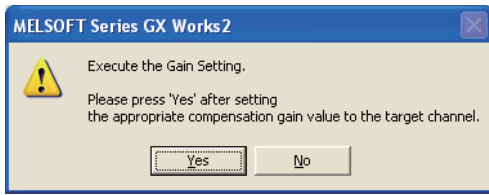

(To the next page)

12. Click .

13. Click .

14. Click .

15. Click .

16. Click .

17. To back up the correction value in the non-volatile memory, click .

(From the previous page)

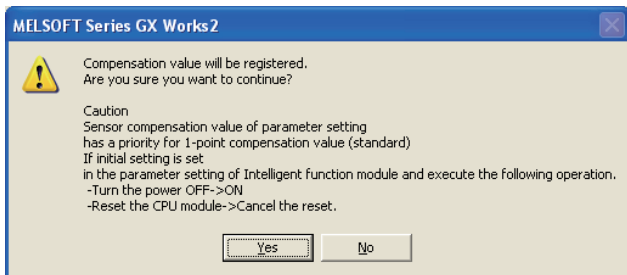

18. Click .

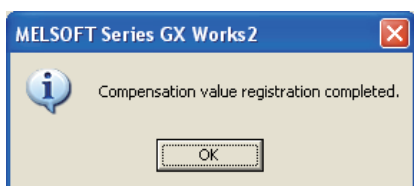

19. Click .

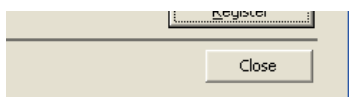

20. Click .

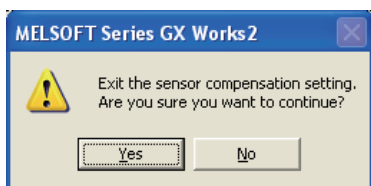

21. Click .

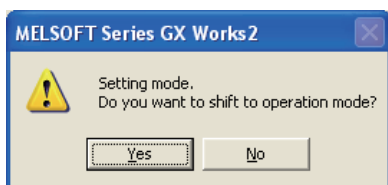

22. To shift from the setting mode to the operation mode, click .



End

*1 Enter the value using devices such as a thermocouple, platinum resistance thermometer, and standard DC voltage generator, or based on a general resistance value.

(b) How to execute 2-point sensor compensation (when using the program)

Follow the instructions below.

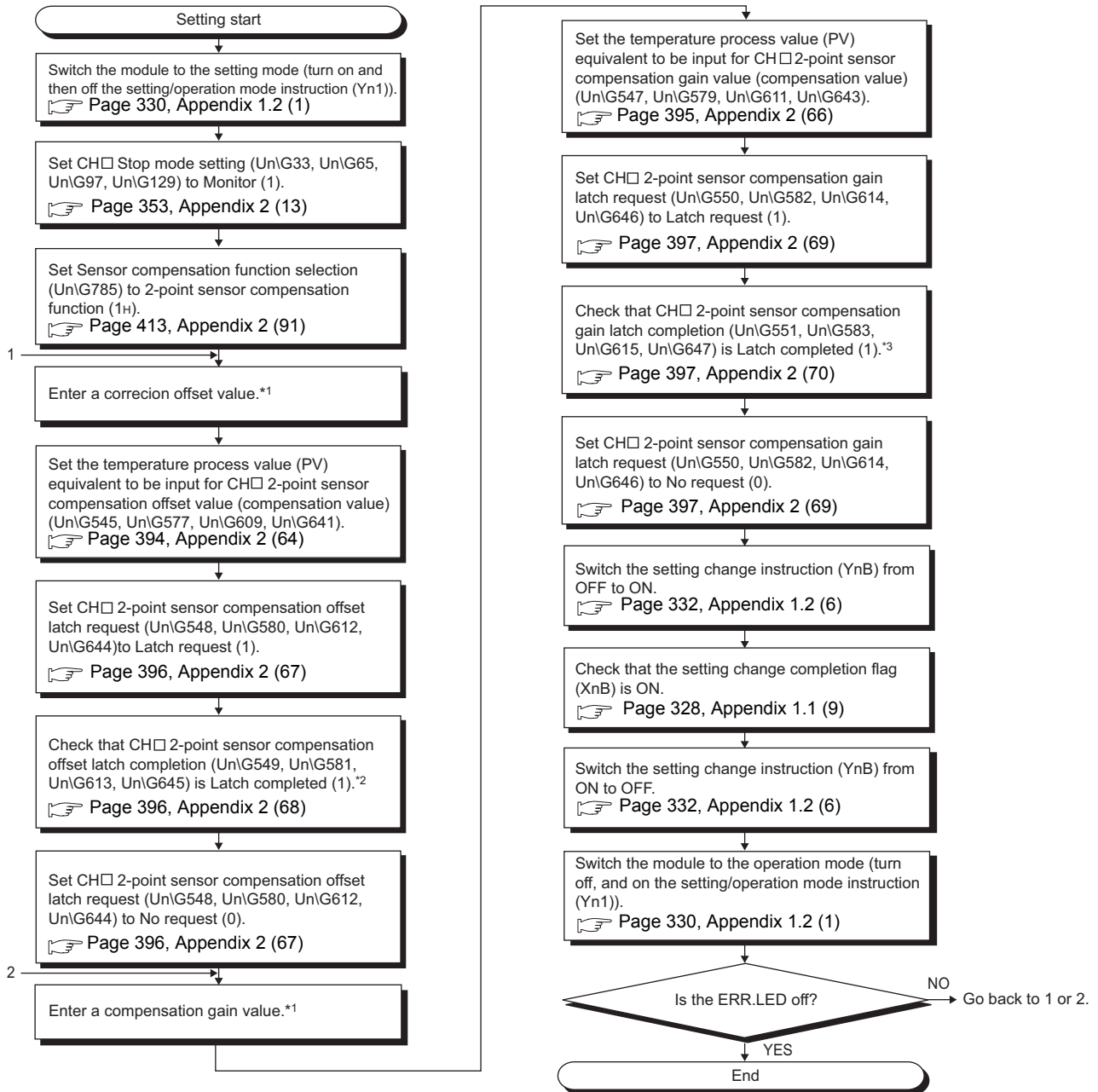

*1 Enter the value using devices such as a thermocouple, platinum resistance thermometer, and standard DC voltage generator, or based on a general resistance value.

*2 When the latch is completed, the temperature process value (PV) is stored in CH□ 2-point sensor compensation offset value (measured value) (Un\G544, Un\G576, Un\G608, Un\G640). (☞ Page 394, Appendix 2 (63))

*3 When the latch is completed, the temperature process value (PV) is stored in CH□ 2-point sensor compensation gain value (measured value) (Un\G546, Un\G578, Un\G610, Un\G642). (☞ Page 395, Appendix 2 (65))

Point 

- If a write data error (error code: □□□7_H) occurs during 2-point sensor compensation, correctly configure the setting for 2-point sensor compensation again. (The value set for 2-point sensor compensation of when an error occurred is not written in the L60TC4.)
- To use the value set for 2-point sensor compensation even after the power is turned off and on or the CPU module is reset and the reset is cancelled, back up the value with the following method.
 - Turn off and on Setting value backup instruction (Yn8). ( Page 332, Appendix 1.2 (3))

8.3.3 Auto configuration at input range change function

Common

When an input range is changed, using this function automatically changes related buffer memory data to prevent an error outside the setting range. Set the function on the "Switch Setting" window.

For details on the setting method, refer to the following.

☞ Page 108, Section 7.2

The following is the setting timing.

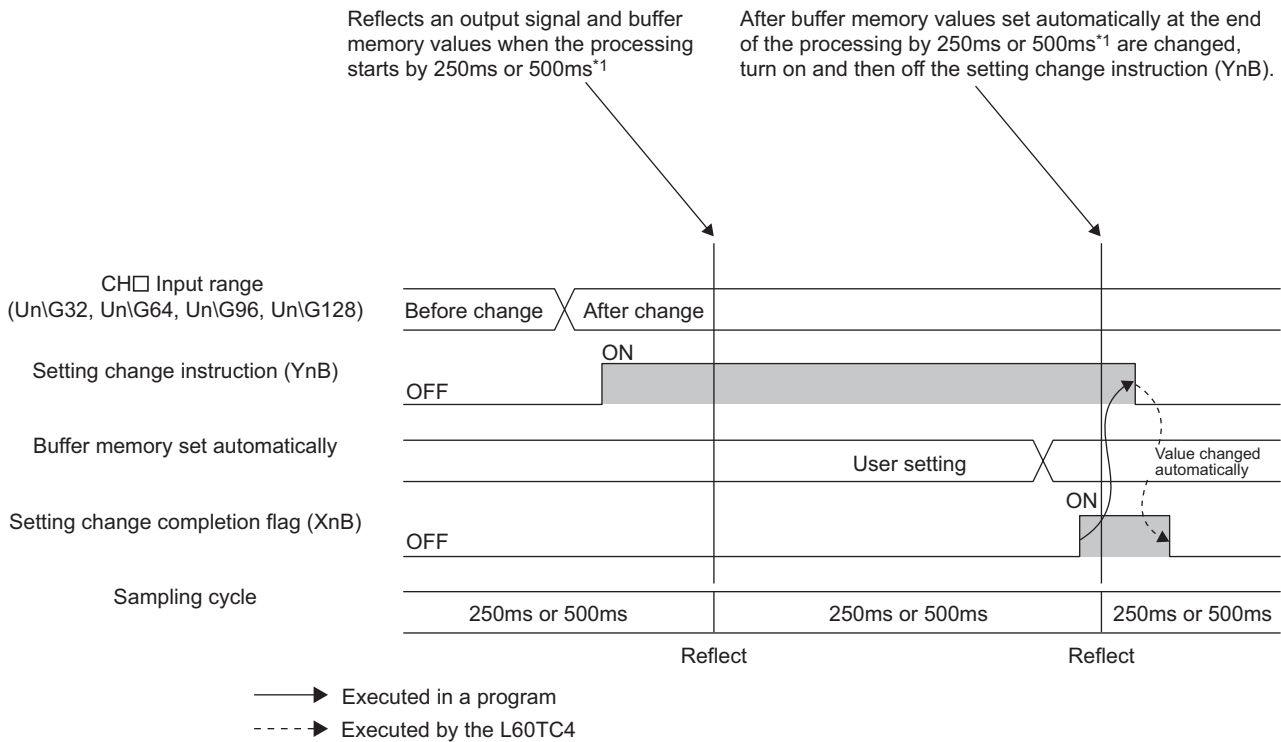

*1 This value differs depending on the setting under "Sampling Cycle Selection". (☞ Page 109, Section 7.2 (1) (b))

(1) Buffer memory automatically set

Refer to ☞ Page 351, Appendix 2 (12) (d).

8.3.4 Buffer memory data backup function

Common

This function allows buffer memory data to be stored in the non-volatile memory and backed up.

The backed-up data is transferred from the non-volatile memory to the buffer memory when the power is turned off and on or the CPU module is reset and the reset is cancelled. Therefore, temperature can be controlled without writing data when the power is turned off and on or the CPU module is reset and the reset is cancelled.

(1) Applicable buffer memory areas

Refer to the buffer memory assignment list.

☞ Page 44, Section 3.5

(2) Data write to non-volatile memory

This function can be used to back up data directly written in the buffer memory using the PID constants set with the auto tuning function and the programming tool. When data is written to non-volatile memory and the power is turned off and on or the CPU module is reset and the reset is cancelled, the buffer memory setting value is not required to be set again.

Point

For the function that allows PID constants to be automatically backed up after auto tuning, refer to ☞ Page 143, Section 8.2.7 (4).

To write data to non-volatile memory, turn off and on Setting value backup instruction (Yn8).

When data write to the non-volatile memory is completed, Backup of the set value completion flag (Xn8) turns on.

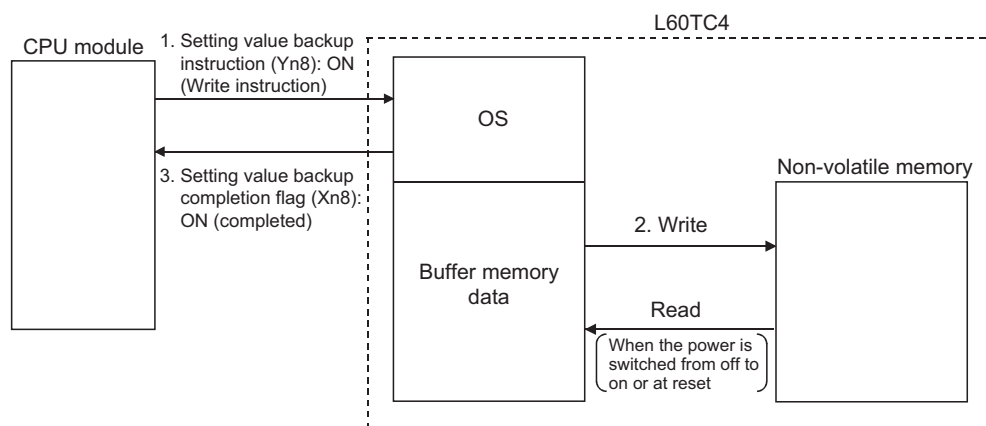

If data write to non-volatile memory does not complete, Backup of the set value fail flag (XnA) turns on.

(a) Setting change

Change the settings for buffer memory areas when Backup of the set value completion flag (Xn8) is off.

(3) Data read from non-volatile memory

Follow the instructions below.

- Turn off and on the power or reset the CPU module and cancel the reset.
- Set CH□ Memory of PID constants read instruction (Un\G62, Un\G94, Un\G126, Un\G158) to Requested (1). (☞ Page 377, Appendix 2 (36)) Data to be read are the PID constants and loop disconnection detection judgment time for the corresponding channel only. (☞ Page 374, Appendix 2 (33))

8.3.5 Error history function

Common

The error or alert occurred with the L60TC4 is stored in the buffer memory areas (Un\G1280 to Un\G1404) as history. Up to 16 error history data can be stored.

(1) Processing of the error history function

An error code and error occurrence time are stored starting from Error history No.1 (the start address is Un\G1280).

(2) How to check error history

The start address of the error history where the latest error is stored can be checked in Latest address of error history (Un\G1279).

Ex. If the third error occurred:
The third error is stored in Error history No.3 and 1296 (the start address of Error history No.3) is stored in Latest address of error history (Un\G1279).

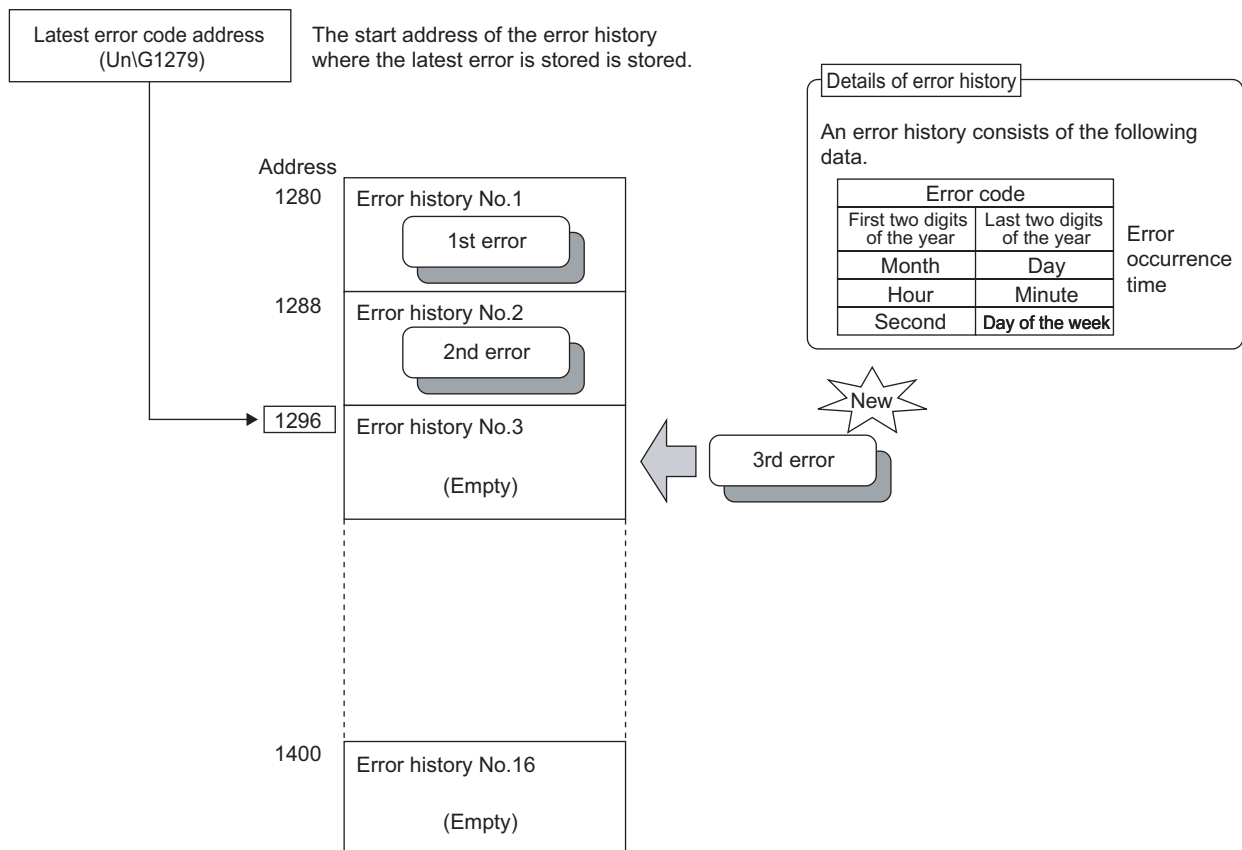

Ex. If the 17th error occurred:

The 17th error is stored in Error history No.1 and 1280 (the start address of Error history No.1) is overwritten in Latest address of error history (Un\G1279).

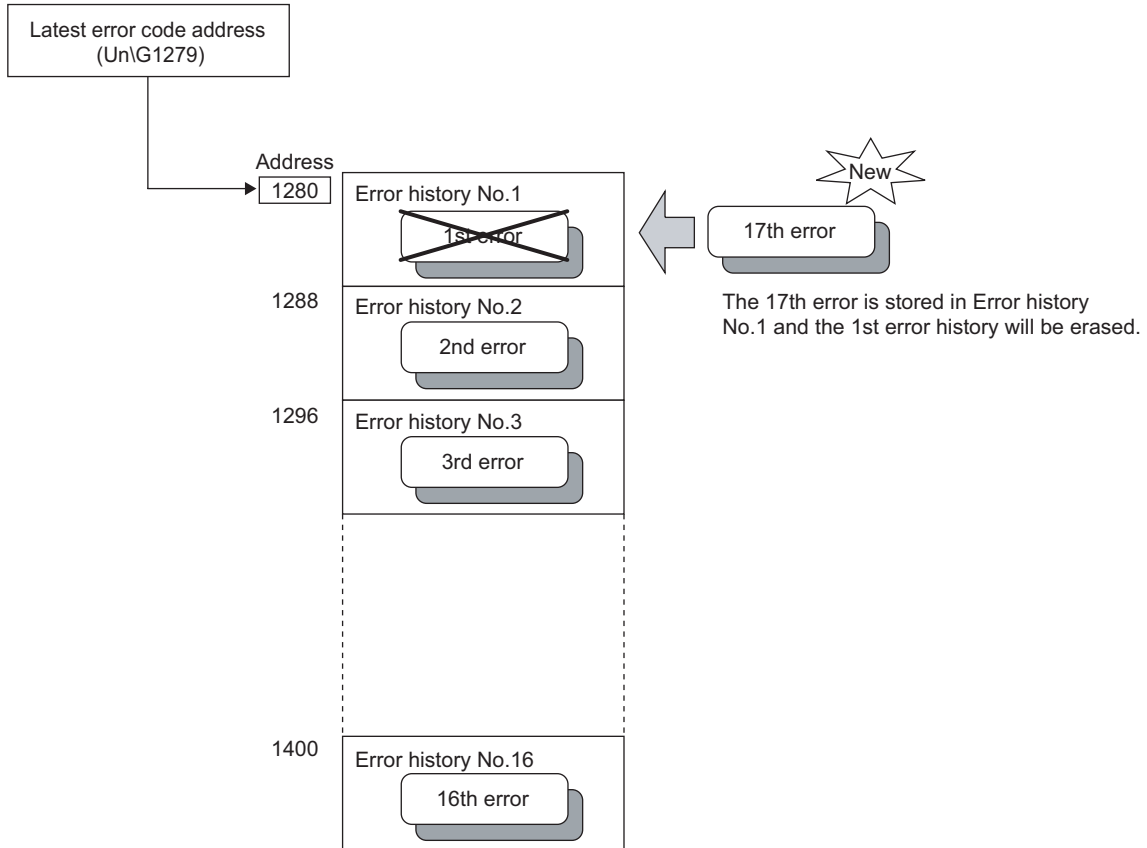

Point

- The same processing is performed for an alarm.
- When the storage area for error histories is full, data is overwritten starting from Error history No.1 (Un\G1280 to Un\G1284) and error history recording is continued. (The history before data overwritten is deleted.)
- Recorded error histories are cleared to 0 by turning off and on the power supply or by resetting the CPU module and canceling the reset.

8.3.6 Module error history collection function

Common

The errors and alarms occurred with the L60TC4 are collected into the CPU module.

The CPU module keeps the error information collected from the L60TC4 as a module error history in the memory where data is maintained even at the time of the power failure. Therefore, the information of the errors occurred with the L60TC4 can be kept even if the power is turned off and on or the CPU module is reset and the reset is cancelled.

(1) Example of the operation of the module error history collection function

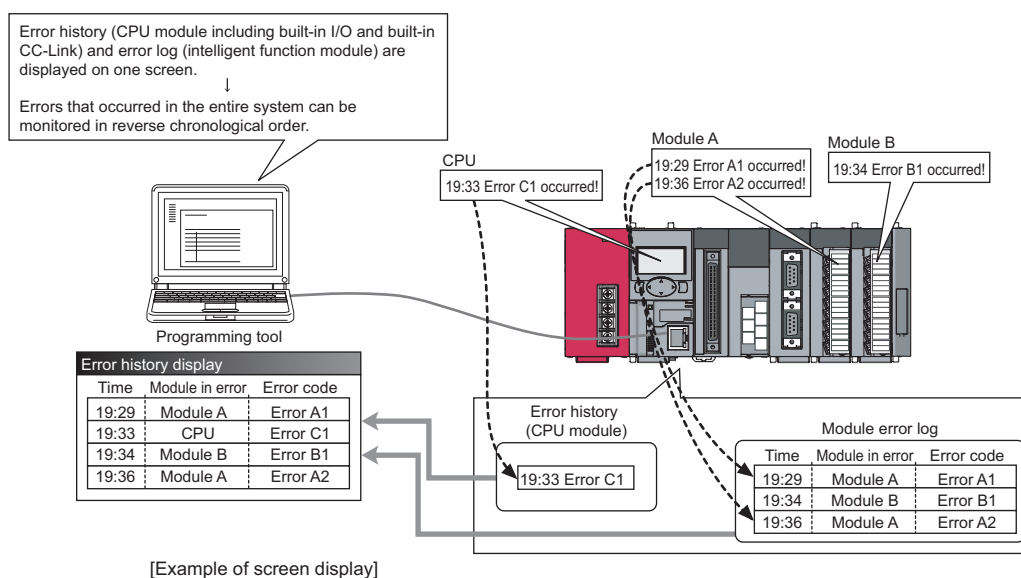

No.	Error Code	Date and Time	Model Name	Start I/O
00125	0070	2009/12/10 17:02:37	L60AD4	0030
00124	0070	2009/12/10 17:00:05	L60AD4	0030
00123	0CE4	2009/12/10 17:00:04	L26CPU-BT	----
00122	05DC	2009/12/10 16:15:50	L26CPU-BT	----
00121	0070	2009/12/10 15:59:30	L60DA4	0030
00120	0070	2009/12/10 15:45:02	L60DA4	0010
00119	05DC	2009/12/10 14:14:38	L26CPU-BT	----
00118	0070	2009/12/10 14:12:03	L60DA4	0010
00117	0CE4	2009/12/10 13:59:54	L26CPU-BT	----
00116	0CE4	2009/12/10 13:35:11	L26CPU-BT	----
00115	05DC	2009/12/10 11:11:45	L26CPU-BT	----
00114	0070	2009/12/10 11:07:05	L60AD4	0010
00113	0CE4	2009/12/10 11:07:04	L26CPU-BT	----
00112	0070	2009/12/10 11:03:49	L60AD4	0010
00111	0CE4	2009/12/10 11:03:48	L26CPU-BT	----
00110	05DC	2009/12/09 16:30:58	L26CPU-BT	----
00109	0070	2009/12/09 16:29:33	L60DA4	0010
00108	0070	2009/12/09 16:29:12	L60DA4	0010
00107	0638	2009/12/09 16:29:11	L26CPU-BT	----



For details on the module error history collection function, refer to the following.

MELSEC-L CPU Module User's Manual (Function Explanation, Program Fundamentals)

8.3.7 Error clear function

Common

When an error occurs, the error can be cleared on the system monitor.

Clicking the **Error Clear** button on the system monitor clears the error code stored in Error code (Un\G0) and turns off the ERR.LED. The operation is the same as when an error is cleared using Error reset instruction (Yn2).

However, the error history is not cleared.

For how to clear an error using Error reset instruction (Yn2), refer to the following.

- Error reset instruction (Yn2) (☞ Page 331, Appendix 1.2 (2))

☞ [Diagnostics] ⇨ [System Monitor...] ⇨ The module where an error occurred

The screenshot shows the 'Module's Detailed Information' window. It is divided into several sections:

- Monitor Status:** Includes a 'Monitoring' button and a yellow warning icon.
- Module:** Lists details for model L60TCTT4, I/O Address 0010, Mount Position Main block 0th slot, Product Information 13041000000000-A, and Production Number ---.
- Module Information:** Lists settings such as Module Access (Possible), Status of External Power Supply (---), Fuse Blown Status (---), Status of I/O Address Verify (Agree), I/O Clear / Hold Setting (---), Noise Filter Setting (---), Input Type (---), and Remote Password Setting Status (---).
- Error Information:** Shows the latest error code as 02B5. It includes buttons for 'Update Error History', 'Clear Error History', and 'Error Clear'. A table displays the error history:

No.	Error Code
1	02B5
2	0392
3	02B5

Below the table, it states: 'The error history is sequentially displayed from an old error. The latest error is displayed at the bottom line.'

- Error and Solution:** Contains a text area with the error message: 'The setting of the upper/lower limit value output limiter or the upper/lower limit setting limiter is invalid.' and a solution: 'Set the value where the upper limit value is greater than the lower limit value.'

At the bottom of the window, there are 'Stop Monitor' and 'Close' buttons.

CHAPTER 9 DISPLAY UNIT

This chapter describes the functions of the display unit that can be used with the L60TC4.
 For details on how to operate the display unit, the functions, and menu structure, refer to the following manual.

 MELSEC-L CPU Module User's Manual (Function Explanation, Program Fundamentals)

9.1 Display Unit

The display unit is an LCD display to be attached to the CPU module. By attaching it to the CPU module, the following operations can be performed without using any software package.

- Checking the system status
- Changing system set values (only for use as a temperature input module)

When a problem occurs, the cause of the problem can be identified by the displayed error information.

For details on how to check and clear errors from the display unit, refer to the following.

- Checking and clearing errors ( Page 248, Section 9.4)

Remark

To change system setting values in temperature control mode, use GX Works2. ( Page 107, CHAPTER 7)

9.2 Menu Transition

(1) Structure list

The following is the menu structure of "MOD MON/TEST" menu and "MOD SETTINGS" menu.

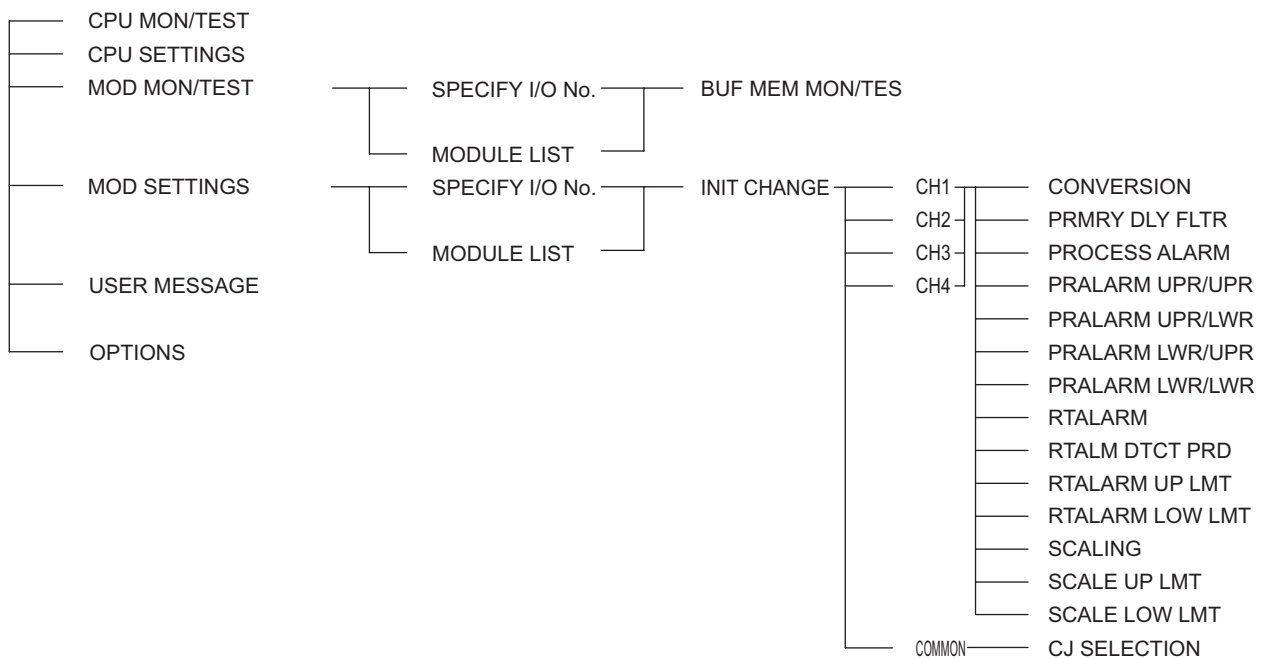

(2) Screen transition to the initial setting change screen

The following figure shows the screen transition to the initial setting change screen.

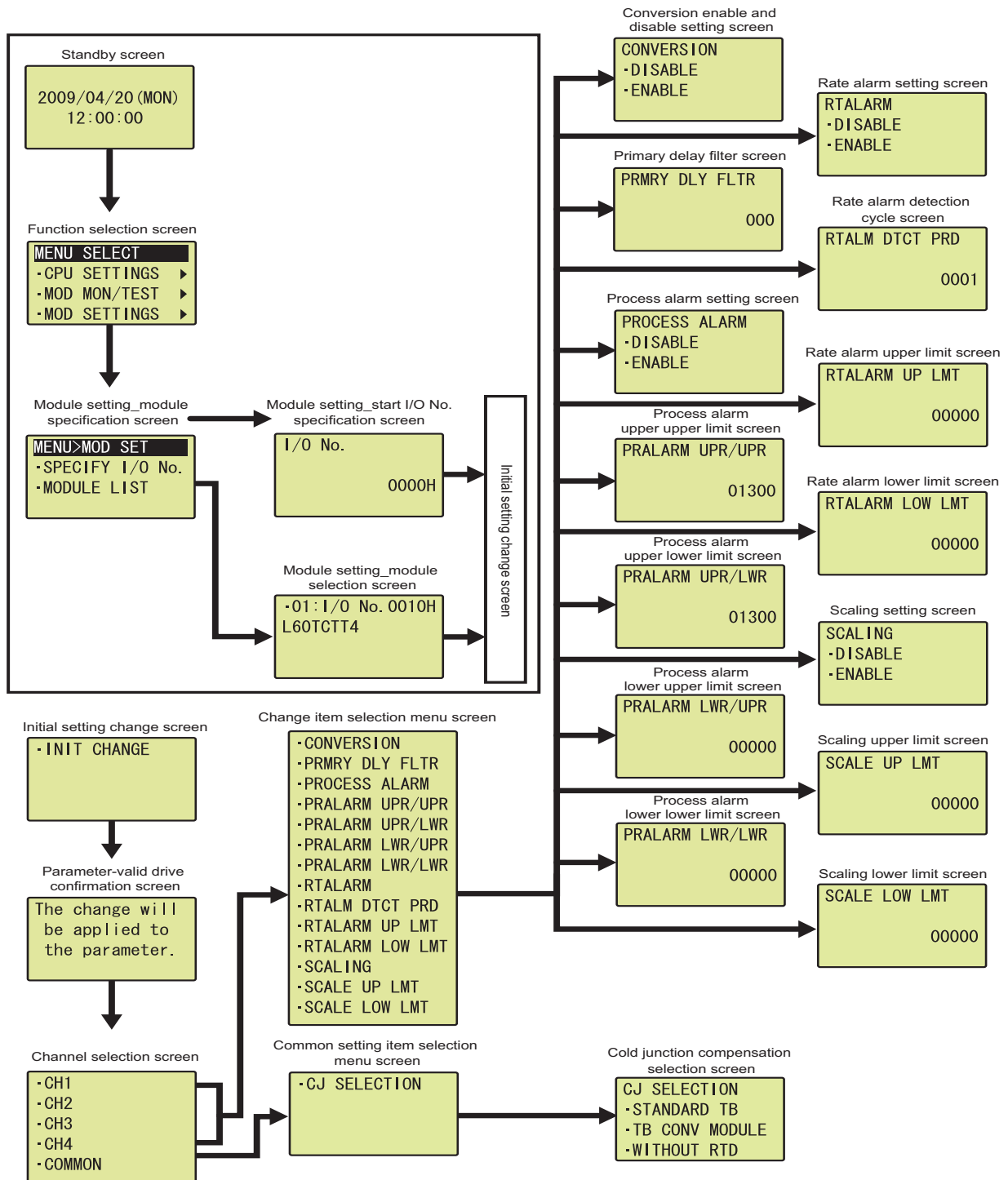

9.3 Setting Value Change Screen List

The following table shows the setting value change screen list.

(1) Displayed in English

Name		Screen format	Input limits	
Setting item	Screen display		Upper limit value	Lower limit value
Conversion enable/disable setting	CONVERSION	Selection	—	—
Primary delay digital filter setting	PRMRY DLY FLTR	Numeric	100	0
Process alarm alert output enable/disable setting	PROCESS ALARM	Selection	—	—
Process alarm upper upper limit value	PRALARM UPR/UPR	Numeric	32767	-32768
Process alarm upper lower limit value	PRALARM UPR/LWR	Numeric	32767	-32768
Process alarm lower upper limit value	PRALARM LWR/UPR	Numeric	32767	-32768
Process alarm lower lower limit value	PRALARM LWR/LWR	Numeric	32767	-32768
Rate alarm alert output enable/disable setting	RTALARM	Selection	—	—
Rate alarm alert detection period	RTALM DTCT PRD	Numeric	6000	1
Rate alarm upper limit value	RTALARM UP LMT	Numeric	32767	-32768
Rate alarm lower limit value	RTALARM LOW LMT	Numeric	32767	-32768
Process value (PV) scaling function enable/disable setting	SCALING	Selection	—	—
Process value (PV) scaling upper limit value	SCALE UP LMT	Numeric	32000	-32000
Process value (PV) scaling lower limit value	SCALE LOW LMT	Numeric	32000	-32000
Cold junction temperature compensation selection	CJ SELECTION	Selection	—	—

(2) Conversion enable/disable setting

Select "DISABLE" or "ENABLE" in the "Conversion enable and disable setting" screen.

"Conversion enable and disable setting" screen

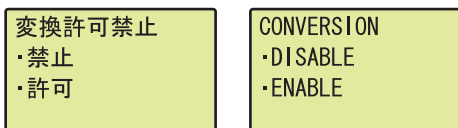

1. Use the ▲ and ▼ buttons to select "DISABLE" or "ENABLE", then make a confirmation with the button.

(3) Primary delay digital filter setting

Set the time constant for the primary delay digital filter in the "Primary delay filter" screen.

"Primary delay filter" screen

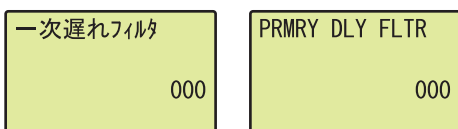

1. Move the cursor using the ◀ and ▶ buttons, then increment or decrement the value at the cursor, using the ▲ and ▼ buttons, respectively. Make a confirmation with the button.

Table of input items

Input item	Input range	
	Input upper limit	Input lower limit
Primary delay filter	100	0

(4) Process alarm setting

Select "DISABLE" or "ENABLE" in the "Process alarm setting" screen.

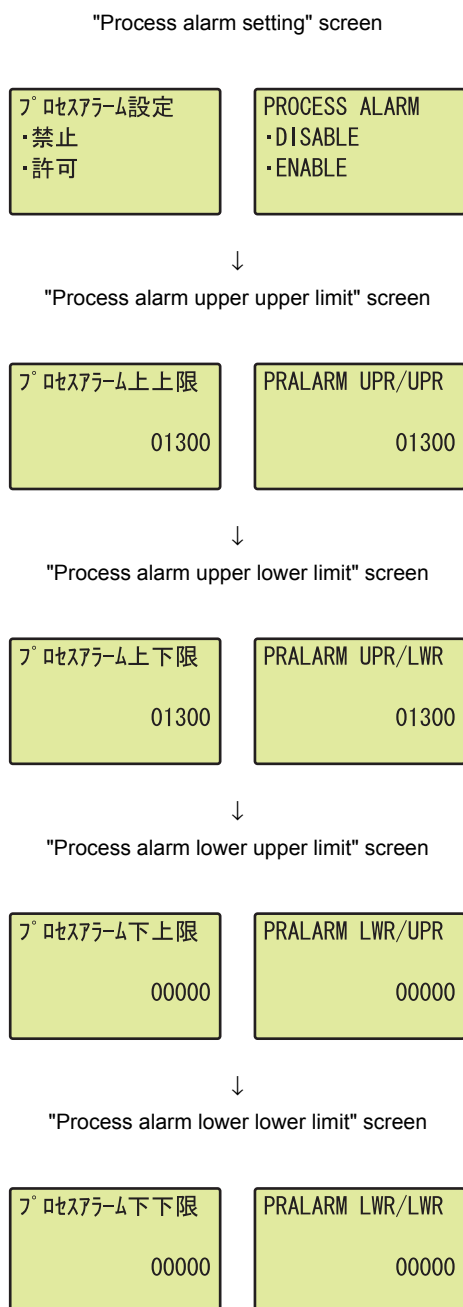

Table of input items

Input item	Input range	
	Input upper limit	Input lower limit
Process alarm upper upper limit	32767	-32768
Process alarm upper lower limit		
Process alarm lower upper limit		
Process alarm lower lower limit		

1. Use the ▲ and ▼ buttons to select "DISABLE" or "ENABLE", then make a confirmation with the **OK** button. (If "ENABLE" is selected, proceed to step 2.)
2. Move the cursor using the ◀ and ▶ buttons, then increment or decrement the value at the cursor, using the ▲ and ▼ buttons, respectively. Make a confirmation with the **OK** button.
3. Move the cursor using the ◀ and ▶ buttons, then increment or decrement the value at the cursor, using the ▲ and ▼ buttons, respectively. Make a confirmation with the **OK** button.
4. Move the cursor using the ◀ and ▶ buttons, then increment or decrement the value at the cursor, using the ▲ and ▼ buttons, respectively. Make a confirmation with the **OK** button.
5. Move the cursor using the ◀ and ▶ buttons, then increment or decrement the value at the cursor, using the ▲ and ▼ buttons, respectively. Make a confirmation with the **OK** button.

(5) Rate alarm setting

Select "DISABLE" or "ENABLE" in the "Rate alarm setting" screen.

"Rate alarm setting" screen

レートアラーム設定 ・禁止 ・許可	RTALARM ・DISABLE ・ENABLE
-------------------------	--------------------------------

↓

"Rate alarm detection period" screen

レートアラーム検出周期 0001	RTALM DTCT PRD 0001
---------------------	------------------------

↓

"Rate alarm upper limit" screen

レートアラーム上限 00000	RTALARM UP LMT 00000
--------------------	-------------------------

↓

"Rate alarm lower limit" screen

レートアラーム下限 00000	RTALARM LOW LMT 00000
--------------------	--------------------------

1. Use the ▲ and ▼ buttons to select "DISABLE" or "ENABLE", then make a confirmation with the button. (If "ENABLE" is selected, proceed to step 2.)
2. Move the cursor using the ◀ and ▶ buttons, then increment or decrement the value at the cursor, using the ▲ and ▼ buttons, respectively. Make a confirmation with the button.
3. Move the cursor using the ◀ and ▶ buttons, then increment or decrement the value at the cursor, using the ▲ and ▼ buttons, respectively. Make a confirmation with the button.
4. Move the cursor using the ◀ and ▶ buttons, then increment or decrement the value at the cursor, using the ▲ and ▼ buttons, respectively. Make a confirmation with the button.

Table of input items

Input item	Input range	
	Input upper limit	Input lower limit
Rate alarm detection period	6000	1
Rate alarm upper limit	32767	-32768
Rate alarm lower limit		

(6) Scaling setting

Select "DISABLE" or "ENABLE" in the "Scaling setting" screen.

"Scaling setting" screen

スケーリング設定 ・無効 ・有効	SCALING ・DISABLE ・ENABLE
------------------------	--------------------------------



"Scaling upper limit" screen

スケーリング上限 00000	SCALE UP LMT 00000
-----------------------	---------------------------



"Scaling lower limit" screen

スケーリング下限 00000	SCALE LOW LMT 00000
-----------------------	----------------------------

Table of input items

Input item	Input range	
	Input upper limit	Input lower limit
Scaling upper limit	32000	-32000
Scaling lower limit		

(7) Cold junction compensation selection

Select "STANDARD TB" or "WITHOUT RTD" in the "Cold junction compensation selection" screen.

"Cold junction compensation selection" screen

冷接点補償選択 ・標準端子台 ・端子台変換ユニット ・使用しない	CJ SELECTION ・STANDARD TB ・TB CONV MODULE ・WITHOUT RTD
---	---

1. Use the ▲ and ▼ buttons to select "DISABLE" or "ENABLE", then make a confirmation with the **OK** button. (If "ENABLE" is selected, proceed to step 2.)
2. Move the cursor using the ◀ and ▶ buttons, then increment or decrement the value at the cursor, using the ▲ and ▼ buttons, respectively. Make a confirmation with the **OK** button.
3. Move the cursor using the ◀ and ▶ buttons, then increment or decrement the value at the cursor, using the ▲ and ▼ buttons, respectively. Make a confirmation with the **OK** button.

9.4 Checking and Clearing Errors

By operation from the display unit, the error that occurred in the L60TC4 can be checked. The error that is occurring can also be cleared.

(1) Checking the error

The error that occurred in the L60TC4 can be checked by specifying the error code (Un\G0) from "Buffer memory monitor/test".

Ex. When an error occurred in the L60TC4 with the start I/O number 1

"Buffer memory monitor/test" screen

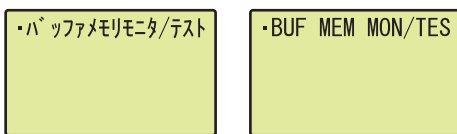

"Buffer memory address input format selection" screen

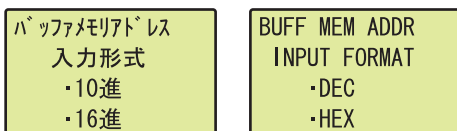

"Buffer memory address setting" screen

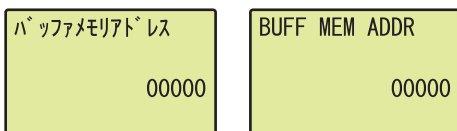

"Buffer memory monitor" screen

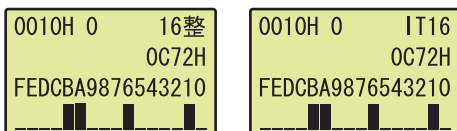

1. Press the button.

2. Use the and buttons to select "DEC" for the input format of the buffer memory address, then make a confirmation with the button.

3. Move the cursor using the and buttons, then increment or decrement the value at the cursor, using the and buttons, and set the value to 0. Make a confirmation with the button.

4. The error that occurred can be checked in the "Buffer memory monitor" screen.

(2) Clearing the error

To clear the error, remove the error cause and turn Error clear request (Yn2) off, on, and off from "Device monitor/test".

Ex. When an error occurred in the L60TC4 with the start I/O number 1

"CPU monitor/test" screen

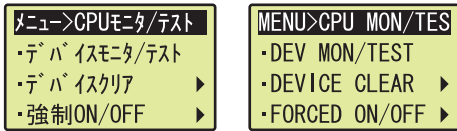

"Device monitor" screen

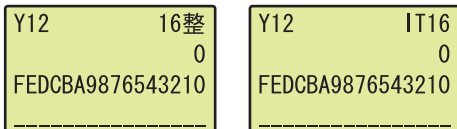

"Device test check" screen

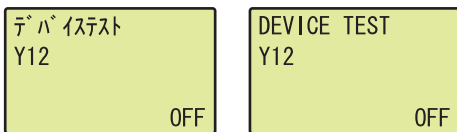

"Device test" screen

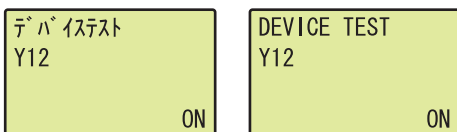

1. Use the ▲ and ▼ buttons to select "DEV MON/TEST", then make a confirmation with the **OK** button.

2. Set the device to Y and press the **OK** button.

3. Use the ▲ and ▼ buttons to set the device to Y12, then make a confirmation with the **OK** button.

4. Use the ▲ and ▼ buttons to switch ON/OFF. Press the **OK** button to set the value set in the device test.

CHAPTER 10 PROGRAMMING

This chapter describes the programs of the L60TC4.

When applying any of the program examples introduced in this chapter to the actual system, verify that the control of the target system has no problem thoroughly.

10.1 Programming Procedure

(1) Temperature input mode

Create a program that performs temperature conversion in the L60TC4 using the following procedure.

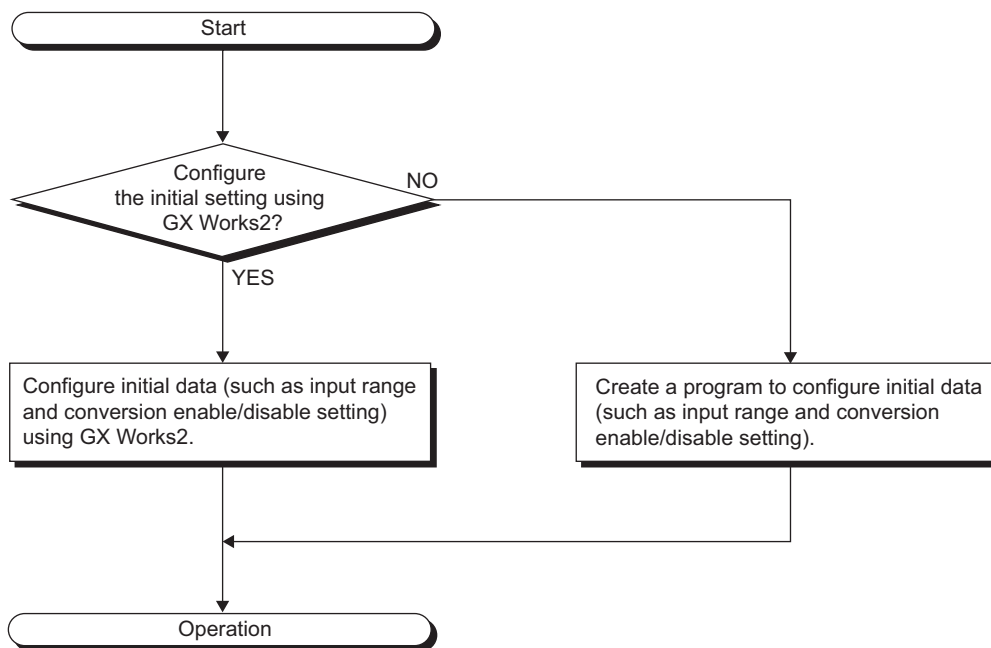

(2) Temperature control mode

Create a program that performs temperature control in the L60TC4 using the following procedure.

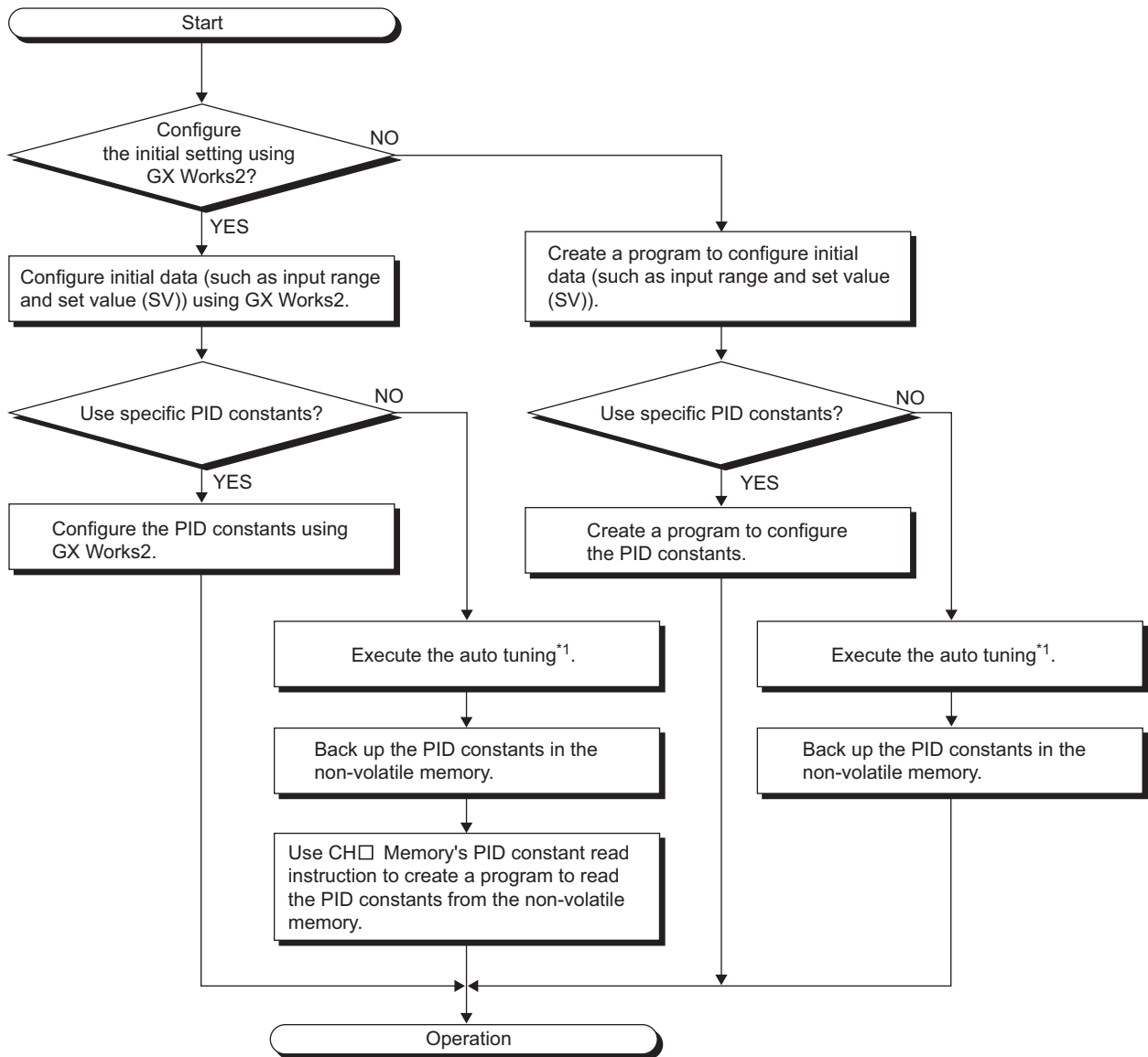

*1 In the standard control, the self-tuning can be selected if necessary.

10.2 When Using the Module in a Standard System Configuration

This section describes the following program examples.

Mode		Overview of the program example	Reference
Temperature input mode		This is a program example where the L60TC4 is used as a temperature input module.	Page 252, Section 10.2.1
Temperature control mode	Standard control	This is a program example for operations such as the auto tuning, self-tuning, and error code read.	Page 263, Section 10.2.2
	Heating-cooling control	This is a program example where the peak current suppression function and the simultaneous temperature rise function are used for the control.	Page 274, Section 10.2.3
		This is a program example for the heating-cooling control.	Page 288, Section 10.2.4

10.2.1 When using the L60TC4 as a temperature input module

This section describes the program example of when the L60TC4 is used as a temperature input module.

(1) System configuration

The following figure shows the system configuration of when the L60TC4 is used as a temperature input module.

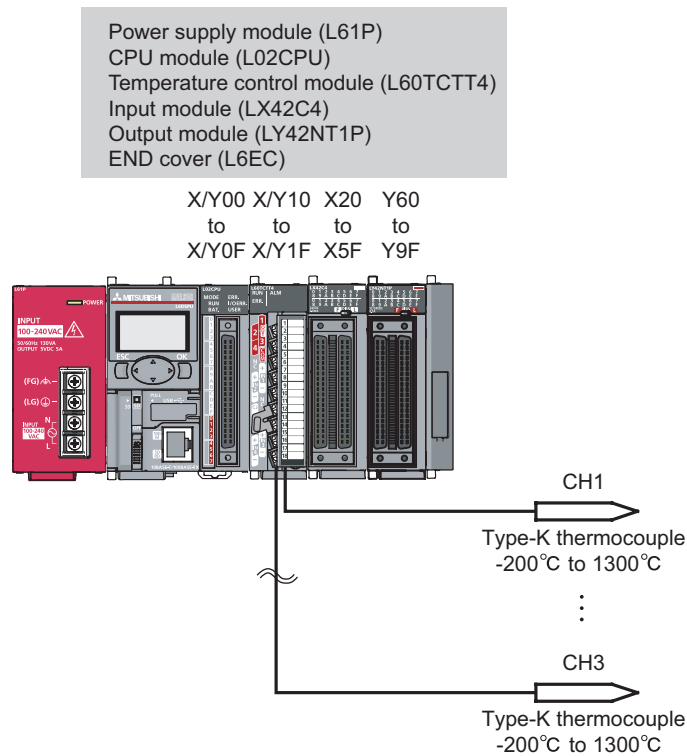

Point

- When using the L26CPU-BT, set the I/O assignment of the built-in CC-Link of the L26CPU-BT to X/YFE0 to X/YFFF so that the I/O assignment be the same as that of the system configuration above.
- When the L60TCTT4BW or the L60TCRT4BW is used, the I/O assignment is the same as that of the system configuration shown above.
 - Slot 0: 16 intelligent points
 - Slot 1: 64 input points
 - Slot 2: 64 output points

(2) Programming condition

This program is designed to read the temperatures measured by the thermocouple (K type, -200.0 to 1300.0°C) connected to CH1 to CH3.

An error code can be read and reset.

The following table lists other programming conditions.

Item	Description		
	CH1	CH2	CH3
Sampling cycle	250ms		
Temperature conversion method	Sampling processing	Sampling processing	Primary delay digital filter (time constant 1s)
Alert output function	—	<ul style="list-style-type: none"> • Process alarm lower lower limit value: 2000 (200.0°C) • Process alarm lower upper limit value: 2050 (205.0°C) • Process alarm upper lower limit value: 2950 (295.0°C) • Process alarm upper upper limit value: 3000 (300.0°C) 	<ul style="list-style-type: none"> • Rate alarm alert detection cycle: Four times (1s) • Rate alarm upper limit value: 50 (+5.0°C) • Rate alarm lower limit value: -50 (-5.0°C)

(3) Wiring example

The following figure shows a wiring example.

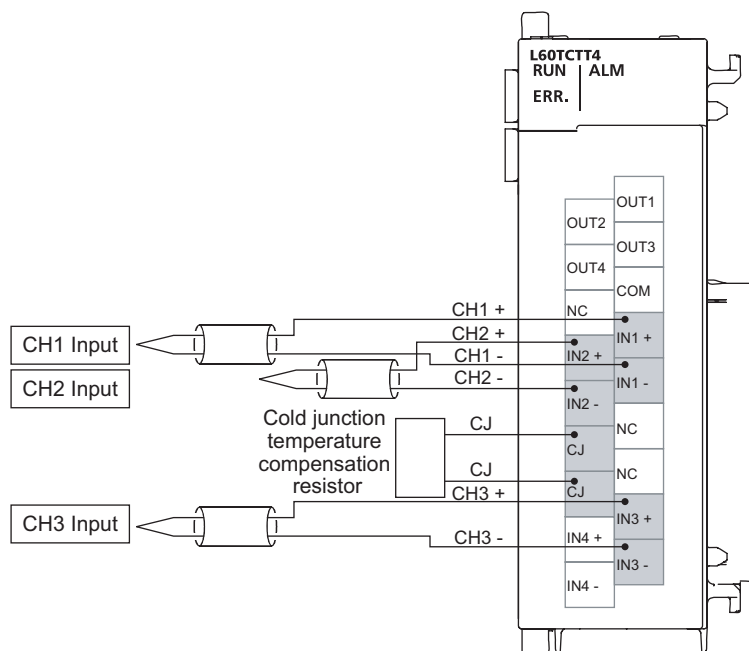

10.2 When Using the Module in a Standard System Configuration
10.2.1 When using the L60TC4 as a temperature input module

(4) Switch Setting

Configure settings such as the input mode selection and the auto-setting at the input range change as follows.

🖱️ Project window ⇨ [Intelligent Function Module] ⇨ [L60TCTT4] ⇨ [Switch Setting]

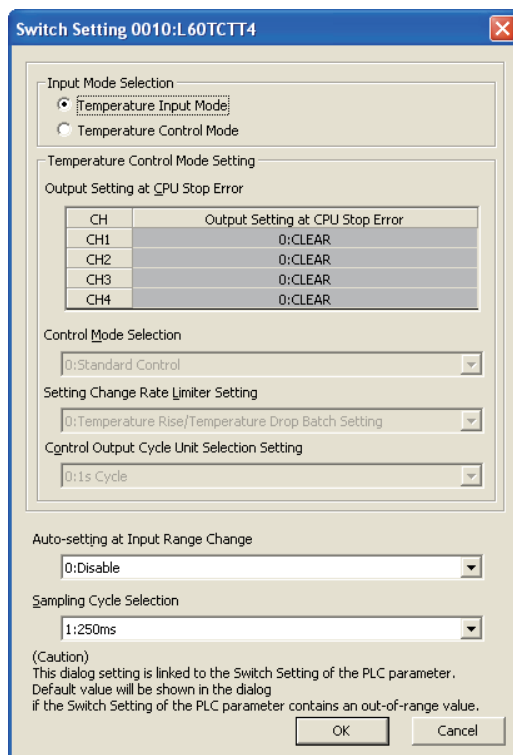

Item	Setting value
Input Mode Selection	Temperature Input Mode
Auto-setting at Input Range Change	0: Disable
Sampling Cycle Selection	1: 250ms

(5) Contents of the initial setting

Item	Description			
	CH1	CH2	CH3	CH4
Input range	49: Thermocouple K Measured Temperature Range (-200.0 to 1300.0°C)	49: Thermocouple K Measured Temperature Range (-200.0 to 1300.0°C)	49: Thermocouple K Measured Temperature Range (-200.0 to 1300.0°C)	2: ThermocoupleK Measured Temperature Range (0 to 1300.0°C)
Conversion enable/disable setting	0: Enable	0: Enable	0: Enable	1: Disable
Primary delay digital filter setting	0 s	0 s	1 s	0 s
Process alarm alert output enable/disable setting	1: Disable	0: Enable	1: Disable	1: Disable
Process alarm lower limit value	-200.0°C	200.0°C	-200.0°C	-200°C
Process alarm lower upper limit value	-200.0°C	205.0°C	-200.0°C	-200°C

Item	Description			
	CH1	CH2	CH3	CH4
Process alarm upper lower limit value	1300.0°C	295°C	1300.0°C	1300°C
Process alarm upper upper limit value	1300.0°C	300°C	1300.0°C	1300°C
Rate alarm alert output enable/disable setting	1: Disable	1: Disable	0: Enable	1: Disable
Rate alarm alert detection cycle	1 Times	1 Times	4 Times	1 Times
Rate alarm upper limit value	0.0°C	0.0°C	5.0°C	0°C
Rate alarm lower limit value	0.0°C	0.0°C	-5.0°C	0°C

(6) When using the parameter of an intelligent function module

(a) Devices used by a user

Device	Description	
X10	Module READY flag	L60TCTT4 (X10 to X1F)
X12	Error occurrence flag	
X22	Error code reset instruction	
X23	Operation mode setting instruction	LX42C4 (X20 to X5F)
X25	Temperature process value read instruction	
Y11	Setting/operation mode instruction	
Y12	Error reset instruction	L60TCTT4 (Y10 to Y1F)
Y1B	Setting change instruction	
Y60 to Y6F	Error code output	LY42NT1P (Y60 to Y9F)
D11	CH1 Temperature process value (PV)	
D12	CH2 Temperature process value (PV)	
D13	CH3 Temperature process value (PV)	
D50	Error code	Devices where data is written by auto refresh
D51	CH1 Temperature process value (PV)	
D52	CH2 Temperature process value (PV)	
D53	CH3 Temperature process value (PV)	
D55	CH2 Alert definition	
D56	CH3 Alert definition	
D60	Temperature conversion completion flag	

(b) Parameter setting

Set the contents of initial settings in the parameter.

1. Open the "Parameter" window.

Project window ⇨ [Intelligent Function Module] ⇨ [L60TCTT4] ⇨ [Switch Setting]

2. Click **Clear Value for Gray Cells** to set items unnecessary for the mode set on Switch Setting to 0.

3. Set the parameter.

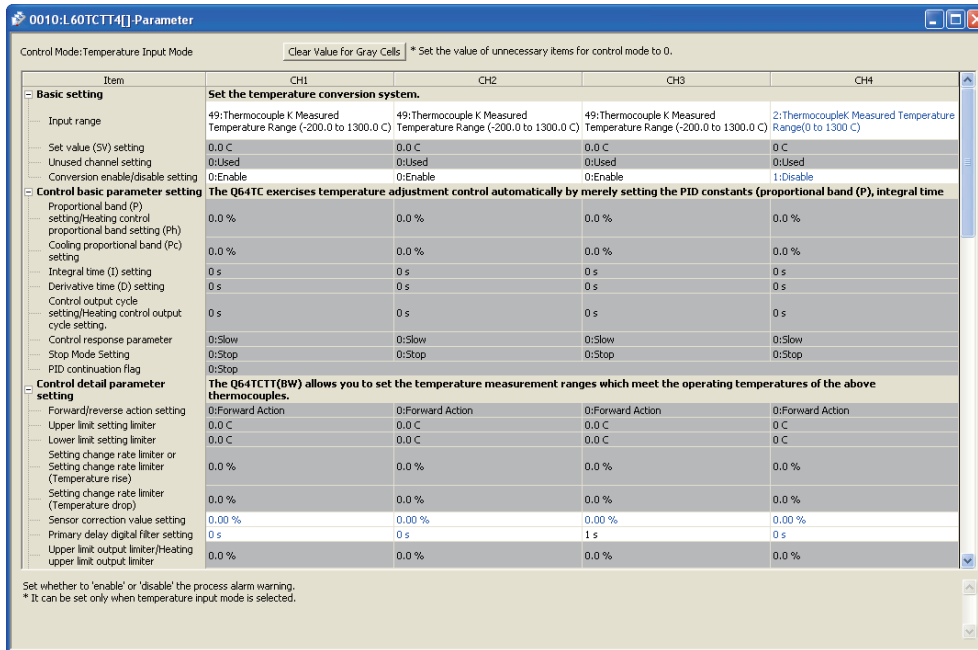

Item	Description	Setting value			
		CH1	CH2	CH3	CH4
Input range	Set the temperature sensor used for the L60TC4 and the measurement range.	49: Thermocouple K Measured Temperature Range (-200.0 to 1300.0°C)	49: Thermocouple K Measured Temperature Range (-200.0 to 1300.0°C)	49: Thermocouple K Measured Temperature Range (-200.0 to 1300.0°C)	2: ThermocoupleK Measured Temperature Range (0 to 1300°C)
Conversion enable/disable setting	Set whether to enable or disable temperature conversion for each channel.	0: Enable	0: Enable	0: Enable	1: Disable
Primary delay digital filter setting	Set the primary delay digital filter that smoothes the temperature process value (PV).	0 s	0 s	1 s	0 s
Process alarm alert output enable/disable setting	Set whether to enable or disable the process alarm alert output for each channel.	1: Disable	0: Enable	1: Disable	1: Disable
Process alarm lower lower limit value	Set the process alarm lower lower limit value.	0.0°C	200.0°C	0.0°C	0°C
Process alarm lower upper limit value	Set the process alarm lower upper limit value.	0.0°C	205.0°C	0.0°C	0°C

Item	Description	Setting value			
		CH1	CH2	CH3	CH4
Process alarm upper lower limit value	Set the process alarm upper lower limit value.	1300.0°C	295.0°C	1300.0°C	1300°C
Process alarm upper upper limit value	Set the process alarm upper upper limit value.	1300.0°C	300.0°C	1300.0°C	1300°C
Rate alarm alert output enable/disable setting	Set whether to enable or disable the rate alarm alert output for each channel.	1: Disable	1: Disable	0: Enable	1: Disable
Rate alarm alert detection cycle	Set the cycle for checking the temperature process value (PV) for the rate alarm.	1 Times	1 Times	4 Times	1 Times
Rate alarm upper limit value	Set the rate alarm upper limit value.	0.0°C	0.0°C	5.0°C	0°C
Rate alarm lower limit value	Set the rate alarm lower limit value.	0.0°C	0.0°C	-5.0°C	0°C

(c) Auto refresh setting

Set the device to be automatically refreshed.

Project window ⇒ [Intelligent Function Module] ⇒ [L60TCTT4] ⇒ [Auto_Refresh]

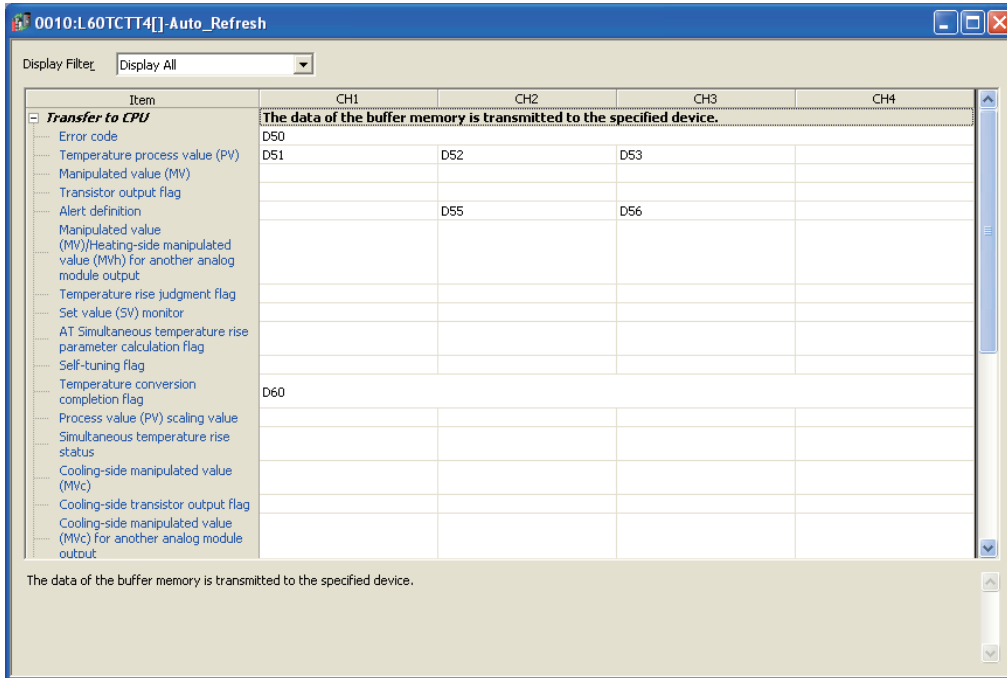

Item	Description	Setting value			
		CH1	CH2	CH3	CH4
Error code	An error code or alarm code is stored.	D50			
Temperature process value (PV)	The detected temperature value where sensor correction was performed is stored.	D51	D52	D53	—
Alert definition	Bits corresponding to alerts detected in each channel become 1.	—	D55	D56	—
Temperature conversion completion flag	This flag checks whether the temperature conversion has started properly for each channel.	D60			

(d) Writing parameter of an intelligent function module

Write the set parameter to the CPU module. Then reset the CPU module or turn off and on the power supply of the programmable controller.

 [Online] ⇨ [Write to PLC...]

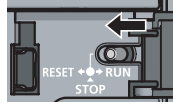

or Power OFF → ON

(e) Program example

- Program that changes the setting/operation mode

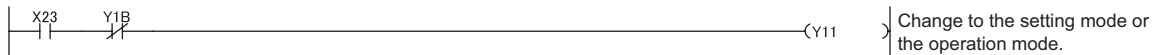

- Program that reads the temperature process value (PV) and takes action when a process alarm or a rate alarm occurs

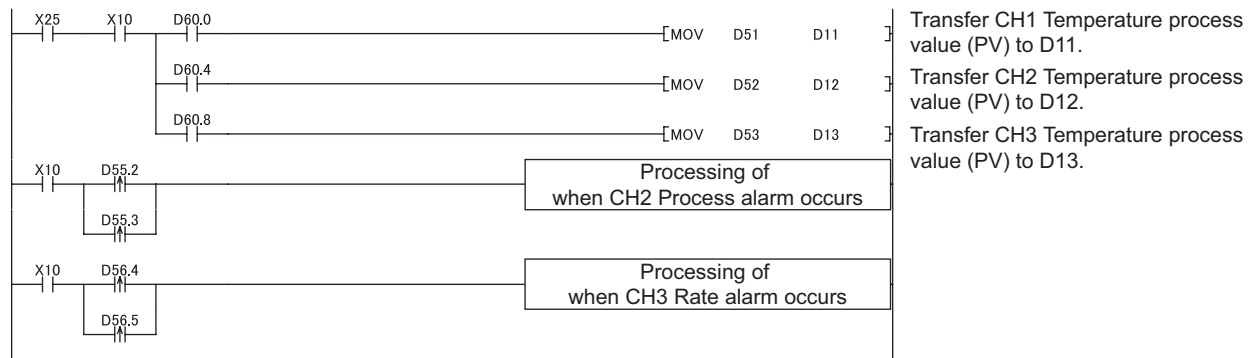

- Program that reads an error code

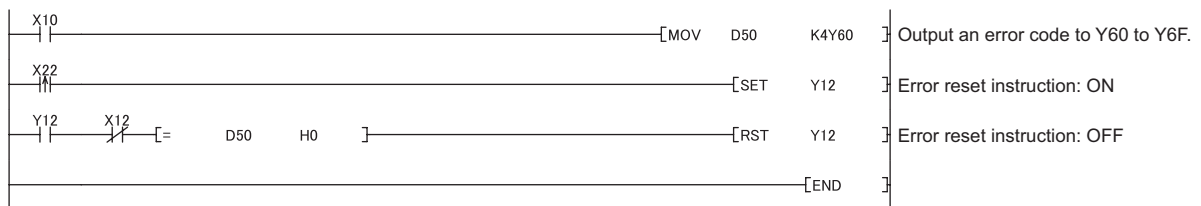

10.2 When Using the Module in a Standard System Configuration
 10.2.1 When using the L60TC4 as a temperature input module

(7) Program example of when not using the parameter of an intelligent function module

(a) Devices used by a user

Device	Description	
X10	Module READY flag	L60TCTT4 (X10 to X1F)
X12	Error occurrence flag	
X13	Hardware error flag	
X1B	Setting change completion flag	
X20	Set value write instruction	LX42C4 (X20 to X5F)
X22	Error code reset instruction	
X23	Operation mode setting instruction	
X25	Temperature process value read instruction	
Y11	Setting/operation mode status	L60TCTT4 (Y10 to Y1F)
Y12	Error reset instruction	
Y1B	Setting change instruction	
Y60 to Y6F	Error code output	LY42NT1P (Y60 to Y9F)
D11	CH1 Temperature process value (PV)	
D12	CH2 Temperature process value (PV)	
D13	CH3 Temperature process value (PV)	
D50	Error code	
D55	CH2 Alert definition	
D56	CH3 Alert definition	
D60	Temperature conversion completion flag	
M0	For writing set value 0	
M1	For writing set value 1	
M2	For writing set value 2	

(b) Program example

- Program that changes the setting/operation mode

The program is the same as that of when the parameter of the intelligent function module is used.

(☞ Page 259, Section 10.2.1 (6) (e))

- Initial setting program

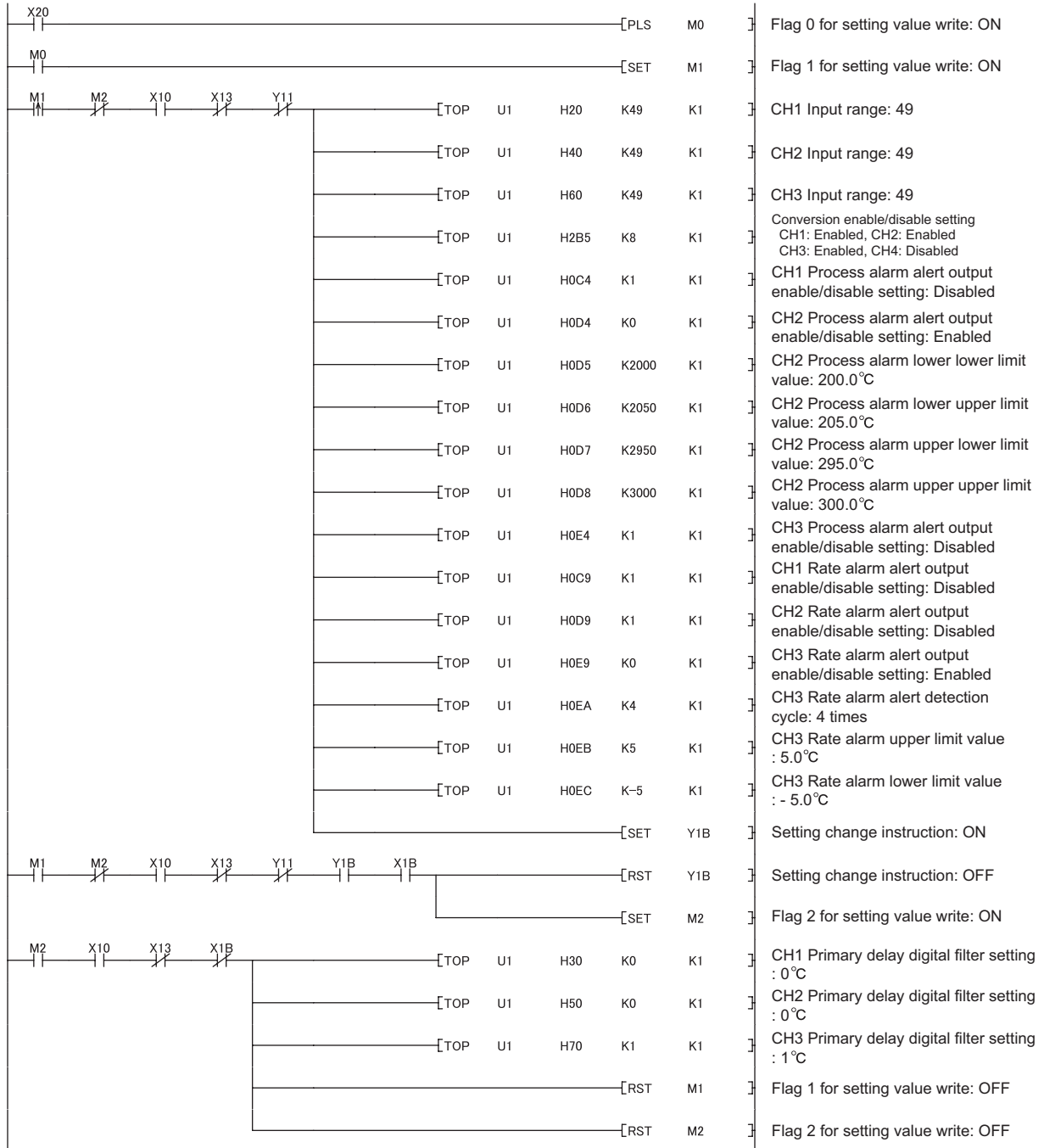

10.2 When Using the Module in a Standard System Configuration
10.2.1 When using the L60TC4 as a temperature input module

- Program that reads the temperature process value (PV) and takes action when a process alarm or a rate alarm occurs

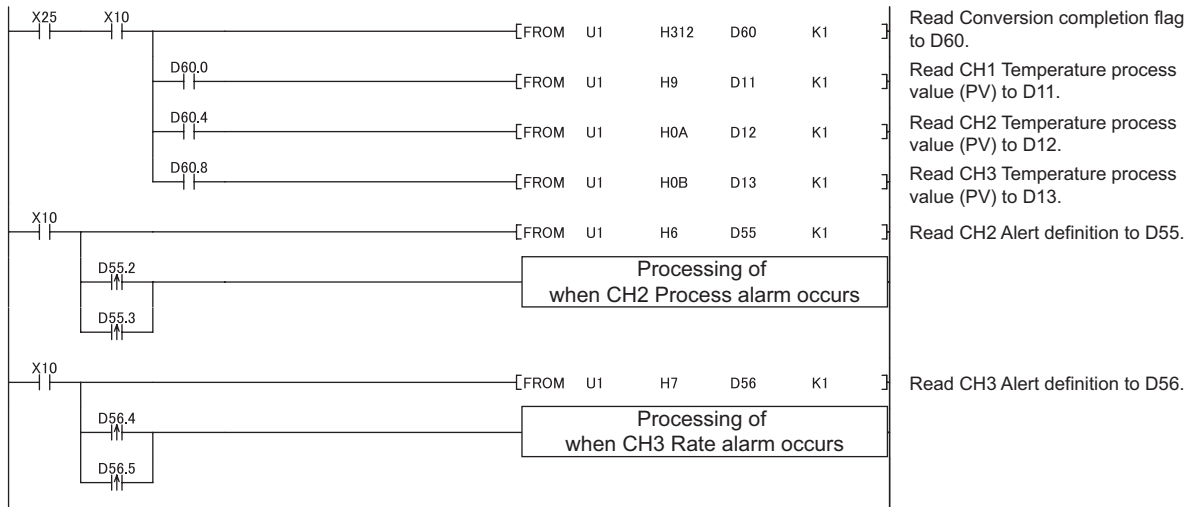

- Program that reads an error code

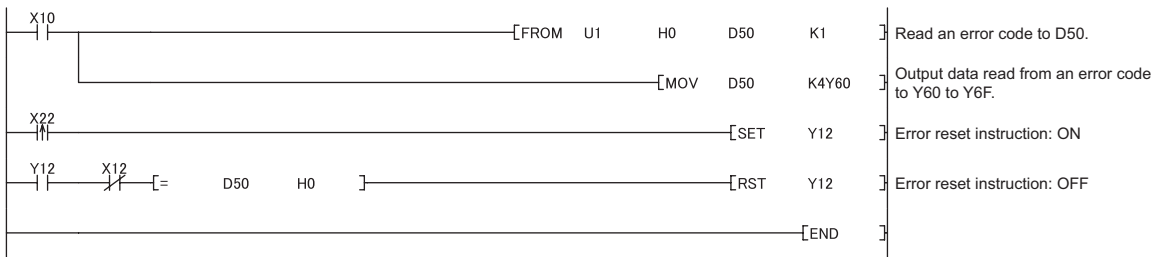

10.2.2 Standard control (such as auto tuning, self-tuning, and error code read)

This section describes the program example for operations such as the auto tuning, self-tuning, and error code read.

10

(1) System configuration

The following figure shows the system configuration for operations such as the auto tuning, self-tuning, and error code read.

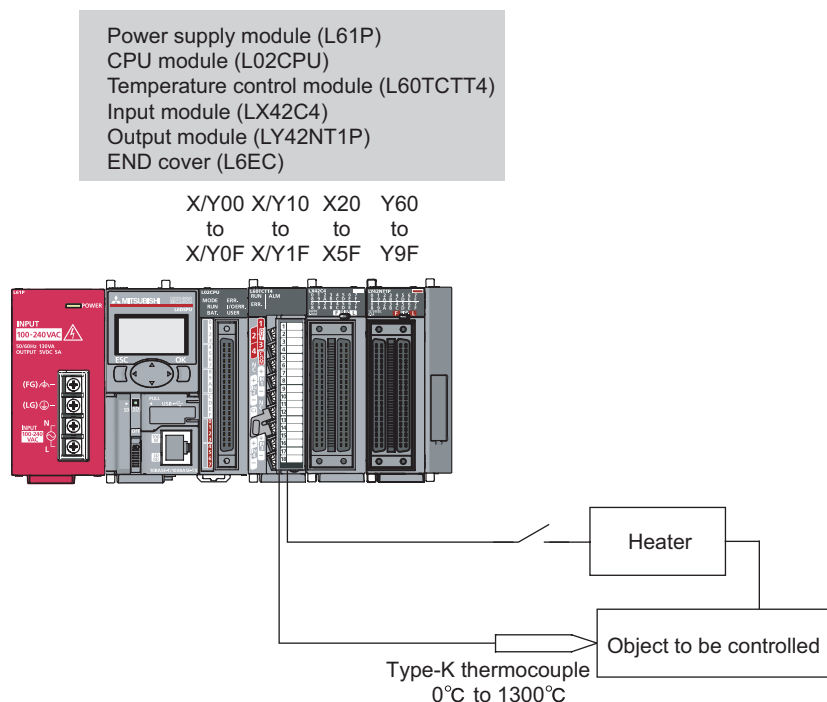

Point

- When using the L26CPU-BT, set the I/O assignment of the built-in CC-Link of the L26CPU-BT to X/YFE0 to X/YFFF so that the I/O assignment be the same as that of the system configuration above.
- When the L60TCTT4BW or the L60TCRT4BW is used, the I/O assignment is the same as that of the system configuration shown above.
 - Slot 0: 16 intelligent points
 - Slot 1: 64 input points
 - Slot 2: 64 output points

(2) Programming condition

This program is designed to read the temperatures measured by the thermocouple (K type, 0°C to 1300°C) connected to CH1 for the control.

An error code can be read and reset.

The self-tuning function automatically sets the PID constants optimal to CH1.

(3) Wiring example

The following figure shows a wiring example.

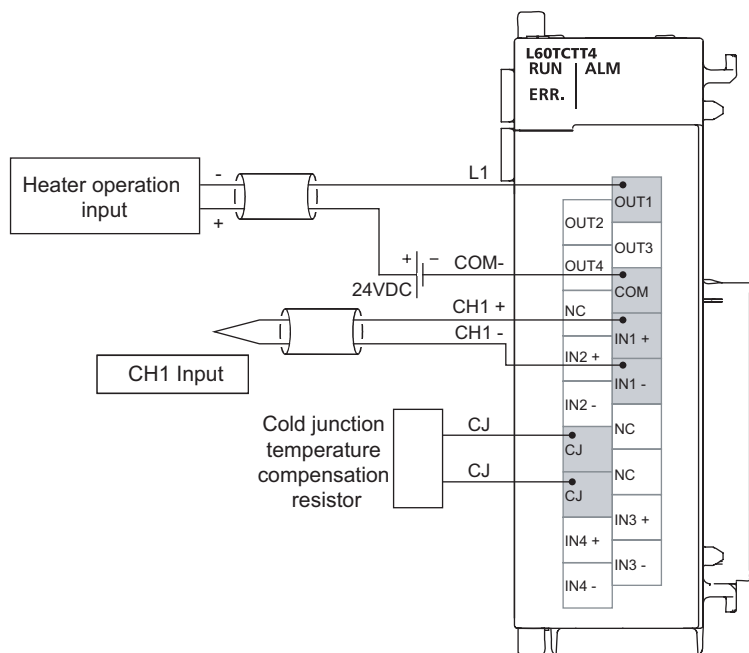

(4) Switch Setting

Configure settings such as the input mode selection and the auto-setting at the input range change as follows.

Project window ⇨ [Intelligent Function Module] ⇨ [L60TCTT4] ⇨ [Switch Setting]

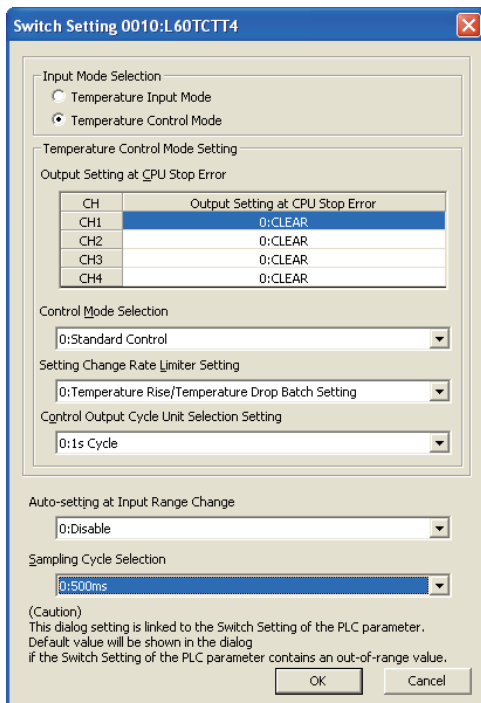

Item	Set value				
	CH1	CH2	CH3	CH4	
Input Mode Selection	Temperature Control Mode				
Temperature Control Mode Setting	Output Setting at CPU Stop Error	0: CLEAR	0: CLEAR	0: CLEAR	0: CLEAR
	Control Mode Selection	0: Standard Control			
	Setting Change Rate Limiter Setting	0: Temperature Rise/Temperature Drop Batch Setting			
	Control Output Cycle Unit Selection Setting	0: 1s Cycle			
Auto-setting at Input Range Change	0: Disable				
Sampling Cycle Selection	0: 500ms				

10.2 When Using the Module in a Standard System Configuration
 10.2.2 Standard control (such as auto-tuning, self-tuning, and error code read)

(5) Contents of the initial setting

Item	Description			
	CH1	CH2	CH3	CH4
Input range	2: Thermocouple K Measured Temperature Range (0 to 1300°C)	2: Thermocouple K Measured Temperature Range (0 to 1300°C)	2: Thermocouple K Measured Temperature Range (0 to 1300°C)	2: Thermocouple K Measured Temperature Range (0 to 1300°C)
Set value (SV) setting	200°C	0°C	0°C	0°C
Unused channel setting	0: Used	1: Unused	1: Unused	1: Unused
Control output cycle setting	30 s	30 s	30 s	30 s
Upper limit setting limiter	400°C	1300°C	1300°C	1300°C
Lower limit setting limiter	0°C	0°C	0°C	0°C
Self-tuning setting*1	1: Starting ST (PID Constant Only)	0: Do Not Run the ST	0: Do Not Run the ST	0: Do Not Run the ST
Alert 1 mode setting	1: Upper Limit Input Alert	0: Not Warning	0: Not Warning	0: Not Warning
Alert set value 1	500°C	0°C	0°C	0°C

*1 This setting is necessary only when the self-tuning function is used.

(6) When using the parameter of an intelligent function module

(a) Devices used by a user

Device	Description	
X10	Module READY flag	L60TCTT4 (X10 to X1F)
X12	Error occurrence flag	
X22	Error code reset instruction	LX42C4 (X20 to X5F)
X23	Operation mode setting instruction	
X24	Memory of PID constants read instruction	
X30	CH1 Set value (SV) change instruction	
Y11	Setting/operation mode instruction	L60TCTT4 (Y10 to Y1F)
Y12	Error reset instruction	
Y18	Set value backup instruction	
Y1B	Setting change instruction	
Y60 to Y6F	Error code output	LY42NT1P (Y60 to Y9F)
D50	Error code	Devices where data is written by auto refresh
D51	CH1 Temperature process value (PV)	
M20 to M23	CH□ Read completion flag	
M24 to M27	CH□ Write completion flag	

(b) Parameter setting

Set the contents of initial settings in the parameter.

1. Open the "Parameter" window.

Project window ⇨ [Intelligent Function Module] ⇨ [L60TCTT4] ⇨ [Parameter]

2. Click Clear Value for Gray Cells to set items unnecessary for the mode set on Switch Setting to 0.

3. Set the parameter.

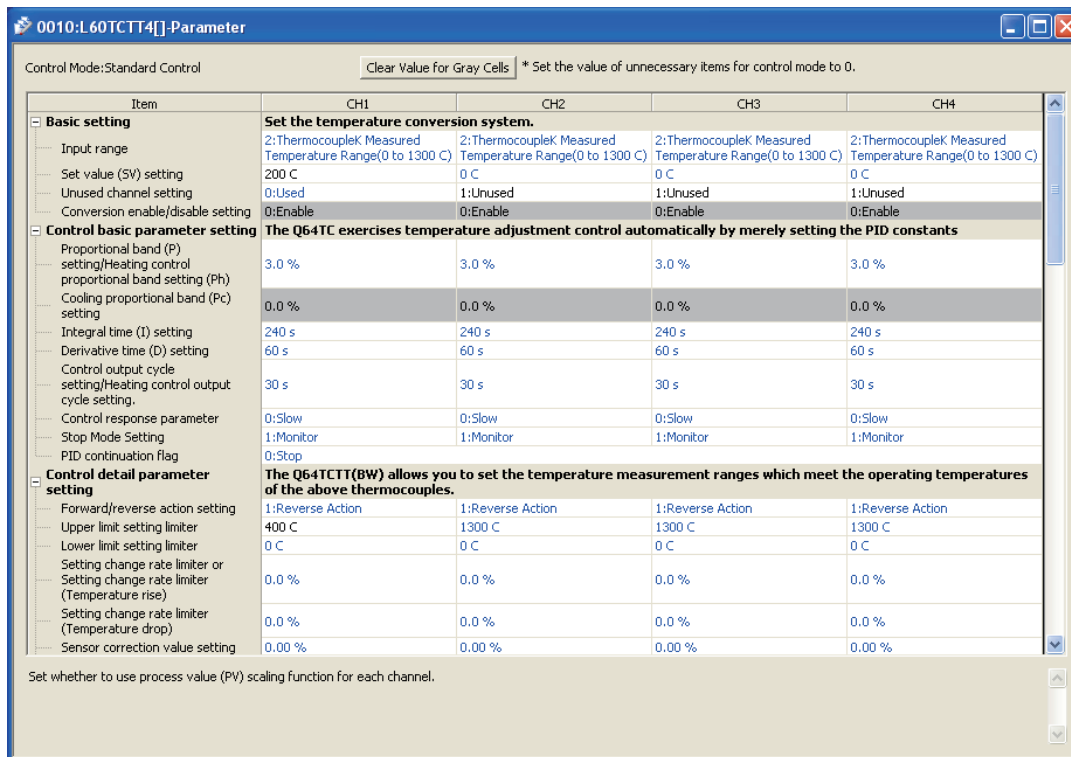

Item	Description	Setting value			
		CH1	CH2	CH3	CH4
Input range	Set the temperature sensor used for the L60TC4 and the measurement range.	2: ThermocoupleK Measured Temperature Range (0 to 1300°C)	2: ThermocoupleK Measured Temperature Range (0 to 1300°C)	2: ThermocoupleK Measured Temperature Range (0 to 1300°C)	2: ThermocoupleK Measured Temperature Range (0 to 1300°C)
Set value (SV) setting	Set the target temperature value of PID control.	200°C	0°C	0°C	0°C
Unused channel setting	Configure this setting when the channels where the temperature control is not performed and the temperature sensor is not connected are set to be unused.	0: Used	1: Unused	1: Unused	1: Unused
Control output cycle setting/Heating control output cycle setting	Set the pulse cycle (ON/OFF cycle) of the transistor output.	30 s	30 s	30 s	30 s
Upper limit setting limiter	Set the upper limit of the set value (SV).	400°C	1300°C	1300°C	1300°C

10.2 When Using the Module in a Standard System Configuration
10.2.2 Standard control (such as auto-tuning, self-tuning, and error code read)

Item	Description	Setting value			
		CH1	CH2	CH3	CH4
Lower limit setting limiter	Set the lower limit of the set value (SV).	0°C	0°C	0°C	0°C
Self-tuning setting ^{*1}	Set the operation of the self-tuning.	1: Starting ST (PID Constant Only)	0: Do Not Run the ST	0: Do Not Run the ST	0: Do Not Run the ST
Alert 1 mode setting	Set the alert mode.	1: Upper Limit Input Alert	0: Not Warning	0: Not Warning	0: Not Warning
Alert set value 1	Set the temperature where CH□ Alert 1 (b8 of Un\G5 to Un\G8) turns on depending on the selected alert mode.	500°C	—	—	—

*1 This setting is necessary only when the self-tuning function is used.

(c) Auto refresh setting

Set the device to be automatically refreshed.

 Project window ⇒ [Intelligent Function Module] ⇒ [L60TCTT4] ⇒ [Auto_Refresh]

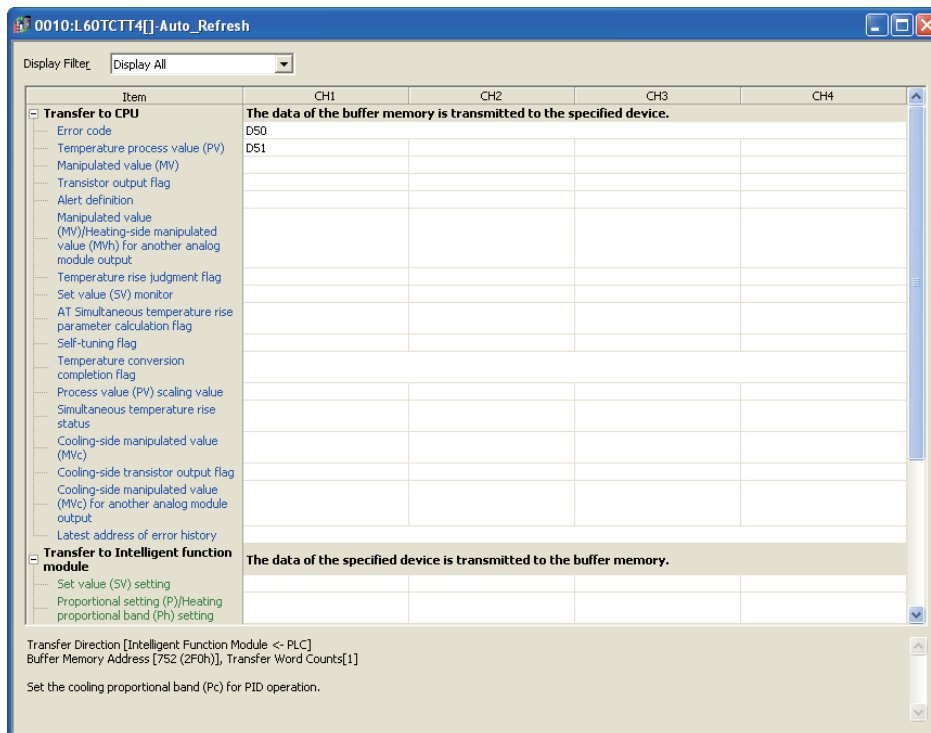

Item	Description	Set value			
		CH1	CH2	CH3	CH4
Error code	An error code or alarm code is stored.	D50			
Temperature process value (PV)	The detected temperature value where sensor correction was performed is stored.	D51	—	—	—

(d) Writing parameter of an intelligent function module

Write the set parameter to the CPU module. Then reset the CPU module or turn off and on the power supply of the programmable controller.

[Online] ⇨ [Write to PLC...]

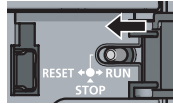

or Power OFF → ON

(e) Performing auto tuning

Set the "Automatic backup setting after auto tuning of PID constants" to "ON" and perform the auto tuning.

[Tool] ⇨ [Intelligent Function Module Tool] ⇨ [Temperature Control Module]
⇨ [Auto Tuning...] ⇨ [L60TCTT4] ⇨

Item	CH1	CH2	CH3	CH4
PID control				
PID control operation status				
Process value (PV)	0 C	0 C	0 C	0 C
Set value (SV)	200 C	0 C	0 C	0 C
Manipulated value (MV)/Heating-side manipulated value (Mvh)	-5.0 %	-5.0 %	-5.0 %	-5.0 %
Cooling-side manipulated value (Mvc)	0.0 %	0.0 %	0.0 %	0.0 %
PID constant				
PID constant current value				
Proportional band (P) setting/Heating control proportional band setting (Ph)	3.0 %	3.0 %	3.0 %	3.0 %
Cooling-side proportional band (Pc) setting	0.0 %	0.0 %	0.0 %	0.0 %
Integral time (I) setting	240 s	240 s	240 s	240 s
Derivative time (D) setting	60 s	60 s	60 s	60 s
Loop disconnection detection judgment time	480 s	480 s	480 s	480 s
Auto tuning execution				
Executes auto tuning.				
Auto tuning start	Start	Start	Start	Start
Auto tuning stop	Stop	Stop	Stop	Stop
Status	Not executed	Not executed	Not executed	Not executed
Result of automatic backup of PID constant	----	----	----	----

The time between the start and completion of auto tuning depends on the object to be controlled.
After auto tuning starts, this window can be closed.

10.2 When Using the Module in a Standard System Configuration
10.2.2 Standard control (such as auto tuning, self-tuning, and error code read)

(f) Program example

- Program that changes the setting/operation mode

This program is the same as that of when it is used as a temperature input module. (☞ Page 259, Section 10.2.1 (6) (e))

- Program that reads the PID constants from the non-volatile memory

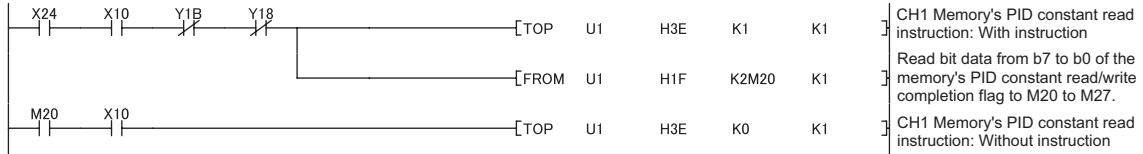

- Program that reads an error code

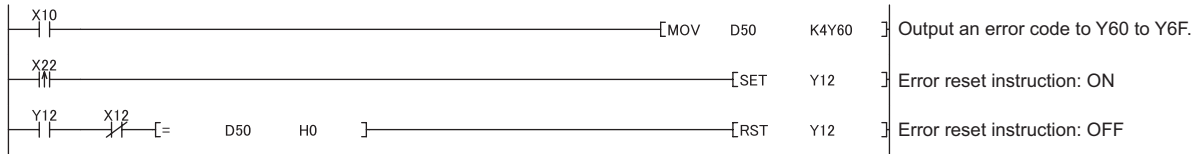

- Program that changes the set value (SV)

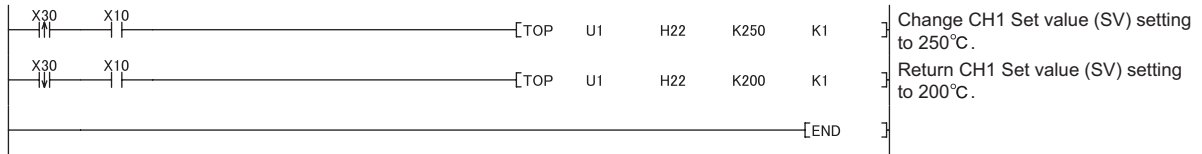

(7) Program example of when not using the parameter of an intelligent function module

(a) Devices used by a user

Device	Description	
X10	Module READY flag	L60TCTT4 (X10 to X1F)
X11	Setting/operation mode status	
X12	Error occurrence flag	
X13	Hardware error flag	
X14	CH1 Auto tuning status	
X18	Back-up of the set value completion flag	
X1B	Setting change completion flag	LX42C4 (X20 to X5F)
X20	Set value write instruction	
X21	Auto tuning execute instruction	
X22	Error code reset instruction	
X23	Operation mode setting instruction	
X24	Memory of PID constants read instruction	
X30	CH1 Set value (SV) change instruction	L60TCTT4 (Y10 to Y1F)
Y11	Setting/operation mode instruction	
Y12	Error reset instruction	
Y14	CH1 Auto tuning instruction	
Y18	Set value backup instruction	LY42NT1P (Y60 to Y9F)
Y1B	Setting change instruction	
Y60 to Y6F	Error code output	
D50	Error code	
D51	CH1 Temperature process value (PV)	
M0	For writing set value 0	
M1	For writing set value 1	
M2	For writing set value 2	
M10	CH1 Auto tuning completion flag	
M20 to M23	CH□ Read completion flag	
M24 to M27	CH□ Write completion flag	

(b) Program example

- Program that changes the setting/operation mode

This program is the same as that of when it is used as a temperature input module. (☞ Page 259, Section 10.2.1 (6) (e))

- Initial setting program

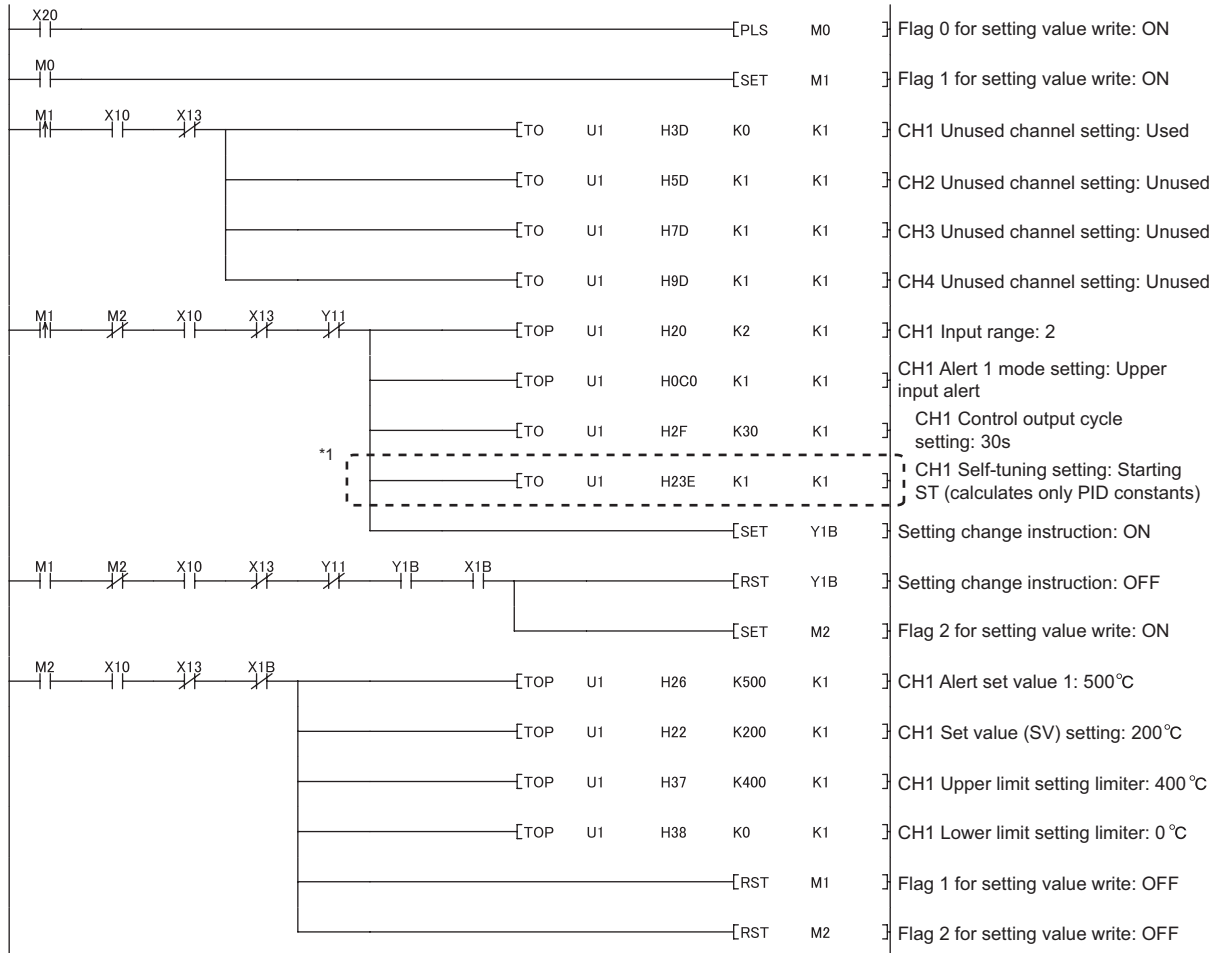

*1 Configure this setting only when the self-tuning function is used.

- Program that executes the auto tuning and backs up the PID constants in the non-volatile memory

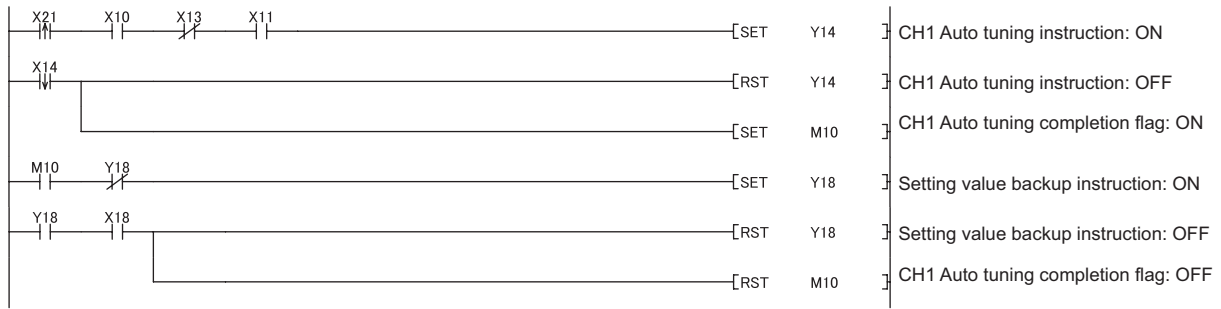

- Program that reads the PID constants from the non-volatile memory
 This program is the same as that of when the parameter of the intelligent function module is used.
 (☞ Page 270, Section 10.2.2 (6) (f))

- Program that reads an error code and the temperature process value (PV)

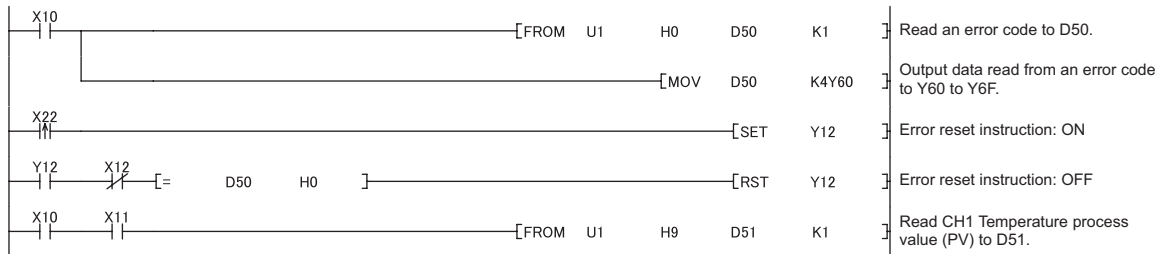

- Program that changes the set value (SV)
 This program is the same as that of when the parameter of the intelligent function module is used.
 (☞ Page 270, Section 10.2.2 (6) (f))

10.2 When Using the Module in a Standard System Configuration
 10.2.2 Standard control (such as auto tuning, self-tuning, and error code read)

10.2.3 Standard control (peak current suppression function, simultaneous temperature rise function)

This section describes the program example where the peak current suppression function and the simultaneous temperature rise function are used for the control.

(1) System configuration

The following figure shows the system configuration example of when the peak current suppression function and the simultaneous temperature rise function are used for the control.

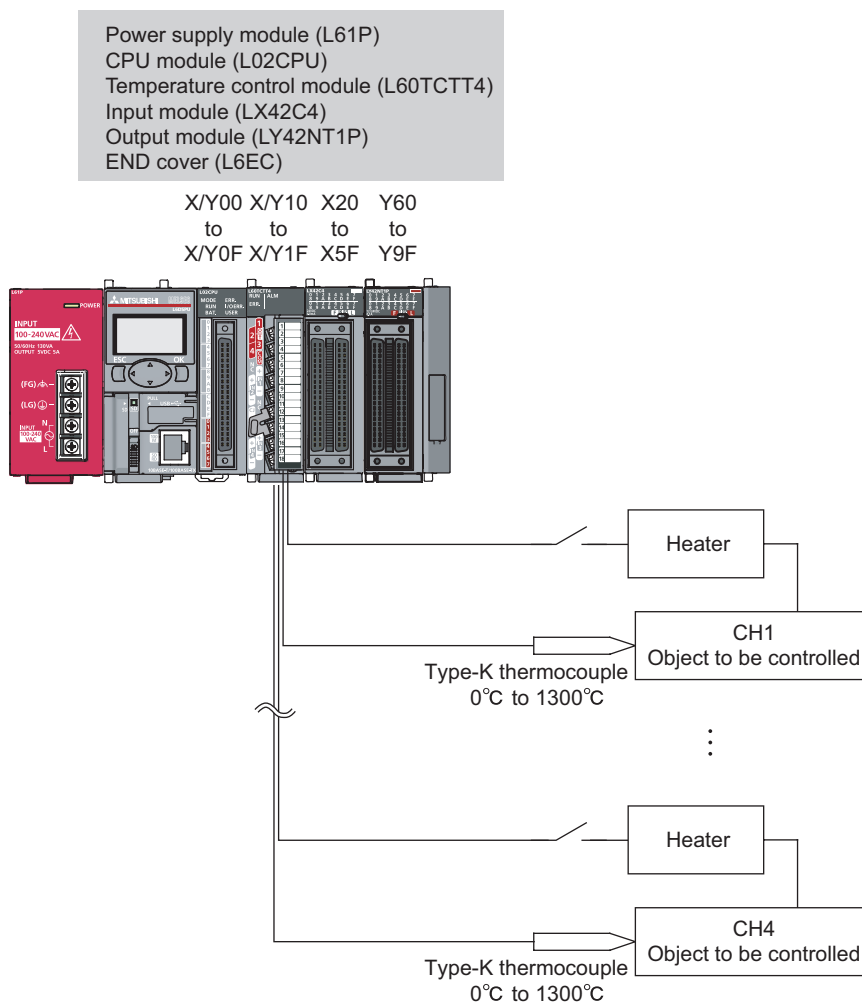

Point

- When using the L26CPU-BT, set the I/O assignment of the built-in CC-Link of the L26CPU-BT to X/YFE0 to X/YFFF so that the I/O assignment be the same as that of the system configuration above.
- When the L60TCTT4BW or the L60TCRT4BW is used, the I/O assignment is the same as that of the system configuration shown above.
 - Slot 0: 16 intelligent points
 - Slot 1: 64 input points
 - Slot 2: 64 output points

(2) Programming condition

- Program example where the peak current suppression function is used

This program is designed to suppress the peak current by automatically changing the values of the upper limit output limiter of CH1 to CH4 and dividing the timing of the transistor output into four timing.

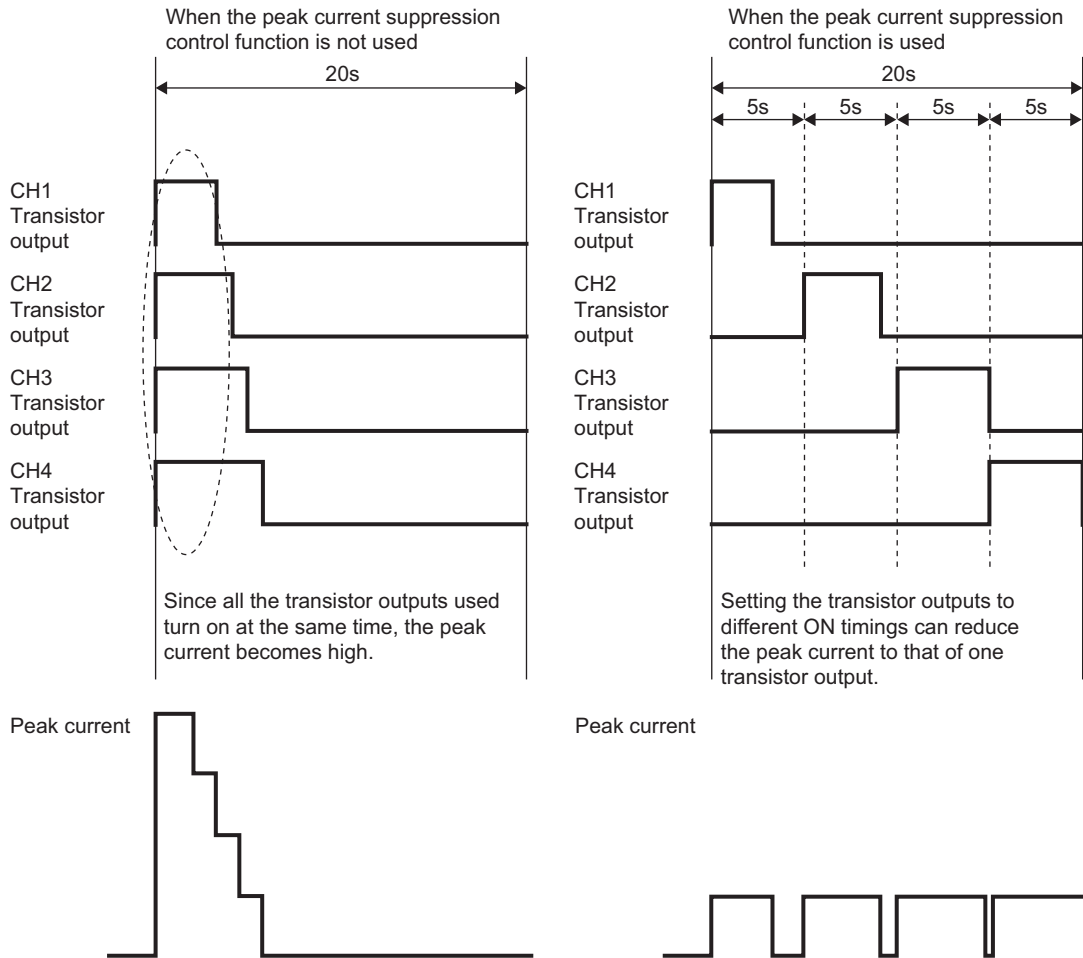

10.2 When Using the Module in a Standard System Configuration
 10.2.3 Standard control (peak current suppression function, simultaneous temperature rise function)

- Program example where the simultaneous temperature rise function is used
 This program is designed to classify the CH1 and CH2 into group 1 and CH3 and CH4 into group 2 so that the channels in each group reach the set values (SV) simultaneously.

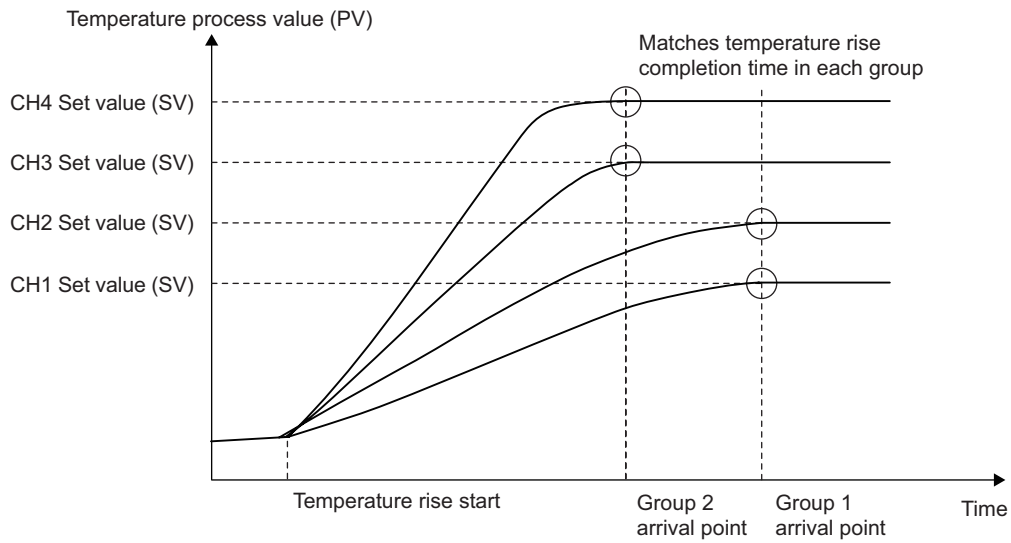

(3) Wiring example

The following figure shows a wiring example.

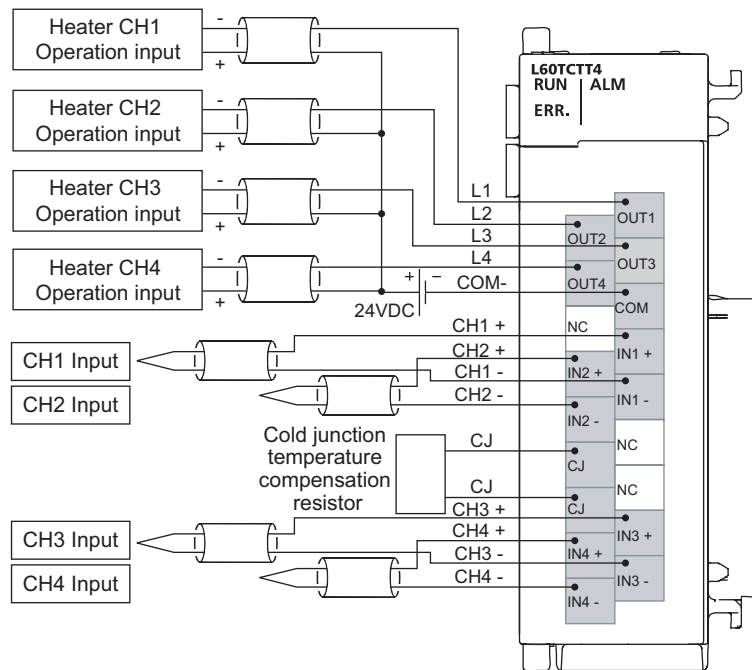

(4) Switch Setting

Configure settings such as the input mode selection and the auto-setting at the input range change as follows.

Project window ⇨ [Intelligent Function Module] ⇨ [L60TCTT4] ⇨ [Switch Setting]

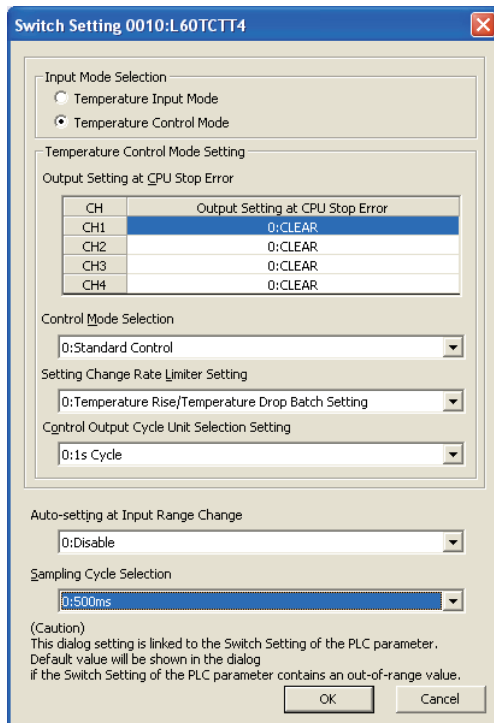

Item	Set value				
	CH1	CH2	CH3	CH4	
Input Mode Selection	Temperature Control Mode				
Temperature Control Mode Setting	Output Setting at CPU Stop Error	0: CLEAR	0: CLEAR	0: CLEAR	0: CLEAR
	Control Mode Selection	0: Standard Control			
	Setting Change Rate Limiter Setting	0: Temperature Rise/Temperature Drop Batch Setting			
	Control Output Cycle Unit Selection Setting	0: 1s Cycle			
Auto-setting at Input Range Change	0: Disable				
Sampling Cycle Selection	0: 500ms				

10.2 When Using the Module in a Standard System Configuration
10.2.3 Standard control (peak current suppression function, simultaneous temperature rise function)

(5) Contents of the initial setting

Item	Description			
	CH1	CH2	CH3	CH4
Input range	2: ThermocoupleK Measured Temperature Range (0 to 1300°C)	2: ThermocoupleK Measured Temperature Range (0 to 1300°C)	2: ThermocoupleK Measured Temperature Range (0 to 1300°C)	2: ThermocoupleK Measured Temperature Range (0 to 1300°C)
Set value (SV) setting	200°C	250°C	300°C	350°C
Unused channel setting	0: Used	0: Used	0: Used	0: Used
Control output cycle setting	20 s	20 s	20 s	20 s
Simultaneous temperature rise group setting* ¹	1: Group 1	1: Group 1	2: Group 2	2: Group 2
Peak current suppression control group setting* ²	1: Group 1	2: Group 2	3: Group 3	4: Group 4
Simultaneous temperature rise AT mode selection* ¹	1: AT for Simultaneous Temperature Rise	1: AT for Simultaneous Temperature Rise	1: AT for Simultaneous Temperature Rise	1: AT for Simultaneous Temperature Rise

*1 Configure this setting only when the simultaneous temperature rise function is used.

*2 Configure this setting only when the peak current suppression function is used.

(6) When using the parameter of an intelligent function module

(a) Devices used by a user

Device	Description
X10	Module READY flag
X12	Error occurrence flag
X22	Error code reset instruction
X23	Operation mode setting instruction
X24	Memory of PID constants read instruction
Y11	Setting/operation mode instruction
Y12	Error reset instruction
Y18	Set value backup instruction
Y1B	Setting change instruction
Y60 to Y6F	Error code output
D50	Error code
D51 to D54	CH□ Temperature process value (PV)
M20 to M23	CH□ Read completion flag
M24 to M27	CH□ Write completion flag

(b) Parameter setting

Set the contents of initial settings in the parameter.

1. Open the "Parameter" window.

Project window ⇨ [Intelligent Function Module] ⇨ [L60TCTT4] ⇨ [Parameter]

2. Click Clear Value for Gray Cells to set items unnecessary for the mode set on Switch Setting to 0.

3. Set the parameter.

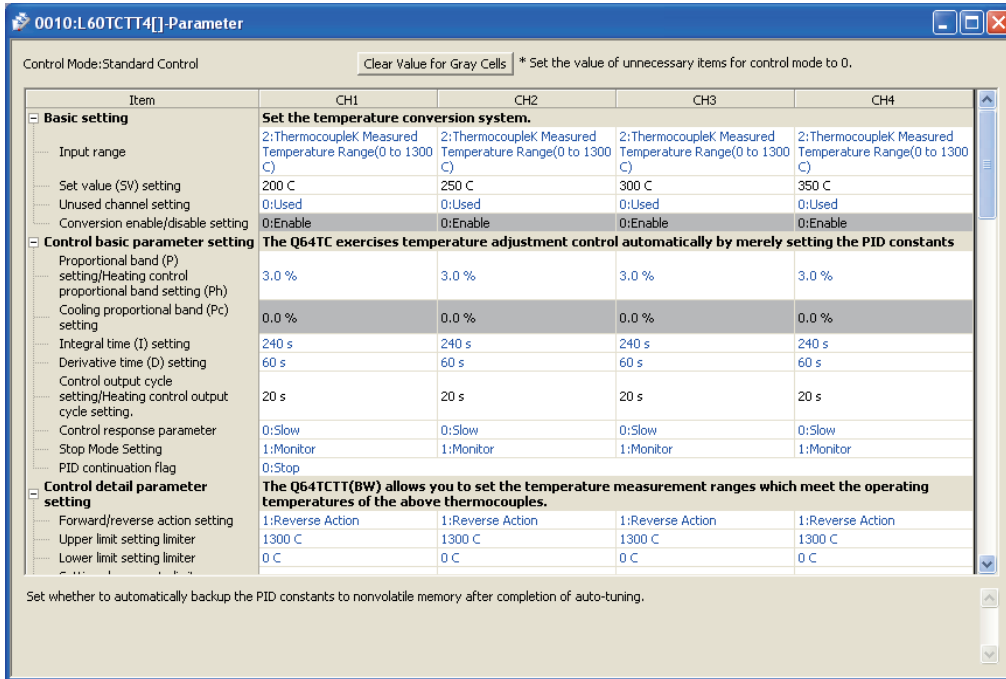

Item	Description	Setting value			
		CH1	CH2	CH3	CH4
Input range	Set the temperature sensor used for the L60TC4 and the measurement range.	2: ThermocoupleK Measured Temperature Range (0 to 1300°C)	2: ThermocoupleK Measured Temperature Range (0 to 1300°C)	2: ThermocoupleK Measured Temperature Range (0 to 1300°C)	2: ThermocoupleK Measured Temperature Range (0 to 1300°C)
Set value (SV) setting	Set the target temperature value of PID control.	200°C	250°C	300°C	350°C
Unused channel setting	Configure this setting when the channels where the temperature control is not performed and the temperature sensor is not connected are set to be unused.	0: Used	0: Used	0: Used	0: Used
Control output cycle setting/Heating control output cycle setting	Set the pulse cycle (ON/OFF cycle) of the transistor output.	20 s	20 s	20 s	20 s
Simultaneous temperature rise group setting ^{*1}	Set the group to perform the simultaneous temperature rise function for each channel.	1: Group 1	1: Group 1	2: Group 2	2: Group 2

10.2 When Using the Module in a Standard System Configuration
10.2.3 Standard control (peak current suppression function, simultaneous temperature rise function)

Item	Description	Setting value			
		CH1	CH2	CH3	CH4
Peak current suppression control group setting ^{*2}	Set the target channels for the peak current suppression function and the gap of the control output cycles between channels.	1: Group 1	2: Group 2	3: Group 3	4: Group 4
Simultaneous temperature rise AT mode selection ^{*1}	Set the mode of the auto tuning.	1: AT for Simultaneous Temperature Rise	1: AT for Simultaneous Temperature Rise	1: AT for Simultaneous Temperature Rise	1: AT for Simultaneous Temperature Rise

*1 Configure this setting only when the simultaneous temperature rise function is used.

*2 Configure this setting only when the peak current suppression function is used.

(c) Auto refresh setting

Set the device to be automatically refreshed.

Project window ⇨ [Intelligent Function Module] ⇨ [L60TCTT4] ⇨ [Auto_Refresh]

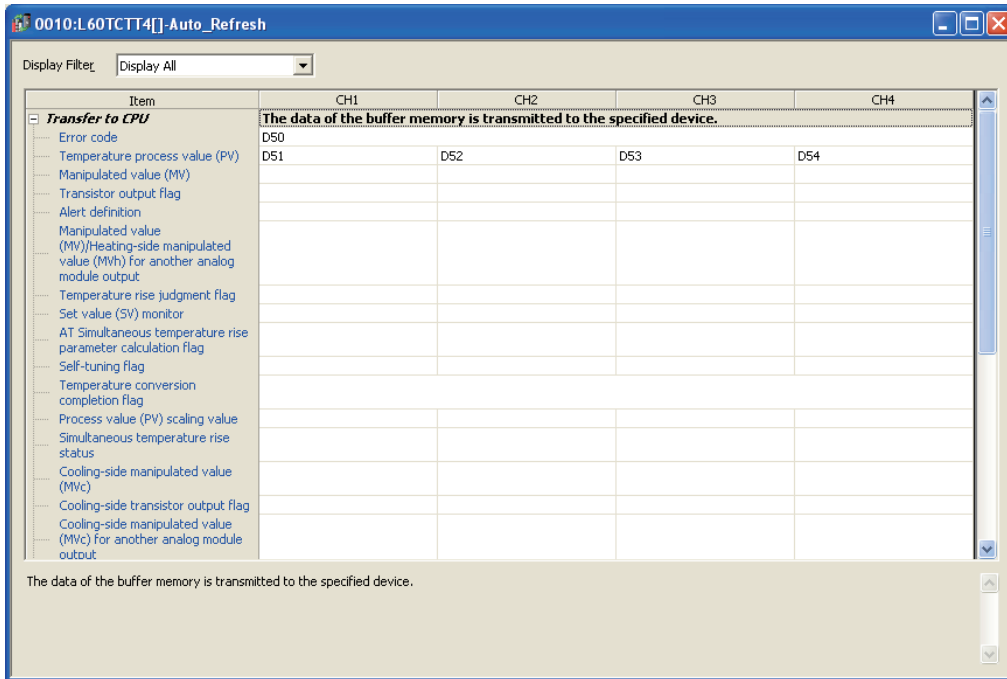

Item	Description	Setting value			
		CH1	CH2	CH3	CH4
Error code	An error code or alarm code is stored.	D50			
Temperature process value (PV)	The detected temperature value where sensor correction was performed is stored.	D51	D52	D53	D54

(d) Writing parameter of an intelligent function module

Write the set parameter to the CPU module. Then reset the CPU module or turn off and on the power supply of the programmable controller.

[Online] ⇨ [Write to PLC...]

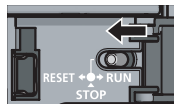

or Power OFF → ON

10.2 When Using the Module in a Standard System Configuration
10.2.3 Standard control (peak current suppression function, simultaneous temperature rise function)

(e) Performing auto tuning

Set the "Automatic backup setting after auto tuning of PID constants" to "ON" and perform the auto tuning.

☞ [Tool] ⇨ [Intelligent Function Module Tool] ⇨ [Temperature Control Module]
 ⇨ [Auto Tuning...] ⇨ [L60TCTT4] ⇨

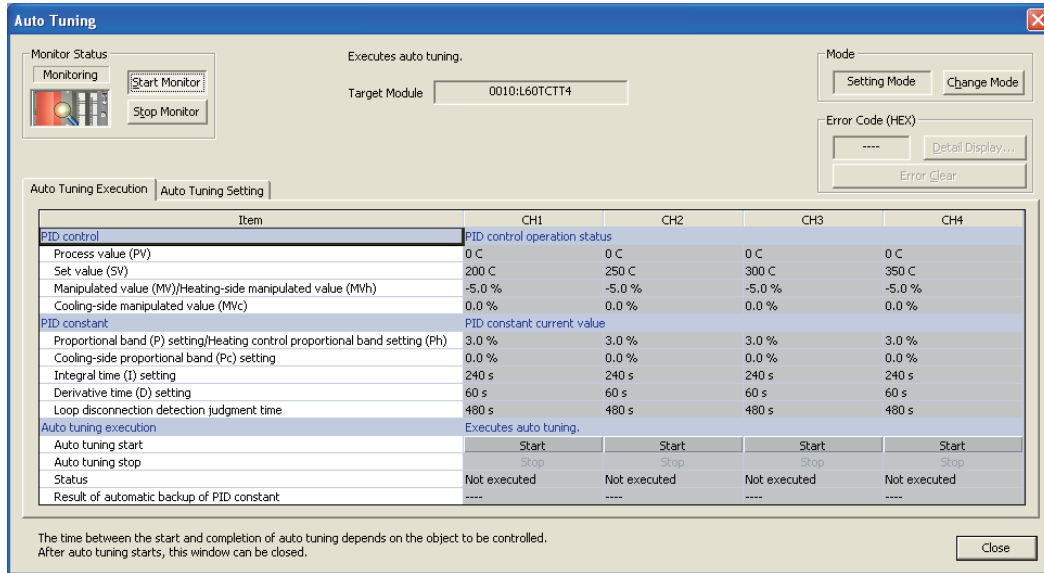

(f) Program example where the peak current suppression function or the simultaneous temperature rise function is used

- Program that changes the setting/operation mode

This program is the same as that of when it is used as a temperature input module. (☞ Page 259, Section 10.2.1 (6) (e))

- Program that reads the PID constants from the non-volatile memory

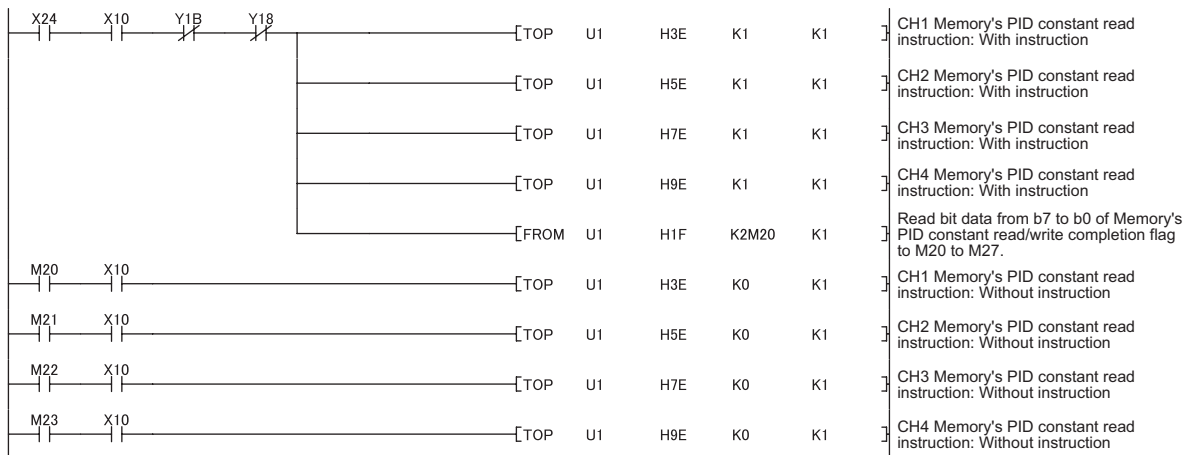

- Program that reads an error code

This program is the same as that of when it is used as a temperature input module. (☞ Page 259, Section 10.2.1 (6) (e))

(7) Program example of when not using the parameter of an intelligent function module

(a) Devices used by a user

Device	Description	
X10	Module READY flag	L60TCTT4 (X10 to X1F)
X11	Setting/operation mode status	
X12	Error occurrence flag	
X13	Hardware error flag	
X14 to X17	CH□ Auto tuning status	
X18	Back-up of the set value completion flag	
X1B	Setting change completion flag	
X20	Set value write instruction	LX42C4 (X20 to X5F)
X21	Auto tuning execute instruction	
X22	Error code reset instruction	
X23	Operation mode setting instruction	
X24	Memory of PID constants read instruction	
Y11	Setting/operation mode instruction	L60TCTT4 (Y10 to Y1F)
Y12	Error reset instruction	
Y14 to Y17	CH□ Auto tuning instruction	
Y18	Set value backup instruction	
Y1B	Setting change instruction	
Y60 to Y6F	Error code output	LY42NT1P (Y60 to Y9F)
D50	Error code	
D51 to D54	CH□ Temperature process value (PV)	
M0	For writing set value 0	
M1	For writing set value 1	
M2	For writing set value 2	
M10 to M13	CH□ Auto tuning completion flag	
M20 to M23	CH□ Read completion flag	
M24 to M27	CH□ Write completion flag	

(b) Program example where the peak current suppression function is used

- Program that changes the setting/operation mode

This is the same as that of when it is used as a temperature input module. (☞ Page 259, Section 10.2.1 (6) (e))

- Initial setting program

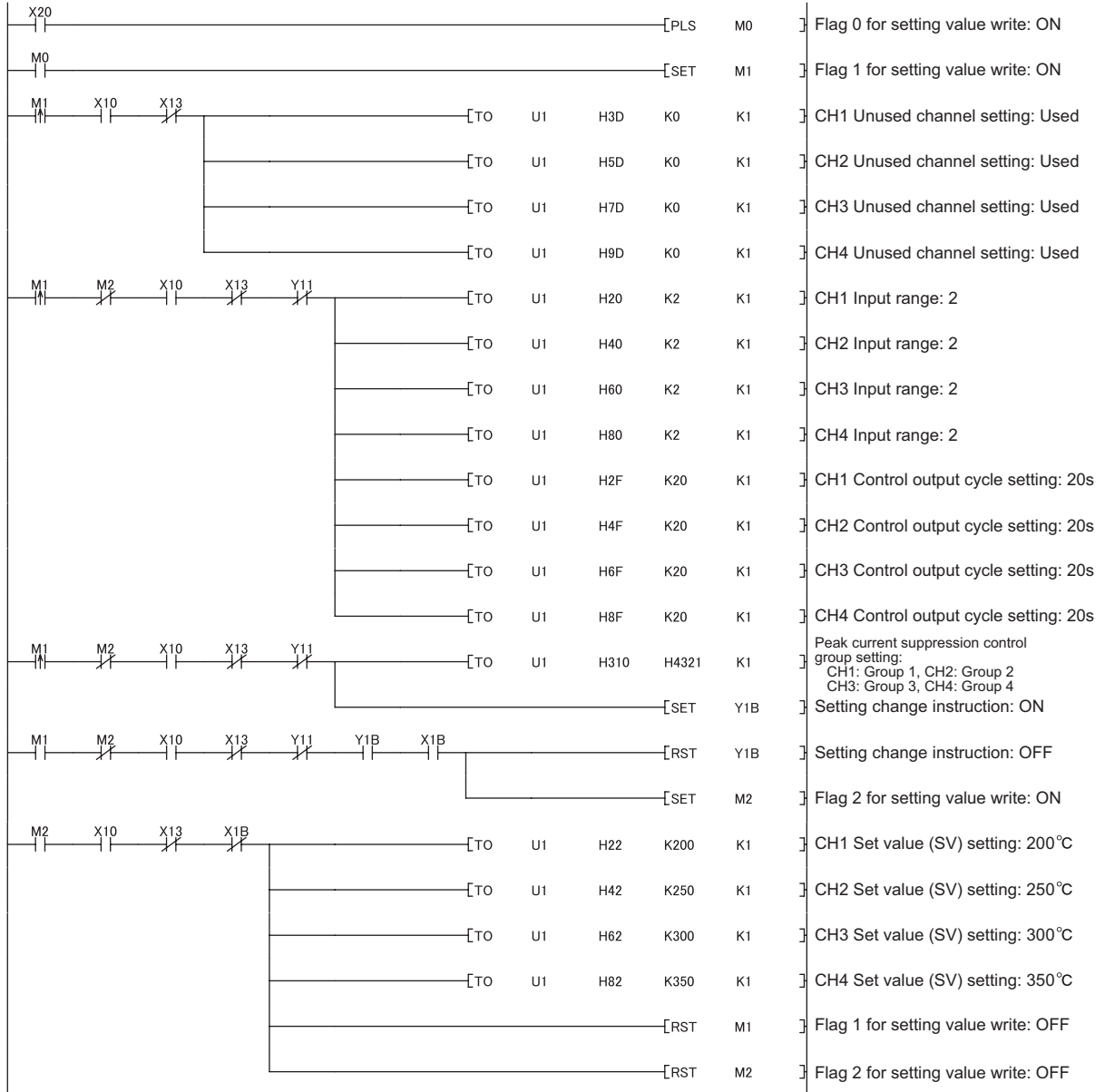

- Program that executes the auto tuning and backs up the PID constants in the non-volatile memory

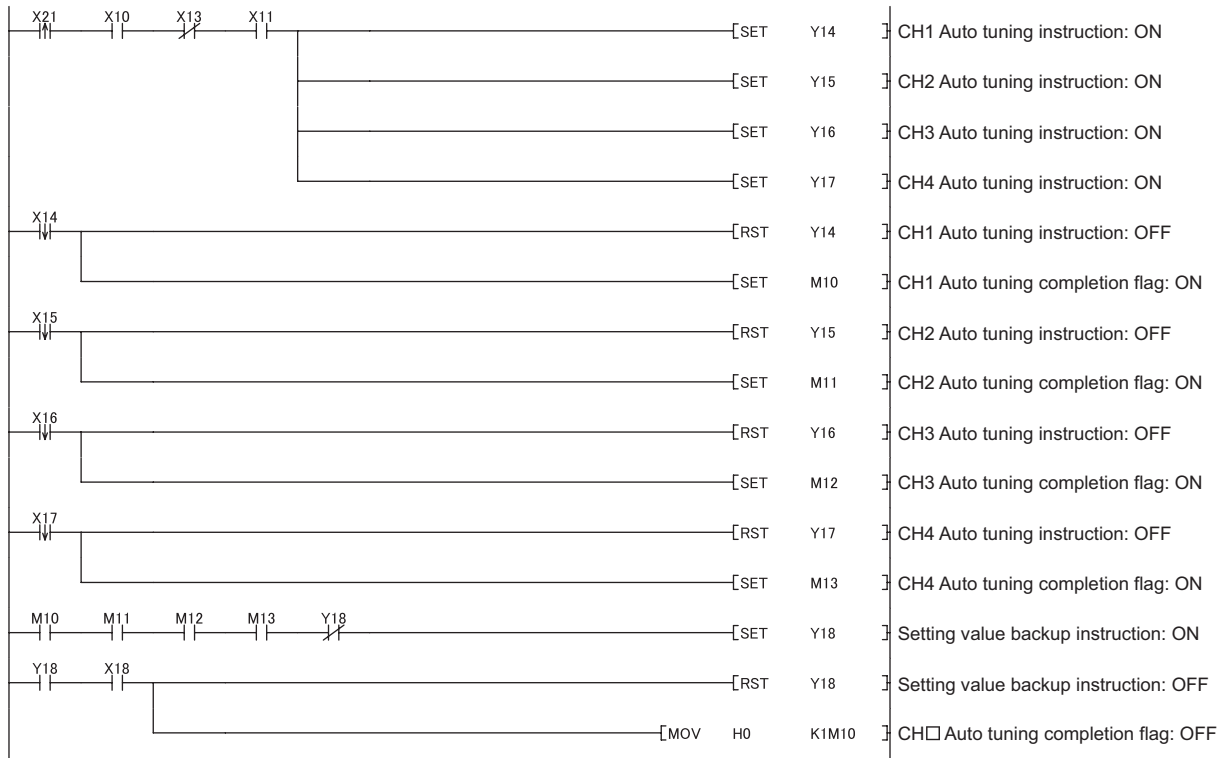

- Program that reads the PID constants from the non-volatile memory
This program is the same as that of when the parameter of the intelligent function module is used.
(☞ Page 282, Section 10.2.3 (6) (f))

- Program that reads an error code and the temperature process value (PV)

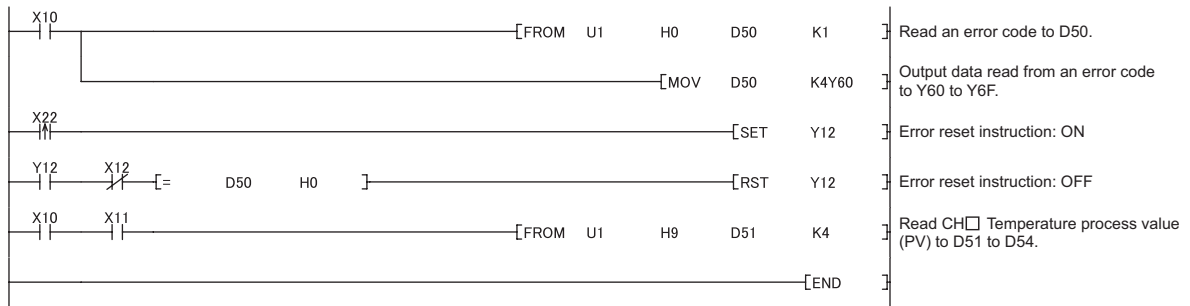

10.2 When Using the Module in a Standard System Configuration
10.2.3 Standard control (peak current suppression function, simultaneous temperature rise function)

(c) Program example where the simultaneous temperature rise function is used

- Program that changes the setting/operation mode

This program is the same as that of when it is used as a temperature input module. (☞ Page 259, Section 10.2.1 (6) (e))

- Initial setting program

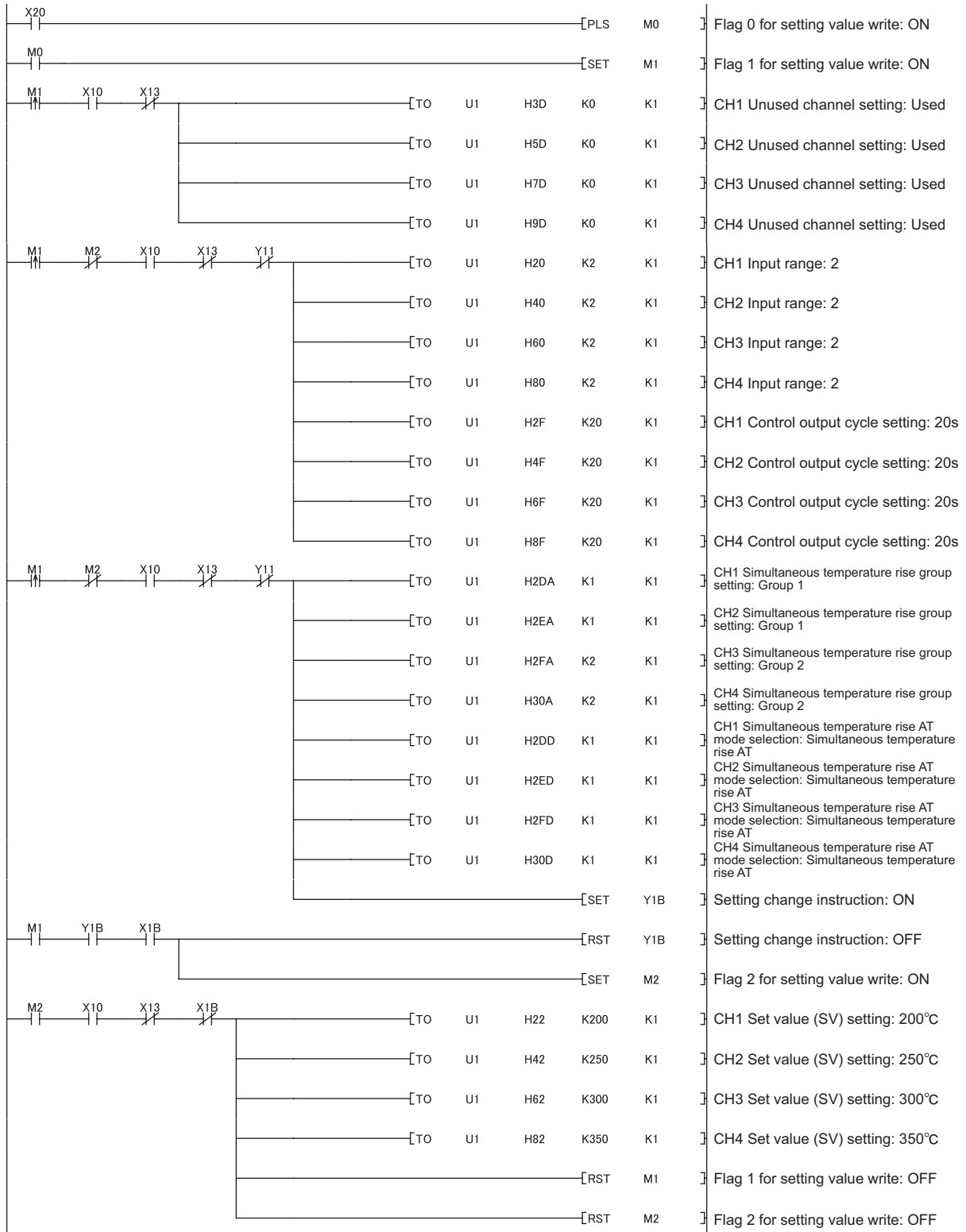

- Program that executes the auto tuning and backs up the PID constants in the non-volatile memory
This program is the same as that of when the peak current suppression function is used. (☞ Page 284, Section 10.2.3 (7) (b))
- Program that reads the PID constants from the non-volatile memory
This program is the same as that of when the parameter of the intelligent function module is used.
(☞ Page 282, Section 10.2.3 (6) (f))
- Program that reads an error code
This program is the same as that of when the peak current suppression function is used. (☞ Page 284, Section 10.2.3 (7) (b))

10.2.4 When performing the heating-cooling control

This section describes the program example to perform the heating-cooling control.

(1) System configuration

The following figure shows the system configuration example to perform the heating-cooling control.

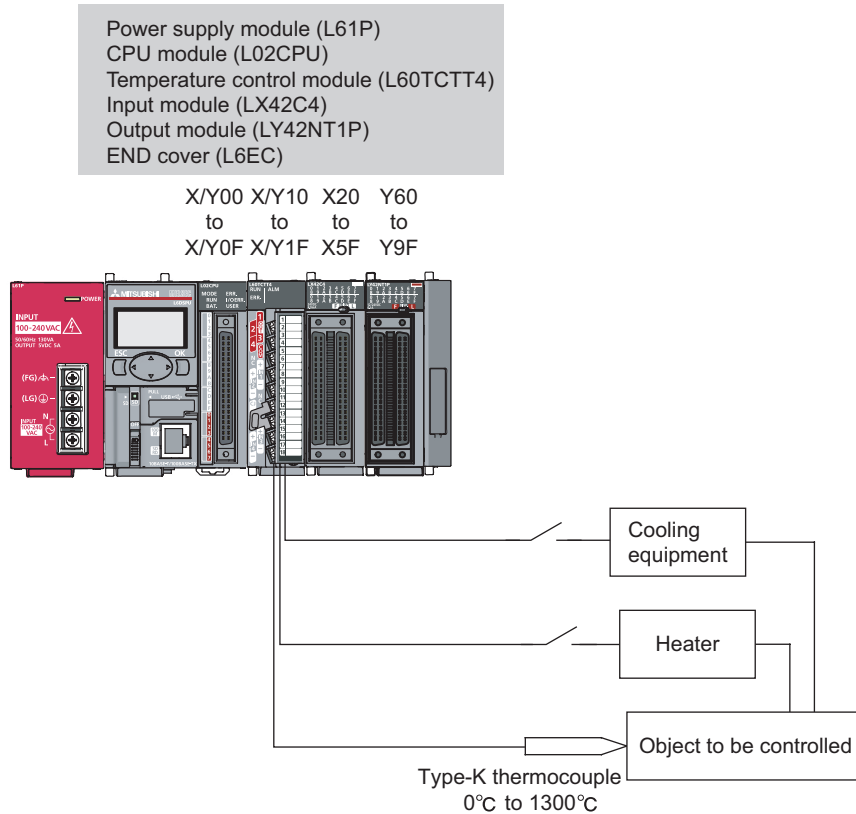

Point

- When using the L26CPU-BT, set the I/O assignment of the built-in CC-Link of the L26CPU-BT to X/YFE0 to X/YFFF so that the I/O assignment be the same as that of the system configuration above.
- When the L60TCTT4BW or the L60TCRT4BW is used, the I/O assignment is the same as that of the system configuration shown above.
 - Slot 0: 16 intelligent points
 - Slot 1: 64 input points
 - Slot 2: 64 output points

(2) Program conditions

This program is designed to perform the heating-cooling control by using the temperature input of CH1.

(3) Wiring example

The following figure shows a wiring example.

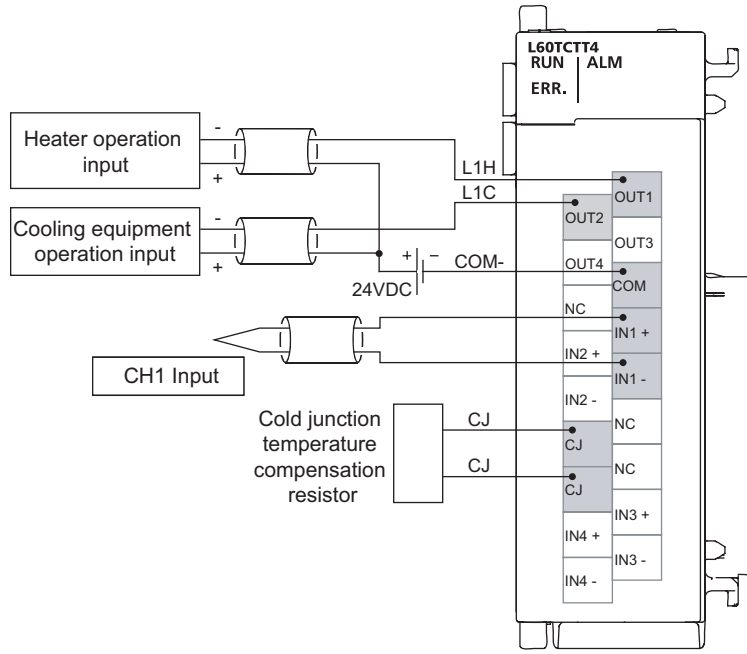

10.2 When Using the Module in a Standard System Configuration
 10.2.4 When performing the heating-cooling control

(4) Switch Setting

Configure settings such as the input mode selection and the auto-setting at input range change as follows.

Project window ⇨ [Intelligent Function Module] ⇨ [L60TCTT4] ⇨ [Switch Setting]

Item		Setting value			
		CH1	CH2	CH3	CH4
Input Mode Selection		Temperature Control Mode			
Temperature Control Mode Setting	Output Setting at CPU Stop Error	0: CLEAR	0: CLEAR	0: CLEAR	0: CLEAR
	Control Mode Selection	3: Mix Control (Normal Mode)			
	Setting Change Rate Limiter Setting	0: Temperature Rise/Temperature Drop Batch Setting			
	Control Output Cycle Unit Selection Setting	0: 1s Cycle			
Auto-setting at Input Range Change		0: Disable			
Sampling Cycle Selection		0: 500ms			

(5) Contents of the initial setting

Item	Description			
	CH1	CH2	CH3	CH4
Input range	2: ThermocoupleK Measured Temperature Range (0 to 1300°C)	2: ThermocoupleK Measured Temperature Range (0 to 1300°C)	2: ThermocoupleK Measured Temperature Range (0 to 1300°C)	2: ThermocoupleK Measured Temperature Range (0 to 1300°C)
Set value (SV) setting	200°C	0°C	0°C	0°C
Unused channel setting	0: Used	0: Used	1: Unused	1: Unused
Heating control output cycle setting	30 s	0 s	30 s	30 s
Cooling method setting	0: Air Cooled	0: Air Cooled	0: Air Cooled	0: Air Cooled
Cooling control output cycle setting	30 s	0 s	30 s	30 s
Overlap/Dead band setting	-0.3 %	0.0 %	0.0 %	0.0 %

(6) When using the parameter of an intelligent function module**(a) Devices used by a user**

Device	Description	
X10	Module READY flag	L60TCTT4 (X10 to X1F)
X12	Error occurrence flag	
X22	Error code reset instruction	LX42C4 (X20 to X5F)
X23	Operation mode setting instruction	
X24	Memory of PID constants read instruction	
Y11	Setting/operation mode instruction	L60TCTT4 (Y10 to Y1F)
Y12	Error reset instruction	
Y18	Set value backup instruction	
Y1B	Setting change instruction	
Y60 to Y6F	Error code output	LY42NT1P (Y60 to Y9F)
D50	Error code	Devices where data is written by auto refresh
D51	CH1 Temperature process value (PV)	
M20 to M23	CH□ Read completion flag	
M24 to M27	CH□ Write completion flag	

(b) Parameter setting

Set the contents of initial settings in the parameter.

1. Open the "Parameter" window.

Project window ⇨ [Intelligent Function Module] ⇨ [L60TCTT4] ⇨ [Parameter]

2. Click **Clear Value for Gray Cells** to set items unnecessary for the mode set on Switch Setting to 0.

3. Set the parameter.

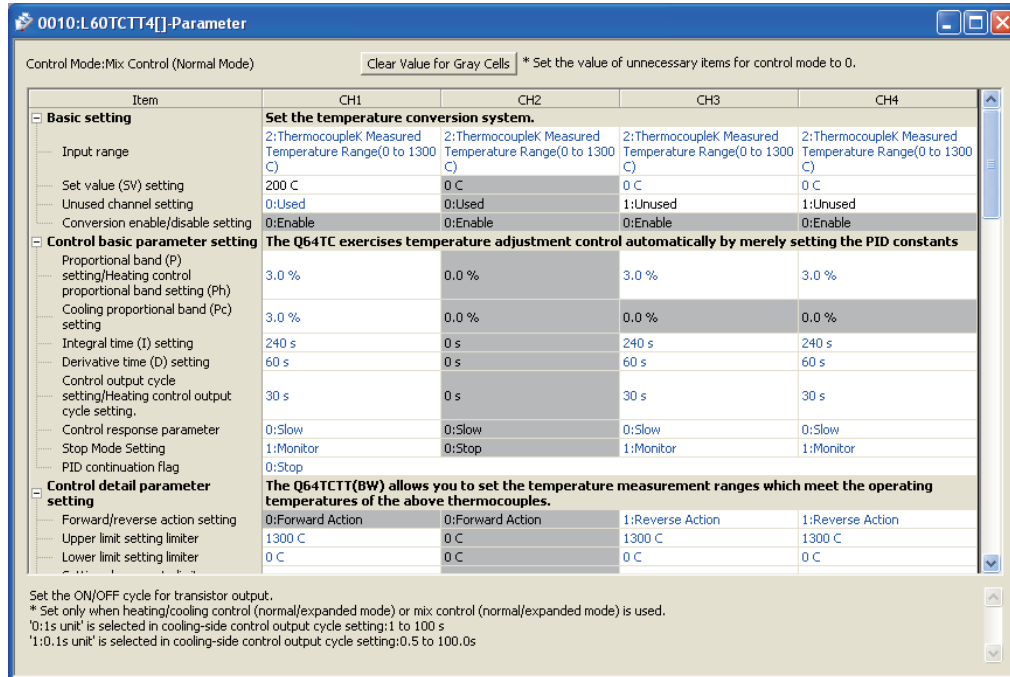

Item	Description	Setting value			
		CH1	CH2	CH3	CH4
Input range	Set the temperature sensor used for the L60TC4 and the measurement range.	2: ThermocoupleK Measured Temperature Range (0 to 1300°C)	2: ThermocoupleK Measured Temperature Range (0 to 1300°C)	2: ThermocoupleK Measured Temperature Range (0 to 1300°C)	2: ThermocoupleK Measured Temperature Range (0 to 1300°C)
Set value (SV) setting	Set the target temperature value of PID control.	200°C	0°C	0°C	0°C
Unused channel setting	Configure this setting when the channels where the temperature control is not performed and the temperature sensor is not connected are set to be unused.	0: Used	0: Used	1: Unused	1: Unused
Control output cycle setting/Heating control output cycle setting	Set the pulse cycle (ON/OFF cycle) of the transistor output.	30 s	0 s	30 s	30 s
Cooling method setting	Set the method for the cooling control in the heating-cooling control.	0: Air Cooled	0: Air Cooled	0: Air Cooled	0: Air Cooled

Item	Description	Setting value			
		CH1	CH2	CH3	CH4
Cooling control output cycle setting	Set the pulse cycle (ON/OFF cycle) of the transistor output.	30 s	0 s	30 s	30 s
Overlap/dead band setting	Configure the overlap/dead band setting.	-0.3 %	0.0 %	0.0 %	0.0 %

(c) Auto refresh setting

Set the device to be automatically refreshed.

Project window ⇒ [Intelligent Function Module] ⇒ [L60TCTT4] ⇒ [Auto_Refresh]

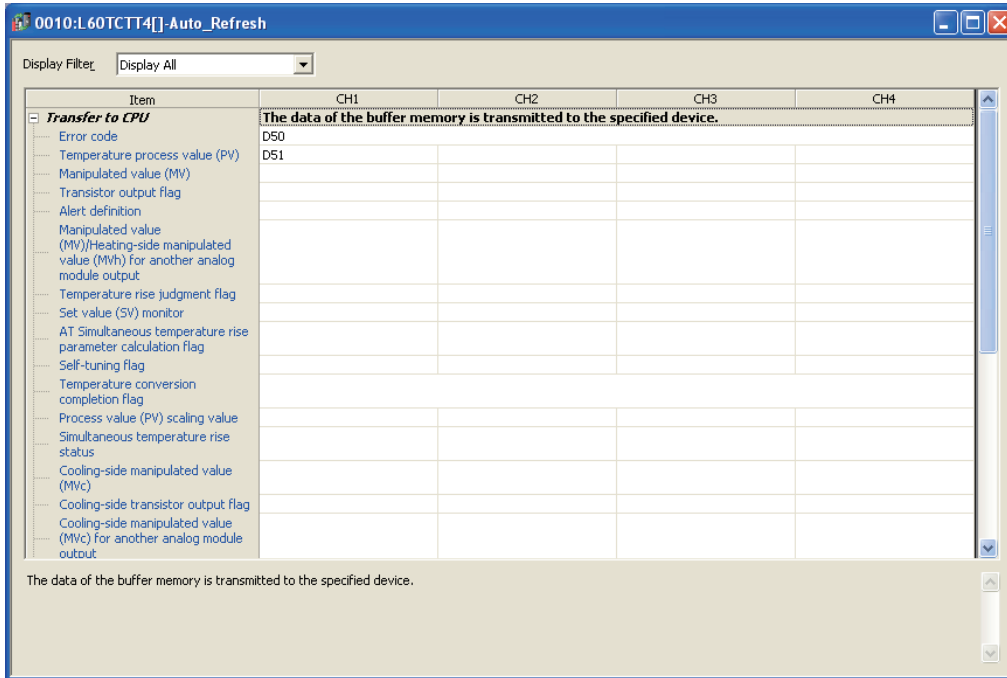

Item	Description	Setting value			
		CH1	CH2	CH3	CH4
Error code	An error code or alarm code is stored.	D50			
Temperature process value (PV)	The detected temperature value where sensor correction is performed is stored.	D51	—	—	—

(d) Writing parameter of an intelligent function module

Write the set parameter to the CPU module. Then reset the CPU module or turn off and on the power supply of the programmable controller.

[Online] ⇒ [Write to PLC...]

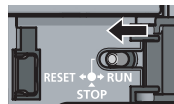

or Power OFF → ON

(e) Performing auto tuning

Set the "Automatic backup setting after auto tuning of PID constants" to "ON" and perform the auto tuning.

[Tool] ⇒ [Intelligent Function Module Tool] ⇒ [Temperature Control Module]
 ⇒ [Auto Tuning...] ⇒ "L60TCTT4" ⇒

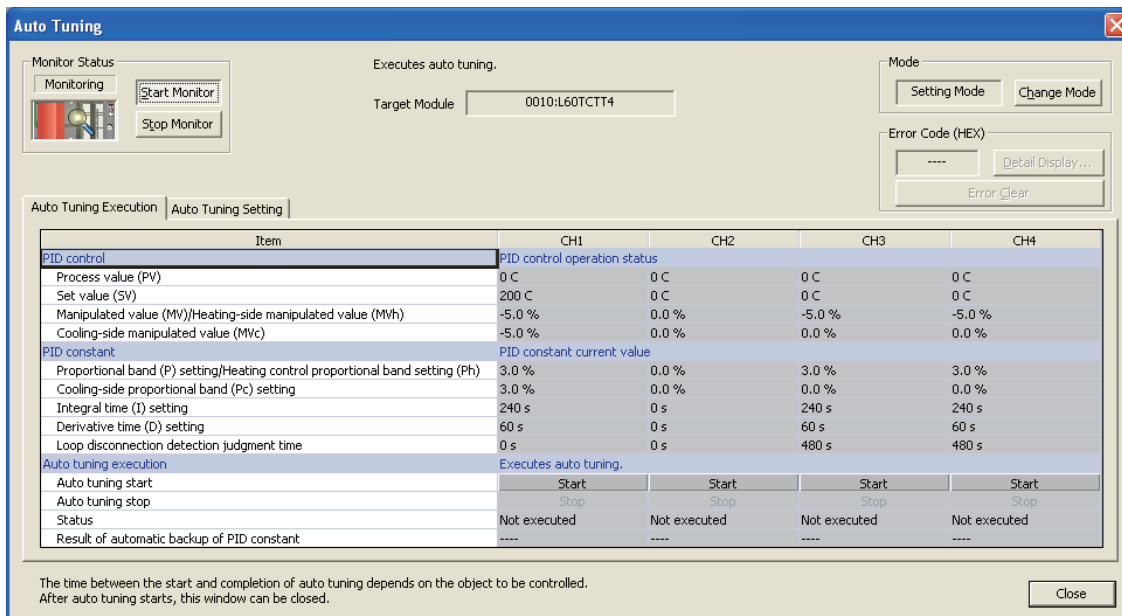
**(f) Program example**

- Program that changes the setting/operation mode

This program is the same as that of when it is used as a temperature input module. (Page 259, Section 10.2.1 (6) (e))

- Program that reads the PID constants from the non-volatile memory

This program is used when the module is in the standard control (such as auto tuning, self-tuning, and error code read). (Page 270, Section 10.2.2 (6) (f))

- Program that reads an error code

This program is the same as that of when it is used as a temperature input module. (Page 259, Section 10.2.1 (6) (e))

(7) Program example of when not using the parameter of an intelligent function module

(a) Devices used by a user

Device	Description	
X10	Module READY flag	L60TCTT4 (X10 to X1F)
X11	Setting/operation mode status	
X12	Error occurrence flag	
X13	Hardware error flag	
X14	CH1 Auto tuning status	
X18	Back-up of the set value completion flag	
X1B	Setting change completion flag	
X20	Set value write instruction	LX42C4 (X20 to X5F)
X21	Auto tuning execute instruction	
X22	Error code reset instruction	
X23	Operation mode setting instruction	
X24	Memory of PID constants read instruction	
Y11	Setting/operation mode instruction	L60TCTT4 (Y10 to Y1F)
Y12	Error reset instruction	
Y14	CH1 Auto tuning instruction	
Y18	Set value backup instruction	
Y1B	Setting change instruction	
Y60 to Y6F	Error code output	LY42NT1P (Y60 to Y9F)
D50	Error code	
D51	CH1 Temperature process value (PV)	
M0	For writing set value 0	
M1	For writing set value 1	
M2	For writing set value 2	
M10	CH1 Auto tuning completion flag	
M20 to M23	CH□ Read completion flag	
M24 to M27	CH□ Write completion flag	

(b) Program example

- Program that changes the setting/operation mode

This program is the same as that of when it is used as a temperature input module. (☞ Page 259, Section 10.2.1 (6) (e))

- Initial setting program

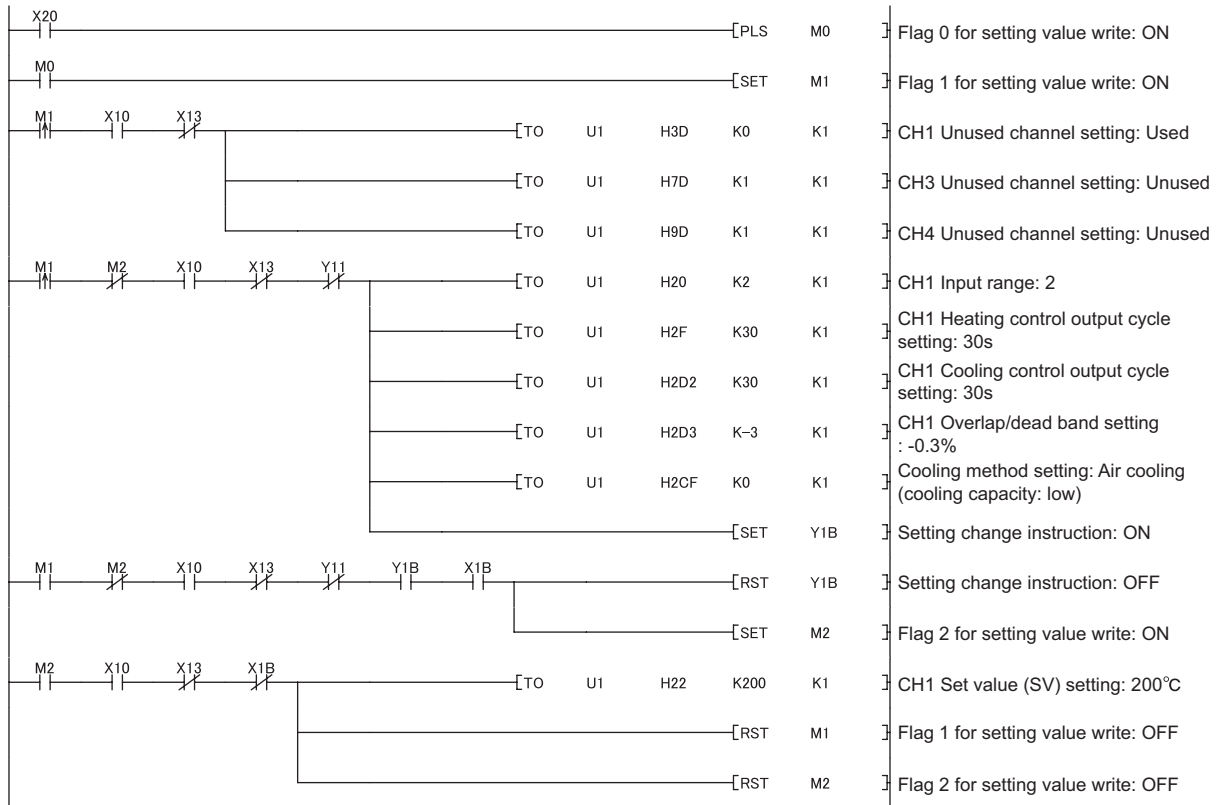

- Program that executes the auto tuning and backs up the PID constants in the non-volatile memory

This program is used when the module is in the standard control (such as auto tuning, self-tuning, and error code read). (☞ Page 272, Section 10.2.2 (7) (b))

- Program that reads the PID constants from the non-volatile memory

This program is used when the module is in the standard control (such as auto tuning, self-tuning, and error code read). (☞ Page 270, Section 10.2.2 (6) (f))

- Program that reads an error code

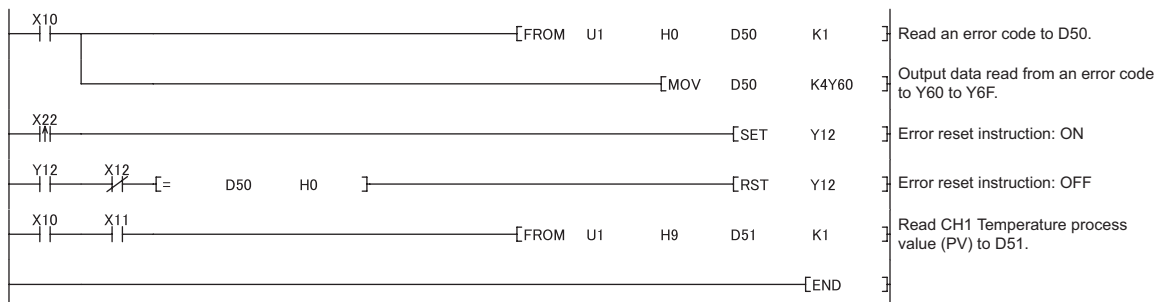

10.2 When Using the Module in a Standard System Configuration
10.2.4 When performing the heating-cooling control

10.3 When the Module is Connected to the Head Module

This section describes the program example of when the module is connected to the head module.

(1) System configuration

The following figure shows the system configuration example of when the module is connected to the head module.

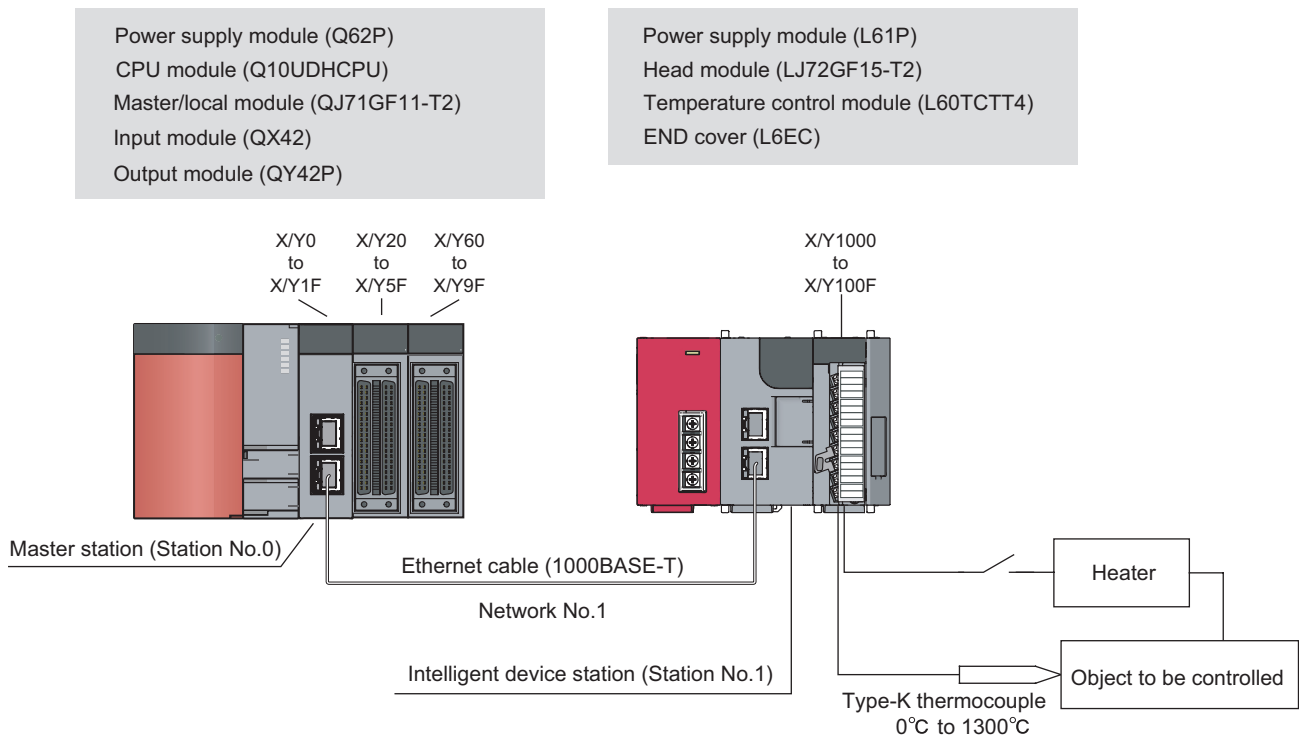

When the L60TCTT4BW or the L60TCRT4BW is used, the I/O assignment is the same as that of the system configuration shown above.

- Slot 0: 16 intelligent points
- Slot 1: 64 input points
- Slot 2: 64 output points

(2) Programming condition

This program is designed to read the temperatures measured by the thermocouple (K type, 0 to 1300°C) connected to CH1.

An error code can be read and reset.

(3) Wiring example

The wiring is the same as that of when the module is in the standard control (such as auto tuning, self-tuning, and error code read). (☞ Page 264, Section 10.2.2 (3))

(4) Switch Setting

Configure settings on the intelligent device station. (☞ Page 302, Section 10.3 (7))

(5) Contents of the initial setting

Item	Description			
	CH1	CH2	CH3	CH4
Input range	2: ThermocoupleK Measured Temperature Range (0 to 1300°C)	2: ThermocoupleK Measured Temperature Range (0 to 1300°C)	2: ThermocoupleK Measured Temperature Range (0 to 1300°C)	2: ThermocoupleK Measured Temperature Range (0 to 1300°C)
Set value (SV) setting	200°C	0°C	0°C	0°C
Unused channel setting	0: Used	1: Unused	1: Unused	1: Unused
Upper limit setting limiter	400°C	1300°C	1300°C	1300°C
Lower limit setting limiter	0°C	0°C	0°C	0°C
Alert 1 mode setting	1: Upper Limit Input Alert	0: Not Warning	0: Not Warning	0: Not Warning
Alert set value 1	500°C	0°C	0°C	0°C

(6) Setting on the master station

1. Create a project on GX Works2.

Select "QCPU (Q mode)" for "PLC Series:" and select the CPU module to be used for "PLC Type:".

☞ [Project] ⇒ [New...]

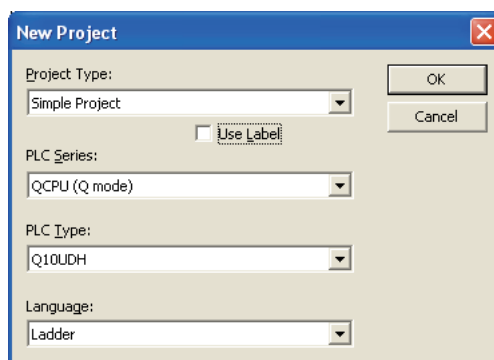

2. Display the network parameter setting window and configure the setting as follows.

- Project window ⇒ [Parameter] ⇒ [Network Parameter]
- ⇒ [Ethernet/CC IE/MELSECNET]

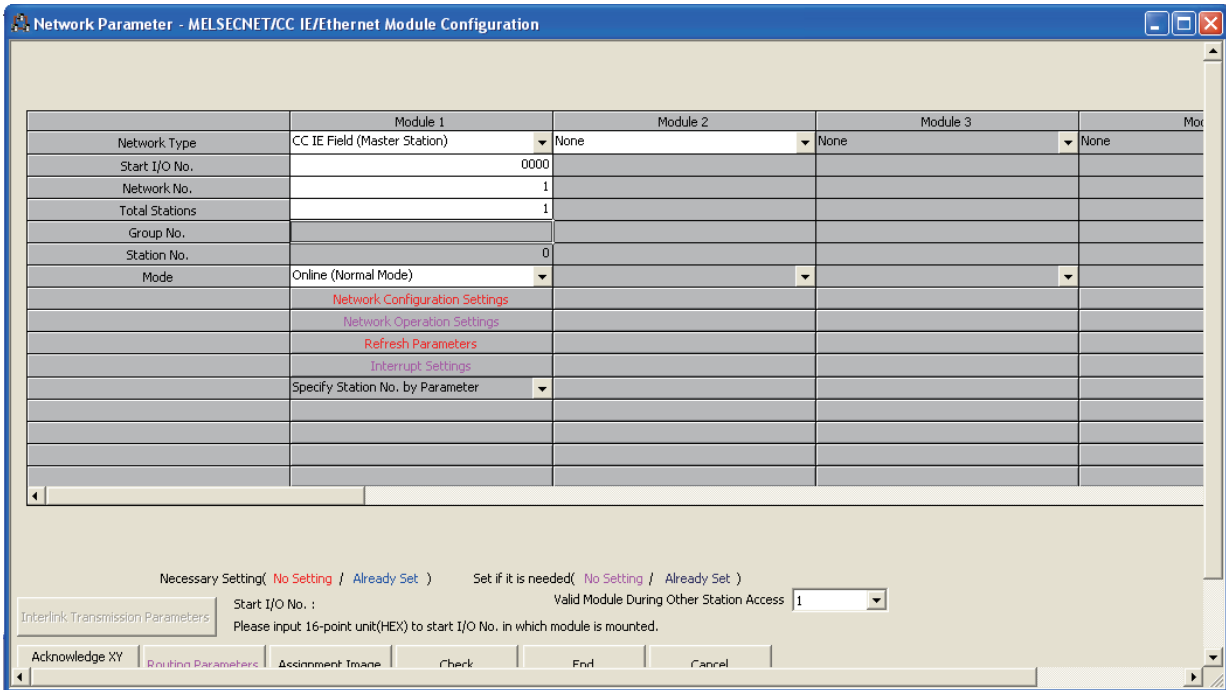

3. Display the network range assignment setting window and configure the setting as follows.

- Project window ⇒ [Parameter] ⇒ [Network Parameter]
- ⇒ [Ethernet/CC IE/MELSECNET] ⇒ **Network Configuration Settings**

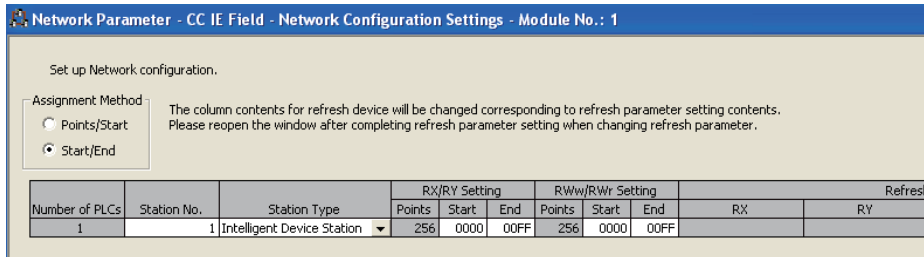

4. Display the refresh parameter setting window and configure the setting as follows.

- ☞ Project window ☞ [Parameter] ☞ [Network Parameter]
- ☞ [Ethernet/CC IE/MELSECNET] ☞ Refresh Parameters

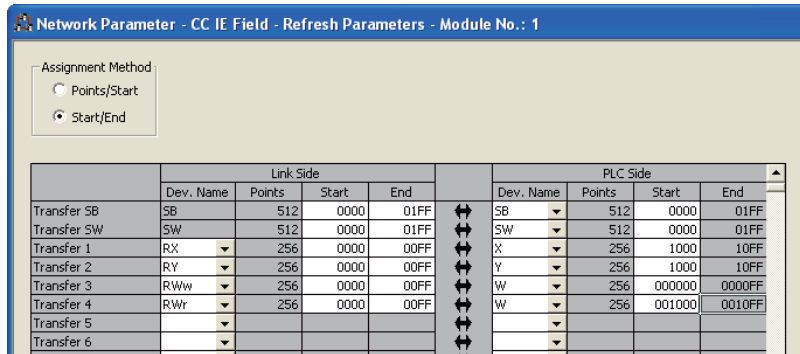

5. Write the set parameter to the CPU module on the master station. Then reset the CPU module or turn off and on the power supply of the programmable controller.

- ☞ [Online] ☞ [Write to PLC...]

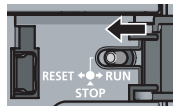

or Power OFF → ON

10.3 When the Module is Connected to the Head Module

(7) Setting on the intelligent device station

1. Create a project on GX Works2.

Select "LCPU" for "PLC Series:" and select "LJ72GF15-T2" for "PLC Type:".

 [Project] ⇨ [New...]

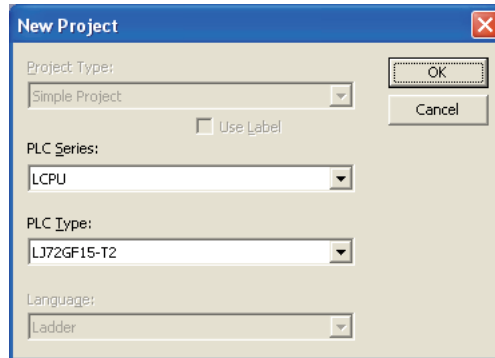

2. Display the PLC parameter setting window and configure the setting as follows.

 Project window ⇨ [Parameter] ⇨ [PLC Parameter] ⇨ "Communication Head Setting"

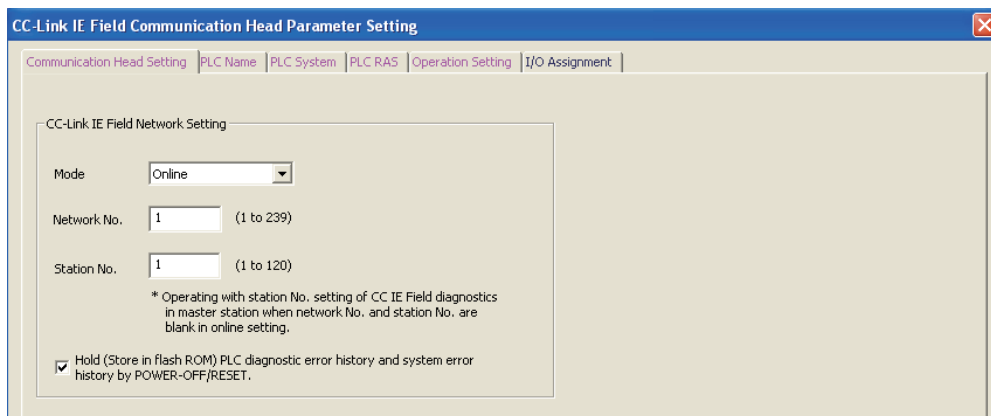

3. Add the L60TCTT4 to the project on GX Works2.

 Project window ⇨ [Intelligent Function Module] ⇨ Right-click ⇨ [New Module...]

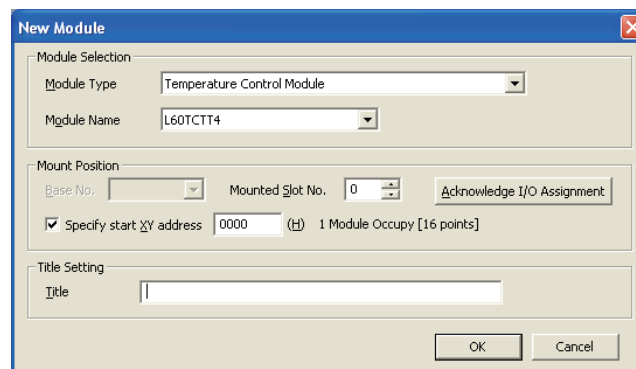

4. Display the L60TCTT4 Switch Setting window and configure the setting as follows.

Project window ⇨ [Intelligent Function Module] ⇨ [L60TCTT4] ⇨ [Switch Setting]

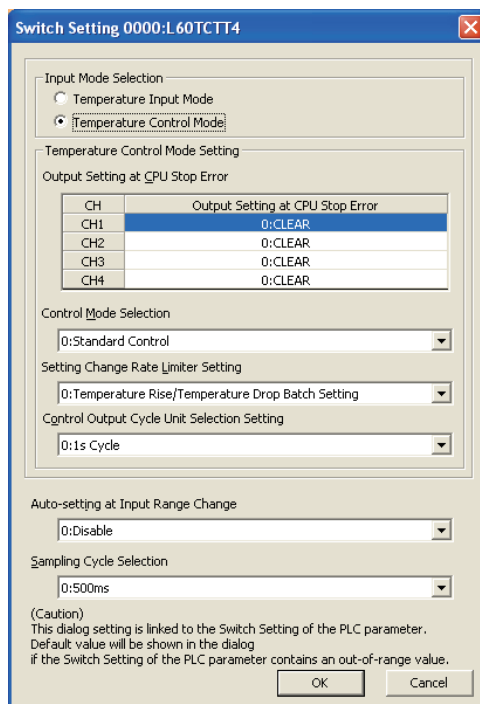

Item		Setting value			
		CH1	CH2	CH3	CH4
Input Mode Selection		Temperature Control Mode			
Temperature Control Mode Setting	Output Setting at CPU Stop Error	0: CLEAR	0: CLEAR	0: CLEAR	0: CLEAR
	Control Mode Selection	0: Standard Control			
	Setting Change Rate Limiter Setting	0: Temperature Rise/Temperature Drop Batch Setting			
	Control Output Cycle Unit Selection Setting	0: 1s Cycle			
Auto-setting at Input Range Change		0: Disable			
Sampling Cycle Selection		0: 500ms			

5. Display the L60TCTT4 initial setting window, click **Clear Value for Gray Cells**, and configure the setting as follows.

Project window ⇒ [Intelligent Function Module] ⇒ [L60TCTT4] ⇒ [Parameter]

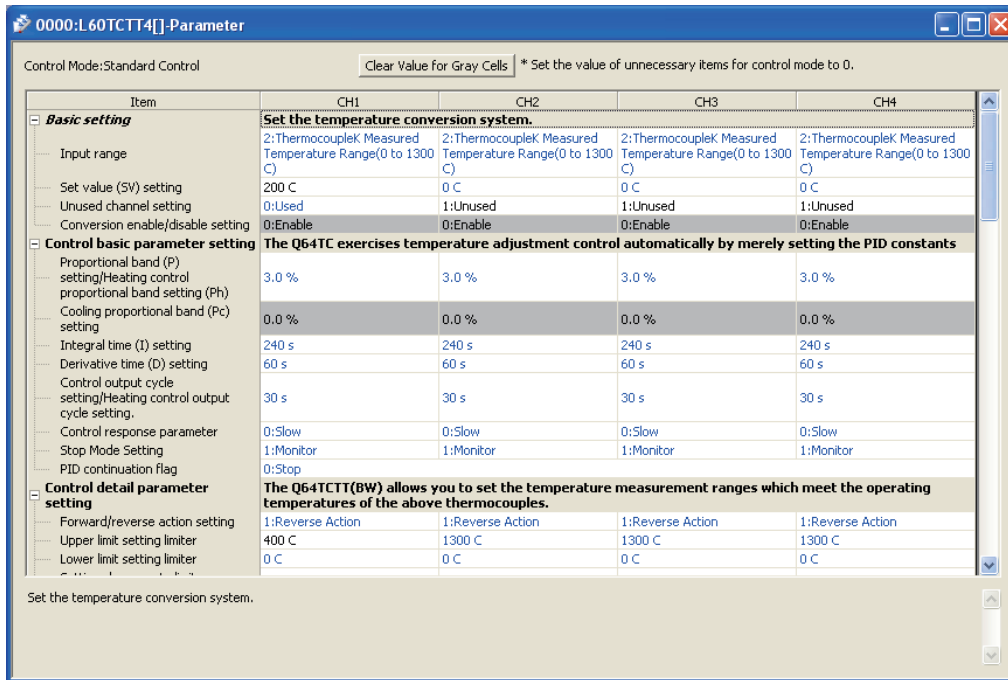

Item	Description	Setting value			
		CH1	CH2	CH3	CH4
Input range	Set the temperature sensor used for the L60TC4 and the measurement range.	2: ThermocoupleK Measured Temperature Range (0 to 1300°C)	2: ThermocoupleK Measured Temperature Range (0 to 1300°C)	2: ThermocoupleK Measured Temperature Range (0 to 1300°C)	2: ThermocoupleK Measured Temperature Range (0 to 1300°C)
Set value (SV) setting	Set the target temperature value of PID control.	200°C	0°C	0°C	0°C
Unused channel setting	Configure this setting when the channels where the temperature control is not performed and the temperature sensor is not connected are set to be unused.	0: Used	1: Unused	1: Unused	1: Unused
Upper limit setting limiter	Set the upper limit of the set value (SV).	400°C	1300°C	1300°C	1300°C
Lower limit setting limiter	Set the lower limit of the set value (SV).	0°C	0°C	0°C	0°C
Alert 1 mode setting	Set the alert mode.	1: Upper Limit Input Alert	0: Not Warning	0: Not Warning	0: Not Warning
Alert set value 1	Set the temperature where CH□ Alert 1 (b8 of Un\G5 to Un\G8) turns on depending on the selected alert mode.	500°C	—	—	—

6. Display the L60TCTT4 auto refresh setting window and configure the setting as follows.

Project window ⇨ [Intelligent Function Module] ⇨ [L60TCTT4] ⇨ Right-click ⇨ [Auto_Refresh]

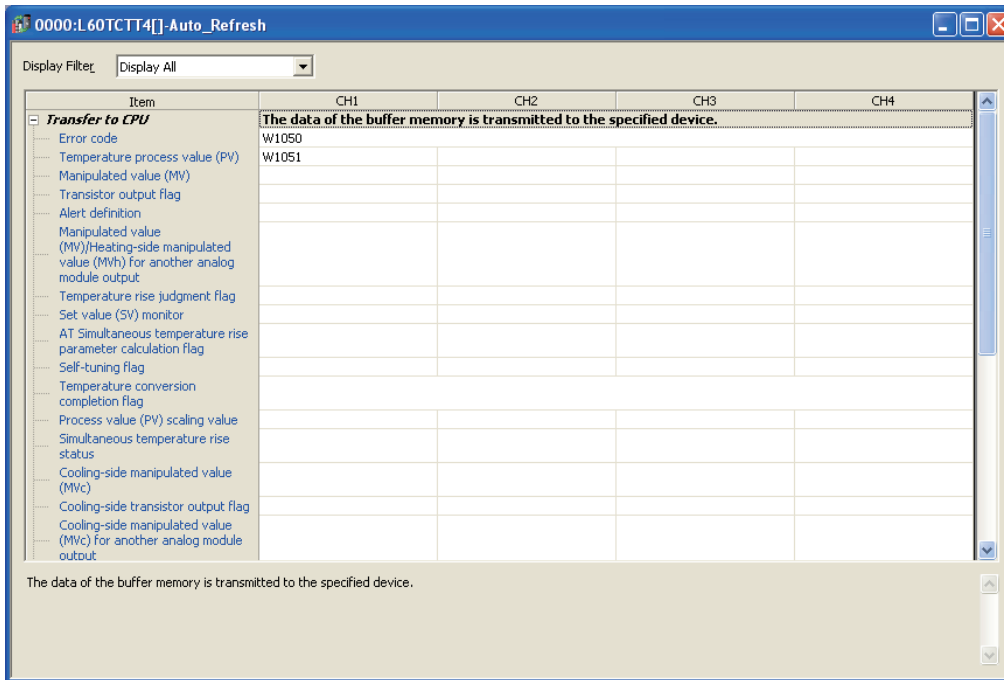

Item	Description	Setting value			
		CH1	CH2	CH3	CH4
Error code	An error code or alarm code is stored.	W1050			
Temperature process value (PV)	The detected temperature value where sensor correction is performed is stored.	W1051	—	—	—

7. Write the set parameter to the head module. Then reset the head module or turn off and on the power supply.

[Online] ⇨ [Write to PLC...]

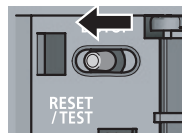

or Power OFF → ON

8. Perform auto tuning.

Set the "Automatic backup setting after auto tuning of PID constants" to "ON" and perform the auto tuning.

[Tool] ⇨ [Intelligent Function Module Tool] ⇨ [Temperature Control Module]
 ⇨ [Auto Tuning...] ⇨ "L60TCTT4" ⇨

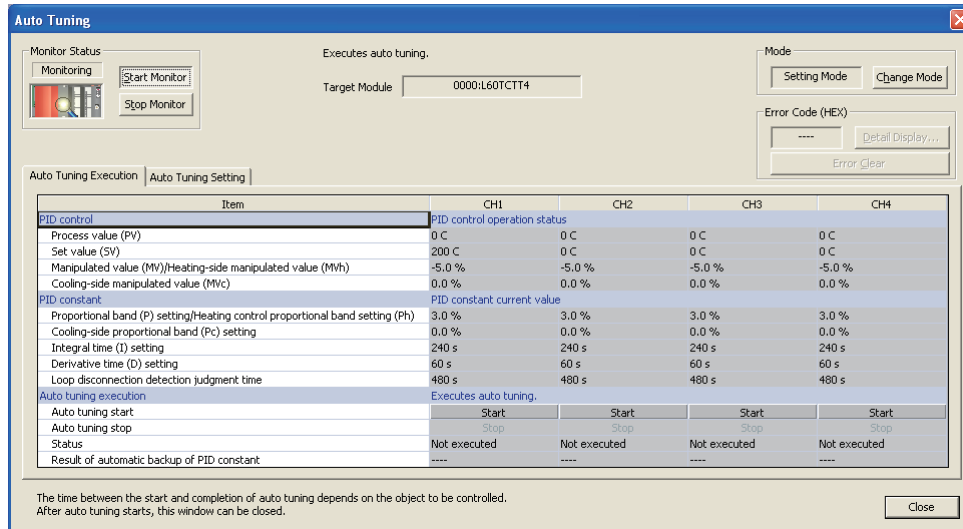

(a) Devices used by a user

Device	Description	
X22	Error code reset instruction	LX42C4 (X20 to X5F)
X23	Operation mode setting instruction	
X24	Memory of PID constants read instruction	
X1000	Module READY flag	L60TCTT4 (X1000 to X100F)
X1002	Error occurrence flag	
Y60 to Y6F	Error code output	LY42NT1P (Y60 to Y9F)
Y1001	Setting/operation mode instruction	L60TCTT4 (Y1000 to Y100F)
Y1002	Error reset instruction	
Y1008	Set value backup instruction	
Y100B	Setting change instruction	
D9	Write data storage device using Z(P).REMTO instruction (for non-volatile memory read of PID constants)	
D10	Read data storage device using Z(P).REMFR instruction (for non-volatile memory read of PID constants)	
D11	Write data storage device using Z(P).REMTO instruction (for non-volatile memory read of PID constants)	
M0	Master module status check device (for MC and MCR instructions)	
M300 to M305	CH1 Memory of PID constants read flag	
M310, M311	Z(P).REMTO instruction completion/result device	
M312, M313	Z(P).REMFR instruction completion/result device	
M314, M315	Z(P).REMTO instruction completion/result device	
W1050	Error code	Devices where data is written by auto refresh
W1051	CH1 Temperature process value (PV)	
SB49	Data link status (own station)	
SWB0.0	Data link status (each station) (station number 1)	

(b) Program example

Write the program to the CPU module on the master station.

- Program that checks the data link status of the head module



Check the data link status of the head module*1.

*1 Add the following MCR instruction to the end of the program.

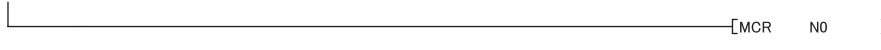

- Program that changes the setting/operation mode

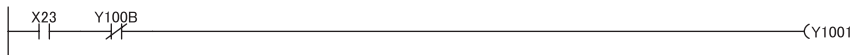

Change to the setting mode or the operation mode.

- Program that reads the PID constants from the non-volatile memory

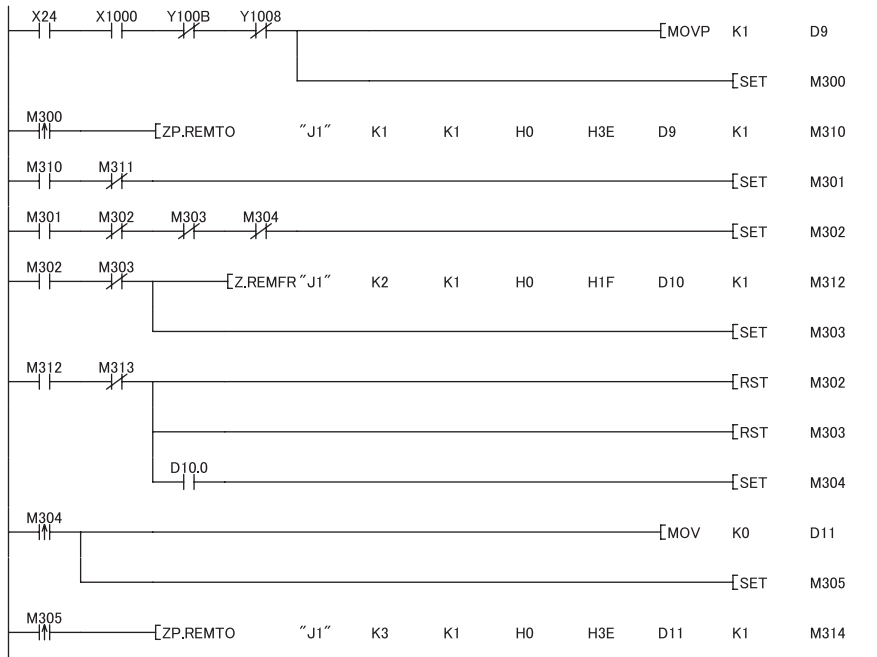

CH1 Memory's PID constant read instruction: With instruction

Read Memory's PID constant read/write completion flag to D10.

CH1 Memory's PID constant read instruction: Without instruction

- Program that reads an error code

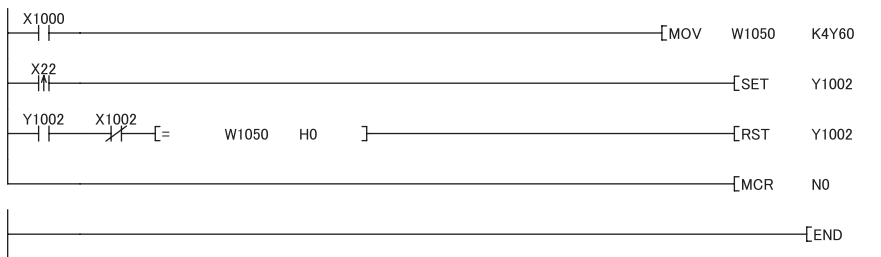

Output an error code to Y60 to Y6F.

Error reset instruction: ON

Error reset instruction: OFF

CHAPTER 11 TROUBLESHOOTING

This chapter describes the causes and corrective actions to take when a problem occurs in the L60TC4.

11.1 Before Troubleshooting

Check whether any of the following LEDs are on.

- The POWER LED on the power supply module
- The MODE LED on the CPU module or head module

If both are off, proceed with CPU module or head module troubleshooting.

- MELSEC-L CPU Module User's Manual (Hardware Design, Maintenance and Inspection)
- MELSEC-L CC-Link IE Field Network Head Module User's Manual

11.2 Troubleshooting Procedure

This section describes how to find problem causes and take corrective action.
Use GX Works2 to find problem causes and take corrective action.

(1) Procedure

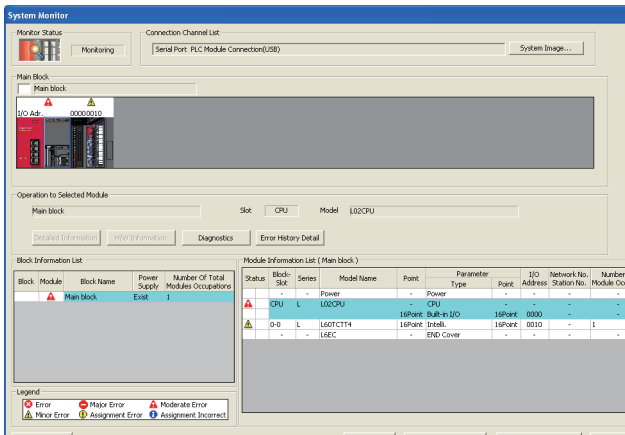

1. Connect GX Works2 to the CPU module to display the "System Monitor" window.

[Diagnostics] ⇒ [System Monitor...]

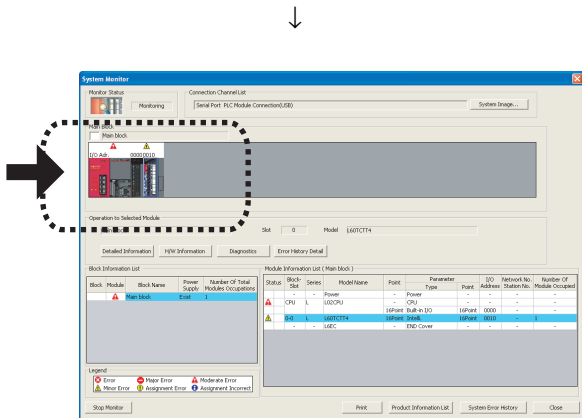

2. After confirming that an error is displayed on the L60TC4, select the L60TC4 and click **Detailed Information**.

If an error LED is ON on a module other than the L60TC4, refer to the user's manual for the module and take corrective action.

(To the next page)

(From the previous page)

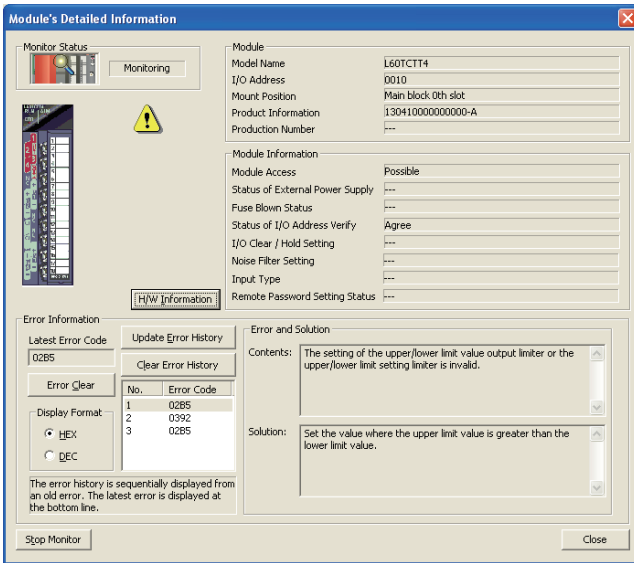

3. Click **Detailed Information** to open the "Module's Detailed Information" window.

Check the error description and the corrective action to take under "Error and Solution".

4. When the error description cannot be confirmed after doing the operation above, proceed with the following troubleshooting.

- Checks using LEDs (☞ Page 310, Section 11.3)
- Checks using input signals (☞ Page 312, Section 11.4)

11.3 Checks Using LEDs

This section describes troubleshooting using LEDs.

11.3.1 When the RUN LED flashes or turns off

Check Item	Action
Is the power supplied?	Check that the supply voltage of the power supply module is within the rated range.
Is the capacity of power supply module enough?	Calculate the current consumption of the installed CPU module, I/O module, and intelligent function module to check whether power supply capacity is sufficient.
Has a watchdog timer error occurred?	<ul style="list-style-type: none">• Reset the CPU module or turn on the power supply again.• Replace the L60TC4.
Is the intelligent function module switch setting value outside the setting range?	Set the switch setting value of the intelligent function module to the value within the setting range.

11.3.2 When the ERR. LED turns on or flashes

(1) When turning on

Check Item	Action
Is the intelligent function module switch setting outside the setting range?	Set the switch setting value of the intelligent function module to the value within the setting range.
Is the cold junction temperature compensation resistor disconnected or loose? (The L60TCTT4 and L60TCTT4BW only)	Properly connect the cold junction temperature compensation resistor.
Others	A hardware failure occurred in the L60TC4. Please consult your local Mitsubishi system service, service center, or representative, explaining a detailed description of the problem.

(2) When flashing

Check Item	Action
Has an error occurred?	Check the error code list (☞ Page 315, Section 11.6) and take actions described.

11.3.3 When the ALM LED turns on or flashes

(1) When turning on

Check Item	Action
Is CH□ Alert occurrence flag (XnC to XnF) on?	Check CH□ Alert definition (Un\G5 to Un\G8) and take the appropriate corrective action. (☞ Page 336, Appendix 2 (3))

(2) When flashing

Check Item	Action
Has the temperature process value (PV) exceeded the temperature measurement range set as the input range?	Change the setting of CH□ Input range (Un\G32, Un\G64, Un\G96, Un\G128) to a setting in the temperature measurement range to be used. (☞ Page 345, Appendix 2 (12))
Is there a channel where no temperature sensor is connected?	Set the channel where no temperature sensor is connected to unused in CH□ Unused channel setting (Un\G61, Un\G93, Un\G125, Un\G157). (☞ Page 376, Appendix 2 (35))
Has a loop disconnection been detected?	Check for a load disconnection, externally-operable device failure, and sensor disconnection.

11.4 Checks Using Input Signals

This section describes troubleshooting using input signals.

11.4.1 When Module READY flag (Xn0) does not turn on

Check Item	Action
Has a watchdog timer error occurred?	<ul style="list-style-type: none">• Reset the CPU module or turn on the power supply again.• Replace the L60TC4.
Has an error occurred in the programmable controller?	Refer to the user's manual of the used CPU module and take corrective action.



11.4.2 When Error occurrence flag (Xn2) is on

Check Item	Action
Has an error occurred?	Check the error code list ( Page 315, Section 11.6) and take actions described.

11.4.3 When Hardware error flag (Xn3) is on

Check Item	Action
Is the cold junction temperature compensation resistor disconnected or loose? (The L60TCTT4 and L60TCTT4BW only)	Properly connect the cold junction temperature compensation resistor.
Others	A hardware failure occurred in the L60TC4. Please consult your local Mitsubishi system service, service center, or representative, explaining a detailed description of the problem.

11.4.4 When the auto tuning does not start (CH□ Auto tuning status (Xn4 to Xn7) does not turn on)

Check Item	Action
Have the auto tuning start conditions been met?	Refer to the "Auto tuning function" section ( Page 141, Section 8.2.7) and confirm that all conditions have been met.
Has auto tuning ended abnormally?	Check the conditions that signify an abnormal end for auto tuning ( Page 150, Section 8.2.7 (7)) to see whether it has ended abnormally. If it has ended abnormally, remove the cause. Then execute auto tuning again.

11.4.5 When the auto tuning does not complete (CH□ Auto tuning status (Xn4 to Xn7) stays on and does not turn off)

Check Item	Action
Are b4 to b7 of Memory of PID constants read/write completion flag (Un\G31) set to 1 (ON)?	Set CH□ Automatic backup setting after auto tuning of PID constants (Un\G63, Un\G95, Un\G127, Un\G159) to Disable (0). (☞ Page 378, Appendix 2 (37)) To back up the setting, turn off and on Set value backup instruction (Yn8).
Is CH□ Memory of PID constants read instruction (Un\G62, Un\G94, Un\G126, Un\G158) set to Requested (1)?	Set CH□ Memory of PID constants read instruction (Un\G62, Un\G94, Un\G126, Un\G158) to Not requested (0). (☞ Page 377, Appendix 2 (36))
Has the set value (SV) been set correctly? (Is the manipulated value (MV) still 0% because the set value (SV) is small?)	Set the set value (SV) to the desired value.

11.4.6 When the self-tuning does not start (CH□ Auto tuning status (Xn4 to Xn7) does not turn on)

Check Item	Action
Have the self-tuning start conditions been met?	Refer to the "Self-tuning function" section (☞ Page 175, Section 8.2.15) and confirm that all conditions have been met.
Has self-tuning ended abnormally?	Check the conditions that signify an abnormal end for self-tuning (☞ Page 183, Section 8.2.15 (8)) to see whether it has ended abnormally. If it has ended abnormally, remove the cause. If the buffer memory setting was changed during self-tuning, restore the value to the one prior to change.

11.4.7 When Back-up of the set value fail flag (XnA) is on

Check Item	Action
Has a backup to non-volatile memory failed?	Turn off and on Set value backup instruction (Yn8) and write the setting to the non-volatile memory. When writing fails again, a hardware is in failure. Please consult your local Mitsubishi system service, service center, or representative, explaining a detailed description of the problem.

11.4.8 When CH□ Alert occurrence flag (XnC to XnF) is on

Check Item	Action
Has the temperature process value (PV) exceeded the alert set value range?	<ul style="list-style-type: none"> • Check CH□ Alert definition (Un\G5 to Un\G8) and take the appropriate corrective action. (☞ Page 336, Appendix 2 (3)) • Correct the alert set value. (☞ Page 358, Appendix 2 (18))
Has a disconnection been detected?	<ul style="list-style-type: none"> • Check CH□ Alert definition (Un\G5 to Un\G8) and take the appropriate corrective action. (☞ Page 336, Appendix 2 (3))

11.5 Troubleshooting by Symptom

This section describes troubleshooting using the wiring resistance values of thermocouples.

11.5.1 When the temperature process value (PV) is abnormal

Check Item	Action
Is the thermocouple wiring resistance value too high?	<ul style="list-style-type: none">• Check the thermocouple wiring resistance value and check whether a difference in the temperatures was caused by the wiring resistance. (☞ Page 36, Section 3.2.2 (1))• Use the sensor compensation function to correct the difference in the temperatures caused by the wiring resistance. (☞ Page 223, Section 8.3.2 (2))

11.6 Error Code List

When the L60TC4 error occurs during data write to the CPU module or during data read from the CPU module, one of the following error codes is stored in Error code (Un\G0).

In addition, the error occurred is notified to the CPU module.

Error code (hexadecimal)	Cause	Operation at error occurrence	Action
0001 _H	Hardware error	The operation varies depending on the symptom.	<ul style="list-style-type: none"> • Check that the terminal block or the cold junction temperature compensation resistor is not disconnected or loose. • Replace the L60TC4. • Please consult your local Mitsubishi system service, service center, or representative, explaining a detailed description of the problem.
□□□2 _H ^{*1}	Data (other than 0) is being written to the system area ^{*2} .	<ul style="list-style-type: none"> • The data written is retained. • When data is written to multiple system areas, the address with the smallest number of the buffer memory area where an error was detected is stored.^{*5} 	<ul style="list-style-type: none"> • Return the value to 0 and turn off, on, and off Error reset instruction (Yn2). • Delete the program that is writing data to the system area.
□□□3 _H ^{*1}	Data is being written in the operation mode ^{*4} to the area where data can be written only in the setting mode ^{*3} .	<ul style="list-style-type: none"> • The data written is retained. • When data is written to multiple system areas, the address with the smallest number of the buffer memory area where an error was detected is stored.^{*5} 	<ul style="list-style-type: none"> • Follow the instructions below for error reset. <ol style="list-style-type: none"> 1. Change the mode to the setting mode. 2. Set the correct value and turn off, on, and off Setting change instruction (YnB). 3. Turn off, on, and off Error reset instruction (Yn2). • If switching from the operation mode to the setting mode, check that PID continuation flag (Un\G169) is set to Stop (0), and turn on and off Setting/operation mode instruction (Yn1).
□□□4 _H ^{*1}	Data outside the settable range is being written.	<ul style="list-style-type: none"> • The data written is retained. • If temperature, time, or percentage settings exceed upper limit value/lower limit value, change the data within those values. • When data is written to multiple system areas, the address with the smallest number of the buffer memory area where an error was detected is stored.^{*5} 	Set data within the range.
□□□5 _H ^{*1}	The setting of the upper/lower limit value output limiter or the upper/lower limit setting limiter is invalid.	<ul style="list-style-type: none"> • The data written is retained. • Change the setting to an allowable value for the upper/lower limit value. • When data is written to multiple system areas, the address with the smallest number of the buffer memory area where an error was detected is stored.^{*5} 	Set the value where the upper limit value is greater than the lower limit value.

Error code (hexadecimal)	Cause	Operation at error occurrence	Action
□□□6 _H ^{*1}	The setting value is being changed while Default setting registration instruction (Yn9) was on.	<ul style="list-style-type: none"> The data written is ignored. The setting cannot be changed until an error reset is performed. The content of Error code (Un\G0) does not change even if another write error occurs. 	After turning off, on, and off Error reset instruction (Yn2), change the setting value.
□□□7 _H ^{*1}	The sensor two-point correction setting is invalid.	<ul style="list-style-type: none"> The data written is retained. Use the data of before the setting. When data is written to multiple system areas, the address with the smallest number of the buffer memory area where an error was detected is stored.^{*5} When both the offset value and gain value are within the input range and the offset value is greater than or equal to the gain value, the gain value address is stored as the address where the error occurred. 	<ul style="list-style-type: none"> Enter the temperature within the input range. Set the values so that the sensor two-point correction offset value (measured value) is smaller than the sensor two-point correction gain value (measured value) and the sensor two-point correction offset value (corrected value) is smaller than the sensor two-point correction gain value (corrected value).
□□□8 _H ^{*1}	<p>The setting is described by one of the following.</p> <ul style="list-style-type: none"> The process alarm upper upper limit value is smaller than the upper lower limit value. The process alarm upper lower limit value is smaller than the lower upper limit value. The process alarm lower upper limit value is smaller than the lower lower limit value. 	<ul style="list-style-type: none"> The data written is retained. the address with the smallest number of the buffer memory area where an error was detected is used as the address where the error occurred. Use the data of before the setting. When data is written to multiple system areas, the address with the smallest number of the buffer memory area where an error was detected is stored.^{*5} 	<p>Set the values that meet the following conditions.</p> <ul style="list-style-type: none"> Process alarm upper upper limit value ≥ Upper lower limit value Process alarm upper lower limit value ≥ Lower upper limit value Process alarm lower upper limit value ≥ Lower lower limit value
□□□A _H	<p>An alarm has occurred. Refer to the alarm code list ( Page 318, Section 11.7).</p>		
0□□E _H ^{*6}	<p>A set value discrepancy error occurred. The current set value is different from the set value backed up in non-volatile memory because one of the following settings on Switch Setting has been changed.</p> <ul style="list-style-type: none"> Control Mode Selection Control Output Cycle Unit Selection Setting Sampling Cycle Selection 	<ul style="list-style-type: none"> The set value cannot be changed until the control mode is determined. When the setting under "Control Mode Selection" was changed: All parameters are overwritten with defaults. When the setting under "Control Output Cycle Unit Selection Setting" was changed: Settings are overwritten with defaults for "Control Output Cycle Setting", "Heating Control Output Cycle Setting", and "Cooling Control Output Cycle Setting"; other settings are overwritten with backed up values. When the setting under "Sampling Cycle Selection" was changed: All parameters are overwritten with defaults. 	Turn off, on, and off Set value backup instruction (Yn8).
000F _H	Values set in the intelligent function module switch setting are those outside the setting range.	The RUN LED turns off, the ERR. LED turns on, and the module does not operate.	Set the correct values on the intelligent function module switch setting.

- *1 The address where the error occurred is stored in □□□_H.
Buffer memory addresses are written in decimal (Intelligent function module device (Un\G□)) in this manual. Read the stored value in decimal and refer to the buffer memory list (Page 44, Section 3.5).
- *2 The buffer memory areas checked are Un\G0 to Un\G287. No error occurs for writes in the system area in or after Un\G288.
- *3 For the writable area in setting mode, refer to the buffer memory list (Page 44, Section 3.5).
- *4 "In the operation mode" refers to one of the following states.
 - When Setting/operation mode instruction (Yn1) or Setting/operation mode status (Xn1) is on.
 - When Setting/operation mode instruction (Yn1) turns on and off and PID continuation flag (Un\G169) is set to Continue (1).
- *5 **Ex.** When an error occurs in CH1 Alert 1 mode setting (Un\G192) and CH1 Alert 2 mode setting (Un\G193), 0C0_H (hex) in the buffer memory address with the smallest number "Un\G192" is stored in Error code (Un\G0).
- *6 The error code for a set value discrepancy error indicates the match/no match status with the set value on Switch Setting backed up to non-volatile memory as follows.

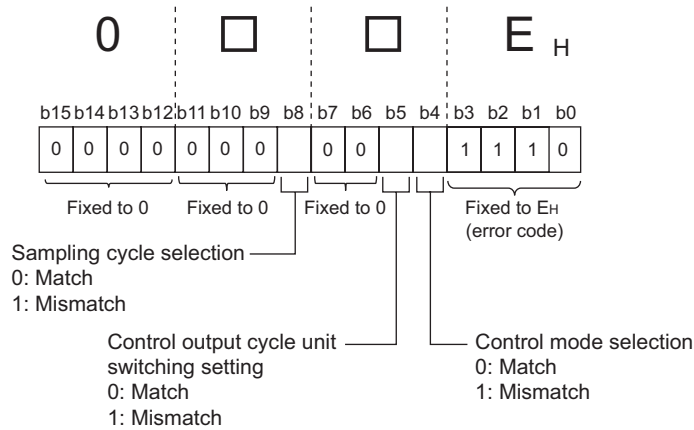

Remark

- When a value outside the setting range is written in the following buffer memory areas while in setting mode, the error code 4_H is stored. Switching to operation mode without error reset changes the error code to 3_H. If this happens, take the corrective action for error code 3_H.

Buffer memory area name	Buffer memory address				Reference
	CH1	CH2	CH3	CH4	
Input range	Un\G32	Un\G64	Un\G96	Un\G128	Page 345, Appendix 2 (12)
Alert 1 mode setting	Un\G192	Un\G208	Un\G224	Un\G240	Page 386, Appendix 2 (52)
Alert 2 mode setting	Un\G193	Un\G209	Un\G225	Un\G241	
Alert 3 mode setting	Un\G194	Un\G210	Un\G226	Un\G242	
Alert 4 mode setting	Un\G195	Un\G211	Un\G227	Un\G243	

- Error code priorities are as described below.
- Priority
- 1 ← F ← E ← 6 ← 3 ← 7 ← 5,8 ← 2,4 When error codes are in the same priority level, the lower error addresses are prioritized.
- Higher Lower
- When a high-priority error occurs during a low-priority error, the error code of the high-priority error is written over the error occurrence address.
- Only one error code, as dictated by error priority, is stored in Error code (Un\G0). For that reason, when multiple errors occur at the same time, the next error code is stored, even when the error of the stored error code is corrected. Check for errors other than the stored error code in the parameters of other channels.

11.7 Alarm Code List

The following table lists alarm codes.

The alarm code is stored in all bits of Error code (Un\G0).

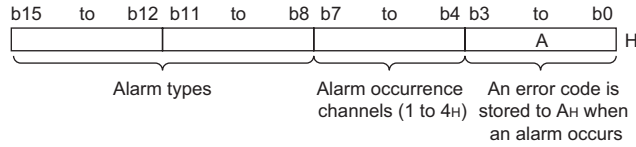

If the lower four bits are "0001" (1_H) to "1001" (9_H) or "1011" (B_H) to "1111" (F_H), an error occurs. When an error occurs, refer to the error code list (☞ Page 315, Section 11.6).

Alarm code (hexadecimal) *1	Cause	Operation at alarm occurrence	Action
01□A _H	The temperature process value (PV) has exceeded the temperature measurement range that was set as the input range.	<ul style="list-style-type: none"> The ALM LED flashes. CH□ Alert occurrence flag (XnC to XnF) turns on. CH□ Input range upper limit (b0 of Un\G5 to Un\G8) turns on. 	When Error reset instruction (Yn2) is turned OFF → ON → OFF after the temperature process value (PV) has returned to the value within the temperature measurement range, Error code (Un\G0) is cleared to 0.
02□A _H	The temperature process value (PV) is below the temperature measurement range that was set as the input range.	<ul style="list-style-type: none"> The ALM LED flashes. CH□ Alert occurrence flag (XnC to XnF) turns on. CH□ Input range lower limit (b1 of Un\G5 to Un\G8) turns on. 	<p>The following flags and buffer memory bits that turn on when an alarm occurs turn off automatically when the temperature process value (PV) has returned to the value within the temperature measurement range.</p> <ul style="list-style-type: none"> CH□ Alert occurrence flag (XnC to XnF) The applicable bit (☞ Page 336, Appendix 2 (3)) of CH□ Alert definition (Un\G5 to Un\G8)
03□A _H	A loop disconnection has been detected.	<ul style="list-style-type: none"> The ALM LED flashes. CH□ Alert occurrence flag (XnC to XnF) turns on. CH□ Loop disconnection detection (b13 of Un\G5 to Un\G8) turns on. 	When Error reset instruction (Yn2) is turned OFF → ON → OFF after a current error due to a disconnection or output-off is restored, Error code (Un\G0) is cleared to 0.
04□A _H	A heater disconnection has been detected.	<ul style="list-style-type: none"> The HBA LED turns on. CH□ Alert occurrence flag (XnC to XnF) turns on. CH□ Heater disconnection detection (b12 of Un\G5 to Un\G8) turns on. 	<p>The following flags and buffer memory bits that turn on when an alarm occurs turn off automatically when the current error due to disconnection or output-off is restored.</p> <ul style="list-style-type: none"> CH□ Alert occurrence flag (XnC to XnF) The applicable bit (☞ Page 336, Appendix 2 (3)) of CH□ Alert definition (Un\G5 to Un\G8)
05□A _H	A current error at an output off-time has been detected.	<ul style="list-style-type: none"> The HBA LED turns on. CH□ Alert occurrence flag (XnC to XnF) turns on. CH□ Output off-time current error (b14 of Un\G5 to Un\G8) turns on. 	<ul style="list-style-type: none"> The applicable bit (☞ Page 336, Appendix 2 (3)) of CH□ Alert definition (Un\G5 to Un\G8)

Alarm code (hexadecimal) *1	Cause	Operation at alarm occurrence	Action
06□A _H	Alert 1 has occurred.	<ul style="list-style-type: none"> The ALM LED turns on. CH□ Alert occurrence flag (XnC to XnF) turns on. CH□ Alert 1 (b8 of Un\G5 to Un\G8) turns on. 	<p>When Error reset instruction (Yn2) is turned OFF → ON → OFF after the temperature process value (PV) is restored from alert status, Error code (Un\G0) is cleared to 0.</p> <p>The following flags and buffer memory bits that turn on when an alarm occurs turn off automatically when the temperature process value (PV) is restored from alert status.</p> <ul style="list-style-type: none"> CH□ Alert occurrence flag (XnC to XnF) The applicable bit (☞ Page 336, Appendix 2 (3)) of CH□ Alert definition (Un\G5 to Un\G8)
07□A _H	Alert 2 has occurred.	<ul style="list-style-type: none"> The ALM LED turns on. CH□ Alert occurrence flag (XnC to XnF) turns on. CH□ Alert 2 (b9 of Un\G5 to Un\G8) turns on. 	
08□A _H	Alert 3 has occurred.	<ul style="list-style-type: none"> The ALM LED turns on. CH□ Alert occurrence flag (XnC to XnF) turns on. CH□ Alert 3 (b10 of Un\G5 to Un\G8) turns on. 	
09□A _H	Alert 4 has occurred.	<ul style="list-style-type: none"> The ALM LED turns on. CH□ Alert occurrence flag (XnC to XnF) turns on. CH□ Alert 4 (b11 of Un\G5 to Un\G8) turns on. 	
0A□A _H	A process alarm upper limit alert has occurred.	<ul style="list-style-type: none"> The ALM LED turns on. CH□ Alert occurrence flag (XnC to XnF) turns on. CH□ Process alarm upper limit alert (b2 of Un\G5 to Un\G8) turns on. 	<p>When Error reset instruction (Yn2) is turned OFF → ON → OFF after the temperature process value (PV) is restored from alert status, Error code (Un\G0) is cleared to 0.</p> <p>The following flags and buffer memory bits that turn on when an alarm occurs turn off automatically when the temperature process value (PV) is restored from alert status.</p> <ul style="list-style-type: none"> CH□ Alert occurrence flag (XnC to XnF) The applicable bit (☞ Page 336, Appendix 2 (3)) of CH□ Alert definition (Un\G5 to Un\G8)
0B□A _H	A process alarm lower limit alert has occurred.	<ul style="list-style-type: none"> The ALM LED turns on. CH□ Alert occurrence flag (XnC to XnF) turns on. CH□ Process alarm upper limit alert (b3 of Un\G5 to Un\G8) turns on. 	
0C□A _H	A rate alarm upper limit alert has occurred.	<ul style="list-style-type: none"> The ALM LED turns on. CH□ Alert occurrence flag (XnC to XnF) turns on. CH□ Rate alarm upper limit alert (b4 of Un\G5 to Un\G8) turns on. 	
0D□A _H	A rate alarm lower limit alert has been occurred.	<ul style="list-style-type: none"> The ALM LED turns on. CH□ Alert occurrence flag (XnC to XnF) turns on. CH□ Process alarm upper limit alert (b5 of Un\G5 to Un\G8) turns on. 	

*1 □ represents the number of the channel (1_H to 4_H) where the alarm occurred.

Remark

- The error code is always given priority over the alarm code for being stored in Error code (Un\G0). For that reason, when an alarm occurs during an error, the alarm code is not stored in Error code (Un\G0). Further, when an error occurs during an alarm, the error code is written over the alarm code in Error code (Un\G0).
- Alarm priorities are as follows.

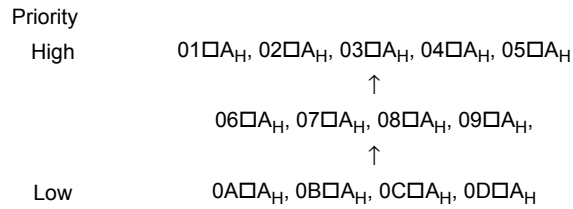

When an alarm occurs, if its priority is the same as or higher than that of alarms already occurred, the new alarm code is written over Error code (Un\G0).

11.8 Check the L60TC4 Status

The error code and hardware status can be checked by selecting "Module's Detailed Information" of the L60TC4 in the system monitor of the programming tool.

(1) Operating the programming tool

From [Diagnostics] ⇨ [System Monitor...] ⇨ "Main Block", select L60TC4 ⇨ **Detailed Information** .

(2) Module's Detailed Information

(a) Checking the function version and product information

The Product Information field shows the L60TC4 function version and product information.

(b) Checking the error code

The Latest Error Code field shows the error code stored in Error code (Un\G0) in the L60TC4.

(Press **Update Error History** to display the content shown under Latest Error Code as No.1.)

The screenshot shows the 'Module's Detailed Information' window. Key elements include:

- Module Information:**
 - Model Name: L60CTT4
 - I/O Address: 0010
 - Mount Position: Main block 0th slot
 - Product Information: 13041000000000-A (Annotated as 'Product information')
 - Production Number: ---
- Module Information (Status):**
 - Module Access: Possible
 - Status of External Power Supply: ---
 - Fuse Blown Status: ---
 - Status of I/O Address Verify: Agree
 - I/O Clear / Hold Setting: ---
 - Noise Filter Setting: ---
 - Input Type: ---
 - Remote Password Setting Status: ---
- Error Information:**
 - Latest Error Code: 02B5
 - Buttons: Update Error History, Clear Error History
 - Table:

No.	Error Code
1	02B5
2	0392
3	02B5
 - Display Format: HEX, DEC
- Error and Solution:**
 - Contents: The setting of the upper/lower limit value output limiter or the upper/lower limit setting limiter is invalid.
 - Solution: Set the value where the upper limit value is greater than the lower limit value.

(3) Hardware information

On the "Module's Detailed Information" window, click H/W Information.

(a) H/W LED information

The following information is displayed.

Item	Value	Condition for 0001 _H
RUN	<ul style="list-style-type: none"> • 0000_H: off • 0001_H: on 	Operating normally (same as the RUN LED)
DATA ERR		A write data error has occurred
CH□ RUN		PID control is being run
CH□ ALM1		Alert 1 is on
CH□ ALM2		Alert 2 is on
CH□ ALM3		Alert 3 is on
CH□ ALM4		Alert 4 is on
CH□ LBA		A loop disconnection has been detected
CH□ HBA		A heater disconnection has been detected (the L60TCTT4BW and L60TCRT4BW only)
H/W ERR		A hardware error has occurred

(b) H/W switch information

The setting status of the intelligent function module switch setting is displayed.

Item	Intelligent function module switch setting	Value
HOLD/CLR	Switch 1: Output Setting at CPU Stop Error	Refer to Page 108, Section 7.2
CTRL MODE	Switch 2: Control Mode Selection	
SW3	Switch 3: <ul style="list-style-type: none"> • Setting Change Rate Limiter Setting • Control Output Cycle Unit Selection Setting • Output Setting at CPU Stop Error • Auto-setting at Input Range Change • Sampling Cycle Selection 	

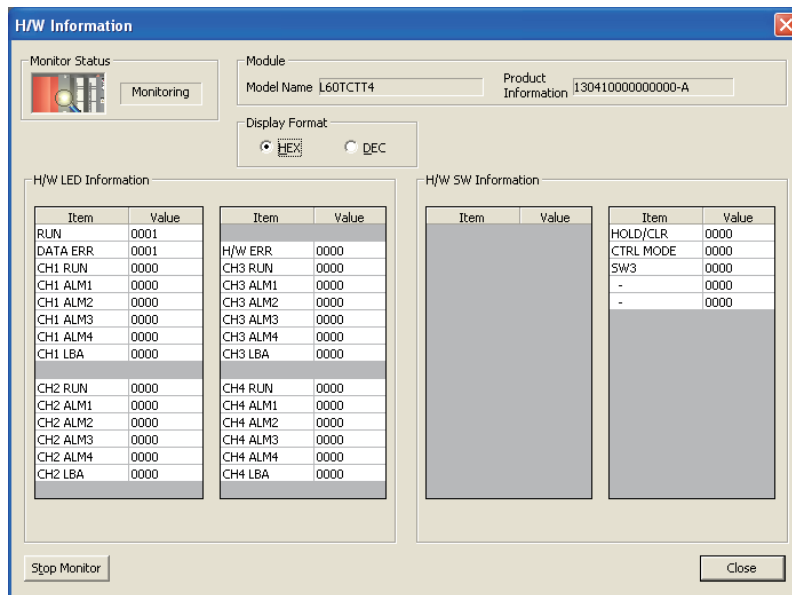

APPENDICES

Appendix 1 Details of I/O Signals

The following section describes the details of the L60TC4 I/O signals toward the CPU module. The I/O numbers (X/Y) described in Appendix 1 is for the case when the start I/O number of the L60TC4 is set to 0.

Appendix 1.1 Input signal

A

(1) Module READY flag (Xn0)

This flag turns on to indicate that the preparation for the L60TC4 is completed when the module is turned on from off or when the CPU module's reset is released.

Make sure that this flag is on when reading/writing data from/in the buffer memory of the L60TC4 from the CPU module. The following shows an example of a program. (In the following example, the start I/O number of the L60TC4 is set to 10.)

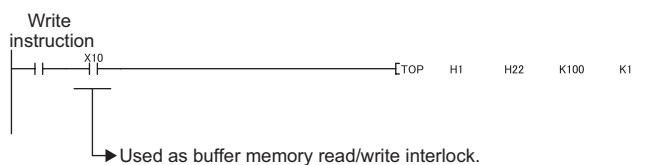

If the watchdog timer error is detected, this flag turns off. The L60TC4 stops controlling the temperature and the transistor output turns off. (The RUN LED turns off and ERR. LED turns on.)

(2) Setting/operation mode status (Xn1)

This signal turns on at the operation mode, off at the setting mode.

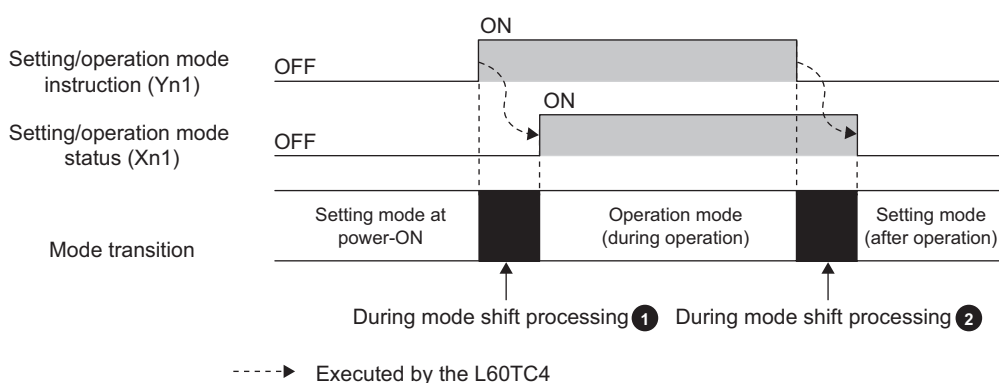

(a) Precautions during the mode shifting

The mode shifting means the following timings.

- From Setting/operation mode instruction (Yn1) OFF → ON to Setting/operation mode status (Xn1) ON (above figure ①)
- From Setting/operation mode instruction (Yn1) ON → OFF to Setting/operation mode status (Xn1) OFF (above figure ②)

During the mode shifting, do not change the set values. If the set values are changed during the mode shifting, the module operation cannot be guaranteed. Use Setting/operation mode status (Xn1) as an interlock condition for Setting/operation mode instruction (Yn1) when changing the setting.

Point

The conditions whether to perform the temperature judgment, PID control, and alert judgment by the L60TC4 differ among the following timings.

- Setting mode at power-ON
- Operation mode (in operation)
- Setting mode (after operation)

For each detail on the temperature judgment, PID control, and alert judgment, refer to the following.



- Temperature judgment: Page 336, Appendix 2 (3)
- PID control: Page 134, Section 8.2.3 (6)
- Alert judgment: Page 166, Section 8.2.11 (5)

(3) Error occurrence flag (Xn2)

This flag turns on when errors other than a hardware error occur.

After an error occurs and the error code is stored in Error code (Un\G0), this flag turns on.

Errors occur under the following conditions.

- When data is set in the buffer memory of the system area
- When the setting of the area which can be written only during the setting mode (Setting/operation mode status (Xn1): OFF) is changed during the operation mode (Setting/operation mode status (Xn1): ON)
( Page 324, Appendix 1.1 (2))
- When the data which cannot be set is set
- When the setting of the buffer memory is changed during the default setting registration ( Page 332, Appendix 1.2 (5))
- When the current set value and the set value backed up in the non-volatile memory are different due to the change on Switch Setting.

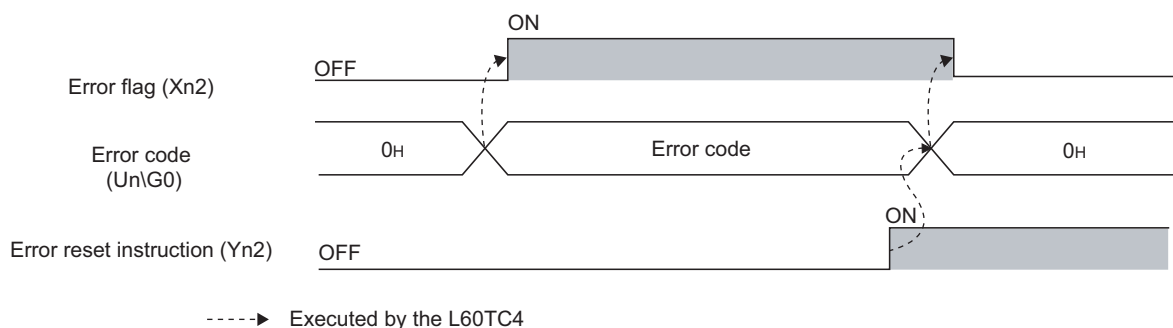

(4) Hardware error flag (Xn3)

This flag turns on when hardware error occurs in the L60TC4.

(5) CH□ Auto tuning status (Xn4 to Xn7)

This signal turns on when auto tuning of each channel is set by the user or when the L60TC4 performs self-tuning.

Channel	Auto tuning status			ON/OFF status
	Standard control	Heating-cooling control	Mix control	
CH1	Xn4	Xn4	Xn4	ON: The auto tuning/self-tuning is being performed. OFF: The auto tuning/self-tuning is not being performed or is completed.
CH2	Xn5	Xn5	Xn5* ²	
CH3	Xn6	Xn6* ¹	Xn6	
CH4	Xn7	Xn7* ¹	Xn7	

*1 Available only under the heating-cooling control (expanded mode). For details on the expanded mode, refer to  Page 127, Section 8.2.1 (3).

*2 Available only under the mix control (expanded mode). For details on the expanded mode, refer to  Page 127, Section 8.2.1 (3).

(a) Performing auto tuning

To perform auto tuning, turn CH□ Auto tuning instruction (Yn4 to Yn7) on from off.

While auto tuning is in process, this signal is on, and turns off at the completion of the auto tuning.

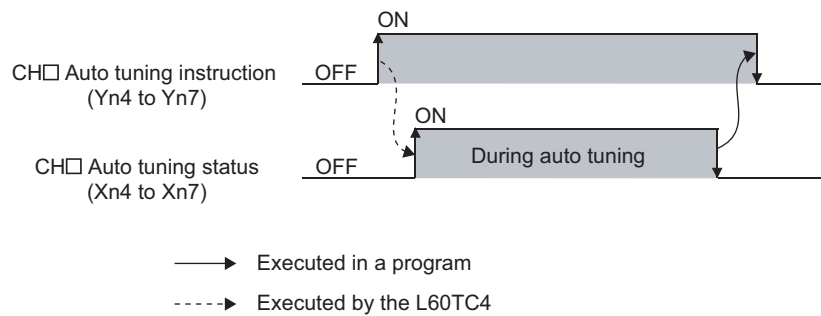

For details on the auto tuning function, refer to the following.

 Page 141, Section 8.2.7

(b) Self-tuning

This signal turns on when self-tuning starts. This signal automatically turns off at the completion of the self-tuning.

Set a self-tuning option in CH□ Self-tuning setting (Un\G574, Un\G606, Un\G638, Un\G670). ( Page 399, Appendix 2 (72)) Self-tuning can be executed only in the standard control.

For details on the self-tuning function, refer to the following.

 Page 175, Section 8.2.15

(6) Back-up of the set value completion flag (Xn8)

Turning Set value backup instruction (Yn8) on from off starts the writing of the buffer memory data to the non-volatile memory. After the data writing is completed, this flag turns on. Turning Set value backup instruction (Yn8) off from on also turns off this flag.

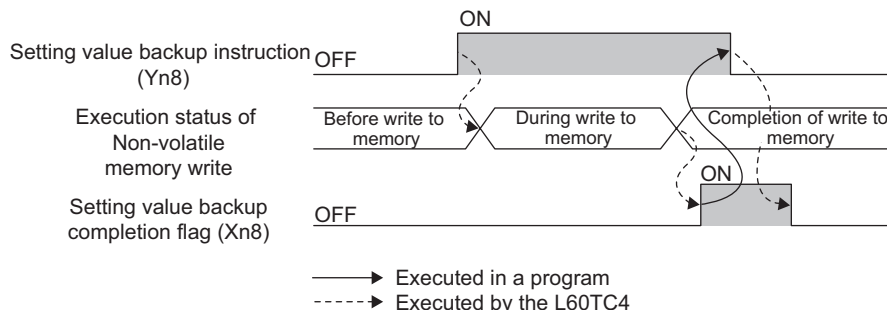

For details on the data writing to the non-volatile memory, refer to the following.

☞ Page 235, Section 8.3.4

(7) Default value write completion flag (Xn9)

Turning Default setting registration instruction (Yn9) on from off starts the writing of the default value of the L60TC4 to the buffer memory. After the data writing is completed, this flag turns on. Turning Default setting registration instruction (Yn9) off from on also turns off this flag.

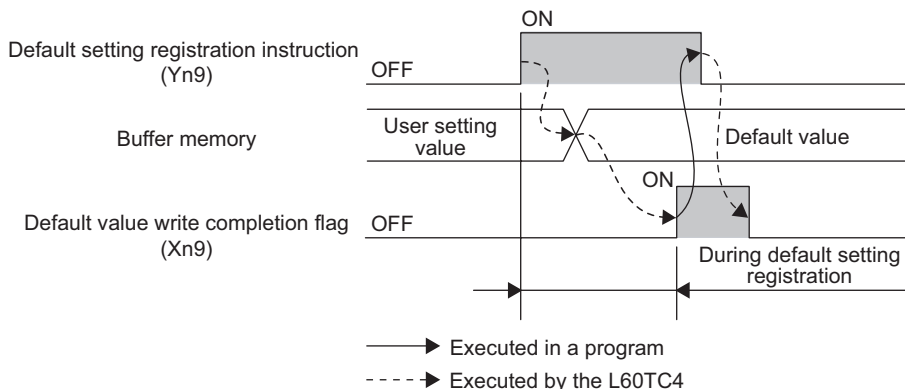

(a) Unused channel

For unused channels (which temperature sensors are not connected to), CH□ Unused channel setting (Un\G61, Un\G93, Un\G125, Un\G157) must be set to Unused (1) after the completion of the writing of the default value.

If not, ALM LED blinks.

For details on the unused channel setting, refer to the following.

☞ Page 106, Section 6.6

A

Appendix 1 Details of I/O Signals
Appendix 1.1 Input signal

(8) Back-up of the set value fail flag (XnA)

Turning Set value backup instruction (Yn8) on from off starts the writing of the buffer memory data to the non-volatile memory. This flag turns on when the writing failed.

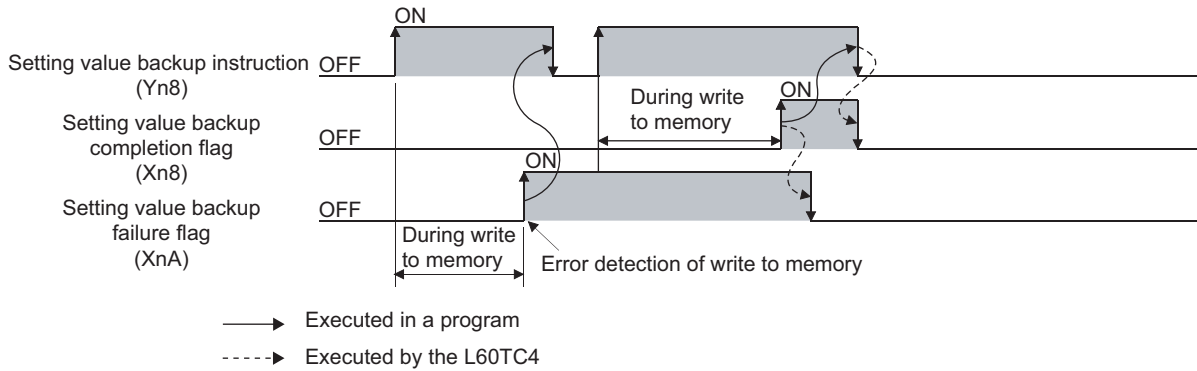

After the data writing is completed properly, this flag turns off.

For details on the data writing to the non-volatile memory, refer to the following.

👉 Page 235, Section 8.3.4

Point

After Set value backup instruction (Yn8) is turned on from off, make sure that this flag is off. Then turn Set value backup instruction (Yn8) off from on. If Set value backup instruction (Yn8) is turned off from on while this flag is on, the L60TC4 operates with the default value since the data in the buffer memory is undefined. Likewise, if the power supply is turned on from off or the CPU module is released from the reset status while this flag is on, the L60TC4 operates with the default value since the data in the buffer memory is undefined.

(9) Setting change completion flag (XnB)

Turning Setting change instruction (YnB) on from off during the setting mode (Setting/operation mode status (Xn1): OFF) reflects the set contents of each buffer memory to the control. After the data is reflected, this flag turns on. Turning Setting change instruction (YnB) off from on also turns off this flag.

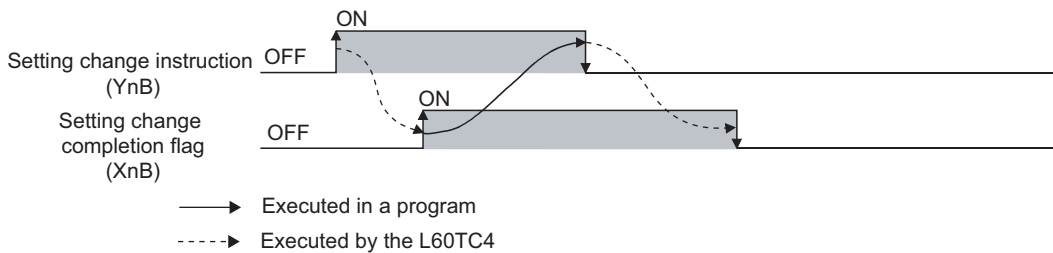

This flag can be used as an interlock condition for Setting/operation mode instruction (Yn1).

(10)CH□ Alert occurrence flag (XnC to XnF)

When an alert occurs, the alert definition is stored in CH□ Alert definition (Un\G5 to Un\G8), and this flag turns on.

For conditions where this flag turns off, refer to the following.

☞ Page 166, Section 8.2.11 (6)

The following table lists the particular flag and buffer memory addresses of alert definitions for each channel.

Channel	Alert occurrence flag	ON/OFF status	CH□ Alert definition (buffer memory address)(☞ Page 336, Appendix 2 (3))
CH1	XnC	OFF: Alert does not occur. ON: Alert occurs.	Un\G5
CH2	XnD		Un\G6
CH3	XnE		Un\G7
CH4	XnF		Un\G8

Ex. Time chart for CH1

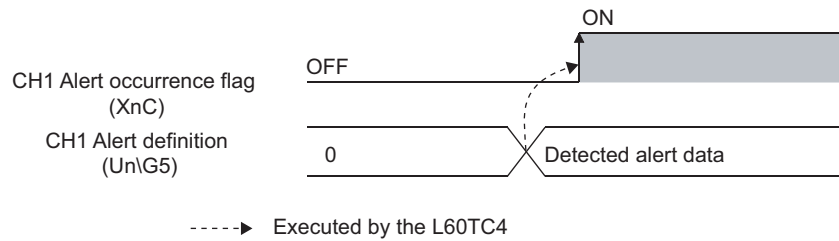

A

Appendix 1 Details of I/O Signals
Appendix 1.1 Input signal

Appendix 1.2 Output signal

(1) Setting/operation mode instruction (Yn1)

Use this signal to select the setting mode or the operation mode.

- OFF: Setting mode
- ON: Operation mode

Some buffer memory areas can be set only in the setting mode.

(a) Buffer memory areas that can be set only in the setting mode

The following settings can be changed only when Setting/operation mode instruction (Yn1) is off. If the settings are changed in the operation mode, a write data error (error code: □□□ 3_H) occurs.

Buffer memory area name	Buffer memory address				Reference
	CH1	CH2	CH3	CH4	
CH□ Input range	Un\G32	Un\G64	Un\G96	Un\G128	Page 345, Appendix 2 (12)
Resolution of the manipulated value for output with another analog module	Un\G181				Page 384, Appendix 2 (48)
CH□ Alert 1 mode setting	Un\G192	Un\G208	Un\G224	Un\G240	Page 386, Appendix 2 (52)
CH□ Alert 2 mode setting	Un\G193	Un\G209	Un\G225	Un\G241	
CH□ Alert 3 mode setting	Un\G194	Un\G210	Un\G226	Un\G242	
CH□ Alert 4 mode setting	Un\G195	Un\G211	Un\G227	Un\G243	
CH□ Process alarm alert output enable/disable setting	Un\G196	Un\G212	Un\G228	Un\G244	Page 387, Appendix 2 (53)
CH□ Process alarm lower lower limit value	Un\G197	Un\G213	Un\G229	Un\G245	Page 388, Appendix 2 (54)
CH□ Process alarm lower upper limit value	Un\G198	Un\G214	Un\G230	Un\G246	
CH□ Process alarm upper lower limit value	Un\G199	Un\G215	Un\G231	Un\G247	
CH□ Process alarm upper upper limit value	Un\G200	Un\G216	Un\G232	Un\G248	
CH□ Rate alarm alert output enable/disable setting	Un\G201	Un\G217	Un\G233	Un\G249	Page 389, Appendix 2 (55)
CH□ Rate alarm alert detection cycle	Un\G202	Un\G218	Un\G234	Un\G250	Page 389, Appendix 2 (56)
CH□ Rate alarm upper limit value	Un\G203	Un\G219	Un\G235	Un\G251	Page 390, Appendix 2 (57)
CH□ Rate alarm lower limit value	Un\G204	Un\G220	Un\G236	Un\G252	
CT□ CT selection	Un\G272 to Un\G279 (set for each current sensor (CT))				Page 392, Appendix 2 (60)
CH□ 2-point sensor compensation offset value (measured value)	Un\G544	Un\G576	Un\G608	Un\G640	Page 394, Appendix 2 (63)
CH□ 2-point sensor compensation offset value (compensation value)	Un\G545	Un\G577	Un\G609	Un\G641	Page 394, Appendix 2 (64)
CH□ 2-point sensor compensation gain value (measured value)	Un\G546	Un\G578	Un\G610	Un\G642	Page 395, Appendix 2 (65)
CH□ 2-point sensor compensation gain value (compensation value)	Un\G547	Un\G579	Un\G611	Un\G643	Page 395, Appendix 2 (66)
CH□ 2-point sensor compensation offset latch request	Un\G548	Un\G580	Un\G612	Un\G644	Page 396, Appendix 2 (67)
CH□ 2-point sensor compensation gain latch request	Un\G550	Un\G582	Un\G614	Un\G646	Page 397, Appendix 2 (69)
Conversion enable/disable setting	Un\G693				Page 402, Appendix 2 (75)
Cooling method setting	Un\G719				Page 404, Appendix 2 (77)
CH□ Process value (PV) scaling function enable/disable setting	Un\G725	Un\G741	Un\G757	Un\G773	Page 405, Appendix 2 (80)

Buffer memory area name	Buffer memory address				Reference
	CH1	CH2	CH3	CH4	
CH□ Process value (PV) scaling lower limit value	Un\G726	Un\G742	Un\G758	Un\G774	Page 406, Appendix 2 (81)
CH□ Process value (PV) scaling upper limit value	Un\G727	Un\G743	Un\G759	Un\G775	
CH□ Derivative action selection	Un\G729	Un\G745	Un\G761	Un\G777	Page 407, Appendix 2 (83)
CH□ Simultaneous temperature rise group setting	Un\G730	Un\G746	Un\G762	Un\G778	Page 407, Appendix 2 (84)
CH□ Setting change rate limiter unit time setting	Un\G735	Un\G751	Un\G767	Un\G783	Page 411, Appendix 2 (89)
Peak current suppression control group setting	Un\G784				Page 412, Appendix 2 (90)
Sensor compensation function selection	Un\G785				Page 413, Appendix 2 (91)

(2) Error reset instruction (Yn2)

Use this signal to turn off Error occurrence flag (Xn2) and to reset Error code (Un\G0). For the method to reset an error, refer to Error occurrence flag (Xn2). (☞ Page 325, Appendix 1.1 (3))

(3) CH□ Auto tuning instruction (Yn4 to Yn7)

Use this signal to start auto tuning. Turning this signal on from off starts auto tuning and turns on CH□ Auto tuning status (Xn4 to Xn7). After auto tuning is completed, CH□ Auto tuning status (Xn4 to Xn7) turns off. Keep this instruction ON during auto tuning and turn it off from on at the completion of the auto tuning. If this instruction is turned off from on during auto tuning, the auto tuning stops. If the auto tuning stops, PID constants in the buffer memory do not change.

Point

- If proportional band (P)/heating proportional band (Ph) is set to 0, auto tuning cannot be performed. (☞ Page 355, Appendix 2 (15))
- If Setting/operation mode instruction (Yn1) is turned off from on and the operation status shifts to the setting mode during auto tuning, the auto tuning stops. After that, even if Setting/operation mode instruction (Yn1) is turned on from off and the the operation status shifts back to the operation mode, the auto tuning does not resume. To resume the auto tuning, turn Auto tuning instruction (Yn4 to Yn7) off from on, and turn it on from off again.

For details on the auto tuning function, refer to the following.

☞ Page 141, Section 8.2.7

(4) Set value backup instruction (Yn8)

Use this signal to write the buffer memory data to the non-volatile memory. Turning this instruction on from off starts the data writing to the non-volatile memory.

For the buffer memory areas whose data is to be backed up, refer to the following.

 Page 44, Section 3.5

(a) When data writing to the non-volatile memory has completed normally

Back-up of the set value completion flag (Xn8) turns on.

(b) When data writing to the non-volatile memory has not completed normally

Back-up of the set value fail flag (XnA) turns on. When Back-up of the set value fail flag (XnA) turns on, turn Set value backup instruction (Yn8) on from off to write the data to the non-volatile memory again.

(c) Timings when this instruction cannot be received

In the following timings, this instruction cannot be received.

- 1: While PID constants are written after auto tuning
- 2: While PID constants are read from the non-volatile memory
- 3: While a setting error is occurring
- 4: While a setting is being changed by Setting change instruction (YnB)

For 1 to 3 above, turn this instruction on from off after each condition is resolved. For 4, the data writing to the non-volatile memory automatically starts after the condition is resolved.

For details on the data writing to the non-volatile memory, refer to the following.

 Page 235, Section 8.3.4

(5) Default setting registration instruction (Yn9)

Use this signal to set data in the buffer memory or the non-volatile memory back to the default value.

Turning this instruction on from off starts the writing of the default value of the L60TC4 to the buffer memory.

After the data writing is completed, Default value write completion flag (Xn9) turns on.

(a) When Setting/operation mode status (Xn1) is on (in operation mode)

Turning this instruction on from off does not set data back to the default value. Turn on this instruction when Setting/operation mode status (Xn1) is off (in the setting mode).

(6) Setting change instruction (YnB)

Use this instruction to confirm the set value of the buffer memory (the buffer memory areas that can be set only in the setting mode (Setting/operation mode status (Xn1): OFF). ( Page 330, Appendix 1.2 (1))

(a) Reflection of set value

Even though the set values are written into the buffer memory, they cannot be reflected to the L60TC4's operation immediately. To confirm the set values, turn this instruction OFF → ON → OFF after the set values are written into the buffer memory. Doing so lets the L60TC4 operate according to the setting in each buffer memory area.

(7) CH□ PID control forced stop instruction (YnC to YnF)

Use this signal to temporarily stop PID control forcibly.

(a) Mode when PID control stops

The mode depends on the setting of CH□ Stop mode setting (Un\G33, Un\G65, Un\G97, Un\G129).

For details on CH□ Stop mode setting (Un\G33, Un\G65, Un\G97, Un\G129), refer to the following.

 Page 353, Appendix 2 (13)

Appendix 2 Details of the Buffer Memory

This chapter describes details on the buffer memory of the L60TC4.

Point

For buffer memory areas indicated with the icons **Standard** and **Heating-cooling**, or with **Common**, the following terms are used, unless otherwise specified.

- Proportional band (P): includes heating proportional band (Ph) and cooling proportional band (Pc)
- Manipulated value (MV): includes manipulated value for heating (MVh) and manipulated value for cooling (MVc).
- Transistor output: includes heating transistor output and cooling transistor output
- Control output cycle: includes heating control output cycle and cooling control output cycle

(1) Error code (Un\G0) **Common**

An error code or alarm code is stored in this buffer memory area.

For error codes and alarm codes, refer to the following.

 Page 315, Section 11.6, Page 318, Section 11.7

(2) CH□ Decimal point position (Un\G1 to Un\G4) **Common**

According to the setting of CH□ Input range (Un\G32, Un\G64, Un\G96, Un\G128), the decimal point position applicable in the following buffer memory areas is stored in this buffer memory area.

Buffer memory area name	Buffer memory address				Reference
	CH1	CH2	CH3	CH4	
CH□ Temperature process value (PV)	Un\G9	Un\G10	Un\G11	Un\G12	Page 338, Appendix 2 (4)
CH□ Set value (SV) setting	Un\G34	Un\G66	Un\G98	Un\G130	Page 354, Appendix 2 (14)
CH□ Alert set value 1	Un\G38	Un\G70	Un\G102	Un\G134	Page 358, Appendix 2 (18)
CH□ Alert set value 2	Un\G39	Un\G71	Un\G103	Un\G135	
CH□ Alert set value 3	Un\G40	Un\G72	Un\G104	Un\G136	
CH□ Alert set value 4	Un\G41	Un\G73	Un\G105	Un\G137	
CH□ AT bias setting	Un\G53	Un\G85	Un\G117	Un\G149	Page 370, Appendix 2 (29)
CH□ Upper limit setting limiter	Un\G55	Un\G87	Un\G119	Un\G151	Page 372, Appendix 2 (31)
CH□ Lower limit setting limiter	Un\G56	Un\G88	Un\G120	Un\G152	
CH□ Loop disconnection detection dead band	Un\G60	Un\G92	Un\G124	Un\G156	Page 375, Appendix 2 (34)
CH□ Process alarm lower lower limit value	Un\G197	Un\G213	Un\G229	Un\G245	Page 388, Appendix 2 (54)
CH□ Process alarm lower upper limit value	Un\G198	Un\G214	Un\G230	Un\G246	
CH□ Process alarm upper lower limit value	Un\G199	Un\G215	Un\G231	Un\G247	
CH□ Process alarm upper upper limit value	Un\G200	Un\G216	Un\G232	Un\G248	
CH□ Rate alarm upper limit value	Un\G203	Un\G219	Un\G235	Un\G251	Page 390, Appendix 2 (57)
CH□ Rate alarm lower limit value	Un\G204	Un\G220	Un\G236	Un\G252	
CH□ 2-point sensor compensation offset value (measured value)	Un\G544	Un\G576	Un\G608	Un\G640	Page 394, Appendix 2 (63)
CH□ 2-point sensor compensation offset value (compensation value)	Un\G545	Un\G577	Un\G609	Un\G641	Page 394, Appendix 2 (64)

Buffer memory area name	Buffer memory address				Reference
	CH1	CH2	CH3	CH4	
CH□ 2-point sensor compensation gain value (measured value)	Un\G546	Un\G578	Un\G610	Un\G642	Page 395, Appendix 2 (65)
CH□ 2-point sensor compensation gain value (compensation value)	Un\G547	Un\G579	Un\G611	Un\G643	Page 395, Appendix 2 (66)
CH□ Simultaneous temperature rise gradient data	Un\G731	Un\G747	Un\G763	Un\G779	Page 408, Appendix 2 (85)

Stored values differ depending on the setting in CH□ Input range (Un\G32, Un\G64, Un\G96, Un\G128).

Setting of CH□ Input range (Un\G32, Un\G64, Un\G96, Un\G128) ( Page 345, Appendix 2 (12))	Stored value	Setting contents
Resolution is 1.	0	Nothing after decimal point
Resolution is 0.1.	1	First decimal place

A

(3) CH□ Alert definition (Un\G5 to Un\G8) Common

Bits corresponding to alerts detected in each channel become 1.

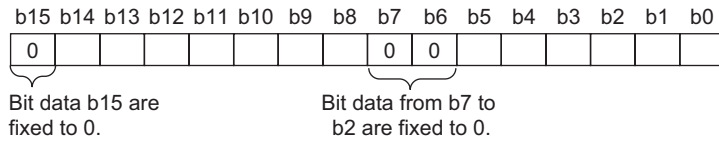

Target bit number	Flag name	Alert definition
b0	CH□ Input range upper limit	Temperature process value (PV) has exceeded the temperature measurement range* ¹ of the set input range.
b1	CH□ Input range lower limit	Temperature process value (PV) has fallen below the temperature measurement range* ¹ of the set input range.
b2	CH□ Process alarm upper limit	Temperature process value (PV) has reached the process alarm upper upper limit value or more.
b3	CH□ Process alarm lower limit	Temperature process value (PV) has reached the process alarm lower lower limit value or lower.
b4	CH□ Rate alarm upper limit	The variation of temperature process value (PV) has reached the rate alarm upper limit value or more.
b5	CH□ Rate alarm lower limit	The variation of temperature process value (PV) has reached the rate alarm lower limit value or lower.
b6 to b7	— (fixed to 0)	— (Unused)
b8	CH□ Alert 1	Alert 1 has occurred. (☞ Page 157, Section 8.2.11)
b9	CH□ Alert 2	Alert 2 has occurred. (☞ Page 157, Section 8.2.11)
b10	CH□ Alert 3	Alert 3 has occurred. (☞ Page 157, Section 8.2.11)
b11	CH□ Alert 4	Alert 4 has occurred. (☞ Page 157, Section 8.2.11)
b12	CH□ Heater disconnection detection	Heater disconnection has been detected. (☞ Page 215, Section 8.2.24)
b13	CH□ Loop disconnection detection	Loop disconnection has been detected. (☞ Page 204, Section 8.2.19)
b14	CH□ Output off-time current error	Output off-time current error has been detected. (☞ Page 220, Section 8.2.25)
b15	— (fixed to 0)	— (Unused)

*1 For the temperature measurement range, refer to Page 337, Appendix 2 (3) (a).

(a) Temperature measurement range

The temperature measurement range is as follows.

- Input range lower limit - 5% of full scale to Input range upper limit + 5% of full scale

Ex. A calculation example when CH□ Input range (Un\G32, Un\G64, Un\G96, Un\G128): 38
(temperature measurement range: -200.0 to 400.0°C)

- Input range lower limit - 5% of full scale = $-200 - ((400.0 - (-200.0)) \times 0.05) = -230.0$
- Input range upper limit + 5% of full scale = $400 + ((400.0 - (-200.0)) \times 0.05) = 430.0$

Therefore, the temperature measurement range is -230.0 to 430.0°C.

The L60TC4 checks whether the input temperature is in temperature measurement range of the input range. When the input temperature is out of the temperature measurement range, CH□ Input range upper limit (b0 of Un\G5 to Un\G8), or CH□ Input range lower limit (b1 of Un\G5 to Un\G8) becomes 1 (ON). The conditions which the L60TC4 uses to judge whether the measured temperature is within the temperature measurement range differ depending on the following settings.

- Setting/operation mode instruction (Yn1) (☞ Page 330, Appendix 1.2 (1))
- PID continuation flag (Un\G169) (☞ Page 381, Appendix 2 (43))
- CH□ PID control forced stop instruction (YnC to YnF) (☞ Page 333, Appendix 1.2 (7))
- CH□ Stop mode setting (Un\G33, Un\G65, Un\G97, Un\G129) (☞ Page 353, Appendix 2 (13))

Point

The following table lists the conditions whether to perform the temperature judgment.

○: Executed ×: Not executed

Setting/operation mode instruction (Yn1)*1	PID continuation flag (Un\G169)	CH□ PID control forced stop instruction (YnC to YnF)	CH□ Stop mode setting (Un\G33, Un\G65, Un\G97, Un\G129)	Temperature judgment	
Setting mode at power-ON	Stop (0)/Continue (1)	OFF/ON	Stop (0)	×	
			Monitor (1)	○	
			Alert (2)	○	
Operation mode (in operation)	Stop (0)/Continue (1)	OFF	Stop (0)/Monitor (1)/Alert (2)	○	
		ON	Stop (0)	×	
			Monitor (1)	○	
Setting mode (after operation)	Stop (0)	OFF/ON	Alert (2)	○	
			Stop (0)	×	
			Monitor (1)	○	
	Continue (1)	OFF	Stop (0)/Monitor (1)/Alert (2)	○	
			ON	Stop (0)	×
				Monitor (1)	○
			Alert (2)	○	

*1 Refer to ☞ Page 324, Appendix 1.1 (2) for each timing.

If CH□ Unused channel setting (Un\G61, Un\G93, Un\G125, Un\G157) is set to Disable (1), temperature judgment is not executed even though the condition above is satisfied. (☞ Page 376, Appendix 2 (35))

(4) CH□ Temperature process value (PV) (Un\G9 to Un\G12) Common

The detected temperature value where sensor correction is performed is stored in this buffer memory area.

The value to be stored differs depending on the stored value in CH□ Decimal point position (Un\G1 to Un\G4).

(☞ Page 334, Appendix 2 (2))

- No decimal place (0): Stored as it is.
- One decimal place (1): Stored after a multiplication by 10.

Point

When value measured by a temperature sensor exceeds the temperature measurement range, the following value is stored.

- When measured value exceeds temperature measurement range: Input range upper limit + 5% of full scale
 - When measured value falls below temperature measurement range: Input range lower limit - 5% of full scale
-

(5) CH□ Manipulated value (MV) (Un\G13 to Un\G16) Standard

CH□ Manipulated value for heating (MVh) (Un\G13 to Un\G16) Heating-cooling

CH□ Manipulated value for cooling (MVc) (Un\G704 to Un\G707) Heating-cooling

The result of PID operation based on temperature process value (PV) is stored in these buffer memory areas. The area Un\G13 to Un\G16 are used for heating in the case of the heating-cooling control. The following table lists the range of values to be stored.

Store description	Store range in control	Stored value when control stops
Manipulated value (MV)	-50 to 1050 (-5% to 105.0%)	-50 (-5.0%)
Manipulated value for heating (MVh)	0 to 1050 (0.0% to 105.0%)	-50 (-5.0%)
Manipulated value for cooling (MVc)		

However, values are output in the range of 0% to 100%. For 0% or less and 100% or more, refer to the following.

- For 0% or less: 0%
- For 100% or more: 100%

(a) Manipulated value (MV) and control output cycle

- Manipulated value (MV) indicates ON time of CH□ Control output cycle setting (Un\G47, Un\G79, Un\G111, Un\G143) in percentage. (☞ Page 364, Appendix 2 (23))
- Manipulated value for heating (MVh) indicates ON time of CH□ Heating control output cycle setting (Un\G47, Un\G79, Un\G111, Un\G143) in percentage. (☞ Page 364, Appendix 2 (23))
- Manipulated value for cooling (MVc) indicates ON time of CH□ Cooling control output cycle setting (Un\G722, Un\G738, Un\G754, Un\G770) in percentage. (☞ Page 364, Appendix 2 (23))

Ex. When 600 (60.0%) is stored in CH□ Manipulated value (MV) (Un\G13 to Un\G16) and the value of the buffer memory is set as shown in the following.

- CH□ Control output cycle setting (Un\G47, Un\G79, Un\G111, Un\G143): 30s
 ON time of transistor output = Control output cycle setting (s) × Manipulated value (MV) (%) = 30 × 0.6 = 18 (s)
 ON time of transistor output is 18s.
 Transistor output is pulse of ON for 18s, OFF for 12s.

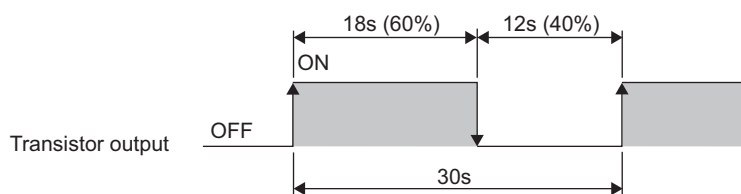

A

Appendix 2 Details of the Buffer Memory

(6) CH□ Temperature rise judgment flag (Un\G17 to Un\G20) Standard Heating-cooling

This flag is for checking whether the temperature process value (PV) is in the temperature rise completion range or not.

The following values are stored in this buffer memory area.

- 0: Out of temperature rise completion range
- 1: Within temperature rise completion range

When the temperature process value (PV) stays in the temperature rise completion range during the set temperature rise completion soak time, 1 is stored in this buffer memory area, which is within temperature rise completion range (1).

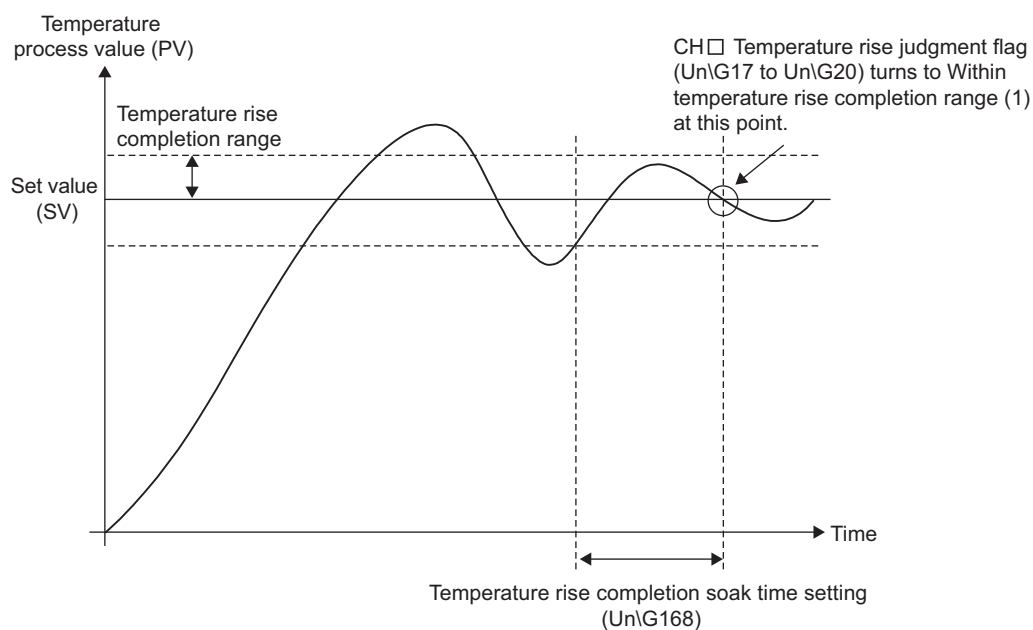

Set the temperature rise completion range and temperature rise completion soak time in the following buffer memory areas.

- Temperature rise completion range setting (Un\G167) (☞ Page 380, Appendix 2 (41))
- Temperature rise completion soak time setting (Un\G168) (☞ Page 381, Appendix 2 (42))

(7) CH Transistor output flag (Un\G21 to Un\G24) Standard

CH Heating transistor output flag (Un\G21 to Un\G24) Heating-cooling

CH Cooling transistor output flag (Un\G712 to Un\G715) Heating-cooling

ON/OFF status of transistor output and ON delay output are stored in these flags. In the heating-cooling control, ON/OFF status of transistor output/ON delay output for heating are stored in Un\G21 to Un\G24.

- OFF: 0
- ON: 1

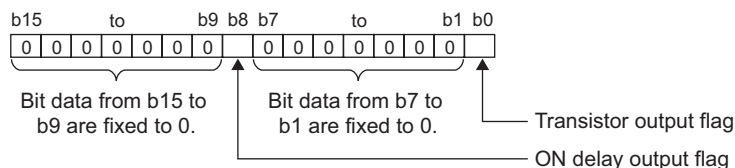

(a) Relationship with ON delay output flag

Relationship between Transistor output flag and ON delay output flag is shown in the following.

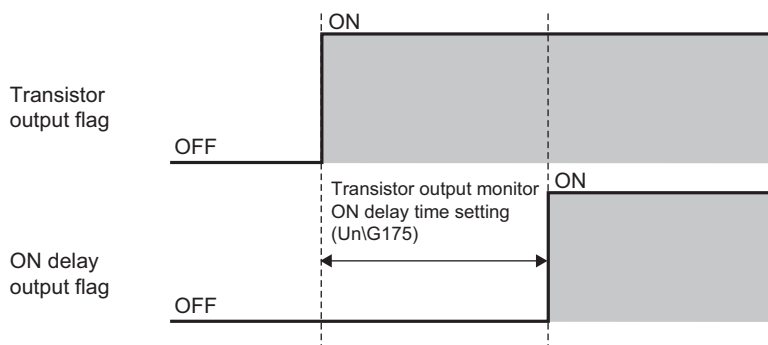

Transistor output monitor ON delay time setting (Un\G175) enables setting considering delay time (response/scan time delay) of actual transistor output. (Page 382, Appendix 2 (45)) By monitoring the ON delay output flag and external output on the program, disconnection of external output can be judged.

For details on the ON delay output function, refer to the following.

Page 174, Section 8.2.14

A

Appendix 2 Details of the Buffer Memory

(8) CH□ Set value (SV) monitor (Un\G25 to Un\G28) Standard Heating-cooling

Set value (SV) of each time unit set in CH□ Setting change rate limiter time unit setting (Un\G735, Un\G751, Un\G767, Un\G783) is stored in this buffer memory area. (☞ Page 411, Appendix 2 (89))
The set value (SV) can be monitored in real time.

(9) Cold junction temperature process value (Un\G29) Common

The measured temperature of cold junction temperature compensation resistor is stored in this buffer memory area.

Values to be stored are within 0 to 55°C.

(a) Usable modules

- L60TCTT4
- L60TCTT4BW

(10) MAN mode shift completion flag (Un\G30) Standard Heating-cooling

This flag is for checking completion of the mode shift when shifting AUTO (auto) mode to MAN (manual) mode. The following values are stored in this buffer memory area.

- 0: MAN mode shift uncompleted
- 1: MAN mode shift completed

The following figure shows bits of the buffer memory area that correspond to each channel.

b15	b14	b13	b12	b11	b10	b9	b8	b7	b6	b5	b4	b3	b2	b1	b0
0	0	0	0	0	0	0	0	0	0	0	0	CH4	CH3	CH2	CH1

Bit data from b15 to b4 are fixed to 0.

When shift to MAN mode is completed, bits corresponding to appropriate channel become MAN mode shift completed (1).

(a) How to shift the mode

Shift the mode in the following buffer memory area.

- CH□ AUTO/MAN mode shift (Un\G50, Un\G82, Un\G114, Un\G146) (☞ Page 367, Appendix 2 (26))

(b) Setting manipulated value (MV) in MAN mode

Set the manipulated value (MV) in the following buffer memory area.

- CH□ MAN output setting (Un\G51, Un\G83, Un\G115, Un\G147) (☞ Page 368, Appendix 2 (27))

Set the manipulated value (MV) after confirming MAN mode shift completion flag (Un\G30) has become MAN mode shift completed (1).

(11)Memory of PID constants read/write completion flag (Un\G31) Standard Heating-cooling

This flag is for showing whether the settings of the following buffer memory areas are completed or not.

- CH□ Memory of PID constants read instruction (Un\G62, Un\G94, Un\G126, Un\G158) (☞ Page 377, Appendix 2 (36))
- CH□ Automatic backup setting after auto tuning of PID constants (Un\G63, Un\G95, Un\G127, Un\G159) (☞ Page 378, Appendix 2 (37))

(a) Correspondence between each bit and flag

The following table lists flags correspond to bits of this buffer memory area.

Bit number	Flag description	Bit number	Flag description
b0	CH1 Read completion flag	b8	CH1 Read failure flag
b1	CH2 Read completion flag	b9	CH2 Read failure flag
b2	CH3 Read completion flag	b10	CH3 Read failure flag
b3	CH4 Read completion flag	b11	CH4 Read failure flag
b4	CH1 Write completion flag	b12	CH1 Write failure flag
b5	CH2 Write completion flag	b13	CH2 Write failure flag
b6	CH3 Write completion flag	b14	CH3 Write failure flag
b7	CH4 Write completion flag	b15	CH4 Write failure flag

(b) ON/OFF timing for CH□ Memory of PID constants read instruction (Un\G62, Un\G94, Un\G126, Un\G158) (☞ Page 377, Appendix 2 (36))

The following figure shows the ON/OFF timing of this flag for CH□ Memory of PID constants read instruction (Un\G62, Un\G94, Un\G126, Un\G158). (For CH1)

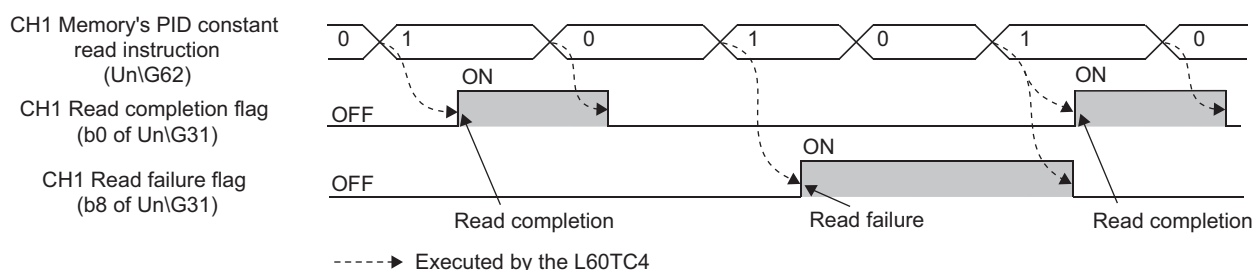

When the data reading from the non-volatile memory is completed normally, CH□ Read completion flag (b0 to b3 of Un\G31) of the corresponding channel turns on.

CH□ Read completion flag (b0 to b3 of Un\G31) turns off when CH□ Memory of PID constants read instruction (Un\G62, Un\G94, Un\G126, Un\G158) is turned off from on.

When the data reading from the non-volatile memory fails, CH□ Read failure flag (b8 to b11 of Un\G31) of the corresponding channel turns on and the L60TC4 operates with PID constants before the data reading. (The LED status remains.)

CH□ Read failure flag (b8 to b11 of Un\G31) turns off when the data reading of the corresponding channel is completed normally.

When the data reading fails, try again by turning CH□ Memory of PID constants read instruction (Un\G62, Un\G94, Un\G126, Un\G158) ON → OFF → ON.

(c) ON/OFF timing for CH□ Automatic backup setting after auto tuning of PID constants (Un\G63, Un\G95, Un\G127, Un\G159) (☞ Page 378, Appendix 2 (37))

The following figure shows ON/OFF timing of this flag for CH□ Automatic backup setting after auto tuning of PID constants (Un\G63, Un\G95, Un\G127, Un\G159). (For CH1)

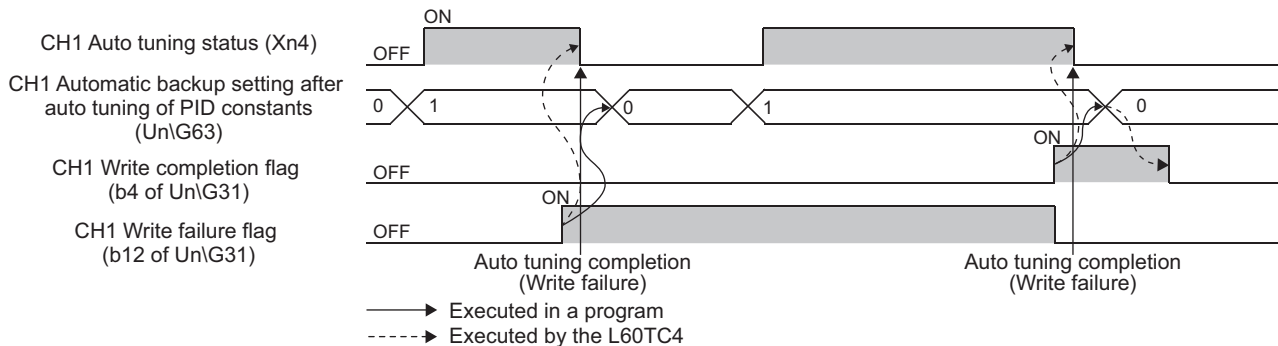

When the data writing to the non-volatile memory is completed normally, CH□ Write completion flag (b4 to b7 of Un\G31) turns on.

CH□ Write completion flag (b4 to b7 of Un\G31) turns off when CH□ Automatic backup setting after auto tuning of PID constants (Un\G63, Un\G95, Un\G127, Un\G159) is set to Disable (0) from Enable (1).

When the data writing to the non-volatile memory fails, CH□ Write failure flag (b12 to b15 of Un\G31) of the corresponding channel turns on and the L60TC4 operates with PID constants calculated in the previous auto tuning. (The LED status remains.)

CH□ Write failure flag (b12 to b15 of Un\G31) turns off when the data writing of the corresponding channel is completed normally.

When the data writing fails, perform auto tuning again by turning CH□ Auto tuning instruction (Yn4 to Yn7) ON → OFF → ON. If the data writing fails even after executing auto tuning again, a hardware error can be the reason. Consult a local representative or branch about the problem.

Point

- By referring to this flag at the completion of auto tuning, whether the automatic data backup is completed normally or not can be checked.
- After confirming that the following flags are on, set CH□ Automatic backup setting after auto tuning of PID constants (Un\G63, Un\G95, Un\G127, Un\G159) to Disable (0).
 - CH□ Write completion flag (b4 to b7 of Un\G31) (when automatic data backup is completed normally)
 - CH□ Write failure flag (b12 to b15 of Un\G31) (when automatic data backup fails)
 If auto tuning is executed under Enable (1), although PID constants are stored after auto tuning is complete, CH□ Auto tuning status (Xn4 to Xn7) does not turn off.

For details on the auto tuning function, refer to the following.

☞ Page 141, Section 8.2.7

(12)CH□ Input range (Un\G32, Un\G64, Un\G96, Un\G128) Common

Select the set value according to temperature sensor, temperature measurement range^{*1}, output temperature unit (Celsius (°C)/Fahrenheit (°F)/digit) and resolution (1/0.1) which are used with the L60TC4.

*1 In the case of input from other analog modules (such as an A/D converter module) also, set these values.

Ex. When the L60TCTT4 or L60TCTT4BW is used and the following thermocouple is selected

- Thermocouple type: R
- Temperature measurement range: 0 to 1700°C
- Resolution: 1

Set 1 in CH□ Input range (Un\G32, Un\G64, Un\G96, Un\G128).

When using the L60TCTT4 or L60TCTT4BW, refer to  Page 346, Appendix 2 (12) (a).

When using the L60TCRT4 or L60TCRT4BW, refer to  Page 350, Appendix 2 (12) (b).

(a) Setting range of the L60TCTT4, L60TCTT4BW

The following table lists setting values of CH□ Input range (Un\G32, Un\G64, Un\G96, Un\G128) and the corresponding thermocouple types.

The relationship between temperature unit and setting values is as follows.

Setting of CH□ Input range (Un\G32, Un\G64, Un\G96, Un\G128)	Item	
1 to 99	Thermocouple is used. (No input from other analog modules (such as an A/D converter module)) (1 to 199)	Output temperature unit is Celsius (°C).
100 to 199		Output temperature unit is Fahrenheit (°F).
200 to 299	Other analog modules (such as an A/D converter module) are used. (200 to 299)	Unit is digit.

Thermocouple type	Temperature measurement range	Celsius (°C)/ Fahrenheit (°F)/digit	Resolution	CH□ Input range (Un\G32, Un\G64, Un\G96, Un\G128)	Automatic setting when changing the input range *1	
					CH□ Upper limit setting limiter, CH□ Process alarm upper lower limit value, CH□ Process alarm upper upper limit value	CH□ Lower limit setting limiter, CH□ Process alarm lower lower limit value, CH□ Process alarm lower upper limit value
R	0 to 1700	°C	1	1	1700	0
	0 to 3000	°F	1	105	3000	0
K	-200.0 to 400.0	°C	0.1	38	4000	-2000
	0.0 to 400.0	°C	0.1	36	4000	0
	0 to 1300	°C	1	2 (Default value)	1300	0
	0 to 500	°C	1	11	500	0
	0.0 to 500.0	°C	0.1	40	5000	0
	0 to 800	°C	1	12	800	0
	0.0 to 800.0	°C	0.1	41	8000	0
	-200.0 to 1300.0	°C	0.1	49	13000	-2000
	0 to 1000	°F	1	100	1000	0
	0.0 to 1000.0	°F	0.1	130	10000	0
	0 to 2400	°F	1	101	2400	0

Thermocouple type	Temperature measurement range	Celsius (°C)/ Fahrenheit (°F)/digit	Resolution	CH□ Input range (Un\G32, Un\G64, Un\G96, Un\G128)	Automatic setting when changing the input range*1	
					CH□ Upper limit setting limiter, CH□ Process alarm upper lower limit value, CH□ Process alarm upper upper limit value	CH□ Lower limit setting limiter, CH□ Process alarm lower lower limit value, CH□ Process alarm lower upper limit value
J	0.0 to 400.0	°C	0.1	37	4000	0
	0 to 500	°C	1	13	500	0
	0.0 to 500.0	°C	0.1	42	5000	0
	0 to 800	°C	1	14	800	0
	0.0 to 800.0	°C	0.1	43	8000	0
	-200.0 to 1000.0	°C	0.1	50	10000	-2000
	0 to 1200	°C	1	3	1200	0
	0 to 1000	°F	1	102	1000	0
	0.0 to 1000.0	°F	0.1	131	10000	0
	0 to 1600	°F	1	103	1600	0
	0 to 2100	°F	1	104	2100	0
T	-200 to 400	°C	1	4	400	-200
	-200 to 200	°C	1	21	200	-200
	-200.0 to 400.0	°C	0.1	39	4000	-2000
	0 to 200	°C	1	19	200	0
	0 to 400	°C	1	20	400	0
	0.0 to 400.0	°C	0.1	45	4000	0
	-300 to 400	°F	1	110	400	-300
	0 to 700	°F	1	109	700	0
S	0 to 1700	°C	1	15	1700	0
	0 to 3000	°F	1	106	3000	0
B	0 to 1800	°C	1	16	1800	0
	0 to 3000	°F	1	107	3000	0
E	0 to 400	°C	1	17	400	0
	0.0 to 700.0	°C	0.1	44	7000	0
	0 to 1000	°C	1	18	1000	0
	-200.0 to 1000.0	°C	0.1	51	10000	-2000
	0 to 1800	°F	1	108	1800	0
N	0 to 1300	°C	1	22	1300	0
	0.0 to 1000.0	°C	0.1	52	10000	0
	0 to 2300	°F	1	111	2300	0

A

Thermocouple type	Temperature measurement range	Celsius (°C)/ Fahrenheit (°F)/digit	Resolution	CH□ Input range (Un\G32, Un\G64, Un\G96, Un\G128)	Automatic setting when changing the input range*1	
					CH□ Upper limit setting limiter, CH□ Process alarm upper lower limit value, CH□ Process alarm upper upper limit value	CH□ Lower limit setting limiter, CH□ Process alarm lower lower limit value, CH□ Process alarm lower upper limit value
U	-200 to 200	°C	1	26	200	-200
	0 to 400	°C	1	25	400	0
	0.0 to 600.0	°C	0.1	46	6000	0
	-300 to 400	°F	1	115	400	-300
	0 to 700	°F	1	114	700	0
L	0 to 400	°C	1	27	400	0
	0.0 to 400.0	°C	0.1	47	4000	0
	0 to 900	°C	1	28	900	0
	0.0 to 900.0	°C	0.1	48	9000	0
	0 to 800	°F	1	116	800	0
PLII	0 to 1600	°F	1	117	1600	0
	0 to 1200	°C	1	23	1200	0
W5Re/W26Re	0 to 2300	°C	1	24	2300	0
	0 to 3000	°F	1	113	3000	0
Input from other analog modules (0 to 4000)*2	0 to 4000	digit	1	201	4000	0
Input from other analog modules (0 to 12000)*2	0 to 12000	digit	1	202	12000	0
Input from other analog modules (0 to 16000)*2	0 to 16000	digit	1	203	16000	0
Input from other analog modules (0 to 20000)*2	0 to 20000	digit	1	204	20000	0
Input from other analog modules (0 to 32000)*2	0 to 32000	digit	1	205	32000	0

*1 When the input range is changed, the set values in some buffer memory areas are initialized automatically and return to the default value (0).

(☞ Page 351, Appendix 2 (12) (d))

*2 Same as the L60TCRT4, L60TCRT4BW

Remark

For the following mode and channel, CH□ Input range (Un\G32, Un\G64, Un\G96, Un\G128) cannot be set to 201 to 205. If these values are set, a write data error (error code: □□□4_H) occurs.

Mode		Corresponding channel
Temperature input mode		CH1 to CH4
Temperature control mode	Heating-cooling control (normal mode)	CH3, CH4
	Mix control (normal mode)	CH2

A

(b) Setting range of the L60TCRT4, L60TCRT4BW

The following table lists setting values of CH□ Input range (Un\G32, Un\G64, Un\G96, Un\G128) and the corresponding platinum resistance thermometer types.

Platinum resistance thermometer type	Temperature measurement range	Celsius (°C)/ Fahrenheit (°F)/digit	Resolution	CH□ Input range (Un\G32, Un\G64, Un\G96, Un\G128)	Automatic setting when changing the input range*1	
					CH□ Upper limit setting limiter, CH□ Process alarm upper lower limit value, CH□ Process alarm upper upper limit value	CH□ Lower limit setting limiter, CH□ Process alarm lower lower limit value, CH□ Process alarm lower upper limit value
Pt100	-200.0 to 600.0	°C	0.1	7 (Default value)	6000	-2000
	-200.0 to 200.0	°C	0.1	8	2000	-2000
	-200.0 to 850.0	°C	0.1	54	8500	-2000
	-300 to 1100	°F	1	141	1100	-300
	-300.0 to 300.0	°F	0.1	143	3000	-3000
JPt100	-200.0 to 500.0	°C	0.1	5	5000	-2000
	-200.0 to 200.0	°C	0.1	6	2000	-2000
	-200.0 to 640.0	°C	0.1	53	6400	-2000
	-300 to 900	°F	1	140	900	-300
	-300.0 to 300.0	°F	0.1	142	3000	-3000
Input from other analog modules (0 to 4000)*2	0 to 4000	digit	1	201	4000	0
Input from other analog modules (0 to 12000)*2	0 to 12000	digit	1	202	12000	0
Input from other analog modules (0 to 16000)*2	0 to 16000	digit	1	203	16000	0
Input from other analog modules (0 to 20000)*2	0 to 20000	digit	1	204	20000	0
Input from other analog modules (0 to 32000)*2	0 to 32000	digit	1	205	32000	0

*1 When the input range is changed, the set values in some buffer memory areas are initialized automatically and return to the default value (0).

(Page 351, Appendix 2 (12) (d))

*2 Same as the L60TCTT4, L60TCTT4BW

Remark

For the following mode and channel, CH□ Input range (Un\G32, Un\G64, Un\G96, Un\G128) cannot be set to 201 to 205. If these values are set, a write data error (error code: □□□4_H) occurs.

Mode		Corresponding channel
Temperature input mode		CH1 to CH4
Temperature control mode	Heating-cooling control (normal mode)	CH3, CH4
	Mix control (normal mode)	CH2

(c) Resolution

The resolution is applied to the stored values and the set values of particular buffer memory areas as described in the following table.

Resolution	Stored value	Set value
1	Value in 1°C (°F or digit) unit is stored.	Set a value in 1°C (°F or digit) unit.
0.1	Value in 0.1°C (°F) unit (tenfold value) is stored.	Set a value in 0.1°C (°F) unit (tenfold value).

For applicable buffer memory areas, refer to the following.

 Page 334, Appendix 2 (2)

(d) When "Auto-setting at Input Range Change" is set to "1: Enable" on Switch Setting

 Page 108, Section 7.2

When the input range is changed, the following buffer memory areas are set automatically according to selected temperature sensor. Set the buffer memory areas again if necessary.

Buffer memory area name	Buffer memory address				Reference
	CH1	CH2	CH3	CH4	
CH□ Upper limit setting limiter	Un\G55	Un\G87	Un\G119	Un\G151	Page 372, Appendix 2 (31)
CH□ Lower limit setting limiter	Un\G56	Un\G88	Un\G120	Un\G152	
CH□ Process alarm lower lower limit value	Un\G197	Un\G213	Un\G229	Un\G245	Page 388, Appendix 2 (54)
CH□ Process alarm lower upper limit value	Un\G198	Un\G214	Un\G230	Un\G246	
CH□ Process alarm upper lower limit value	Un\G199	Un\G215	Un\G231	Un\G247	
CH□ Process alarm upper upper limit value	Un\G200	Un\G216	Un\G232	Un\G248	

At the same time, the following buffer memory areas related to the input range is initialized to the default value (0) automatically. Set the buffer memory areas again if necessary.

Buffer memory area name	Buffer memory address				Reference
	CH1	CH2	CH3	CH4	
CH□ Set value (SV) setting	Un\G34	Un\G66	Un\G98	Un\G130	Page 354, Appendix 2 (14)
CH□ Alert set value 1	Un\G38	Un\G70	Un\G102	Un\G134	Page 358, Appendix 2 (18)
CH□ Alert set value 2	Un\G39	Un\G71	Un\G103	Un\G135	
CH□ Alert set value 3	Un\G40	Un\G72	Un\G104	Un\G136	
CH□ Alert set value 4	Un\G41	Un\G73	Un\G105	Un\G137	
CH□ AT bias setting	Un\G53	Un\G85	Un\G117	Un\G149	Page 370, Appendix 2 (29)
CH□ Loop disconnection detection dead band	Un\G60	Un\G92	Un\G124	Un\G156	Page 375, Appendix 2 (34)
CH□ 2-point sensor compensation offset value (measured value)	Un\G544	Un\G576	Un\G608	Un\G640	Page 394, Appendix 2 (63)

Buffer memory area name	Buffer memory address				Reference
	CH1	CH2	CH3	CH4	
CH□ 2-point sensor compensation offset value (compensation value)	Un\G545	Un\G577	Un\G609	Un\G641	Page 394, Appendix 2 (64)
CH□ 2-point sensor compensation gain value (measured value)	Un\G546	Un\G578	Un\G610	Un\G642	Page 395, Appendix 2 (65)
CH□ 2-point sensor compensation gain value (compensation value)	Un\G547	Un\G579	Un\G611	Un\G643	Page 395, Appendix 2 (66)
CH□ Simultaneous temperature rise gradient data	Un\G731	Un\G747	Un\G763	Un\G779	Page 408, Appendix 2 (85)
CH□ Simultaneous temperature rise dead time	Un\G732	Un\G748	Un\G764	Un\G780	Page 408, Appendix 2 (86)

These 19 buffer memory areas are set automatically when the input range is changed and Setting change instruction (YnB) is turned OFF → ON → OFF during setting mode (Setting/operation mode status (Xn1): OFF).

(e) When "Auto-setting at Input Range Change" is set to "0: Disable" on Switch Setting (☞ Page 108, Section 7.2)

Set values in the buffer memory (☞ Page 351, Appendix 2 (12) (d)) can be out of the setting range. (When the setting range changes according to the change of the input range, the set value before the change can turn out of the range.) In this case, a write data error (error code: □□□4_H) occurs in the buffer memory area where the value turns out of the setting range. Change the input range after setting each buffer memory area with values within the setting range after the input range change.

(f) Enablement of set contents

Enable the set contents by turning Setting change instruction (YnB) OFF → ON → OFF during the setting mode (Setting/operation mode status (Xn1): OFF).

(g) Precautions

Soon after the input range is changed, input temperature may be unstable. Do not start the control until Temperature conversion completion flag (Un\G786) becomes First temperature conversion completed (1_H).

(13)CH□ Stop mode setting (Un\G33, Un\G65, Un\G97, Un\G129) Standard Heating-cooling

Set the mode activated at PID control stop.

(a) Setting range and action of L60TC4

The following table lists the relationship.

○: Executed ×: Not executed

Mode which can be set	Set value of CH□ Stop mode setting (Un\G33, Un\G65, Un\G97, Un\G129)	Action		
		PID control	Temperature judgment ^{*1}	Alert judgment
Stop	0	×	×	×
Monitor	1	×	○	×
Alert	2	×	○	○

*1 Means that the L60TC4 checks whether the input temperature is in the temperature measurement range set in the input range.

However, action of the L60TC4 differs depending on the following settings.

- CH□ Unused channel setting (Un\G61, Un\G93, Un\G125, Un\G157) (☞ Page 376, Appendix 2 (35))
- Setting/operation mode instruction (Yn1) (☞ Page 330, Appendix 1.2 (1))
- PID continuation flag (Un\G169) (☞ Page 381, Appendix 2 (43))
- CH□ PID control forced stop instruction (YnC to YnF) (☞ Page 333, Appendix 1.2 (7))
- "Output Setting at CPU Stop Error" (Switch Setting) (☞ Page 108, Section 7.2)

For details, refer to the following.

- PID control:☞ Page 150, Section 8.2.7 (7)
- Temperature judgment:☞ Page 336, Appendix 2 (3)
- Alert judgment:☞ Page 166, Section 8.2.11 (5)

(b) Default value

The default values are set to Monitor (1) in all channels.

Point

Default values are set to Monitor (1).

Therefore, channels which temperature sensors are not connected to detect sensor input disconnection and the ALM LED blinks.

When CH□ Unused channel setting (Un\G61, Un\G93, Un\G125, Un\G157) is set to Unused (1), control of the corresponding channel is not performed. For channels which temperature sensors are not connected to, CH□ Unused channel setting (Un\G61, Un\G93, Un\G125, Un\G157) must be set to Unused (1).

(14)CH□ Set value (SV) setting (Un\G34, Un\G66, Un\G98, Un\G130) Standard Heating-cooling

Set the target temperature value of PID control.

(a) Setting range

The setting range is identical to the temperature measurement range of the set input range. (☞ Page 345, Appendix 2 (12))

When a value which is out of the setting range is set, a write data error (error code: □□□4_H) and the following situations occur.

- Error occurrence flag (Xn2) turns on.
- The error code is stored in Error code (Un\G0).

(b) Setting unit

The value to be set differs depending on the stored value in CH□ Decimal point position (Un\G1 to Un\G4).

(☞ Page 334, Appendix 2 (2))

- No decimal place (0): Set a value in 1°C (°F or digit) unit.
- One decimal place (1): Set a value in 0.1°C (°F) unit (tenfold value).

(c) Default value

The default values are set to 0 in all channels.

(15)CH□ Proportional band (P) setting (Un\G35, Un\G67, Un\G99, Un\G131) Standard**CH□ Heating proportional band (Ph) setting (Un\G35, Un\G67, Un\G99,****Un\G131)** Heating-cooling**CH□ Cooling proportional band (Pc) setting (Un\G720, Un\G736, Un\G752,****Un\G768)** Heating-cooling

Set proportional band (P)/heating proportional band (Ph)/cooling proportional band (Pc) to perform PID control.
 (In the heating-cooling control, set heating proportional band (Ph) to Un\G35, Un\G67, Un\G99, Un\G131.)

A**(a) Setting range**

Set the value within the following ranges for the full scale of the set input range. (☞ Page 345, Appendix 2 (12))

- Proportional band (P) setting: 0 to 10000 (0.0% to 1000.0%)
- Heating proportional band (Ph) setting: 0 to 10000 (0.0% to 1000.0%)
- Cooling proportional band (Pc) setting: 1 to 10000 (0.1% to 1000.0%)

Ex. When the value of the buffer memory is set as follows

- CH□ Input range (Un\G32, Un\G64, Un\G96, Un\G128): 38 (temperature measurement range: -200.0 to 400.0°C)
- CH□ Proportional band (P) setting (Un\G35, Un\G67, Un\G99, Un\G131): 100 (10.0%)

$$(\text{Full scale}) \times (\text{Proportional band (P) setting}) = (400.0^\circ\text{C} - (-200.0)) \times 0.1 = 60^\circ\text{C}$$

Set the proportional band (P) to 60°C.

(b) Two-position control

Set the proportional band (P)/heating proportional band (Ph) to 0. (The auto tuning cannot be performed.)

For details on Two-position control, refer to the following.

☞ Page 129, Section 8.2.3

(c) Default value

The default values are set to 30 (3.0%) in all channels.

Point

If the proportional band (P)/heating proportional band (Ph) is set to 0 (0.0%), the auto tuning cannot be performed. To perform the auto tuning, set proportional band (P)/heating proportional band (Ph) to other than 0. For details on the auto tuning function, refer to the following.

Page 141, Section 8.2.7

Remark

The proportional band (P) is the variation width of deviation (E) necessary for manipulated value (MV) to vary 0% to 100%. The following formula shows the relationship between deviation (E) and manipulated value (MV) in proportional action.

$$MV = K_p \cdot E$$

K_p is proportional gain. The following formula shows proportional band (P) in this case.

$$P = \frac{1}{K_p} \cdot 100$$

When the value of the proportional band (P) is increased, the proportional gain (K_p) decreases. Therefore, the manipulated value (MV) for variation of the deviation (E) becomes small.

When the value of proportional band (P) is decreased, the proportional gain (K_p) increases. Therefore, the manipulated value (MV) for variation of the deviation (E) becomes large. The following figure shows the proportional band (P) in reverse action.

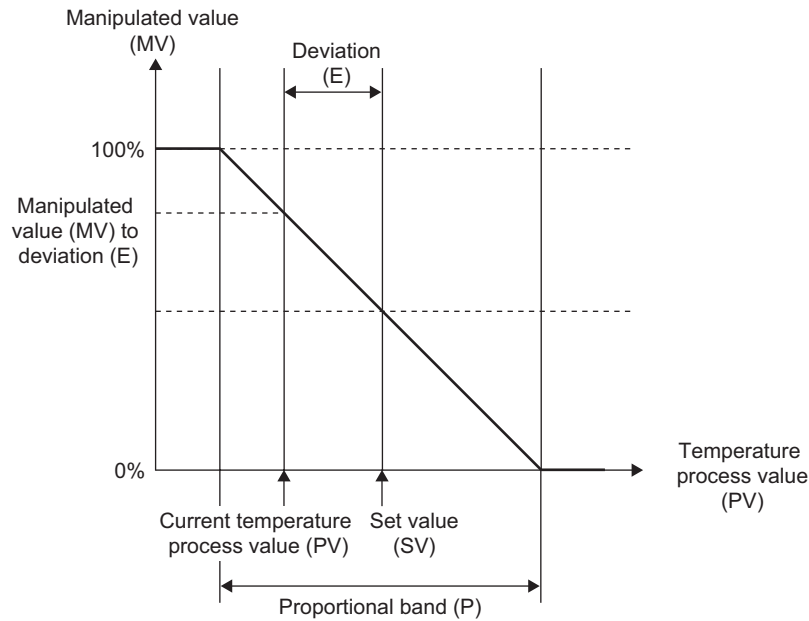

(16)CH□ Integral time (I) setting (Un\G36, Un\G68, Un\G100, Un\G132) Common

Set integral time (I) to perform PID control.

(a) Setting range

The setting range is 0 to 3600 (0 to 3600s).

(b) In the P control or PD control

Set this setting to 0.

For details on control methods, refer to the following.

 Page 129, Section 8.2.3

(c) Default value

The default values are set to 240 (240s) in all channels.

(17)CH□ Derivative time (D) setting (Un\G37, Un\G69, Un\G101, Un\G133) Common

Set derivative time (D) to perform PID control.

(a) Setting range

The setting range is 0 to 3600 (0 to 3600s).

(b) In the P control or PI control

Set this setting to 0.

For details on control methods, refer to the following.

 Page 129, Section 8.2.3

(c) Default value

The default values are set to 60 (60s) in all channels.

(18)CH□ Alert set value 1 (Un\G38, Un\G70, Un\G102, Un\G134) Standard Heating-cooling

CH□ Alert set value 2 (Un\G39, Un\G71, Un\G103, Un\G135) Standard Heating-cooling

CH□ Alert set value 3 (Un\G40, Un\G72, Un\G104, Un\G136) Standard Heating-cooling

CH□ Alert set value 4 (Un\G41, Un\G73, Un\G105, Un\G137) Standard Heating-cooling

Set temperature values where CH□ Alert 1 (Un\G5 to Un\G8 of b8) to CH□ Alert 4 (Un\G5 to Un\G8 of b11) turn on according to selected alert mode of alert 1 to 4.

For CH□ Alert definition (Un\G5 to Un\G8), refer to the following.

☞ Page 336, Appendix 2 (3)

For details on the alert function, refer to the following.

☞ Page 157, Section 8.2.11

(a) Alert mode

Set the alert mode of alert 1 to 4 in the following buffer memory areas. Alert mode of alert 1 to 4 respectively correspond to alert set value 1 to 4.

(b) Setting range

Buffer memory area name	Buffer memory address				Reference
	CH1	CH2	CH3	CH4	
CH□ Alert 1 mode setting	Un\G192	Un\G208	Un\G224	Un\G240	Page 386, Appendix 2 (52)
CH□ Alert 2 mode setting	Un\G193	Un\G209	Un\G225	Un\G241	
CH□ Alert 3 mode setting	Un\G194	Un\G210	Un\G226	Un\G242	
CH□ Alert 4 mode setting	Un\G195	Un\G211	Un\G227	Un\G243	

The setting range differs depending on the setting of the following buffer memory area. (each full scale differs)

- CH□ Input range (Un\G32, Un\G64, Un\G96, Un\G128) (☞ Page 345, Appendix 2 (12))

Also, the setting range differs depending on alert mode to be set. (☞ Page 358, Appendix 2 (18) (a))

Alert mode	Setting range of alert set value	Remarks
No alert	—	—
Upper limit input alert, lower limit input alert	Temperature measurement range of the input range	Same as with standby
Upper limit deviation alert, lower limit deviation alert, upper limit deviation alert (using the set value (SV)), lower limit deviation alert (using the set value (SV))	-(full scale) to +(full scale)	Same as with standby and standby (second time)
Upper lower limit deviation alert, within-range alert, upper lower limit deviation alert (using the set value (SV)), within-range alert (using the set value (SV))	0 to +(full scale)	Same as with standby and standby (second time)

When a value which is out of the setting range is set, a write data error (error code: □□□4_H) and the following situations occur.

- Error occurrence flag (Xn2) turns on.
- The error code is stored in Error code (Un\G0).

(c) Setting unit

The value to be set differs depending on the stored value in CH□ Decimal point position (Un\G1 to Un\G4).

(☞ Page 334, Appendix 2 (2))

- No decimal place (0): Set a value in 1°C (°F or digit) unit.
- One decimal place (1): Set a value in 0.1°C (°F) unit (tenfold value).

(d) Write data error

In the following case, a write data error (error code: □□□4_H) occurs as well as when the setting is out of the setting value. Error occurrence flag (Xn2) turns on and the error code is stored in Error code (Un\G0).

- When the set value is other than 0 when No alert (0) is set in the alert mode

(e) Default value

The default values are set to 0 in all channels.

(19)CH□ Upper limit output limiter (Un\G42, Un\G74, Un\G106, Un\G138) Standard

CH□ Lower limit output limiter (Un\G43, Un\G75, Un\G107, Un\G139) Standard

CH□ Heating upper limit output limiter (Un\G42, Un\G74, Un\G106, Un\G138) Heating-cooling

CH□ Cooling upper limit output limiter (Un\G721, Un\G737, Un\G753, Un\G769)

Heating-cooling

In the standard control, set upper limit value/lower limit value for actual output of manipulated value (MV) calculated by the PID operation to an external device. In the heating-cooling control, set upper limit value of heating/cooling for actual output of manipulated value for heating (MVh)/manipulated value for cooling (MVc) calculated by the PID operation to an external device. Additionally, Un\G42, Un\G74, Un\G106, Un\G138 are used for heating in the heating-cooling control. During the auto tuning, setting of Heating upper limit output limiter and Cooling upper limit output limiter are disabled.

(a) Setting range

The following table lists setting range of each buffer memory.

Buffer memory	Setting range	Remarks
CH□ Upper limit output limiter (Un\G42, Un\G74, Un\G106, Un\G138)	-50 to 1050 (-5.0% to 105.0%)	Set the values to lower limit output limiter value < upper limit output limiter value. When lower limit output limiter value ≥ upper limit output limiter value, write data error (error code: □□□5 _H) occurs. In addition, if the setting is out of the setting value, a write data error (error code: □□□4 _H) occurs. When the error occurs, the following situations occur. • Error occurrence flag (Xn2) turns on. • The error code is stored in Error code (Un\G0).
CH□ Lower limit output limiter (Un\G43, Un\G75, Un\G107, Un\G139)		
CH□ Heating upper limit output limiter (Un\G42, Un\G74, Un\G106, Un\G138)	0 to 1050 (0.0% to 105.0%)	If the setting is out of the setting value, a write data error (error code: □□□4 _H) occurs. When the error occurs, the following situations occur. • Error occurrence flag (Xn2) turns on. • The error code is stored in Error code (Un\G0).
CH□ Cooling upper limit output limiter (Un\G721, Un\G737, Un\G753, Un\G769)		

Point

- In the standard control, CH□ Cooling upper limit output limiter (Un\G721, Un\G737, Un\G753, Un\G769) is invalid even it is set.
- In the heating-cooling control, lower limit value is not used. When CH□ Lower limit output limiter (Un\G43, Un\G75, Un\G107, Un\G139) is set to other than 0, a write data error (error code: □□□2_H) occurs.

(b) Two-position control (☞ Page 129, Section 8.2.3 (1))

The following table lists Enable/Disable of the setting.

Buffer memory	Enable/Disable of the setting in the two-position control
CH☐ Upper limit output limiter (Un\G42, Un\G74, Un\G106, Un\G138)	Disable
CH☐ Lower limit output limiter (Un\G43, Un\G75, Un\G107, Un\G139)	
CH☐ Heating upper limit output limiter (Un\G42, Un\G74, Un\G106, Un\G138)	Enable
CH☐ Cooling upper limit output limiter (Un\G721, Un\G737, Un\G753, Un\G769)	

(c) Manual control (☞ Page 139, Section 8.2.5)

The following table lists Enable/Disable of the setting.

Buffer memory	Enable/Disable of the setting in the manual control	Remarks
CH☐ Upper limit output limiter (Un\G42, Un\G74, Un\G106, Un\G138)	Enable	When an output exceeds the upper limit output limiter value, the manipulated value (MV) of the manual control is fixed (clipped) to the upper limit output limiter value that is set. When an output falls below the lower limit output limiter value, the manipulated value (MV) of the manual control is fixed (clipped) to the lower limit output limiter value that is set.
CH☐ Lower limit output limiter (Un\G43, Un\G75, Un\G107, Un\G139)		
CH☐ Heating upper limit output limiter (Un\G42, Un\G74, Un\G106, Un\G138)	Disable	—
CH☐ Cooling upper limit output limiter (Un\G721, Un\G737, Un\G753, Un\G769)		

(d) Default value

The following table lists the default value of each buffer memory area.

Buffer memory	Default value
CH☐ Upper limit output limiter (Un\G42, Un\G74, Un\G106, Un\G138)	1000 (100.0%)
CH☐ Lower limit output limiter (Un\G43, Un\G75, Un\G107, Un\G139)	0 (0.0%)
CH☐ Heating upper limit output limiter (Un\G42, Un\G74, Un\G106, Un\G138)	1000 (100.0%)
CH☐ Cooling upper limit output limiter (Un\G721, Un\G737, Un\G753, Un\G769)	

(20)CH□ Output variation limiter setting (Un\G44, Un\G76, Un\G108, Un\G140)

Standard Heating-cooling

Set the limit of an output variation per 1s to regulate a rapid change of the manipulated value (MV).

(a) Setting range

The setting range is 0 or 1 to 1000 (0.1%/s to 100.0%/s). When 0 is set, an output variation is not regulated.

Ex. When the value of the buffer memory is set as follows

- CH□ Output variation limiter setting (Un\G44, Un\G76, Un\G108, Un\G140): 10(1.0%/s)
If the manipulated value (MV) rapidly changes by 50%, the variation is regulated to 1%/s. Therefore, it takes 50s until the output actually changes by 50%.

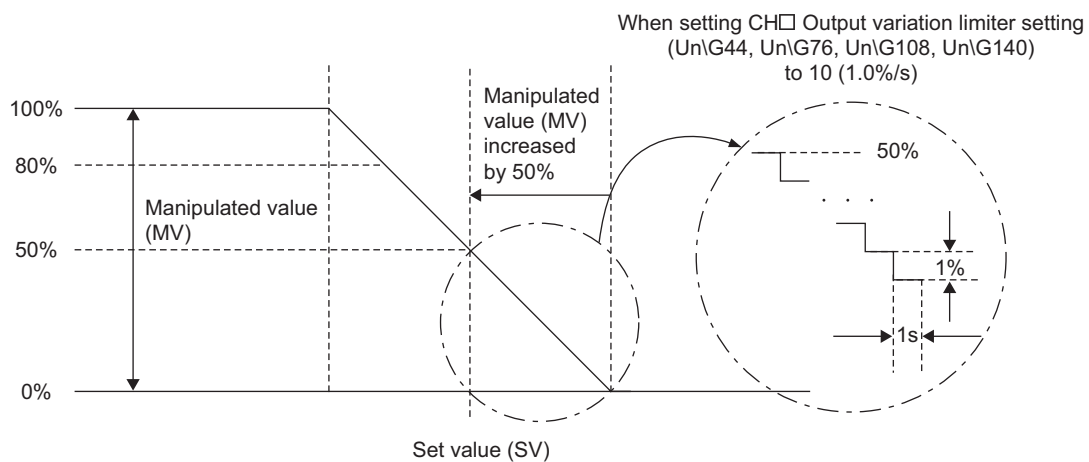

(b) Two-position control (☞ Page 129, Section 8.2.3 (1))

The setting is invalid.

(c) Manual control (☞ Page 139, Section 8.2.5)

The setting is enabled.

(d) Default value

The default values are set to 0 in all channels.

(21)CH□ Sensor correction value setting (Un\G45, Un\G77, Un\G109, Un\G141)**Common**

Set the correction value when measured temperature and actual temperature are different.

For details on the sensor compensation function, refer to the following.

☞ Page 223, Section 8.3.2

(a) Setting range

Set the value within the range -5000 to 5000 (-50.00% to 50.00%) of the full scale of the set input range.

☞ Page 345, Appendix 2 (12))

(b) Enablement of setting contents

When 1-point sensor compensation (standard) (0_H) is set in Sensor compensation function selection

(Un\G785), the setting contents is enabled. ☞ Page 413, Appendix 2 (91))

(c) Default value

The default values are set to 0 (0.00%) in all channels.

(22)CH□ Adjustment sensitivity (dead band) setting (Un\G46, Un\G78, Un\G110, Un\G142)**Standard** Heating-cooling

To prevent a chattering in the two-position control, set the adjustment sensitivity (dead band) for the set value (SV).

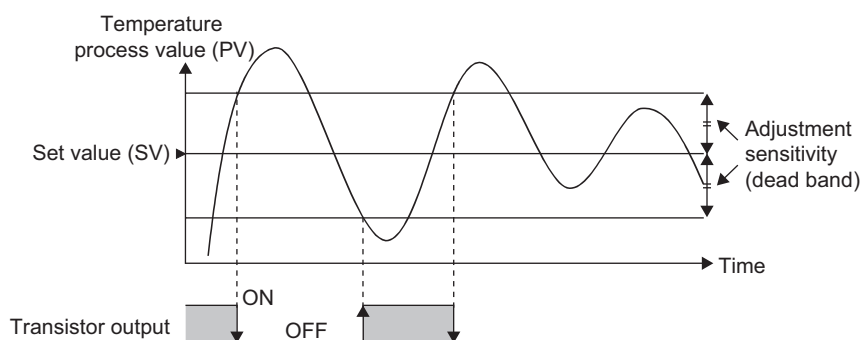

For details on the two-position control, refer to the following.

☞ Page 129, Section 8.2.3

(a) Setting range

Set the value within the range 1 to 100 (0.1% to 10.0%) of the full scale of the set input range. ☞ Page 345, Appendix 2 (12))

Ex. When the value of the buffer memory is set as follows

- CH□ Input range (Un\G32, Un\G64, Un\G96, Un\G128): 38 (temperature measurement range: -200.0 to 400.0°C)
- CH□ Adjustment sensitivity (dead band) setting (Un\G46, Un\G78, Un\G110, Un\G142): 10 (1.0%)
 $(\text{Full scale}) \times (\text{Adjustment sensitivity (dead band) setting}) = (400.0^\circ\text{C} - (-200.0)) \times 0.01 = 6.0^\circ\text{C}$
 The dead band is the set value (SV) $\pm 6.0^\circ\text{C}$.

(b) Default value

The default values are set to 5 (0.5%) in all channels.

(23)CH□ Control output cycle setting (Un\G47, Un\G79, Un\G111, Un\G143) Standard

CH□ Heating control output cycle setting (Un\G47, Un\G79, Un\G111, Un\G143)

Heating-cooling

CH□ Cooling control output cycle setting (Un\G722, Un\G738, Un\G754, Un\G770) Heating-cooling

Set the pulse cycle (ON/OFF cycle) of the transistor output. In the heating-cooling control, the output cycle of the heating control and cooling control can be set individually. Additionally, Un\G47, Un\G79, Un\G111, Un\G143 are used for heating in the heating-cooling control.

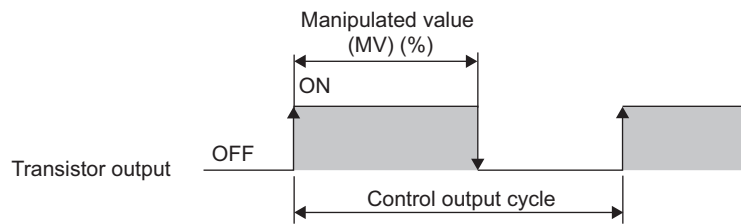

The ON time of the control output cycle is determined by multiplying the control output cycle by the manipulated value (MV)^{*1} (%) calculated by PID operation. If the manipulated value (MV)^{*1} is constant, a pulse of the same cycle is output repeatedly.

*1 For the heating control output cycle, the manipulated value for heating (MVh) is used. For the cooling control output cycle, manipulated value for cooling (MVC) is used.

Ex. When 700 (70%) is stored in CH□ Manipulated value (MV) (Un\G13 to Un\G16) and the value of the buffer memory is set as follows

- CH□ Control output cycle setting (Un\G47, Un\G79, Un\G111, Un\G143): 100 (100s)
 $100s \times 0.7 (70\%) = 70s$
The ON time is 70s.
The transistor output turns on for 70s and off for 30s per 100s.

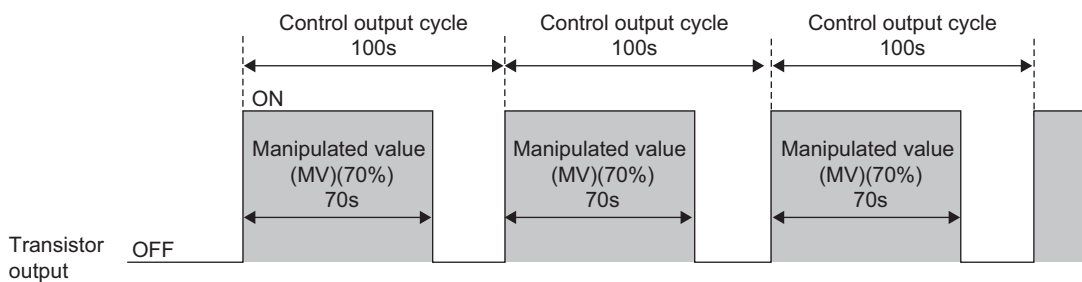

(a) Setting range

- When the control output cycle unit selection setting on Switch Setting is set to the cycle of 1s: 1 to 100 (1s to 100s)
- When the control output cycle unit selection setting on Switch Setting is set to the cycle of 0.1s: 5 to 1000 (0.5s to 100.0s)

For details on the control output cycle unit selection setting function, refer to the following.

Page 140, Section 8.2.6

(b) Default value

- When the control output cycle unit selection setting on Switch Setting is set to the cycle of 1s: 30 (30s)
- When the control output cycle unit selection setting on Switch Setting is set to the cycle of 0.1s: 300 (30.0s)

(24)CH□ Primary delay digital filter setting (Un\G48, Un\G80, Un\G112, Un\G144)

Common

The temperature process values (PV) are smoothed and sudden changes are absorbed by using the primary delay digital filter.

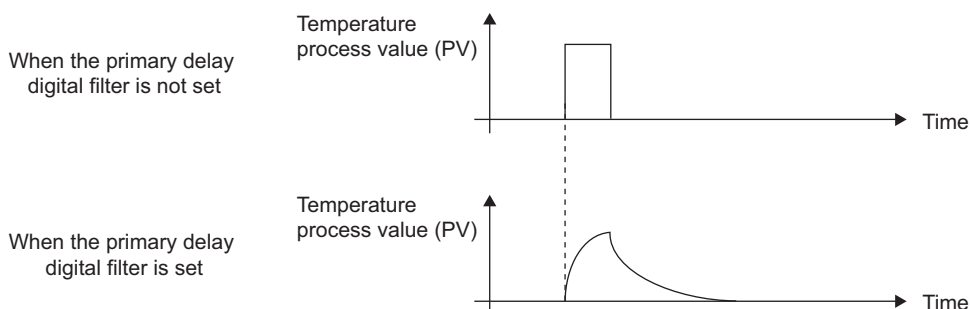

The time for the temperature process value (PV) to change by 63.3% can be set by the primary delay digital filter setting (filter setting time).

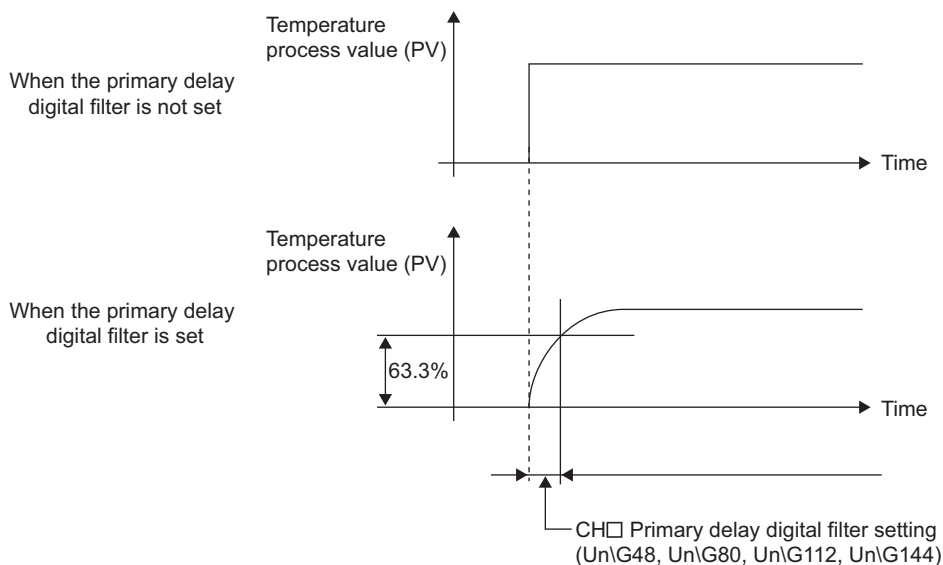

(a) Setting range

The setting range is 0 or 1 to 100 (1s to 100s). When 0 is set, the primary delay digital filter processing is not performed.

(b) Default value

The default values are set to 0 in all channels.

A

Appendix 2 Details of the Buffer Memory

(25)CH□ Control response parameter (Un\G49, Un\G81, Un\G113, Un\G145)

Standard Heating-cooling

In the simple two-degree-of-freedom PID control, select the response speed to the change of the set value (SV) from the following three levels: Slow, Normal, and Fast.

For details on the simple two-degree-of-freedom, refer to the following.

☞ Page 153, Section 8.2.8

(a) Setting range

Set value	Setting contents	Description
0	Slow	Set Slow when reducing an overshoot and undershoot to the change of the set value (SV). However, the settling time is the longest of the three settings.
1	Normal	Normal has features between Slow and Fast.
2	Fast	Set Fast when speeding up the response to the change of the set value (SV). However, an overshoot and undershoot is the largest of the three settings.

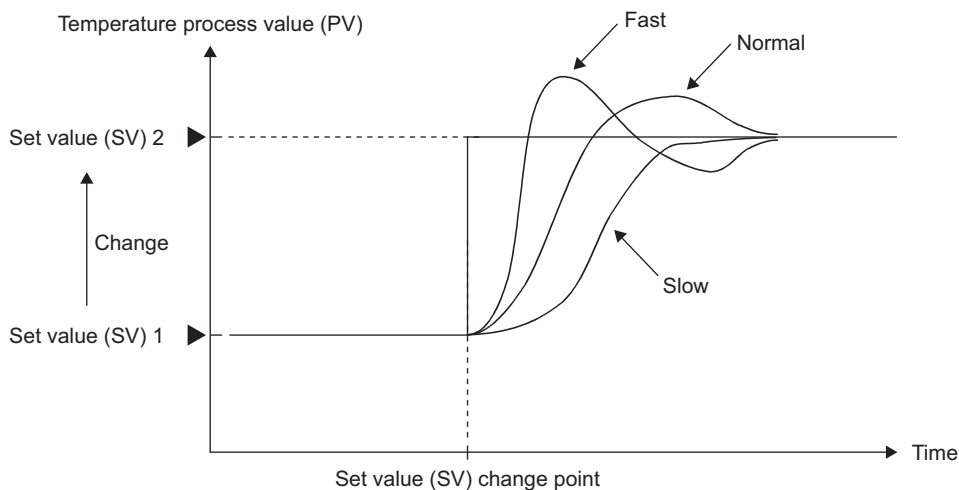

(b) Default value

The default values are set to Slow (0) in all channels.

(26)CH□ AUTO/MAN mode shift (Un\G50, Un\G82, Un\G114, Un\G146) Standard Heating-cooling

Select whether to calculate the manipulated value (MV) by PID operation or to set it manually by the user.

(a) Setting range

Set value	Setting contents	Description
0	AUTO	Activates the AUTO mode. The manipulated value (MV) calculated by PID operation is used to calculate the ON time of the control cycle.
1	MAN	Activates the MAN mode. The manipulated value (MV) written in CH□ MAN output setting (Un\G51, Un\G83, Un\G115, Un\G147) is used to calculate the ON time of the control output cycle.

(b) When AUTO mode is shifted to MAN mode

The following operation is performed.

- The manipulated value (MV) calculated by PID operation is transferred to CH□ MAN output setting (Un\G51, Un\G83, Un\G115, Un\G147). (For preventing a rapid change of the manipulated value (MV))
- When the shift to the MAN mode is completed, bits of the corresponding channel of MAN mode shift completion flag (Un\G30) are set to MAN mode shift completed (1).

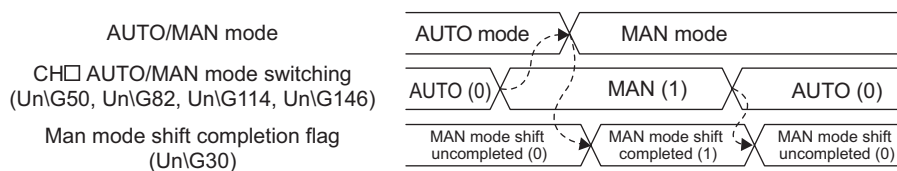

-----> Executed by the L60TC4

Point

Set the manipulated value (MV) in MAN mode after confirming completion of the mode shift.

(c) When performing auto tuning

Set to AUTO (0). If MAN (1) is set, the auto tuning is not performed.

(d) Default value

The default values are set to AUTO (0) in all channels.

(27) CH□ MAN output setting (Un\G51, Un\G83, Un\G115, Un\G147) Standard Heating-cooling

This buffer memory area is used for setting the manipulated value (MV) in the MAN mode.

(a) How to shift the mode

Shift the mode by the following buffer memory area.

- CH□ AUTO/MAN mode shift (Un\G50, Un\G82, Un\G114, Un\G146) (☞ Page 367, Appendix 2 (26))

(b) Setting range

The setting range is different between the standard control and the heating-cooling control. (☞ Page 126, Section 8.2.1)

- In standard control: -50 to 1050 (-5.0 to 105.0%)
- In heating-cooling control: -1050 to 1050 (-105.0 to 105.0%)

(c) Enablement of setting contents

Make sure the corresponding bits of MAN mode shift completion flag (Un\G30) has been set to 1 (ON) and write a value in the MAN output setting.

A value that is written when MAN mode shift completion flag is OFF will be replaced with the manipulated value (MV) calculated by PID operation by the system.

(d) Default value

The default values are set to 0 (0.0%) in all channels.

(28)CH□ Setting change rate limiter (Un\G52, Un\G84, Un\G116, Un\G148)

Standard Heating-cooling

CH□ Setting change rate limiter (temperature rise) (Un\G52, Un\G84, Un\G116,

Un\G148) Standard Heating-cooling

CH□ Setting change rate limiter (temperature drop) (Un\G564, Un\G596,

Un\G628, Un\G660) Standard Heating-cooling

Set the change rate of the set value (SV) per a set time unit when the set value (SV) is changed. This setting can regulate a rapid change of the manipulated value (MV). Set a time unit in CH□ Setting change rate limiter time unit setting (Un\G735, Un\G751, Un\G767, Un\G783). (☞ Page 411, Appendix 2 (89))

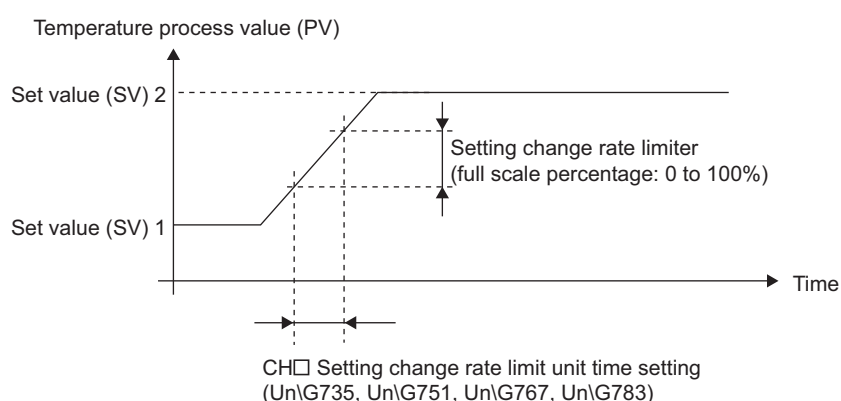
**(a) Batch/individual setting of temperature rise and temperature drop**

Setting change rate limiter for the temperature rise and the temperature drop can be set in a batch or individually. Select it on Switch Setting.

For details on the setting method, refer to the following.

☞ Page 108, Section 7.2

When setting change rate limiter is set individually, Un\G52, Un\G84, Un\G116, Un\G148 is for the temperature rise. The following table lists the buffer memory areas to be referred to.

Batch/Individual	Buffer memory area name	Buffer memory address			
		CH1	CH2	CH3	CH4
Batch	CH□ Setting change rate limiter	Un\G52	Un\G84	Un\G116	Un\G148
Individual	CH□ Setting change rate limiter (temperature rise)	Un\G52	Un\G84	Un\G116	Un\G148
	CH□ Setting change rate limiter (temperature drop)	Un\G564	Un\G596	Un\G628	Un\G660

For details on the function, refer to the following.

☞ Page 155, Section 8.2.10

(b) Setting range

Set 0 or the value within the range of 1 to 1000 (0.1% to 100.0%) toward the full scale of the set input range.

When 0 is set, the setting is disabled.

(c) Default value

The default values are set to 0 in all channels.

(29)CH□ AT bias setting (Un\G53, Un\G85, Un\G117, Un\G149) Standard Heating-cooling

The point set as the set value (SV) in the auto tuning can be rearranged by using this buffer memory area.

The auto tuning function determines each PID constant by performing the two-position control toward the set value (SV) and making a temperature process value (PV) hunting.

Set CH□ AT bias setting (Un\G53, Un\G85, Un\G117, Un\G149) when an overshoot caused by the hunting is improper.

The auto tuning is performed with having the AT point (the point rearranged by the setting) as its center. When the auto tuning is completed, the L60TC4 performs a control toward the set value (SV) to which the value set in the AT bias is added, not the set value (SV) itself.

For details on the auto tuning function, refer to the following.

☞ Page 141, Section 8.2.7

Ex. When AT bias is set to minus value (reverse action)

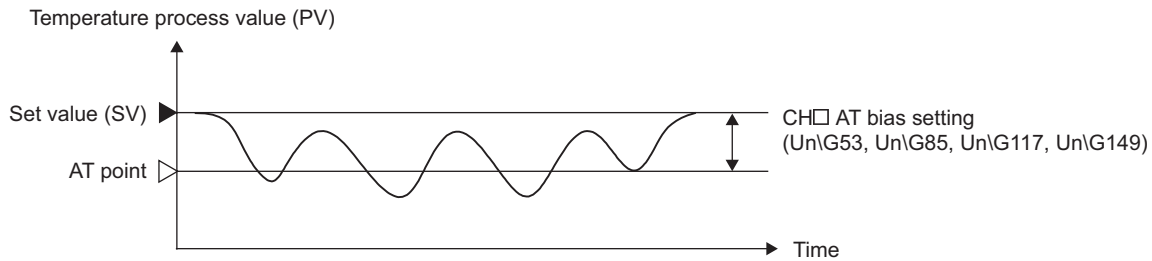

(a) Setting range

The setting range is from -(full scale) to +(full scale). The setting range depends on the input range setting.

☞ Page 345, Appendix 2 (12))

Ex. When the value of the buffer memory is set as follows

- CH□ Input range (Un\G32, Un\G64, Un\G96, Un\G128): 38 (temperature measurement range -200.0 to 400.0°C, resolution: 0.1)

The setting range is -6000 to 6000.

(b) Setting unit

The value to be set differs depending on the stored value in CH□ Decimal point position (Un\G1 to Un\G4).

☞ Page 334, Appendix 2 (2))

- No decimal place (0): Set a value in 1°C (°F or digit) unit.
- One decimal place (1): Set a value in 0.1°C (°F) unit (tenfold value).

(c) Default value

The default values are set to 0 in all channels.

(d) Precautions

For CH□ AT bias setting (Un\G53, Un\G85, Un\G117, Un\G149), set the range where PID operation fluctuates slightly and the control result get no effect.

Depending on the controlled object, accurate PID constants may not be obtained.

(30)CH□ Forward/reverse action setting (Un\G54, Un\G86, Un\G118, Un\G150)**Standard**

Select whether to use channels in the forward action or reverse action.

Select the forward action for the cooling control. Select the reverse action for the heating control.

For details on the forward action/reverse action selection function, refer to the following.

 Page 203, Section 8.2.18

(a) Setting range

- 0: Forward action
- 1: Reverse action

(b) Default value

The default values are set to Reverse action (1) in all channels.

A

(31)CH□ Upper limit setting limiter (Un\G55, Un\G87, Un\G119, Un\G151)

Standard Heating-cooling

CH□ Lower limit setting limiter (Un\G56, Un\G88, Un\G120, Un\G152)

Standard Heating-cooling

Upper/lower limit value of the set value (SV) can be set.

(a) Setting range

The setting range is identical to the temperature measurement range of the set input range. (☞ Page 345, Appendix 2 (12))

The setting should meet the following conditions.

- CH□ Lower limit setting limiter (Un\G56, Un\G88, Un\G120, Un\G152)
 < CH□ Upper limit setting limiter (Un\G55, Un\G87, Un\G119, Un\G151)

If the above conditions are not met, a write data error (error code: □□□5_H) occurs.

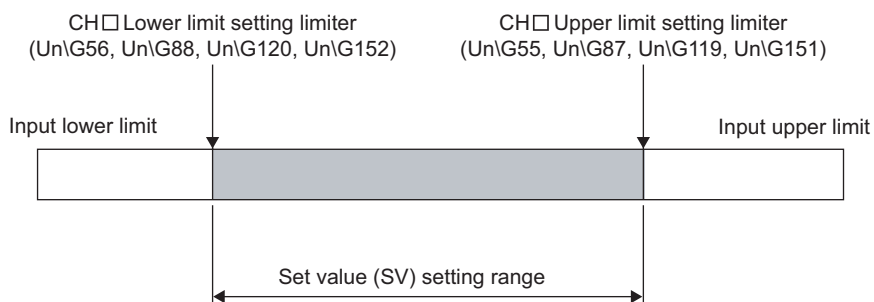

(b) Setting unit

The value to be set differs depending on the stored value in CH□ Decimal point position (Un\G1 to Un\G4).

(☞ Page 334, Appendix 2 (2))

- No decimal place (0): Set a value in 1°C (°F or digit) unit.
- One decimal place (1): Set a value in 0.1°C (°F) unit (tenfold value).

(c) Default value

A default value differs depending on modules to be used.

Buffer memory	Default value	
	L60TCTT4/L60TCTT4BW	L60TCRT4/L60TCRT4BW
CH□ Upper limit setting limiter (Un\G55, Un\G87, Un\G119, Un\G151)	1300	6000
CH□ Lower limit setting limiter (Un\G56, Un\G88, Un\G120, Un\G152)	0	-2000

(32)CH□ Heater disconnection alert setting (Un\G58, Un\G90, Un\G122, Un\G154)**Standard** Heating-cooling

Set the set value in heater disconnection detection and off-time current error detection in percentage of the reference heater current value.

For details on the heater disconnection detection function, refer to the following.

☞ Page 215, Section 8.2.24

For details on the output off-time current error detection function, refer to the following.

☞ Page 220, Section 8.2.25

(a) Supported modules

- L60TCTT4BW
- L60TCRT4BW

(b) Setting range

The setting range is 0 to 100 (%).

Ex. To generate Heater disconnection alert with the following conditions

- CT□ Reference heater current value (Un\G280 to Un\G287): 100 (10.0A)
- When CT□ Heater current process value (Un\G256 to Un\G263) is 80 (8.0A) or less, set CH□ Heater disconnection alert setting (Un\G58, Un\G90, Un\G122, Un\G154) to 80 (%).

$$\text{Heater disconnection alert setting} = 100 - \frac{\text{Reference heater current value} - \text{Heater current measurement value}}{\text{Reference heater current value}} \times 100 = 100 - \frac{100 - 80}{100} \times 100 = 80(\%)$$

When 0 is set, heater disconnection detection and off-time current error detection are not performed.

(c) Default value

The default values are set to 0 (%) in all channels.

A

(33)CH□ Loop disconnection detection judgment time (Un\G59, Un\G91, Un\G123, Un\G155) Standard

Errors such as disconnection of resistors, malfunction of an external controller, and errors of the control system due to troubles such as disconnection of the sensor can be detected by the loop disconnection detection function.

If temperature does not change by 2°C (°F) or more in the Loop disconnection detection judgment time, a loop disconnection is detected.

For details on the loop disconnection detection function, refer to the following.

 Page 204, Section 8.2.19

(a) Setting range

The setting range is 0 to 7200 (s).

Set a value that exceeds the time in which temperature changes by 2°C (°F).

(b) When performing auto tuning

For this setting, the twice value of that of CH□ Integral time (I) setting (Un\G36, Un\G68, Un\G100, Un\G132) is automatically set. ( Page 357, Appendix 2 (16)) However, when this setting is set to 0 (s) at the start of the auto tuning, Loop disconnection detection judgment time is not stored.

(c) Default value

The default values are set to 480 (s) in all channels.

(34)CH□ Loop disconnection detection dead band (Un\G60, Un\G92, Un\G124,**Un\G156)** **Standard**

To prevent an error alarm of Loop disconnection detection, set a non-alert band (temperature band in which the loop disconnection is not detected) where the set value (SV) is at the center.

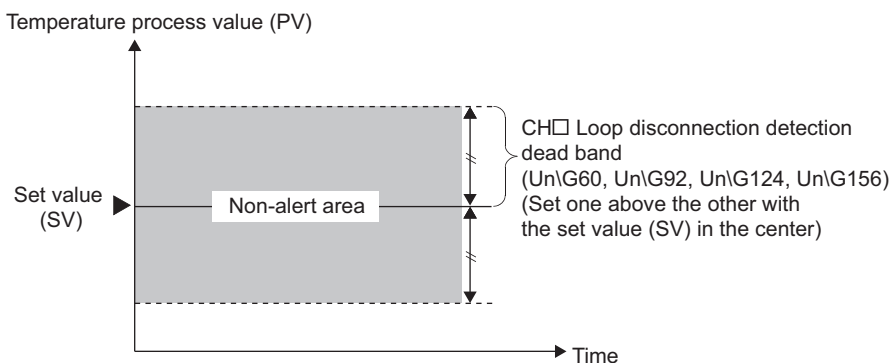

For details on the loop disconnection detection function, refer to the following.

Page 204, Section 8.2.19

(a) Setting range

The setting range is identical to the temperature measurement range of the set input range. Page 345, Appendix 2 (12))

Ex. When the value of the buffer memory is set as follows

- CH□ Input range (Un\G32, Un\G64, Un\G96, Un\G128): 38 (resolution: 0.1)
- CH□ Loop disconnection detection dead band (Un\G60, Un\G92, Un\G124, Un\G156): 50
(Loop disconnection detection dead band set value) × (resolution) = 50 × 0.1 = 5.0°C

Within the range of the set value (SV) ±5.0°C, Loop disconnection is not detected.

(b) Setting unit

The value to be set differs depending on the stored value in CH□ Decimal point position (Un\G1 to Un\G4).

Page 334, Appendix 2 (2))

- No decimal place (0): Set a value in 1°C (°F or digit) unit.
- One decimal place (1): Set a value in 0.1°C (°F) unit (tenfold value).

(c) Default value

The default values are set to 0 in all channels.

(35)CH□ Unused channel setting (Un\G61, Un\G93, Un\G125, Un\G157) Standard Heating-cooling

Set this buffer memory area when treating channels that do not control temperature or are not connected with temperature sensors as "Unused". Setting them as unused channels stops detection of an alert.

For details on the unused channel setting, refer to the following.

 Page 106, Section 6.6

(a) Setting range

- 0: Use
- 1: Unused

(b) Default value

The default values are set to Use (0) in all channels.

(c) ON of Default setting registration instruction (Yn9) (Page 332, Appendix 1.2 (5))

When Default setting registration instruction (Yn9) is turn on from off, CH□ Unused channel setting (Un\G61, Un\G93, Un\G125, Un\G157) is reset to Use (0).

Channels that do not control temperature or are not connected to temperature sensors needs to be set as unused channels again after settings of other buffer memory areas and non-volatile memories return to the default values. Set CH□ Unused channel setting (Un\G61, Un\G93, Un\G125, Un\G157) to Unused (1) again.

(36)CH□ Memory of PID constants read instruction (Un\G62, Un\G94, Un\G126, Un\G158) Standard Heating-cooling

PID constants are read from a non-volatile memory and stored in the buffer memory by using this instruction. Setting this buffer memory area to Requested (1) stores the value backed up in the non-volatile memory in the buffer memory.

(a) buffer memory areas to store set value of non-volatile memory

The following table lists the buffer memory areas whose set value is read.

Buffer memory area name	Buffer memory address				Reference
	CH1	CH2	CH3	CH4	
CH□ Proportional band (P) setting	Un\G35	Un\G67	Un\G99	Un\G131	Page 355, Appendix 2 (15)
CH□ Heating proportional band (Ph) setting	Un\G35	Un\G67	Un\G99	Un\G131	
CH□ Cooling proportional band (Pc) setting	Un\G720	Un\G736	Un\G752	Un\G768	
CH□ Integral time (I) setting	Un\G36	Un\G68	Un\G100	Un\G132	Page 357, Appendix 2 (16)
CH□ Derivative time (D) setting	Un\G37	Un\G69	Un\G101	Un\G133	Page 357, Appendix 2 (17)
CH□ Loop disconnection detection judgment time	Un\G59	Un\G91	Un\G123	Un\G155	Page 374, Appendix 2 (33)

(b) Setting range

- 0: Not requested
- 1: Requested

(c) Default value

The default values are set to Not requested (0) in all channels.

(d) Precautions

When Requested (1) is set, do not perform the following operations. An incorrect value may be stored in the non-volatile memory.

- Change of the set value of the buffer memory read from the non-volatile memory by this instruction (☞ Page 378, Appendix 2 (37) (a))
- Memory back up (☞ Page 235, Section 8.3.4)
- Default setting registration (☞ Page 332, Appendix 1.2 (5))
- Auto tuning (☞ Page 141, Section 8.2.7)

Point

- When the initial setting by a programming tool is already configured, PID constants should be backed up to a non-volatile memory after the auto tuning. Turning on this instruction at the next start-up can omit the auto tuning.
- This instruction is enabled in the setting mode or operation mode. (☞ Page 324, Appendix 1.1 (2)) However, it is disabled when CH□ Auto tuning instruction (Yn4 to Yn7) is ON. (☞ Page 141, Section 8.2.7)

(37)CH□ Automatic backup setting after auto tuning of PID constants (Un\G63, Un\G95, Un\G127, Un\G159) Standard Heating-cooling

The set value to be stored in the buffer memory is automatically backed up to a non-volatile memory by using this function. By reading the set value that is backed up, when the power is turned on from off or the CPU module is released from the reset status, another auto tuning can be omitted.

For details on the auto tuning function, refer to the following.

 Page 141, Section 8.2.7

(a) buffer memory areas whose set value is backed up to a non-volatile memory

The following table lists the buffer memory areas whose setting is backed up.

Buffer memory area name	Buffer memory address				Reference
	CH1	CH2	CH3	CH4	
CH□ Proportional band (P) setting	Un\G35	Un\G67	Un\G99	Un\G131	Page 355, Appendix 2 (15)
CH□ Heating proportional band (Ph) setting	Un\G35	Un\G67	Un\G99	Un\G131	
CH□ Cooling proportional band (Pc) setting	Un\G720	Un\G736	Un\G752	Un\G768	
CH□ Integral time (I) setting	Un\G36	Un\G68	Un\G100	Un\G132	Page 357, Appendix 2 (16)
CH□ Derivative time (D) setting	Un\G37	Un\G69	Un\G101	Un\G133	Page 357, Appendix 2 (17)
CH□ Loop disconnection detection judgment time	Un\G59	Un\G91	Un\G123	Un\G155	Page 374, Appendix 2 (33)

(b) Setting range



- 0: Disable
- 1: Enable

(c) Default value

The default values are set to Disable (0) in all channels.

(d) Precautions

When Enable (1) is set, do not perform the following operations. An incorrect value may be stored in the non-volatile memory.

- Changing the set value of the buffer memory
- Memory back up ( Page 235, Section 8.3.4)
- Default setting registration ( Page 332, Appendix 1.2 (5))
- Change to Disable (0) during the auto tuning

(38) Alert dead band setting (Un\G164) Standard Heating-cooling

This setting is for using the alarm function.

For details on the alert function, refer to the following.

 Page 157, Section 8.2.11

(a) Setting range

Set the value within the range 0 to 100 (0.0% to 10.0%) of the full scale of the set input range. ( Page 345, Appendix 2 (12))

Ex. When the value of the buffer memory is set as follows

- CH□ Input range (Un\G32, Un\G64, Un\G96, Un\G128): 2 (temperature measurement range 0 to 1300°C)
- Alert dead band setting (Un\G164): 5 (0.5%)
 $(\text{Full scale}) \times (\text{Alert dead band}) = (1300^\circ\text{C} - 0^\circ\text{C}) \times 0.005 = 6.5^\circ\text{C}$
 The dead band is the alert set value (SV) $\pm 6.5^\circ\text{C}$.

(b) Default value

The default value is set to 5 (0.5%).

(39) Number of alert delay (Un\G165) Standard Heating-cooling

Set the number of sampling for an alert judgment.

By setting number of sampling, when the temperature process value (PV) stays within the alert area until the number of sampling exceeds the number of alert delay, the alert status will be active.

For details on the alert function, refer to the following.

 Page 157, Section 8.2.11

(a) Setting range

The setting range is 0 to 255 (times).

(b) Default value

The default value is set to 0 (times).

(40) Heater disconnection/output off-time current error detection delay count

(Un\G166) **Standard** **Heating-cooling**

Set the limit value for consecutive heater disconnection detections and output off-time current error detections so that the errors exceeding the limit value triggers an alert judgment.

For details on the heater disconnection detection function, refer to the following.

☞ Page 215, Section 8.2.24

For details on the output off-time current error detection function, refer to the following.

☞ Page 220, Section 8.2.25

(a) Supported modules

- L60TCTT4BW
- L60TCRT4BW

(b) Setting range

The setting range is 3 to 255 (times).

(c) Default value

The default value is set to 3 (times).

(41) Temperature rise completion range setting (Un\G167) **Standard** **Heating-cooling**

Set the vertical range of the temperature rise completion range.

When the temperature process value (PV) meets the following conditions, the temperature rise is completed.

- Set value (SV) - Temperature rise completion range \leq Temperature process value (PV) \leq Set value (SV) + Temperature rise completion range

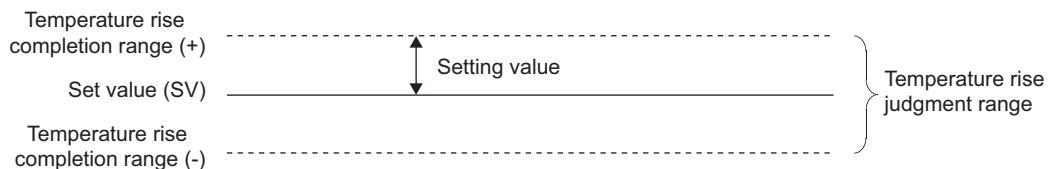

When CH□ Temperature process value (PV) (Un\G9 to Un\G12) enters the temperature rise judgment range, CH□ Temperature rise judgment flag (Un\G17 to Un\G20) is set to Within temperature rise completion range (1). (Set the time from the temperature rise completion to Within temperature rise completion range (1) in Temperature rise completion soak time setting (Un\G168).)

(a) Setting range

- When the temperature unit of the input range is °C: 1 to 10 (°C)
- When the temperature unit of the Input range is °F: 1 to 10 (°F)
- Other than above: 1 to 10 (%) of the full scale

(b) Default value

The default value is set to 1.

(42) Temperature rise completion soak time setting (Un\G168) **Standard** **Heating-cooling**

Set the delay time for CH□ Temperature rise judgment flag (Un\G17 to Un\G20) (☞ Page 340, Appendix 2 (6)) to be set to Within temperature rise completion range (1).

(a) Setting range

The setting range is 0 to 3600 (min).

(b) Default value

The default value is set to 0 (min).

(43) PID continuation flag (Un\G169) **Standard** **Heating-cooling**

Set the operation status at the time when the mode has shifted from the operation mode to the setting mode (Setting/operation mode instruction (Yn1) ON → OFF).

For details on the relationship between this flag and the control status, refer to the following.

- PID control: ☞ Page 134, Section 8.2.3 (6)
- Temperature judgment: ☞ Page 336, Appendix 2 (3)
- Alert judgment: ☞ Page 166, Section 8.2.11 (5)

(a) Setting range

- 0: Stop
- 1: Continue

(b) Default value

The default value is set to Stop (0).

(44) Heater disconnection correction function selection (Un\G170) **Standard** **Heating-cooling**

Set whether to use the heater disconnection correction function or not.

For details on the heater disconnection correction function, refer to the following.

☞ Page 217, Section 8.2.24 (3)

(a) Supported modules

- L60TCTT4BW
- L60TCRT4BW

(b) Setting range

- 0: Not use the heater disconnection correction function
- 1: Use the heater disconnection correction function

(c) Default value

The default value is set to Not use the heater disconnection correction function (0).

(45) Transistor output monitor ON delay time setting (Un\G175) Standard Heating-cooling

Set the delay time of the ON delay output flag.

Set this buffer memory area to perform the heater disconnection detection with an input module.

For ON delay output flag, refer to the following.

 Page 341, Appendix 2 (7)

For details on the ON delay output function, refer to the following.

 Page 174, Section 8.2.14

(a) Setting range

The setting range is 0 or 1 to 50 (10 to 500ms).

When 0 is set, ON delay output flag is not set to 1 (ON).

(b) Default value

The default value is set to 0.

(46) CT monitor method switching (Un\G176) Standard Heating-cooling

Set the method for performing the heater current measurement.

(a) Supported modules

- L60TCTT4BW
- L60TCRT4BW

(b) Setting range

- 0: ON current/OFF current
- 1: ON current

When ON current/OFF current (0) is set, the present current value of the current sensor (CT) is measured.

Selecting ON current (1) fixes the current value of the heater being OFF as the current value of the heater previously being ON.

(c) Default value

The default value is set to ON current/OFF current (0).

(47)CH□ Manipulated value (MV) for output with another analog module (Un\G177 to Un\G180) Standard

CH□ Manipulated value of heating (MVh) for output with another analog module (Un\G177 to Un\G180) Heating-cooling

CH□ Manipulated value of cooling (MVc) for output with another analog module (Un\G708 to Un\G711) Heating-cooling

The values stored in the following buffer memory areas are converted for other analog modules such as a D/A converter module and stored in these buffer memory areas.

Buffer memory area name	Buffer memory address				Reference
	CH1	CH2	CH3	CH4	
CH□ Manipulated value (MV)	Un\G13	Un\G14	Un\G15	Un\G16	Page 339, Appendix 2 (5)
CH□ Manipulated value for heating (MVh)	Un\G13	Un\G14	Un\G15	Un\G16	
CH□ Manipulated value for cooling (MVc)	Un\G704	Un\G705	Un\G706	Un\G707	

Un\G177 to Un\G180 are used for heating in the heating-cooling control.

The store range differs depending on the resolution set in the following buffer memory area. (0 to 4000/0 to 12000/0 to 16000/0 to 20000)

- Resolution of the manipulated value for output with another analog module (Un\G181) (☞ Page 384, Appendix 2 (48))

For details, refer to the following.

☞ Page 173, Section 8.2.13 (2)

Point

When the device which performs heating or cooling can receive only the analog input, use other analog modules (such as D/A converter module) to convert the digital output to the analog input.

(48) Resolution of the manipulated value for output with another analog module

(Un\G181) **Standard** **Heating-cooling**

Set the resolution of the following buffer memory areas. (☞ Page 339, Appendix 2 (5))

- CH□ Manipulated value (MV) (Un\G13 to Un\G16)
- CH□ Manipulated value for heating (MVh) (Un\G13 to Un\G16)
- CH□ Manipulated value for cooling (MVc) (Un\G704 to Un\G707)

For details, refer to the following.

☞ Page 173, Section 8.2.13 (2)

(a) Setting range

- 0: 0 to 4000
- 1: 0 to 12000
- 2: 0 to 16000
- 3: 0 to 20000

The manipulated value (MV) reflecting the resolution is stored in the following buffer memory areas.

☞ Page 383, Appendix 2 (47))

- CH□ Manipulated value (MV) for output with another analog module (Un\G177 to Un\G180)
- CH□ Manipulated value of heating (MVh) for output with another analog module (Un\G177 to Un\G180)
- CH□ Manipulated value of cooling (MVc) for output with another analog module (Un\G708 to Un\G711)

(b) Enablement of setting contents

Enable the setting contents by turning Setting change instruction (YnB) OFF → ON → OFF during the setting mode (Setting/operation mode status (Xn1): OFF).

(c) Default value

The default value is set to 0 to 4000 (0).

(49) Cold junction temperature compensation selection (Un\G182) **Common**

Select whether to perform the cold junction temperature compensation using a standard terminal block or not to perform the cold junction temperature compensation.

(a) Supported modules

- L60TCTT4
- L60TCTT4BW

(b) Setting range

- 0: Use Standard Terminal Block
- 1: This setting cannot be used.
- 2: Not use cold junction temperature compensation

(c) Default value

The default value is set to Use Standard Terminal Block (0).

(50)Control switching monitor (Un\G183) Common

The setting contents of the mode selection set on Switch Setting are stored in this buffer memory area. The mode in operation can be confirmed.

The following table lists the stored value and the contents.

Stored value	Mode	
	Control mode	
0 _H	Temperature control mode	Standard control
1 _H		Heating-cooling control (normal mode)
2 _H		Heating-cooling control (expanded mode)
3 _H		Mix control (normal mode)
4 _H		Mix control (expanded mode)
100 _H	Temperature input mode	

Select the mode on Switch Setting.

For details on the setting method, refer to the following.

 Page 108, Section 7.2

For details on the modes, refer to the following.

 Page 116, Section 8.1, Page 126, Section 8.2.1

(51)CH□ Auto tuning mode selection (Un\G184 to Un\G187) Standard Heating-cooling

Select the auto tuning mode from the following two modes according to the controlled object to be used.

Auto tuning mode	Description
Standard mode	<p>The standard mode is appropriate for most controlled objects. This mode is especially suitable for controlled objects that have an extremely slow response speed or can be affected by noise or disturbance.</p> <p>However, PID constants of slow response (low gain) may be calculated from controlled objects whose ON time or OFF time in the auto tuning is only around 10s.</p> <p>In this case, PID constants of fast response can be calculated by selecting the high response mode and performing the auto tuning.</p>
High response mode	<p>This mode is suitable for controlled objects whose ON time or OFF time in the auto tuning is only around 10s. PID constants of fast response (high gain) can be calculated.</p> <p>However, the temperature process value (PV) may oscillates near the set value (SV) because of the too high gain of the PID constants calculated. In this case, select the normal mode and perform the auto tuning.</p>

For details on the auto tuning function, refer to the following.

 Page 141, Section 8.2.7

(a) Setting range

- 0: Standard mode
- 1: High response mode

(b) Default value

The default values are set to Standard mode (0) in all channels.

(52)CH□ Alert 1 mode setting (Un\G192, Un\G208, Un\G224, Un\G240) Standard Heating-cooling

CH□ Alert 2 mode setting (Un\G193, Un\G209, Un\G225 Un\G241) Standard Heating-cooling

CH□ Alert 3 mode setting (Un\G194, Un\G210, Un\G226, Un\G242) Standard Heating-cooling

CH□ Alert 4 mode setting (Un\G195, Un\G211, Un\G227, Un\G243) Standard Heating-cooling

Set the alert mode of alert 1 to 4.

For details on the alert function, refer to the following.

 Page 157, Section 8.2.11



(a) Alert mode and alert set value

Any alert set value can be set in each alert mode of alert 1 to 4 selected in this setting. Set the alert set value 1 to 4 in the following buffer memory areas. Alert set values 1 to 4 respectively correspond to alert modes of alert 1 to 4.

Buffer memory area name	Buffer memory address				Reference
	CH1	CH2	CH3	CH4	
CH□ Alert set value 1	Un\G38	Un\G70	Un\G102	Un\G134	Page 358, Appendix 2 (18)
CH□ Alert set value 2	Un\G39	Un\G71	Un\G103	Un\G135	
CH□ Alert set value 3	Un\G40	Un\G72	Un\G104	Un\G136	
CH□ Alert set value 4	Un\G41	Un\G73	Un\G105	Un\G137	

(b) Setting range

The following table lists set values and setting ranges which are available for alert set values set in each alert mode.

Set value	Alert mode	Setting range of alert set value
0	- (no alert)	—
1	Upper limit input alert	Within the temperature measurement range of the set input range ( Page 345, Appendix 2 (12))
2	Lower limit input alert	
3	Upper limit deviation alert	-(full scale) to +(full scale)
4	Lower limit deviation alert	
5	Upper lower limit deviation alert	0 to +(full scale)
6	Within-range alert	
7	Upper limit input alert with standby	Within the temperature measurement range of the set input range ( Page 345, Appendix 2 (12))
8	Lower limit input alert with standby	
9	Upper limit deviation alert with standby	-(full scale) to +(full scale)
10	Lower limit deviation alert with standby	
11	Upper lower limit deviation alert with standby	0 to +(full scale)
12	Upper limit deviation alert with standby (second time)	
13	Lower limit deviation alert with standby (second time)	-(full scale) to +(full scale)
14	Upper lower limit deviation alert with standby (second time)	
15	Upper limit deviation alert (using the set value (SV))	-(full scale) to +(full scale)
16	Lower limit deviation alert (using the set value (SV))	
17	Upper lower limit deviation alert (using the set value (SV))	0 to +(full scale)
18	Within-range alert (using the set value (SV))	

Set value	Alert mode	Setting range of alert set value
19	Upper limit deviation alert with standby (using the set value (SV))	-(full scale) to +(full scale)
20	Lower limit deviation alert with standby (using the set value (SV))	
21	Upper lower limit deviation alert with standby (using the set value (SV))	0 to +(full scale)
22	Upper limit deviation alert with standby (second time) (using the set value (SV))	-(full scale) to +(full scale)
23	Lower limit deviation alert with standby (second time) (using the set value (SV))	
24	Upper lower limit deviation alert with standby (second time) (using the set value (SV))	0 to +(full scale)

(c) Enablement of setting contents

Enable the setting contents by turning Setting change instruction (YnB) OFF → ON → OFF during the setting mode (Setting/operation mode status (Xn1): OFF).

When the set value is out of the range, a write data error (error code: □□□4H) occurs, and the L60TC4 operates with the previous set value. Turning Setting change instruction (YnB) OFF → ON → OFF after the error occurrence and setting a value within the range operate the L60TC4 with the new set value.

(d) Default value

The default values are set to 0 in all channels.

(53)CH□ Process alarm alert output enable/disable setting (Un\G196, Un\G212, Un\G228, Un\G244)

Set whether to enable or disable alert output of process alarm. For details on the process alarm, refer to the following.

 Page 120, Section 8.1.3 (1)

(a) Setting range

- 0: Enable
- 1: Disable

(b) Enablement of setting contents

Enable the setting contents by turning Setting change instruction (YnB) OFF → ON → OFF during the setting mode (Setting/operation mode status (Xn1): OFF).

(c) Default value

The default values are set to Disable (1) in all channels.

(54)CH□ Process alarm lower lower limit value (Un\G197, Un\G213, Un\G229, Un\G245) 

CH□ Process alarm lower upper limit value (Un\G198, Un\G214, Un\G230, Un\G246) 

CH□ Process alarm upper lower limit value (Un\G199, Un\G215, Un\G231, Un\G247) 

CH□ Process alarm upper upper limit value (Un\G200, Un\G216, Un\G232, Un\G248) 

Set the lower lower limit value, lower upper limit value, upper lower value, and upper upper limit of process alarm.

(a) Setting range

The setting range should meet the both of the following.

- Within the temperature measurement range of set input range (☞ Page 345, Appendix 2 (12))
- Process alarm lower lower limit value ≤ Process alarm lower upper limit value ≤ Process alarm upper lower limit value ≤ Process alarm upper upper limit value (If the setting is out of the setting value, out of range error (error code: □□□8H) occurs.)

(b) Setting unit

The value to be set differs depending on the stored value in CH□ Decimal point position (Un\G1 to Un\G4). (☞ Page 334, Appendix 2 (2))

- No decimal place (0): Set a value in 1°C (°F or digit) unit.
- One decimal place (1): Set a value in 0.1°C (°F) unit (tenfold value).

(c) Enablement of setting contents

Enable the setting contents by turning Setting change instruction (YnB) OFF → ON → OFF during the setting mode (Setting/operation mode status (Xn1): OFF).

(d) Default value

Item	Default value	
	L60TCTT4/L60TCTT4BW	L60TCRT4/L60TCRT4BW
CH□ Process alarm lower lower limit value	0	-2000
CH□ Process alarm lower upper limit value	0	-2000
CH□ Process alarm upper lower limit value	1300	6000
CH□ Process alarm upper upper limit value	1300	6000

(55)CH□ Rate alarm alert output enable/disable setting (Un\G201, Un\G217,**Un\G233, Un\G249)** 

Set whether to enable or disable alert output of rate alarm. For details on the rate alarm, refer to the following.

 Page 122, Section 8.1.3 (2)

(a) Setting range

- 0: Enable
- 1: Disable

(b) Enablement of setting contents

Enable the setting contents by turning Setting change instruction (YnB) OFF → ON → OFF during the setting mode (Setting/operation mode status (Xn1): OFF).

(c) Default value

The default values are set to Enable (1) in all channels.

(56)CH□ Rate alarm alert detection cycle (Un\G202, Un\G218, Un\G234,**Un\G250)** 

Set the check cycle of the temperature process value (PV) for the rate alarm. Set the frequency of checks in the unit of sampling cycles.

The check cycle can be calculated from the following formula.

- Rate alarm alert detection cycle = Set value of Rate alarm alert detection cycle × Sampling cycle

(a) Setting range

The setting range is 1 to 6000 (times).

(b) Enablement of setting contents

Enable the setting contents by turning Setting change instruction (YnB) OFF → ON → OFF during the setting mode (Setting/operation mode status (Xn1): OFF).

(c) Default value

The default values are set to Every sampling cycle (1) in all channels.

(57)CH□ Rate alarm upper limit value (Un\G203, Un\G219, Un\G235, Un\G251) Temperature Input

CH□ Rate alarm lower limit value (Un\G204, Un\G220, Un\G236, Un\G252) Temperature Input

Set the rate alarm upper limit value and lower limit value.

(a) Setting range

The setting is -32768 to 32767.

(b) Setting unit

The value to be set differs depending on the stored value in CH□ Decimal point position (Un\G1 to Un\G4).

( Page 334, Appendix 2 (2))

- No decimal place (0): Set a value in 1°C (°F or digit) unit.
- One decimal place (1): Set a value in 0.1°C (°F) unit (tenfold value).

(c) Enablement of setting contents

Enable the setting contents by turning Setting change instruction (YnB) OFF → ON → OFF during the setting mode (Setting/operation mode status (Xn1): OFF).

(d) Default value

The default values are set to 0 in all channels.

(58)CT□ Heater current process value (Un\G256 to Un\G263) Standard Heating-cooling

The heater current value which L60TCTT4BW or L60TCRT4BW detects is stored in this buffer memory area. The current values within the range of the current sensor selected in CT□ CT selection (Un\G272 to Un\G279)



( Page 392, Appendix 2 (60)) is stored.

(a) Supported module

- L60TCTT4BW
- L60TCRT4BW

Point

To perform the measurement of the heater current, the following buffer memory areas need to be set.

- CT□ CT input channel assignment setting (Un\G264 to Un\G271) ( Page 391, Appendix 2 (59))
- CT□ Reference heater current value (Un\G280 to Un\G287) ( Page 393, Appendix 2 (61))

If the both are set to 0, the heater current cannot be measured. If either of them is not set, the heater current cannot be measured precisely.

(59)CT□ CT input channel assignment setting (Un\G264 to Un\G271) Standard Heating-cooling

Set the assignment of each current sensor (CT) input to the channels.

(a) Supported modules

- L60TCTT4BW
- L60TCRT4BW

(b) Correspondence between CT input terminal and buffer memory address

CT input terminal	Buffer memory address
CT1	Un\G264
CT2	Un\G265
CT3	Un\G266
CT4	Un\G267
CT5	Un\G268
CT6	Un\G269
CT7	Un\G270
CT8	Un\G271

(c) Setting range

- 0: Unused
- 1: CH1
- 2: CH2
- 3: CH3
- 4: CH4

(d) Default value

The default values are set to Unused (0) for all terminals.

Point

- If a three-phase heater is used, the same channel should be assigned to two current sensor (CT) inputs.
For setting examples, refer to the following.
 Page 105, Section 6.5
- In the heating-cooling control, CH3 and CH4 cannot be assigned to this setting.
In the mix control, CH2 cannot be assigned to this setting.

(60)CT□ CT selection (Un\G272 to Un\G279) Standard Heating-cooling

Select the current sensor to be connected to each current sensor (CT) input.

(a) Supported modules

- L60TCTT4BW
- L60TCRT4BW

(b) Setting range

- 0: When CTL-12-S36-8 is used (0.0 to 100.0A)
- 1: When CTL-6-P(-H) is used (0.00 to 20.00A)
- 2: When CT ratio setting is used (0.0A to 100.0A)

(c) Current sensor (CT) to be used and buffer memory setting

When using a current sensor (CT) other than CTL-12-S36-8 and CTL-6-P(-H), set the number of second-winding (turns) of the current sensor (CT) to be connected in CT□ CT ratio setting (Un\G288 to Un\G295).
Set the buffer memory area as follows according to the specification of the current sensor (CT) to be used.

Current sensor (CT) to be used		CT□ CT Selection (Un\G272 to Un\G279)	CT□ CT ratio setting (Un\G288 to Un\G295) (☞ Page 393, Appendix 2 (62))	Note
Products of U.R.D.Co., LTD.	CTL-12-S36-8	When CTL-12-S36-8 is used (0.0A to 100.0A) (0)	Setting not necessary	The product is discontinued, though it can be used.
	CTL-6-P	When CTL-6-P(-H) is used (0.00A to 20.00A) (1)	Setting not necessary	
	CTL-6-P-H	When CTL-6-P(-H) is used (0.00A to 20.00A) (1)	Setting not necessary	—
	CTL-12-S36-10	When CT ration setting is used (0.0A to 100.0A) (2)	Set 1000, which is the number of second-winding (turns).	—
	CTL-12-S56-10	When CT ration setting is used (0.0A to 100.0A) (2)	Set 1000, which is the number of second-winding (turns).	—
Other current sensors(CT)		When CT ration setting is used (0.0A to 100.0A) (2)	Set the number of second-winding (turns) depending on the current sensor (CT) specification.	Current sensors (CT) whose number of second-winding (turns) is 600 to 9999 can be used.

For the URL of U.R.D.Co., LTD., refer to the following.

☞ Page 82, Section 5.2 (4)

(d) Enablement of setting contents

Enable the setting contents by turning Setting change instruction (YnB) OFF → ON → OFF during the setting mode (Setting/operation mode status (Xn1): OFF).

(e) Occurrence of write data error

In the following case, a write data error (error code: □□□4_H) occurs as when the setting is out of the setting value. Error occurrence flag (Xn2) turns on and the error code is stored in Error code (Un\G0).

- When the set value of CT□ CT ratio setting (Un\G288 to Un\G295) is out of the setting when Setting change instruction (YnB) is turned OFF → ON → OFF

(f) Default value

The default values are set to When CTL-12-S36-8 is used (0.0 to 100.0A) (0) for all terminals.



When CT ratio setting is used (0.0 to 100.0A) (2) is selected, the setting of CT□ CT ratio setting (Un\G288 to Un\G295) is enabled. In advance, set CT□ CT ratio setting (Un\G288 to Un\G295) corresponding to the sensor to be connected. After that, select When CT ratio setting is used (0.0 to 100.0A) (2).

(61)CT□ Reference heater current value (Un\G280 to Un\G287) Standard Heating-cooling

Set the reference value of CT□ Heater current process value (Un\G256 to Un\G263) of when the heater is turned on (☞ Page 390, Appendix 2 (58)).

(a) Supported modules

- L60TCTT4BW
- L60TCRT4BW

(b) Setting range

The setting range is within the heater current range of the current sensor selected in CT□ CT selection (Un\G272 to Un\G279). (☞ Page 392, Appendix 2 (60))

Setting range	Setting of CT□ CT selection (Un\G272 to Un\G279)
0 to 1000 (0.0 to 100.0A)	<ul style="list-style-type: none"> • When CTL-12-S36-8 is used (0.0 to 100.0A) (0) • When CT ratio setting is used (0.0 to 100.0A) (2)
0 to 2000 (0.00 to 20.00A)	When CTL-6-P(-H) is used (0.00 to 20.00A) (1)

(c) Default value

The default values are set to 0 (0.0A) for all terminals.

(62)CT□ CT ratio setting (Un\G288 to Un\G295) Standard Heating-cooling

Set the number of second-winding (turning number) of the current sensor (CT) to be connected.

This buffer memory area is available only when CT□ CT selection (Un\G272 to Un\G279) is set to When CT ratio setting is used (0.0 to 100.0A) (2). (☞ Page 392, Appendix 2 (60))

(a) Supported modules

- L60TCTT4BW
- L60TCRT4BW

(b) Setting range

The setting range is 600 to 9999.

(c) Default value

The default values are set to 800 for all terminals.

(63)CH□ 2-point sensor compensation offset value (measured value) (Un\G544,

Un\G576, Un\G608, Un\G640) **Common**

The measured value of temperature corresponding to the offset value of the 2-point sensor compensation is stored in this buffer memory area.

The value to be stored differs depending on the stored value in CH□ Decimal point position (Un\G1 to Un\G4).

( Page 334, Appendix 2 (2))

- No decimal place (0): stored as it is.
- One decimal place (1): stored after a multiplication by 10.

For details on the 2-point sensor compensation function, refer to the following.

( Page 227, Section 8.3.2 (2))

(a) Enablement of the stored value

Turn Setting change instruction (YnB) OFF → ON → OFF during the setting mode (Setting/operation mode status (Xn1): OFF) to enable stored contents.

(64)CH□ 2-point sensor compensation offset value (compensation value)

(Un\G545, Un\G577, Un\G609, Un\G641) **Common**

Set the temperature of the offset value of the 2-point sensor compensation.

For details on the 2-point sensor compensation function, refer to the following.

( Page 227, Section 8.3.2 (2))

(a) Setting range

The setting range is identical to the temperature measurement range of the set input range. ( Page 345, Appendix 2 (12))

(b) Setting unit

The value to be set differs depending on the stored value in CH□ Decimal point position (Un\G1 to Un\G4).

( Page 334, Appendix 2 (2))

- No decimal place (0): Set a value in 1°C (°F or digit) unit.
- One decimal place (1): Set a value in 0.1°C (°F) unit (tenfold value).

(c) Enablement of setting contents

Enable the setting contents by turning Setting change instruction (YnB) OFF → ON → OFF during the setting mode (Setting/operation mode status (Xn1): OFF).

(d) Default value

The default values are set to 0 in all channels.

(65)CH□ 2-point sensor compensation gain value (measured value) (Un\G546,**Un\G578, Un\G610, Un\G642)** **Common**

The measured value of temperature corresponding to the gain value of the 2-point sensor compensation is stored in this buffer memory area.

The value to be stored differs depending on the stored value in CH□ Decimal point position (Un\G1 to Un\G4).

( Page 334, Appendix 2 (2))

- No decimal place (0): stored as it is.
- One decimal place (1): stored after a multiplication by 10.

For details on the 2-point sensor compensation function, refer to the following.

( Page 227, Section 8.3.2 (2))

(a) Enablement of the stored value

Turn Setting change instruction (YnB) OFF → ON → OFF during the setting mode (Setting/operation mode status (Xn1): OFF) to enable stored contents.

(66)CH□ 2-point sensor compensation gain value (compensation value) (Un\G547,**Un\G579, Un\G611, Un\G643)** **Common**

Set temperature of gain value of the 2-point sensor compensation.

For details on the 2-point sensor compensation function, refer to the following.

( Page 227, Section 8.3.2 (2))

(a) Setting range

The setting range is identical to the temperature measurement range of the set input range. ( Page 345, Appendix 2 (12))

(b) Setting unit

The value to be set differs depending on the stored value in CH□ Decimal point position (Un\G1 to Un\G4).

( Page 334, Appendix 2 (2))

- No decimal place (0): Set a value in 1°C (°F or digit) unit.
- One decimal place (1): Set a value in 0.1°C (°F) unit (tenfold value).

(c) Enablement of setting contents

Enable the setting contents by turning Setting change instruction (YnB) OFF → ON → OFF during the setting mode (Setting/operation mode status (Xn1): OFF).

(d) Default value

The default values are set to 0 in all channels.

(67)CH□ 2-point sensor compensation offset latch request (Un\G548, Un\G580, Un\G612, Un\G644) Common

This request is for storing temperature process value (PV) as 2-point sensor compensation offset value to the following buffer memory area.

- CH□ 2-point sensor compensation offset value (measured value) (Un\G544, Un\G576, Un\G608, Un\G640)
( Page 394, Appendix 2 (63))

For details on the 2-point sensor compensation function, refer to the following.

( Page 227, Section 8.3.2 (2))

(a) Setting range

- 0: No request
- 1: Latch request

(b) Default value

The default values are set to No request (0) in all channels.

(68)CH□ 2-point sensor compensation offset latch completion (Un\G549, Un\G581, Un\G613, Un\G645) Common

When 2-point sensor compensation offset value is stored, 1 is stored in this buffer memory area, which is Latch completed (1).

When CH□ 2-point sensor compensation offset latch request (Un\G548, Un\G580, Un\G612, Un\G644) is set to No request (0), 0 is stored in this buffer memory area, which is No request (0). ( Page 396, Appendix 2 (67))

For details on the 2-point sensor compensation function, refer to the following.

( Page 227, Section 8.3.2 (2))

(69)CH□ 2-point sensor compensation gain latch request (Un\G550, Un\G582,**Un\G614, Un\G646)** Common

This is a request for storing temperature process value (PV) as 2-point sensor compensation gain value to the following buffer memory area.

- CH□ 2-point sensor compensation gain value (measured value) (Un\G546, Un\G578, Un\G610, Un\G642)

( Page 395, Appendix 2 (65))

For details on the 2-point sensor compensation function, refer to the following.

( Page 227, Section 8.3.2 (2))

(a) Setting range

- 0: No request
- 1: Latch request

(b) Default value

The default values are set to No request (0) in all channels.

(70)CH□ 2-point sensor compensation gain latch completion (Un\G551, Un\G583,**Un\G615, Un\G647)** Common

When 2-point sensor compensation gain value is stored, 1 is stored in this buffer memory area, which is Latch completed (1).

When CH□ 2-point sensor compensation gain latch request (Un\G550, Un\G582, Un\G614, Un\G646) is set to No request (0), 0 is stored in this buffer memory area, which is No request (0). ( Page 397, Appendix 2 (69))

For details on the 2-point sensor compensation function, refer to the following.

( Page 227, Section 8.3.2 (2))

(71)CH□ AT simultaneous temperature rise parameter calculation flag (Un\G573,

Un\G605, Un\G637, Un\G669) **Standard**

The status when simultaneous temperature rise AT (auto tuning) calculates simultaneous temperature rise parameter is stored in this buffer memory area.

- 0: OFF
- 1: ON

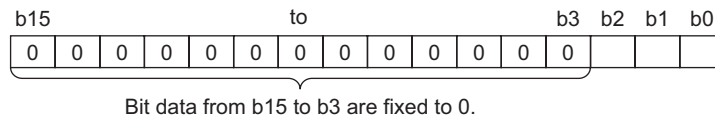

Bit	Flag name	Description
b0	AT simultaneous temperature rise parameter calculation completion	This flag is set to 1 (ON) when the simultaneous temperature rise parameter ^{*1} is calculated by simultaneous temperature rise AT.
b1	AT simultaneous temperature rise parameter calculation error status	This flag is set to 1 (ON) when the simultaneous temperature rise parameter ^{*1} cannot be calculated by simultaneous temperature rise AT.
b2	Simultaneous temperature rise AT disable status	This flag is set to 1 (ON) when the simultaneous temperature rise AT cannot be performed.
b3 to b15	- (fixed to 0)	- (Unused)

*1 Indicates the values of CH□ Simultaneous temperature rise gradient data (Un\G731, Un\G747, Un\G763, Un\G779) and CH□ Simultaneous temperature rise dead time (Un\G732, Un\G748, Un\G764, Un\G780).

Point

This area is enabled only for the following channels (channels of the standard control).

- CH1 to CH4 when the standard control is used
- CH3 and CH4 when mix control (normal mode) or mix control (expanded mode) is used

For details on the simultaneous temperature rise function, refer to the following.

Page 190, Section 8.2.17

(72)CH□ Self-tuning setting (Un\G574, Un\G606, Un\G638, Un\G670) Standard

Perform operation setting of self-tuning with this buffer memory area.

For details on the self-tuning function, refer to the following.

 Page 175, Section 8.2.15

(a) Setting range

- 0: Do Not Run the ST
- 1: Starting ST (PID Constants Only)
- 2: Starting ST (Simultaneous Temperature Rise Parameter Only^{*1})
- 3: Starting ST (PID constants and Simultaneous Temperature Rise Parameter^{*1})
- 4: Starting ST and vibration ST (PID Constants Only)

*1 Indicates the values of CH□ Simultaneous temperature rise gradient data (Un\G731, Un\G747, Un\G763, Un\G779) and CH□ Simultaneous temperature rise dead time (Un\G732, Un\G748, Un\G764, Un\G780) to be used in the simultaneous temperature rise function.

For details on the simultaneous temperature rise function, refer to the following.

 Page 190, Section 8.2.17

(b) Default value

The default values are set to Do Not Run the ST (0) in all channels.

Point 

This area is enabled only for the following channels (channels of the standard control).

- CH1 to CH4 when the standard control is used
- CH3 and CH4 when mix control (normal mode) or mix control (expanded mode) is used

(73)CH□ Self-tuning flag (Un\G575, Un\G607, Un\G639, Un\G671) Standard

The execution status of self-tuning can be monitored in this buffer memory area.

For details on the self-tuning function, refer to the following.

Page 175, Section 8.2.15

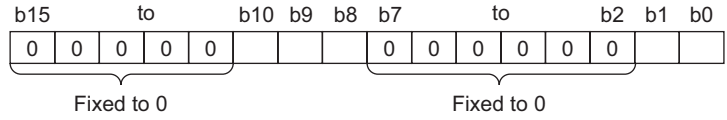

The following contents are stored in each bit.

- 0: OFF
- 1: ON

Bit	Flag name	Condition on which value turns to 1 (ON)	Condition on which value turns to 0 (OFF)
b0	PID auto-correction status	This flag is set to 1 (ON) when PID constants are corrected by the self-tuning.	This flag is set to 0 (OFF) when either of the following operation is performed. <ul style="list-style-type: none"> • When the operation mode shifts to the setting mode by turning off from on Setting/operation mode instruction (Yn1) • When CH□ Unused channel setting (Un\G61, Un\G93, Un\G125, Un\G157) is set to Unused (1) • When CH□ PID control forced stop instruction (YnC to YnF) is turned on from off • When CH□ Self-tuning setting (Un\G574, Un\G606, Un\G638, Un\G670) is set to Do not run the ST (0)
b1	Simultaneous temperature rise parameter correction status	This flag is set to 1 (ON) when simultaneous temperature rise parameter*1 is corrected by self-tuning.	This flag is also set to 0 (OFF) in the following cases. <ul style="list-style-type: none"> • When the self-tuning starts by changing the set value (SV) • When the vibration ST starts by vibration caused by disturbance of the process value (PV)
b2 to b7	- (fixed to 0)	- (Unused)	—
b8	Self-tuning disable status	This flag is set to 1 (ON) when the self-tuning cannot be performed.	This flag is set to 0 (OFF) when either of the following operation is performed. <ul style="list-style-type: none"> • When the operation mode shifts to the setting mode by turning off from on Setting/operation mode instruction (Yn1) • When CH□ Unused channel setting (Un\G61, Un\G93, Un\G125, Un\G157) is set to Unused (1) • When CH□ PID control forced stop instruction (YnC to YnF) is turned on from off • When CH□ Self-tuning setting (Un\G574, Un\G606, Un\G638, Un\G670) is set to Do not run the ST (0) This flag is also set to 0 (OFF) when all disable conditions are released. For disable conditions, refer to Page 181, Section 8.2.15 (6).

Bit	Flag name	Condition on which value turns to 1 (ON)	Condition on which value turns to 0 (OFF)
b9	Simultaneous temperature rise parameter error status	This flag is set to 1 (ON) when simultaneous temperature rise parameter ^{*1} cannot be calculated by self-tuning.	
b10	Self-tuning error	<p>This flag is set to 1 (ON) when either of the following operation is performed during the self-tuning.</p> <ul style="list-style-type: none"> • PID constants change • Setting change rate limiter change • Output limiter change • Control output cycle change • Sensor correction change • Primary delay digital filter change • AUTO to MAN mode shift • Forward/reverse action shift <p>This flag is also set to 1 (ON) in the following cases</p> <ul style="list-style-type: none"> • When the temperature process value (PV) is out of the temperature measurement range • When required measurement data is not obtained because the manipulated value (MV) does not reach the upper limit output limiter value or the lower limit output limiter value until the measurement is completed • When the temperature process value (PV) decreases by 1°C (°F) or more though it should increase after the self-tuning is started as the starting ST • When temperature process value (PV) increases by 1°C (°F) or more though it should decrease after the self-tuning is started as the starting ST 	<p>This flag is set to 0 (OFF) when either of the following operation is performed.</p> <ul style="list-style-type: none"> • When the operation mode shifts to the setting mode by turning off from on Setting/operation mode instruction (Yn1) • When CH□ Unused channel setting (Un\G61, Un\G93, Un\G125, Un\G157) is set to Unused (1) • When CH□ PID control forced stop instruction (YnC to YnF) is turned on from off • When CH□ Self-tuning setting (Un\G574, Un\G606, Un\G638, Un\G670) is set to ST(0) <p>This flag is also set to 0 (OFF) in the following cases.</p> <ul style="list-style-type: none"> • When the self-tuning starts by changing the set value (SV) • When the vibration ST starts by vibration caused by disturbance of the process value (PV)
b11 to b15	- (fixed to 0)	- (Unused)	—

*1 Indicates the values of CH□ Simultaneous temperature rise gradient data (Un\G731, Un\G747, Un\G763, Un\G779) and CH□ Simultaneous temperature rise dead time (Un\G732, Un\G748, Un\G764, Un\G780).
For details on the simultaneous temperature rise function, refer to  Page 190, Section 8.2.17.

Point

This area is enabled only for the following channels (channels of the standard control).

- CH1 to CH4 when the standard control is used
- CH3 and CH4 when mix control (normal mode) or mix control (expanded mode) is used

(74)CH□ Temperature process value (PV) for input with another analog module

(Un\G689 to Un\G692) **Standard** **Heating-cooling**

Digital input value of the current/voltage converted in another analog module (such as A/D conversion module) on system can be used as a temperature process value (PV).

Store digital input values of current/voltage converted by another analog module (such as A/D conversion module) in this area.

For details, refer to the following.

 Page 172, Section 8.2.13 (1)

Point

If a stored value is out of the set input range, the value to be used in control is fixed to the upper limit value or the lower limit value of the input range.

(75)Conversion enable/disable setting (Un\G693) **Temperature Input**

Set enable or disable temperature input. For details on the temperature input function, refer to the following.

 Page 116, Section 8.1

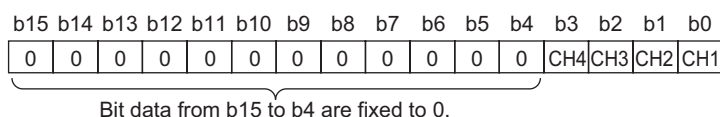

(a) Setting range

- 0: Enable
- 1: Disable

(b) Enablement of setting contents

Enable the setting contents by turning Setting change instruction (YnB) OFF → ON → OFF during the setting mode (Setting/operation mode status (Xn1): OFF).

(c) Default value

All channels are set to Conversion disable (000F_H).

(76)CH□ Temperature conversion setting (Un\G695 to Un\G697) 

In the heating-cooling control (normal mode) or the mix control (normal mode), only the temperature measurement can be performed using temperature input terminals of unused channels.

The following table lists the settable buffer memory addresses for each control mode selection.

Channel	Control mode				
	Standard control	Heating-cooling control (normal mode)	Heating-cooling control (expanded mode)	Mix control (normal mode)	Mix control (expanded mode)
CH1	—	—	—	—	—
CH2	—	—	—	Un\G695	—
CH3	—	Un\G696	—	—	—
CH4	—	Un\G697	—	—	—

When the combination of the control mode and the buffer memory address is not the setting target in the above list, the combination is invalid even if it is set.

For details on the temperature conversion function (using unused channels), refer to the following.

 Page 212, Section 8.2.23

(a) Setting range

- 0: Not use
- 1: Use

(b) Default value

The default values are set to Not use (0) in all channels.

Point 

- When this setting is set from Not use (0) to Use (1), after completion of the first temperature conversion, Temperature conversion completion flag (Un\G786) is set to First temperature conversion completed (1_H). Before referring to the temperature process value (PV) of each channel, check Temperature conversion completion flag (Un\G786) has been set to First temperature conversion completed (1_H).
- When the following control mode is selected, this setting is invalid.
 - Standard control
 - Heating-cooling control (expanded mode)
 - Mix control (expanded mode)

(77)Cooling method setting (Un\G719) Heating-cooling

Set the method for the cooling control in the heating-cooling control. Select the suitable cooling method for cooling characteristics of devices.

The following figure shows the channel assignment of the buffer memory area.

b15 to b12	b11 to b8	b7 to b4	b3 to b0
CH4	CH3	CH2	CH1

For details on the cooling method setting function, refer to the following.

 Page 207, Section 8.2.21

(a) Setting range

- 0_H: Air cooling
- 1_H: Water cooling
- 2_H: Linear

(b) Enablement of setting contents

Enable the setting contents by turning Setting change instruction (YnB) OFF → ON → OFF during the setting mode (Setting/operation mode status (Xn1): OFF).

(c) Default value

The default value is set to Air cooling (0_H).

(78)CH□ Overlap/dead band function (Un\G723, Un\G739, Un\G755,

Un\G771) Heating-cooling

Configure the overlap/dead band setting.

For details on the overlap/dead band function, refer to the following.

 Page 209, Section 8.2.22

(a) Setting range

Set the value within the following ranges for the full scale of the set input range. ( Page 345, Appendix 2 (12))

- -100 to -1 (-10.0% to -0.1%): Overlap
- 0(0.0%): None
- 1 to 100 (0.1% to 10.0%): Dead band

(b) Default value

The default values are set to 0 (0.0%) in all channels.

(79)CH□ Manual reset amount setting (Un\G724, Un\G740, Un\G756, Un\G772)**Standard** **Heating-cooling**

Set the amount of the proportional band (P) to be moved.
For details on the manual reset function, refer to the following.

 Page 137, Section 8.2.4

(a) Setting range

Set the value within the range of -1000 to 1000 (-100.0% to 100.0%) for the full scale of the set input range.

 Page 345, Appendix 2 (12))

The setting range is the same between the standard control and heating-cooling control.

(b) Default value

The default values are set to 0 (0.0%) in all channels. The default value is the same between the standard control and the heating-cooling control.

(80)CH□ Process value (PV) scaling function enable/disable setting (Un\G725,**Un\G741, Un\G757, Un\G773)** **Common**

Set enable/disable of the temperature process value (PV) scaling function.
For details on the temperature process value (PV) scaling function, refer to the following.

 Page 221, Section 8.3.1

(a) Setting range

- 0: Disable
- 1: Enable

(b) Enablement of setting contents

Enable the setting contents by turning Setting change instruction (YnB) OFF → ON → OFF during the setting mode (Setting/operation mode status (Xn1): OFF).

(c) Default value

The default values are set to Disable (0) in all channels.

(81)CH□ Process value (PV) scaling lower limit value (Un\G726, Un\G742, Un\G758, Un\G774) Common

CH□ Process value (PV) scaling upper limit value (Un\G727, Un\G743, Un\G759, Un\G775) Common

Set the upper limit value/lower limit value of the temperature process value (PV) scaling function.

For details on the temperature process value (PV) scaling function, refer to the following.

 Page 221, Section 8.3.1

(a) Setting range

The setting range is -32000 to 32000.

(b) Enablement of setting contents

Enable the setting contents by turning Setting change instruction (YnB) OFF → ON → OFF during the setting mode (Setting/operation mode status (Xn1): OFF).

(c) Default value

The default values are set to 0 in all channels.

Point 

The setting where the lower limit value is not less than the upper limit value does not cause an error. The temperature process value (PV) is scaled according to the formula of  Page 221, Section 8.3.1 (1).

(82)CH□ Process value (PV) scaling value (Un\G728, Un\G744, Un\G760, Un\G776) Common

When the temperature process value (PV) scaling function is enabled, the scaled temperature process value (PV) is stored.

For details on the temperature process value (PV) scaling function, refer to the following.

 Page 221, Section 8.3.1

(83)CH□ Derivative action selection (Un\G729, Un\G745, Un\G761, Un\G777)**Standard** Heating-cooling

Select the type of derivative action. Dynamic performance can be improved by selecting the suitable derivative action for the fixed value action and the ramp action. For details on the derivative action selection function, refer to the following.

 Page 154, Section 8.2.9

(a) Setting range

- 0: Measured value derivation
- 1: Deviation derivation

(b) Enablement of setting contents

Enable the setting contents by turning Setting change instruction (YnB) OFF → ON → OFF during the setting mode (Setting/operation mode status (Xn1): OFF).

(c) Default value

All channels are set to Measured value derivation (0).

(84)CH□ Simultaneous temperature rise group setting (Un\G730, Un\G746,**Un\G762, Un\G778)** **Standard**

Set a group to perform the simultaneous temperature rise function for each channel. The simultaneous temperature rise function enables channels in the same group to complete the rise of temperature simultaneously. When the control mode is the heating-cooling control, this setting is invalid.

For details on the simultaneous temperature rise function, refer to the following.

 Page 190, Section 8.2.17

(a) Setting range of the standard control

- 0: No simultaneous temperature rise
- 1: Group 1 selection
- 2: Group 2 selection

(b) Setting range of the mix control

- 0: No simultaneous temperature rise
- 1: Simultaneous temperature rise

The setting range in the mix control does not include group selection because the mix control has only two channels for the standard control.

(c) Enablement of setting contents

Enable the setting contents by turning Setting change instruction (YnB) OFF → ON → OFF during the setting mode (Setting/operation mode status (Xn1): OFF).

(d) Default value

The default values are set to No simultaneous temperature rise (0) in all channels.

(85)CH□ Simultaneous temperature rise gradient data (Un\G731, Un\G747, Un\G763, Un\G779) Standard

Set Simultaneous temperature rise gradient data (temperature rising per minute).

For details on the simultaneous temperature rise function, refer to the following.

 Page 190, Section 8.2.17

(a) Setting range

The setting range is 0 to (the upper limit of the temperature measurement range of the set input range).

(b) Setting unit

The value to be set differs depending on the stored value in CH□ Decimal point position (Un\G1 to Un\G4).

 Page 334, Appendix 2 (2))

- No decimal place (0): Set a value in 1°C (°F or digit) unit.
- One decimal place (1): Set a value in 0.1°C (°F) unit (tenfold value).

(c) Default value

The default values are set to 0 in all channels.

Point

This setting can not only be set manually but also be calculated automatically. Automatic calculation is performed when the simultaneous temperature rise AT (auto tuning) or self-tuning (when the automatic calculation of the temperature rise parameter is set) is normally completed.

(86)CH□ Simultaneous temperature rise dead time (Un\G732, Un\G748, Un\G764, Un\G780) Standard

Set Simultaneous temperature rise dead time (time taken for the temperature to start rising after the output is turned on).

For details on the simultaneous temperature rise function, refer to the following.

 Page 190, Section 8.2.17

(a) Setting range

The setting range is 0 to 3600 (s).

(b) Default value

The default values are set to 0 in all channels.

Point

This setting can not only be set manually but also be calculated automatically. Automatic calculation is performed when the simultaneous temperature rise AT (auto tuning) or self-tuning (when the automatic calculation of the temperature rise parameter is set) is normally completed.

(87)CH□ Simultaneous temperature rise AT mode selection (Un\G733, Un\G749,**Un\G765, Un\G781)** **Standard**

Select mode of the auto tuning.

For details on the auto tuning function, refer to the following.

 Page 141, Section 8.2.7

For details on the simultaneous temperature rise function, refer to the following.

 Page 190, Section 8.2.17

(a) Setting range

- 0: Select normal auto tuning
- 1: Simultaneous temperature rise AT

(b) Default value

The default values are set to Select normal auto tuning (0) in all channels.

Point 

-
- This setting can be used with the setting of CH□ Auto tuning mode selection (Un\G184 to Un\G187). ( Page 385, Appendix 2 (51))
 - If this setting is changed during the auto tuning, it is enabled in the next auto tuning.
-

(88)CH□ Simultaneous temperature rise status (Un\G734, Un\G750, Un\G766,

Un\G782) Standard

The execution state of the simultaneous temperature rise is monitored. The following values are stored in this buffer memory area.

- 0: Simultaneous temperature rise not in process
- 1: Simultaneous temperature rise in process

During control by the simultaneous temperature rise function, Simultaneous temperature rise in process (1) is stored in this buffer memory area.

The following figure shows the timing when the value is set to Simultaneous temperature rise not in process (0).

(In the following, CH1 and CH2 are set to group 1. (☞ Page 407, Appendix 2 (84))

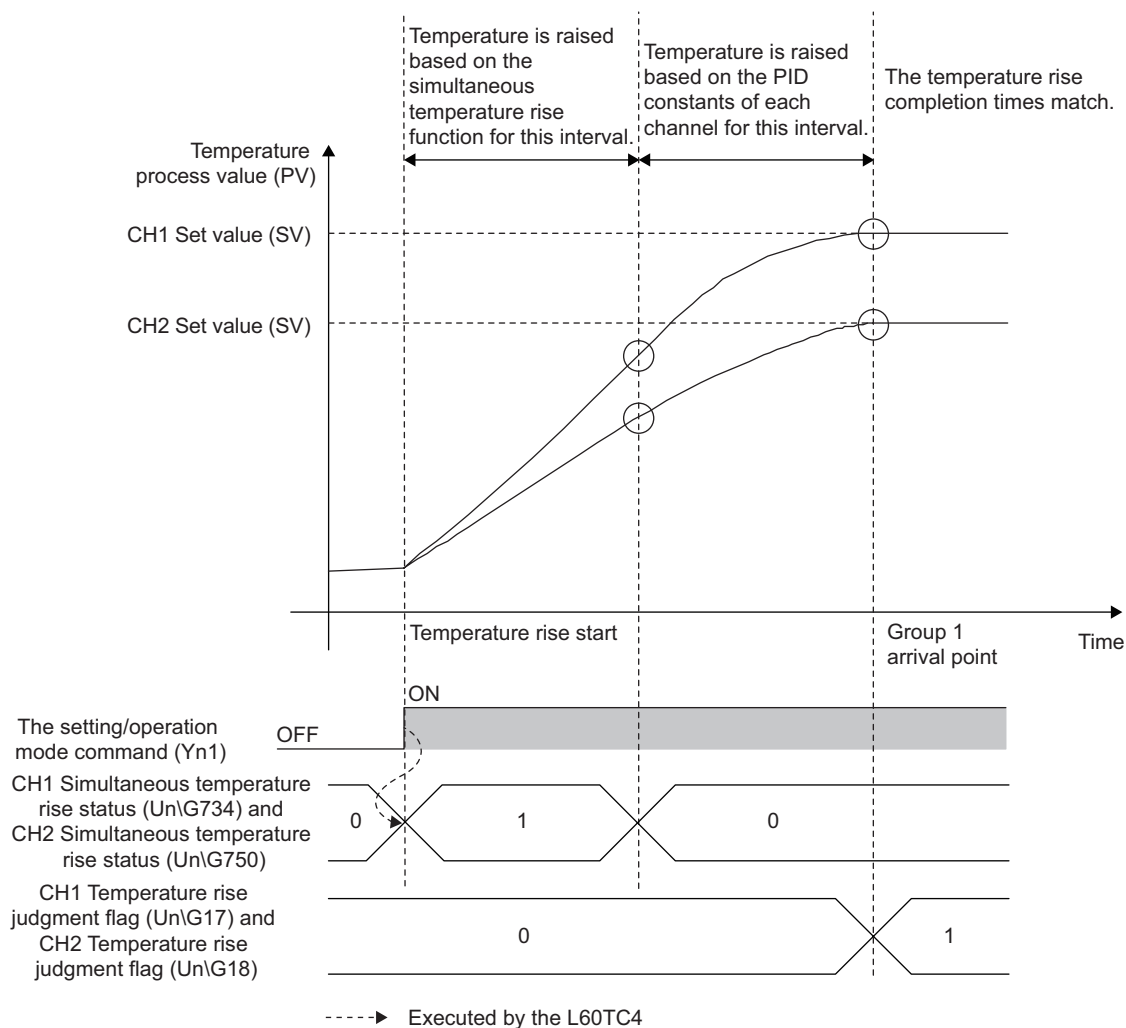

Completion of the temperature rise does not set CH□ Simultaneous temperature rise status (Un\G734, Un\G750, Un\G766, Un\G782) to Simultaneous temperature rise not in process (0). As in the figure above, the temperature rise is performed by the simultaneous temperature rise function to a certain point, and Simultaneous temperature rise in process (1) is set during the performance. After the point, the temperature rise is performed based on the PID constants of each channel, and Simultaneous temperature rise not in process (0) is set.

For details on the simultaneous temperature rise function, refer to the following.

☞ Page 190, Section 8.2.17

(89)CH□ Setting change rate limiter time unit setting (Un\G735, Un\G751, Un\G767,**Un\G783)** **Standard** **Heating-cooling**

Set the time unit of setting change rate limiter.

For details on the setting change rate limiter time unit setting function, refer to the following.

 Page 155, Section 8.2.10

(a) Setting range

- 0 (Not use time unit setting)
- 1 to 3600 (1 to 3600s)

(b) Enablement of setting contents

Enable the setting contents by turning Setting change instruction (YnB) OFF → ON → OFF during the setting mode (Setting/operation mode status (Xn1): OFF).

(c) Default value

The default values are set to 0 (Not use time unit setting) in all channels.

Remark

When 0 is set, the L60TC4 operation is the same as the case when 60, a variation per minute, is set.

A

(90) Peak current suppression control group setting (Un\G784) Standard

Set the target channels for the peak current suppression function and the gap of the control output cycle between channels.

b15 to b12	b11 to b8	b7 to b4	b3 to b0
CH4	CH3	CH2	CH1

For details on the peak current suppression function, refer to the following.

 Page 185, Section 8.2.16

(a) Setting range

- 0_H: Not divide
- 1_H: Group 1
- 2_H: Group 2
- 3_H: Group 3
- 4_H: Group 4

(b) Enablement of setting contents

Enable the setting contents by turning Setting change instruction (YnB) OFF → ON → OFF during the setting mode (Setting/operation mode status (Xn1): OFF).

(c) Default value

The default value is set to Not divide (0_H).

Point

The upper limit output limiter value is automatically set since the division number depends on this setting. The following table lists the upper limit output limiter values which are set when this setting is enabled.

Division Number	CH□ Upper limit output limiter (Un\G42, Un\G74, Un\G106, Un\G138)  Page 360, Appendix 2 (19))
2	500 (50.0%)
3	333 (33.3%)
4	250 (25.0%)

CH□ Lower limit output limiter (Un\G43, Un\G75, Un\G107, Un\G139) is set to 0.

(91) Sensor compensation function selection (Un\G785) Common

Select the method of the sensor correction for each channel.

b15 to b12	b11 to b8	b7 to b4	b3 to b0
CH4	CH3	CH2	CH1

For details on the sensor compensation function, refer to the following.

Page 223, Section 8.3.2

(a) Setting range

- 0_H: 1-point sensor compensation (standard)
- 1_H: 2-point sensor compensation

(b) Enablement of setting contents

Enable the setting contents by turning Setting change instruction (YnB) OFF → ON → OFF during the setting mode (Setting/operation mode status (Xn1): OFF).

(c) Default value

The default value is set to 1-point sensor compensation (standard) (0_H).

(92) Temperature conversion completion flag (Un\G786) Common

This flag checks whether the temperature conversion has started properly for each channel. The following values are stored in this buffer memory area.

- 0_H: During conversion or unused CH
- 1_H: First temperature conversion completed

This flag becomes During conversion or unused CH (0_H) during temperature conversion or for unused channels.

When the first temperature conversion is completed and the temperature process value (PV) is stored in the buffer memory, First temperature conversion completed (1_H) is set.

The following figure shows the channel assignment of this area.

b15 to b12	b11 to b8	b7 to b4	b3 to b0
CH4	CH3	CH2	CH1

(93)Function extension bit monitor (Un\G787) Common

The following settings configured on Switch Setting are stored.



- "Auto-setting at Input Range Change"
- "Setting Change Rate Limiter Setting"
- "Control Output Cycle Unit Selection Setting"

For details on Switch Setting, refer to the following.

 Page 108, Section 7.2

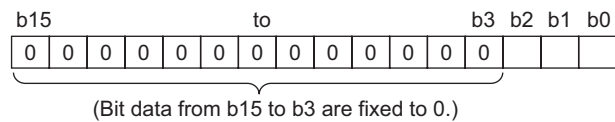
The following figure and table show how the setting is stored.



Bit	Flag name (Function extension bit monitor)	Description
b0	Auto-setting at Input Range Change	When the input range is changed, the related buffer memory data is automatically changed to prevent errors of the buffer memory areas that are out of the setting range. ( Page 351, Appendix 2 (12) (d)) 0: Disable 1: Enable
b1	Setting Change Rate Limiter Setting	Select whether the setting change rate limiter to be set in a batch or individually. ( Page 155, Section 8.2.10) 0: Temperature Rise/Temperature Drop Batch Setting 1: Temperature Rise/Temperature Drop Individual Setting
b2	Control Output Cycle Unit Selection Setting	Select 0.1s or 1s as a unit for the cycle of turning on/off the transistor output. ( Page 140, Section 8.2.6) 0: 1s Cycle 1: 0.1s Cycle
b3 to b15	- (fixed to 0)	- (Unused)

(94)Sampling cycle monitor (Un\G788) Common

Current sampling cycle is stored.

- 0: 500ms/4 channels
- 1: 250ms/4 channels

Sampling cycle is set on Switch Setting. For details on Switch Setting, refer to the following.

 Page 108, Section 7.2

(95) Latest address of error history (Un\G1279) Common

The latest address of error history is stored.

For details on the error history function, refer to the following.

 Page 237, Section 8.3.5

(96) Error history 1 to 16 (Un\G1280 to Un\G1407) Common

Errors and alarms occurred in the module are recorded up to 16.

Ex. For the error history 1

Buffer memory address	b15	to	b8 b7	to	b0
Un\G1280	Error code ^{*1}				
Un\G1281	First two digits of the year			Last two digits of the year	
Un\G1282	Month			Day	
Un\G1283	Hour			Minute	
Un\G1284	Second			Day of the week ^{*2}	
Un\G1285	System area				
to					
Un\G1287					

*1 For error codes and alarm codes, refer to the following.

 Page 315, Section 11.6, Page 318, Section 11.7

*2 The following table lists the stored value and corresponding each day of the week.

Stored value	Day of the week
0	Sunday
1	Monday
2	Tuesday
3	Wednesday
4	Thursday
5	Friday
6	Saturday

For details on the error history function, refer to the following.



 Page 237, Section 8.3.5

A

Appendix 2 Details of the Buffer Memory

Appendix 3 How to Check the Serial Number and Function Version

For details on how to check the serial number and function version, refer to the following.

-  MELSEC-L CPU Module User's Manual (Hardware Design, Maintenance and Inspection)
-  MELSEC-L CC-Link IE Field Network Head Module User's Manual

Appendix 4 Differences with MELSEC-Q series Modules

Appendix 4.1 Differences with temperature control modules

This section describes the differences in functions and programming methods between the MELSEC-Q series temperature control modules (Q64TCTTN, Q64TCTTBWN, Q64TCRTN, Q64TCRTBWN) and the L60TC4.

(1) Functional comparison

(a) Added functions

The following table lists the functions added in the L60TC4.

Item	Description	Reference
Input range	The following input ranges are available in the L60TC4. (1) L60TCTT4, L60TCTT4BW • K: -200.0 to 1300.0°C • J: -200.0 to 1000.0°C • E: -200.0 to 1000.0°C • N: 0.0 to 1000.0°C (2) L60TCRT4, L60TCRT4BW • Pt100: -200.0 to 850.0°C • JPt100: -200.0 to 640.0°C	Page 36, Section 3.2.2
Temperature input mode	The L60TC4 can be used as a temperature input module. It also enables application of the primary delay digital filter to temperature input, the alert output, and other functions.	Page 116, Section 8.1
Switching the sampling cycle	The sampling cycle can be selected from 250ms/4 channels and 500ms/4 channels. (The cycle is fixed to 500ms in MELSEC-Q series temperature control modules.)	Page 38, Section 3.2.3 (1), Page 108, Section 7.2
Switching the unit of control output cycle	The control output cycle can be selected by 0.1s (0.5s to 100.0s) with the L60TC4. The cycle can be also selected by 1s (1s to 100s) similar to MELSEC-Q series temperature control modules.	Page 38, Section 3.2.3 (2), Page 108, Section 7.2

(b) Function that cannot be used

Online module change is not available with the L60TC4.

A

(2) Program compatibility

Programs used in the MELSEC-Q series temperature control modules (Q64TCTTN, Q64TCTTBWN, Q64TCRTN, Q64TCRTBWN) can be used with the L60TC4.

(a) I/O signal

Although some I/O numbers of the L60TC4 have different names from those of the MELSEC-Q series temperature control modules, they have the same function and are compatible with each other.

(b) Buffer memory

Although some buffer memory areas have been added to the L60TC4, the functions are the same and the program has compatibility.

(c) Sampling cycle

For the L60TC4, the sampling cycle can be selected from 250ms and 500ms. For the MELSEC-Q series temperature control modules, the cycle is fixed to 500ms. When using the program used in the MELSEC-Q series temperature control modules with the L60TC4, check that the sampling cycle for the L60TC4 is set to 500ms. When changing the cycle to 250ms, thoroughly verify that the control of the target system has no problem.

Appendix 5 When Using GX Developer

This section describes how to configure the setting of the L60TC4 using GX Developer.

Appendix 5.1 I/O assignment and intelligent function module switch setting

Configure the setting on the following windows when using GX Developer.

Window name	Application
I/O assignment	Set the type of a module to be connected and the range of I/O signal.
Intelligent function module switch setting	Configure the Switch Setting of the intelligent function module.

(1) I/O assignment

Configure the setting on "I/O assignment" in "PLC parameter".

 Parameter ⇨ [PLC parameter] ⇨ [I/O assignment]

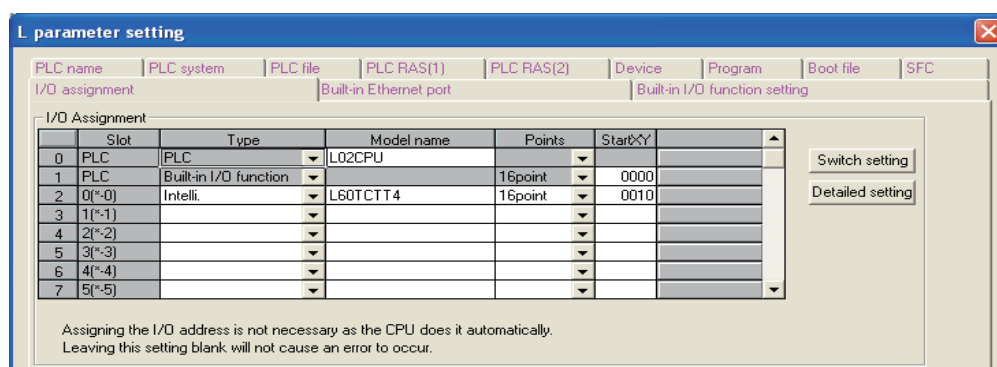

Item	Description
Type	Select "Intelli."
Model name	Enter the model name of the module.
Points	Select 16point.
Start XY	Enter an arbitrary start I/O number of the L60TC4.

Remark

Select 16point in Points when using the L60TCTT4BW or L60TCRT4BW.

A

(2) Intelligent function module switch setting

Configure the setting on "Switch Setting" in "PLC parameter".

Parameter ⇨ [PLC parameter] ⇨ [I/O assignment] ⇨ Click **Switch setting**.

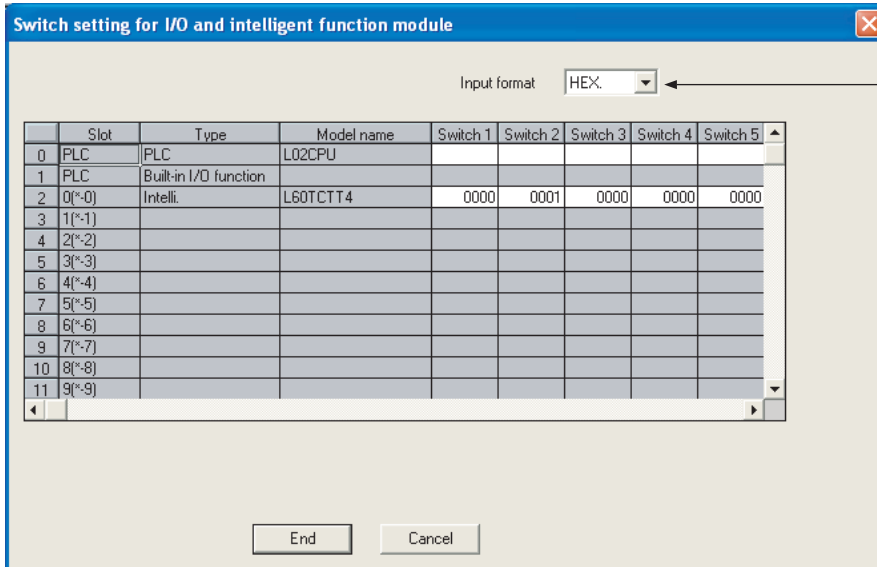

Select "HEX.".

Item	Setting item		
Switch 1	 CH4 CH3 CH2 CH1 H	Control output HOLD/CLEAR setting	
		Setting value	Output setting
		0	CLEAR
		Other than 0	HOLD
Switch 2	Setting value ^{*2}	Mode selection ^{*1}	
		Control mode	Number of control loops
	0000 _H	Standard control	Standard control 4 loops
	0001 _H	Heating-cooling control (normal mode)	Heating-cooling control 2 loops
	0002 _H	Heating-cooling control (expanded mode) ^{*3}	Heating-cooling control 4 loops
	0003 _H	Mix control (normal mode)	Heating-cooling control 1 loop Standard control 2 loops
	0004 _H	Mix control (expanded mode) ^{*3}	Heating-cooling control 2 loops Standard control 2 loops
0100 _H	Temperature input mode	—	

Item	Setting item
Switch 3	<p style="text-align: center;">Function extension bit specification, sampling cycle selection</p> <div style="text-align: center;"> <p>b15 b14 b13 b12 b11 b10 b9 b8 b7 b6 b5 b4 b3 b2 b1 b0</p> </div>
	<p>Switch 4 0: Fixed (empty)</p> <p>Switch 5 0: Fixed (empty)</p>

- *1 Immediately after the setting is changed, a set value discrepancy error (error code: 0□□E_H) occurs. To clear the set value discrepancy error, turn off, on, and off Set value backup instruction (Yn8).
- *2 When the setting is out of the setting value, a switch setting error (error code: 000F_H) occurs. In this case, the module does not operate properly. Set the correct value.
- *3 Control in the expanded mode requires an external output module. For details, refer to Page 127, Section 8.2.1 (3).

A

Appendix 5.2 Initial setting and auto refresh setting

The initial setting and auto refresh setting cannot be configured when GX Developer is used. Use the program instead.

(1) Initial setting

Configure the initial setting using the program. (☞ Page 250, CHAPTER 10)

(2) Auto refresh setting

To access the buffer memory using the program, perform one of the following methods.

(a) Access using FROM/TO instruction

Use FROM instruction to store the data read from the buffer memory in the L60TC4 into the specified device.

Use TO instruction to write the data of the specified device to the buffer memory in the L60TC4.

For details on FROM/TO instruction, refer to the following.

📖 MELSEC-Q/L Programming Manual (Common Instructions)

(b) Access using Intelligent function module device

Use Intelligent function module device (Un\G□) to access the buffer memory in the L60TC4.

Ex. When Error code (Un\G0) is transferred to D0 in the CPU module.

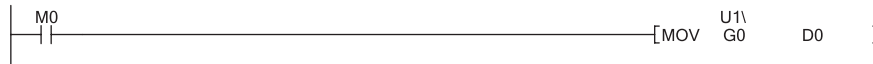

Appendix 6 External Dimensions

The following shows the external dimensions of the L60TC4.

(1) L60TCTT4

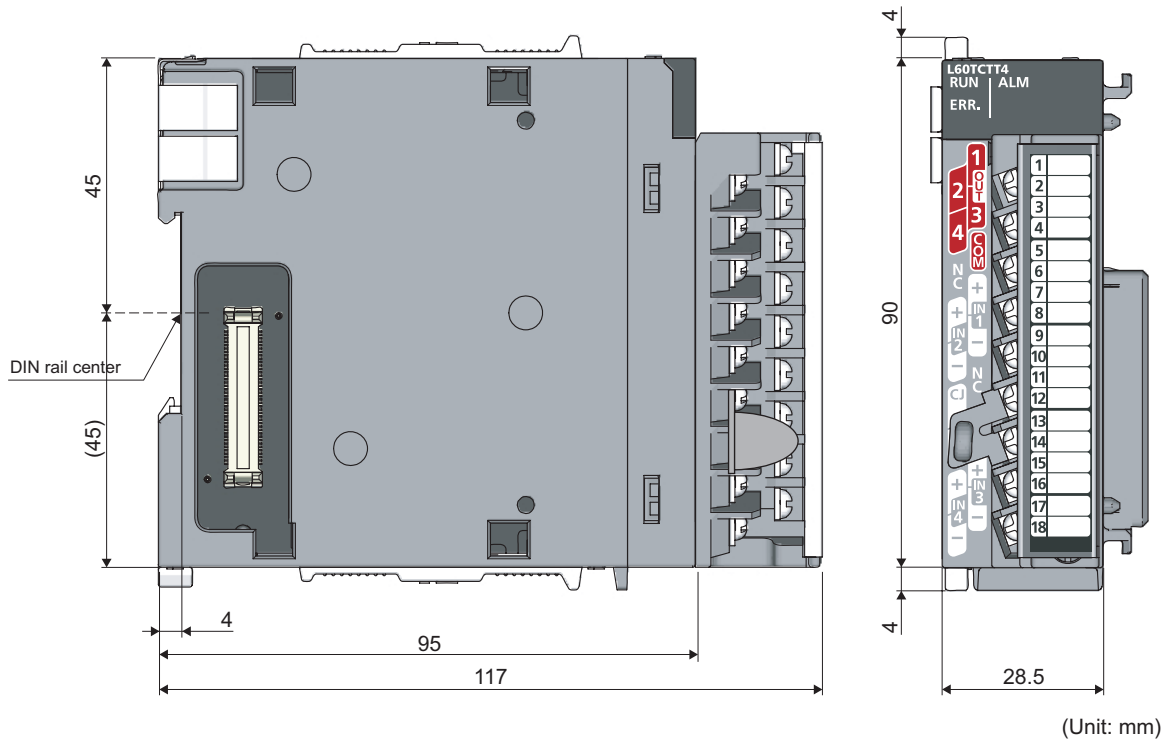

(2) L60TCTT4BW

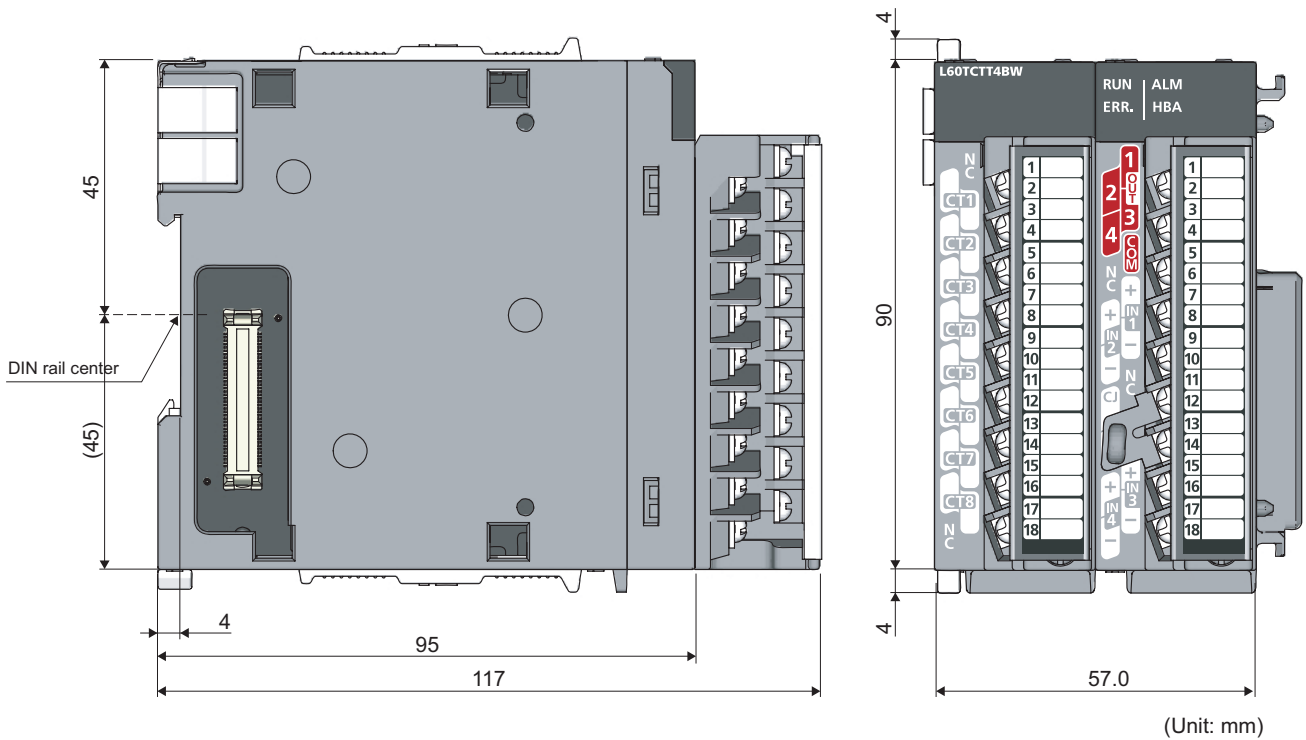

A

Appendix 6 External Dimensions

(3) L60TCRT4

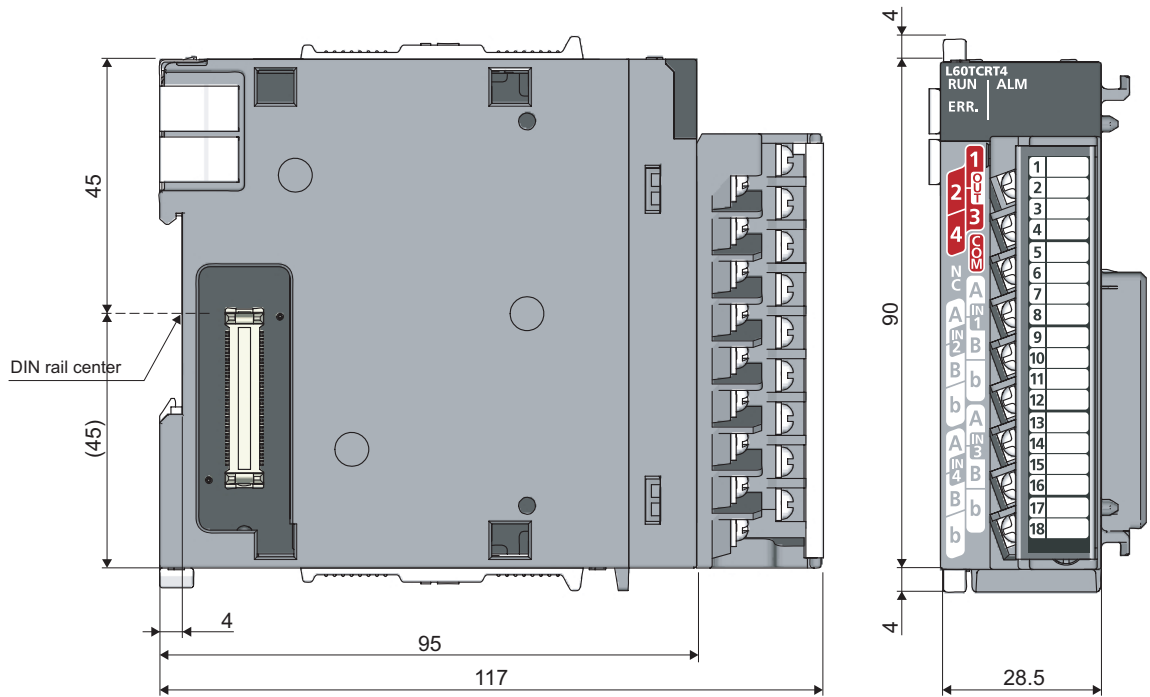

(Unit: mm)

(4) L60TCRT4BW

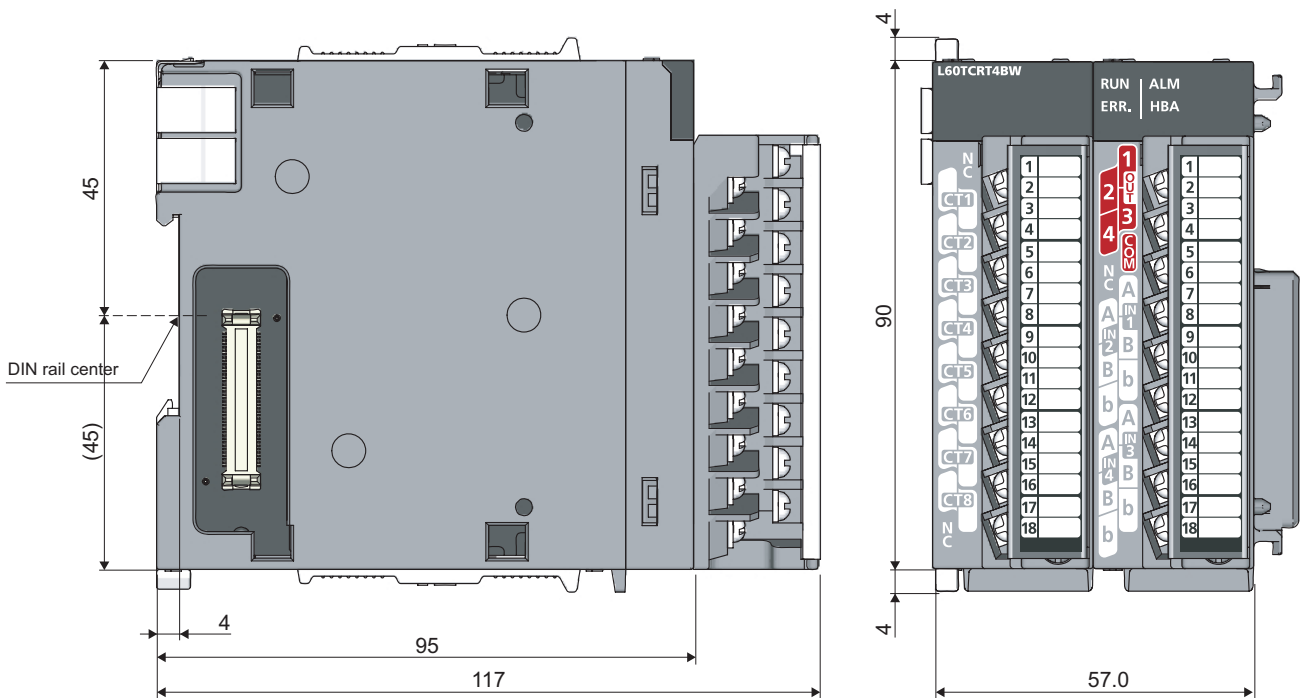

(Unit: mm)

Memo

A

Appendix 6 External Dimensions

INDEX

0 to 9

- 1-point sensor compensation (standard) 223,413
- 2-point sensor compensation. 413
- 2-point sensor compensation function 227

A

- Accuracy 32
- Added functions 417
- Adjustment after auto tuning 152
- Air cooled 207
- Air cooling 404
- Alarm code list 318
- Alarm priorities 320
- Alert 157
- Alert dead band 168
- Alert dead band setting (Un\G164) 379
- Alert mode and settings 170
- Alert mode and the set value (SV) to be referred . . 162
- Alert output 120
- Alert with standby 163
- Alert with standby (second time) 164
- Algorithm of PID control in process-value incomplete derivation 23
- ALM LED 29,311
- Applicable software version 82
- Applicable solderless terminal 33
- Applicable systems 82
- Applicable wire size 33
- AT point 370
- AT simultaneous temperature rise parameter calculation completion 398
- AT simultaneous temperature rise parameter calculation error status 398
- Auto configuration at input range change 234
- Auto refresh 114
- Auto tuning 141
- Automatic setting when the input range is change 414
- Auto-setting at input range change . . 108,109,351,352

B

- Backup of the calculated value on completion of auto tuning 143
- Back-up of the set value completion flag (Xn8) . . . 327
- Back-up of the set value fail flag (XnA) 313,328
- Batch/individual setting for temperature rise and temperature drop 155
- Buffer memory 14
- Buffer memory address by mode 44
- Buffer memory address for error history 76
- Buffer memory areas related to auto tuning 142
- Buffer memory areas related to control method . . . 135
- Buffer memory areas which can be set only in the setting mode 330
- Buffer memory data backup 235
- Buffer memory list 44

C

- Checking the completion of auto tuning 151
- Checking the error 248
- CH□ 2-point sensor compensation gain latch completion (Un\G551, Un\G583, Un\G615, Un\G647) 397
- CH□ 2-point sensor compensation gain latch request (Un\G550, Un\G582, Un\G614, Un\G646) 397
- CH□ 2-point sensor compensation gain value (compensation value) (Un\G547, Un\G579, Un\G611, Un\G643) 395
- CH□ 2-point sensor compensation gain value (measured value) (Un\G546, Un\G578, Un\G610, Un\G642) 395
- CH□ 2-point sensor compensation offset latch completion (Un\G549, Un\G581, Un\G613, Un\G645) 396
- CH□ 2-point sensor compensation offset latch request (Un\G548, Un\G580, Un\G612, Un\G644) 396
- CH□ 2-point sensor compensation offset value (compensation value) (Un\G545, Un\G577, Un\G609, Un\G641) 394
- CH□ 2-point sensor compensation offset value (measured value) (Un\G544, Un\G576, Un\G608, Un\G640) 394
- CH□ Adjustment sensitivity (dead band) setting (Un\G46, Un\G78, Un\G110, Un\G142) 129,130,363
- CH□ Alert 1 mode setting (Un\G192, Un\G208, Un\G224, Un\G240) 386
- CH□ Alert 2 mode setting (Un\G193, Un\G209, Un\G225, Un\G241) 386
- CH□ Alert 3 mode setting (Un\G194, Un\G210, Un\G226, Un\G242) 386
- CH□ Alert 4 mode setting (Un\G195, Un\G211, Un\G227, Un\G243) 386
- CH□ Alert definition (Un\G5 to Un\G8) 336
- CH□ Alert occurrence flag (XnC to XnF) 313,329
- CH□ Alert set value 1 (Un\G38, Un\G70, Un\G102, Un\G134) 358
- CH□ Alert set value 2 (Un\G39, Un\G71, Un\G103, Un\G135) 358
- CH□ Alert set value 3 (Un\G40, Un\G72, Un\G104, Un\G136) 358
- CH□ Alert set value 4 (Un\G41, Un\G73, Un\G105, Un\G137) 358
- CH□ AT bias setting (Un\G53, Un\G85, Un\G117, Un\G149) 370
- CH□ AT simultaneous temperature rise parameter calculation flag (Un\G573, Un\G605, Un\G637, Un\G669) 398
- CH□ Auto tuning instruction (Yn4 to Yn7) 331
- CH□ Auto tuning mode selection (Un\G184 to Un\G187) 385,409
- CH□ Auto tuning status (Xn4 to Xn7) . . . 312,313,326
- CH□ AUTO/MAN mode shift (Un\G50, Un\G82, Un\G114, Un\G146) 367,368
- CH□ Automatic backup setting after auto tuning of PID constants (Un\G63, Un\G95, Un\G127, Un\G159) 378

CH□ Control output cycle setting (Un\G47, Un\G79, Un\G111, Un\G143)	364
CH□ Control response parameter (Un\G49, Un\G81, Un\G113, Un\G145)	366
CH□ Cooling control output cycle setting (Un\G722, Un\G738, Un\G754, Un\G770)	364
CH□ Cooling proportional band (Pc) setting (Un\G720, Un\G736, Un\G752, Un\G768)	355
CH□ Cooling transistor output flag (Un\G712 to Un\G715)	341
CH□ Cooling upper limit output limiter (Un\G721, Un\G737, Un\G753, Un\G769)	360
CH□ Decimal point position (Un\G1 to Un\G4)	334
CH□ Derivative action selection (Un\G729, Un\G745, Un\G761, Un\G777)	407
CH□ Derivative time (D) setting (Un\G37, Un\G69, Un\G101, Un\G133)	357
CH□ Forward/reverse action setting (Un\G54, Un\G86, Un\G118, Un\G150)	371
CH□ Heater disconnection alert setting (Un\G58, Un\G90, Un\G122, Un\G154)	373
CH□ Heating control output cycle setting (Un\G47, Un\G79, Un\G111, Un\G143)	364
CH□ Heating proportional band (Ph) setting (Un\G35, Un\G67, Un\G99, Un\G131)	355
CH□ Heating transistor output flag (Un\G21 to Un\G24)	341
CH□ Heating upper limit output limiter (Un\G42, Un\G74, Un\G106, Un\G138)	360
CH□ Input range (Un\G32, Un\G64, Un\G96, Un\G128)	345
CH□ Integral time (I) setting (Un\G36, Un\G68, Un\G100, Un\G132)	357
CH□ Loop disconnection detection dead band (Un\G60, Un\G92, Un\G124, Un\G156)	375
CH□ Loop disconnection detection judgment time (Un\G59, Un\G91, Un\G123, Un\G155)	374
CH□ Lower limit output limiter (Un\G43, Un\G75, Un\G107, Un\G139)	360
CH□ Lower limit setting limiter (Un\G56, Un\G88, Un\G120, Un\G152)	372
CH□ MAN output setting (Un\G51, Un\G83, Un\G115, Un\G147)	368
CH□ Manipulated value (MV) (Un\G13 to Un\G16)	339
CH□ Manipulated value (MV) for output with another analog module (Un\G177 to Un\G180)	383
CH□ Manipulated value for cooling (MVc) (Un\G704 to Un\G707)	339
CH□ Manipulated value for heating (MVh) (Un\G13 to Un\G16)	339
CH□ Manipulated value of cooling (MVc) for output with another analog module (Un\G708 to Un\G711)	383
CH□ Manipulated value of heating (MVh) for output with another analog module (Un\G177 to Un\G180)	383
CH□ Manual reset amount setting (Un\G724, Un\G740, Un\G756, Un\G772)	405
CH□ Memory of PID constants read instruction (Un\G62, Un\G94, Un\G126, Un\G158)	343,377
CH□ Output variation limiter setting (Un\G44, Un\G76, Un\G108, Un\G140)	362
CH□ Overlap/dead band function (Un\G723, Un\G739, Un\G755, Un\G771)	404

CH□ PID control forced stop instruction (YnC to YnF)	333
CH□ Primary delay digital filter setting (Un\G48, Un\G80, Un\G112, Un\G144)	365
CH□ Process alarm alert output enable/disable setting (Un\G196, Un\G212, Un\G228, Un\G244)	387
CH□ Process alarm lower lower limit value (Un\G197, Un\G213, Un\G229, Un\G245)	388
CH□ Process alarm lower upper limit value (Un\G198, Un\G214, Un\G230, Un\G246)	388
CH□ Process alarm upper lower limit value (Un\G199, Un\G215, Un\G231, Un\G247)	388
CH□ Process alarm upper upper limit value (Un\G200, Un\G216, Un\G232, Un\G248)	388
CH□ Process value (PV) scaling function enable/disable setting (Un\G725, Un\G741, Un\G757, Un\G773)	405
CH□ Process value (PV) scaling lower limit value (Un\G726, Un\G742, Un\G758, Un\G774)	406
CH□ Process value (PV) scaling upper limit value (Un\G727, Un\G743, Un\G759, Un\G775)	406
CH□ Process value (PV) scaling value (Un\G728, Un\G744, Un\G760, Un\G776)	406
CH□ Proportional band (P) setting (Un\G35, Un\G67, Un\G99, Un\G131)	355
CH□ Rate alarm alert detection cycle (Un\G202, Un\G218, Un\G234, Un\G250)	389
CH□ Rate alarm alert output enable/disable setting (Un\G201, Un\G217, Un\G233, Un\G249)	389
CH□ Rate alarm lower limit value (Un\G204, Un\G220, Un\G236, Un\G252)	390
CH□ Rate alarm upper limit value (Un\G203, Un\G219, Un\G235, Un\G251)	390
CH□ Self-tuning flag (Un\G575, Un\G607, Un\G639, Un\G671)	400
CH□ Self-tuning setting (Un\G574, Un\G606, Un\G638, Un\G670)	399
CH□ Sensor correction value setting (Un\G45, Un\G77, Un\G109, Un\G141)	363
CH□ Set value (SV) monitor (Un\G25 to Un\G28)	158,342
CH□ Set value (SV) setting (Un\G34, Un\G66, Un\G98, Un\G130)	158,354
CH□ Setting change rate limiter (temperature drop) (Un\G564, Un\G596, Un\G628, Un\G660)	369
CH□ Setting change rate limiter (temperature rise) (Un\G52, Un\G84, Un\G116, Un\G148)	369
CH□ Setting change rate limiter (Un\G52, Un\G84, Un\G116, Un\G148)	369
CH□ Setting change rate limiter time unit setting (Un\G735, Un\G751, Un\G767, Un\G783)	342,411
CH□ Simultaneous temperature rise AT mode selection (Un\G733, Un\G749, Un\G765, Un\G781)	409
CH□ Simultaneous temperature rise dead time (Un\G732, Un\G748, Un\G764, Un\G780)	408
CH□ Simultaneous temperature rise gradient data (Un\G731, Un\G747, Un\G763, Un\G779)	408
CH□ Simultaneous temperature rise group setting (Un\G730, Un\G746, Un\G762, Un\G778)	407
CH□ Simultaneous temperature rise status (Un\G734, Un\G750, Un\G766, Un\G782)	410
CH□ Stop mode setting (Un\G33, Un\G65, Un\G97, Un\G129)	353
CH□ Temperature conversion setting (Un\G695 to Un\G697)	403

CH□ Temperature process value (PV) (Un\G9 to Un\G12)	338
CH□ Temperature process value (PV) for input with another analog module(Un\G689 to Un\G692) . . .	402
CH□ Temperature rise judgment flag (Un\G17 to Un\G20)	340
CH□ Transistor output flag (Un\G21 to Un\G24) . .	341
CH□ Unused channel setting (Un\G61, Un\G93, Un\G125, Un\G157)	376
CH□ Upper limit output limiter (Un\G42, Un\G74, Un\G106, Un\G138)	360,412
CH□ Upper limit setting limiter (Un\G55, Un\G87, Un\G119, Un\G151)	372
Clearing error	249
Cold junction temperature compensation accuracy: (ambient temperature: 0 to 55°C)	32
Cold junction temperature compensation resistor	30,87
Cold junction temperature compensation selection (Un\G182)	384
Cold junction temperature process value (Un\G29)	342
Compensation lead wire	93,94,95,96,97,98
Condition for alert judgment	166
Condition where CH□ Alert occurrence flag (XnC to XnF) turns off	166
Conditions for self-tuning (starting ST)	178
Conditions for self-tuning (vibration ST)	180
Conditions for the simultaneous temperature rise function	193
Conditions where auto tuning cannot be executed	149
Conditions where auto tuning ends in fail	150
Conditions where self-tuning does not complete due to errors	183
Conditions where self-tuning is not executed	181
Connection terminal	33
Control method	14,129
Control mode	14,126
Control mode selection	109
Control output	32
Control output cycle	32,38,140
Control output cycle unit selection	140
Control output cycle unit selection setting	109,414
Control output setting at CPU stop error	128
Control switching monitor (Un\G183)	385
Conversion enable/disable	117
Conversion enable/disable setting (Un\G693)	402
Cooling method setting	207
Cooling method setting (Un\G719)	404
CPU module	14,81
CT monitor method switching (Un\G176)	382
CT ratio setting	393
CTL-12-S36-10 (0.0 to 100.0A)	82
CTL-12-S36-8 (0.0 to 100.0A)	82
CTL-12-S56-10 (0.0 to 100.0A)	82
CTL-6-P (0.00 to 20.00A)	82
CTL-6-P-H (0.00 to 20.00A)	82
CT□ CT input channel assignment setting (Un\G264 to Un\G271)	390,391
CT□ CT ratio setting (Un\G288 to Un\G295)	392,393
CT□ CT selection (Un\G272 to Un\G279)	392
CT□ Heater current process value (Un\G256 to Un\G263)	390

CT□ Reference heater current value (Un\G280 to Un\G287)	390,393
Current sensor for heater disconnection detection . .	82

D

Data read from non-volatile memory	236
Data write to non-volatile memory	235
Dead band	210
Dead band setting range	32
Default setting registration instruction (Yn9)	332,376
Default value write completion flag (Xn9)	327
Derivative action (D-action)	27
Derivative action selection	154
Deviation alert	158
Dielectric withstand voltage	33
Differences	417
Differences between auto tuning and self-tuning . .	175
DIN rail hook	30
Discontinuation of self-tuning	182
Display unit	14,241
Displayed in English	243

E

Effect from wiring resistance of 1 ohm	36
ERR. LED	29,310
Error clear	240
Error code	321
Error code (Un\G0)	334
Error code list	315
Error code priorities	317
Error history	237
Error history 1 to 16 (Un\G1280 to Un\G1407) . . .	415
Error occurrence flag (Xn2)	312,325
Error reset instruction (Yn2)	331
Expanded mode	127
External dimensions	423
External output	14

F

Fixed value action	14,407
Forward action	24,203
Full scale	14
Function extension bit monitor (Un\G787)	414
Function list	39
Function version	321,416
Functional comparison	417

G

GX Developer	14,419
GX Works2	14

H

H/W LED information	322
H/W switch information	322
Hardware error flag (Xn3)	312,325
HBA LED	29
Head module	14,81
Heater disconnection correction function	217

Heater disconnection correction function selection (Un\G170)	381
Heater disconnection detection	215
Heater disconnection detection specifications	33
Heater disconnection detection wiring and setting example for three-phase heater	105
Heater disconnection/output off-time current error detection delay count(Un\G166)	380
Heating-cooling control	126
Heating-cooling control (expanded mode)	126,127
Heating-cooling control (normal mode)	126
High response mode	385
How to check error history	237
How to execute 2-point sensor compensation (when using GX Works2)	228
How to execute 2-point sensor compensation (when using the program)	232

I

Indication accuracy	32
Initial setting change screen	242
Input alert	157
Input filter	32
Input impedance	32
Input range	345
Input signal	323
Input signal list	42
Input/output (with another analog module)	172
Installation of the terminal block	91
Insulation method	32
Insulation resistance	33
Integral action (I-action)	26
Internal current consumption	33

L

L60TC4	14
L60TC4 actions	24
L60TC4 as a temperature control module	109
L60TCRT4	14,424
L60TCRT4BW	14,424
L60TCTT4	14,423
L60TCTT4BW	14,423
Latest address of error history (Un\G1279)	415
LED	310
Linear	207,404
Loop disconnection detection	204
Loops	126
Lower limit deviation alert	160

M

MAN mode shift completion flag (Un\G30)	342,368
Manipulated value (MV) and control output cycle	339
Manual control	139,361,362
Manual reset	129,137
MELSEC-Q series	417
Memory of PID constants read/write completion flag (Un\G31)	343
Mix control (expanded mode)	126,127
Mix control (normal mode)	126
Mode shifting	324
Module error history	239

Module joint levers	29
Module READY flag (Xn0)	312,323
Module selection	107
Module's detailed information	321
Monitoring the scaling value	221
Mount position	107

N

New module	107
Number of accesses to non-volatile memory	32
Number of alert delay	169
Number of alert delay (Un\G165)	379
Number of connectable modules	82
Number of loops	14
Number of occupied I/O points	33
Number of parameters	34
Number of temperature input points	32

O

Offset	25
Offset (remaining deviation)	132,137
ON delay output	174
ON delay output flag	174,341,382
ON/OFF timing for CH□ Automatic backup setting after auto tuning of PID constants (Un\G63, Un\G95, Un\G127, Un\G159)	344
Operation at sensor input disconnection	32
Operation method and formula	23
Operation mode (in operation)	324
Operation of the simultaneous temperature rise function	191
Operation on completion of auto tuning	151
Operation with starting ST	178
Operation with vibration ST	180
Outline dimensions	33
Output off-time current error detection	220
Output Setting at CPU Stop Error	128
Output setting at CPU stop error	109
Output signal	330
Output signal list	43
Overlap	209

P

P control	131,137,357
Package	15
Parameter setting	110
Part names	29
PD control	133,137
Peak current suppression	185
Peak current suppression control group setting (Un\G784)	193,412
Performance specifications	32
PI control	132,357
PID action	28
PID auto-correction status	400
PID constant range	32
PID constants	14
PID continuation flag (Un\G169)	128,381
PID control	133
Platinum resistance thermometer type	350
Primary delay digital filter	118

Procedure before operation	79
Procedure for the self-tuning control	177
Procedure of auto tuning	144
Process alarm	120
Processing of the error history function	237
Product information	321
Program compatibility	418
Programming procedure	250
Programming tool	14
Proportional action	356
Proportional action (P-action)	25
Proportional band setting	206
Proportional gain	25,356

Q

Q64TCRTBWN	417
Q64TCRTN	417
Q64TCTTBWN	417
Q64TCTTN	417

R

R1.25-3.	85
Ramp action	14,407
Rate alarm	122
Removal and installation of the terminal block	91
Resolution	36,345,351
Resolution of the manipulated value for output with another analog module(Un\G181)	384
Reverse action	24,203
RFB limiter function	171
RUN LED	29,310

S

Sampling cycle	32,38,106,117
Sampling cycle monitor (Un\G788)	414
Sampling cycle selection	108,109
Self-tuning	175
Self-tuning disable status	400
Self-tuning error	401
Sensor compensation function selection (Un\G785)	413
Sensor correction value setting	32
Serial number plate	30
Serial number	416
Set value (SV) and the setting change rate limiter setting	158
Set value (SV) setting range	32
Set value backup instruction (Yn8)	332
Setting change completion flag (XnB)	328
Setting change instruction (YnB)	332
Setting change rate limiter setting	109,155,414
Setting manipulated value (MV) in MAN mode	342
Setting mode (after operation)	324
Setting mode at power-ON	324
Setting value change screen list	243
Setting/operation mode instruction (Yn1)	328,330
Setting/operation mode status (Xn1)	324
Signal names of terminal blocks	86
Simple two-degree-of-freedom	22,153
Simultaneous temperature rise	190
Simultaneous temperature rise AT	194

Simultaneous temperature rise AT disable status	398
Simultaneous temperature rise parameter	193,399,401
Simultaneous temperature rise parameter correction status	400
Simultaneous temperature rise parameter error status	401
Solderless terminal	85
Standard control	126
Standard mode	385
Starting ST	399
Switch setting	108
System configuration	81

T

Temperature	117
Temperature control method	32
Temperature control mode	13,14,125
Temperature control modules	417
Temperature conversion	212
Temperature conversion completion flag (Un\G786)	413
Temperature conversion method	117
Temperature input mode	13,14,116
Temperature judgment	337
Temperature measurement range	36,336
Temperature process value (PV) scaling	221
Temperature rise completion range setting (Un\G167)	340,380
Temperature rise completion soak time setting (Un\G168)	340,381
Temperature sensor	14,345
Temperature unit	345
Terminal	30
Terminal block	85
Terminal block for CT	30,90
Terminal block for I/O	30,86,88
Terminal block mounting screw	85
Terminal screw	85
Terms	14
The condition to be able to perform PID control	134
The simultaneous temperature rise parameter setting using self-tuning	197
Thermocouple type	346
Thermocouple wiring resistance value	314
Three-phase heater	105
Three-position control	211
Tightening torque range	85
Time constant	118
Title setting	107
To clear the disconnection detection status	219
To forcibly start up self-tuning	184
Transistor output	32
Transistor output monitor ON delay time setting (Un\G175)	341,382
Troubleshooting	308
Troubleshooting by symptom	314
Two-position control	129,355,361,362
Type of usable temperature sensors	36

U

Unused channel	327
Unused channel setting	106
Upper limit deviation alert.	159
Upper lower limit deviation alert	160

V

Vibration ST	399
------------------------	-----

W

Watchdog timer error.	323
Water cooled	207
Water cooling	404
Weight.	33
When AUTO mode is shifted to MAN mode	367
When measured value exceeds temperature measurement range	338
When measured value falls below temperature measurement range	338
When the auto tuning does not complete	313
When the auto tuning does not start	312
When the self-tuning does not start	313
When the temperature process value (PV) is abnormal	314
When using the L60TC4 as a temperature input module	108
Wire	85
Wiring	92,93
Within-range alert	161



REVISIONS

*The manual number is given on the bottom left of the back cover.

Print date	*Manual number	Revision
July, 2011	SH(NA)-081000ENG-A	First edition

Japanese manual version SH-080999-A

This manual confers no industrial property rights or any rights of any other kind, nor does it confer any patent licenses. Mitsubishi Electric Corporation cannot be held responsible for any problems involving industrial property rights which may occur as a result of using the contents noted in this manual.

© 2011 MITSUBISHI ELECTRIC CORPORATION

WARRANTY

Please confirm the following product warranty details before using this product.

1. Gratis Warranty Term and Gratis Warranty Range

If any faults or defects (hereinafter "Failure") found to be the responsibility of Mitsubishi occurs during use of the product within the gratis warranty term, the product shall be repaired at no cost via the sales representative or Mitsubishi Service Company.

However, if repairs are required onsite at domestic or overseas location, expenses to send an engineer will be solely at the customer's discretion. Mitsubishi shall not be held responsible for any re-commissioning, maintenance, or testing on-site that involves replacement of the failed module.

[Gratis Warranty Term]

The gratis warranty term of the product shall be for one year after the date of purchase or delivery to a designated place.

Note that after manufacture and shipment from Mitsubishi, the maximum distribution period shall be six (6) months, and the longest gratis warranty term after manufacturing shall be eighteen (18) months. The gratis warranty term of repair parts shall not exceed the gratis warranty term before repairs.

[Gratis Warranty Range]

- (1) The range shall be limited to normal use within the usage state, usage methods and usage environment, etc., which follow the conditions and precautions, etc., given in the instruction manual, user's manual and caution labels on the product.
- (2) Even within the gratis warranty term, repairs shall be charged for in the following cases.
 1. Failure occurring from inappropriate storage or handling, carelessness or negligence by the user. Failure caused by the user's hardware or software design.
 2. Failure caused by unapproved modifications, etc., to the product by the user.
 3. When the Mitsubishi product is assembled into a user's device, Failure that could have been avoided if functions or structures, judged as necessary in the legal safety measures the user's device is subject to or as necessary by industry standards, had been provided.
 4. Failure that could have been avoided if consumable parts (battery, backlight, fuse, etc.) designated in the instruction manual had been correctly serviced or replaced.
 5. Failure caused by external irresistible forces such as fires or abnormal voltages, and Failure caused by force majeure such as earthquakes, lightning, wind and water damage.
 6. Failure caused by reasons unpredictable by scientific technology standards at time of shipment from Mitsubishi.
 7. Any other failure found not to be the responsibility of Mitsubishi or that admitted not to be so by the user.

2. Onerous repair term after discontinuation of production

- (1) Mitsubishi shall accept onerous product repairs for seven (7) years after production of the product is discontinued.
Discontinuation of production shall be notified with Mitsubishi Technical Bulletins, etc.
- (2) Product supply (including repair parts) is not available after production is discontinued.

3. Overseas service

Overseas, repairs shall be accepted by Mitsubishi's local overseas FA Center. Note that the repair conditions at each FA Center may differ.

4. Exclusion of loss in opportunity and secondary loss from warranty liability

Regardless of the gratis warranty term, Mitsubishi shall not be liable for compensation of damages caused by any cause found not to be the responsibility of Mitsubishi, loss in opportunity, lost profits incurred to the user by Failures of Mitsubishi products, special damages and secondary damages whether foreseeable or not, compensation for accidents, and compensation for damages to products other than Mitsubishi products, replacement by the user, maintenance of on-site equipment, start-up test run and other tasks.

5. Changes in product specifications

The specifications given in the catalogs, manuals or technical documents are subject to change without prior notice.

Microsoft, Windows, Windows NT, and Windows Vista are registered trademarks of Microsoft Corporation in the United States and other countries.

Pentium is a trademark of Intel Corporation in the United States and other countries.

Ethernet is a trademark of Xerox Corporation.

The SD logo and SDHC logo are trademarks.

All other company names and product names used in this manual are trademarks or registered trademarks of their respective companies.



MELSEC-L Temperature Control Module User's Manual

MODEL	L60TCTT4/RT4-U-E
MODEL CODE	13JZ64
SH(NA)-081000ENG-A(1107)MEE	



HEAD OFFICE : TOKYO BUILDING, 2-7-3 MARUNOUCHI, CHIYODA-KU, TOKYO 100-8310, JAPAN
NAGOYA WORKS : 1-14, YADA-MINAMI 5-CHOME, HIGASHI-KU, NAGOYA, JAPAN

When exported from Japan, this manual does not require application to the
Ministry of Economy, Trade and Industry for service transaction permission.

Specifications subject to change without notice.

HEADQUARTERS

MITSUBISHI ELECTRIC EUROPE B.V. **EUROPE**
 German Branch
 Gothaer Straße 8
D-40880 Ratingen
 Phone: +49 (0)2102 / 486-0
 Fax: +49 (0)2102 / 486-1120

MITSUBISHI ELECTRIC EUROPE B.V.-org.sl. **CZECH REP.**
 Czech Branch
 Avenir Business Park, Radlická 714/113a
CZ-158 00 Praha 5
 Phone: +420 - 251 551 470
 Fax: +420 - 251-551-471

MITSUBISHI ELECTRIC EUROPE B.V. **FRANCE**
 French Branch
 25, Boulevard des Bouvets
F-92741 Nanterre Cedex
 Phone: +33 (0)1 / 55 68 55 68
 Fax: +33 (0)1 / 55 68 57 57

MITSUBISHI ELECTRIC EUROPE B.V. **IRELAND**
 Irish Branch
 Westgate Business Park, Ballymount
IRL-Dublin 24
 Phone: +353 (0)1 4198800
 Fax: +353 (0)1 4198890

MITSUBISHI ELECTRIC EUROPE B.V. **ITALY**
 Italian Branch
 Viale Colleoni 7
I-20041 Agrate Brianza (MB)
 Phone: +39 039 / 60 53 1
 Fax: +39 039 / 60 53 312

MITSUBISHI ELECTRIC EUROPE B.V. **POLAND**
 Poland Branch
 Krakowska 50
PL-32-083 Balice
 Phone: +48 (0)12 / 630 47 00
 Fax: +48 (0)12 / 630 47 01

MITSUBISHI ELECTRIC EUROPE B.V. **RUSSIA**
 52, bid. 3 Kosmodamienskaya nab 8 floor
RU-115054 Moscow
 Phone: +7 495 721-2070
 Fax: +7 495 721-2071

MITSUBISHI ELECTRIC EUROPE B.V. **SPAIN**
 Spanish Branch
 Carretera de Rubí 76-80
E-08190 Sant Cugat del Vallés (Barcelona)
 Phone: 902 131121 // +34 935653131
 Fax: +34 935891579

MITSUBISHI ELECTRIC EUROPE B.V. **UK**
 UK Branch
 Travellers Lane
UK-Hatfield, Herts. AL10 8XB
 Phone: +44 (0)1707 / 27 61 00
 Fax: +44 (0)1707 / 27 86 95

MITSUBISHI ELECTRIC CORPORATION **JAPAN**
 Office Tower "Z" 14 F
 8-12,1 chome, Harumi Chuo-Ku
Tokyo 104-6212
 Phone: +81 3 622 160 60
 Fax: +81 3 622 160 75

MITSUBISHI ELECTRIC AUTOMATION, Inc. **USA**
 500 Corporate Woods Parkway
Vernon Hills, IL 60061
 Phone: +1 847 478 21 00
 Fax: +1 847 478 22 53

EUROPEAN REPRESENTATIVES

GEVA **AUSTRIA**
 Wiener Straße 89
AT-2500 Baden
 Phone: +43 (0)2252 / 85 55 20
 Fax: +43 (0)2252 / 488 60

TECHNIKON **BELARUS**
 Oktyabrskaya 19, Off. 705
BY-220030 Minsk
 Phone: +375 (0)17 / 210 46 26
 Fax: +375 (0)17 / 210 46 26

ESCO DRIVES & AUTOMATION **BELGIUM**
 Culliganlaan 3
BE-1831 Diegem
 Phone: +32 (0)2 / 717 64 30
 Fax: +32 (0)2 / 717 64 31

Koning & Hartman b.v. **BELGIUM**
 Woluwelaan 31
BE-1800 Vilvoorde
 Phone: +32 (0)2 / 257 02 40
 Fax: +32 (0)2 / 257 02 49

INEA RBT d.o.o. **BOSNIA AND HERZEGOVINA**
 Aleja Lipa 56
BA-71000 Sarajevo
 Phone: +387 (0)33 / 921 164
 Fax: +387 (0)33 / 524 539

AKHNATON **BULGARIA**
 4, Andrej Ljapchev Blvd., PO Box 21
BG-1756 Sofia
 Phone: +359 (0)2 / 817 6000
 Fax: +359 (0)2 / 97 44 06 1

INEA RBT d.o.o. **CROATIA**
 Losinjska 4 a
HR-10000 Zagreb
 Phone: +385 (0)1 / 36 940 -01 / -02 / -03
 Fax: +385 (0)1 / 36 940 -03

AutoCont C.S. s.r.o. **CZECH REPUBLIC**
 Technologická 374/6
CZ-708 00 Ostrava-Pustkovec
 Phone: +420 595 691 150
 Fax: +420 595 691 199

Beijer Electronics A/S **DENMARK**
 Lykkegårdsvej 17
DK-4000 Roskilde
 Phone: +45 (0)46 / 75 76 66
 Fax: +45 (0)46 / 75 56 26

Beijer Electronics Eesti OÜ **ESTONIA**
 Pärnu mnt.160i
EE-11317 Tallinn
 Phone: +372 (0)6 / 51 81 40
 Fax: +372 (0)6 / 51 81 49

Beijer Electronics OY **FINLAND**
 Peltoie 37
FIN-28400 Ulvila
 Phone: +358 (0)207 / 463 540
 Fax: +358 (0)207 / 463 541

UTEKO **GREECE**
 5, Mavrogenous Str.
GR-18542 Piraeus
 Phone: +30 211 / 1206 900
 Fax: +30 211 / 1206 999

MELTRADE Kft. **HUNGARY**
 Fertő utca 14.
HU-1107 Budapest
 Phone: +36 (0)1 / 431-9726
 Fax: +36 (0)1 / 431-9727

Beijer Electronics SIA **LATVIA**
 Rītausmas iela 23
LV-1058 Rīga
 Phone: +371 (0)784 / 2280
 Fax: +371 (0)784 / 2281

Beijer Electronics UAB **LITHUANIA**
 Savanoriu Pr. 187
LT-02300 Vilnius
 Phone: +370 (0)5 / 232 3101
 Fax: +370 (0)5 / 232 2980

EUROPEAN REPRESENTATIVES

ALFATRADE Ltd. **MALTA**
 99, Paola Hill
Malta- Paola PLA 1702
 Phone: +356 (0)21 / 697 816
 Fax: +356 (0)21 / 697 817

INTEHSIS srl **MOLDOVA**
 bld. Traian 23/1
MD-2060 Kishinev
 Phone: +373 (0)22 / 66 4242
 Fax: +373 (0)22 / 66 4280

HIFLEX AUTOM.TECHNIEK B.V. **NETHERLANDS**
 Wolweverstraat 22
NL-2984 CD Ridderkerk
 Phone: +31 (0)180 - 46 60 04
 Fax: +31 (0)180 - 44 23 55

Koning & Hartman b.v. **NETHERLANDS**
 Haarlerbergweg 21-23
NL-1101 CH Amsterdam
 Phone: +31 (0)20 / 587 76 00
 Fax: +31 (0)20 / 587 76 05

Beijer Electronics AS **NORWAY**
 Postboks 487
NO-3002 Drammen
 Phone: +47 (0)32 / 24 30 00
 Fax: +47 (0)32 / 84 85 77

Fonseca S.A. **PORTUGAL**
 R. João Francisco do Casal 87/89
PT - 3801-997 Aveiro, Esgueira
 Phone: +351 (0)234 / 303 900
 Fax: +351 (0)234 / 303 910

Sirius Trading & Services srl **ROMANIA**
 Aleea Lacul Morii Nr. 3
RO-060841 Bucuresti, Sector 6
 Phone: +40 (0)21 / 430 40 06
 Fax: +40 (0)21 / 430 40 02

INEA RBT d.o.o. **SERBIA**
 Izletnicka 10
SER-113000 Smederevo
 Phone: +381 (0)26 / 615 401
 Fax: +381 (0)26 / 615 401

SIMAP s.r.o. **SLOVAKIA**
 Jána Derku 1671
SK-911 01 Trenčín
 Phone: +421 (0)32 743 04 72
 Fax: +421 (0)32 743 75 20

PROCONT, spol. s r.o. **SLOVAKIA**
 Prešov
 Kúpeľná 1/A
SK-080 01 Prešov
 Phone: +421 (0)51 7580 611
 Fax: +421 (0)51 7580 650

INEA RBT d.o.o. **SLOVENIA**
 Stegne 11
SI-1000 Ljubljana
 Phone: +386 (0)1 / 513 8116
 Fax: +386 (0)1 / 513 8170

Beijer Electronics AB **SWEDEN**
 Box 426
SE-20124 Malmö
 Phone: +46 (0)40 / 35 86 00
 Fax: +46 (0)40 / 93 23 01

Omni Ray AG **SWITZERLAND**
 Im Schörl 5
CH-8600 Dübendorf
 Phone: +41 (0)44 / 802 28 80
 Fax: +41 (0)44 / 802 28 28

GTS **TURKEY**
 Bayraktar Bulvarı Nutuk Sok. No:5
TR-34775 Yukarı Dudullu-Ümraniye-İSTANBUL
 Phone: +90 (0)216 526 39 90
 Fax: +90 (0)216 526 3995

CSC Automation Ltd. **UKRAINE**
 4-B, M. Raskovoyi St.
UA-02660 Kiev
 Phone: +380 (0)44 / 494 33 55
 Fax: +380 (0)44 / 494-33-66

Systemgroup **UKRAINE**
 2 M. Krivonosy St.
UA-03680 Kiev
 Phone: +380 (0)44 / 490 92 29
 Fax: +380 (0)44 / 248 88 68

EURASIAN REPRESENTATIVES

TOO Kazpromavtomatika **KAZAKHSTAN**
 Ul. Zhambyla 28
KAZ-100017 Karaganda
 Phone: +7 7212 / 50 10 00
 Fax: +7 7212 / 50 11 50

MIDDLE EAST REPRESENTATIVES

ILAN & GAVISH Ltd. **ISRAEL**
 24 Shenkar St., Kiryat Arie
IL-49001 Petah-Tiqva
 Phone: +972 (0)3 / 922 18 24
 Fax: +972 (0)3 / 924 0761

GIRIT CELADON LTD **ISRAEL**
 12 H'aomanut Street
IL-42505 Netanya
 Phone: +972 (0)9 / 863 39 80
 Fax: +972 (0)9 / 885 24 30

CEG INTERNATIONAL **LEBANON**
 Cebaco Center/Block A Autostrade DORA
Lebanon - Beirut
 Phone: +961 (0)1 / 240 430
 Fax: +961 (0)1 / 240 438

AFRICAN REPRESENTATIVE

CBI Ltd. **SOUTH AFRICA**
 Private Bag 2016
ZA-1600 Isando
 Phone: + 27 (0)11 / 977 0770
 Fax: + 27 (0)11 / 977 0761