

mitsubishi









Mitsubishi Industrial Robot

RV-3SB/3SJB Series

Standard Specifications Manual
(CR1B-571/CR2B-574 Controller)

Safety Precautions

Always read the following precautions and the separate "Safety Manual" before starting use of the robot to learn the required measures to be taken.

-  **CAUTION** All teaching work must be carried out by an operator who has received special training. (This also applies to maintenance work with the power source turned ON.)
Enforcement of safety training
-  **CAUTION** For teaching work, prepare a work plan related to the methods and procedures of operating the robot, and to the measures to be taken when an error occurs or when restarting. Carry out work following this plan. (This also applies to maintenance work with the power source turned ON.)
Preparation of work plan
-  **WARNING** Prepare a device that allows operation to be stopped immediately during teaching work. (This also applies to maintenance work with the power source turned ON.)
Setting of emergency stop switch
-  **CAUTION** During teaching work, place a sign indicating that teaching work is in progress on the start switch, etc. (This also applies to maintenance work with the power source turned ON.)
Indication of teaching work in progress
-  **WARNING** Provide a fence or enclosure during operation to prevent contact of the operator and robot.
Installation of safety fence
-  **CAUTION** Establish a set signaling method to the related operators for starting work, and follow this method.
Signaling of operation start
-  **CAUTION** As a principle turn the power OFF during maintenance work. Place a sign indicating that maintenance work is in progress on the start switch, etc.
Indication of maintenance work in progress
-  **CAUTION** Before starting work, inspect the robot, emergency stop switch and other related devices, etc., and confirm that there are no errors.
Inspection before starting work

The points of the precautions given in the separate "Safety Manual" are given below. Refer to the actual "Safety Manual" for details.

- ⚠ CAUTION** Use the robot within the environment given in the specifications. Failure to do so could lead to a drop or reliability or faults. (Temperature, humidity, atmosphere, noise environment, etc.)
- ⚠ CAUTION** Transport the robot with the designated transportation posture. Transporting the robot in a non-designated posture could lead to personal injuries or faults from dropping.
- ⚠ CAUTION** Always use the robot installed on a secure table. Use in an instable posture could lead to positional deviation and vibration.
- ⚠ CAUTION** Wire the cable as far away from noise sources as possible. If placed near a noise source, positional deviation or malfunction could occur.
- ⚠ CAUTION** Do not apply excessive force on the connector or excessively bend the cable. Failure to observe this could lead to contact defects or wire breakage.
- ⚠ CAUTION** Make sure that the workpiece weight, including the hand, does not exceed the rated load or tolerable torque. Exceeding these values could lead to alarms or faults.
- ⚠ WARNING** Securely install the hand and tool, and securely grasp the workpiece. Failure to observe this could lead to personal injuries or damage if the object comes off or flies off during operation.
- ⚠ WARNING** Securely ground the robot and controller. Failure to observe this could lead to malfunctioning by noise or to electric shock accidents.
- ⚠ CAUTION** Indicate the operation state during robot operation. Failure to indicate the state could lead to operators approaching the robot or to incorrect operation.
- ⚠ WARNING** When carrying out teaching work in the robot's movement range, always secure the priority right for the robot control. Failure to observe this could lead to personal injuries or damage if the robot is started with external commands.
- ⚠ CAUTION** Keep the jog speed as low as possible, and always watch the robot. Failure to do so could lead to interference with the workpiece or peripheral devices.
- ⚠ CAUTION** After editing the program, always confirm the operation with step operation before starting automatic operation. Failure to do so could lead to interference with peripheral devices because of programming mistakes, etc.
- ⚠ CAUTION** Make sure that if the safety fence entrance door is opened during automatic operation, the door is locked or that the robot will automatically stop. Failure to do so could lead to personal injuries.
- ⚠ CAUTION** Never carry out modifications based on personal judgments, or use non-designated maintenance parts.
Failure to observe this could lead to faults or failures.
- ⚠ WARNING** When the robot arm has to be moved by hand from an external area, do not place hands or fingers in the openings. Failure to observe this could lead to hands or fingers catching depending on the posture.

⚠ CAUTION

Do not stop the robot or apply emergency stop by turning the robot controller's main power OFF. If the robot controller main power is turned OFF during automatic operation, the robot accuracy could be adversely affected. Moreover, it may interfere with the peripheral device by drop or move by inertia of the arm.

⚠ CAUTION

Do not turn off the main power to the robot controller while rewriting the internal information of the robot controller such as the program or parameters.
If the main power to the robot controller is turned off while in automatic operation or rewriting the program or parameters, the internal information of the robot controller may be damaged.

Precautions for the basic configuration are shown below. (When CR1-571/CR1B-571 is used for the controller.)

⚠ CAUTION

Provide an earth leakage breaker that packed together on the primary power supply of the controller as protection against electric leakage. Confirm the setting connector of the input power supply voltage of the controller, if the type which more than one power supply voltage can be used. Then connect the power supply.
Failure to do so could lead to electric shock accidents.

Power supply *RV-1A/2AJ series and RP-1AH/3AH/5AH series: Single phase 90-132VAC, 180-253VAC.
*Except the above: Single phase 180-253VAC.

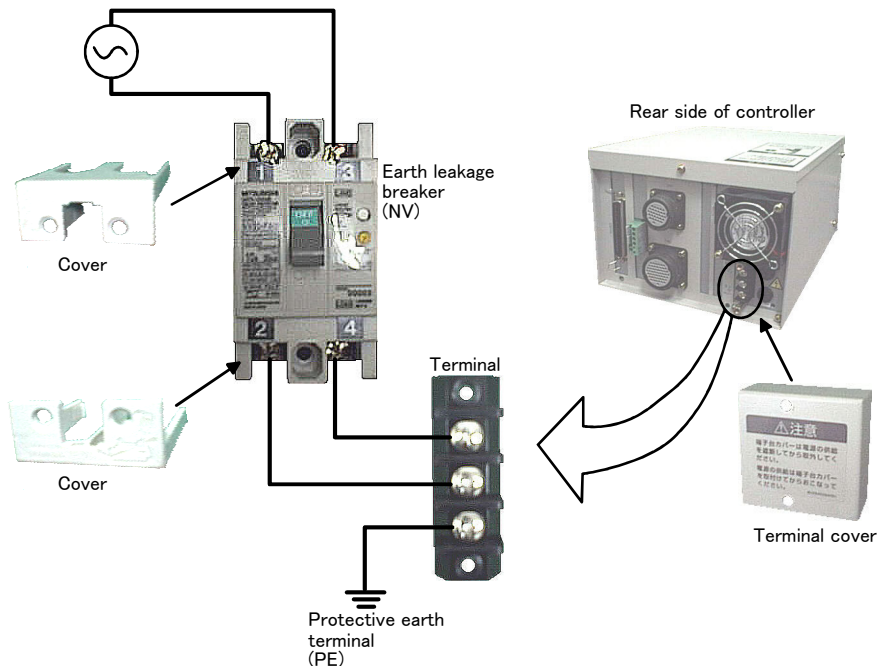

■ Revision history

Date of print	Specifications No.	Details of revisions
2005-04-26	BFP-A8408	First print.

■ Introduction

This series provides compact vertical multi-joint robots for use in machine processes and assemblies. This series is especially designed to answer the needs of users who want to create compact and highly flexible production facilities to cope with shortened product life cycles as well as the diffusion of small and high density product groups in recent years, such as personal computer related devices, information terminal devices and small car-mounted electronic devices. This series supports the oil mist environment as standard, offering variations of 5-axis type, 6-axis type and clean specification.

However, to comply with the target application, a work system having a well-balanced robot arm, peripheral devices or robot and hand section must be structured.

When creating these standard specifications, we have edited them so that the Mitsubishi robot's characteristics and specifications can be easily understood by users considering the implementation of robots. However, if there are any unclear points, please contact your nearest Mitsubishi branch or dealer.

Mitsubishi hopes that you will consider these standard specifications and use our robots.

Note that in this specification document the specifications related to the robot arm is described "[2 Robot arm](#)" on [page 9](#) , the specifications related to the controller "[3 Controller](#)" on [page 40](#) , and software functions and a command list "[4 Software](#)" on [page 100](#) separately.

The contents of this manual correspond to the following robot types.

- | | |
|--------|------------|
| <Type> | • RV-3SB |
| | • RV-3SBC |
| | • RV-3SJB |
| | • RV-3SJBC |

- No part of this manual may be reproduced by any means or in any form, without prior consent from Mitsubishi.
- The contents of this manual are subject to change without notice.
- The specifications values are based on Mitsubishi standard testing methods.
- The information contained in this document has been written to be accurate as much as possible. Please interpret that items not described in this document "cannot be performed.". Please contact your nearest dealer if you find any doubtful, wrong or skipped point.
- Microsoft, Windows, Microsoft Windows NT are either registered trademarks or trademarks of Microsoft Corporation in the United States and/or other countries.

Contents

Page

1 General configuration	1-1
1.1 Structural equipment	1-1
1.1.1 Standard structural equipment	1-1
1.1.2 Shipping special specifications	1-1
1.1.3 Options	1-1
1.1.4 Maintenance parts	1-1
1.2 Model type combination of robot	1-2
1.2.1 Combinations of robot arms and controllers	1-2
1.2.2 How to identify the robot model	1-2
1.3 CE marking specifications	1-3
1.4 Indirect export	1-3
1.5 Instruction manuals	1-3
1.6 Contents of the structural equipment	1-4
1.6.1 Robot arm	1-4
1.7 Controller	1-5
1.7.1 CR1B-571 controller	1-5
1.7.2 CR2B-574 controller	1-6
1.8 Contents of the Option equipment and special specification	1-7
2 Robot arm	2-9
2.1 Standard specifications	2-9
2.2 Definition of specifications	2-10
2.2.1 Pose repeatability	2-10
2.2.2 Rated load (mass capacity)	2-11
2.2.3 Relationships Among Mass Capacity, Speed, and Acceleration/Deceleration Speed	2-12
(1) Setting Load Capacity and Size (Hand Conditions)	2-12
2.2.4 Vibrations at the Tip of the Arm during Low-Speed Operation of the Robot	2-12
2.2.5 Protection specifications and working environment	2-13
(1) Types of protection specifications	2-13
(2) About the use with the bad environment	2-14
2.2.6 Clean specifications	2-15
(1) Types of clean specifications	2-15
2.3 Names of each part of the robot	2-16
2.4 Outside dimensions * Operating range diagram	2-17
(1) RV-3SB/3SBC (6-axis type)	2-17
(2) RV-3SJB/3SJBC (5-axis type)	2-19
2.5 Tooling	2-21
2.5.1 Wiring and piping for hand	2-21
2.5.2 Internal air piping	2-22
(1) General-purpose environment/Oil mist specifications	2-22
(2) Clean type	2-22
2.5.3 Internal wiring for the pneumatic hand output cable	2-22
2.5.4 Internal wiring for the hand check input cable	2-22
2.5.5 Spare Wiring	2-22
2.5.6 Wiring and piping system diagram for hand	2-23
2.5.7 Electrical specifications of hand input/output	2-25
2.5.8 Air supply circuit example	2-26
2.6 Shipping special specifications, options, and maintenance parts	2-27
2.6.1 Shipping special specifications	2-27
(1) Machine cable	2-28
2.7 Options	2-29
(1) Machine cable extension	2-30
(2) Changing the operating range	2-33
(3) Solenoid valve set	2-34
(4) Hand input cable	2-36
(5) Hand output cable	2-37
(6) Hand curl tube	2-38
2.8 Maintenance parts	2-39

3 Controller	3-40
3.1 Standard specifications	3-40
3.1.1 Standard specifications	3-40
3.1.2 Protection specifications and operating supply	3-42
3.2 Names of each part	3-43
3.3 Outside dimensions/Installation dimensions	3-46
3.3.1 Outside dimensions	3-46
3.3.2 Installation dimensions	3-48
3.4 External input/output	3-49
3.4.1 Types	3-49
3.4.2 Explanation	3-49
3.5 Dedicated input/output	3-50
3.6 Emergency stop input/output	3-52
3.6.1 Connection of the external emergency stop	3-52
3.6.2 Door switch function	3-54
3.7 Parallel input/output unit	3-55
3.8 Options	3-60
(1) Teaching pendant (T/B)	3-61
(2) Pneumatic hand interface	3-64
(3) Controller protection box	3-67
(4) Expansion option box	3-70
(5) Parallel I/O unit	3-72
(6) External I/O cable	3-82
(7) Personal computer cable	3-84
(8) Extended serial interface	3-86
(9) CC-Link interface	3-88
(10) Ethernet interface	3-90
(11) Additional axis interface	3-92
(12) Extension memory cassette	3-94
(13) Personal computer support software/Personal computer support software mini	3-96
(14) Instruction Manual(bound edition)	3-98
3.9 Maintenance parts	3-99
4 Software	4-100
4.1 List of commands	4-100
(1) The procedure of robot language selection	4-100
(2) MELFA-BASIC IV commands	4-101
4.2 List of parameters	4-103
(1) List of parameters	4-103
(2) Change the display language / 表示言語の切り替え	4-105
5 Instruction Manual	5-106
5.1 The details of each instruction manuals	5-106
6 Safety	6-108
6.1 Safety	6-108
6.1.1 Self-diagnosis stop functions	6-108
6.1.2 External input/output signals that can be used for safety protection measures	6-108
6.1.3 Precautions for using robot	6-109
6.1.4 Safety measures for automatic operation	6-109
6.1.5 Safety measures for teaching	6-109
6.1.6 Safety measures for maintenance and inspections, etc.	6-109
6.1.7 Examples of safety measures	6-110
6.2 Working environment	6-112
6.3 Precautions for handling	6-113
7 Appendix	Appendix-114
Appendix 1 : Specifications discussion material	Appendix-114

1 General configuration

1.1 Structural equipment

Structural equipment consists of the following types.

1.1.1 Standard structural equipment

The following items are enclosed as a standard.

- (1) Robot arm
- (2) Controller
- (3) Machine cable
- (4) Robot arm installation bolts
- (5) Earth leakage breaker(CR1B-571 only)
- (6) Safety manual, CD-ROM (Instruction manual)
- (7) Guarantee card

1.1.2 Shipping special specifications

Part of the standard structural equipment is changed at the time of factory shipment. Consequently, kindly confirm the delivery date.

To make changes to the specifications after shipment, service work must be performed at the work site or the robot must be returned for service.

1.1.3 Options

Installation is possible after shipment. Customer needs to perform the installation work.

1.1.4 Maintenance parts

Consumable parts and spare parts for maintenance use.

For items not listed, contact the dealer where you made your purchase.

1.2 Model type combination of robot

The RV-3SB/3SJB series is different from the RV-3S/3SJ series in that the J4 and J6 axes of the robot arm are equipped with brakes. Since the product lineup includes robots with CE marking specification, there are specifications for combining it with a CR2B-574 controller. A list of model names that can be combined is shown below.

1.2.1 Combinations of robot arms and controllers

Table 1-1 : List of combinations of robot arms and controllers

Robot arm			Controller	
			CR1B-571	CR2B-574
6-axis type	Standard Specifications (oil mist)	RV-3SB	RV-3SB	RV-3SB-S300
	Clean Specifications	RV-3SBC	RV-3SBC	RV-3SBC-S300
5-axis type	Standard Specifications (oil mist)	RV-3SJB	RV-3SJB	RV-3SJB-S300
	Clean Specifications	RV-3SJBC	RV-3SJBC	RV-3SJBC-S300

1.2.2 How to identify the robot model

RV-3S **J** **B** **C** **-S300**
 (a) (b) (c) (d) (e)

(a). RV-3S.....Indicates the RV-3S series.

(b). J.....Indicates axis configuration.
 Examples)

Blank: 6-axis type.
 J: 5-axis type.

(c). BIndicates a specification with brakes for all axes.

(d). CIndicates environment specification.
 Examples)

Blank: Standard Specifications (IP65)
 C: Clean Specifications

(e). -S3 00.....[1] Indicates a special model number.
 (A) (B)

(A). -S3: Indicates that the special model number is between 300 and 599, which means the robot is connected to the CR2B-574 controller.

(B). 00: The least significant two digits of the special model number indicate a combination number of the external signal logic setting and the language setting at shipment. The combinations of the least significant two digits are shown below.

Table 1-2 : Reserved special numbers

External signal logic	Language setting (parameter: LNG) ^{Note1)}	
	Japanese (JPN)	English (ENG)
Sink type	00	11
Source type	_ ^{Note2)}	12

Note1) Robots are shipped with the language displayed on T/B set by the language setting parameter (LNG). (Settings can be changed by the customer.)

JPN: Japanese display

ENG: English display

Note2) There is no source type setting for the Japanese display.

[2] -SM**Indicates a specification with controller protection box. It is only applicable when you are using the CR1B-571 controller.

1.3 CE marking specifications

The RV-3S/3SJB series provides models with CE marking specifications as well,

Table 1-3 : Robot models with CE marking specifications

Robot type		Controller	External signal logic	Language setting (parameter: LNG)
6 axis-type	RV-3SB-S312	CR2B-574	Source type	English (ENG)
5 axis-type	RV-3SJB-S312			

Note) Please be aware that there are no robots with CE marking specifications that can be connected to the CR1B-571 controller.

1.4 Indirect export

If you intend to export robots bought from us, be sure to choose robots whose language setting parameter (LNG) is set to English (ENG).

1.5 Instruction manuals

The instruction manuals supplied with the shipment are provided in electronic form in a CD-ROM, except for the Safety Manual. This CD-ROM (electronic manual) includes instruction manuals in both Japanese and English versions. Please note that the instruction manuals are the same for both language settings (parameter LNG).

1.6 Contents of the structural equipment

1.6.1 Robot arm

The list of structural equipment is shown in Fig. 1-1.

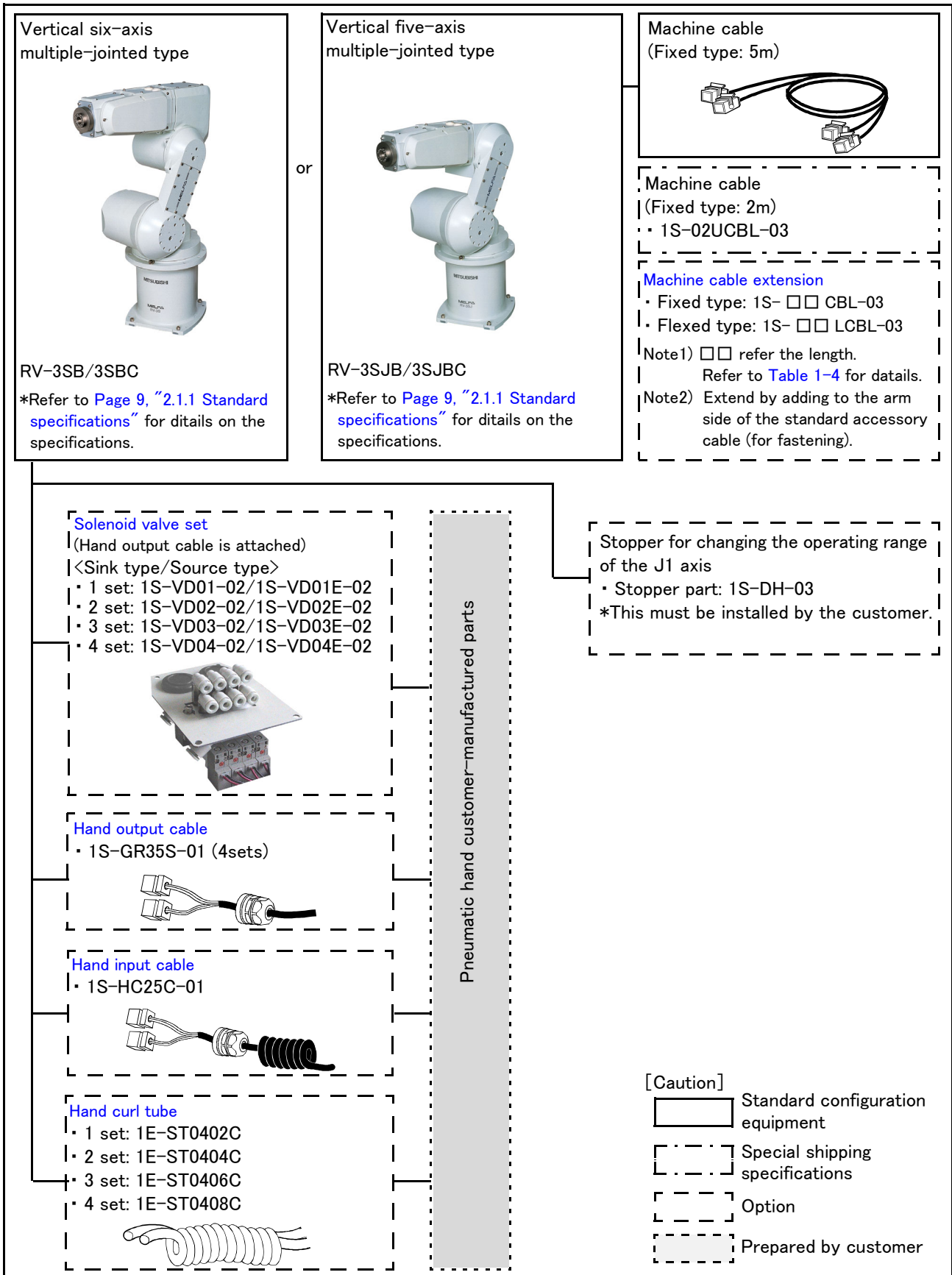

Fig.1-1 : Structural equipment (Robot arm)

1.7 Controller

The devices shown below can be installed on the controller.

The controllers that can be connected differ depending on the model of the robot arm. (Refer to Page 2, "1.2 Model type combination of robot")

1.7.1 CR1B-571 controller

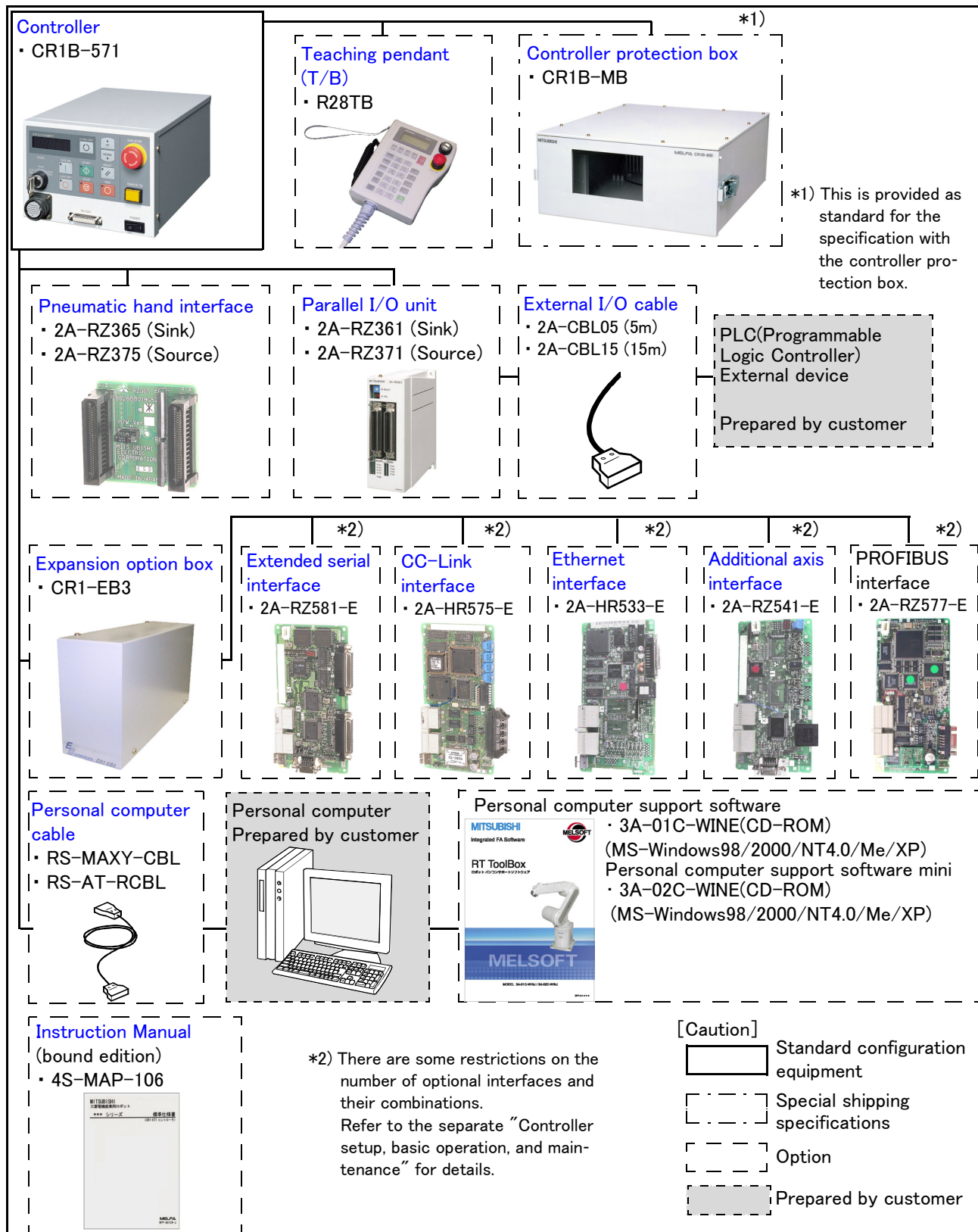

Fig.1-2 : Structural equipment(CR1B-571 controller)

1.7.2 CR2B-574 controller

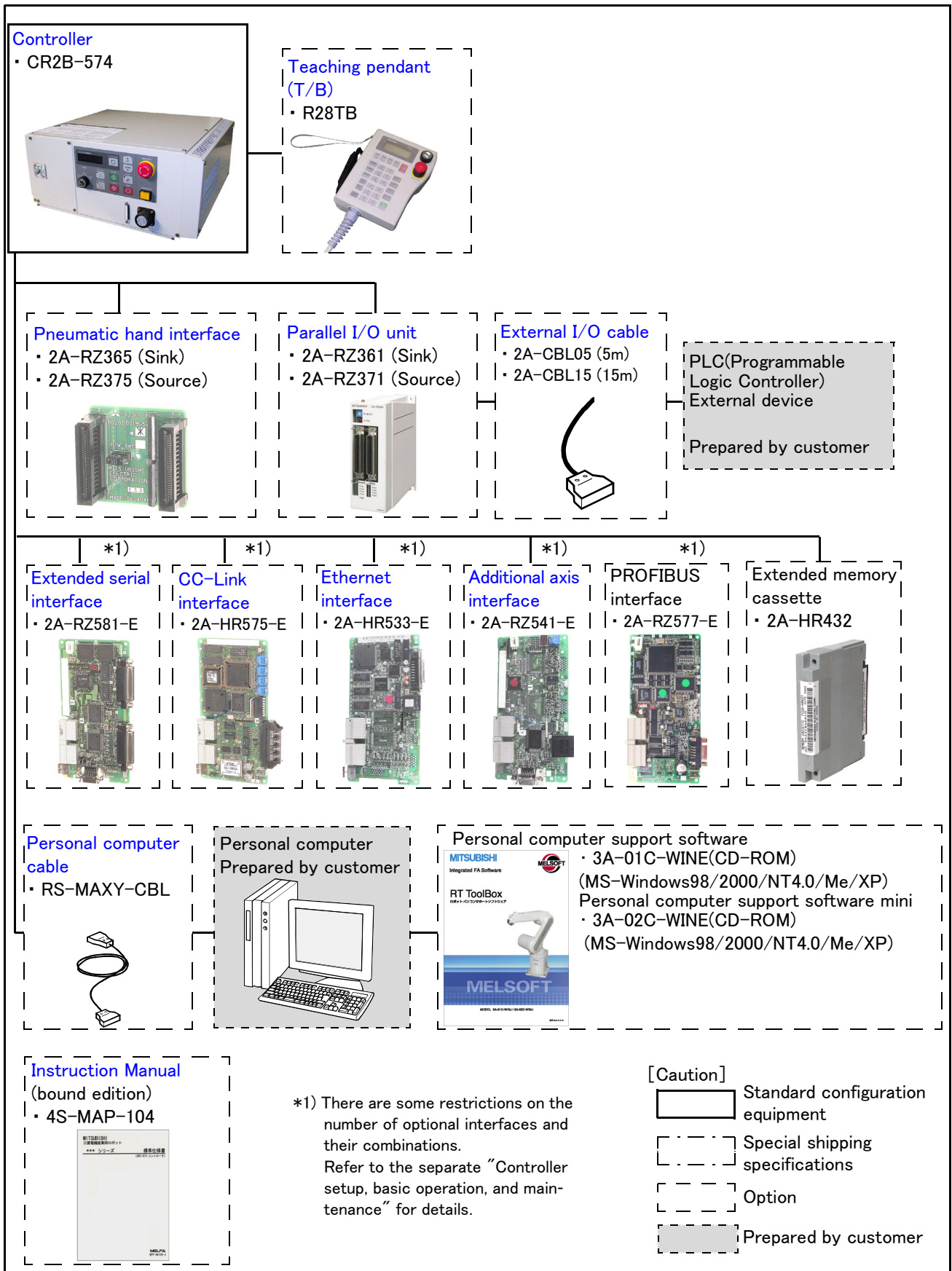

Fig.1-3 : Structural equipment(CR2B-574 controller)

1.8 Contents of the Option equipment and special specification

A list of all Optional equipments and special specifications are shown below.

Table 1-4 : The list of Option equipment and special specification

Item	Type	Specifications	Classification Note1)	Description
Stopper for changing the operating range of the J1 axis	1S-DH-03	Stopper part + side: +120, +90, +60, or +30 deg. - side: -120, -90, -60, or -30 deg. One each of the following can be selected: ± 170 deg. are used for the standard specification.	○	This must be installed by the customer.
Machine cable(Replaced with shorter cable)	1S-02UCBL-03	For fixing (Two sets for power and signal)	○ · □	2m(A 2 m cable is supplied instead of the 5 m cable that is supplied as standard)
Extended machine cable (Extension type)	1S- □ □ CBL-03	For fixing (Two sets for power and signal)	○	5, 10, 15m
	1S- □ □ LCBL-03	For bending (Two sets for power and signal)	○	5, 10, 15m
Solenoid valve set	1S-VD01-02	1 set (Sink type)	○	A solenoid valve set for the pneumatic hand
	1S-VD02-02	2 set (Sink type)	○	
	1S-VD03-02	3 set (Sink type)	○	
	1S-VD04-02	4 set (Sink type)	○	
	1S-VD01E-02	1 set (Source type)	○	
	1S-VD02E-02	2 set (Source type)	○	
	1S-VD03E-02	3 set (Source type)	○	
	1S-VD04E-02	4 set (Source type)	○	
Hand output cable	1S-GR35S-01	One terminal is not treated.	○	The cable is connected to the hand output connector by the customer.
Hand input cable	1S-HC25C-01		○	The cable is connected to the sensor by the customer.
Hand curl tube	1E-ST0402C	For solenoid valve 1set.: $\Phi 4 \times 2$	○	Curl type air tube
	1E-ST0404C	For solenoid valve 1set.: $\Phi 4 \times 4$	○	
	1E-ST0406C	For solenoid valve 1set.: $\Phi 4 \times 6$	○	
	1E-ST0407C	For solenoid valve 1set.: $\Phi 4 \times 8$	○	
Teaching pendant	R28TB	Cable length 7m	○	With 3-position deadman switch/ IP 65
	R28TB-15	Cable length 15m (special specification)	○	
Pneumatic hand interface	2A-RZ365	DO: 8 point (Sink type)	○	It is necessary when the hand output signal of the robot arm is used. (Integrated in the controller.)
	2A-RZ375	DO: 8 point (Source type)	○	
Parallel I/O interface	2A-RZ361	DO: 32 point (Sink type)/ DI : 32 point (Sink type)	○	The unit for expansion the external input/output. Electrical isolated Type (100mA/Point)
	2A-RZ371	DO: 32 point (Source type)/ DI : 32 point (Source type)	○	
External I/O cable	2A-CBL05	5m	○	Use to connect the external peripheral device to the parallel input/output unit
	2A-CBL15	15m	○	
Personal computer cable	RS-MAXY-CBL	RS-232C cable 3m for PC-AT compatible model	○	Use RS-AT-RCBL for the connection from the expansion option box.
	RS-AT-RCBL		○	
Personal computer Support software	3A-01C-WINE	CD-ROM	○	MS-Windows98/2000/NT4.0/Me/XP (With the simulation function)
Personal computer Support software mini	3A-02C-WINE	CD-ROM	○	MS-Windows98/2000/NT4.0/Me/XP
Expansion option box ^{Note2)}	CR1-EB3	Up to three option cards can be mounted	○	Install on the side of the controller
Extended serial interface ^{Note3)}	2A-RZ581-E	RS-232C x 1 RS-232C or RS-422 x 1	○	CR-EB3 is need.
CC-Link interface ^{Note3)}	2A-HR575-E	Local station (The local station alone is supported.)	○	for MELSEC PLC with CC-Link connection. CR-EB3 is need.
Ethernet interface ^{Note3)}	2A-HR533-E	ETHERNET x 1	○	CR-EB3 is need.
Additional axis interface ^{Note3)}	2A-RZ541-E	SSC x 1 Up to 8 axes can be added	○	MR-J2 servoAmplifier Unit connection. CR-EB3 is need.
PROFIBUS interface ^{Note3)}	2A-RZ577-E	PROFIBUS-DP slave	○	GSD file (FD) attached. CR-EB3 is need.
Extended memory cassette ^{Note4)}	2A-HR432	Teaching point number: 25,400 Steps number: 50,800 Program number: 100	○	The battery backup function is provided. Together with 2,500 points of standard teaching positions, the total number of teaching positions is 27,900 points.
Controller protection box ^{Note2) Note5)}	CR1B-MB	IP54	○ · □	The controller protection box is used to protect the controller from an oil mist or other operating environment. ^{Note2)}

Note1) In the classification column, ○ refers to an option, and □ to a Shipping special specifications.

Note2) This option only applies to the CR1B-571 controller.

Note3) CR1-EB3 is also required if you are using the CR1B-571 controller.

Note4) This option only applies to the CR2B-574 controller.

Note5) This is provided as standard for the specification with the controller protection box.

Table 1-3 : The list of Option equipment and special specification (Continued)

Item	Type	Specification	Classification Note1)	Description
Instruction Manual (CR1B-571 controller version)	4S-MAP-106	Instruction manual set for the CR1B-571 controller	○	
Safety Manual	BFP-A8006	Items relating to safety in handling the robot	○	
Standard Specifications	BFP-A8408	Specification of the robot arm and controller	○	
Robot Arm Setup & Maintenance	BFP-A8388	Installation method of the robot arm, jog operation, and maintenance and inspection procedures	○	
Controller Setup, Basic Operation and Maintenance	BFP-A8054	Installation method of the controller, basic operation, and maintenance and inspection procedures	○	
Detailed Explanation of Functions and Operations	BFP-A5992	Functions of the controller and T/B, operation method, and explanation of MELFA-BASIC IV	○	
Troubleshooting	BFP-A5993	Causes of errors occurred and their countermeasures	○	
Explanations of MOVEMASTER COMMANDS	BFP-A8056	Explains details of the MOVEMASTER commands	○	
Instruction Manual (CR2B-574 controller version)	4S-MAP-104	Instruction manual set for the CR2B-574 controller	○	
Safety Manual	BFP-A8006	Items relating to safety in handling the robot	○	
Standard Specifications	BFP-A8408	Specification of the robot arm and controller	○	
Robot Arm Setup & Maintenance	BFP-A8388	Installation method of the robot arm, jog operation, and maintenance and inspection procedures	○	
Controller Setup, Basic Operation and Maintenance	BFP-A5991	Installation method of the controller, basic operation, and maintenance and inspection procedures	○	
Detailed Explanation of Functions and Operations	BFP-A5992	Functions of the controller and T/B, operation method, and explanation of MELFA-BASIC IV	○	
Troubleshooting	BFP-A5993	Causes of errors occurred and their countermeasures	○	
Explanations of MOVEMASTER COMMANDS	BFP-A8056	Explains details of the MOVEMASTER commands	○	

Note1) In the classification column, ○ refers to an option, and □ to a Sipping special specifications.

2 Robot arm

2.1 Standard specifications

2.1.1 Standard specifications

Table 2-1 : Tab Standard specifications of robot

Item		Unit	Specifications			
Type			RV-3SB	RV-3SBC	RV-3SJB	RV-3SJBC
Type of robot			6-axis		5-axis	
	Environment		Standard (oil mist)	Clean	Standard (oil mist)	Clean
Degree of freedom			6		5	
Installation posture			On floor, hanging,(against wall ^{Note1)})			
Structure			Vertical, multiple-joint type			
Drive system			AC servo motor (with brakes for all axes)			
Position detection method			Absolute encoder			
Arm length	Upper arm	mm	245			
	Fore arm		270		300	
Operating range	Waist (J1) ^{Note1)}	Degree	340 (-170 to +170)			
	Shoulder (J2)		225 (-90 to +135)			
	Elbow (J3)		191 (-20 to +171)		237 (-100 to +137)	
	Wrist twist (J4)		320 (-160 to +160)		-	
	Wrist pitch (J5)		240 (-120 to +120)			
	Wrist roll (J6)		720 (-360 to +360)			
Speed of motion	Waist (J1)	Degree/s	250			
	Shoulder (J2)		187			
	Elbow (J3)		250			
	Wrist twist (J4)		412		-	
	Wrist pitch (J5)		412			
	Wrist roll (J6)		660			
Maximum resultant velocity ^{Note2)}		mm/sec	5,500		5,300	
Load	Maximum ^{Note3)}	kg	3.5			
	Rating		3			
Pose repeatability ^{Note4)}		mm	± 0.02			
Ambient temperature		°C	0 to 40			
Mass		kg	37		33	
Allowable moment load	Wrist twist (J4)	N · m	5.83		-	
	Wrist pitch (J5)		5.83			
	Wrist roll (J6)		3.9			
Allowable inertia	Wrist twist (J4)	kg · m ²	0.137		-	
	Wrist pitch (J5)		0.137			
	Wrist roll (J6)		0.047 ^{Note5)}			
Arm reachable radius front p-axis center point		mm	642		641	
Tool wiring ^{Note6)}			Hand input 8 point, hand output 8 point, eight spare wires (AWG#24(0.2mm ²) with shielded)			
Tool pneumatic pipes			Primary side: Φ6 × 2 (Base to fore arm section) Secondary side: Φ4 × 8 (Optional)			
Supply pressure		MPa	0.5 ± 10%			
Protection specification ^{Note7) Note8)}			IP65 (all axes)	-	IP65 (all axes)	-
Degree of cleanliness ^{Note9)}			-	10(0.3 μm) Internal suction requirement	-	10(0.3 μm) Internal suction requirement
Painting color			Light gray (Equivalent to Munsell: 0.08GY.64/0.81)			

Note1) When used by mounting on the wall, a special specification that limits the operating range of the J1 axis will be used. The operating range is limited by changing the mechanical stopper position and also by setting parameters.

Note2) This is the value on the hand flange surface when all axes are combined.

Note3) The maximum load capacity is the mass with the flange posture facing downward at the ± 10° limit.

Note4) The pose repeatability details are given in [Page 10, "2.2.1 Pose repeatability"](#)

Note5) When the optimum acceleration/deceleration mode is in effect, up to twice the specification value indicated here can be set.

Note6) The air hand interface (option) is required when the tool (hand) output is used.

Note7) The protection specification details are given in [Page 13, "2.2.5 Protection specifications and working environment"](#).

Note8) If you intend to use the controller in oil mist or similar environments, use the controller protection box (CR1B-MB) to protect the controller from the operation environment. A robot equipped with the controller protection box as standard is available("SM" is added to the model name.).

Note9) The clean specification details are given in [Page 15, "2.2.6 Clean specifications"](#). A down flow(0.3m/s or more) in the clean room is the necessary conditions for the cleanliness.

2.2 Definition of specifications

The accuracy of pose repeatability mentioned in catalogs and in the specification manual is defined as follows.

2.2.1 Pose repeatability

For this robot, the pose repeatability is given in accordance with JIS 8432 (Pose repeatability). Note that the value is based on 100 measurements (although 30 measurements are required according to JIS).

[Caution] The specified "pose repeatability" is not guaranteed to be satisfied under the following conditions.

- [1] Operation pattern factors
 - 1) When an operation that approaches from different directions and orientations are included in relation to the teaching position during repeated operations
 - 2) When the speed at teaching and the speed at execution are different
- [2] Load fluctuation factor
 - 1) When work is present/absent in repeated operations
- [3] Disturbance factor during operation
 - 1) Even if approaching from the same direction and orientation to the teaching position, when the power is turned OFF or a stop operation is performed halfway
- [4] Temperature factors
 - 1) When the operating environment temperature changes
 - 2) When accuracy is required before and after a warm-up operation
- [5] Factors due to differences in accuracy definition
 - 1) When accuracy is required between a position set by a numeric value in the robot's internal coordinate system and a position within the actual space
 - 2) When accuracy is required between a position generated by the pallet function ^{Note1)} and a position within the actual space

Note1)

The pallet function is a function that teaches only the position of the work used as reference (3 to 4 points) and obtains the remaining positions by calculations, for an operation that arranges works orderly or for an operation that unloads orderly arranged works. By using this function, for example, in the case of an operation that arranges works on grid points of 100 x 100, by teaching only three points of four corners, the remaining grid points are automatically generated; thus, it is not necessary to teach all 10,000 points. For more information about the pallet function, refer to the separate volume, "Instruction Manual/Detailed Explanation of Functions and Operations."

2.2.2 Rated load (mass capacity)

The robot's mass capacity is expressed solely in terms of mass, but even for tools and works of similar mass, eccentric loads will have some restrictions. When designing the tooling or when selecting a robot, consider the following issues.

- (1) The tooling should have the value less or equal than the smaller of the tolerable inertia and the tolerable moment found in Page 9, "Table 2-1 : Tab Standard specifications of robot"
- (2) Fig. 2-1 shows the distribution dimensions for the center of gravity in the case where the volume of the load is relatively small. Use this figure as a reference when designing the tooling.
- (3) When the load is not mass, but force, you should design the tooling so that it does not exceed the value for allowable moment described in Page 9, "Table 2-1 : Tab Standard specifications of robot"

[Caution] The mass capacity is greatly influenced by the operating speed of the robot and the motion posture. Even if you are within the allowable range mentioned previously, an overload or generate an overcurrent alarm could occur. In such cases, it will be necessary to change the time setting for acceleration/deceleration, the operating speed, and the motion posture.

[Caution] The overhang amount of the load for the specified moment and inertia in this section is the dynamic limit value determined by the motor driving each axis and by the capacity of the reduction gears. Consequently, accuracy cannot be guaranteed for the entire tooling area. Since accuracy is based on the center point of the mechanical interface surface, position accuracy can diminish as you go away from the flange surface, or vibration can result, with tooling that is not rigid or that is long.

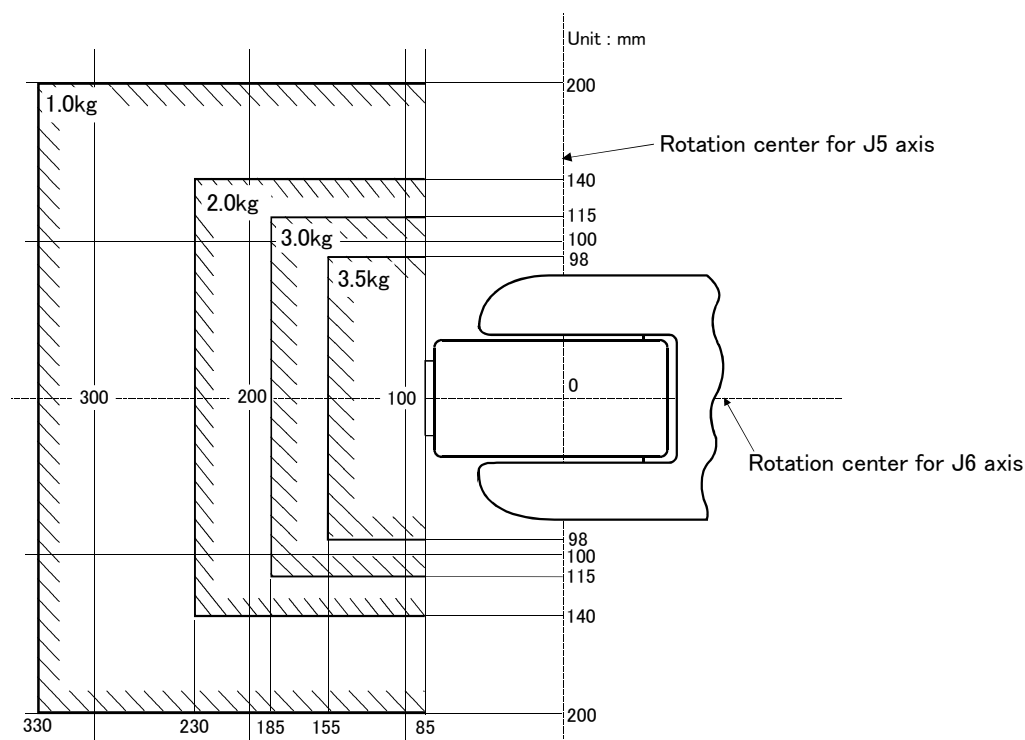

Fig.2-1 : Position of center of gravity for loads (for loads with comparatively small volume)

2.2.3 Relationships Among Mass Capacity, Speed, and Acceleration/Deceleration Speed

This robot automatically sets the optimum acceleration and deceleration speeds and maximum speed, according to the load capacity and size that have been set, and operates using these automatically set speeds.

To achieve that, it is necessary to correctly set the actual load data (mass and size of hand and work) to be used. However, vibration, overheating and errors such as excessive margin of error and overload may occur, depending on the robot operation pattern or ambient temperature. In such a case, change the setting value to the +20% range. If a setting is performed in such a way that it falls below the mounted load, the life span of the mechanism elements used in the robot may be shortened. In the case of a work requiring a high degree of accuracy, set up the load correctly and use the robot by lowering the ratios of the acceleration and deceleration speeds.

(1) Setting Load Capacity and Size (Hand Conditions)

Set up the capacity and size of the hand with the "HNDDAT*" parameter (optimum acceleration/deceleration setting parameter), and set up the capacity and size of the work with the "WRKDAT*" parameter. Numbers 0 to 8 can be used for the asterisk (*) part. Designate the "HNDDAT*" and "WRKDAT*" parameters to be used using the "LOADSET" command in a program.

For more details, refer to the separate "Instruction Manual/Detailed Explanation of Functions and Operations." It is the same meaning as "LOADSET 0.0" if not using the "LOADSET".

2.2.4 Vibrations at the Tip of the Arm during Low-Speed Operation of the Robot

Vibrations at the tip of the arm may increase substantially during the low-speed operation of the robot, depending on the combination of robot operation, hand mass and hand inertia. This problem occurs when the vibration count specific to the robot arm and the vibration count of the arm driving force are coming close to each other. These vibrations at the tip of the arm can be reduced by taking the following measures:

- 1) Lower the robot's operating speed by approximately 5% from high speed using the OVRD instruction.
- 2) Change and move the teaching points of the robot.
- 3) Change the hand mass and hand inertia.

2.2.5 Protection specifications and working environment

(1) Types of protection specifications

The robot arm has protection specifications that comply with the IEC Standards. The protection specifications and applicable fields are shown in [Table 2-2](#).

Table 2-2 : Protection specifications and applicable fields

Type	Protection specifications (IEC Standards value)	Classification	Applicable field	Remarks
RV-3SB RV-3SJB	Robot arm:IP65(all axes) Controller:IP20	General-purpose environment specifications and Oil mist specifications	General assembly Slightly dusty environment	Note that if the cutting machine contains abrasive materials, the machine line will be shortened.
RV-3SB-SM ^{Note1)} RV-3SJB-SM	Robot arm:IP65(all axes) Controller:IP54		Machine tool (cutting) Machine shop with heavy oil mist Dusty work shop	

Note1) The “-SM” specification (specification with the controller protection box) comes with the controller protection box (CR1B-MB) as standard.

CR1B-571 controller is required for the setting of the “-SM” specification.

CR2B-574 controller do not prepared “-SM” specification.

CAUTION

Use the controller protection box (CR1B-MB) optional to protect the controller from the environment when the CR1B-571 controller will be used in the environment such as the oil mist shown in the [Table 2-2](#). A robot equipped with the controller protection box as standard is available (Note 1 in [Table 2-2](#)). Refer to the section [Page 67, “\(3\) Controller protection box”](#) for details on the controller protection box.

The IEC IP symbols define the degree of protection against solids and fluids, and do not indicate a protective structure against the entry of oil or water.

The evaluation regarding oil mist specifications has been confirmed with Mitsubishi’s standard testing methods using the cutting oils shown in [Table 2-3](#).

Table 2-3 : Tested cutting oil for oil mist specifications

Name	Maker	Relevant JIS	Main characteristics	Application
Emulcut FA-800	Kyodo Yushi Co., Ltd	Equivalent to Class W1 No. 1	Water soluble cutting oil • Base oil50-60% • Surfactant and rust inhibitor30-40% • Additives.....5% or less • WaterThe rest	Water soluble cutting oil Emulcut

【Information】

- The IEC IP20

It indicates the protective structure that prevents an iron ball $12^{+0.05}_0$ mm diameter, which is being pressed with the power of $3.1 \text{ kg} \pm 10\%$, from going through the opening in the outer sheath of the supplied equipment.

- The IEC IP54

The IEC IP54 standard refers to protection structure designed to prevent any harmful effects by fresh water scattering vertically onto the testing equipment in a radius of 180 degrees from a distance of 300 to 500 mm, with 10 ± 0.5 liters of water every minute, at a water pressure of 80 to 100kPa, covering the entire area of the robot with the exception of the installation section at 1 m^2 per minute, for a total of 5 minutes or more.

- The IEC IP65

Protection against water infiltration as specified in IP65 indicates a protective structure that is not harmfully affected when $12.5 \pm 5\%$ liters of water is supplied from a test device at a position approx. 3m away in various directions and a water pressure of 30kPa at the nozzle section. The water is filled one minute per 1 m^2 of test device surface area for a total of three minutes.

(2) About the use with the bad environment

This robot has protection methods that conform to IEC's IP65(all axis) standards (splashproof type). It has protection structure designed to prevent harmful effects caused by splashing water coming from various directions, as the robot is operating. Recommended usage conditions.

- 1) The robot is designed for use in combination with machining device.
- 2) Please examine cutting oil referring to [Table 2-3](#) used by a standard examination of our company.
- 3) Take measures so that the robot will not be exposed to water, oil and/or chips for a long period of time.

The warranty is invalid for any faults that occur when the robot is used under the following conditions.

Also, if the cover and/or other parts are damaged by interferences caused by the peripheral devices and the robot, the protection specification (seal performance, etc.) may be degraded. Therefore, please pay extra attention when handling the robot.

Refer to [Page 112, "6.2 Working environment"](#).

- 1) In surroundings that generate inflammable gases or corrosive gasses.
- 2) Atmosphere used excluding cutting oil shown in [Table 2-3](#)
- 3) Environment where the robot is exposed to water, oil and/or chips for a long period of time.
- 4) In surroundings where chips fall directly on the robot. In surroundings where the minimum diameter of chips is less than 0.5mm.
- 5) Mist atmosphere exceeding the specification.

2.2.6 Clean specifications

(1) Types of clean specifications

The robot arm with clean specification is made by order. Please check the delivery schedule.

Table 2-4 : Clean specifications

Clean specifications	Type	Degree of cleanliness	Internal suction
RV-3SBC RV-3SJBC	10(0.3 μ m)	Concentrated suction with vacuum generating valve.	The use of a vacuum generating valve is recommended.

Table 2-5 : Specifications of vacuum generation valve

Type	Maker	Air pressure
MEDT 14	KONEGAI CORPORATION	0.2 to 0.6 MPa

■ Precautions for use

- 1) When using a device that moves or rotates the robot arm, the down flow may not be secured because of the air flow. In this case, the degree of cleanliness cannot be ensured.
- 2) A $\Phi 8$ coupling is provided in the base section of the robot arm for suction inside the robot arm. When using the robot, connect this coupling with the vacuum generating valve and vacuum pump (furnished by the customer).
 - * Install the vacuum generating valve downstream of the downflow or install a filter in the exhaust air section so that the exhaust air from the vacuum generating valve does not affect cleanliness.
Recommended filter: Exhaust filter EF300-02, Koganei Corporation
 - * If any vacuum pump is prepared by the customer, assure on the vacuum side flow rate 30 liters/min.(ANR) or more .
- 3) When using the Mitsubishi standard option solenoid valve set, use the spare piping ($\Phi 6$ pneumatic hose) of the primary piping to exhaust the air.
If the exhaust leaks into the robot arm, the degree of cleanliness could be affected.

2.3 Names of each part of the robot

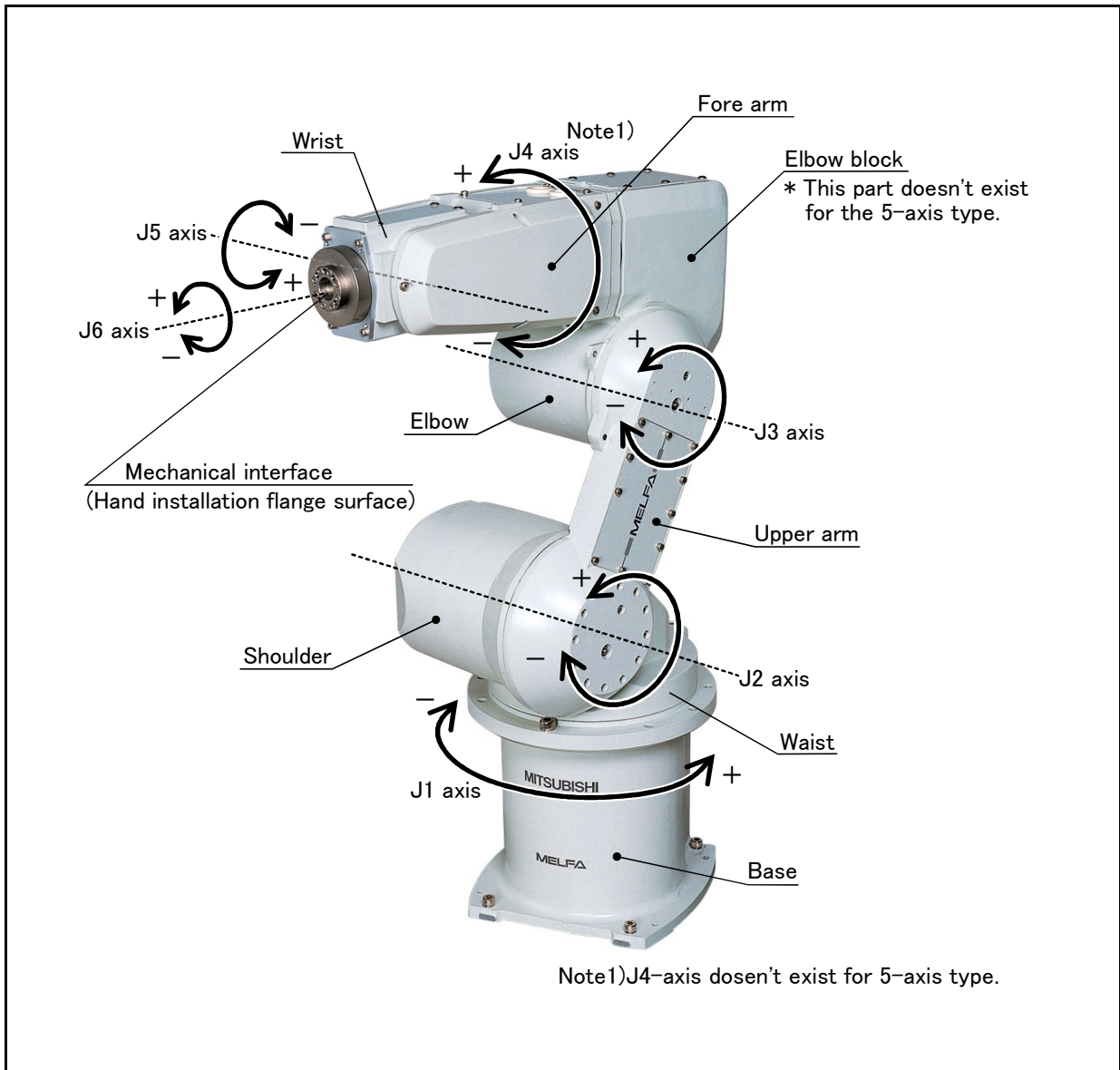

Fig.2-2 : Names of each part of the robot

2.4 Outside dimensions • Operating range diagram

(1) RV-3SB/3SBC (6-axis type)

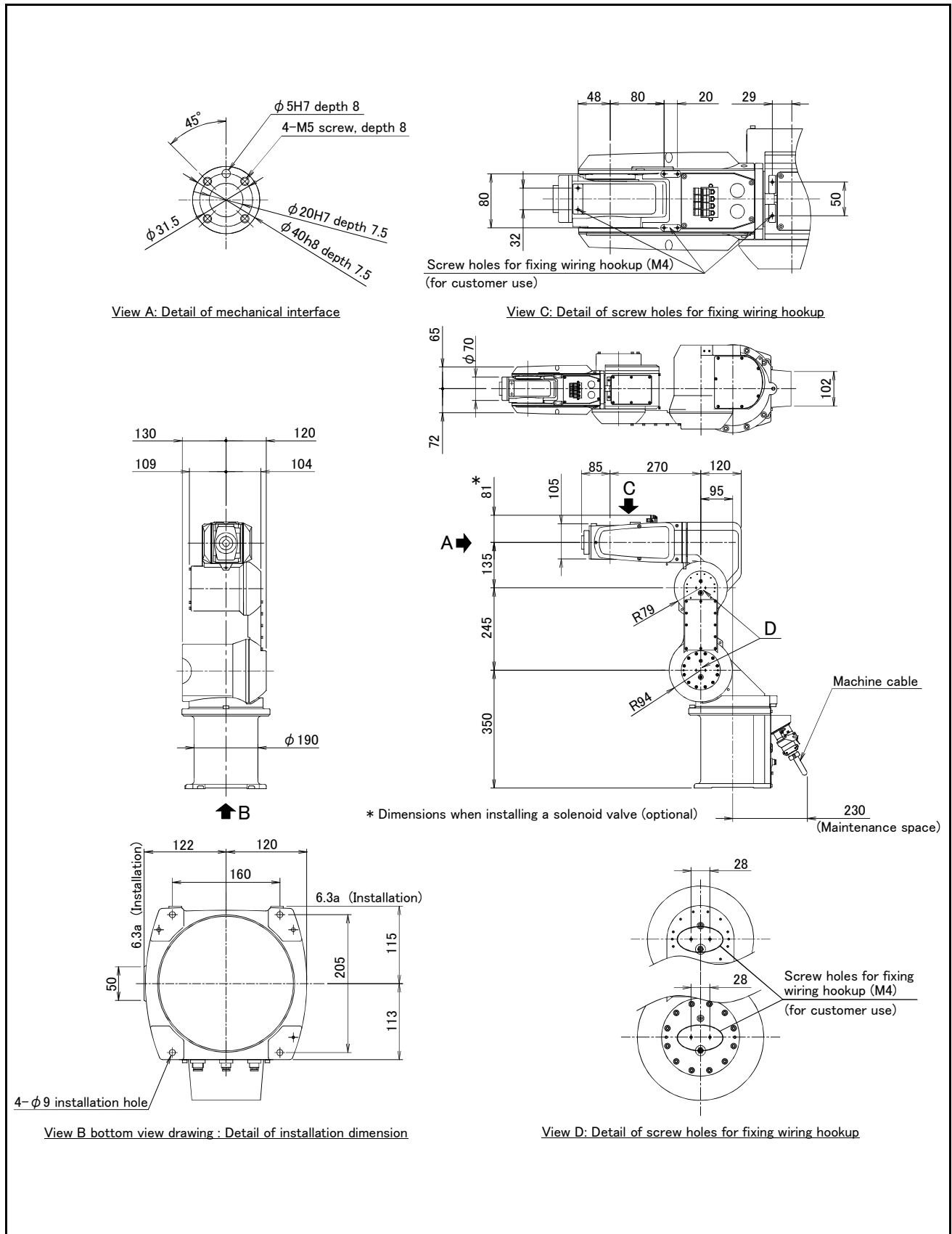

Fig.2-3 : Outside dimensions: RV-3SB/3SBC

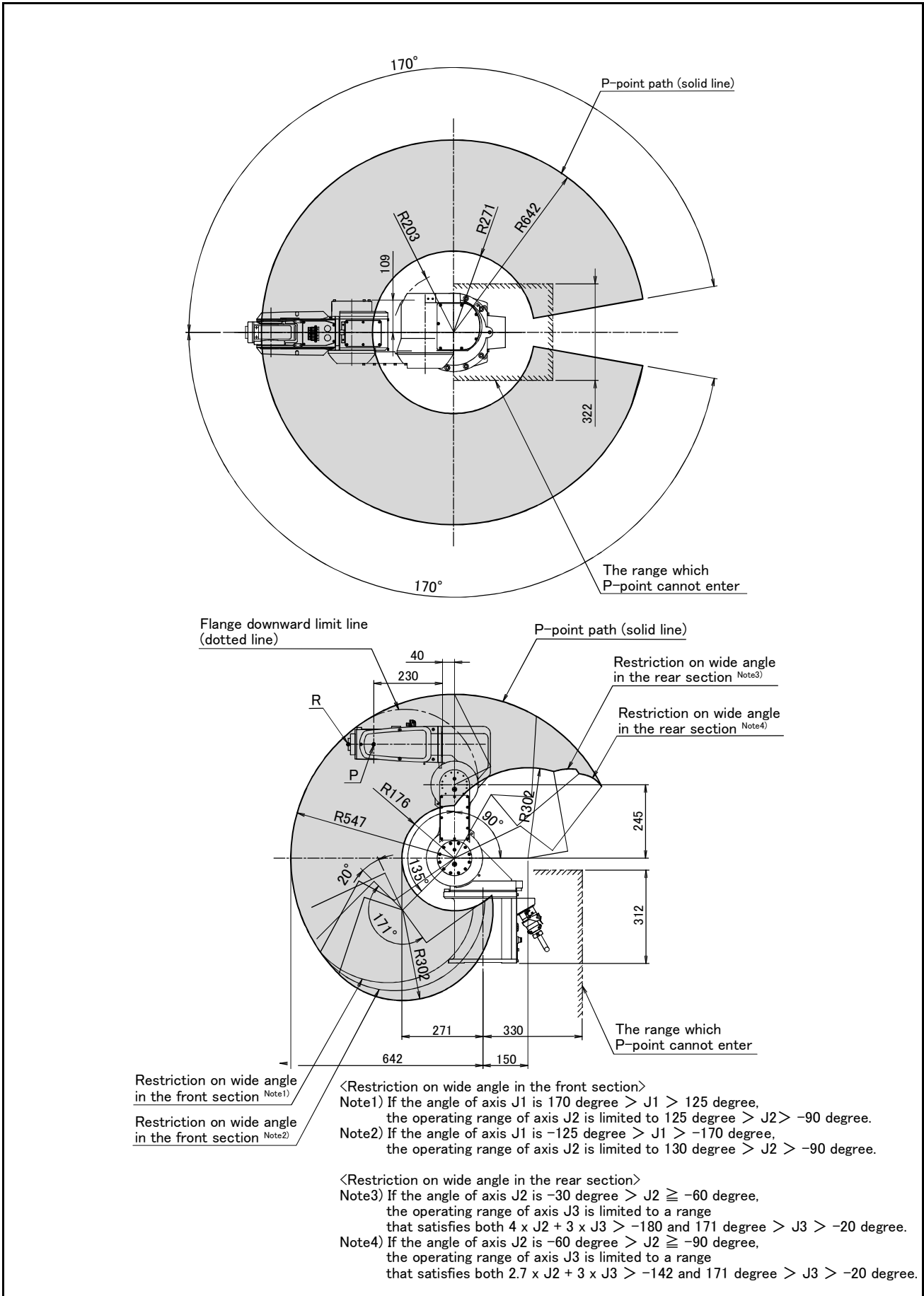

Fig.2-4 : Operating range diagram: RV-3SB/3SBC

(2) RV-3SJB/3SJBC (5-axis type)

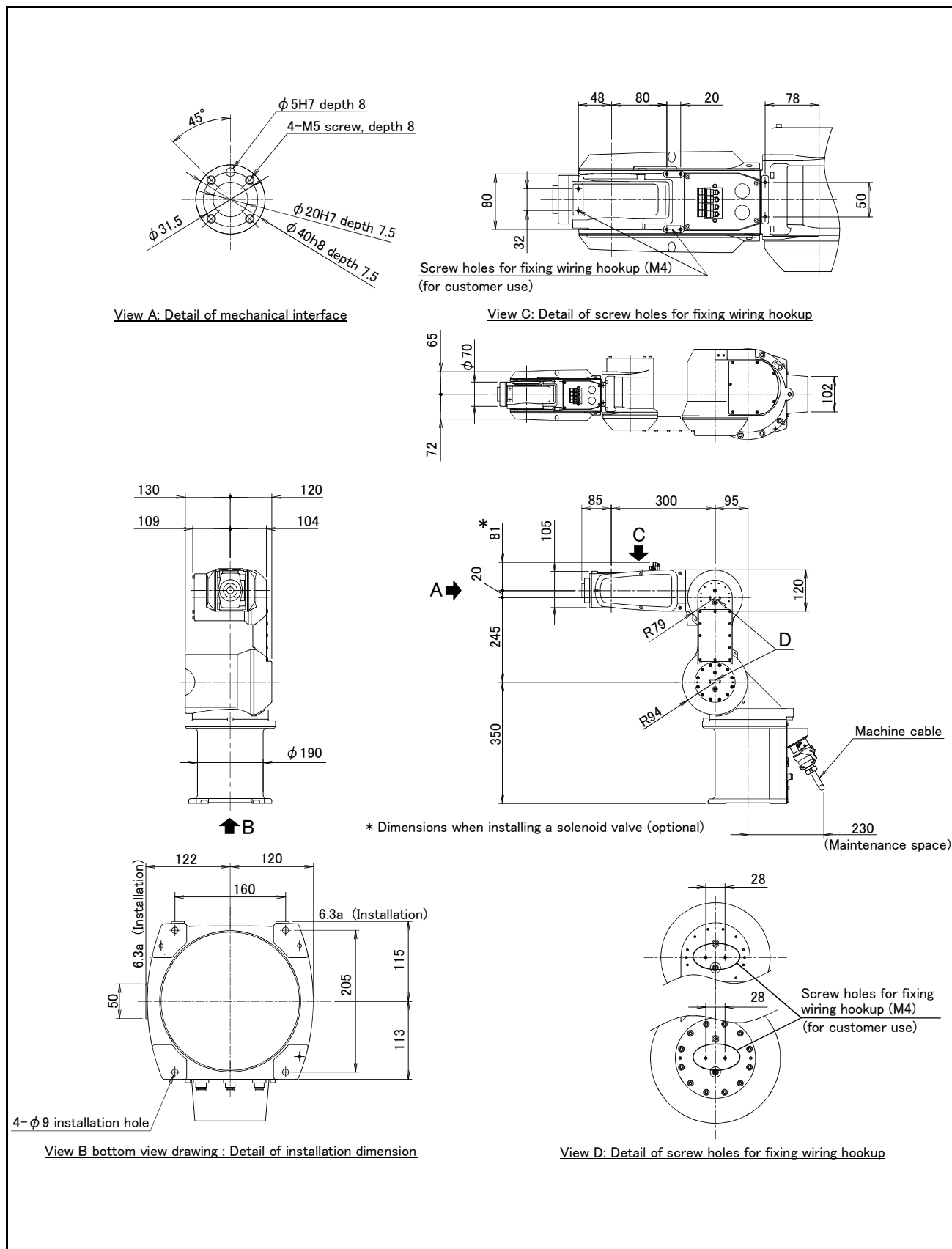

Fig.2-5 : Outside dimensions: RV-3SJB/3SJBC

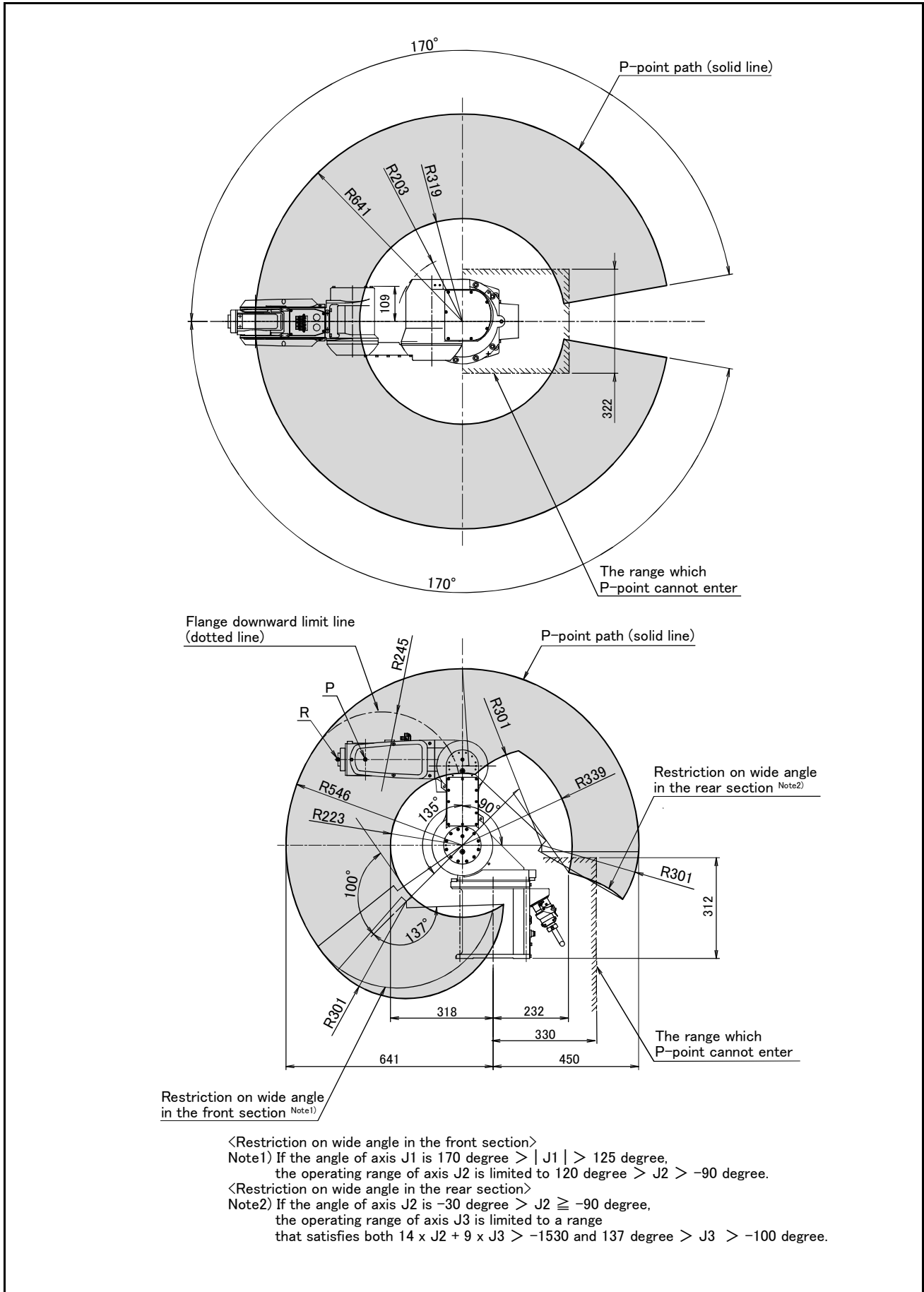

Fig.2-6 : Operating range diagram: RV-3SJB/3SJBC

2.5 Tooling

2.5.1 Wiring and piping for hand

Shows the wiring and piping configuration for a standard-equipped hand.

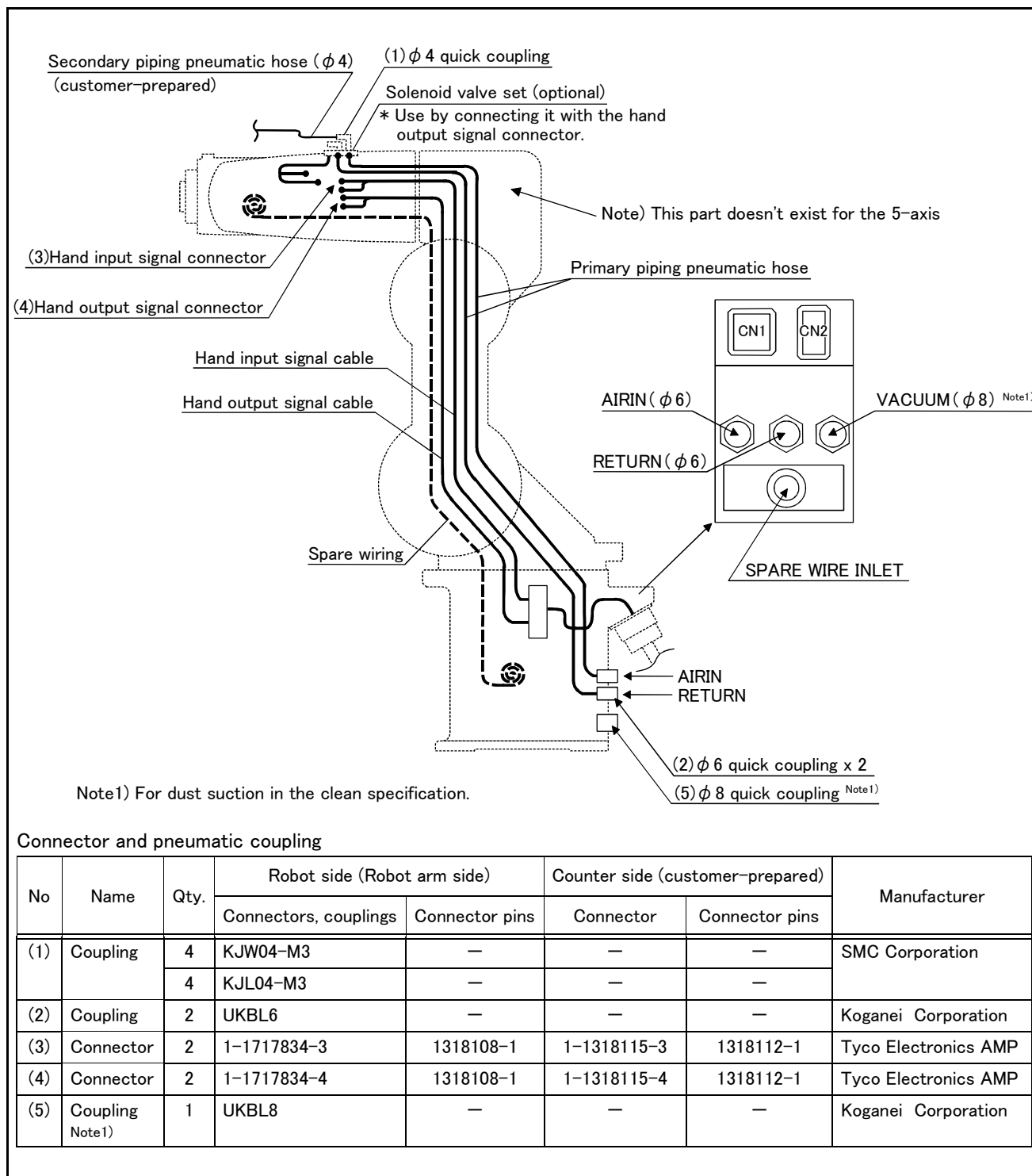

Fig.2-7 : Wiring and piping for hand

2.5.2 Internal air piping

(1) General-purpose environment/Oil mist specifications

- 1) The robot has two $\phi 6 \times 4$ urethane hoses from the pneumatic entrance on the base section to the shoulder cover.
- 2) One hose is the primary piping for the pneumatic equipment. The remaining pipe is used for air exhaust.
- 3) The optional solenoid is provided with a maximum of eight couplings for the $\phi 4$ air hose.
- 4) The pneumatic inlet in the base section has a $\phi 6$ pneumatic coupling bridge.
- 5) Refer to Page 34, "(3) Solenoid valve set" for details on the electronic valve set (optional).

(2) Clean type

- 1) The clean type basically includes the same piping as the standard type.
- 2) With the clean specification, a $\phi 8$ coupling is provided in the base section for suction inside the machine. For use, connect it to the suction port of the vacuum pump or the coupling on the "VACUUM" side of the vacuum generating valve. Moreover, to clean the exhaust from the vacuum pump or vacuum generator, use the exhaust filter (prepared by the customer). Table 2-6 shows the specifications of the vacuum generating valve.
- 3) To use the vacuum pump, assure a flow rate of 30 liters/min. or more.
- 4) Use clean air as the air supplied to the vacuum generator.

Table 2-6 : Vacuum generating valve specifications

Type	Maker	Air pressure
MEDT14	KONEGAI CORPORATION	0.2 to 0.6 MPa

2.5.3 Internal wiring for the pneumatic hand output cable

- 1) When the controller uses the optional pneumatic hand interface (2A-RZ365/RZ375), the hand output signal works as the pneumatic hand cable.
- 2) The hand output primary cable extends from the connector PCB of the base section to the inside of the forearm. (AWG#24(0.2mm²) \times 2 : 8 cables) The cable terminals have connector bridges for eight hand outputs. The connector names are GR1 and GR2.
To extend the wiring to the outside of the arm, a separate cable (optional "hand output cable 1S-GR35S-01" IP65 is recommended) is required.

2.5.4 Internal wiring for the hand check input cable

- 1) The hand output primary cable extends from the connector PCB of the base section to the inside of the forearm. (AWG#24(0.2mm²) \times 2 : 8 cables) The cable terminals have connector bridges for eight hand inputs. The connector names are HC1 and HC2. The terminal section is connected to the connector in the forearm section.
- 2) The hand check signal of the pneumatic hand is input by connecting this connector.
To extend the wiring to the outside of the arm, a separate cable (optional "hand input cable 1S-HC25C-01" IP65 is recommended) is required.

2.5.5 Spare Wiring

As spare wiring, four pairs of AWG#24(0.2mm²) cable (total of eight cores) are preinstalled between the base section and the forearm side section. Refer to the separate "Instruction Manual/ROBOT ARM SETUP & MAINTENANCE" for details.

Both ends of the wire terminals are unprocessed. Use them under the following circumstances:

- For folding as the hand output cable when installing the solenoid valve in outside the robot.
- For when installing six or more hand I/O points for the sensor in the hand section
(Connects to the parallel I/O general purpose input.)

2.5.6 Wiring and piping system diagram for hand

Shows the wiring and piping configuration for a standard-equipped hand.

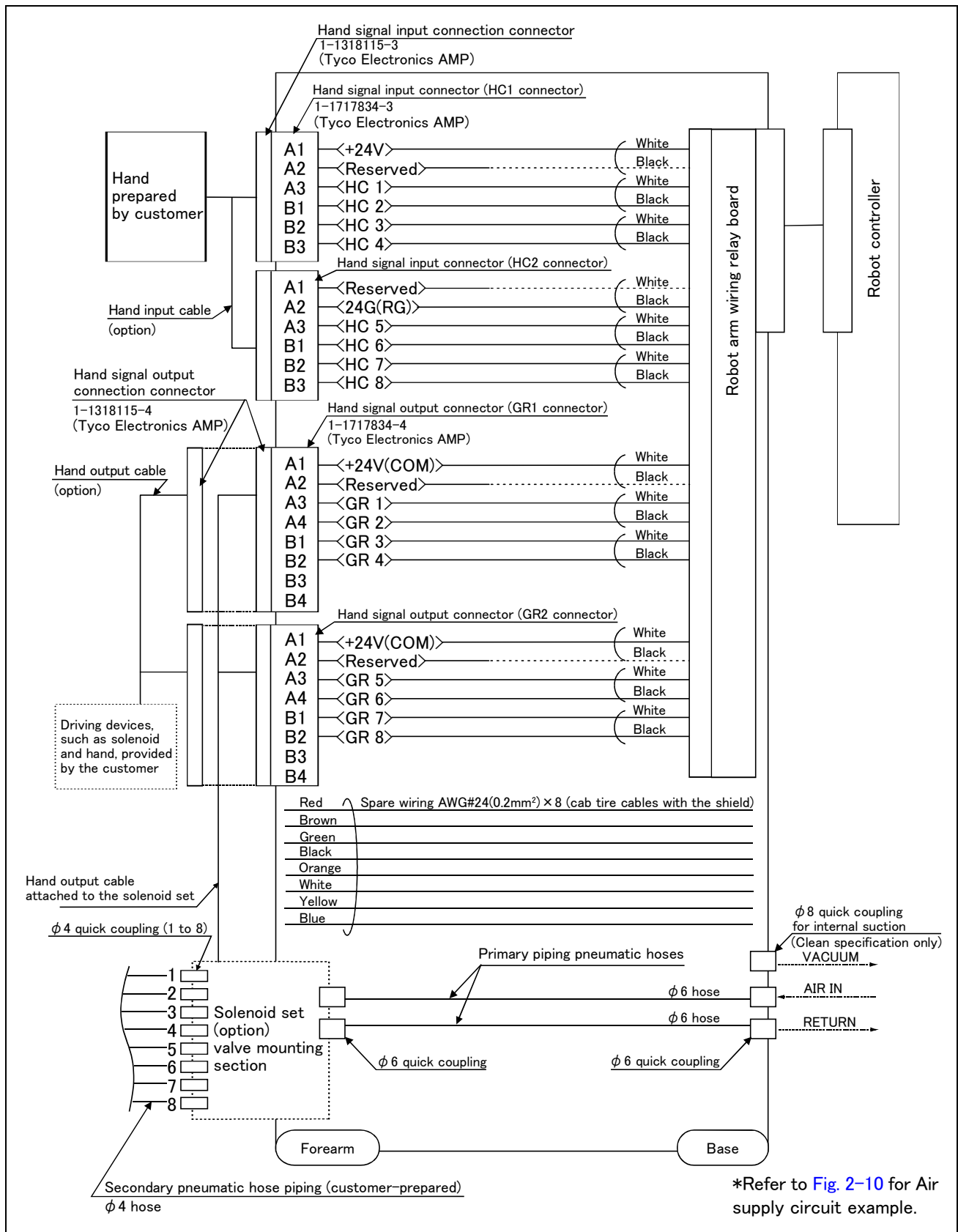

Fig.2-8 : Wiring and piping system diagram for hand and example the solenoid valve installation(Sink type)

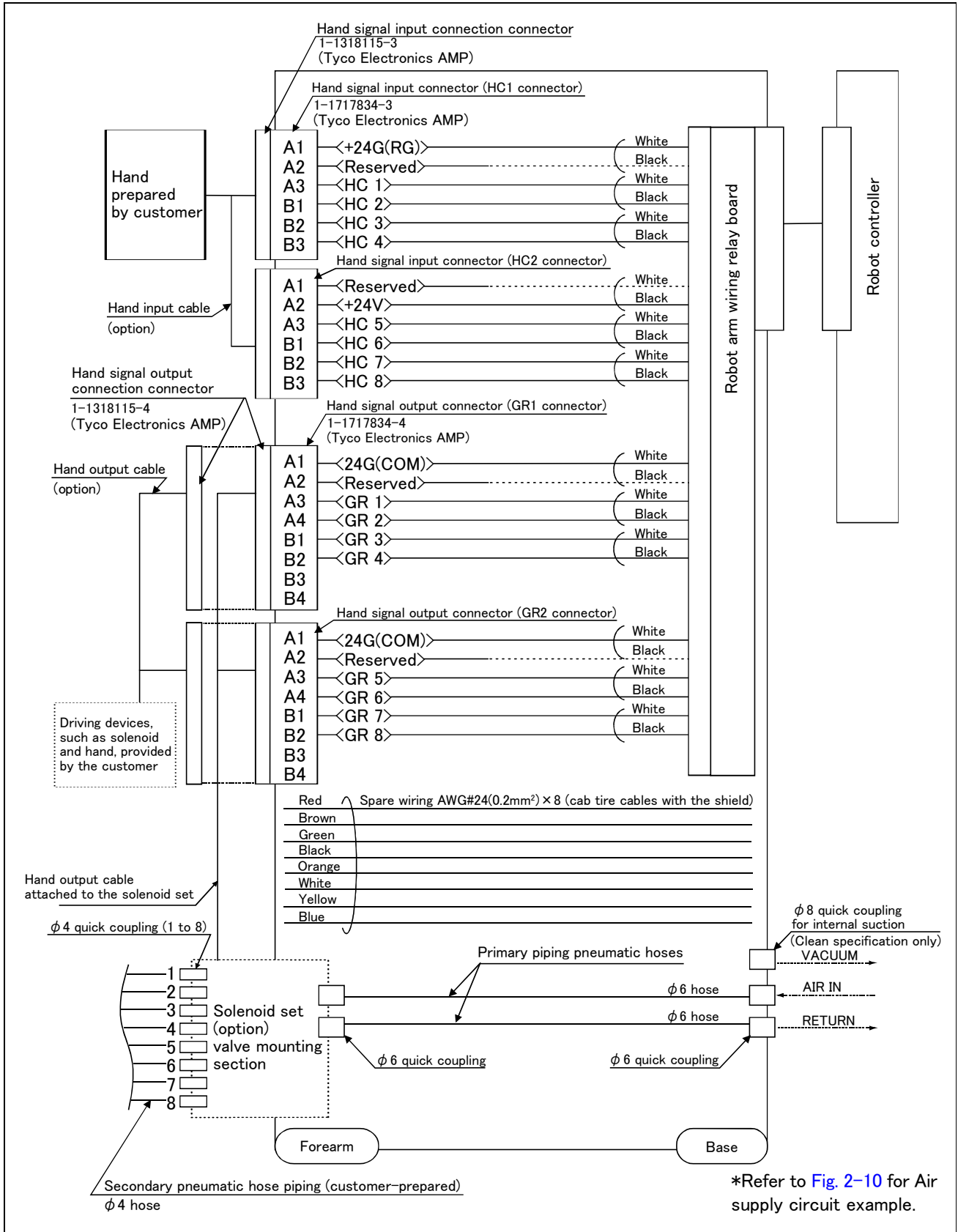

Fig.2-9 : Wiring and piping system diagram for hand and example the solenoid valve installation(Source type)

2.5.7 Electrical specifications of hand input/output

Table 2-7 : Electrical specifications of input circuit

Item		Specifications	Internal circuit
Type		DC input	<p><Sink type></p> <p><Source type></p> <p>* HCn = HC1 ~ HC8</p>
No. of input points		8	
Insulation method		Photo-coupler insulation	
Rated input voltage		12VDC/24VDC	
Rated input current		Approx. 3mA/approx. 7mA	
Working voltage range		DC10.2 to 26.4V(ripple rate within 5%)	
ON voltage/ON current		8VDC or more/2mA or more	
OFF voltage/OFF current		4VDC or less/1mA or less	
Input resistance		Approx. 3.3kΩ	
Response time	OFF-ON	10ms or less(DC24V)	
	ON-OFF	10ms or less(DC24V)	

Table 2-8 : Electrical specifications of output circuit

Item		Specification	Internal circuit
Type		Transistor output	<p><Sink type></p> <p><Source type></p> <p>* GRn = GR1 ~ GR8</p>
No. of output points		8	
Insulation method		Photo coupler insulation	
Rated load voltage		DC24V	
Rated load voltage range		DC21.6 to 26.4VDC	
Max. current load		0.1A/ 1 point (100%)	
Current leak with power OFF		0.1mA or less	
Maximum voltage drop with power ON		DC0.9V(TYP.)	
Response time	OFF-ON	2ms or less (hardware response time)	
	ON-OFF	2 ms or less (resistance load) (hardware response time)	
Fuse rating		1.6A (each one common) Cannot be exchanged	

Note) An optional air hand interface (2A-RZ365/RZ375) is required to use hand output.

2.5.8 Air supply circuit example

Fig. 2-10 shows an example of pneumatic supply circuitry.

- (1) Place diodes parallel to the solenoid coil.
- (2) If the factory's air pressure decreases, it may adversely affect the actual operations. As a preventive measure, attach a pressure switch to the air source as shown in Fig. 2-10 so as to make the circuit stop the robot in the event of air pressure drop. If the pressure switch does not improve the situation, use a device equipped with a mechanical lock mechanism or a mechanism that clamps by spring pressure.
- (3) The optional hand and solenoid valve are of an oilless type. If they are used, don't use any lubricator.
- (4) Supply clean air to the vacuum generation valve when you use clean type robot.

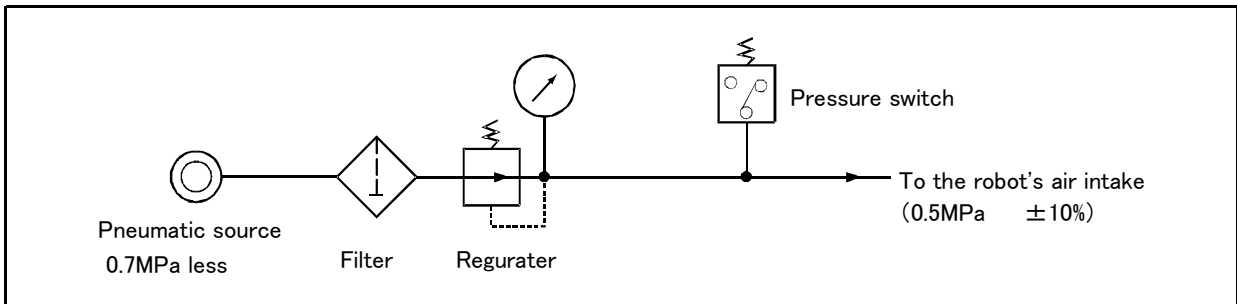

Fig.2-10 : Air supply circuit example for the hand

2.6 Shipping special specifications, options, and maintenance parts

2.6.1 Shipping special specifications

■ What are shipping special specifications?

Shipping special specifications are changed at the time of shipment from the factory. Consequently, customer need to confirm the delivery date.

To make changes to the specifications after shipment, service work must be performed at the work site or the robot must be returned for service.

■ How to order

- (1) Confirm beforehand when the factory special specifications can be shipped, because they may not be immediately available.
- (2) Order before the factory shipping date.
- (3) Specified method ····· Specify the part name, model, and robot model type.

(1) Machine cable

■ Order type: ● Fixed type 1S-02UCBL-03 (2m)

■ Outline

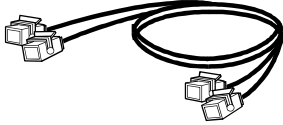

This cable is exchanged for the machine cable (5 m for fixed type) that was supplied as standard to shorten the distance between the controller and the robot arm.

■ Configuration

Table 2-9 : Configuration equipments and types

Part name		Type	Qty.	Remarks
Fixed	Set of signal and power cables	1S-02UCBL-03	1 set	2m
	Motor signal cable	BKO-FA0741H02	(1 cable)	
	Motor power cable	BKO-FA0768H02	(1 cable)	

Note) Standard 5 m (for fixed type) is not attached.

[Caution] Orders made after purchasing a robot are treated as purchases of optional equipment. In this case, the machine cable (5 m for fixed type) that was supplied as standard is not reclaimed. Please keep it in storage.

2.7 Options

■ What are options?

There are a variety of options for the robot designed to make the setting up process easier for customer needs. customer installation is required for the options. Options come in two types: "set options" and "single options".

1. Set optionsA combination of single options and parts that together, from a set for serving some purpose.
2. Single optionsThat are configured from the fewest number of required units of a part.
Please choose customer's purpose additionally.

(1) Machine cable extension

- Order type : ● Fixed type 1S-10CBL-03
- Flexed type 1S-15CBL-03 Note) The numbers in the boxes □□ refer the length.

■ Outline

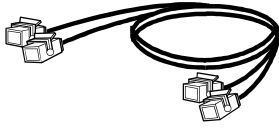

This cable is exchanged for the machine cable (5 m) that was supplied as standard to extend the distance between the controller and the robot arm.
 A fixed type and flexible type are available.
 Exchanges after shipment will be charged (for packaging, shipping costs).
 The fixing and flexible types are both configured of the motor signal cable and motor power cable .

■ Configuration

Table 2-10 : Configuration equipments and types

Part name		Type	Qty.		Remarks
			Fixed	Flexed	
Fixed	Set of signal and power cables	1S- □□ CBL-03	1 set	-	5m, 10m, or 15m each
	Motor signal cable	1S- □□ CBL(S)-01	(1 cable)	-	
	Motor power cable	1S- □□ CBL(P)-02	(1 cable)	-	
Flexed	Set of signal and power cables	1S- □□ LCBL-03	-	1 set	5m, 10m, or 15m each
	Motor signal cable	1S- □□ LCBL(S)-01	-	(1 cable)	
	Motor power cable	1S- □□ LCBL(P)-02	-	(1 cable)	
Nylon clamp		NK-14N	-	2 pcs.	
Nylon clamp		NK-18N	-	2 pcs.	
Silicon rubber			-	4 pcs.	

Note) The numbers in the boxes □□ refer the length.

■ Specifications

The specifications for the fixed type cables are the same as those for standard cables.
 Shows usage conditions for flexed type cables in [Table 2-11](#).

Table 2-11 : Conditions for the flexed type cables

Item		Specifications
Minimum flexed radius		100R or more
Cable bare, etc., occupation rate		50% or less
Maximum movement speed		2000mm/s or less
Guidance of life count		7.5 million times
Environmental proof		Oil-proof specification sheath (for silicon grease, cable sliding lubricant type)
Cable configuration	Motor signal cable	φ 6.5 x 5, φ 8.5 x 1 and φ 1.7 x 1
	Motor power cable	φ 6.5 x 10

[Caution] The guidance of life count may greatly differ according to the usage state (items related to [Table 2-11](#) and to the amount of silicon grease applied in the cable conduit.

[Caution] This option can be installed on clean-type, but its cleanliness is not under warranty.

■ Cable configuration

The configuration of the flexible cable is shown in [Table 2-12](#). Refer to this table when selecting the cable bare.

Table 2-12 : Cable configuration

Item	Motor signal cable 1S- □□ LCBL(S)-01			Motor power cable 1S- □□ LCBL(P)-02
	AWG#24(0.2mm ²)-4P	AWG#24(0.2mm ²)-7P	AWG#18(0.75mm ²)	AWG#18(0.75mm ²) -3C
No. of cores	Approx. ϕ 6mm	Approx. ϕ 8.5mm	Approx. ϕ 1.7mm	Approx. ϕ 6.5mm
No.of cables used	5 cables	1 cable	1 cable	10 cables
No. in total	7 cables			10 cables

Note) The square in the cable name indicates the cable length.

■ Fixing the flexible cable

- (1) Connect the connector to the robot arm .
- (2) Wind the silicon rubber around the cable at a position 300 to 400 mm from the side of robot arm and extension section as shown in [Fig. 2-11](#), and fix with the nylon clamp to protect the cable from external stress.

When using the CR1B-571 controller

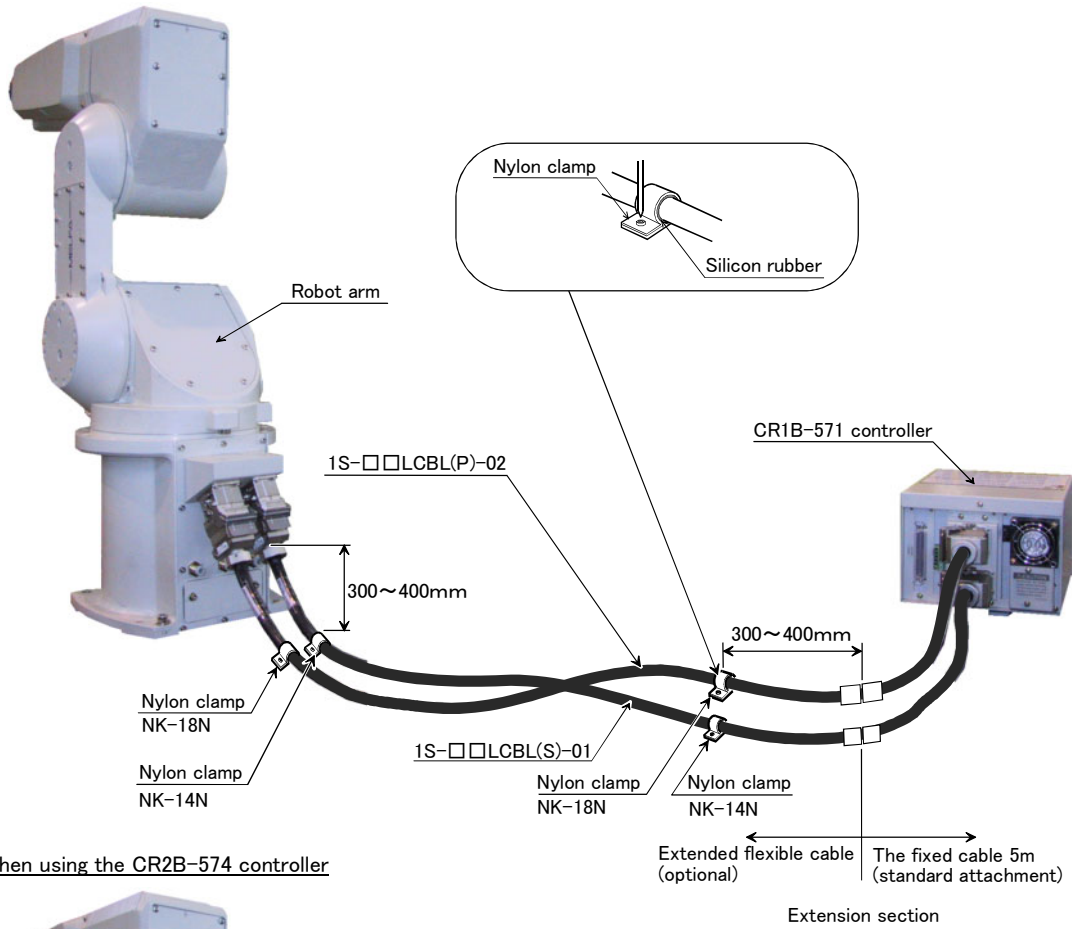

When using the CR2B-574 controller

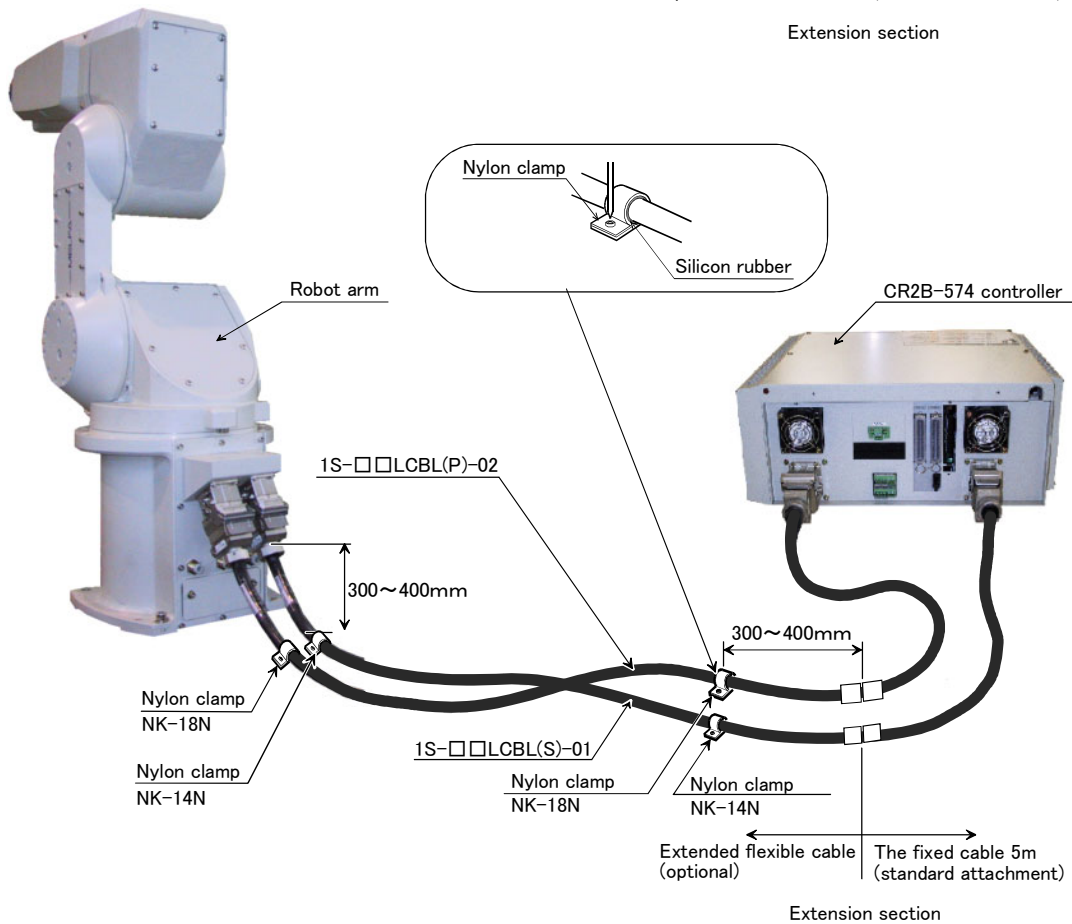

Fig.2-11 : Fixing the flexible cable

(2) Changing the operating range

■ Order type: 1S-DH-03

■ Outline



The J1 axis operating range is limited by the robot arm's mechanical stopper and the controller parameters.

If the axis could interfere with the peripheral devices, etc., and the operating range need to be limited, use this.

■ Configuration

Table 2-13 : Configuration devices

Part name	Type	Qty.	Remarks
Stopper for changing the operating range	1S-DH-03	2 pcs.	Hexagon socket bolt: M10 x 20 plating (strength classification 10.9)

■ Specifications

Table 2-14 : Specifications

Axis		Standard	Changeable angle
J1	+ side	+170 degree	One point from +120 degree, +90 degree, +60 degree, +30 degree
	- side	-170 degree	One point from -120 degree, -90 degree, -60 degree, -30 degree

(1) The changeable angle shown in [Table 2-14](#) indicates the operation range by the software.

The limit by the mechanical stopper is positioned 2.5 degrees outward from that angle, so take care when designing the layout.

(2) The changeable angle can be set independently on the + side and - side.

(3) The operating range is changed with robot arm settings and parameter settings. Refer to the separate "Instruction Manual/ROBOT ARM SETUP & MAINTENANCE" or "Instruction Manual/Detailed Explanation of Functions and Operations" for details.

(3) Solenoid valve set

- Order type: One set: 1S-VD01-02(Sink type)/1S-VD01E-02(Source type)
 Two sets: 1S-VD02-02(Sink type)/1S-VD02E-02(Source type)
 Three sets: 1S-VD03-02(Sink type)/1S-VD03E-02(Source type)
 Four sets: 1S-VD04-02(Sink type)/1S-VD04E-02(Source type)

■ Outline

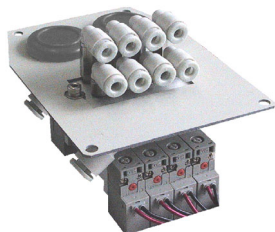

The solenoid valve set is an option that is used for controlling toolings when various toolings, such as the hand, are installed at the end of the arm. All have double solenoid specification, and either one or two or three sets can be selected. This solenoid valve set has a hand output cable attached to the solenoid valve. Also, for easy installation of this electromaagnetic set onto the robot, it comes equipped with a manifold, couplings, silencers, among other things.

When using the robot arm's hand output signal, the pneumatic hand interface option^{Note1)} must be installed on the separate controller.

■ Configuration

Table 2-15 : Configuration equipment

Part name	Type	Q'ty				Remark
		One set	Two sets	Three sets	Four sets	
Solenoid valve set (1 set)	1S-VD01-02/ 1S-VD01E-02	1 pc.	—	—	—	Connecting the Page 37, "(5) Hand output cable". M4x8 four screws (installation screws). 1S-VD01-02/VD02-02/VD03-02/VD04-02 are the sink type. 1S-VD01E-02/VD02E-02/VD03E-02/VD04E-02 are the source type.
Solenoid valve set (2 sets)	1S-VD02-02/ 1S-VD02E-02	—	1 pc.	—	—	
Solenoid valve set (3 sets)	1S-VD02-02/ 1S-VD02E-02	—	—	1 pc.	—	
Solenoid valve set (4 sets)	1S-VD02-02/ 1S-VD02E-02	—	—	—	1 pc.	

■ Specifications

Table 2-16 : Valve specifications

Item	Specifications
Number of positions	2
Port	5 ^{Note2)}
Valve function	Double solenoid
Operating fluid	Clean air ^{Note3)}
Operating method	Internal pilot method
Effective sectional area (CV value)	0.64mm
Oiling	Unnecessary
Operating pressure range	0.1 to 0.7MPa
Guaranteed proof of pressure	1.0MPa or more
Response time	22msec or less (at 0.5 MPa)
Max. operating frequency	5c/s
Ambient temperature	-5 to 50 °C (However, there must be no condensation.)

Note2) Couplings of unused solenoid valves must be blocked with plugs. If they are not blocked, supplied air will blow out from the couplings, lowering the air pressure of the solenoid valves being used and making them nonfunctional (recommended plugs: KQ2P-04 plugs made by SMC).



CAUTION

Note3) The air to be provided must be clean, i.e., filtered with a mist separator or air filter. Failing to do so may lead to malfunctions.

Table 2-17 : Solenoid specifications

Item	Specifications
Coil rated voltage	DC24V ± 10%
Power consumption	0.05W
Voltage protection circuit with power surge protection	Diode

Note1) 1S-VD0*-02 (sink type) corresponds to 2A-RZ365 and 1S-VD0*E-02 (source type) corresponds to 2A-RZ375.

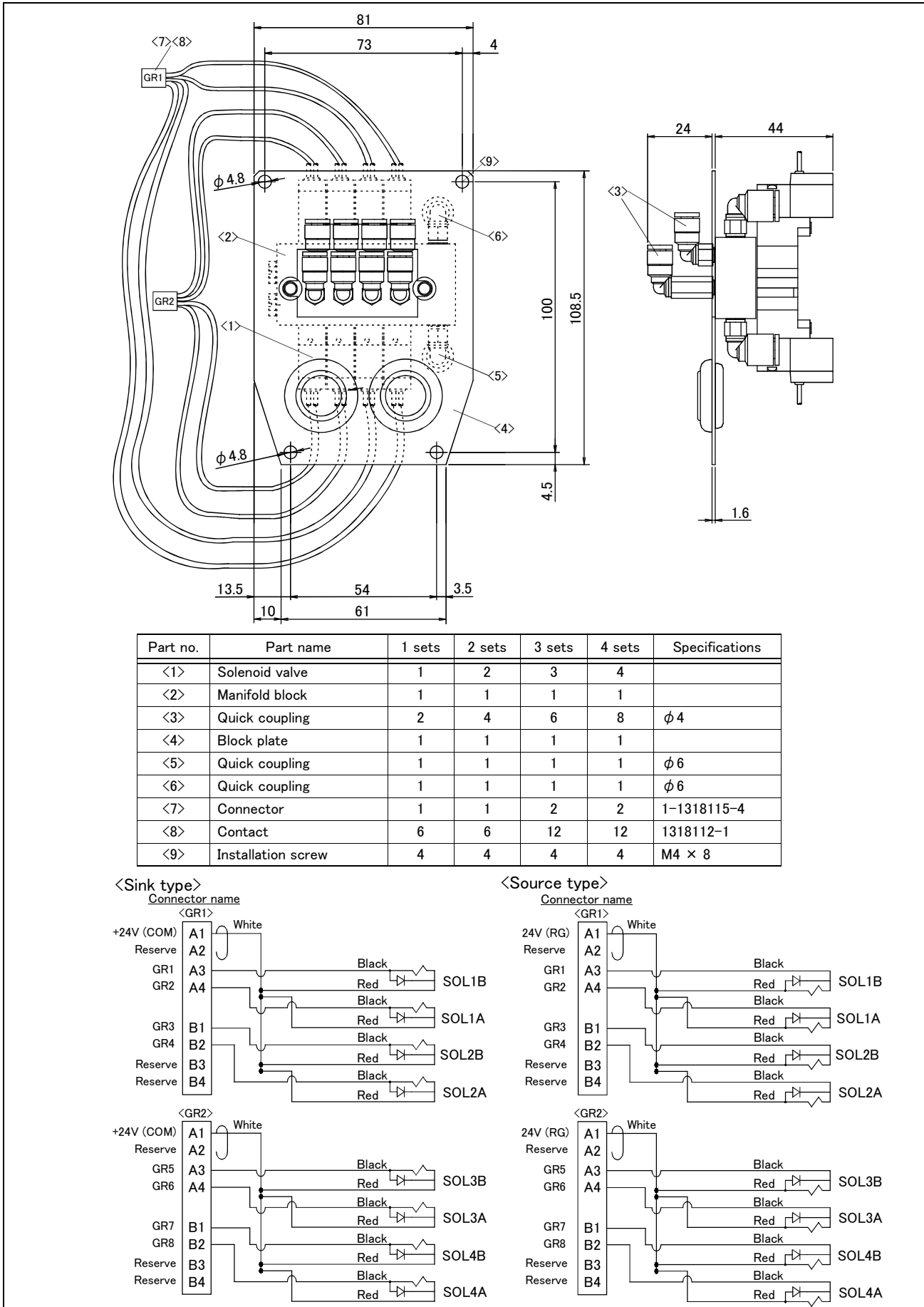
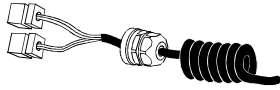

Fig.2-12 : Outline dimensional drawing

(4) Hand input cable

■ Order type: 1S-HC25C-01

■ Outline



The hand input cable is used for customer-designed pneumatic hands. It is necessary to use this to receive the hand's open/close confirmation signals and grasping confirmation signals, at the controller. One end of the cable connects to the connector for hand input signals, which is in the wrist section of the hand. The other end of the cable connects to the sensor inside the hand customer designed.

■ Configuration

Table 2-18 : Configuration equipment

Part name	Type	Qty.	Remarks
Hand input cable	1S-HC25C-01	1 cable	

■ Specifications

Table 2-19 : Specifications

Item	Specifications	Remarks
Size x cable core	AWG#24 (0.2mm ²) × 12	One-sided connector, one-sided cable bridging
Total length	800mm (Including the curl section, which is 300mm long)	

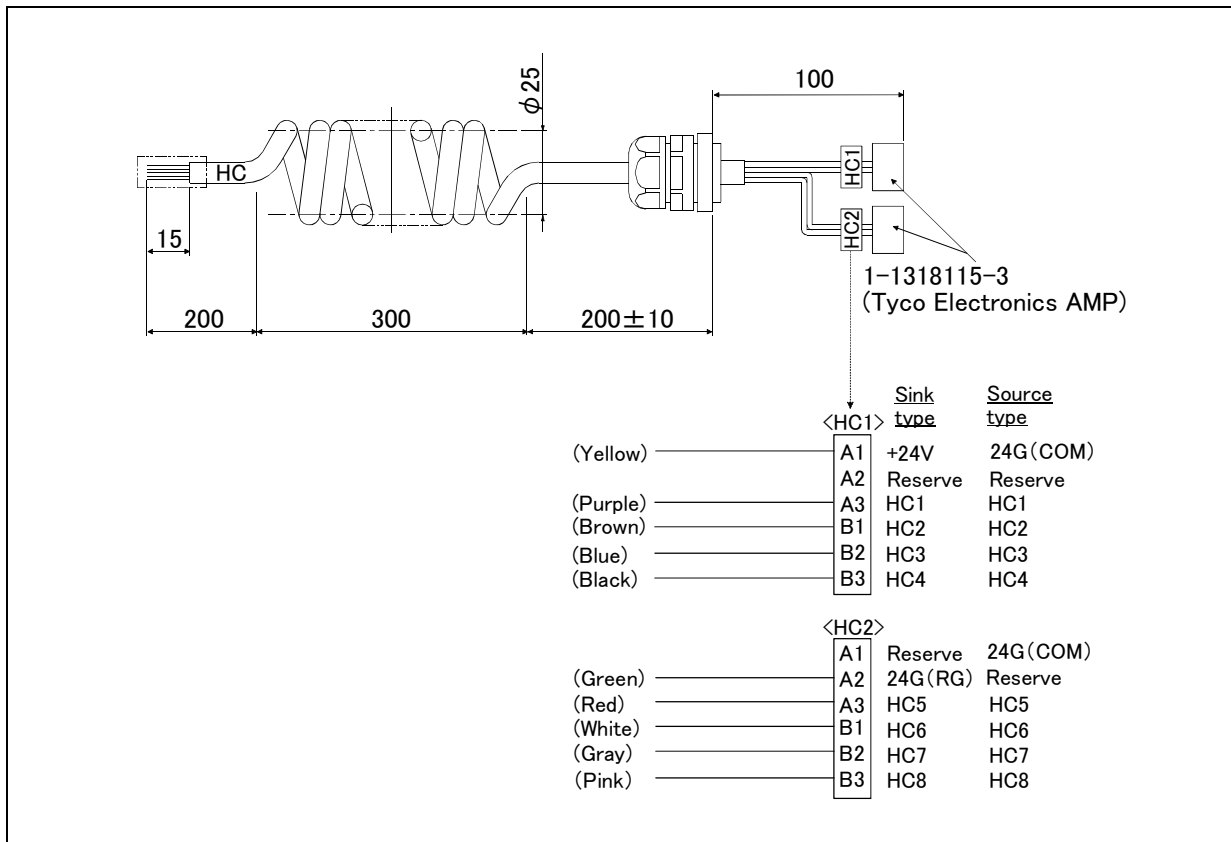

Fig.2-13 : Outside dimensional drawing and pin assignment

[Caution] This option can be installed on clean-type, but its cleanliness is not under warranty.

(5) Hand output cable

■ Order type: Four sets:1S-GR35S-01

■ Outline

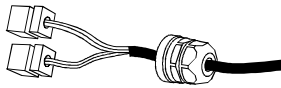

The hand output cable (solenoid valve connection cable) is an option that is used when a solenoid valve other than one of the solenoid valve set options is used. One end of the cable has a connector that connects to the input terminal inside the robot. The other end of the cable is connected.

■ Configuration

Table 2-20 : Configuration equipment

Part name	Type	Qty.	Remarks
Hand output cable	1S-GR35S-01	1 cable	For four sets

■ Specifications

Table 2-21 : Specifications

Item	Specifications	Remarks
Size x Cable core	AWG#24(0.2mm ²) x 12 cores	One side connector and one side cable connection
Total length	400mm	

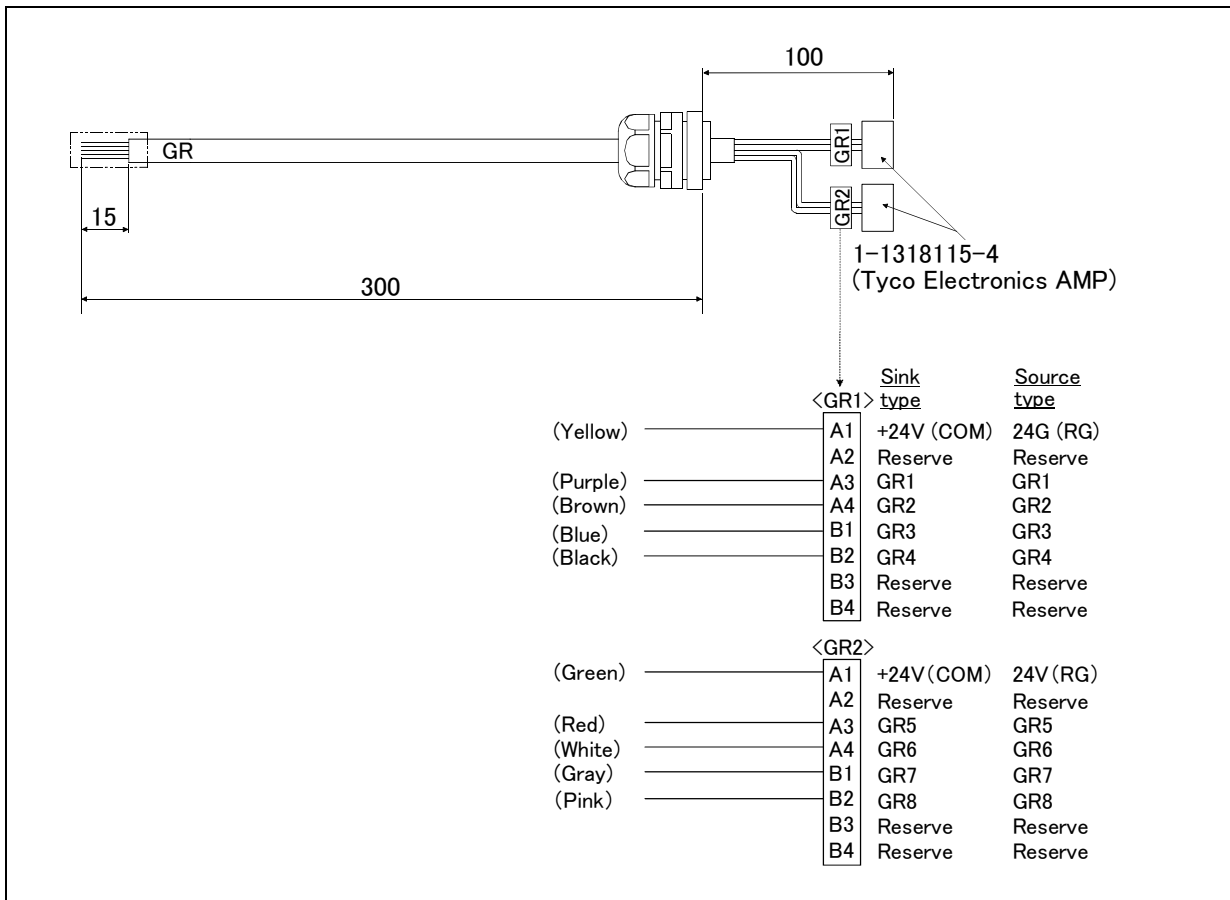

Fig.2-14 : Outline dimensional drawing and pin assignment

(6) Hand curl tube

- Order type: One set :1E-ST0402C
- Two sets :1E-ST0404C
- Three sets :1E-ST0406C
- Four sets :1E-ST0408C

■ Outline

The hand curl tube is a curl tube for the pneumatic hand.

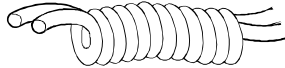

■ Configuration

Table 2-22 : Configuration equipment

Part name	Type	Qty.	Remarks
Hans curl tube (One set: 2 pcs.)	1E-ST0402C	1 pc.	Φ4 tube, 2pcs.
Hans curl tube (Two set: 4 pcs.)	1E-ST0404C	1 pc.	Φ4 tube, 4pcs.
Hans curl tube (Three set: 6 pcs.)	1E-ST0406C	1 pc.	Φ4 tube, 6pcs.
Hans curl tube (Four set: 8 pcs.)	1E-ST0408C	1 pc.	Φ4 tube, 8pcs.

■ Specifications

This option can be installed on clean-type, but its cleanliness is not under warranty.

Table 2-23 : Specifications

Item	Specifications
Material	Urethane
Size	Outside diameter: ϕ x Inside diameter: ϕ

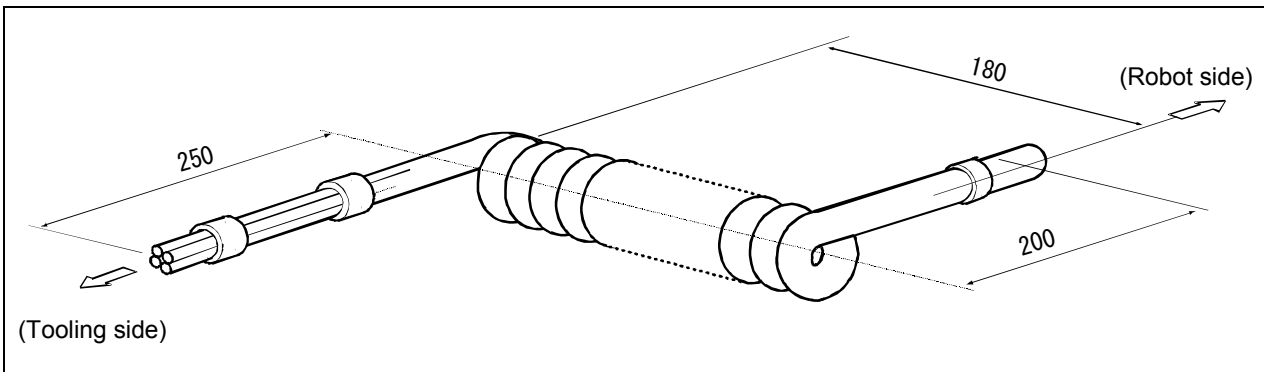

Fig.2-15 : Outline dimensional drawing

[Caution] This option can be installed on clean-type, but its cleanliness is not under warranty.

2.8 Maintenance parts

The consumable parts used in the robot arm are shown in [Table 2-24](#). Purchase these parts from the designated maker or dealer when required. Some Mitsubishi-designated parts differ from the maker's standard parts. Thus, confirm the part name, robot arm and controller serial No. and purchase the parts from the dealer.

Table 2-24 : Consumable part list

No.	Part name	Type	Usage place	Qty.	Supplier
1	Grrase	SK-1A	Reduction gears of each axis	As needed	Mitsubishi Electric System & Service;Co.,Ltd.
2	Lithium battery	A6BAT	In the battery cover A	4 pcs.	

3 Controller

3.1 Standard specifications

3.1.1 Standard specifications

Table 3-1 : Standard specifications of controller (CR1B-571)

Item		Unit	Specification	Remarks
Type			CR1B-571	
Number of control axis			Simultaneously 6(Maximum)	
CPU			64 bit RISC, and DSP	
Memory capacity	Programmed positions and No. of steps	point step	2,500 5,000	
	Number of programs		88	
	Robot language			MELFA-BASIC IV or MOVEMASTER COMMAND
Teaching method			Pose teaching method ,MDI method	
External input and output	Input and output	point	16/16	Max. 240/240 ^{Note1)}
	Dedicated input/output	point	Assigned with general-purpose input/output	"STOP" 1 point is fixed
	Hand open/close input/output	point	Input 8 point/Output 0 point	Up to 8 output points can be added as an option ^{Note2)}
	Emergency stop input	point	1	Single emergency line
	Door switch input	point	1	Single door switch line
	Emergency stop output	point	1	Single emergency line
Interface	RS-232C	port	1	For expansion such as the personal computer, Vision sensor
	RS-422	port	1	Dedicated for T/B
	Hand dedicated slot	slot	1	Dedicated for pneumatic hand interface
	Expansion slot	slot	0	Can be expanded to up to 3 slots by mounting the expansion option box.
	Robot input/output link	channel	1	Used for general-purpose input/output (Max. 240/240)
Power source	Input voltage range	V	1-phase, AC180 to 253	^{Note3)}
	Power capacity	KVA	1.0	Does not include rush current ^{Note4)}
Outline dimensions		mm	212(W)x290(D)x151(H)	Excluding protrusions
Mass		kg	Approx. 8	
Construction			Self-contained floor type, Opened type	IP20 ^{Note5)}
Operating temperature range		deg.	0 to 40	
Ambient humidity		%RH	45 to 85	Without dew drops
Grounding		Ω	100 or less	D class grounding earth ^{Note6)}
Paint color			Light gray	Munsell 0.08GY7.64/0.81

Note1) It is the value when seven maximums expand (224/224) the Parallel I/O unit.
(2A-RZ361 or 2A-RZ371:Input 32 points / Output 32 points.)

Note2) It is when an pneumatic hand interface (2A-RZ365 or 2A-RZ375) is installed.

Note3) Please use the controller with an input power supply voltage fluctuation rate of 10% or less.

Note4) The power capacity (1.0kVA) is the rating value for normal operation. The power capacity does not include the rush current when the power is turned ON. The power capacity is a guideline and the actual operation is affected by the input power voltage. The power consumption in the specific operation pattern with the RV-3SB/3SJB series is approx. 0.3kw

Note5) The controller (CR1B-571) of this robot is a general environment specification. (Refer to [Page 42, "3.1.2 Protection specifications and operating supply"](#)) If the robot is used in an oil mist environment, use the optional controller protection box (CR1B-MB) to protect the controller from the oil mist environment. Install to the place not to influence the cleanliness when using in the clean environment. (Refer to [Page 15, "2.2.6 Clean specifications"](#))

Note6) The robot must be grounded by the customer.

Table 3-2 : Standard specifications of controller (CR2B-574)

Item		Unit	Specification	Remarks
Type			CR2B-574	
Number of control axis			Simultaneously 6(Maximum)	
CPU			64 bit RISC, and DSP	
Memory capacity	Programmed positions and No. of steps	point step	2,500 5,000	
	Number of programs		88	
Robot language			MELFA-BASIC IV or MOVEMASTER COMMAND	
Teaching method			Pose teaching method ,MDI method	
External input and output	input and output	point	32/32	Max. 256/256 ^{Note1)}
	Dedicated input/output	point	Assigned with general-purpose input/output	"STOP" 1 point is fixed
	Hand open/close input/output	point	Input 8 point/Output 0 point	Up to 8 output points can be added as an option ^{Note2)}
	Emergency stop input	point	1	Dual emergency line
	Door switch input	point	1	Dual door switch line
	Emergency stop output	point	1	Dual emergency line
Interface	RS-232C	port	1	For expansion such as the personal computer, Vision sensor
	RS-422	port	1	Dedicated for T/B
	Hand dedicated slot	slot	1	Dedicated for pneumatic hand interface
	Expansion slot	slot	3	
	Memory expand slot	slot	1	Memory option
	Robot input/output link	channel	1	Used for general-purpose input/output (Max. 256/256)
Power source	Input voltage range	V	1-phase, AC180 to 253	^{Note3)}
	Power capacity	KVA	1.0	Does not include rush current ^{Note4)}
Outline dimensions		mm	460(W)x400(D)x200(H)	Excluding protrusions
Mass		kg	Approx. 20	
Construction			Self-contained floor type, Opened type (IP20) ^{Note5)}	
Operating temperature range		deg.	0 to 40	
Ambient humidity		%RH	45 to 85	Without dew drops
Grounding		Ω	100 or less	D class grounding earth ^{Note6)}
Paint color			Light gray	Munsell 0.08GY7.64/0.81

Note1) It is the value when seven maximums expand (224/224) the Parallel I/O unit. (2A-RZ361 or 2A-RZ371:Input 32 points / Output 32 points.)

Note2) It is when a pneumatic hand interface (2A-RZ365 or 2A-RZ375) is installed.

Note3) Please use the controller with an input power supply voltage fluctuation rate of 10% or less.

Note4) The power capacity (1.0kVA) is the rating value for normal operation. The power capacity does not include the rush current when the power is turned ON. The power capacity is a guideline and the actual operation is affected by the input power voltage. The power consumption in the specific operation pattern with the RV-3SB/3SB series is approx. 0.3kW.

Note5) The CR2B-574 controller of this robot is a general environment specification (Refer to [Page 42, "3.1.2 Protection specifications and operating supply"](#)). If you intend to use the controller in oil mist or dusty environments, please contact your nearest Mitsubishi branch or dealer. Install to the place not to influence the cleanliness when using in the clean environment (Refer to [Page 15, "2.2.6 Clean specifications"](#)).

Note6) The robot must be grounded by the customer.

3.1.2 Protection specifications and operating supply

A protection method complying with the IEC Standard IP20(Opened type) is adopted for the controller.

The IEC IP symbols refer only to the degree of protection between the solid and the fluids, and don't indicated that any special protection has been constructed for the prevention against oil and water.

- The IEC IP20

It indicates the protective structure that prevents an iron ball $12^{+0.05}_0$ mm diameter, which is being pressed with the power of $3.1 \text{ kg} \pm 10\%$, from going through the opening in the outer sheath of the supplied equipment.

Refer to the section [Page 112, "6.2 Working environment"](#) for details on the working environment.



If the robot is used in an oil mist environment, use the optional controller protection box (CR1B-MB) to protect the controller from the oil mist environment(CR1B-571 controller only).

Refer to the section [Page 67, "\(3\) Controller protection box"](#) for details on the controller protection box.

3.2 Names of each part

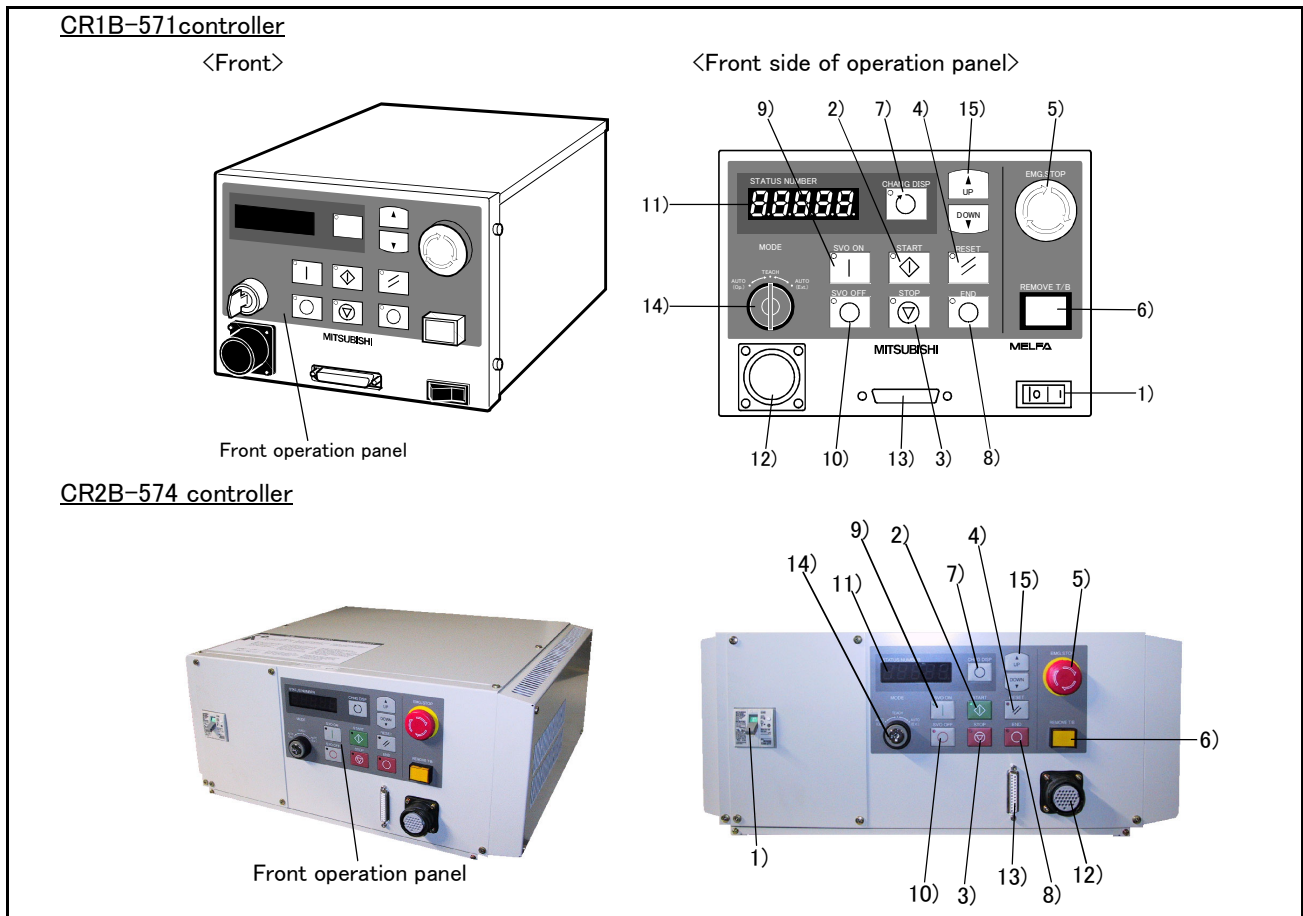

Fig.3-1 : Names of controller parts

- 1) POWER switch..... This turns the control power ON/OFF.
- 2) START button..... This executes the program and operates the robot. The program is run continuously.
- 3) STOP button This stops the robot immediately. The servo does not turn OFF.
- 4) RESET button This resets the error. This also resets the program's halted state and resets the program.
- 5) Emergency stop switch..... This stops the robot in an emergency state. The servo turns OFF.
- 6) T/B remove switch..... This is used to connect/disconnect the T/B without turning OFF the controller's control power.
- 7) CHNGDISP button This changes the details displayed on the display panel in the order of "Override" → "Program No." → "Line No.".
- 8) END button..... This stops the program being executed at the last line or END statement.
- 9) SVO.ON button..... This turns ON the servo power. (The servo turns ON.)
- 10) SVO.OFF button..... This turns OFF the servo power. (The servo turns OFF.)
- 11) STATUS NUMBER
(display panel)..... The alarm No., program No., override value (%), etc., are displayed.
- 12) T/B connection connector This is a dedicated connector for connecting the T/B.
- 13) Personal computer
connection connector..... This is an RS-232C specification connector for connecting the personal computer.
- 14) MODE key switch..... This changes the robot's operation mode. ^{Note)}
 - AUTO (Op.)..... Only operations from the controller are valid. Operations for which the operation mode must be at the external device or T/B are not possible.
 - TEACH When the T/B is valid, only operations from the T/B are valid. Operations for which the operation mode must be at the external device or controller are not possible.
 - AUTO (Ext.)..... Only operations from the external device are valid. Operations for which the operation mode must be at the T/B or controller are not possible.
- 15) UP/DOWN button This scrolls up or down the details displayed on the "STATUS. NUMBER" display panel.

 CAUTION

Note) The servo will turn OFF when the controller's [MODE] switch is changed.
Note that axes not provided with brakes could drop with their own weight.

Carry out the following operations to prevent the servo from turning OFF when the [MODE] switch is changed.

The servo on status can be maintained by changing the mode with keeping pressing lightly the deadman switch of T/B. The operating method is shown below.

■ When the mode is changed from TEACH to AUTO.

- 1) While holding down the deadman switch on the T/B, set the [ENABLE/DISABLE] switch to "DISABLE".
- 2) While holding down the deadman switch on the T/B, set the controller [MODE] switch to "AUTO".
- 3) Release the T/B deadman switch.

■ When the mode is changed from AUTO to TEACH.

- 1) While the [ENABLE/DISABLE] switch on the T/B is "DISABLE", hold down the deadman switch.
- 2) While holding down the deadman switch on the T/B, set the controller [MODE] switch to "TEACH".
- 3) While holding down the deadman switch on the T/B, set the [ENABLE/DISABLE] switch to "ENABLE", then do the operation of T/B that you wish.

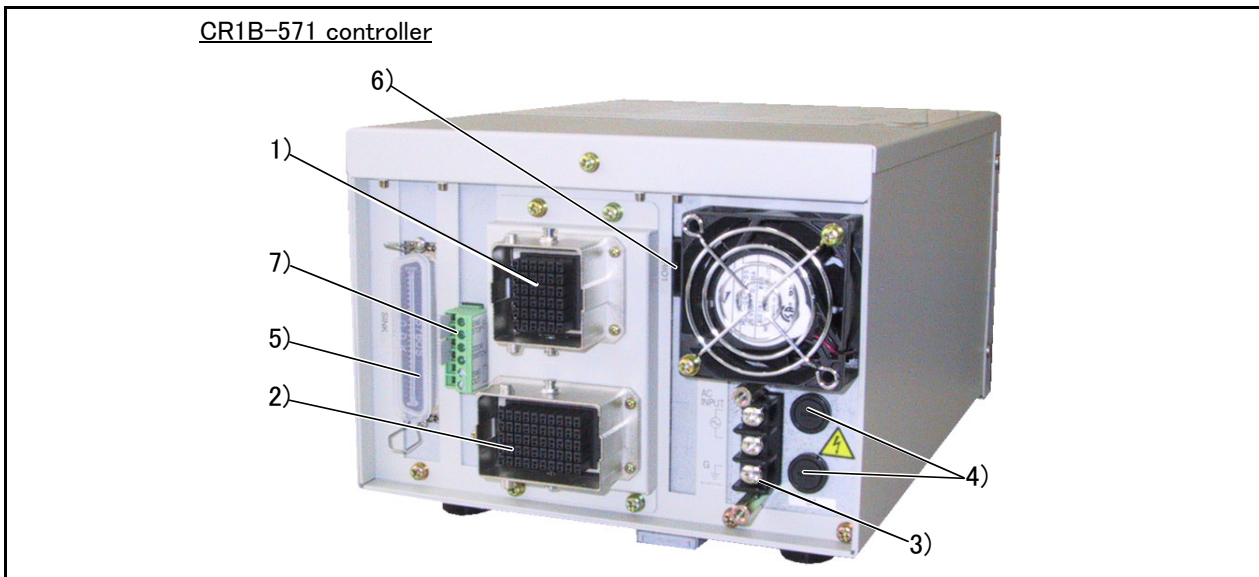

Fig.3-2 : Names of each CR1B-571 controller part (Rear side)

- 1) Machine cable connector (for motor power).....Connects to the robot arm base. (CN1 connector)
- 2) Machine cable connector (for motor signal).....Connects to the robot arm base. (CN2 connector)
- 3)Power supply terminals.
- 4)Fuse box.
- 5)External input/output signal connector.
- 6)Network cable connector for parallel I/O unit expansion.
- 7)Emergency stop switch and door switch terminals connector.

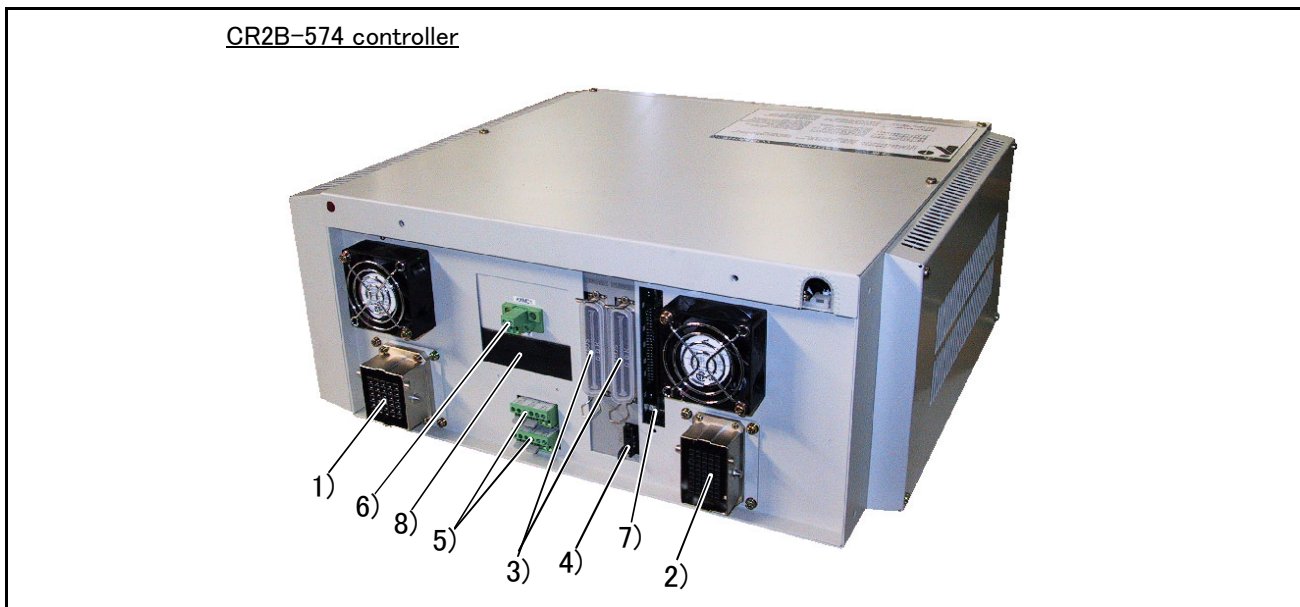

Fig.3-3 : Names of each CR2B-574 controller part (Rear side)

- 1) Machine cable connector (for motor power).....Connects to the robot arm base. (CN1 connector)
- 2) Machine cable connector (for motor signal).....Connects to the robot arm base. (CN2 connector)
- 3) External input/output signal connector.
- 4) Network cable connector for parallel I/O unit expansion.
- 5) Emergency stop switch and door switch terminals.
- 6) Magnet contactor control connector for additional axis (AXMC1)
- 7) Memory cassette entry
- 8) Optional cable inlet

3.3 Outside dimensions/Installation dimensions

3.3.1 Outside dimensions

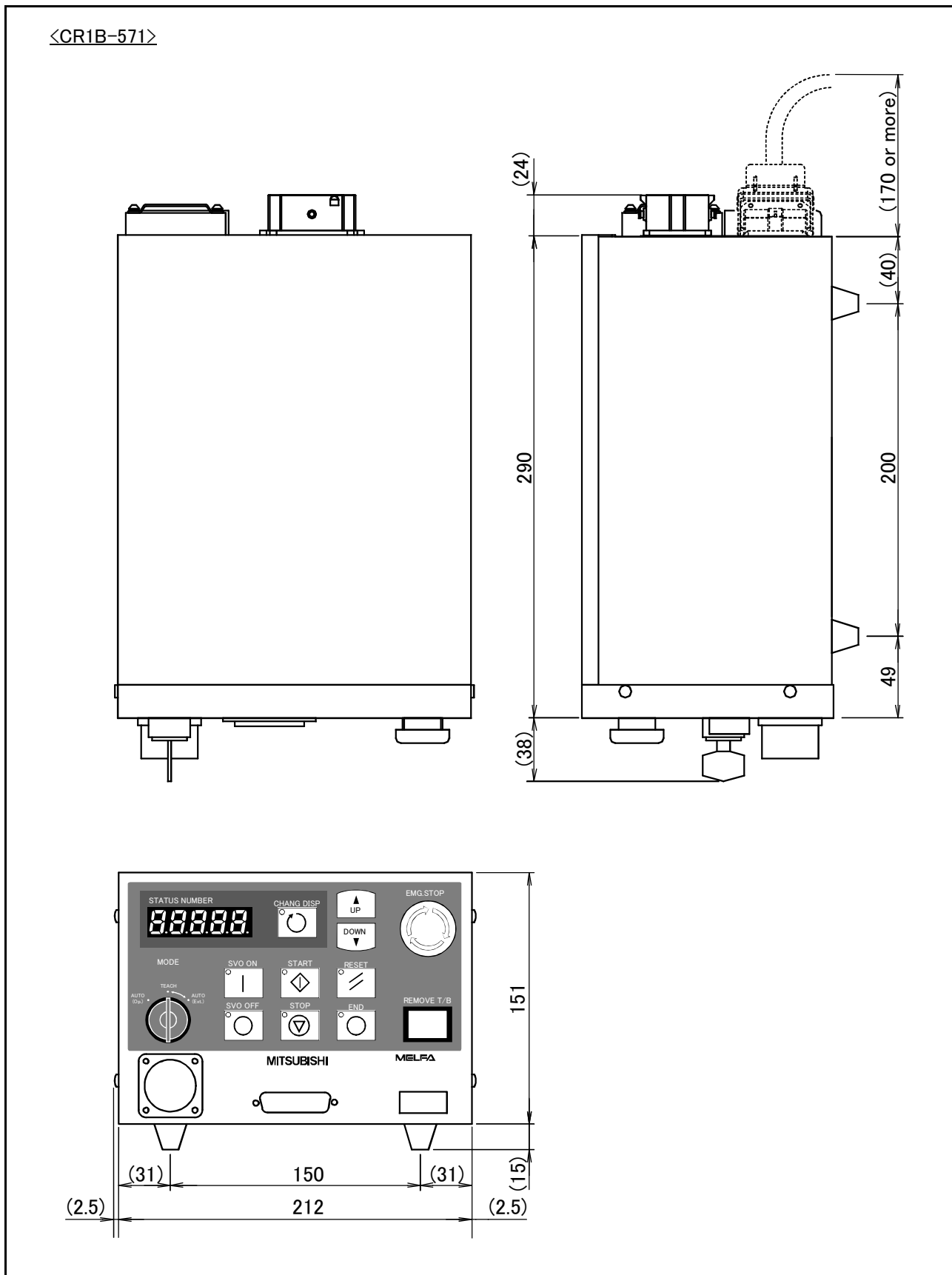

Fig.3-4 : Outside dimensions of controller (CR1B-571 controller)

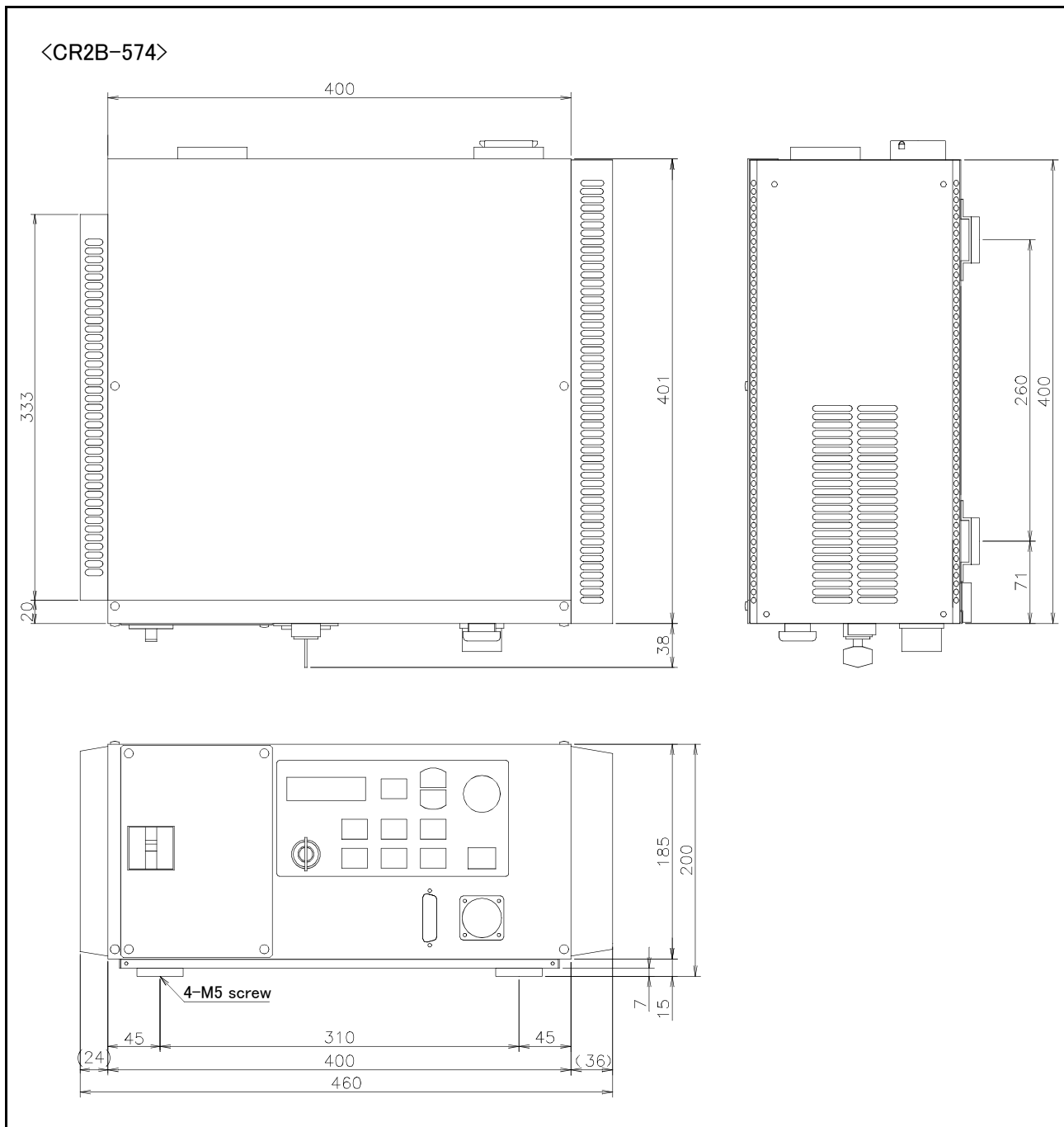

Fig.3-5 : Outside dimensions of controller (CR2B-574 controller)

3.3.2 Installation dimensions

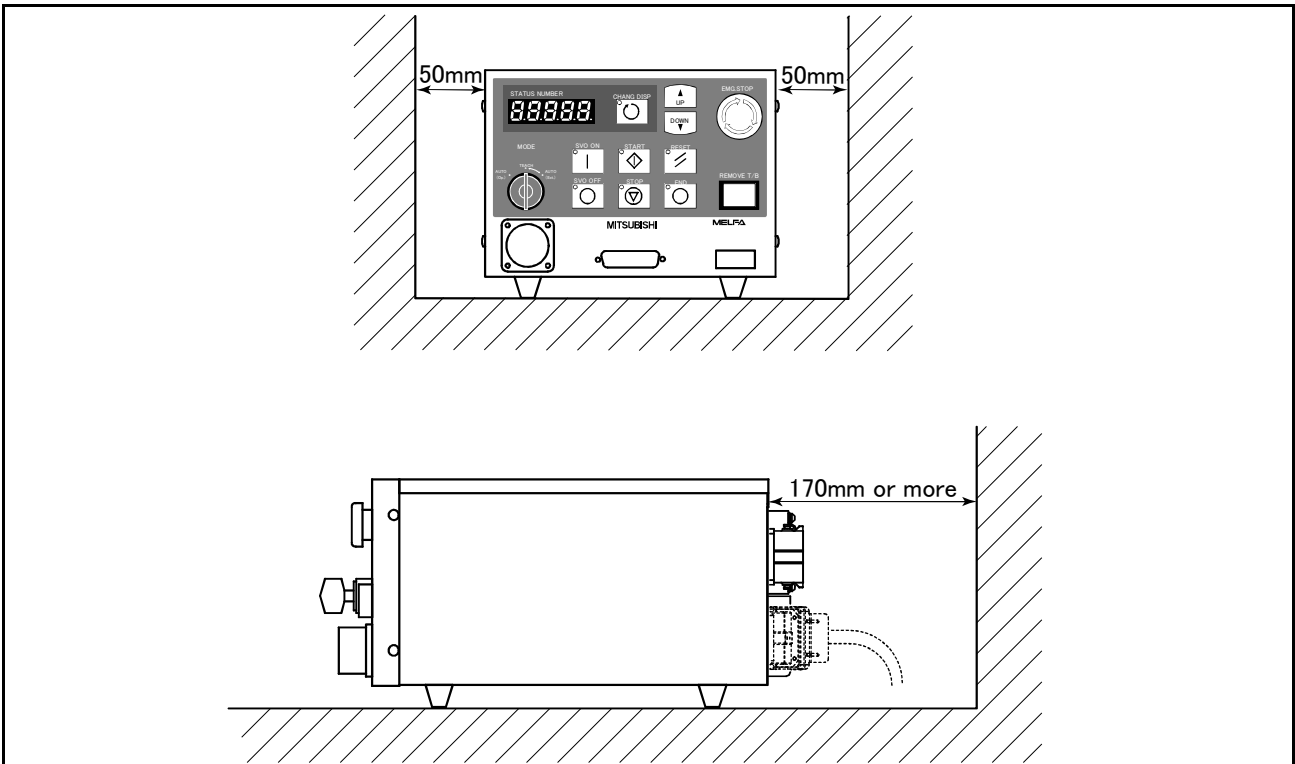

Fig.3-6 : Installation of controller (CR1B-571 controller)

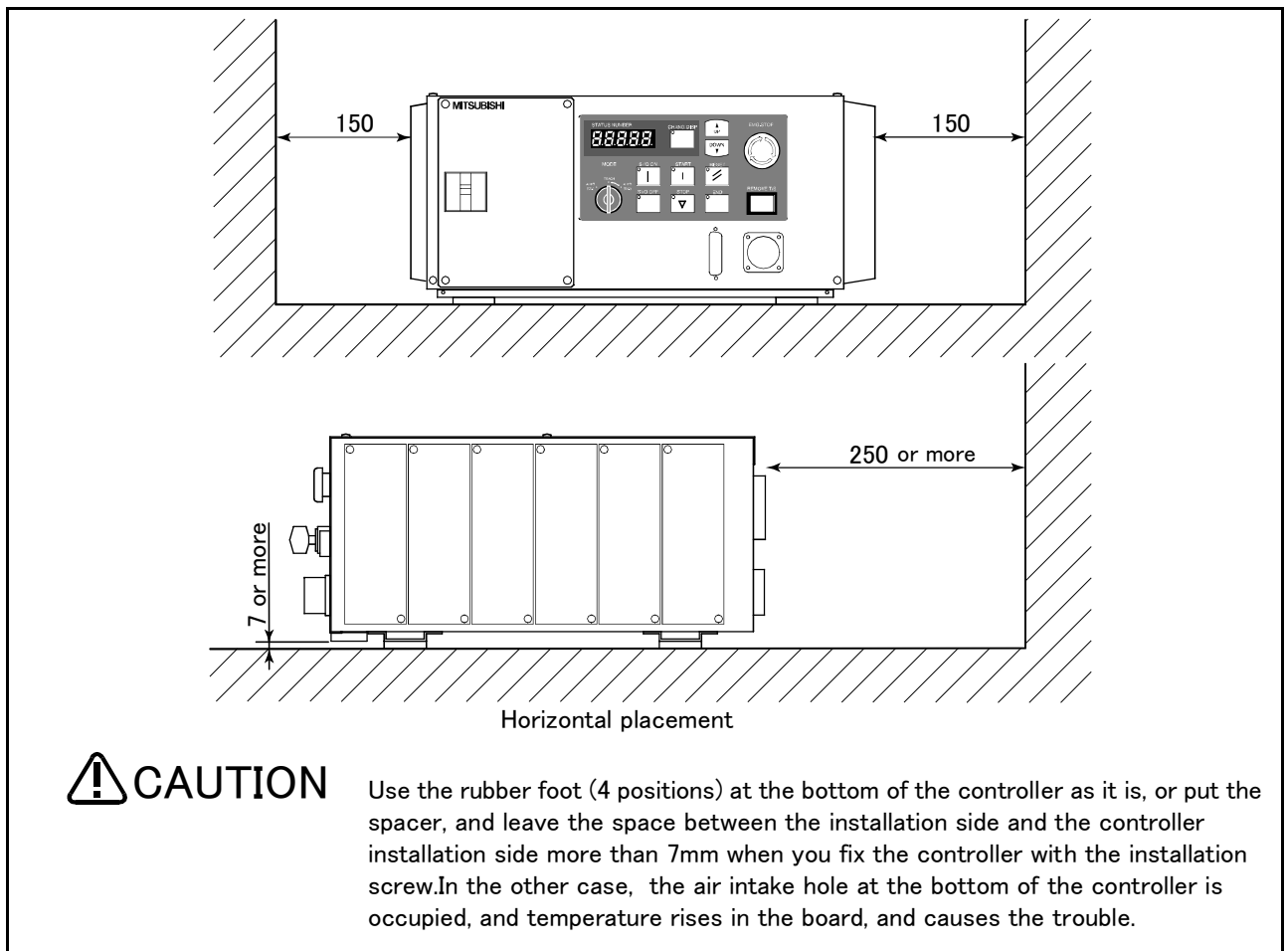

Fig.3-7 : Installation of controller (CR2B-574 controller)

3.4 External input/output

3.4.1 Types

- (1) Dedicated input/output..... These inputs and outputs carry out the robot remote operation and status display.
- (2) General-purpose input/output..... These are inputs and outputs that the customer can program for peripheral device control.
- (3) Hand input/output..... These are inputs and outputs related to the hand that the customer can program. (The hand output is an option. The [Page 64, “\(2\) Pneumatic hand interface”](#) is required.)

Class	Name		No. of input/output points		Connection format
			Input	Output	
Standard	Emergency stop		1	1	Connector
Standard	Door switch		1	-	
Standard	Parallel input/output	CR1B-571 controller	Occupies 16 general-purpose points/(6) dedicated points in general-purpose	Occupies 16 general-purpose points/(4) dedicated points in general-purpose	
		CR2B-574 controller	Occupies 32 general-purpose points/(6) dedicated points in general-purpose	Occupies 32 general-purpose points/(4) dedicated points in general-purpose	

3.4.2 Explanation

The parallel input/output unit uses connector bridging. Purchase the “External I/O cable” for connection with external devices.

The hand output is an option. Refer to [Page 64, “\(2\) Pneumatic hand interface”](#) for details

The parallel input/output unit can be expanded outside of the controller.

The expansion parallel input/output unit is connected with the control unit in the controller using a robot I/O link cable. Parallel input and output units can be expanded as an option to seven maximums. Adding parallel input/output units in this way allows using up to 240 input points and 240 output points, including the 16 input and 16 output general-purpose points in the case of CR1B-571 controller, and up to 256 input points and 256 output points, including the 32 input and 32 output general-purpose points in the case of the CR2B-574 controller.

Refer to [Page 72, “\(5\) Parallel I/O unit”](#) for details on the parallel input/output unit.

3.5 Dedicated input/output

Show the main function of dedicated input/output in the [Table 3-3](#). Refer to attached instruction manual "Detailed explanations of functions and operations" in the product for the other functions. Each parameter indicated with the parameter name is used by designated the signal No., assigned in the order of input signal No. and output signal No. If the number of dedicated inputs and general-purpose input points used exceeds the standard No. of input/output points, install the parallel input/output unit (1st to 7th station: option).

Table 3-3 : Dedicated input/output list

Parameter name	Input <small>Note1)</small>			Output	
	Name	Function	Level	Name	Function
TEACHMD	None			Teaching mode output signal	Outputs that the teaching mode is entered.
ATOPMD	None			Automatic mode output signal	Outputs that the automatic mode is entered.
ATEXTMD	None			Remote mode output signal	Outputs that the remote mode is entered.
RCREADY	None			Controller power ON complete signal	Outputs that external input signals can be received.
AUTOENA	Automatic operation enabled input signal	Allows automatic operation.	L	Automatic operation enabled output signal	Outputs the automatic operation enabled state.
START	Start input signal	Starts all slots.	E	Operating output signal	Outputs that the slot is operating.
STOP	Stop input signal	Stops all slots. The input signal No. is fixed to 0. Note) Use the emergency stop input for stop inputs related to safety.	L	Wait output signal	Outputs that the slot is temporarily stopped.
SLOTINIT	Program reset input signal	Resets the wait state.	E	Program selection enabled output signal	Outputs that the slot is in the program selection enabled state.
ERRRESET	Error reset input signal	Resets the error state.	E	Error occurring output signal	Outputs that an error has occurred.
CYCLE	Cycle stop input signal	Carries out cycle stop.	E	In cycle stop operation output signal	Outputs that the cycle stop is operating.
SRVOFF	Servo ON enabled input signal	Sets all mechanisms to servo ON enabled.	L	Servo ON enabled output signal	Outputs servo-on disable status. (Echo back)
SRVON	Servo ON input signal	Turns the servo ON for all mechanisms.	E	In servo ON output signal	Outputs the servo ON state.
IOENA	Operation rights input signal	Requests the operation rights for the external signal control.	L	Operation rights output signal	Outputs the operation rights valid state for the external signal control.
MELOCK	Machine lock input signal	Sets/resets the machine lock state for all mechanisms.	E	In machine lock output signal	Outputs the machine lock state.
SAFEPOS	Evasion point return input signal	Requests the evasion point return operation.	E	In evasion point return output signal	Outputs that the evasion point return is taking place.
OUTRESET	General-purpose output signal reset	Resets the general-purpose output signal.	E	None	
EMGERR	None			Emergency stop output signal	Outputs that an emergency stop has occurred.
S1START : S32START	Start input	Starts each slot.	E	In operation output	Outputs the operating state for each slot.
S1STOP : S32STOP	Stop input	Stops each slot.	L	In wait output	Outputs that each slot is temporarily stopped.
PRGSEL	Program selection input signal	Designates the setting value for the program No. with numeric value input signals.	E	None	
OVRDSEL	Override selection input signal	Designates the setting value for the override with the numeric value input signals.	E	None	

Parameter name	Input Note1)			Output	
	Name	Function	Level	Name	Function
IODATA Note2)	Numeric value input (start No., end No.)	Used to designate the program name, override value., mechanism value.	L	Numeric value output (start No., end No.)	Used to output the program name, override value., mechanism No.
PRGOUT	Program No. output request	Requests output of the program name.	E	Program No. output signal	Outputs that the program name is being output to the numeric value output signal.
LINEOUT	Line No. output request	Requests output of the line No.	E	Line No. output signal	Outputs that the line No. is being output to the numeric value output signal.
OVRDOUT	Override value output request	Requests the override output.	E	Override value output signal	Outputs that the override value is being output to the numeric value output signal.
ERROUT	Error No. output request	Requests the error No. output.	E	Error No. output signal	Outputs that the error No. is being output to the numeric value output signal.
JOGENA	Jog valid input signal	Validates jog operation with the external signals	E	Jog valid output signal	Outputs that the jog operation with external signals is valid.
JOGM	Jog mode input 2-bit	Designates the jog mode.	L	Jog mode output 2-bit	Outputs the current jog mode.
JOG+	Jog feed + side for 8-axes	Requests the + side jog operation.	L	None	
JOG-	Jog feed - side for 8-axes	Requests the - side jog operation.	L	None	
HNDCTRL1 : HNDCTRL3	None			Mechanism 1 hand output signal status : Mechanism 3 hand output signal status	Mechanism 1: Outputs the status of general-purpose outputs 900 to 907. Mechanism 2: Outputs the status of general-purpose outputs 910 to 917. Mechanism 3: Outputs the status of general-purpose outputs 920 to 927.
HNDSTS1 : HNDSTS3	None			Mechanism 1 hand input signal status : Mechanism 3 hand input signal status	Mechanism 1: Outputs the status of hand inputs 900 to 907. Mechanism 2: Outputs the status of hand inputs 910 to 917. Mechanism 3: Outputs the status of hand inputs 920 to 927.
HNDERR1 : HNDERR3	Mechanism 1 hand error input signal : Mechanism 3 hand error input signal	Requests the hand error occurrence.	L	Mechanism 1 hand error output signal : Mechanism 3 hand error output signal	Outputs that a hand error is occurring.
AIRERR1 : AIRERR3	Pneumatic pressure error 1 input signal : Pneumatic pressure error 3 input signal	Request the pneumatic pressure error occurrence.	L	Pneumatic pressure error 1 output signal. : Pneumatic pressure error 3 output signal.	Outputs that a pneumatic pressure error is occurring.
M1PTEXC : M3PTEXC	None		L	Maintenance parts replacement time warning signal	Outputs that the maintenance parts have reached the replacement time.
USER-AREA Note3)	None			User-designated area 8-points	Outputs that the robot is in the user-designated area.

Note1) The level indicates the signal level.

L: Level signal → The designated function is validated when the signal is ON, and is invalidated when the signal is OFF.

E: Edge signal → The designated function is validated when the signal changes from the OFF to ON state, and the function maintains the original state even when the signal then turns OFF.

Note2) Four elements are set in the order of input signal start No., end No., output signal start No. and end No.

Note3) Up to eight points can be set successively in order of start output signal No. and end output signal No.

3.6 Emergency stop input/output

This signal is input from the "emergency stop input" terminal in the controller.

Table 3-4 : Dedicated input terminals in controller

Class	Name	Details
Input	Emergency stop	Applies the emergency stop (CR1B-571:Single emergency line, CR2B-574: Dual emergency line.)
Input	Door switch	The servo turns OFF.
Output	Emergency stop	CR1B-571:This output indicates that the emergency stop input or the door switch input is turned on. CR2B-574:This output indicates that the emergency stop is being input.

3.6.1 Connection of the external emergency stop

The external emergency stop input and door switch input are short-circuited with a short cable at shipment as shown in Fig. 3-8.

Connect the external emergency stop switch and door switch with the following procedure.

- 1) Prepare the "emergency stop switch" and "door switch".
- 2) Remove the short pieces 1 and 2.
- 3) Securely connect the external emergency stop's contacts across "1)-2)", and the door switch's contacts across 3)-4)" on the terminal block.

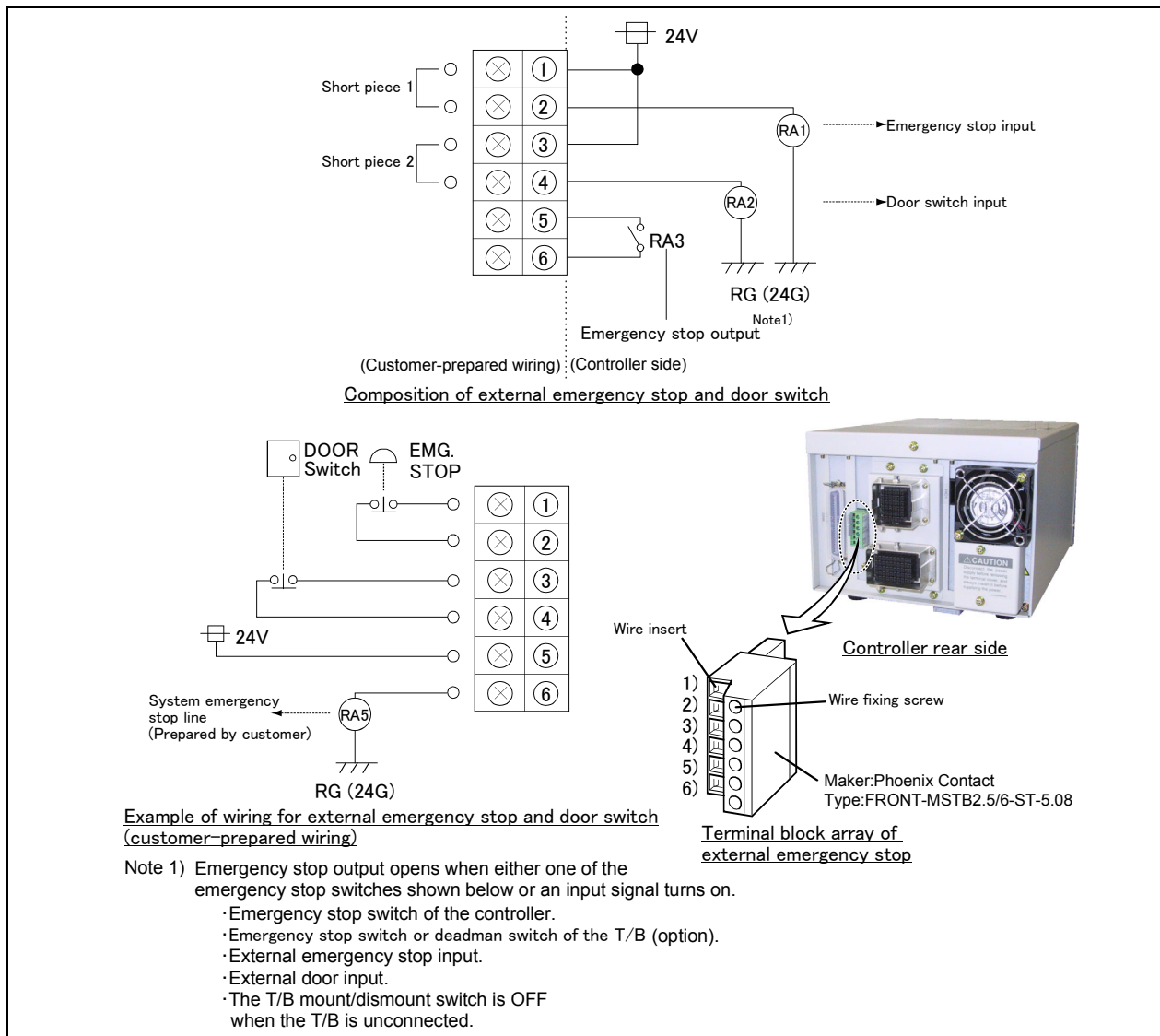

Fig.3-8 : Connection of the external emergency stop (CR1B-571 controller)

[Caution] When wiring the emergency stop switch (duble emergency line type), wire both contacts to the two terminal blocks on the controller. If both contacts are wired to only one of the terminal blocks, errors cannot be cancelled using the door switch.

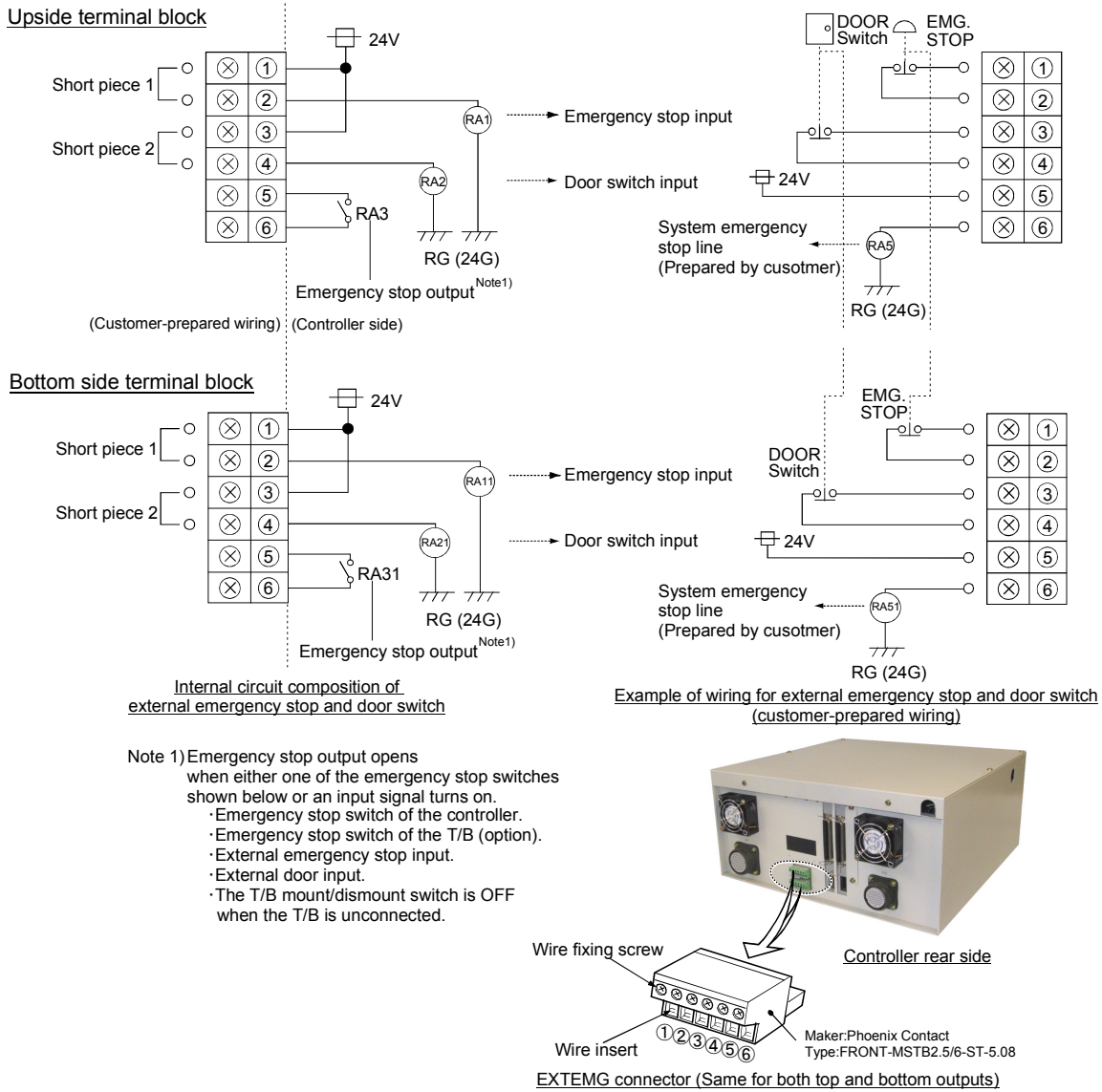

Fig.3-9 : Connection of the external emergency stop (CR2B-574 controller)

[Note] Refer to Page 110, "6.1.7 Examples of safety measures" together, and carry out wiring to the emergency stop.

3.6.2 Door switch function

This function retrieves the status of the switch installed on the door of the safety fence, etc., and stops the robot when the door is opened. This differs from an emergency stop in that the servo turns OFF when the door is opened and an error does not occur. Follow the wiring example shown in Fig. 3-8, and wire so that the contact closes when the door is closed. Details of this function according to the robot status are shown below.

- During automatic operationWhen the door is opened, the servo turns OFF and the robot stops. An error occurs.
The process of the restoration : Close the door, reset the alarm, turn on the servo, and restart
- During teaching.....Even when the door is opened, the servo can be turned ON and the robot moved using the teaching pendant.

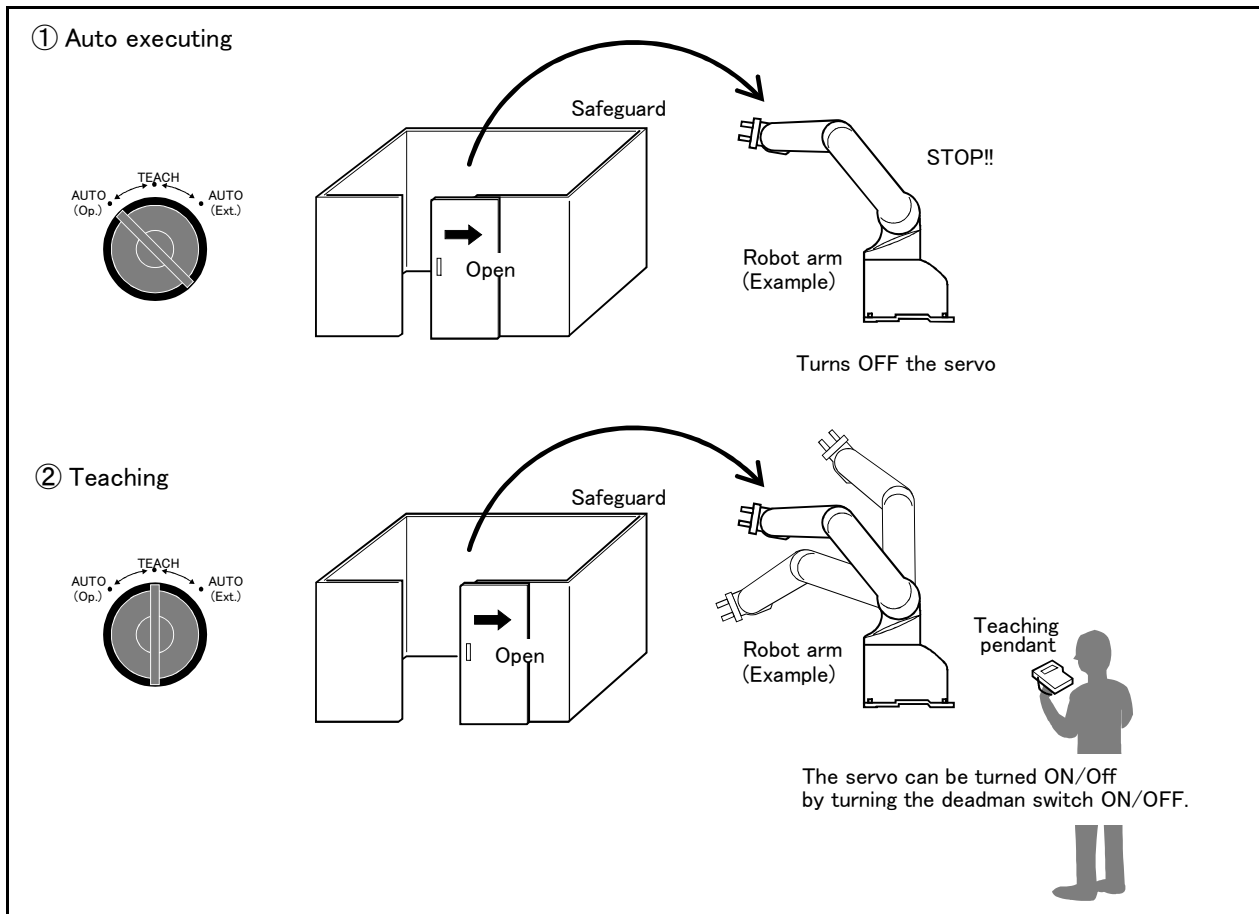

Fig.3-10 : Door switch function

3.7 Parallel input/output unit

- A parallel input/output card is mounted as a standard in the controller's control unit.
- The external input/output circuit specifications are shown in [Table 3-5](#) and [Table 3-6](#).
- The pin numbers of external input/output connectors and the corresponding line colors of the connected optional "external I/O cables" are explained in "(1)Pin numbers of standard parallel input/output cards and signal assignment(CR1B-571)" and "(2)Pin numbers of standard parallel input/output cards and signal assignment(CR2B-574)". Refer to [Page 82](#), "(6) External I/O cable" for details of external I/O cable.
- Pin Nos. described as both general-purpose signal and dedicated signal can be shared.
- The other dedicated input/output signals that are not assigned can be assigned to required general-purpose input/output pins when creating the program.
- If the standard inputs and outputs are insufficient, install the parallel input/output unit connection option outside the controller.

Table 3-5 : Electrical specifications of input circuit

Item	Specifications	Internal circuit	
Type	DC input	<p><Sink type></p>  <p><Source type></p> 	
No. of input points	CR1B-571: 16, CR2B-574: 32		
Insulation method	Photo-coupler insulation		
Rated input voltage	12VDC/24VDC		
Rated input current	Approx. 3mA/approx. 7mA		
Working voltage range	10.2VDC to 26.4VDC(ripple rate within 5%)		
ON voltage/ON current	8VDC or more/2mA or more		
OFF voltage/OFF current	4VDC or less/1mA or less		
Input resistance	Approx. 3.3kΩ		
Response time	OFF-ON 10ms or less(DC24V) ON-OFF 10ms or less(DC24V)		
Common method	8 points per common		
External wire connection method	Connector		

Table 3-6 : Electrical specifications of output circuit

Item	Specifications	Internal circuit
Type	Transistor output	<p><Sink type></p>  <p><Source type></p> 
No. of output points	CR1B-571: 16, CR2B-574: 32	
Insulation method	Photo-coupler insulation	
Rated load voltage	DC12V/DC24V	
Rated load voltage range	DC10.2 ~ 30V(peak voltage 30VDC)	
Max. load current	0.1A/point (100%)	
Leakage current at OFF	0.1mA or less	
Max. voltage drop at ON	DC0.9V(TYP.)	
Response time	OFF-ON 2ms or less (hardware response time) ON-OFF 2ms or less (Resistance load) (hardware response time)	
Fuse rating	Fuse 3.2A (one per common) Replacement not possible	
Common method	4 points per common (common terminal: 4 points)	
External wire connection method	Connector	
External power supply	Voltage DC12/24V(DC10.2 ~ 30V) Current 60mA (TYP. 24VDC per common) (base drive current)	

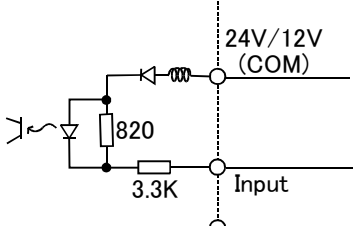
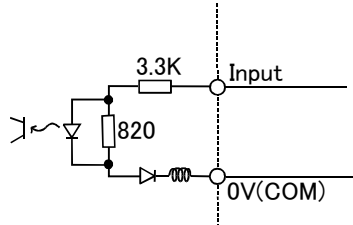
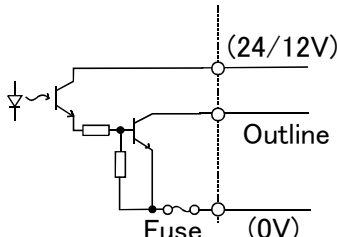
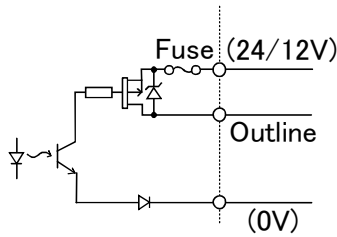
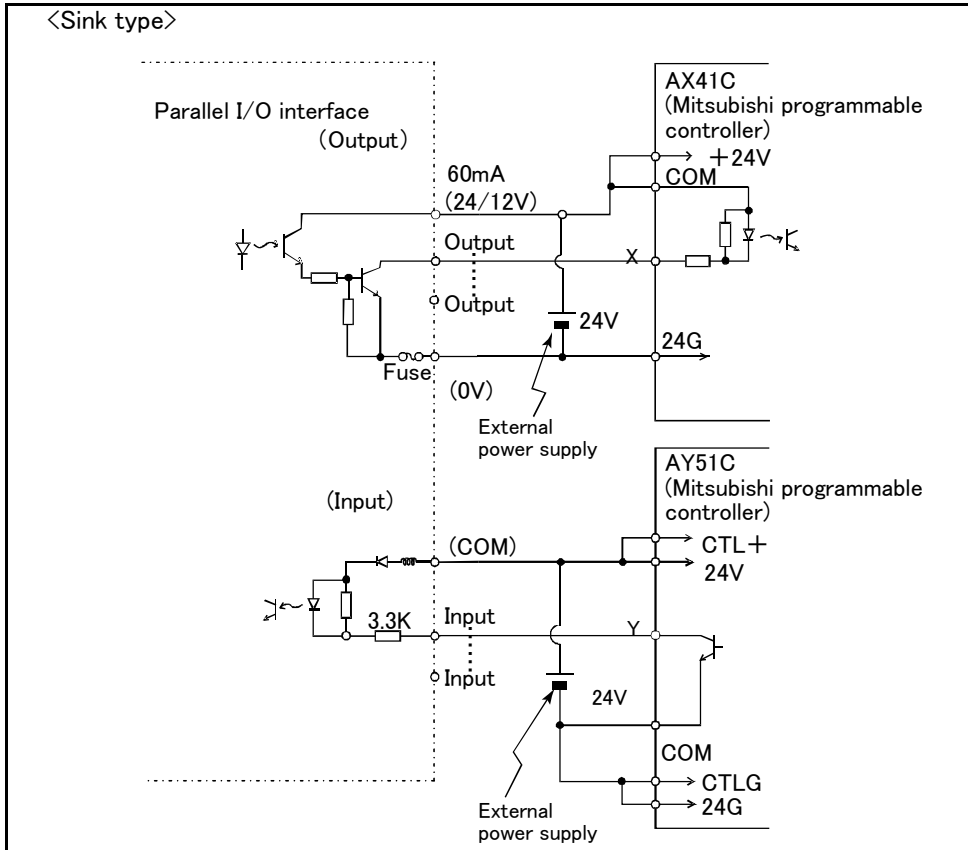

Fig.3-11 : Connection with a Mitsubishi PLC (Example of sink type)

*The input/output circuit external power supply (24 VDC) must be prepared by the customer.

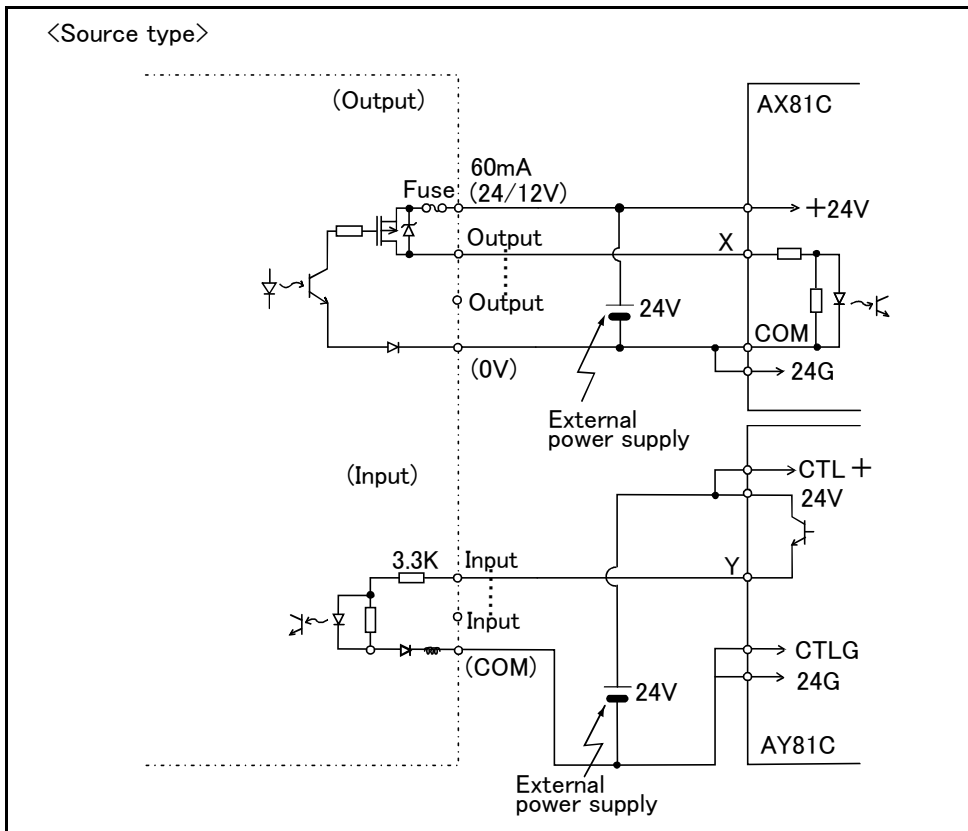

Fig.3-12 : Connection with a Mitsubishi PLC (Example of source type)

*The input/output circuit external power supply (24 VDC) must be prepared by the customer.

(1) Pin numbers of standard parallel input/output cards and signal assignment(CR1B-571)

Table 3-7 : Standard parallel I/O interface CN100pin No. and signal assignment list <Sink type> (2A-CBL □□)

Pin No.	Line color	Function name		Pin No.	Line color	Function name	
		General-purpose	Dedicated/power supply, common			General-purpose	Dedicated/power supply, common
1	Orange/Red A		FG	26	Orange/Blue A		FG
2	Gray/Red A		0V:For pins 4-7	27	Gray/Blue A		0V:For pins 29-32
3	White/Red A		12V/24V:For pins 4-7	28	White/Blue A		12V/24V:For pins 29-32
4	Yellow/Red A	General-purpose output 0	Running	29	Yellow/Blue A	General-purpose output 4	
5	Pink/Red A	General-purpose output 1	Servo on	30	Pink/Blue A	General-purpose output 5	
6	Orange/Red B	General-purpose output 2	Error	31	Orange/Blue B	General-purpose output 6	
7	Gray/Red B	General-purpose output 3	Operation rights	32	Gray/Blue B	General-purpose output 7	
8	White/Red B		0V:For pins 10-13	33	White/Blue B		0V:For pins 35-38
9	Yellow/Red B		12V/24V:For pins 10-13	34	Yellow/Blue B		12V/24V:For pins 35-38
10	Pink/Red B	General-purpose output 8		35	Pink/Blue B	General-purpose output 12	
11	Orange/Red C	General-purpose output 9		36	Orange/Blue C	General-purpose output 13	
12	Gray/Red C	General-purpose output 10		37	Gray/Blue C	General-purpose output 14	
13	White/Red C	General-purpose output 11		38	White/Blue C	General-purpose output 15	
14	Yellow/Red C		COM0:For pins 15-22 ^{Note1)}	39	Yellow/Blue C		COM1:For pins 40-47 ^{Note1)}
15	Pink/Red C	General-purpose input 0	Stop(All slot) ^{Note2)}	40	Pink/Blue C	General-purpose input 8	
16	Orange/Red D	General-purpose input 1	Servo off	41	Orange/Blue D	General-purpose input 9	
17	Gray/Red D	General-purpose input 2	Error reset	42	Gray/Blue D	General-purpose input 10	
18	White/Red D	General-purpose input 3	Start	43	White/Blue D	General-purpose input 11	
19	Yellow/Red D	General-purpose input 4	Servo on	44	Yellow/Blue D	General-purpose input 12	
20	Pink/Red D	General-purpose input 5	Operation rights	45	Pink/Blue D	General-purpose input 13	
21	Orange/Red E	General-purpose input 6		46	Orange/Blue E	General-purpose input 14	
22	Gray/Red E	General-purpose input 7		47	Gray/Blue E	General-purpose input 15	
23	White/Red E		Reserved	48	White/Blue E		Reserved
24	Yellow/Red E		Reserved	49	Yellow/Blue E		Reserved
25	Pink/Red E		Reserved	50	Pink/Blue E		Reserved

Note1)Sink type:24V/12V(COM), Source type:0V(COM)

Note2)The assignment of the dedicated input signal "STOP" is fixed.

Table 3-8 : Standard parallel I/O interface CN100pin No. and signal assignment list <Source type> (2A-CBL □□)

Pin No.	Line color	Function name		Pin No.	Line color	Function name	
		General-purpose	Dedicated/power supply, common			General-purpose	Dedicated/power supply, common
1	Orange/Red A		FG	26	Orange/Blue A		FG
2	Gray/Red A		0V:For pins 4-7, 10-13	27	Gray/Blue A		0V:For pins 29-32, 35-38
3	White/Red A		12V/24V:For pins 4-7, 10-13	28	White/Blue A		12V/24V:For pins 29-32, 35-38
4	Yellow/Red A	General-purpose output 0	Running	29	Yellow/Blue A	General-purpose output 4	
5	Pink/Red A	General-purpose output 1	Servo on	30	Pink/Blue A	General-purpose output 5	
6	Orange/Red B	General-purpose output 2	Error	31	Orange/Blue B	General-purpose output 6	
7	Gray/Red B	General-purpose output 3	Operation rights	32	Gray/Blue B	General-purpose output 7	
8	White/Red B		Reserved	33	White/Blue B		Reserved
9	Yellow/Red B		Reserved	34	Yellow/Blue B		Reserved
10	Pink/Red B	General-purpose output 8		35	Pink/Blue B	General-purpose output 12	
11	Orange/Red C	General-purpose output 9		36	Orange/Blue C	General-purpose output 13	
12	Gray/Red C	General-purpose output 10		37	Gray/Blue C	General-purpose output 14	
13	White/Red C	General-purpose output 11		38	White/Blue C	General-purpose output 15	
14	Yellow/Red C		COM0:For pins 15-22 ^{Note1)}	39	Yellow/Blue C		COM1:For pins 40-47 ^{Note1)}
15	Pink/Red C	General-purpose input 0	Stop(All slot) ^{Note2)}	40	Pink/Blue C	General-purpose input 8	
16	Orange/Red D	General-purpose input 1	Servo off	41	Orange/Blue D	General-purpose input 9	
17	Gray/Red D	General-purpose input 2	Error reset	42	Gray/Blue D	General-purpose input 10	
18	White/Red D	General-purpose input 3	Start	43	White/Blue D	General-purpose input 11	
19	Yellow/Red D	General-purpose input 4	Servo on	44	Yellow/Blue D	General-purpose input 12	
20	Pink/Red D	General-purpose input 5	Operation rights	45	Pink/Blue D	General-purpose input 13	
21	Orange/Red E	General-purpose input 6		46	Orange/Blue E	General-purpose input 14	
22	Gray/Red E	General-purpose input 7		47	Gray/Blue E	General-purpose input 15	
23	White/Red E		Reserved	48	White/Blue E		Reserved
24	Yellow/Red E		Reserved	49	Yellow/Blue E		Reserved
25	Pink/Red E		Reserved	50	Pink/Blue E		Reserved

Note1)Sink type:24V/12V(COM), Source type:0V(COM)

Note2)The assignment of the dedicated input signal "STOP" is fixed.

(2) Pin numbers of standard parallel input/output cards and signal assignment(CR2B-574)

Table 3-9 : Standard parallel I/O interface CN100pin No. and signal assignment list (2A-CBL □□)

Pin No.	Line color	Function name		Pin No.	Line color	Function name	
		General-purpose	Dedicated/power supply, common			General-purpose	Dedicated/power supply, common
1	Orange/Red A		FG	26	Orange/Blue A		FG
2	Gray/Red A		0V:For pins 4-7	27	Gray/Blue A		0V:For pins 29-32
3	White/Red A		12V/24V:For pins 4-7	28	White/Blue A		12V/24V:For pins 29-32
4	Yellow/Red A	General-purpose output 0	Running	29	Yellow/Blue A	General-purpose output 4	
5	Pink/Red A	General-purpose output 1	Servo on	30	Pink/Blue A	General-purpose output 5	
6	Orange/Red B	General-purpose output 2	Error	31	Orange/Blue B	General-purpose output 6	
7	Gray/Red B	General-purpose output 3	Operation rights	32	Gray/Blue B	General-purpose output 7	
8	White/Red B		0V:For pins 10-13	33	White/Blue B		0V:For pins 35-38
9	Yellow/Red B		12V/24V:For pins 10-13	34	Yellow/Blue B		12V/24V:For pins 35-38
10	Pink/Red B	General-purpose output 8		35	Pink/Blue B	General-purpose output 12	
11	Orange/Red C	General-purpose output 9		36	Orange/Blue C	General-purpose output 13	
12	Gray/Red C	General-purpose output 10		37	Gray/Blue C	General-purpose output 14	
13	White/Red C	General-purpose output 11		38	White/Blue C	General-purpose output 15	
14	Yellow/Red C		COM0:For pins 15-22 ^{Note1)}	39	Yellow/Blue C		COM1:For pins 40-47 ^{Note1)}
15	Pink/Red C	General-purpose input 0	Stop(All slot) ^{Note2)}	40	Pink/Blue C	General-purpose input 8	
16	Orange/Red D	General-purpose input 1	Servo off	41	Orange/Blue D	General-purpose input 9	
17	Gray/Red D	General-purpose input 2	Error reset	42	Gray/Blue D	General-purpose input 10	
18	White/Red D	General-purpose input 3	Start	43	White/Blue D	General-purpose input 11	
19	Yellow/Red D	General-purpose input 4	Servo on	44	Yellow/Blue D	General-purpose input 12	
20	Pink/Red D	General-purpose input 5	Operation rights	45	Pink/Blue D	General-purpose input 13	
21	Orange/Red E	General-purpose input 6		46	Orange/Blue E	General-purpose input 14	
22	Gray/Red E	General-purpose input 7		47	Gray/Blue E	General-purpose input 15	
23	White/Red E		Reserved	48	White/Blue E		Reserved
24	Yellow/Red E		Reserved	49	Yellow/Blue E		Reserved
25	Pink/Red E		Reserved	50	Pink/Blue E		Reserved

Note1)Sink type:24V/12V(COM), Source type:0V(COM)

Note2)The assignment of the dedicated input signal "STOP" is fixed.

Table 3-10 : Standard parallel I/O interface CN300pin No. and signal assignment list (2A-CBL □□)

Pin No.	Line color	Function name		Pin No.	Line color	Function name	
		General-purpose	Dedicated/power supply, common			General-purpose	Dedicated/power supply, common
1	Orange/Red A		FG	26	Orange/Blue A		FG
2	Gray/Red A		0V:For pins 4-7	27	Gray/Blue A		0V:For pins 29-32
3	White/Red A		12V/24V:For pins 4-7	28	White/Blue A		12V/24V:For pins 29-32
4	Yellow/Red A	General-purpose output 16		29	Yellow/Blue A	General-purpose output 20	
5	Pink/Red A	General-purpose output 17		30	Pink/Blue A	General-purpose output 21	
6	Orange/Red B	General-purpose output 18		31	Orange/Blue B	General-purpose output 22	
7	Gray/Red B	General-purpose output 19		32	Gray/Blue B	General-purpose output 23	
8	White/Red B		0V:For pins 10-13	33	White/Blue B		0V:For pins 35-38
9	Yellow/Red B		12V/24V:For pins 10-13	34	Yellow/Blue B		12V/24V:For pins 35-38
10	Pink/Red B	General-purpose output 24		35	Pink/Blue B	General-purpose output 28	
11	Orange/Red C	General-purpose output 25		36	Orange/Blue C	General-purpose output 29	
12	Gray/Red C	General-purpose output 26		37	Gray/Blue C	General-purpose output 30	
13	White/Red C	General-purpose output 27		38	White/Blue C	General-purpose output 31	
14	Yellow/Red C		COM0:For pins 15-22 ^{Note1)}	39	Yellow/Blue C		COM1:For pins 40-47 ^{Note1)}
15	Pink/Red C	General-purpose input 16		40	Pink/Blue C	General-purpose input 24	
16	Orange/Red D	General-purpose input 17		41	Orange/Blue D	General-purpose input 25	
17	Gray/Red D	General-purpose input 18		42	Gray/Blue D	General-purpose input 26	
18	White/Red D	General-purpose input 19		43	White/Blue D	General-purpose input 27	
19	Yellow/Red D	General-purpose input 20		44	Yellow/Blue D	General-purpose input 28	
20	Pink/Red D	General-purpose input 21		45	Pink/Blue D	General-purpose input 29	
21	Orange/Red E	General-purpose input 22		46	Orange/Blue E	General-purpose input 30	
22	Gray/Red E	General-purpose input 23		47	Gray/Blue E	General-purpose input 31	
23	White/Red E		Reserved	48	White/Blue E		Reserved
24	Yellow/Red E		Reserved	49	Yellow/Blue E		Reserved
25	Pink/Red E		Reserved	50	Pink/Blue E		Reserved

Note1)Sink type:24V/12V(COM), Source type:0V(COM)

- The signals assigned as dedicated inputs can be used as general-purpose inputs during program execution. Note that for safety proposes, these should not be shared with the general-purpose inputs other than for numeric value inputs. The signals assigned as dedicated outputs cannot be used in the program. An alarm will occur during operation if used.

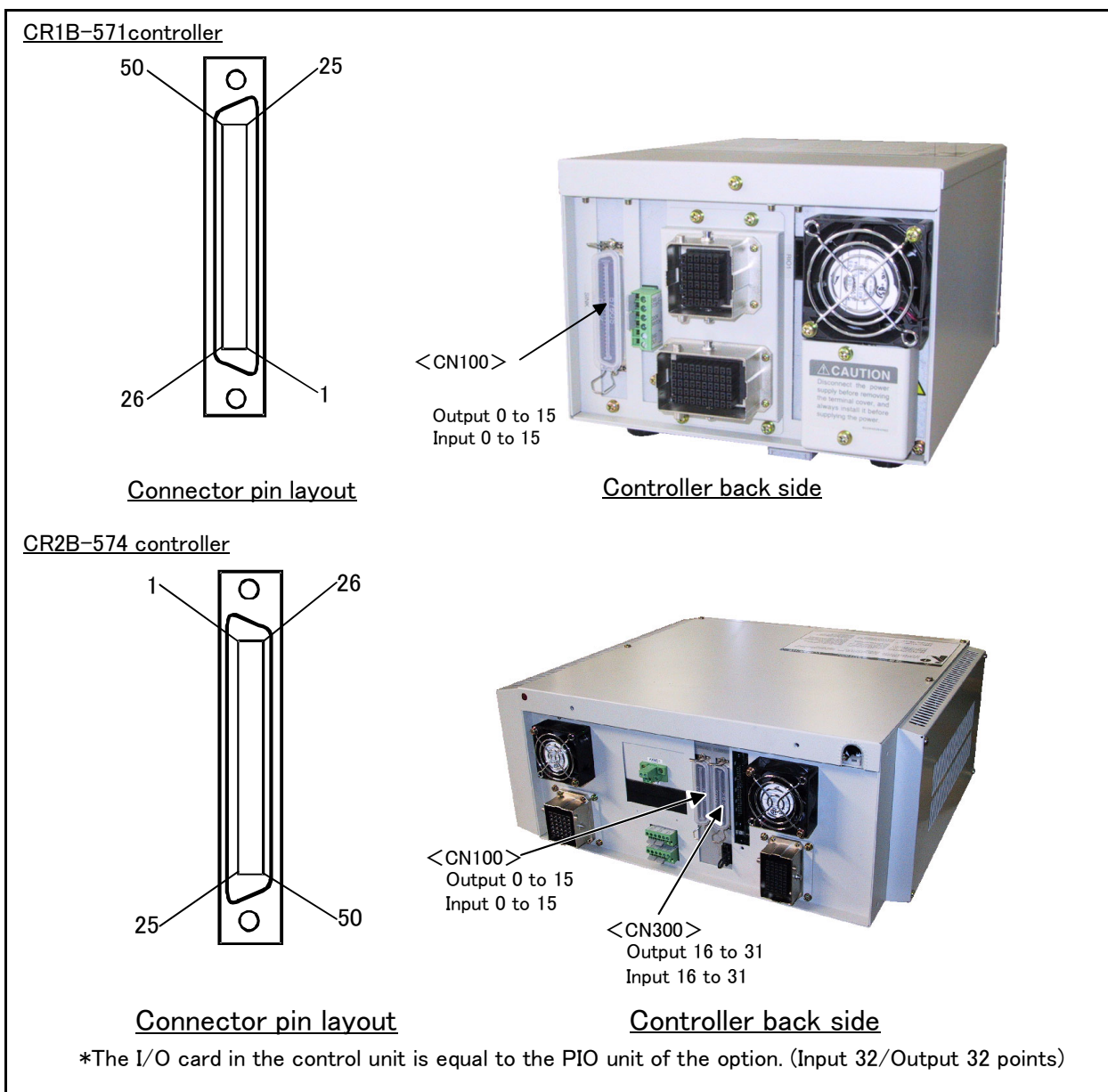

Fig.3-13 : Parallel input/output unit (in the control unit) connection and pin layout

3.8 Options

■ What are options?

There are a variety of options for the robot designed to make the setting up process easier for user needs.

User installation is required for the options.

Options come in two types: "set options" and "single options".

1. Set optionsA combination of single options and parts that together, form a set for serving some purpose.
2. Single optionsThat are configured from the fewest number of required units of a part. Please choose user's purpose additionally.

(1) Teaching pendant (T/B)

- Order type: R28TB :Cable length 7m
R28TB-15 :Cable length 15m

Note) There is a cable length 15m as special specification. Confirm the delivery date.

- Outline



This is used to create, edit and control the program, teach the operation position and for jog feed, etc.

For safety proposes, a 3-position deadman switch is mounted.^{Note1)}

If there are several robots, one teaching pendant can be used by connecting it to the respective robot.

- Configuration

Table 3-11 : Configuration device

Part name	Type	Qty.	Remarks
Teaching pendant	R28TB	Either one pc.	Cable length is 7m. Hand strap is attached.
	R28TB-15		Cable length is 15m. Hand strap is attached.

- Specifications

Table 3-12 : Specifications

Items	Specifications	Remarks
Outline dimensions	153(W) x 203(H) x 70(D) (refer to outline drawing)	
Body color	Light gray (reference Munsell color: 0.08GY7.64/0.81)	
Mass	Approx. 0.8kg (only arm, excluding cable)	
Connection method	Connection with controller and round connector (30-pin)	
Interface	RS-422	
Display method	LCD method: 16 characters x 4 lines, LCD illumination: with backlight	
Operation section	28 keys	
Protection specifications	IP65	Note2)

Note2) The manual operation section of the teaching pendant has a protection method that complies with the IEC Standards IP65 (protection type).

[Reference] IPProtection against water infiltration as specified in IP65 indicates a protective structure that is not harmfully affected when $12.5 \pm 5\%$ liters of water is supplied from a test device at a position approx. 3m away in various directions and a water pressure of 30kPa at the nozzle section. The water is filled one minute per 1m^2 of test device surface area for a total of three minutes.

Note1) <3-position deadman switch>

In ISO/10218 (1992) and JIS-B8433 (1993), this is defined as an "enable device". These standards specify that the robot operation using the teaching pendant is enabled only when the "enable device" is at a specified position. With the Mitsubishi Electric industrial robot, the above "enable device" is configured of an "Enable/Disable switch" and "Deadman switch".

The 3-position deadman switch has three statuses. The following modes are entered according to the switch state.

"Not pressed" The robot does not operate. *)

"Pressed lightly" The robot can be operated and teaching is possible.

"Pressed with force" The robot does not operate. *)

*) Operations, such as program editing and status display, other than robot operation are possible.

Safety is secured as the servo power is turned OFF simultaneously with the input of the emergency stop.

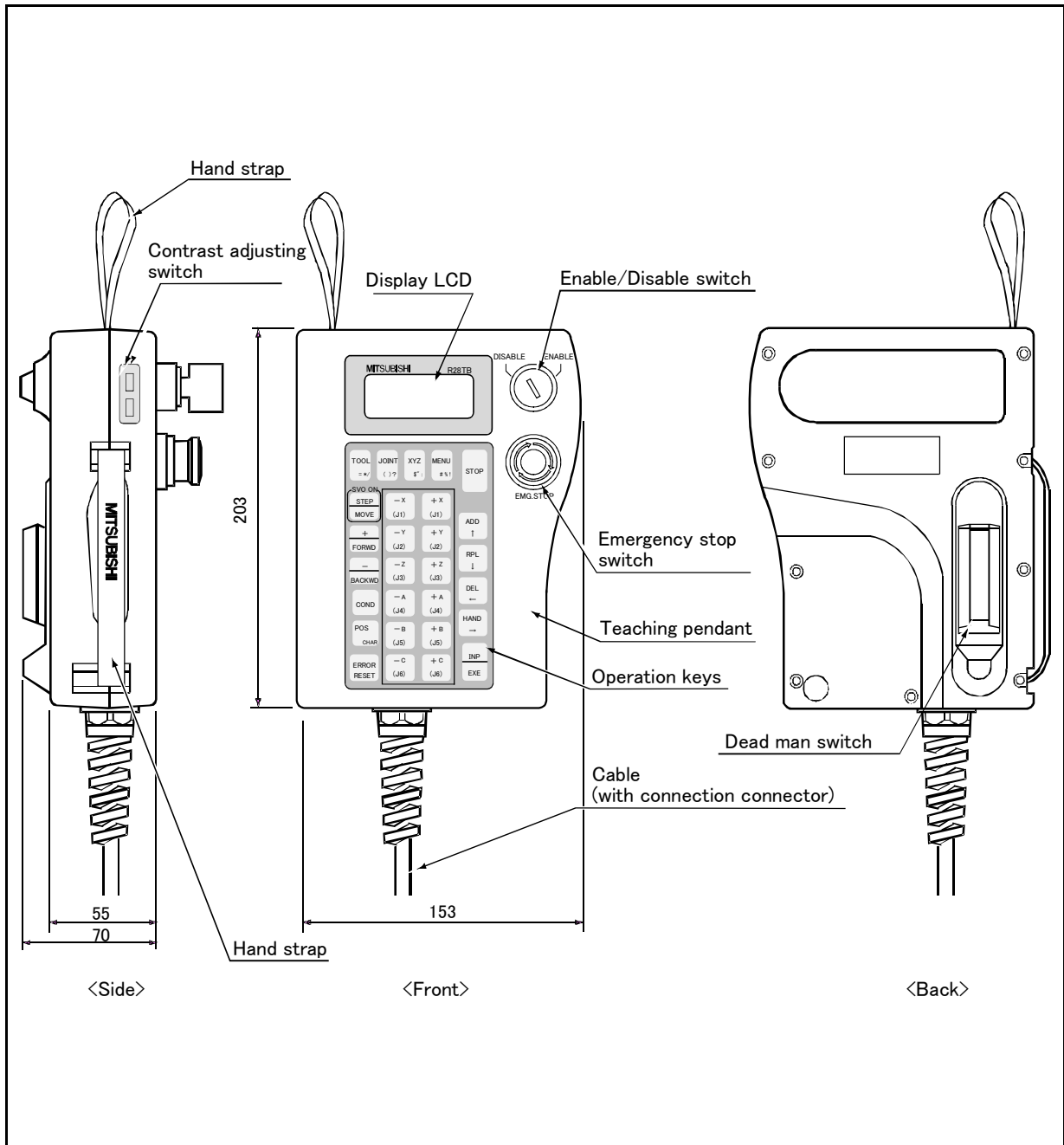

Fig.3-14 : Outside dimensions of teaching pendant

■ Installation method

The teaching pendant is connected to the T/B connector on the front of the controller.

■ Key layout and main functions

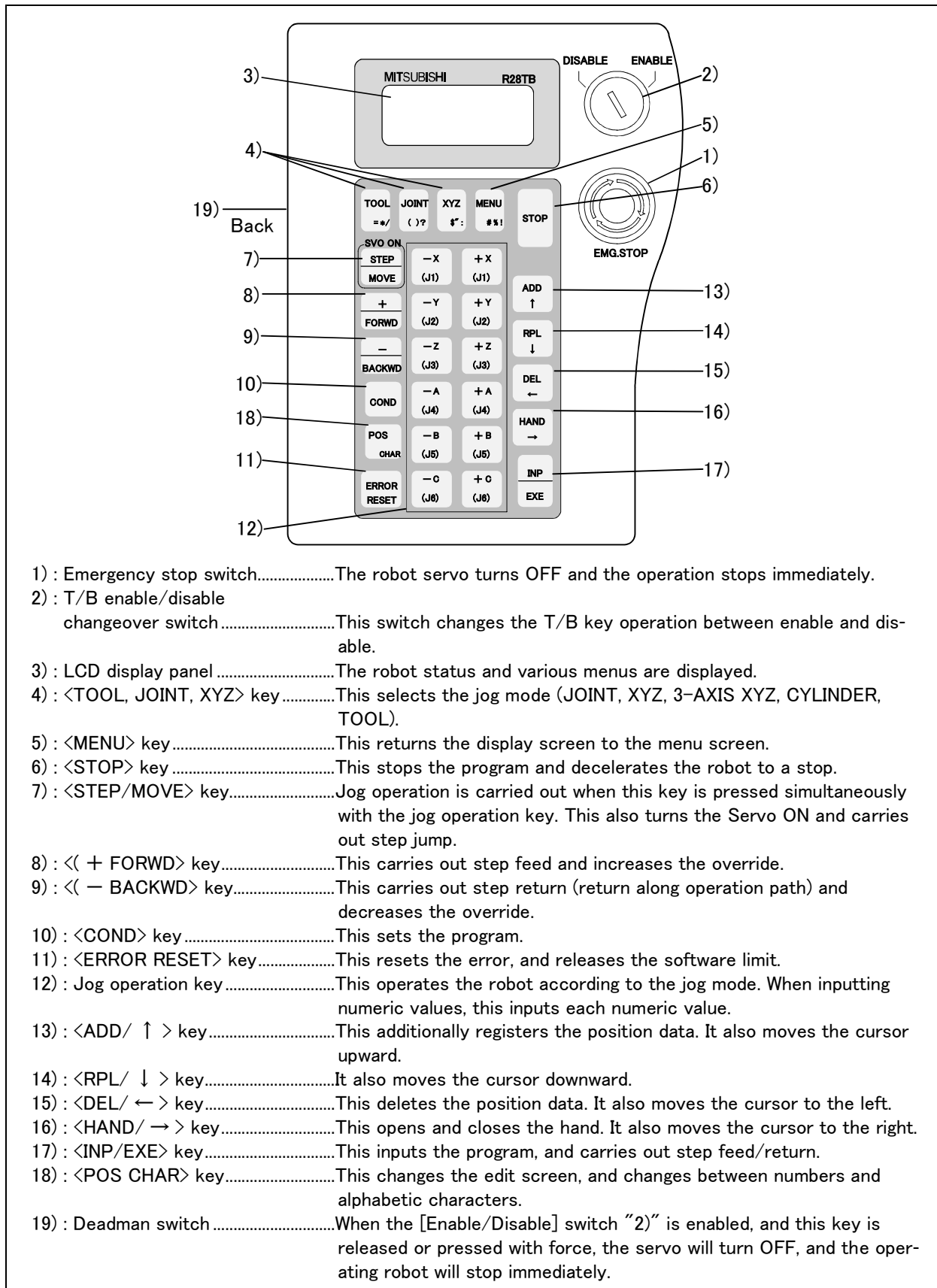
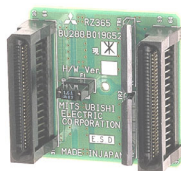

Fig.3-15 : Teaching pendant key layout and main functions

(2) Pneumatic hand interface

- Order type: 2A-RZ365(Sink type)
2A-RZ375(Source type)

Outline



This interface is required to use the robot arm's hand output signals.

- Up to eight hand output points can be used with this interface.
- The eight hand input points can be used without this interface.
- When using more than eight hand input/output points, install the "Parallel I/O unit". Refer to Page 72, "Parallel I/O unit" for detail.
- Use 2A-RZ365 if the external input/output signal logic is of the sink type and 2A-RZ375 for source type signal logic.

Configuration

Table 3-13 : Configuration device

Part name	Type	Qty.	Remarks
Pneumatic hand interface	2A-RZ365/ 2A-RZ375	1pc.	Output 8 points expansion. 2A-RZ365 is the sink type. 2A-RZ375 is the source type.

Specifications

Table 3-14 : Specifications

Item	Specification	Internal circuit
Type	Transistor output	<p><Sink type></p> <p><Source type></p> <p>* GRn = GR1 ~ GR8</p>
No. of output points	8	
Insulation method	Photo coupler insulation	
Rated load voltage	DC24V	
Rated load voltage range	DC21.6 to 26.4VDC	
Max. current load	0.1A/ 1 point (100%)	
Current leak with power OFF	0.1mA or less	
Maximum voltage drop with power ON	DC0.9V(TYP.)	
Response time	OFF-ON: 2ms or less (hardware response time) ON-OFF: 2 ms or less (resistance load) (hardware response time)	
Fuse rating	Fuses 1.6A (each one common)	
Common method	8 points, 1 common	

■ Installation method

This is mounted on the control unit in the controller.

Securely insert the pneumatic hand interface (2A-RZ365/375) into the CNHNDOUT/CNHND connector on the control unit. Refer to separate "Instruction Manual/ Controller setup, basic operation, and maintenance" for details on the installing method.

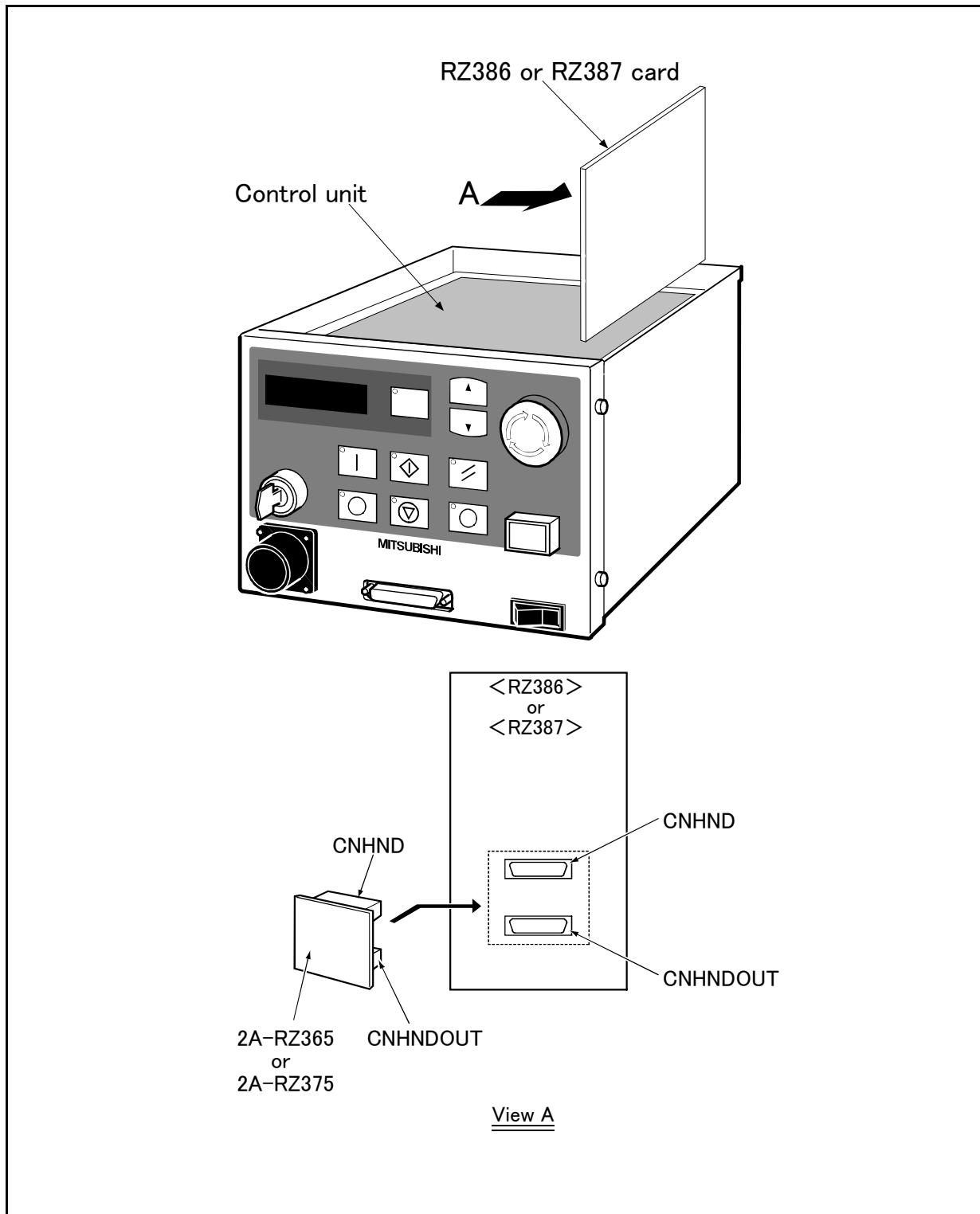

Fig.3-16 : Installation of pneumatic hand interface (CR1B-571 controller)

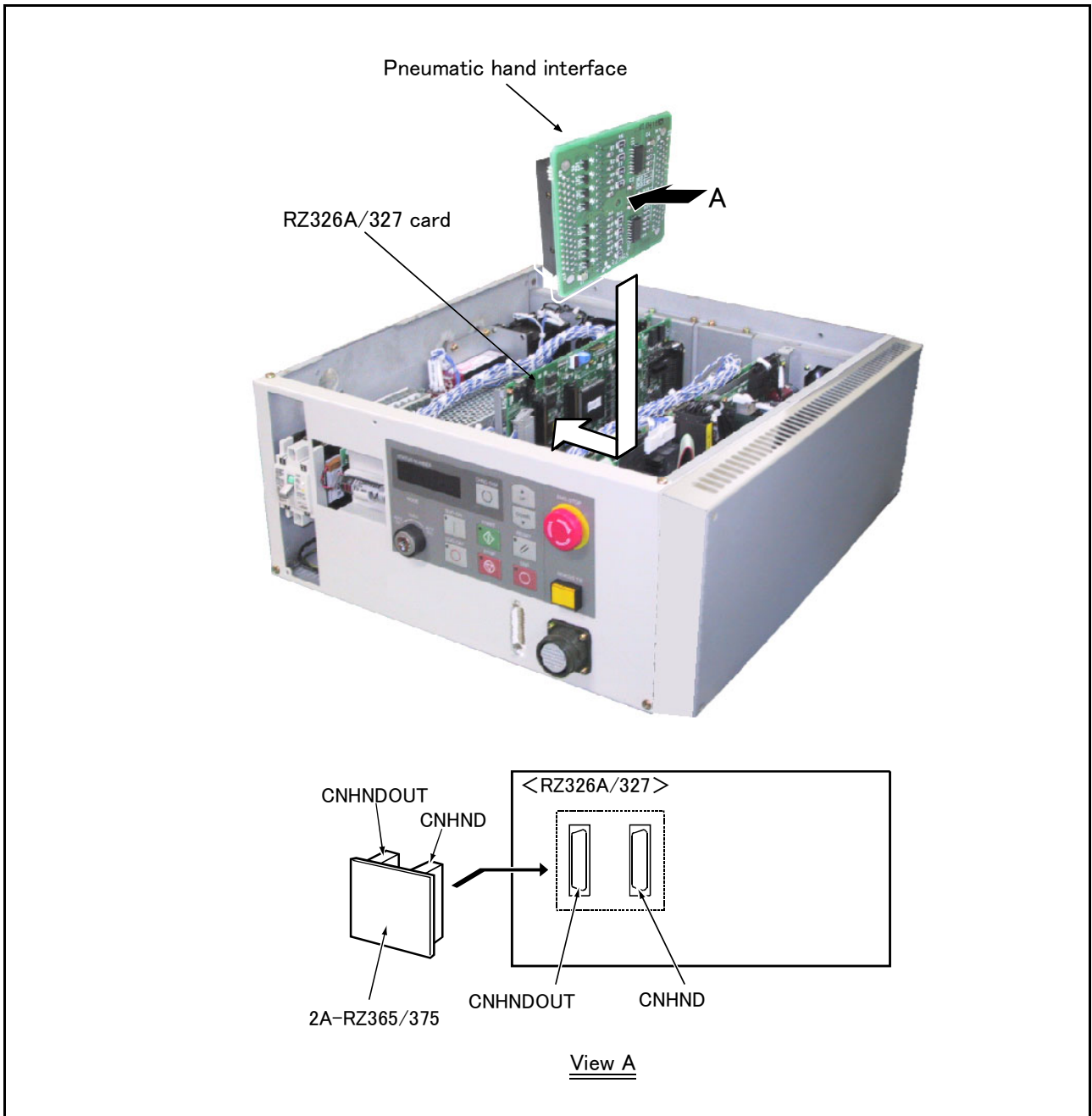

Fig.3-17 : Installation of pneumatic hand interface (CR2B-574 controller)

(3) Controller protection box
(CR1B-571 controller only)

■ Order type : ● CR1B-MB

■ Outline



The controller protection box is used to protect the controller from an oil mist or other operating environment. Put the controller and the earth leakage breaker, etc. in controller protection box, and use it. Since the front cover of the controller protection box can be removed, it is possible to operate the controller's front panel and to install and remove the T/B.

■ Configuration

Table 3-15 : Configuration device

Part name	Type	Qty.	Remarks
Controller protection box	CR1B-MB	1 unit	
Serial number posting label		1	
Protection seal transparent		1	Protection for the serial number posting label.
Cable tie		2	
Power supply wiring cable		1	For connecting the power relay terminal and the controller inside the box.
Grounding cable		1	For connecting the FG terminal and the controller inside the box.
External emergency stop box (Controll box)	HW1X-BV401R	1 unit	Single emergency line. Install at a location outside the controller protection box where operation can be performed easily. The outside dimensions is shown in Fig. 3-20.

■ Specifications

Table 3-16 : Specifications

Item	Unit	Specifications	Remarks
Outside dimensions	mm	414(W) × 492(D) × 202(H)	Excluding protrusions
Mass	Kg	10	
Structure		Self-contained floor type	IP54
Grounding		D class grounding earth	
Coating color		Light gray	Munsell 0.08GY7.64/0.81

(1) The installation of the controller, earth leakage breaker and wiring are constructed by customer.

(2) Prepare the 2 power cable and 1 grounding cable (both AWG#14(2mm²) or more).

(3) The emergency stop box does not come with a cable clamp (wiring connector). The cable clamp must be provided by the customer according to the size of the cable.

The following table shows recommended cable clamps for your reference.

Table 3-17 : Cable clamp for external emergency stop box (recommendation)

Type	JIS wiring tube	Adaptation cable outside diameter	Manufacturer
OA-W1606	G1/2	φ 4 ~ 6	OHM electric Corp
OA-W1608		φ 6 ~ 8	
OA-W1609		φ 7 ~ 9	
OA-W1611		φ 9 ~ 11	
OA-W1613		φ 11 ~ 13	

■ Names of each part

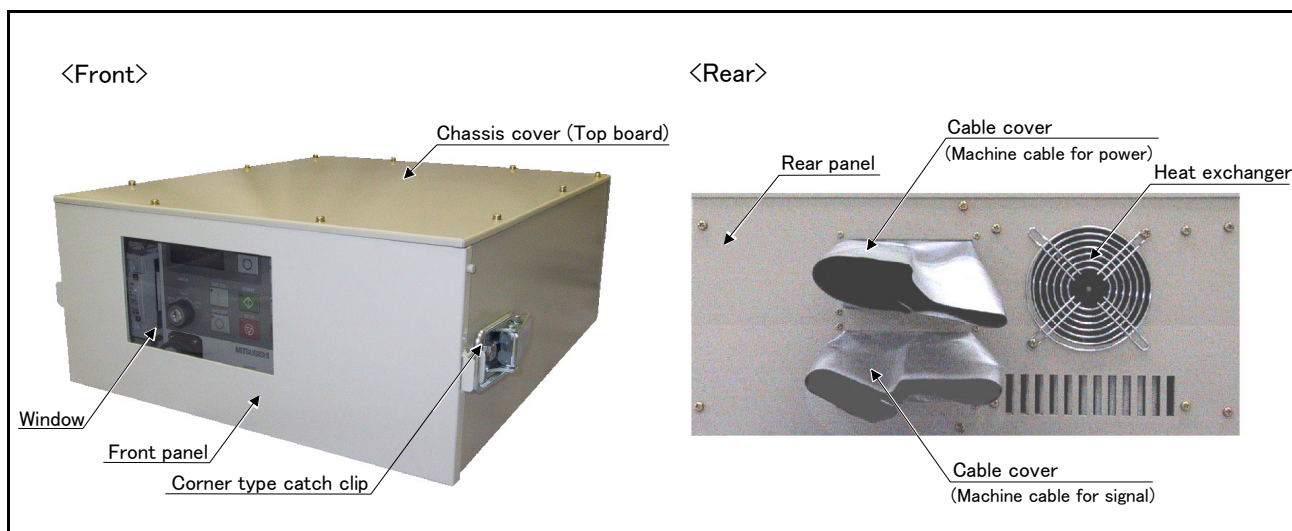

Fig.3-18 : Names of controller parts

■ The outside dimension and controller layout

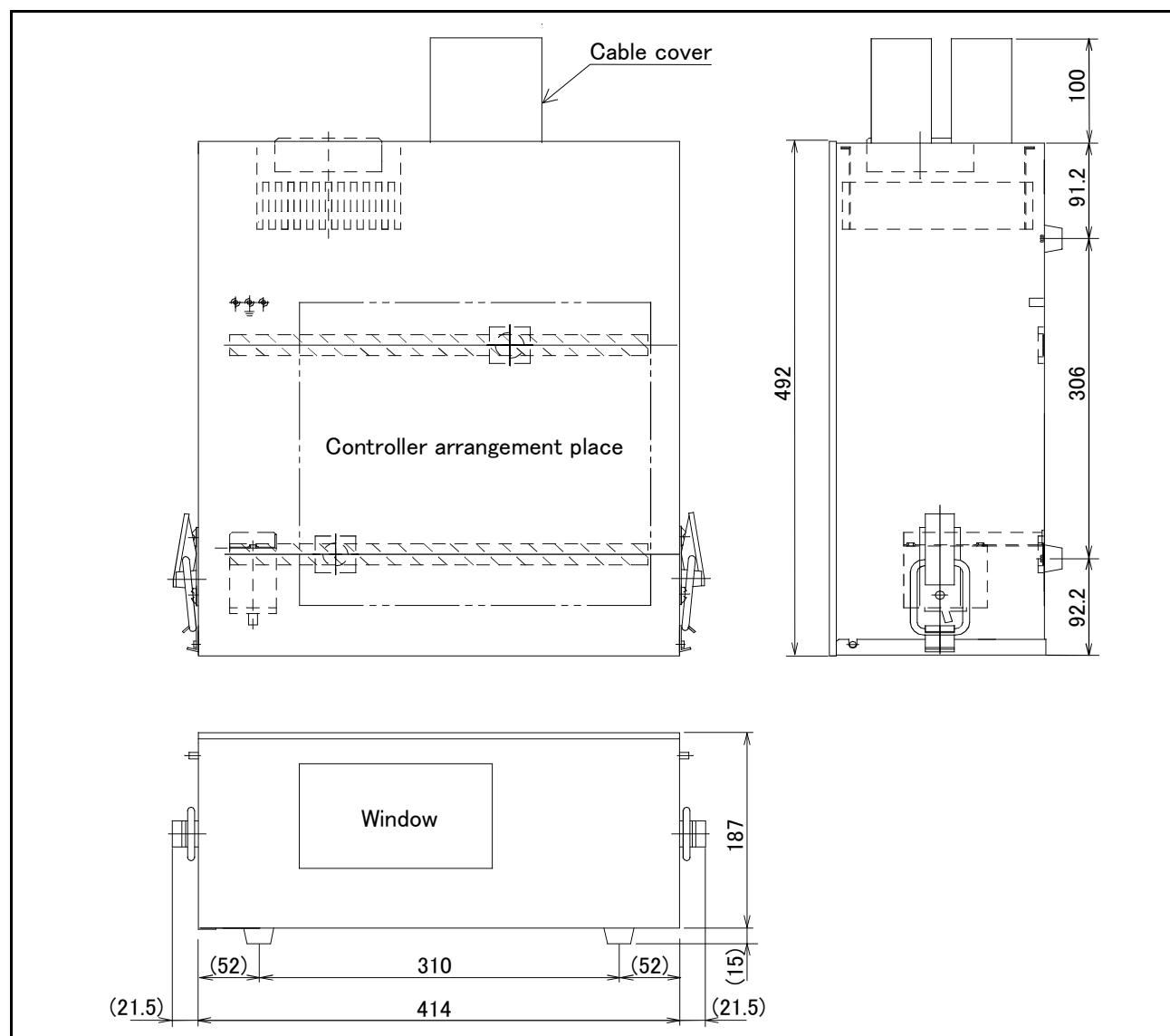

Fig.3-19 : The outside dimension and controller layout

■ The outside dimensions and installation dimensions of emergency stop box

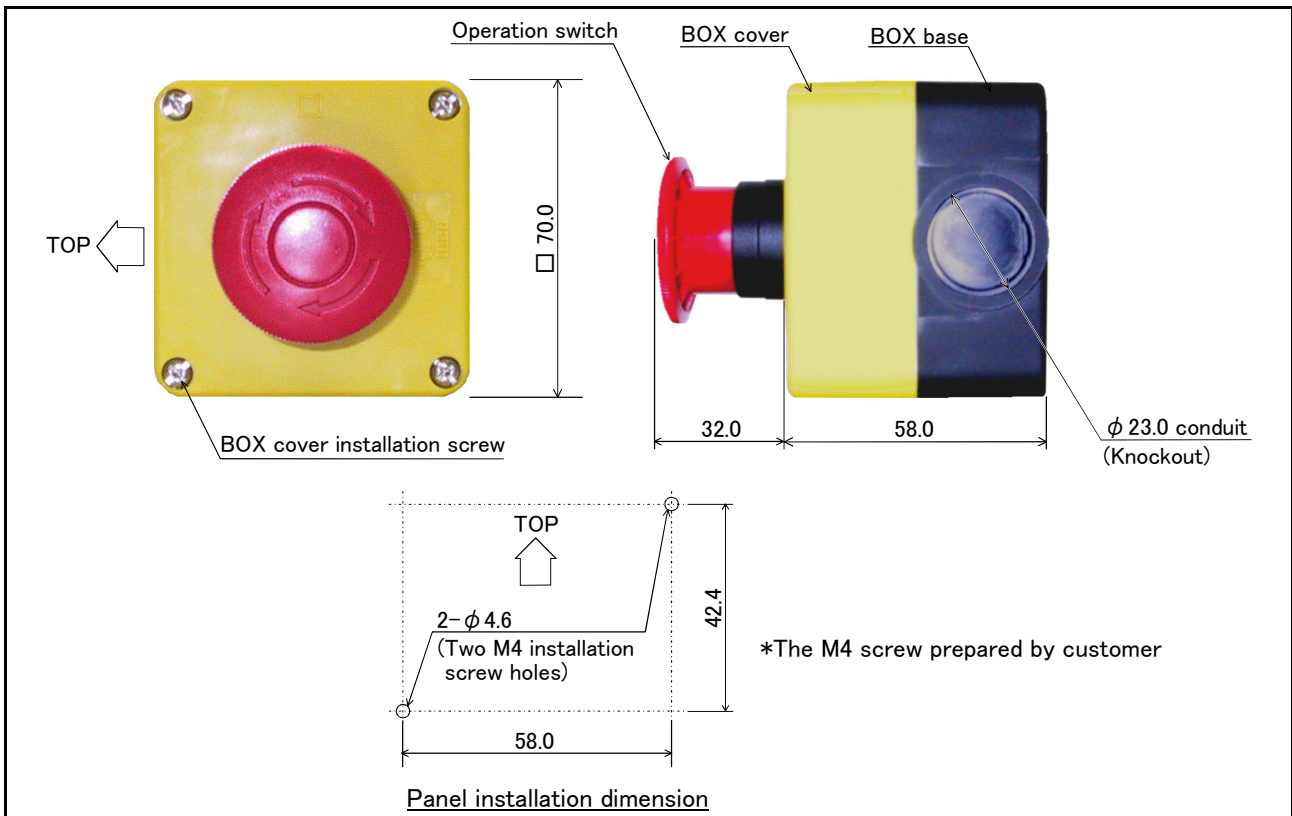

Fig.3-20 : The outside dimensions and installation dimensions of emergency stop box

■ Installation dimensions

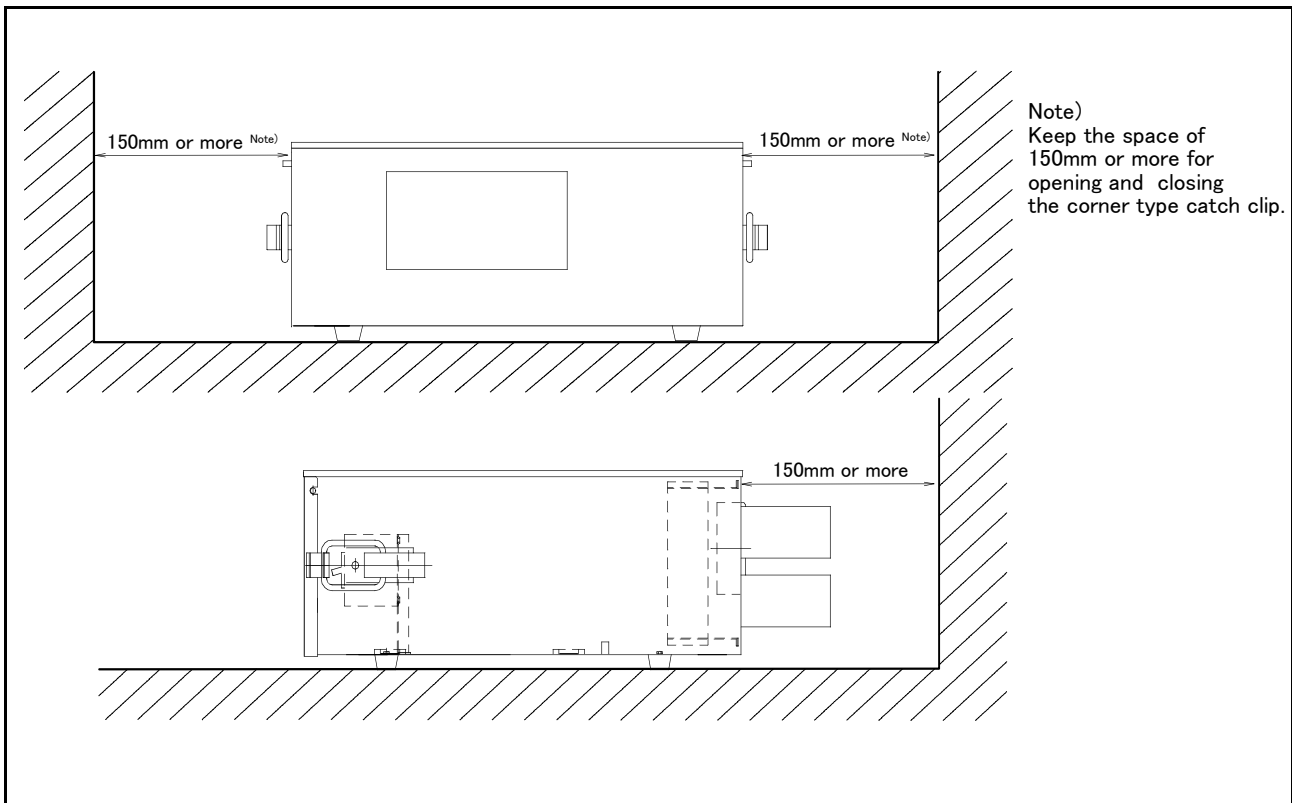
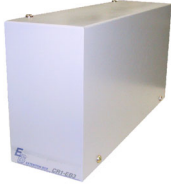

Fig.3-21 : Installation of controller

(4) Expansion option box
(CR1B-571 controller only)

■ Order type : ● CR1-EB3

■ Outline



By installing this expansion option box to the side of the controller, the expansion serial interface, CC-Link interface, Ethernet interface, Additional interface and PROFIBUS interface can be used.
Up to three option cards can be mounted.

■ Configuration

Table 3-18 : Configuration device

Part name	Type	Qty.	Remarks
Expansion option box	CR1-EB3	1	With rubber foot
Installation screw		4	

■ Specifications

Table 3-19 : Specifications

Item	Unit	Specifications	Remarks
Number of slot	slot	3	RT-Bus 1, 2, 3
Power supply method		Power supply is supplied from controller by the RT-Bus coupling(+5V/SG)	
Current value	A	Max. 3	Max. 1A/slot
Ambient temperature	deg.	0 to 40	
Ambient humidity	%RH	45 to 85	Without dew drops
Grounding		D class grounding earth	Grounding from external terminal
Structure		Self-contained floor type opened structure	Note1)
Outside dimensions	mm	85(W) x 290(D) x 165(H)	
Mass	kg	Approx. 3	

Note1) Self-contained floor type, under the condition combined with the body.

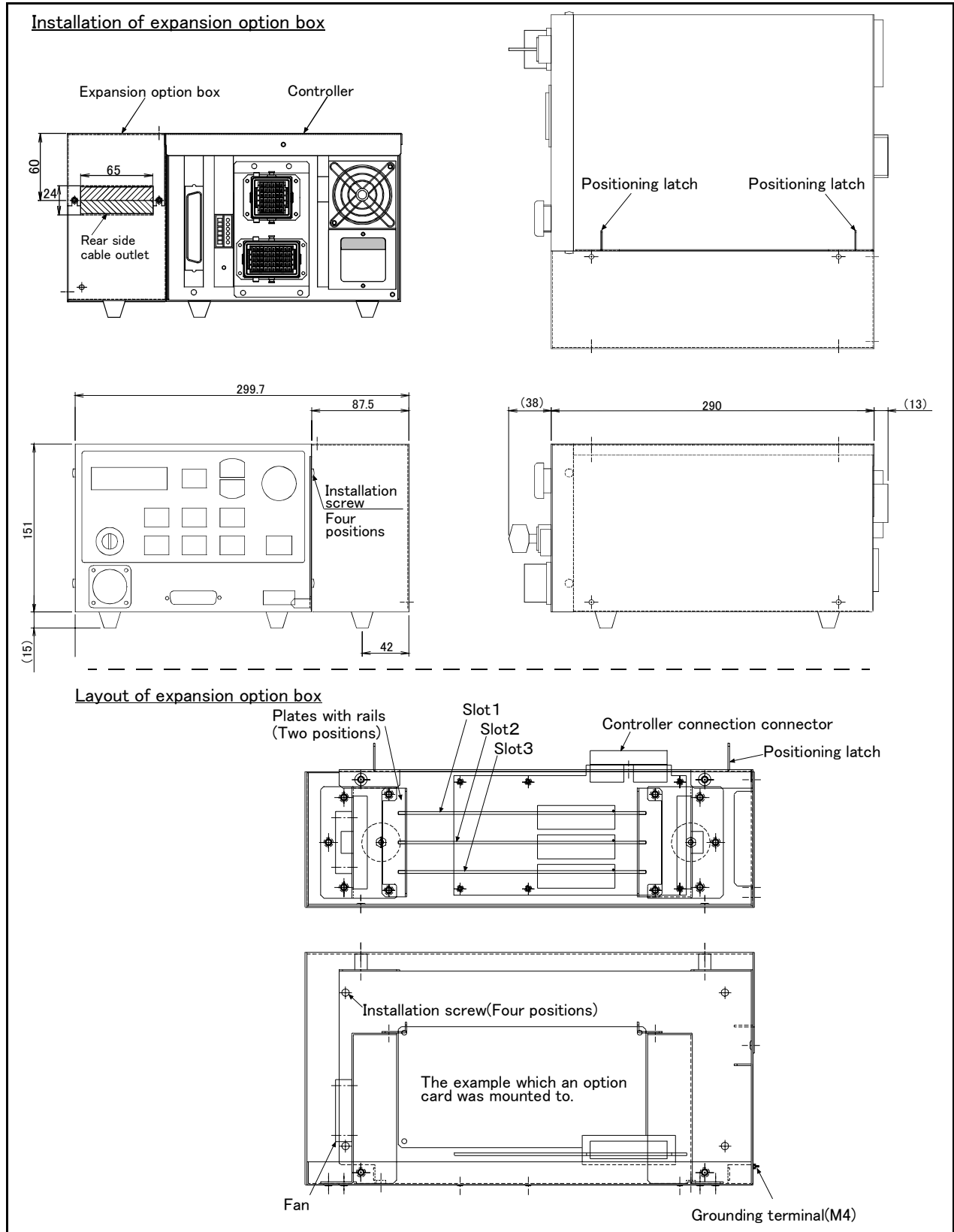

Fig.3-22 : Outside dimensions and layout

■ Installation method

Remove the side plate of the controller, connect the connectors, and fix to the controller with the four fixing screws in the expansion option box.

The option cards mounted in the slot are fixed with the plates with rails.

The cables required for the option card are lead out from the cable outlet on the rear side.

(5) Parallel I/O unit

- Order type: 2A-RZ361(Sink type)
2A-RZ371(Source type)

Outline



This is used to expand the external inputs and outputs.

- The connection cable is not included. Prepare the optional external input/output cable (2A-CBL05 or 2A-CBL15).
- Use 2A-RZ361 if the external input/output signal logic is of the sink type and 2A-RZ371 for source type signal logic.

Configuration

Table 3-20 : Configuration device

Part name	Type	Qty.	Remarks
Parallel I/O unit	2A-RZ361/ 2A-RZ371	1 pc.	Input/output 32 points/32 points 2A-RZ361 is the sink type. 2A-RZ371 is the source type.
Robot I/O link connection connector	NETcable-1	2 sets	Connector with pins. The cable must be prepared and wired by the customer.
Power connection connector	DCcable-2	1 set	Connector with pins. The cable must be prepared and wired by the customer.
Terminator	R-TM	1 pc.	150Ω (1/4W)

Specifications

- Up to eight stations can be connected to this unit. (One station occupies one unit.)
One unit is built into the controller as a standard, so up to seven units can be installed as expansions.
- The power supply (24V) must be prepared by the customer and connected with the power connection cable (DCcable-2)
A separate 24V power supply is required for the input/output circuit wiring.

The detailed specifications of the input/output circuit are the same as the parallel input/output unit mounted as a standard. Refer to Page 55, "3.7 Parallel input/output unit" for details.

Table 3-21 : Electrical specifications of input circuits

Item	Specification	Internal circuit
Type	DC input	<div style="display: flex; flex-direction: column; align-items: center;"> <div style="text-align: center; margin-bottom: 20px;"> <p><Sink type></p> </div> <div style="text-align: center;"> <p><Source type></p> </div> </div>
Number of input points	32	
Insulation method	Photo coupler insulation	
Rated input voltage	12VDC/24VDC	
Rated input current	Approx 3mA/7mA	
Working voltage range	10.2 to 26.4VDC(Ripple factor should be less than 5%.)	
ON voltage/ON current	8VDC or more/ 2mA or more	
OFF voltage/ OFF current	4VDC or less/ 1mA or less	
Input resistance	Approx. 3.3kΩ	
Response time	OFF-ON 10ms or less (24VDC) ON-OFF 10ms or less (24VDC)	
Common method	8 points, 1 common	
External cable connection method	Connector	

Table 3-22 : Electrical specifications for the output circuits

Item		Specification	Internal circuit
Type		Transistor output	<p><Sink type></p> <p><Source type></p>
No. of output points		32	
Insulation method		Photo-coupler insulation	
Rated load voltage		12VDC/24VDC	
Rated load voltage range		10.2 to 30VDC(peak voltage 30VDC)	
Max. load current		0.1A/point (100%)	
Leakage current at OFF		0.1mA or less	
Max. voltage drop at ON		0.9VDC(TYP.)	
Response time	OFF-ON	2ms or less (hardware response time)	
	ON-OFF	2ms or less (Resistance load) (hardware response time)	
Fuse rating		Fuse 3.2A (one per common) Replacement not possible	
Common method		4 points per common (common terminal: 4 points)	
External wire connection method		Connector	
External power supply	Voltage	12VDC/24VDC(10.2 to 30VDC)	
	Current	60mA (TYP. 24VDC per common) (base drive current)	

NETcable-1 (Network cable)

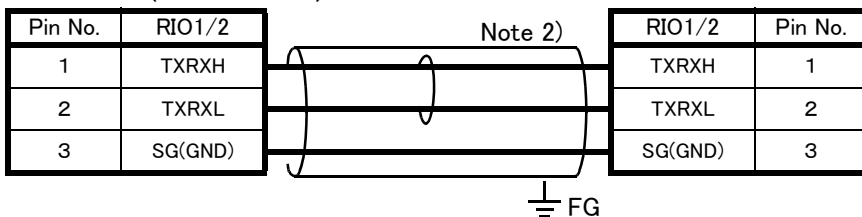

DCcable-2 (Power cable)

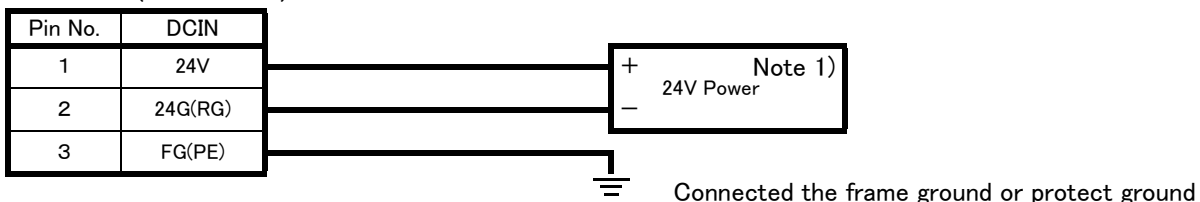

R-TM (Terminator)

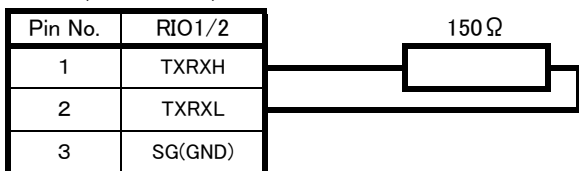

List of parts and manufacturer

Type	Connector type	Contact type	Resistant	Manufacturer
NETcable-1	1-178288-3 (2)	175218-3 (6)	-	AMP
DCcable-2	2-178288-3 (1)	175218-3 (3)	-	AMP
R-TM	1-178288-3 (1)	175218-3 (2)	150Ω (1/4W) (1)	Equivalent to KOA.

Note 1) The 24V power supply is prepared by customer (The power consumption is approx. 0.3A.)

Note 2) The cable for general purpose can be used to the network cable. However, use the twisted shield cable of AWG#22(0.3mm²) or more.

Fig.3-23 : Specifications for the connection cable

■ Installation method

The expansion parallel input/output unit is installed outside of the controller. Connect with the network connection cable (NETcable-1) from the RIO1 connector in the rear of the controller.

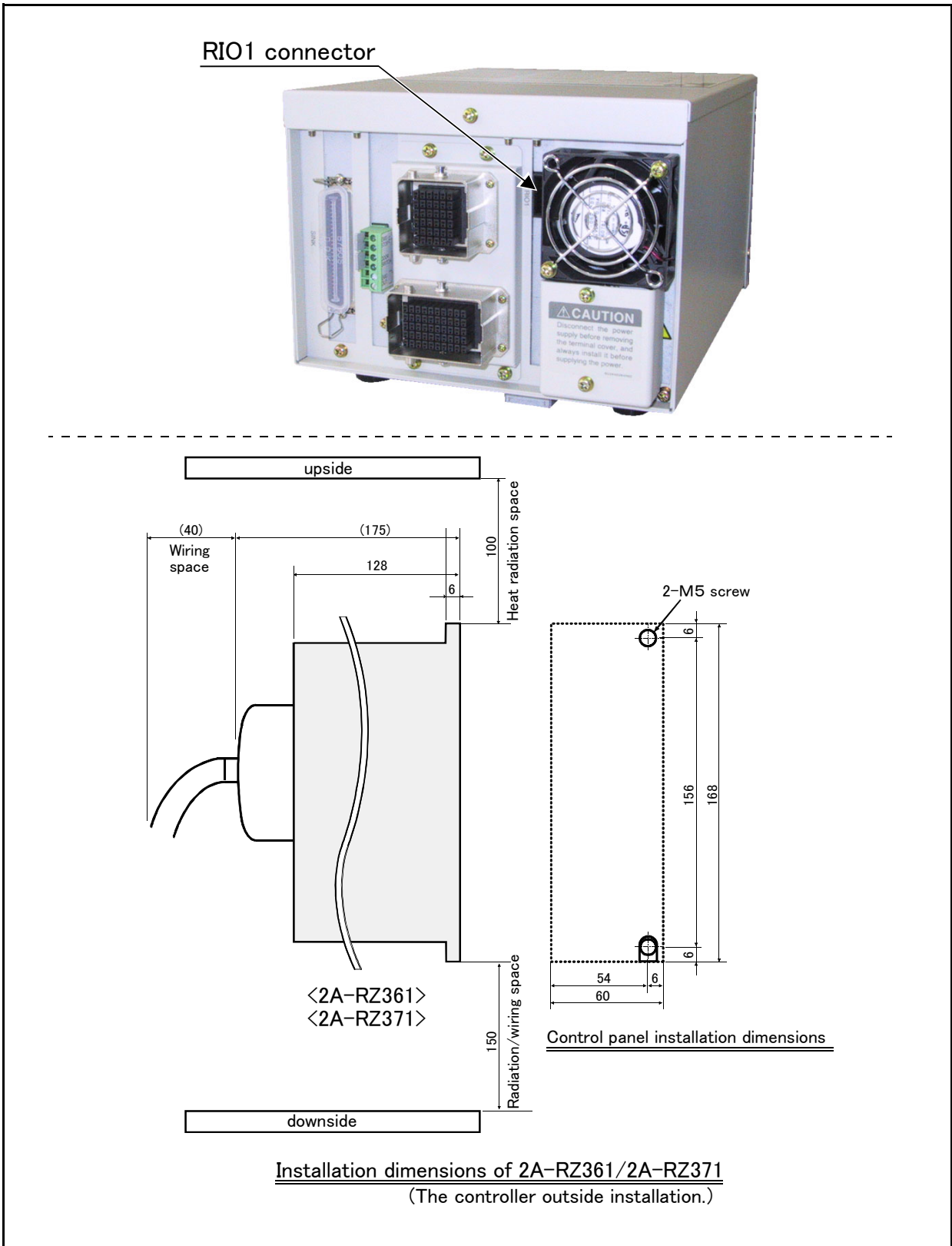

Fig.3-24 : Installing the parallel input/output unit (CR1B-571 controller)

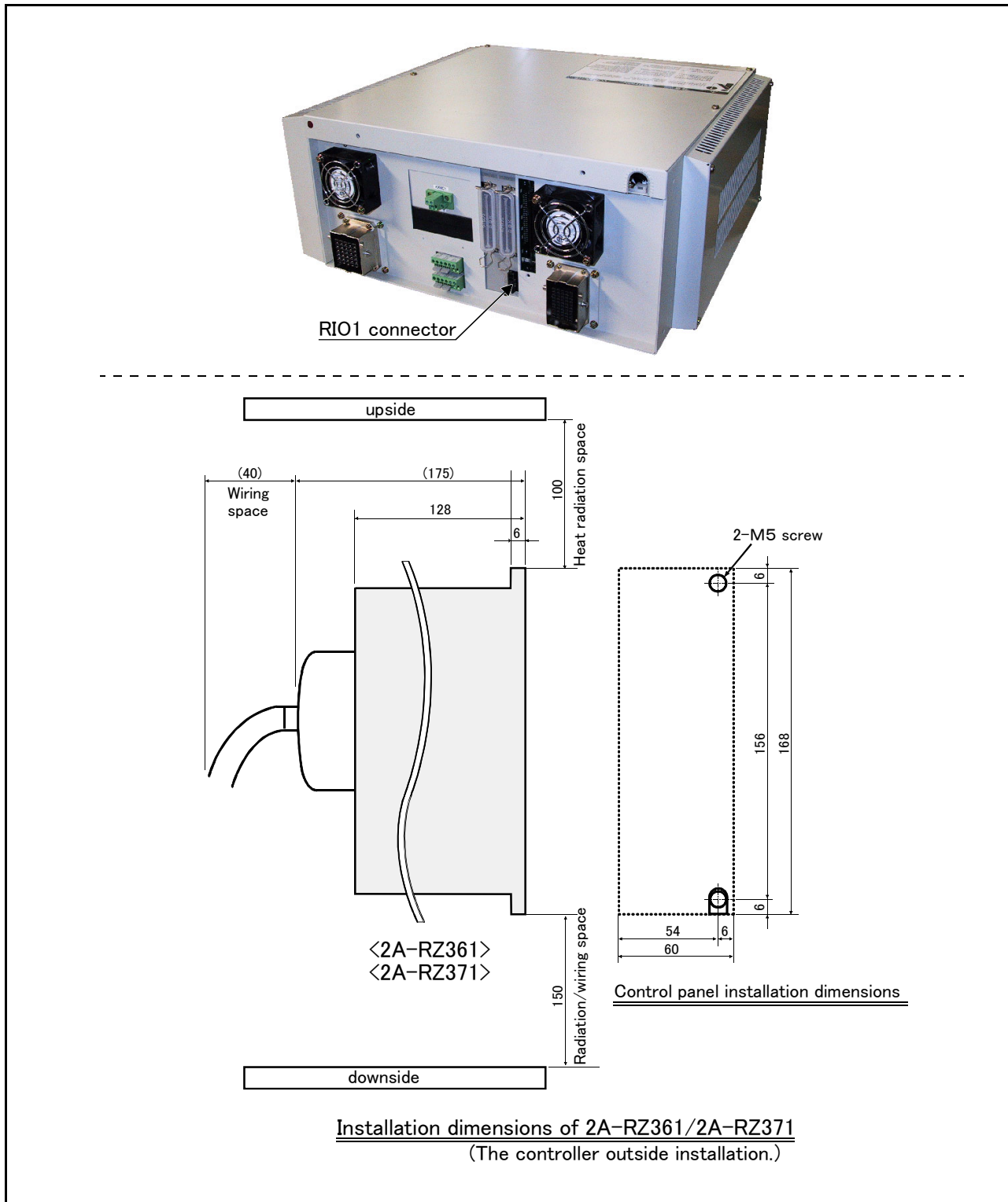

Fig.3-25 : Installing the parallel input/output unit (CR2B-574 controller)

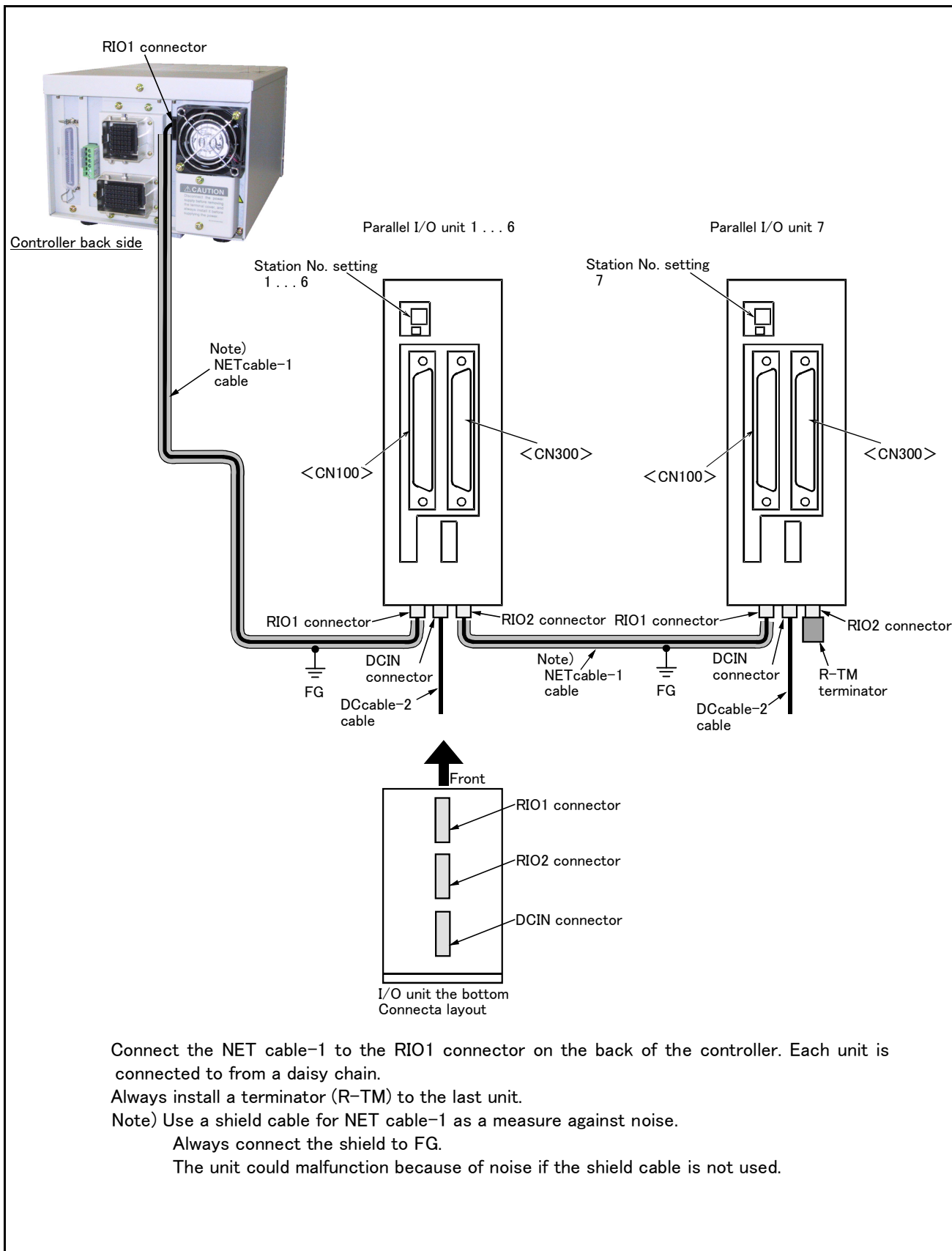

Fig.3-26 : Connection method of expansion parallel input/output unit (CR1B-571 controller)

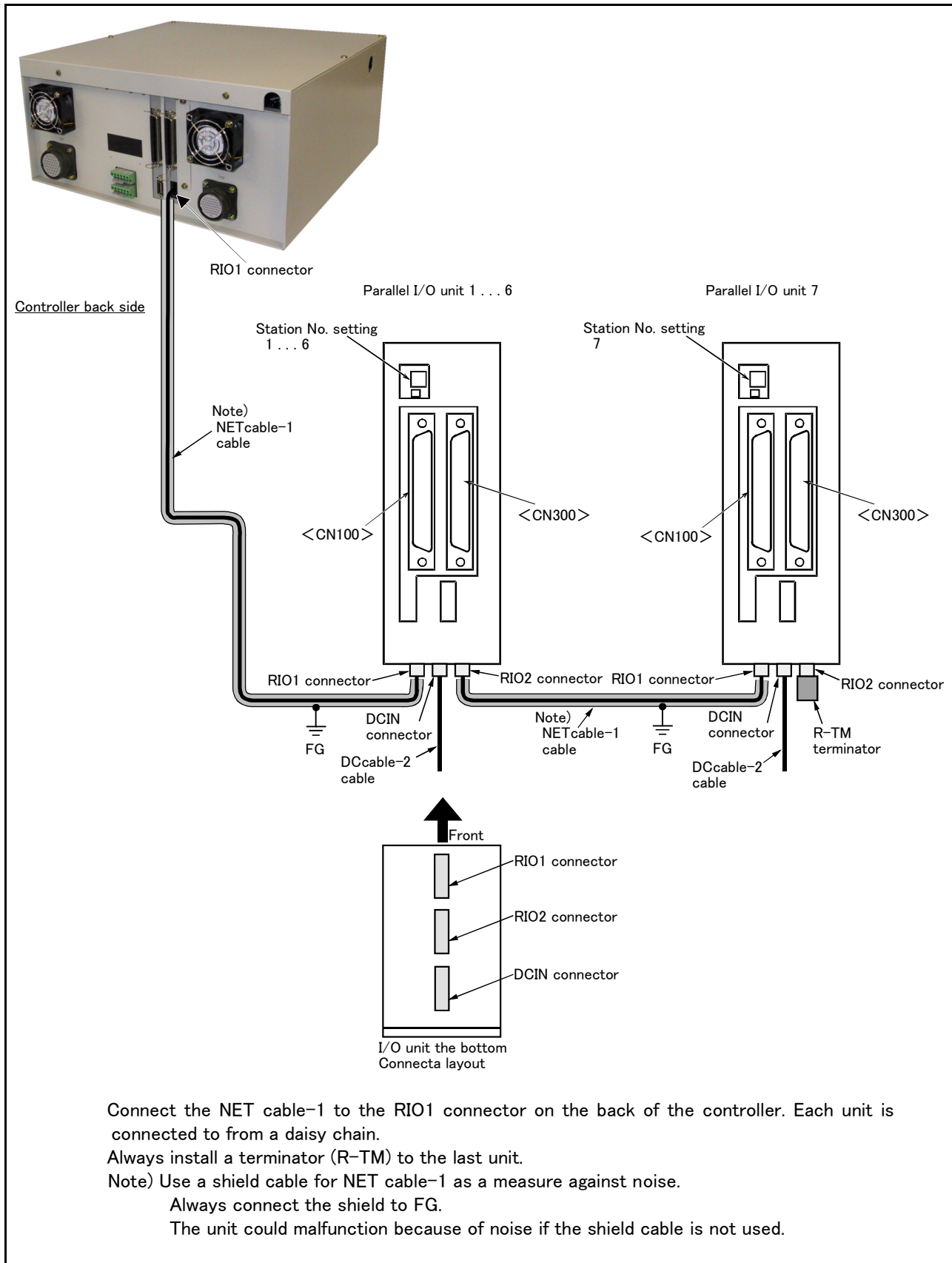

Fig.3-27 : Connection method of expansion parallel input/output unit (CR2B-574 controller)

■ Parallel I/O interface (First expansion unit)

Table 3-23 : Connector CN100pin No. and signal assignment list (2A-CBL □□)

Pin No.	Line color	Function name		Pin No.	Line color	Function name	
		General-purpose	Dedicated/power supply, common			General-purpose	Dedicated/power supply, common
1	Orange/Red A		FG	26	Orange/Blue A		FG
2	Gray/Red A		0V:For pins 4-7	27	Gray/Blue A		0V:For pins 29-32
3	White/Red A		12V/24V:For pins 4-7	28	White/Blue A		12V/24V:For pins 29-32
4	Yellow/Red A	General-purpose output 32		29	Yellow/Blue A	General-purpose output 36	
5	Pink/Red A	General-purpose output 33		30	Pink/Blue A	General-purpose output 37	
6	Orange/Red B	General-purpose output 34		31	Orange/Blue B	General-purpose output 38	
7	Gray/Red B	General-purpose output 35		32	Gray/Blue B	General-purpose output 39	
8	White/Red B		0V:For pins 10-13	33	White/Blue B		0V:For pins 35-38
9	Yellow/Red B		12V/24V:For pins 10-13	34	Yellow/Blue B		12V/24V:For pins 35-38
10	Pink/Red B	General-purpose output 40		35	Pink/Blue B	General-purpose output 44	
11	Orange/Red C	General-purpose output 41		36	Orange/Blue C	General-purpose output 45	
12	Gray/Red C	General-purpose output 42		37	Gray/Blue C	General-purpose output 46	
13	White/Red C	General-purpose output 43		38	White/Blue C	General-purpose output 47	
14	Yellow/Red C		COM0:For pins 15-22 ^{Note1)}	39	Yellow/Blue C		COM1:For pins 40-47 ^{Note1)}
15	Pink/Red C	General-purpose input 32		40	Pink/Blue C	General-purpose input 40	
16	Orange/Red D	General-purpose input 33		41	Orange/Blue D	General-purpose input 41	
17	Gray/Red D	General-purpose input 34		42	Gray/Blue D	General-purpose input 42	
18	White/Red D	General-purpose input 35		43	White/Blue D	General-purpose input 43	
19	Yellow/Red D	General-purpose input 36		44	Yellow/Blue D	General-purpose input 44	
20	Pink/Red D	General-purpose input 37		45	Pink/Blue D	General-purpose input 45	
21	Orange/Red E	General-purpose input 38		46	Orange/Blue E	General-purpose input 46	
22	Gray/Red E	General-purpose input 39		47	Gray/Blue E	General-purpose input 47	
23	White/Red E		Reserved	48	White/Blue E		Reserved
24	Yellow/Red E		Reserved	49	Yellow/Blue E		Reserved
25	Pink/Red E		Reserved	50	Pink/Blue E		Reserved

Note1) Sink type:24V/12V(COM), Source type:0V(COM)

Table 3-24 : Connector CN300pin No. and signal assignment list (2A-CBL □□)

Pin No.	Line color	Function name		Pin No.	Line color	Function name	
		General-purpose	Dedicated/power supply, common			General-purpose	Dedicated/power supply, common
1	Orange/Red A		FG	26	Orange/Blue A		FG
2	Gray/Red A		0V:For pins 4-7	27	Gray/Blue A		0V:For pins 29-32
3	White/Red A		12V/24V:For pins 4-7	28	White/Blue A		12V/24V:For pins 29-32
4	Yellow/Red A	General-purpose output 48		29	Yellow/Blue A	General-purpose output 52	
5	Pink/Red A	General-purpose output 49		30	Pink/Blue A	General-purpose output 53	
6	Orange/Red B	General-purpose output 50		31	Orange/Blue B	General-purpose output 54	
7	Gray/Red B	General-purpose output 51		32	Gray/Blue B	General-purpose output 55	
8	White/Red B		0V:For pins 10-13	33	White/Blue B		0V:For pins 35-38
9	Yellow/Red B		12V/24V:For pins 10-13	34	Yellow/Blue B		12V/24V:For pins 35-38
10	Pink/Red B	General-purpose output 56		35	Pink/Blue B	General-purpose output 60	
11	Orange/Red C	General-purpose output 57		36	Orange/Blue C	General-purpose output 61	
12	Gray/Red C	General-purpose output 58		37	Gray/Blue C	General-purpose output 62	
13	White/Red C	General-purpose output 59		38	White/Blue C	General-purpose output 63	
14	Yellow/Red C		COM0:For pins 15-22 ^{Note1)}	39	Yellow/Blue C		COM1:For pins 40-47 ^{Note1)}
15	Pink/Red C	General-purpose input 48		40	Pink/Blue C	General-purpose input 56	
16	Orange/Red D	General-purpose input 49		41	Orange/Blue D	General-purpose input 57	
17	Gray/Red D	General-purpose input 50		42	Gray/Blue D	General-purpose input 58	
18	White/Red D	General-purpose input 51		43	White/Blue D	General-purpose input 59	
19	Yellow/Red D	General-purpose input 52		44	Yellow/Blue D	General-purpose input 60	
20	Pink/Red D	General-purpose input 53		45	Pink/Blue D	General-purpose input 61	
21	Orange/Red E	General-purpose input 54		46	Orange/Blue E	General-purpose input 62	
22	Gray/Red E	General-purpose input 55		47	Gray/Blue E	General-purpose input 63	
23	White/Red E		Reserved	48	White/Blue E		Reserved
24	Yellow/Red E		Reserved	49	Yellow/Blue E		Reserved
25	Pink/Red E		Reserved	50	Pink/Blue E		Reserved

Note1) Sink type:24V/12V(COM), Source type:0V(COM)

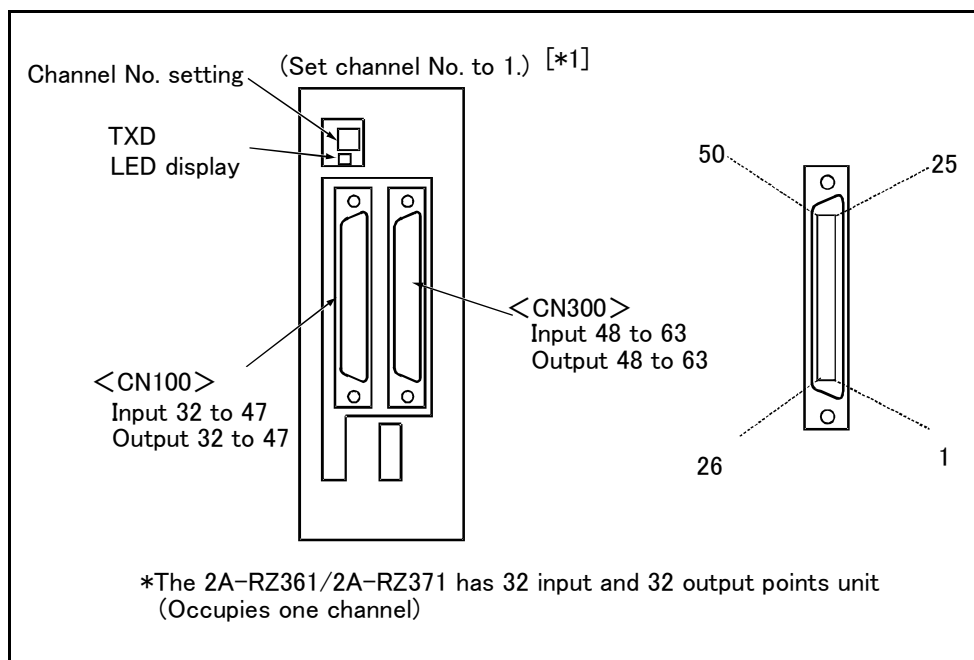

Fig.3-28 : Parallel input/output unit <2A-RZ361/2A-RZ371:First expansion> connection and pin layout

⚠ CAUTION

[*1] For the 1st expansion unit, set the channel No. to "1".
The channel No. of 8 to F is used for the maker test. If any value of 8 to F is set, it may be dangerous since the robot unexpectedly moves. Don't set any value of 8 to F.

■ Parallel I/O interface (Second expansion unit)

Table 3-25 : Connector CN100pin No. and signal assignment list (2A-CBL □□)

Pin No.	Line color	Function name		Pin No.	Line color	Function name			
		General-purpose	Dedicated/power supply, common			General-purpose	Dedicated/power supply, common		
1	Orange/Red A	General-purpose output 64	FG	26	Orange/Blue A	General-purpose output 68	FG		
2	Gray/Red A		0V:For pins 4-7	27	Gray/Blue A		0V:For pins 29-32		
3	White/Red A		12V/24V:For pins 4-7	28	White/Blue A		12V/24V:For pins 29-32		
4	Yellow/Red A		General-purpose output 65	0V:For pins 10-13 12V/24V:For pins 10-13	29		Yellow/Blue A	General-purpose output 70	0V:For pins 35-38 12V/24V:For pins 35-38
5	Pink/Red A				30		Pink/Blue A		
6	Orange/Red B	General-purpose output 66	32		Gray/Blue B	General-purpose output 71			
7	Gray/Red B	General-purpose output 67	33		White/Blue B	General-purpose output 72			
8	White/Red B	COM0:For pins 15-22 ^{Note1)}	34		Yellow/Blue B		General-purpose input 72		
9	Yellow/Red B		35	Pink/Blue B	General-purpose input 73				
10	Pink/Red B		36	Orange/Blue C		General-purpose input 74			
11	Orange/Red C		General-purpose output 73	37		Gray/Blue C	General-purpose input 75		
12	Gray/Red C		General-purpose output 74	38	White/Blue C	General-purpose input 76			
13	White/Red C	General-purpose output 75	39	Yellow/Blue C	General-purpose input 77				
14	Yellow/Red C	General-purpose input 64	COM1:For pins 40-47 ^{Note1)}	40	Pink/Blue C	General-purpose input 78			
15	Pink/Red C			41	Orange/Blue D		General-purpose input 79		
16	Orange/Red D			General-purpose input 65	42		Gray/Blue D	Reserved	
17	Gray/Red D			General-purpose input 66	43		White/Blue D		Reserved
18	White/Red D			General-purpose input 67	44		Yellow/Blue D		
19	Yellow/Red D	General-purpose input 68	45	Pink/Blue D	Reserved				
20	Pink/Red D	General-purpose input 69	46	Orange/Blue E		Reserved			
21	Orange/Red E	General-purpose input 70	47	Gray/Blue E			Reserved		
22	Gray/Red E	General-purpose input 71	48	White/Blue E	Reserved				
23	White/Red E	Reserved	49	Yellow/Blue E		Reserved			
24	Yellow/Red E		Reserved	50			Pink/Blue E	Reserved	
25	Pink/Red E		Reserved						

Note1) Sink type:24V/12V(COM), Source type:0V(COM)

Table 3-26 : Connector CN300pin No. and signal assignment list (2A-CBL □□)

Pin No.	Line color	Function name		Pin No.	Line color	Function name			
		General-purpose	Dedicated/power supply, common			General-purpose	Dedicated/power supply, common		
1	Orange/Red A	General-purpose output 80	FG	26	Orange/Blue A	General-purpose output 84	FG		
2	Gray/Red A		0V:For pins 4-7	27	Gray/Blue A		0V:For pins 29-32		
3	White/Red A		12V/24V:For pins 4-7	28	White/Blue A		12V/24V:For pins 29-32		
4	Yellow/Red A		General-purpose output 81	0V:For pins 10-13 12V/24V:For pins 10-13	29		Yellow/Blue A	General-purpose output 85	0V:For pins 35-38 12V/24V:For pins 35-38
5	Pink/Red A				30		Pink/Blue A		
6	Orange/Red B	General-purpose output 82	32		Gray/Blue B	General-purpose output 86			
7	Gray/Red B	General-purpose output 83	33		White/Blue B	General-purpose output 87			
8	White/Red B	COM0:For pins 15-22 ^{Note1)}	34		Yellow/Blue B	General-purpose output 92			
9	Yellow/Red B		35	Pink/Blue B	General-purpose output 93				
10	Pink/Red B		General-purpose output 88	36			Orange/Blue C	General-purpose output 94	
11	Orange/Red C		General-purpose output 89	37		Gray/Blue C	General-purpose output 95		
12	Gray/Red C		General-purpose output 90	38	White/Blue C	COM1:For pins 40-47 ^{Note1)}			
13	White/Red C	General-purpose output 91	39	Yellow/Blue C	General-purpose input 88				
14	Yellow/Red C	General-purpose input 80	40	Pink/Blue C			General-purpose input 89		
15	Pink/Red C		41	Orange/Blue D		General-purpose input 90			
16	Orange/Red D		General-purpose input 81	42	Gray/Blue D	General-purpose input 91			
17	Gray/Red D		General-purpose input 82	43	White/Blue D	General-purpose input 92			
18	White/Red D		General-purpose input 83	44	Yellow/Blue D	General-purpose input 93			
19	Yellow/Red D	General-purpose input 84	45	Pink/Blue D	Reserved				
20	Pink/Red D	General-purpose input 85	46	Orange/Blue E		Reserved			
21	Orange/Red E	General-purpose input 86	47	Gray/Blue E			Reserved		
22	Gray/Red E	General-purpose input 87	48	White/Blue E	Reserved				
23	White/Red E	Reserved	49	Yellow/Blue E		Reserved			
24	Yellow/Red E		Reserved	50			Pink/Blue E	Reserved	
25	Pink/Red E		Reserved						

Note1) Sink type:24V/12V(COM), Source type:0V(COM)

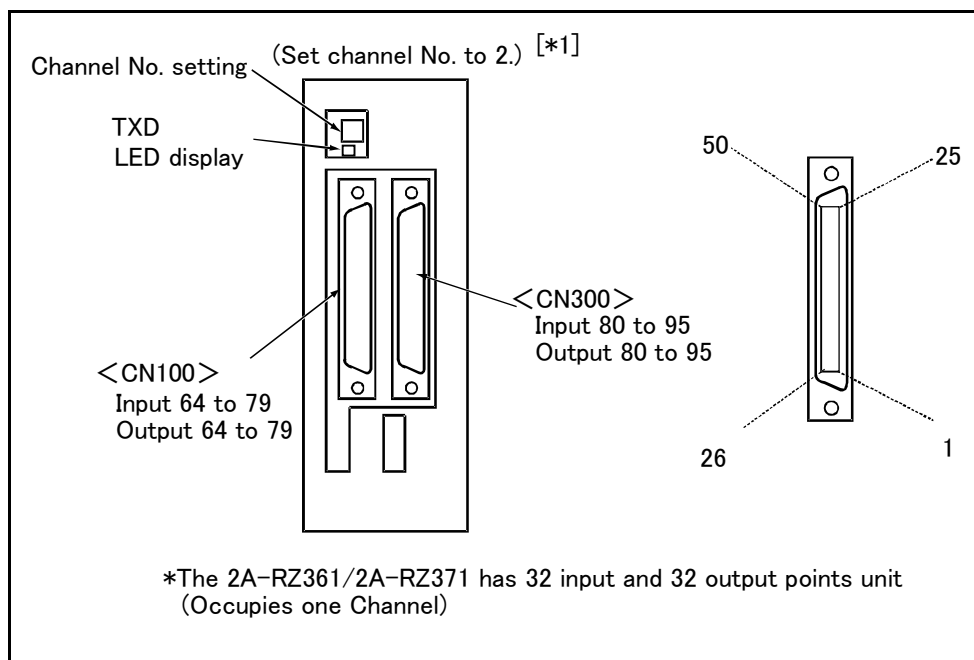

Fig.3-29 : Parallel input/output unit <2A-RZ361/2A-RZ371:Second expansion unit> connection and pin layout

⚠ CAUTION

[*1] For the 2nd expansion unit, set the channel No. to "2".

The channel No. of 8 to F is used for the maker test. If any value of 8 to F is set, it may be dangerous since the robot unexpectedly moves. Don't set any value of 8 to F.

Table 3-27 lists the correspondence between the station numbers to be set and the I/O signal assignment. Refer to this table when the third and subsequent units are used.

Table 3-27 : Station Number Settings and I/O Signal Assignment

Unit No.	Station number setting	CN100	CN300
1st unit	1	Input: 32 ~ 47 Output: 32 ~ 47	Input: 48 ~ 63 Output: 48 ~ 63
2nd unit	2	Input: 64 ~ 79 Output: 64 ~ 79	Input: 80 ~ 95 Output: 80 ~ 95
3rd unit	3	Input: 96 ~ 111 Output: 96 ~ 111	Input: 112 ~ 127 Output: 112 ~ 127
4th unit	4	Input: 128 ~ 143 Output: 128 ~ 143	Input: 144 ~ 159 Output: 144 ~ 159
5th unit	5	Input: 160 ~ 175 Output: 160 ~ 175	Input: 176 ~ 191 Output: 176 ~ 191
6th unit	6	Input: 192 ~ 207 Output: 192 ~ 207	Input: 208 ~ 223 Output: 208 ~ 223
7th unit	7	Input: 224 ~ 239 Output: 224 ~ 239	Input: 240 ~ 255 Output: 240 ~ 255

(6) External I/O cable

■ Order type: 2A-CBL □□ Note) The numbers in the boxes □□ refer to the length. (05: 5m、15: 15m)

■ Outline



This is the dedicated cable used to connect an external peripheral device to the connector on the parallel input/output unit.

One end matches the connector on the parallel input/output unit, and the other end is free. Connect the peripheral device's input/output signal using the free end.

One cable correspond to the input 16 points and output 16 points.

Two cables are needed to connection of (input 32 points and output 32 points) with built-in standard.

This cable can also be used to connect the parallel input/output connector that is supplied as standard equipment with the controller.

■ Configuration

Table 3-28 : Configuration device

Part name	Type	Qty.	Remarks
External I/O cable	2A-CBL □□	1pc.	5m or 15m

■ Specifications

Table 3-29 : Specifications

Items	Specifications
Number of cables x cable size	50 pairs x AWG #28
Total length	5m or 15m

■ Connector pin numbers and cable colors

Table 3-30 : Connector pin numbers and cable colors

Pin no.	Cable colors	Pin no.	Cable colors	Pin no.	Cable colors	Pin no.	Cable colors	Pin no.	Cable colors
1	Orange/Red A	11	Orange/Red C	21	Orange/Red E	31	Orange/Blue B	41	Orange/Blue D
2	Gray/Red A	12	Gray/Red C	22	Gray/Red E	32	Gray/Blue B	42	Gray/Blue D
3	White/Red A	13	White/Red C	23	White/Red E	33	White/Blue B	43	White/Blue D
4	Yellow/Red A	14	Yellow/Red C	24	Yellow/Red E	34	Yellow/Blue B	44	Yellow/Blue D
5	Pink/Red A	15	Pink/Red C	25	Pink/Red E	35	Pink/Blue B	45	Pink/Blue D
6	Orange/Red B	16	Orange/Red D	26	Orange/Blue A	36	Orange/Blue C	46	Orange/Blue E
7	Gray/Red B	17	Gray/Red D	27	Gray/Blue A	37	Gray/Blue C	47	Gray/Blue E
8	White/Red B	18	White/Red D	28	White/Blue A	38	White/Blue C	48	White/Blue E
9	Yellow/Red B	19	Yellow/Red D	29	Yellow/Blue A	39	Yellow/Blue C	49	Yellow/Blue E
10	Pink/Red B	20	Pink/Red D	30	Pink/Blue A	40	Pink/Blue C	50	Pink/Blue E

■ Connections and outside dimensions

The sheath of each signal cable (50 lines) is color indicated and marked with dots. Refer to the cable color specifications in "Table 3-30: Connector pin numbers and cable colors" when making the connections.

(Eg.) Pin number: color indication

1 : Orange / Red / A

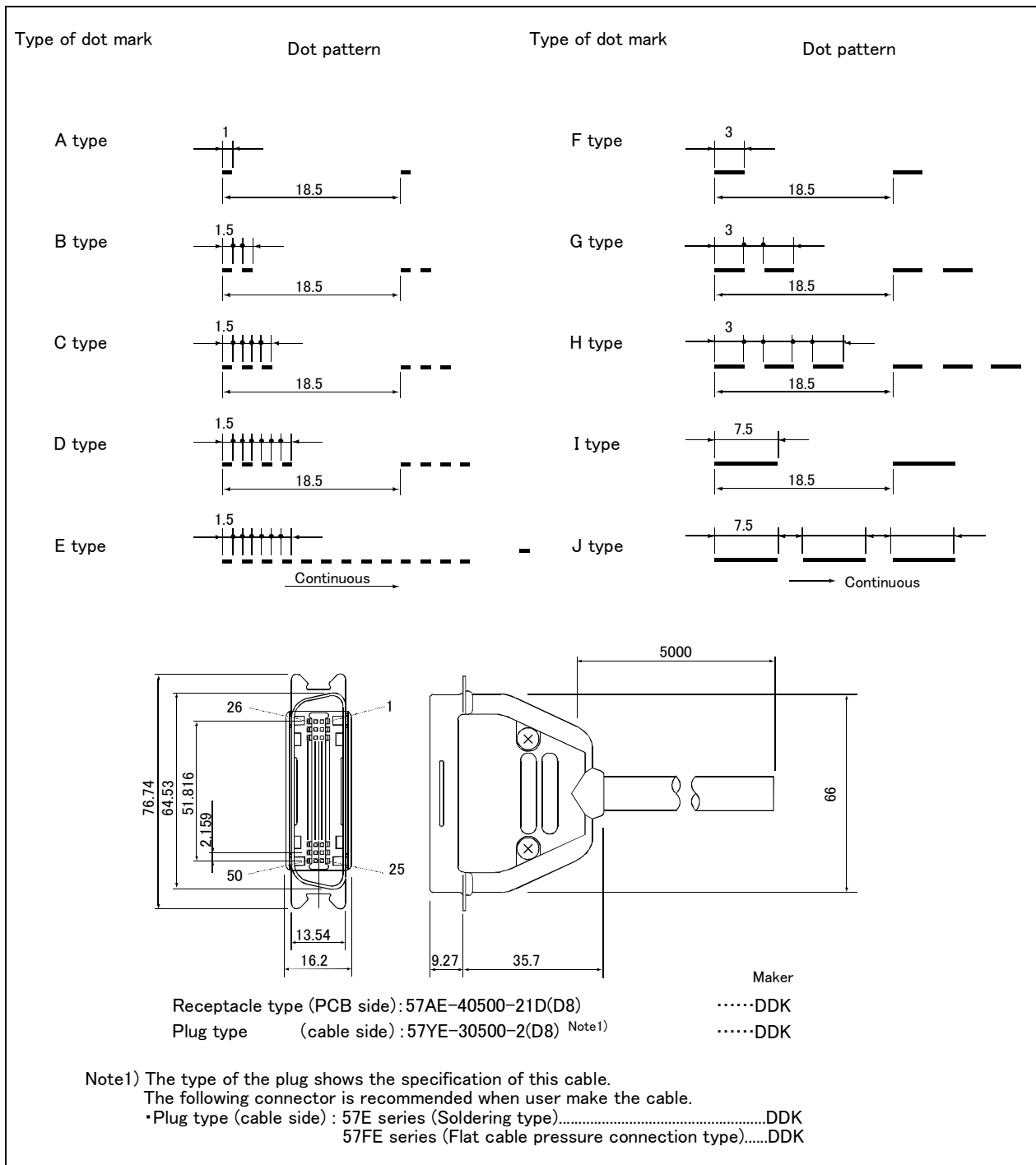
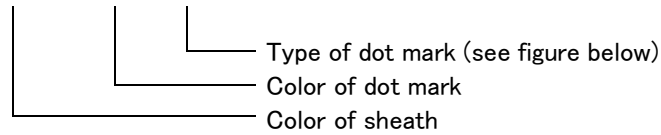

Fig.3-30 : Connections and outside dimensions

(7) Personal computer cable

- Order type: ● For PC/AT : RS-MAXY-CBL
RS-AT-RCBL (For expansion option box(CR1-EB3).)

Outline



This is the RS-232C interface cable used for connecting the controller with a personal computer. The personal computer on hand may be usable with the above interface cable. Confirm the connection specifications when placing an order.

Personal computer cables for the PC/AT compatible model is available.

The cable for the NEC PC9821 (half-pitch 14-pin) must be manufactured by the customer. Use "RS-AT-RCBL" when you use expansion serial I/F with the expansion option box.

Configuration

Table 3-31 : Configuration device

Part name	Type	Qty.	Remarks
Personal computer cable (for PC/AT)	RS-MAXY-CBL	1pc.	3m, D-SUB 9 pin ^{Note1)}
	RS-AT-RCBL	1pc.	3m, D-SUB 9 pin For expansion serial I/F at expansion option box(CR1-EB3).

Note1)The personal computer cable is the same as that for use with "Movemaster M1/M2/E/EN series".

Specifications

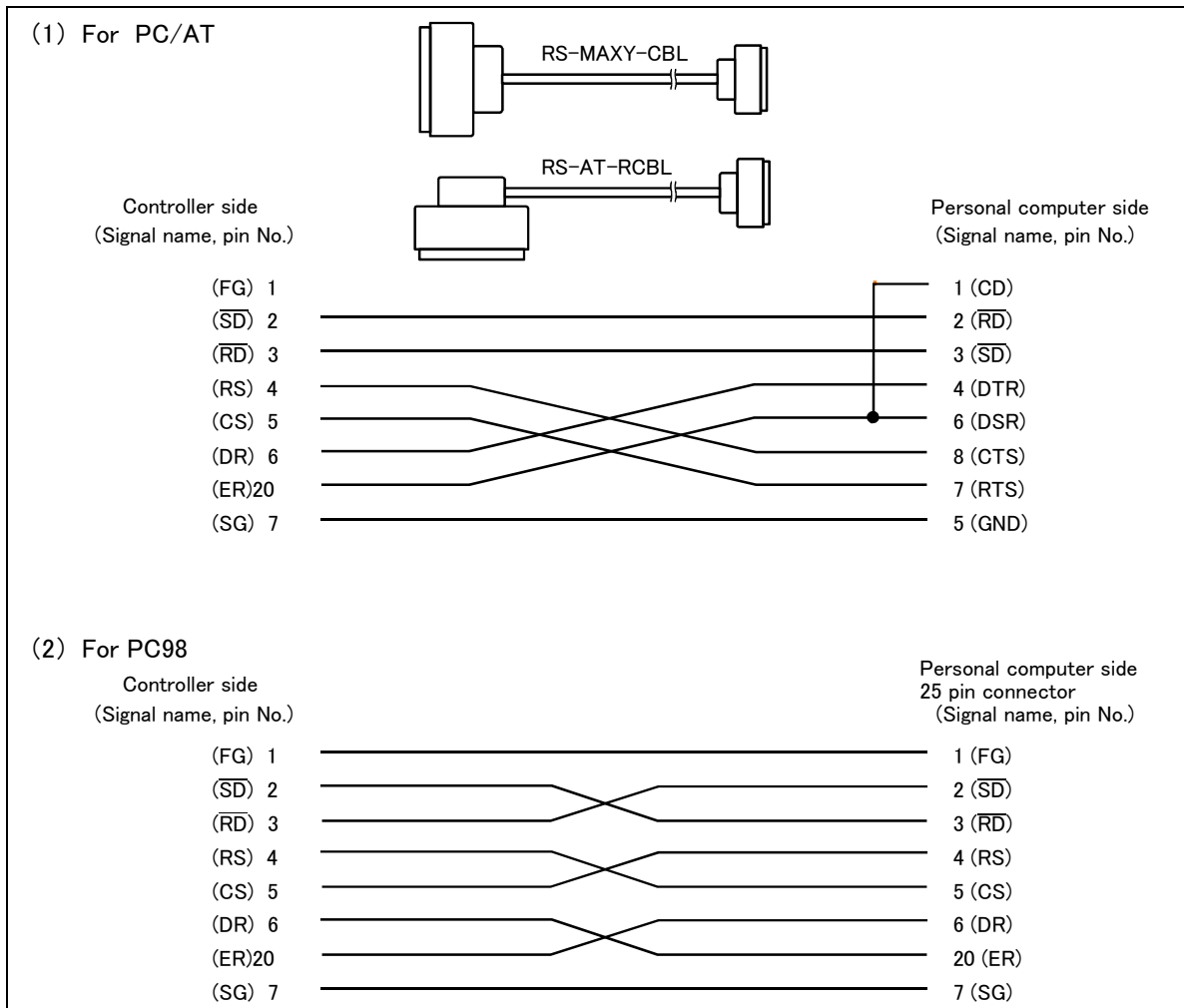

Fig.3-31 : Personal computer cable connection

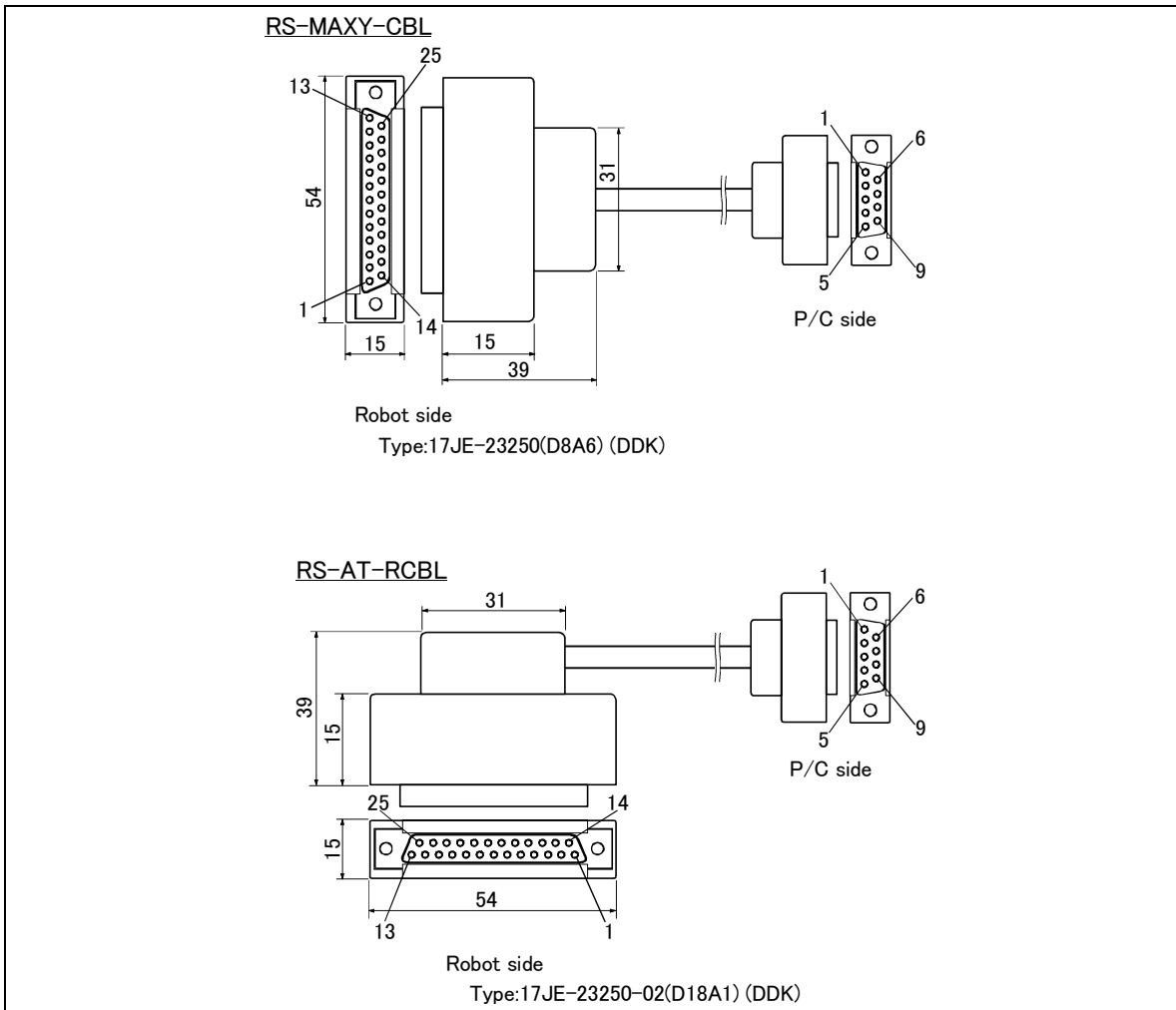
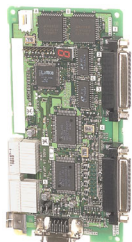

Fig.3-32 : Personal computer cable connector

(8) Extended serial interface

■ Order type: ● 2A-RZ581-E

■ Outline



The extension serial interface is the option to add a serial communication function to the robot controller. One channel of RS-232C interface is provided in the front of the controller. By using the extension serial interface, more channels can be added in order to allow the use of a personal computer, vision sensor and PLC at the same time. Also, in addition to RS-232C communication, RS-422 communication, which is superior in noise resistance, is also supported.

The extended option box (CR1-EB3) is required separately(CR1-571 controller only). Refer to Page 70, "(4) Expansion option box" for details.

Caution) This option can only be used with the robot controller's main unit software version E1 or later.

■ Configuration

Table 3-32 : Configuration device

Part name	Type	Qty.	Remarks
Extended serial interface	2A-RZ581-E	1	
Instruction Manual	BFP-A8106	1	
Ferrite core	E04SR301334	2	Be sure to install this for noise countermeasure.

Table 3-33 : Procured by the customer

Part name	Type	Qty.	Remarks
Personal computer, vision sensor, etc.		From 1 unit.	Two channel per one board.
Communication cable (used when the length of the standard RS-232C cable is too short, or when RS-422 communication is implemented)	RS-232C or RS-422	From 1 cable.	

■ Specifications

Table 3-34 : Specifications

Item	Specifications	Remarks
Mountable optional slots	Slot 1 or 2	
Number of mountable interface cards	Maximum 2	
Number of channels	2	Channel 1: Dedicated to RS-232C Channel 2: Either RS-232C or RS-422
Communication data	ASCII data ^{Note1)}	
Communication baud rate	2400 / 4800 / <u>9600</u> / 19200	This has been set to "9600" at shipment.
Parity	Notiong / Odd/ <u>Even</u>	This has been set to "even" at shipment.
Stop bit	1 / <u>2</u>	This has been set to "2" at shipment.
End code	<u>CR code</u> / CR code + LF code	This has been set to "CR code" at shipment.
Protocol	<u>Nonprocedural</u> / Procedural / Data link ^{Note2)}	This has been set to "nonprocedural" at shipment.
Remarks	Capable of offering the same functions as provided by the standard RS-232C interface in the front of the controller	

Note1) Binary data communication is not supported.

Note2) Nonprocedural: Nonprocedural protocol with the personal computer support software

Procedural: Procedural protocol with the personal computer support software

Data link: Nonprocedural (ASCII data) protocol for data link between robot programs and a personal computer/PLC/vision sensor, etc.

■ Functions

(1) Controller communication function

- This function allows to update and download programs as well as to monitor various statuses.
- The personal computer support software (sold separately) is available as a robot controller programming support tool. Refer to (9), [Page 96](#), "(13) Personal computer support software/Personal computer support software mini" of details.

(2) Data link function

- The data link function allows to link numerical values and position data between robot programs and a personal computer using the MELFA-BASIC IV language (OPEN/PRINT/INPUT instruction).
- Data can be exchanged one to one by specifying the COM number at the communication open destination.

■ Pin assignment

(1) RS-232C pin assignment

Refer to [Page 84](#), "(7) Personal computer cable".

(2) RS-422 pin assignment

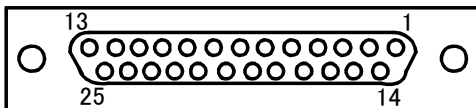

Fig.3-33 : D-SUB25 Pin Female Connector (RZ581 Board Side)

Pin no.	Abbreviated signal name	Signal name	Signal direction 2A-RZ581 ↔ Device on other end
1	FG	Frame ground	—————
7, 9	SG	Signal ground	—————
13	TXD+(SDA)	Transmission data (+)	—————→
25	TXD-(SDB)	Transmission data (-)	—————→
11	DTR+(RSA)	Terminal ready (+)	—————→
23	DTR-(RSB)	Terminal ready (-)	—————→
12	RXD+(RDA)	Reception data (+)	←————
24	RXD-(RDB)	Reception data (-)	←————
10	DSR+(CSA)	Data set ready (+)	←————
22	DSR-(CSB)	Data set ready (-)	←————

(9) CC-Link interface

■ Order type: ● 2A-HR575-E

■ Outline

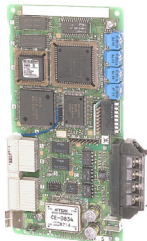

The CC-Link interface is the option to not only add bit data to the robot controller, but also to add CC-Link field network function that allows cyclic transmission of word data.

The extended option box (CR1-EB3) is required separately (CR1-571 controller only). Refer to Page 70, "(4) Expansion option box" for details.

Caution) This option can only be used with the robot controller's main unit software version E1 or later.

■ Configuration

Table 3-35 : Configuration device on

Part name	Type	Qty.	Remarks
CC-Link interface	2A-HR575-E	1	
Instruction Manual	BFP-A8105	1	
Ferrite core	E04SR301334	2	Be sure to install this for noise countermeasure.

Table 3-36 : Procured by the customer

Part name	Type	Qty.	Remarks
Master station	QJ61BT11(Q series)	1	FX series products are not supported.
	AJ61QBT11(QnA series)		
	A1SJ61QBT11(QnAS series)		
	AJ61BT11(A series)		
	A1SJ61BT11(AnS series)		
	A80BD-J61BT11(personal computer board)		
Communication cable	-	1	Shielded 3-core twisted cable This cable may be manufactured by the customer.
Terminal resistor	-	1	110Ω or 130Ω is recommended.

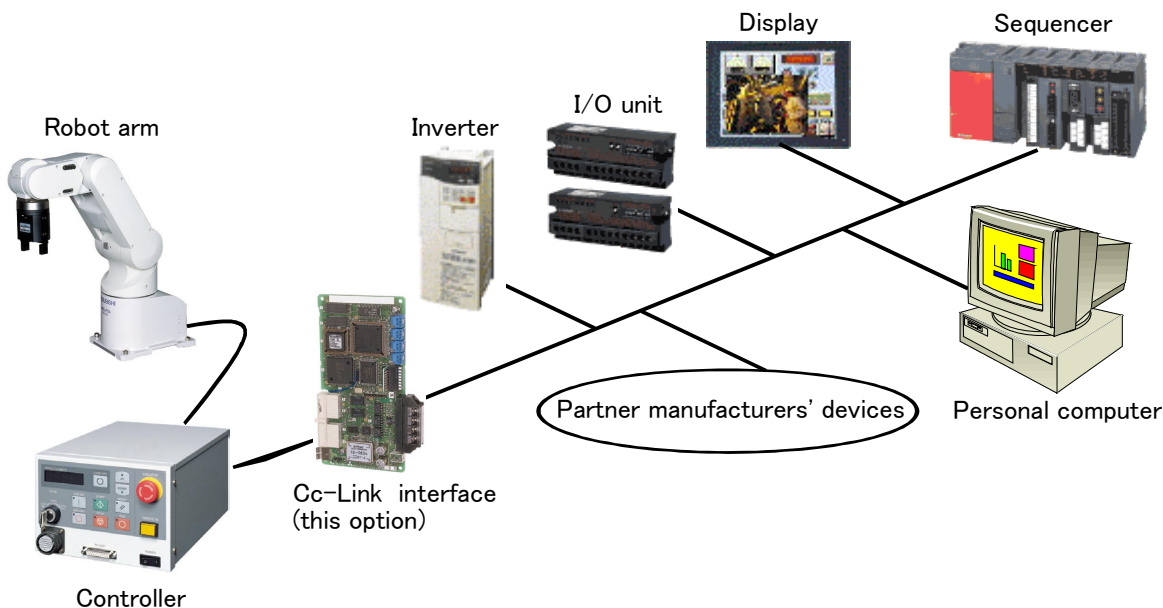

Fig.3-34 : Example of CC-Link Product Configuration

■ Specifications

Table 3-37 : Specifications

Item		Specifications		Remarks	
Communication function		Bit data and word data can be transmitted.		Word data are used by the registers.	
Station type		Intelligent device station ^{Note1)}			
Support station		Local station		No master station function	
Mountable option slot		Slot 2 only			
Number of mountable CC-Link interface cards		1		Multiple CC-Link interface cards cannot be inserted. ^{Note2)}	
Number of stations		1 to 64 stations		When four stations are occupied, continuous station numbers are used. The station numbers are set by a DIP switch.	
Transmission speed		10M/5M/2.5M/625K/156K bps		This is set by the rotary SW.	
Number of occupied stations		One or four occupied stations can be set.		When four stations are occupied, continuous station numbers are used. The station numbers are set by a DIP switch.	
Number of I/O points	Remote I/O	When one station is occupied	Input: 30 points	Output: 30 points	The last two points of 32 points cannot be used.
		When four stations are occupied	Input: 126 points	Output: 126 points	The last two points of 128 points cannot be used.
	Remote registers	When one station is occupied	Input: 4 registers	Output: 4 registers	One register consists of 16 bits.
		When four stations are occupied	Input: 16 registers	Output: 16 registers	

Note1)The CC-Link interface supports neither the transient transmission function nor the FX series.

Note2)This product cannot be used together with a PROFIBUS interface card.

■ Functions

(1) Communication function

- The number of usable points is 126 points maximum for bit control and 16 points maximum for word control.
- Up to 2,048 points of input bit data can be monitored by a unit being connected. (Input only, output is disabled.)
- Up to 256 points of input word data can be monitored by a unit being connected. (Input only, output is disabled.)

(2) Easy setup

- The CC-Link interface card can be set by a rotary switch or DIP switch.
- No separate space is required to mount the CC-Link interface card as it is embedded in the robot controller (can only be mounted into slot 2).
- Easy wiring since only four terminals need to be connected.
- Dedicated commands have been added to MELFA-BASIC IV (robot programming language); thus, no complex interface programming is required.

(3) High-speed response

- The link scan time when connecting 64 stations is approximately 7.2 ms, achieving superior high-speed response performance.
- A transmission speed can be selected from 10M, 5M, 2.5M, 625K and 156K bps according to the transmission distance.

(10) Ethernet interface

■ Order type: ● 2A-HR533-E

■ Outline

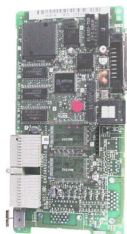

The Ethernet interface is the option to add an Ethernet communication function to the robot controller.

The extended option box (CR1-EB3) is required separately(CR1-571 controller only). Refer to Page 70, "(4) Expansion option box" for details.

Caution) This option can only be used with the robot controller's main unit software version E2 or later.

Also, compatible version differs for each function(CR1-571 controller only). Refer to "Table 3-42: Software Versions and Functions of the Controller" for details.

■ Configuration

Table 3-38 : Configuration device on

Part name	Type	Qty.	Remarks
Ethernet interface	2A-HR533-E	1	
Instruction Manual	BFP-A8108	1	
Ferrite core	E04SR301334	1	Be sure to install this for noise countermeasure.

Table 3-39 : Procured by the customer

Part name	Type	Qty.	Remarks
Personal computer (A network interface is required.)	Windows 95/98/Me/NT 4.0/2000/XP compatible. Installed with TCP/IP network functions, including Linux OS (However, operation has not be verified.)	From 1 unit.	
Ethernet cable (Select either straight cable or cross cable depending on the connection mode.)	10BASE-T or 10BASE-5	From 1 cable.	

Table 3-40 : Items required as needed

Part name	Type	Qty.	Remarks
Hub (Required for use in LAN environment)	(Commercially sold)	1	
Windows compatible robot controller programming support tool for Mitsubishi CRn-500 series controllers	(Separately sold) Personal computer support software	1	
Windows compatible development tool	(Commercially sold) Microsoft Visual C++, Visual Basic, etc.	1	

■ Specifications

Table 3-41 : Specifications

Item	Specifications	Remarks
Mountable optional slots	Slot 1 only	
Number of mountable interface cards	1	
LAN interface	10BASE-T or 10BASE-5(changeover type)	
Transmission speed	10Mbps	
Connector specification	RJ-45	

A personal computer and the robot controller that communicates with that personal computer must be located on the same network. They cannot communication with each other crossing a firewall (from the Internet) or gateway (from another adjacent network, etc.). If such form of communication must be implemented, consider communicating via a server connected to the same network as that of the robot controller. Be cautious about safety and response performance in this case.

■ Functions

(1) Controller communication function

- This function allows communication with the robot controller via Ethernet.
(Program upload/download, status monitoring, etc.)

The personal computer support software (sold separately) is available as a robot controller programming support tool.

- This function allows communication with a maximum of 16 clients on other end.

(2) Data link function

- The data link function allows to link numerical values and position data between robot programs and a personal computer using the MELFA-BASIC IV language (OPEN/PRINT/INPUT instruction).
- Data can be exchanged one to one by specifying the COM number at the communication open destination.
- This function allows to communicate with up to eight applications of clients on other end by changing COM numbers.
- Either server mode or client mode can be selected as the TCP/IP function.
- The customer needs to write application programs on the personal computer side.

(3) Real-time external control function

- The real-time external control function loads the position command data and performs operation in control cycle units of the robot. The joint, orthogonality and motor pulse can be specified as the position data. Also, this function monitors I/O signals and outputs signals at the same time.
- The data that can be monitored include the encoder feedback values, current command, and current feedback of the position data type mentioned above.
- This function is valid only for the following models:
 - RP-1AH/3AH/5AH series
 - RV-1A series
 - RV-2A/3AJ series
 - RV-4A/5AJ/3AL/4AJL series
 - RH-5AH/10AH/15AH series
 - RV-6S/6SL/12S/12SL series
 - RV-3S/3SJ/3SB/3SJB series
- In order to control the robot, an application program on the personal computer side must be created by the customer. It must communicate one to one.

Table 3-42 : Software Versions and Functions of the Controller

Software version of the robot controller	Controller communication function	Data link function (server)	Data link function (server/client)	Real-time external control function
Versions A*, B*, C*, D* and E1	The Ethernet option is disabled.			
Versions E2 to E4	○	○	×	×
Versions F*, G* and H1 to H6	○	○	×	○
Versions H7 and later	○	○	○	○

○ Can be used.
 × Cannot be used.

(11) Additional axis interface

■ Order type: ● 2A-RZ541-E

■ Outline

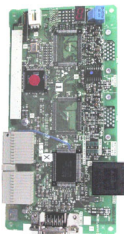

The additional axis interface is an interface, which uses the general-purpose servo amplifier of Mitsubishi and the corresponding servomotors in order to allow the plural above servomotors to be controlled from the robot controller.

The extended option box (CR1-EB3) is required separately (CR1-571 controller only). Refer to Page 70, "(4) Expansion option box" for details.

Caution) Additional axis interface can be used with a robot controller software version of G9 or later.

Servo systems that can be used with the additional axis interface are shown in Table 3-43.

Table 3-43 : Applicable servo systems

Servo amplifier name	Type	Maker name
MELSERVO-J2-Super series ^{Note1)}	MR-J2S- □ B (ABS must be designated.)	Mitsubishi Electric

Note1) The J2-Super Series servo amplifiers, use the servo amplifiers with software version of B0 or later.

■ Configuration

Table 3-44 : Configuration device on

Part name	Type	Qty.	Remarks
Additional interface	2A-RZ541-E	1	
Instruction Manual	BFP-A8107	1	
Ferrite core	E04SR301334	2	Be sure to install this for noise countermeasure.

The products necessary in addition to the additional axis interface are listed in Table 3-45. For these main products, refer to "Instruction Manual for Servo Amplifier and Servomotor".

Table 3-45 : Procured by the customer

Part name	Type	Qty.	Remarks
Servo amplifier, servomotor, option, peripheral device	Refer to "Instruction Manual for Servo Amplifier and Servomotor".	-	
Battery (for absolute position detection system)	MR-BAT or A6BAT	Amplifier quantity	
Setup software (For setup the parameter of servo amplifier and the graph indication, etc.)	MRZJW3-SETUP131 if the MELSERVO-J2-Super is used. MRZJW3-SETUP41 or later if the MELSERVO-J2-B is used.	1	
Communication cable (Communication cable between personal computer and servo amplifier for setup software)	MR-CPCATCBL3M	1	
Bus cable between controller and amplifier (Exclusive cable for communication between controller and servo amplifier)	MR-J2HBUS □ M (Cable length in : 0.5, 1 and 5 [m]) Note) The MR-J2HBUS □ M-A can't be used, caution.	1	
Terminator	MR-A-TM	1	
Bus cable between amplifier and amplifier (Exclusive cable for communication between servo amplifier and servo amplifier)	MR-J2HBUS □ M (Cable length in : 0.5, 1 and 5 [m])	Amplifier quantity-1	

■ Specifications

Table 3-46 : Specifications

Item	Specifications	Specification of user mechanism
Number of controllable robots (mechanisms)	3	
Number of control axes (total)	8 axes	
Number of control axes (for each mechanism)	2 axes	3 axes
Applicable amplifier	MELSERVO-J2-Super series	
Applicable encoder	ABS method only (absolute value encoder)	
Communication method	SSCNET (differential communication) of Mitsubishi	
Mountable optional slots	Slot 1 or 3	
Number of mountable interface cards	1	
Control function	Synchronous interpolation control	
Path control method	CP control/PTP control	PTP control
Acceleration/deceleration	The trapezoidal method/acceleration/deceleration time pattern can be set.	
Position control	Distance control/angle control can be selected. Actual value control with pitch/deceleration ratio setting	
Minimum command value	0.01mm or 0.001mm (can be changed by a parameter)	
Maximum motion range	Max. .80000.00(0) deg. to +80000.00 (0) deg.	

■ Functions

(1) Additional robot axis function

- The robot controller can control a maximum of 2 axes such the travel axis, etc., as the 7th and 8th axes of the robot arm.
- Additional axes are controlled in such a way that they start moving and stop simultaneously with the standard robot axes.

(2) Multi-mechanism function

- The robot controller can control user-created mechanisms, such as a rotation axis and a linear driving axis, for up to 2 units as multi-mechanisms.
- The robot controller controls multi-mechanisms independent of the standard robot axes (asynchronous control). It can control up to 3 axes of user-created mechanisms per unit.

(3) Programming language

- The additional axes can be programmed with MELFA-BASICIV language method and MOVEMASTER command method.
- User-created mechanisms can only be controlled using the MELFA-BASIC IV language.

(12) Extension memory cassette
(CR2B-574 controller only)

■ Order type: ● 2A-HR432

■ Outline



Used to increase the total number of teaching points in the robot program.

■ Configuration

Table 3-47 : Configuration device

Part name	Type	Qty.	Remarks
Extension memory cassette	2A-HR432	1	27,900 total teaching points With a battery backup feature

■ Specifications

Table 3-48 : Specifications

Items	Specifications	Remarks
External dimensions	Approx. 95(W)X65(D)X15(H) mm	Excluding the connection connector
Mass	Approx. 0.2 kg	
Connection method	Connection using a special connector	
Memory size ^{Note1)}	Teaching point number: 25,400 Steps number: 50,800 Program number: 100	The battery backup function is provided. Together with 2,500 points of standard teaching positions, the total number of teaching positions is 27,900 points.
Backup	Backup using the controller's internal battery	

Note1) As for the standard 2,500 points, after adding an expansion memory cassette, the information in all backup memory areas in the controller is copied into the expansion memory cassette. Therefore, please note that if the expansion memory cassette is removed after it has been added, there will be no program left in the controller.

[CAUTION]

- Inserting and removing the memory cassette
A memory cassette cannot be inserted or removed while the control power is on. Please turn off the control power before handling the memory cassette to avoid destroying the memory information in the cassette.
- Memory backup
Retaining the contents of memory in a memory cassette is not covered by the warrantee when the memory cassette is removed from the control unit. Nonetheless, memory is retained under the following conditions.
(Conditions) If the power has been on for at least a half-hour before the power is turned off and the cassette is removed, the contents of memory can be retained for approximately one hour. (Not covered by the warrantee.)

■ Installation

The installation method to the CR2B-574 controller is shown below.

- 1) Completely back up the memory information in the robot controller using the personal computer support software. (This must be performed as a preventive measure in case the contents of the internal memory are destroyed while inserting a memory cassette.)
- 2) Turn off the controller power.
- 3) Remove the dust-proof cover installed in the rear of the controller.
- 4) Install the attached fixing plate of memory cassette with the screw which fixed the dust-proof cover.
- 5) Attach a memory cassette to the controller.

- As shown in Fig. 3-35, insert the memory cassette all the way to the back with the "▲" facing up.
- Securely tighten the fixing screws.

Note) Be careful not to over-tighten the screws, as it may deform the memory cassette.

- 6) Turn on the controller power.

Error C.0023 will occur when using the software version J1 edition.

Press the reset button to clear the error.

At this point, a new file system has been created in the memory cassette.

[CAUTION]

The programs that are stored in the control unit will be copied into the memory cassette; they will be deleted from the memory in the control unit. Please be careful not to remove the memory cassette, since if you remove it, there will be no program information residing in the controller (the information is in the memory cassette).

Although the program information (****.MB4) is copied into the memory cassette, the parameter information (****.PRM) is still stored in the control unit.

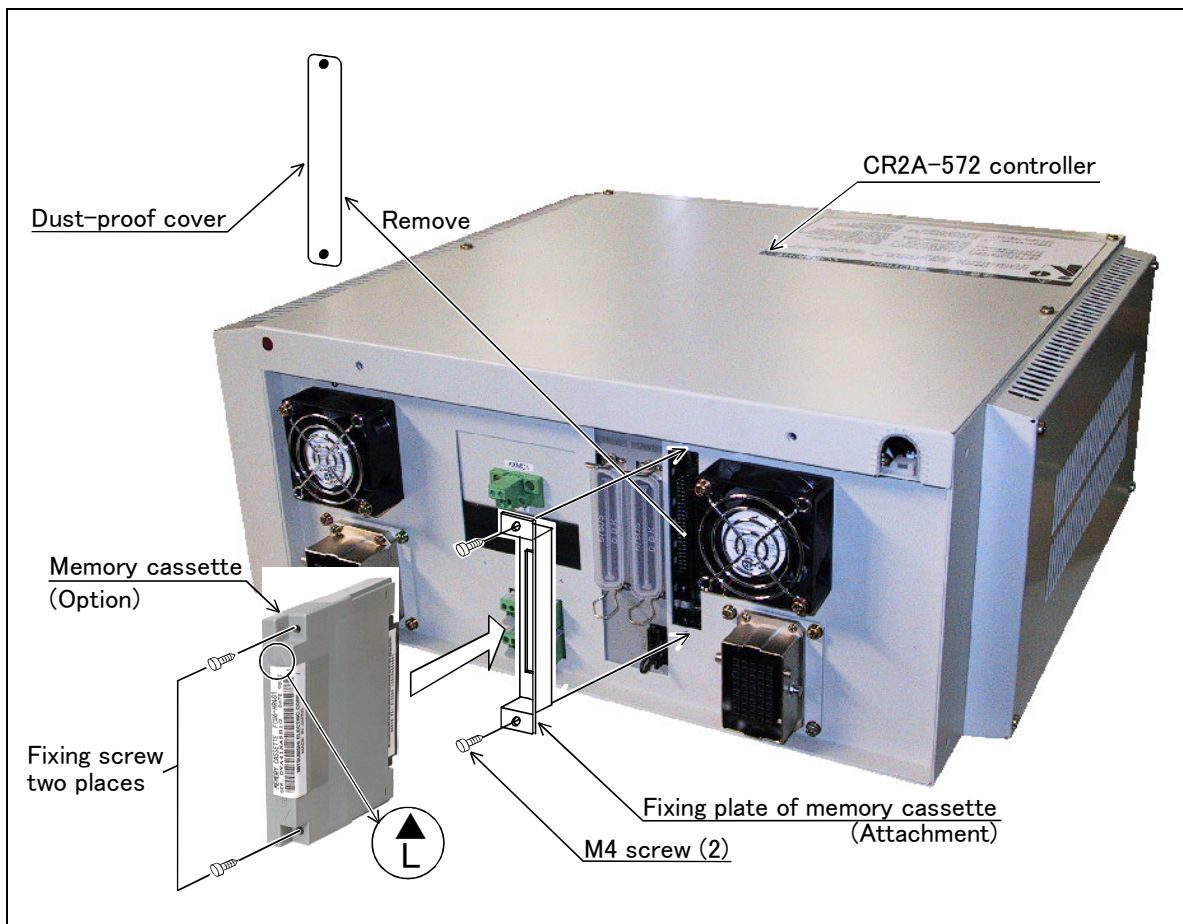

Fig.3-35 : Installation method of extension memory cassette

(13) Personal computer support software/Personal computer support software mini

- Order type :
 - Personal computer support software
 - *For windows CD-ROM : 3A-01C-WINE
 - Personal computer support software mini
 - *For windows CD-ROM : 3A-02C-WINE

■ Outline



This is handy software that fully uses the personal computer functions. It can be used in various stages from the robot specifications study (tact study, etc.) to the design support (creation and editing of programs), start up support (execution, control and debugging of program), and maintenance (remote maintenance.)

The "personal computer support software" which supports these function fully, and the "personal computer support software mini" which does not have the simulation function are available. Select according to the required application.

■ Configuration

Table 3-49 : Product configuration

Part name	Type	Medium	Remarks
Personal computer support software	3A-01C-WINE	CD-ROM	One operation manual included
Personal computer support software mini	3A-02C-WINE	CD-ROM	One operation manual included

■ Features

- (1) Simple operation with guidance method and menu method

The Windows standard is used for windows operation, so the controller initialization and startup operations can be carried out easily by following the instructions given on the screen. Even a beginner can easily carry out the series of operations from program creation to execution.
- (2) Increased work efficiency with ample support functions

The work efficiency is greatly improved with the multi-window method that carries out multiple steps and displays in parallel. The renumbering function, and copy, search, syntax check and step execution are especially sufficient, and are extremely useful when editing or debugging the program.

With the simulation function support, the program can be debugged and the tact checked before starting the machine at the site. This allows the on-site startup work efficiently to be greatly improved.
- (3) Increased maintenance efficiency with remote maintenance function

With remote operations over a telephone line, the robot's operation status can be monitored without going to the site. Losses incurred while moving to the site can be reduced, and the time required to investigate the trouble and determine measures to be taken can be shortened.
- (4) The maintenance forecast function increases the efficiency of maintenance work. Analyze the load condition while the robot is actually operating. Based on this analysis, calculate the time for maintenance, such as lubrication and belt replacement. By utilizing this information, the line stop time as well as the maintenance costs can be reduced.

Note) The maintenance forecast function is supported by Personal Computer Support Software Version E1 or later.
- (5) The position recovery support function increases the recovery efficiency in the event of origin position displacement. This function compensates the origin settings and position data by just reproducing several previous teaching points when hand and/or arm displacement occurs, when replacing the motor and the belts, or when reloading the robot. This function can reduce the time required for recovery.

Note) The position recovery support function is supported by Personal Computer Support Software Version F1 or later.

■ Functions

Table 3-50 : Functions

Function		Functional existence ^{Note1)}		Details
Compatible model		○	○	Personal computer running Microsoft Windows98/2000/NT 4.0/Me/XP.
Program editing functions	Editing functions	○	○	<ul style="list-style-type: none"> • MELFA BASIC IV language compatible • Multiple editing screen simultaneously display • Command input, comment writing • Position data editing • File operation (writing to controller, floppy disk, personal computer) • Search and replace function (using characters, line Nos., labels) • Copy, cut, paste, insert (per character, line), undo (per command statement, position conversion) • Line No. automatic generation, renumbering • Batch syntax check • Command template • Position conversion batch editing • Position variable template • Print, print preview
	Control functions	○	○	<ul style="list-style-type: none"> • Program file control (list, copy, movement, delete, content comparison, name change, protect)
	Debugging functions	○	○	<ul style="list-style-type: none"> • Direct editing of program in controller • Confirmation of robot program operation (step execution, direct execution) • Tact time measurement^{Note2)}
Simulation function ^{Note3)}		○	×	<ul style="list-style-type: none"> • Off-line simulation of robot program operation using CG (computer graphics) • Tact time calculation
Monitor functions		○	○	<ul style="list-style-type: none"> • Robot operation monitor (robot operation state, stop signal, error monitor, program monitor (execution program, variables), general-purpose input/output signals (forced output possible), dedicated input/output signals, operation confirmation (operation range, current position, hand, etc.) • Operation monitor (working time statistics, production information, robot version) • Servo monitor (position, speed, current, load, power)
Maintenance function		○	○	<ul style="list-style-type: none"> • Parameter setting • Batch, divided backup
Remote maintenance function		○	○	<ul style="list-style-type: none"> • Monitoring and maintenance of robot state at remote site using telephone line. (A separate modem is required for this function.)

○ Personal computer support software mini (3A-02C-WINE)
 ○ Personal computer support software (3A-01C-WINE)

Note1)The functions included with the personal computer support software and the personal computer support software mini are shown below. ○ : Function provided × : Function not provided

Note2)When using the "personal computer support software mini", connect with the controller and measure.

Note3)A simulation function is available only with "MELFA-BASIC IV".

(14) Instruction Manual(bound edition)

- Order type : ● 4S-MAP-106 : In the case of CR1B-571 controller
- 4S-MAP-104 : In the case of CR2B-574 controller

■ Outline



This is a printed version of the CD-ROM (instruction manual) supplied with this product.

■ Configuration

Table 3-51 : Product configuration

Part name	Type	Specifications
Instruction Manual(CR1B-571 controller version)	4A-MAP-106	Instruction manual set for the CR1B-571 controller
Safety Manual	BFP-A8006	Items relating to safety in handling the robot
Standard Specifications	BFP-A8408	Specification of the robot arm and controller
Robot Arm Setup & Maintenance	BFP-A8388	Installation method of the robot arm, jog operation, and maintenance and inspection procedures
Controller Setup, Basic Operation and Maintenance	BFP-A8054	Installation method of the controller, basic operation, and maintenance and inspection procedures
Detailed Explanation of Functions and Operations	BFP-A5992	Functions of the controller and T/B, operation method, and explanation of MELFA-BASIC IV
Troubleshooting	BFP-A5993	Causes of errors occurred and their countermeasures
Explanations of MOVEMASTER COMMANDS	BFP-A8056	Explains details of the MOVEMASTER commands
Instruction Manual(CR2B-574 controller version)	4A-MAP-104	Instruction manual set for the CR2B-574 controller
Safety Manual	BFP-A8006	Items relating to safety in handling the robot
Standard Specifications	BFP-A8408	Specification of the robot arm and controller
Robot Arm Setup & Maintenance	BFP-A8388	Installation method of the robot arm, jog operation, and maintenance and inspection procedures
Controller Setup, Basic Operation and Maintenance	BFP-A5991	Installation method of the controller, basic operation, and maintenance and inspection procedures
Detailed Explanation of Functions and Operations	BFP-A5992	Functions of the controller and T/B, operation method, and explanation of MELFA-BASIC IV
Troubleshooting	BFP-A5993	Causes of errors occurred and their countermeasures
Explanations of MOVEMASTER COMMANDS	BFP-A8056	Explains details of the MOVEMASTER commands

3.9 Maintenance parts

The consumable parts used in the controller are shown in [Table 3-52](#). Purchase these parts from your dealer when required. Some Mitsubishi-designated parts differ from the maker's standard parts. Thus, confirm the part name, robot arm and controller serial No. and purchase the parts from your dealer.

Table 3-52 : Controller consumable parts list

No.	Part name	Type	Qty.	Usage place	Manufacturer
CR1B-571 controller					
1	Lithium battery	ER6	1	RZ182 card	Mitsubishi Electric System & Service;Co.,Ltd
2	Filter		1	Bottom of the controller	
CR2B-574 controller					
3	Lithium battery	ER6	1	Control unit	Mitsubishi Electric System & Service;Co.,Ltd
4	Filter		1	Bottom of the controller	

Note1) Confirm the robot arm serial No., and contact the dealer or service branch of Mitsubishi Electric Co., for the type.

4 Software

4.1 List of commands

The robot language to use can choose "MELFA-BASIC IV" (default setting) or "MOVEMASTER language (MOVEMASTER commands)" by changing the parameter.

Use of "MELFA-BASIC IV" is recommended to effectively use this controller's functions.

The available new functions in MELFA-BASIC IV are given in [Table 4-1](#).

Table 4-1 : The available new functions in MELFA-BASIC IV

Class	Command example	Function
Robot Status Variable	P_TOOL	keep current tool length
	M_SPD	keep current speed (linear/circular interpolation)
Built-in functions	ABS	Produces the absolute value
	VAL	Converts a character string into a numeric value
	ATN	Calculates the arc tangent
	STR\$	Converts the numeric expression value into a decimal character string
	ZONE	Check current position area
Operation function	P1=P1*P2	Relative calculation of position data
	M1=M1*M2	Multiplication of numerical variable
	P1.X=10	Operation of the position element data
Conditional branching	SELECT CASE	More than one condition branch
	ON GOSUB	Condition branch by the value
	WHILE WEND	Repeat with condition
Optimum acceleration/ deceleration control	LOADSET	Load condition setting
	OADL	valid/invalid setting for the optimum acceleration/deceleration
Float control (compliance in the XYZ coordinate system)	CMP POS	Compliance control
	CMPG	Force control
Parallel execution (Multitask)	XRUN, XSTP, XRST, XLOAD, XCLR	Parallel executions of another task, the stops, the resets the clear, and, the loads
Conveyor trucking [Special specification]	TRKON, TRKOFF	Valid/invalid of the trucking
	TRBASE	Setting the base coordinate for the trucking
Impact detection	COLCHK	Set to enable/disable the impact detection.
	COLLVL	Set the detection level of the impact detection.
Singular point passage	MVS P1 TYPE 0,2	Pass a singular point using linear interpolation.

(1) The procedure of robot language selection

Table 4-2 : Robot language parameter

Parameter	Parameter name	No. of arrays No. of characters	Details explanation	Factory setting
Robot language	RLNG	Integer 1	Select the robot language to use 1 : MELFA-BASIC IV 0 : MOVEMASTER COMMAND	1

Note 1) "MELFA-BASIC IV" is default setting.

Note 2) Refer to the separate manual "Explanation of MOVEMASTER COMMANDS"(BFP-A8056) for details of "MOVEMASTER COMMAND".

(2) MELFA-BASIC IV commands

Table 4-3 : List of MELFA-BASIC IV commands

Type	Class	Function	Input format (example)
Position and operation control	Joint interpolation	Moves to the designated position with joint interpolation.	MOV P1
	Linear interpolation	Moves to the designated position with linear interpolation.	MVS P1
	Circular interpolation	Moves along a designated arc (start point → passing point → start point (end point)) with 3-dimensional circular interpolation (360 degrees).	MVC P1,P2,P1
		Moves along a designated arc (start point → passing point → end point) with 3-dimensional circular interpolation.	MVR P1,P2,P3
		Moves along the arc on the opposite side of a designated arc (start point → reference point → end point) with 3-dimensional circular interpolation.	MVR2 P1,P9,P3
		Moves along a set arc (start point → end point) with 3-dimensional circular interpolation.	MVR3 P1,P9,P3
	Speed designation	Designates the speed for various interpolation operations with a percentage (0.1% unit).	OVRD 100
		Designate the speed for joint interpolation operation with a percentage (0.1% unit).	JOVRD 100
		Designates the speed for linear and circular interpolation with a numerical value (mm/s unit).	SPD 123.5
		Designates the acceleration/deceleration time as a percentage in respect to the predetermined maximum acceleration/deceleration. (1% unit)	ACCEL 50,80
		Automatically adjusts the acceleration/deceleration according to the parameter setting value.	OADL ON
		Sets the hand and work conditions for automatic adjustment of the acceleration/deceleration.	LOADSET 1,1
	Operation	Adds a process unconditionally to the operation.	WTH
		Adds a process conditionally to the operation.	WTHIF
		Designates smooth operation.	CNT 1,100,200
		Designates the positioning completion conditions with a No. of pulses.	FINE 200
		Turns the servo power ON/OFF for all axes.	SERVO OFF
		Limits the operation of each axis so that the designated torque is not exceeded.	TORQ 4,10
	Position control	Designates the base conversion data.	BASE P1
		Designates the tool conversion data.	TOOL P1
	Float control	The robot arm rigidity is lowered and softened. (XYZ coordinate system)	CMP POS ,&B00000011
		The robot arm rigidity is lowered and softened. (TOOL coordinate system)	CMP TOOL ,&B00000011
		The robot arm rigidity is returned to the normal state.	CMP OFF
		The robot arm rigidity is designated.	CMPG 1.0,1.0,1.0,1.0,1.0,1.0,1.0
	Pallet	Defines the pallet.	DEF PLT 1,P1,P2,P3,P4,5,3,1
		Operates the pallet grid point position.	PLT 1,M1
	Singular point passage	Move to a specified position using linear interpolation passing through a singular point.	MVS P1 TYPE 0,2
	Branching	Branches unconditionally to the designated place.	GOTO 120
		Branches according to the designated conditions.	IF M1=1 THEN GOTO 100 ELSE GOTO 20 END IF
		Repeats until the designated end conditions are satisfied.	FOR M1=1 TO 10 NEXT M1
		Repeats while the designated conditions are satisfied.	WHILE M1<10 WEND
		Branches corresponding to the designated expression value.	ON M1 GOTO 100,200,300
		Executes program block corresponding to the designated expression value..	SELECT CASE 1 BREAK CASE 2 BREAK END SELECT
		Moves the program process to the next line.	SKIP
	Impact detection	Set to enable/disable the impact detection.	COLCHK ON/OFF
		Set the detection level of the impact detection.	COLLVL 100,80,.....

Type	Class	Function	Input format (example)
Program control	Subroutine	Executes the designated subroutine. (Within program)	GOSUB 200
		Returns from the subroutine.	RETURN
		Executes the designated program.	CALLP "P10",M1,P1
		Defines the program argument executed with the CALLP command.	FPRM M10,P10
		Executes the subroutine corresponding to the designated expression value.	ON M1 GOSUB 100,200,300
	Interrupt	Defines the interrupt conditions and process.	DEF ACT 1, M1=1 GOTO 100
		Enables/disables the interrupt.	ACT 1=1
		Defines the start line of the program to be executed when an interrupt is generated from the communication line.	ON COM(1) GOSUB 100
		Enables the interrupt from the communication line.	COM(1) ON
		Disables the interrupt from the communication line.	COM(1) OFF
		Stops the interrupt from the communication line.	COM(1) STOP
	Wait	Designates the wait time, and the output signal pulse output time. (0.01s unit)	DLY 0.5
		Waits until the variable becomes the designated value.	WAIT M_IN(1)=1
	Stop	Stops the program execution.	HLT
Generates an error. During program execution, continue, stop or servo OFF can be designated.		ERROR 9000	
End	Ends the program execution.	END	
Hand	Hand open	Opens the designated hand.	HOPEN 1
	Hand close	Closes the designated hand.	HCLOSE 1
Input/output	Assignment	Defines the input/output variables.	DEF IO PORT1=BIT,0
	Input	Retrieves the general-purpose input signal.	M1=M_IN (1)
	Output	Calls out the general-purpose output signal.	M_OUT(1) =0
Parallel execution	Mechanism designation	Acquires the mechanism with the designated mechanism No.	GETM 1
		Releases the mechanism with the designated mechanism No.	RELM 1
	Selection	Selects the designated program for the designated slot.	XLOAD 2,"P102"
	Start/stop	Carries out parallel execution of the designated program.	XRUN 3,"100",0
Stops parallel execution of the designated program.		XSTP 3	
	Returns the designated program's execution line to the head and enters the program selection enabled state.	XRST 3	
Others	Definition	Defines the integer type or real number type variable.	DEF INTE KAISUU
		Defines the character string variable.	DEF CHAR MESSAGE
		Defines the layout variable. (Up to 3-dimensional possible)	DIM PDATA(2,3)
		Defines the joint variable.	DEF JNT TAIHI
		Defines the position variable.	DEF POS TORU
		Defines the function.	DEF FNTASU(A,B)=A+B
	Clear	Clears the general-purpose output signal, variables in program, variables between programs, etc.	CLR 1
	File	Opens a file.	OPEN "COM1:" AS #1
		Closes a file.	CLOSE #1
		Inputs data from a file.	INPUT# 1,M1
		Outputs data to a file.	PRINT# 1,M1
	Comment	Describes a comment.	REM "ABC"
	Label	Indicates the branching destination.	*SUB1

4.2 List of parameters

(1) List of parameters

show the main parameter in the [Table 4-4](#).

Table 4-4 : List of parameters

Parameter		Details
Standard tool coordinates.	MEXTL	Set the default value for the tool data. Unit: mm or deg.
Standard base coordinates	MEXBS	Set the relation of the world coordinate system and robot coordinate system. Unit: mm or deg.
XYZ operation range	MEPAR	Designate the overrun limit value for the world coordinate system.
JOINT operation range	MEJAR	Set the overrun limit value for each joint axis.
Free plane limit		This is the overrun limit set with the free plane. Create a plane with the three coordinates x1, y1, z1 to x3, y3, z3, and set the outer side of the plane as the outside operation range (error). The following three types of parameters are used.
	SFC1P : SFC8P	Eight types of free plane limits can be set in SFC1P to SFC8P. There are nine elements, set in the order of x1, y1, z1, x2, y2, z2, x3, y3, z3.
	SFC1ME : SFC8ME	Designate which mechanism to use eight types of set free plane limits. The mechanism No. to use is set with 1 to 8.
	SFC1AT : SFC8AT	Set the validity of the eight types of set free plane limits. (Valid 1/Valid 2/invalid = 1/-1/0)
User-defined area		An area (cube) defined with two XYZ coordinate points can be designated and that area set as the outside operation range. Furthermore, a signal can be output when the axis enters that area. Up to eight types of area can be designated.
	AREA1P1 : AREA8P1	Designated the 1st point of the area. There are eight elements, set in the order of x, y, z, a, b, c, L1, L2. (L1 and L2 are the additional axes.)
	AREA1P2 : AREA8P2	Designated the 2nd point of the area. There are eight elements, set in the order of x, y, z, a, b, c, L1, L2. (L1 and L2 are the additional axes.)
	AREA1ME : AREA8ME	Designate which mechanism to use the eight types of set area. The mechanism No. to use is set with 1 to 8
	AREA1AT : AREA8AT	Designate the area check type. (Invalid/zone/interference = 0/1/2) Zone: The dedicated output signal USRAREA turns ON. Interference: An error occurs..
Automatic return setting	RETPATH	Set to restart the program after returning to the interrupt position when resuming operation after an interruption.
Buzzer ON/OFF	BZR	Designate whether to the turn buzzer ON or OFF.
Jog setting	JOGJSP	Designate the joint jog and step operation speed. (Set dimension H/L amount, max. override.)
	JOGPSP	Designate the linear jog and step operation speed. (Set dimension H/L amount, max. override.)
Jog speed limit value	JOGSPMX	Limit the operation speed during the teaching mode. Max. 250[mm/s]

Parameter		Details
Hand type	HANDTYPE	Set the hand type of the single/double solenoid, and the signal No. (Single/double = S/D) Set the signal No. after the hand type. Example) D900
Stop input B contact designation	INB	Change the dedicated input (stop) between the A contact and B contact.
User-designated origin	USERORG	Designate the user-designated origin position.
Program selection memory	SLOTON	Select the program selected previously when initializing the slot. The non-selected state will be entered when not set.
Communication setting	CBAU232	Set the baud rate.
	CLEN232	Set the character length.
	CPRTY232	Set the parity.
	CSTOP232	Set the stop bit.
	CTERM232	Set the end code.
Slot table	SLT1 : SLT32	Make settings (program name, operation type, order of priority, etc.) for each slot during slot initialization.
No. of multi-tasks	TASKMAX	Designate the No. of programs to be executed simultaneously. (Max. 32)
Select the function of singular point adjacent alarm	MESNGLSW	Designate the valid/invalid of the singular point adjacent alarm. (Invalid/Valid = 0/1) When this parameter is set up "VALID", this warning sound is buzzing even if parameter: BZR (buzzer ON/OFF) is set up "OFF".
Specification of singular point passage jog mode	FSPJOGMD	Specify an operation mode for singular point passage jog.
Display language. ^{Note1)} 表示言語 ^{Note1)}	LNG	Change the language to display on the LCD display of teaching pendant. ティーチングボックスの表示 LCD などに表示する言語を切り替えます。

Note1) The procedure of Language as shown in "(2) Change the display language / 表示言語の切り替え".

注 1) 表示言語切り替え方法の詳細を "(2) Change the display language / 表示言語の切り替え" に示します。

(2) Change the display language / 表示言語の切り替え

The language to display on the LCD display of teaching pendant can be changed by "the display language parameter". (Japanese or English)

Show the details of the parameter in the Table 4-4. Refer to the separate "Instruction Manual/Detailed Explanation of Functions and Operations" for details on changing the parameter.

The parameter is set up based on the order specifications before shipment. Order to dealer when the instruction manual of the other language is necessary.

More, the caution seals that stuck on the robot arm and the controller are made based on the language of the order specification. Use it carefully when selecting the other language.

表示言語設定パラメータによって、ティーチングボックスの表示 LCD などに表示する言語を切り替えることができます。(日本語、または英語) Table 4-4 にそのパラメータの詳細を示します。パラメータの変更方法は、別冊の「取扱説明書／機能と操作の詳細解説」を参照願います。

なお、出荷時にご注文仕様に基づき弊社で設定いたします。別の言語の取扱説明書をご希望の場合はご用命願います。

また、ロボット本体とコントローラに貼り付けてある注意シールは、ご注文仕様に基づいた言語で製作いたします。本パラメータを変更して言語を切り替えてご使用の場合はご注意願います。

Table 4-5 : Display language parameter / 表示言語設定パラメータ

Parameter パラメータ	Parameter name パラメータ名	No. of arrays No. of characters 配列数 文字数	Details explanation 内容説明	Default setting 出荷時 設定
Display lan- guage 表示言語設定	LNG	Character string 1 文字列 1	<p>Set up the display language. "JPN" : Japanese "ENG" : English</p> <p>The following language is changed. (1)The display LCD of teaching pendant. (2) Personal computer support software. *alarm message of the robot. *Parameter explanation list. (3)Alarm message that read from the robot with external communication. (Standard RS232C, Extended serial I/F, Ethernet I/F)</p> <p>表示言語を設定します。 "JPN" : 日本語表示 "ENG" : 英語表示</p> <p>以下に示す表示言語が変更されます。 (1) ティーチングボックスの表示 LCD (2) パソコンサポートソフトウェア ・ ロボットのアラームメッセージ ・ パラメータ説明リスト (3) 外部通信でロボットから読み出したアラームメッセージ (標準 RS232C、増設シリアルインタフェース、イーサネットインタフェース)</p>	1

5 Instruction Manual

5.1 The details of each instruction manuals

The contents and purposes of the documents enclosed with this product are shown below. Use these documents according to the application.

Instruction manuals enclosed in dashed lines in the list below are for optional products.

For special specifications, a separate instruction manual describing the special section may be enclosed.

Safety Manual	Explains the common precautions and safety measures to be taken for robot handling, system design and manufacture to ensure safety of the operators involved with the robot.
Standard Specifications	Explains the product's standard specifications, factory-set special specifications, option configuration and maintenance parts, etc. Precautions for safety and technology, when incorporating the robot, are also explained.
Robot Arm Setup & Maintenance	Explains the procedures required to operate the robot arm (unpacking, transportation, installation, confirmation of operation), and the maintenance and inspection procedures.
Controller Setup, Basic Operation and Maintenance	Explains the procedures required to operate the controller (unpacking, transportation, installation, confirmation of operation), basic operation from creating the program to automatic operation, and the maintenance and inspection procedures.
Detailed Explanation of Functions and Operations	Explains details on the functions and operations such as each function and operation, commands used in the program, connection with the external input/output device, and parameters, etc.
Troubleshooting	Explains the causes and remedies to be taken when an error occurs. Explanations are given for each error No.
Explanations of MOVEMASTER COMMANDS 	Explains details on the MOVEMASTER commands used in the program. (For RV-1A/2AJ, RV-2A/3AJ and RV-3S/3SJ/3SB/3SJB series)

Extended serial interface	Explains the specifications, functions and operations of the expansion serial interface optional.
CC-Link interface	Explains the specifications, functions and operations of the CC-Link interface optional.
ETHERNET interface	Explains the specifications, functions and operations of the ETHERNET interface optional.
Additional axis interface	Explains the specifications, functions and operations of the additional axis interface optional.
PROFIBUS interface	Explains the specifications, functions and operations of the PROFIBUS interface optional.
Personal computer Support software	Explains the specifications, functions and operations of the Personal computer Support software optional.

6 Safety

6.1 Safety

Measures to be taken regarding safety of the industrial robot are specified in the “Labor Safety and Sanitation Rules”. Always follow these rules when using the robot to ensure safety.

6.1.1 Self-diagnosis stop functions

This robot has the self-diagnosis stop functions shown in Table 6-1 and the stop functions shown in Table 6-2 for safe use.

Table 6-1 : Self-diagnosis stop functions

No.	Function		Details	Remarks
1	Overload protection function		Activates when the total servo current time exceeds the specified value.	The drive circuit is shut off. The robot stops, and an alarm displays.
2	Overcurrent diagnosis function		Activates when an overcurrent flows to the motor circuit.	The drive circuit is shut off. The robot stops, and an alarm displays.
3	Encoder disconnection diagnosis function		Activates when the encoder cable is disconnected.	The drive circuit is shut off. The robot stops, and an alarm displays.
4	Deflection over diagnosis function		Activates when an error occurs between the command value and actual position, and the error exceeds the specified amount.	The drive circuit is shut off. The robot stops, and an alarm displays.
5	AC power voltage drop diagnosis function		Activates when the AC power voltage drops below the specified value.	The drive circuit is shut off. The robot stops, and an alarm displays.
6	CPU error detection function		Activates when an error occurs in the CPU.	The drive circuit is shut off. The robot stops, and an alarm displays.
7	Overrun prevention function	Software limit detection	This is the limit provided by the software to enable operation only in the operation range.	The drive circuit is shut off. The robot stops, and an alarm displays.
		Mechanical stopper	This is the mechanical stopper provided outside the software.	

Table 6-2 : List of stop functions

Stop function	Operation panel	Teaching pendant	External input	Details
Emergency stop	○	○	○	This is the stop with the highest degree of emergency. The servo power is shut off, and the mechanical brakes (all axes) activate to stop the robot. To recover, reset the alarm, and turn the servo ON with the servo ON command.
Stop	○	○	○	This is a stop operation with a high degree of emergency. The robot immediately decelerates and stops. Note that the servo power is not shut off. Use this when using the collision evasion sensor, etc.

6.1.2 External input/output signals that can be used for safety protection measures

Table 6-3 : External input/output signals that can be used for safety protection measures

	Signal	Command	Functions	Usage method
Input	External emergency stop	(Input signal)	This servo power is shut off, and the robot stops immediately.	Externally installed emergency stop switch. Door switch on safety protection fence. Stopping at high-level error occurrence.
	Stop	STOP	The program execution is stopped, and the robot stops. The servo power is not shut off.	The robot is stopped when a peripheral device fault occurs. The servo power is not shut off.
	Servo OFF	SRVOFF	The servo power can be shut off.	The robot is stopped when a peripheral device fault occurs. The servo power is not shut off.
	Automatic operation enable	AUTOENA	Disables automatic operation when inactive.	Door switch on safety protection fence
Output	In servo ON	SRVON	The servo power ON/OFF state is output.	The servo power ON/OFF state is shown and alerted with the display lamps.
	Waiting	STOP	Outputs that the robot is temporarily stopped.	The temporary stop state is shown and alerted with the display lamps.
	In alarm	ERRRESET	Outputs when an alarm occurs in the robot.	The alarm state is shown and alerted with the display lamps.

[Caution] The external emergency stop input is prepared as a b contact for safety proposes. Thus, if the emergency stop input circuit is opened when the robot is started up, the robot will not operate. Refer to “Fig. 6-1 Example of safety measures” for details.

6.1.3 Precautions for using robot

The safety measures for using the robot are specified in the "Labor Safety and Sanitation Rules". An outline of the rules is given below.

(1) Robot installation

- Secure sufficient work space required to safely perform work such as teaching and maintenance related to the robot.
- Install the controller outside the robot's motion space. (If a safety fence is provided, install outside the fence.)
- Install the controller where the entire robot operation can be viewed.
- Install display lamps, etc., to indicate the robot's operation state.
- Securely fix the robot arm onto the fixing table with the designated bolts.

(2) Prevention of contact with operator

- Install a safety fence or enclosure so that the operator cannot easily enter the robot's motion space.
- Install an interlock function that will stop the robot if the safety fence or enclosure door is opened.

(3) Work procedures

- Create and observe work procedures for the robot teaching, operation, inspection and emergencies.
- Create hand signals to be followed when several operators are working together.
- Create displays such as "Teaching in Progress" and "Inspection in Progress" to be put up when an operator is in the robot's motion space so that other operators will not operate the operation panel (controller, control panel).

(4) Training

- Train the operators about the operations, maintenance and safety required for the robot work.
- Only trained and registered operators must operate the robot.
Participation in the "Special training for industrial robots" sponsored by the Labor Safety and Sanitation Committee, etc., is recommended for safety training.

(5) Daily inspection and periodic inspection

- Always inspect the robot before starting daily operations and confirm that there are no abnormalities.
- Set the periodic inspection standards in view of the robot's ambient environment and operation frequency, and perform periodic inspections.
- Make records when periodic inspections and repairs have been done, and store the records for three or more years.

6.1.4 Safety measures for automatic operation

- (1) Install safety fences so that operators will not enter the operation area during operation and indicate that automatic operation is in progress with lamps, etc.
- (2) Create signals to be given when starting operation, assign a person to give the signal, and make sure that the operator follows the signals.

6.1.5 Safety measures for teaching

Observe the following measures when teaching, etc., in the robot's operation range.

- (1) Specify and follow items such as procedures related to teaching work, etc.
- (2) Take measures so that operation can be stopped immediately in case of trouble, and measures so that operation can be restarted.
- (3) Take measures with the robot start switch, etc., to indicate that teaching work is being done.
- (4) Always inspect that stop functions such as the emergency stop device before starting the work.
- (5) Immediately stop the work when trouble occurs, and correct the trouble.
- (6) Take measures so that the work supervisor can immediately stop the robot operation when trouble occurs.
- (7) The teaching operator must have completed special training regarding safety. (Training regarding industrial robots and work methods, etc.)
- (8) Create signals to be used when several operators are working together.

6.1.6 Safety measures for maintenance and inspections, etc.

Turn the power OFF and take measures to prevent operators other than the relevant operator from pressing the start switch when performing inspections, repairs, adjustments, cleaning or oiling.

If operation is required, take measures to prevent hazards caused by unintentional or mistaken operations.

- (1) Specify and follow items such as procedures related to maintenance work, etc.
- (2) Take measures so that operation can be stopped immediately in case of trouble, and measures so that operation can be restarted.
- (3) Take measures with the robot start switch, etc., to indicate that work is being done.
- (4) Take measures so that the work supervisor can immediately stop the robot operation when trouble occurs.
- (5) The operator must have completed special training regarding safety. (Training regarding industrial robots and work methods, etc.)
- (6) Create signals to be used when several operators are working together.

6.1.7 Examples of safety measures

Emergency stop input circuits are prepared on the user wiring terminal block of the controller. Create a circuit as shown below for safety measures

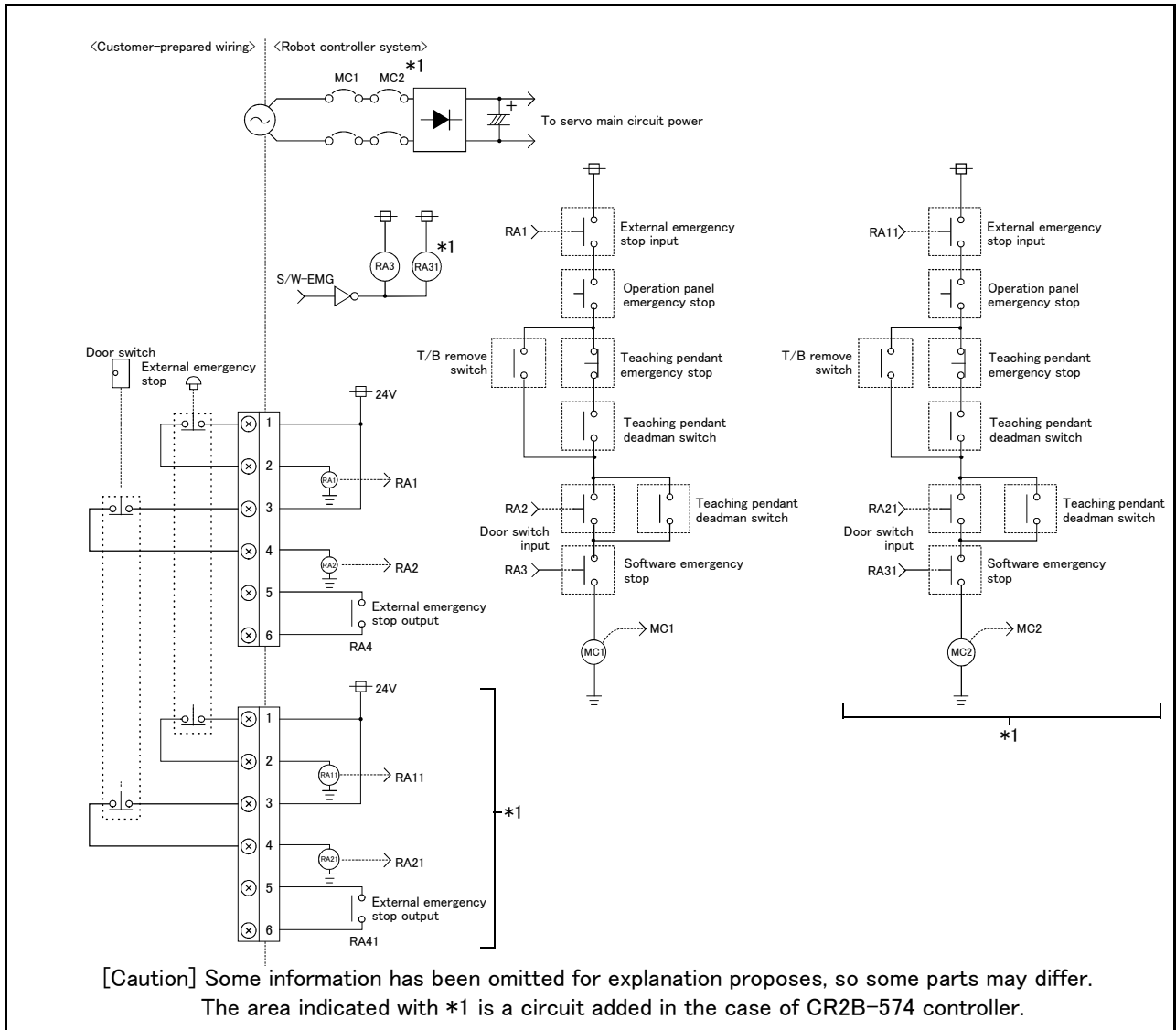

Fig.6-1 : Example of safety measures

- (1) In the case of CR2B-574 controller, use the 2-contact type for all the switches.
- (2) Install a limit switch on the safety fence's door. With a constantly open contact (a contact), wire to the door switch input terminal so that the switch turns ON (is conducted) when the door is closed, and turns OFF (is opened) when the door is open.
- (3) Use a manual-return type b-contact (a 2b-contact in the case of CR2B-574 controller) for the emergency stop button.
- (4) Classify the faults into minor faults (faults that are easily restored and that do not have a great effect) and major faults (faults that cause the entire system to stop immediately, and that require care in restoration), and wire accordingly.

[Caution] The emergency stop input(terminal block) on the user wiring in the controller can be used for safety measures as shown in Fig. 6-1. Note that there are limits to the No. of switch contacts, capacity and cable length, so refer to the following and install.

- Switch contact.....In the case of CR2B-574 controller, prepare a 2-contact type.
- Switch contact capacity.....Use a contact that operates with a switch contact capacity of approx. 1mA to 100mA/24V.
- Cable length.....The length of the wire between the switch and terminal block must be max. 15m or less.
- Emergency stop output capacity.....Set it within 300 mA/24 VDC.
Connecting an external device outside of the above range will cause a controller failure.

[Reference] The specifications of the RA1 and RA2 coil shown in Fig. 6-1 are as follow.

- Rated voltage..... DC24V \pm 10%
- Rated excitation current..... 12.5mA \pm 10% (at25 deg.)

* Note that these specifications are subject to change without prior notice for modification purposes.

The emergency stop circuit in the robot is a duplex type to ensure safety(CR2B-574 controller only).

Thus, if a 1b contact type is used, faults such as fusing in the emergency stop circuit will not be detected, and could lead to fires.

If a 1b contact type is used and the emergency stop is input with only one side (across No. 1-2 or No. 5-6), the contact fusing alarm will occur, and resetting of the alarm will not be possible.

6.2 Working environment

Avoid installation in the following places as the equipment's life and operation will be affected by the ambient environment conditions. When using in the following conditions, the customer must pay special attention to the preventive measures.

(1) Power supply

- Where the voltage fluctuation will exceed the input voltage range.
- Where a momentary power failure exceeding 20ms may occur.
- Where the power capacity cannot be sufficiently secured.

CAUTION

Please use the controller with an input power supply voltage fluctuation rate of 10% or less. In the case of 200 VAC input, for example, if the controller is used with 180 VAC during the day and 220 VAC during the night, turn the servo off once and then on again. If this is not performed, an excessive regeneration error may occur.

(2) Noise

- Where a surge voltage exceeding 1000V, 1 μ s may be applied on the primary voltage. Near large inverters, high output frequency oscillator, large contactors and welding machines. Static noise may enter the lines when this product is used near radios or televisions. Keep the robot away from these items.

(3) Temperature and humidity

- Where the atmospheric temperature exceeds 40 degree , lower than 0 degree.
- Where the relative humidity exceeds 85%, lower than 45%, and where dew may condense.
- Where the robot will be subject to direct sunlight or near heat generating sources such as heaters.

(4) Vibration

- Where excessive vibration or impact may be applied. (Use in an environment of 34m/s² or less during transportation and 5m/s² or less during operation.)

(5) Installation environment

- Where strong electric fields or magnetic fields are generated.
- Where the installation surface is rough. (Avoid installing the robot on a bumpy or inclined floor.)

6.3 Precautions for handling

- (1) This robot has brakes on all axes. The precision of the robot may drop, looseness may occur and the reduction gears may be damaged if the robot is moved with force with the brakes applied.
- (2) Avoid moving the robot arm by hand. When unavoidable, gradually move the arm. If moved suddenly, the accuracy may drop due to an excessive backlash, or the backed up data may be destroyed.
- (3) Note that depending on the posture, even when within the movement range, the wrist section could interfere with the base section. Take care to prevent interference during jog. ^{Note1)}
- (4) The robot arm is configured of precision parts such as bearings. Grease is used for lubricating these parts. When cold starting at low temperatures or starting operation after long-term stoppage, the position accuracy may drop or servo alarms may occur. If these problems occur, perform a 5 to 10 minute running-in operation at a low speed (about a half of normal operating speed).
- (5) The robot arm and controller must be grounded with Class D grounding to secure the noise resistance and to prevent electric shocks.
- (6) The items described in these specifications are conditions for carrying out the periodic maintenance and inspections described in the instruction manual.
- (7) When using the robot arm on a mobile axis or elevating table, the machine cables enclosed as standard configuration may break due to the fixed installation specifications. In this case, use the machine cable extension (for flexed)" factory shipment special specifications or options.
- (8) If this robot interferes with the workpiece or peripheral devices during operation, the position may deviate, etc. Take care to prevent interference with the workpiece or peripheral devices during operation.
- (9) The hanging installation jig can be borrowed from the maker. Order to dealer when need.
- (10) Do not attach a tape or a label to the robot arm and the controller. If a tape or a label with strong adhesive power, such as a packaging tape, is attached to the coated surfaces of the robot arm and controller, the coated surface may be damaged when such tape or label is peeled off.
- (11) If the robot is operated with a heavy load and at a high speed, the surface of the robot arm gets very hot. It would not result in burns, however, it may cause secondary accidents if touched carelessly.
- (12) Do not shut down the input power supply to stop the robot. If the power supply is frequently shut down during a heavy load or high-speed operation, the speed reducer may be damaged, backlash may occur, and the program data may be destroyed.
- (13) During the robot's automatic operation, a break is applied to the robot arm when the input power supply is shut down by a power failure, for instance. When a break is applied, the arm may deviate from the operation path predetermined by automatic operation and, as a result, it may interfere with the mechanical stopper depending on the operation at shutdown. In such a case, take an appropriate measure in advance to prevent any dangerous situation from occurring due to the interference between the arm and peripheral devices. Example) Installing a UPS (uninterruptible power supply unit) to the primary power source in order to reduce interference.
- (14) Do not conduct withstand voltage tests. If conducted, they may cause failures.

Note1) Jog operation refers to operating the robot manually using the teaching pendant.

7 Appendix

Appendix 1 : Specifications discussion material

■ Customer information

Company name		Name	
Address		Telephone	

■ Purchased mode

Specification	Type ^{Note1)}	
Standard specification	<input type="checkbox"/> RV-3SB	<input type="checkbox"/> RV-3SJB
Clean specification	<input type="checkbox"/> RV-3SBC	<input type="checkbox"/> RV-3SJBC
Specification with the controller protection box ^{Note2)}	<input type="checkbox"/> RV-3SB-SM	<input type="checkbox"/> RV-3SJB-SM

Note1) Refer to Page 2, "1.2 Model type combination of robot" for details on the type.

Note2) The controller protection box (CR1B-MB) is attached as standard.

■ Shipping special specifications (Settings can be made only at time of shipment)

Item	Standard specifications	Special shipping specifications
Robot arm Machine cable	<input type="checkbox"/> 5m fixed type	<input type="checkbox"/> 2m fixed type: 1S-02UCBL-03
Controller Controller structure	<input type="checkbox"/> Floor type	<input type="checkbox"/> Specification with the controller protection box(CR1B-571 controller only)

■ Options (Installable after shipment)

Item	Type	Provision, and specifications when provided.
Robot arm	Stopper for changing the operating range of the J1 axis	1A-DH-03 J1 axis + side: <input type="checkbox"/> +120° <input type="checkbox"/> +90° <input type="checkbox"/> +60° <input type="checkbox"/> +30° J1 axis - side: <input type="checkbox"/> -120° <input type="checkbox"/> -90° <input type="checkbox"/> -60° <input type="checkbox"/> -30°
	Machine cable extension	1S- <input type="checkbox"/> <input type="checkbox"/> CBL-03 <input type="checkbox"/> Not provided <input type="checkbox"/> 5m fixed type <input type="checkbox"/> 10m fixed type <input type="checkbox"/> 15m fixed type
		1S- <input type="checkbox"/> <input type="checkbox"/> LCBL-03 <input type="checkbox"/> Not provided <input type="checkbox"/> 5m flexed type <input type="checkbox"/> 10m flexed type <input type="checkbox"/> 15m flexed type
	Solenoid valve set	1S-VD0 <input type="checkbox"/> -02/ 1S-VD0 <input type="checkbox"/> E-02 <input type="checkbox"/> 1 set <input type="checkbox"/> 2 set <input type="checkbox"/> 3 set <input type="checkbox"/> 4 set
	Hand input cable	1S-HC25C-01 <input type="checkbox"/> Not provided <input type="checkbox"/> Provided
	Hand output cable	1S-GR35S-01 <input type="checkbox"/> Not provided <input type="checkbox"/> Provided
Hand curl tube	1E-ST040 <input type="checkbox"/> C <input type="checkbox"/> Not provided <input type="checkbox"/> 1 set <input type="checkbox"/> 2 set <input type="checkbox"/> 3 set <input type="checkbox"/> 4 set	
Controller	Teaching pendant	R28TB- <input type="checkbox"/> <input type="checkbox"/> <input type="checkbox"/> Not provided <input type="checkbox"/> 7m <input type="checkbox"/> 15m
	Pneumatic hand interface	2A-RZ365/2A-RZ375 <input type="checkbox"/> Not provided <input type="checkbox"/> Provided
	Parallel I/O interface ^{Note1)}	2A-RZ361/2A-RZ371 <input type="checkbox"/> Not provided <input type="checkbox"/> 1pc. <input type="checkbox"/> 2pcs. <input type="checkbox"/> 3pcs. <input type="checkbox"/> 4pcs. <input type="checkbox"/> 5pcs. <input type="checkbox"/> 6pcs. <input type="checkbox"/> 7pcs.
	External I/O cable	2A-CBL <input type="checkbox"/> <input type="checkbox"/> <input type="checkbox"/> Not provided <input type="checkbox"/> 5m-1pc. <input type="checkbox"/> 5m-2pcs. <input type="checkbox"/> 5m-3pcs. <input type="checkbox"/> 15m-1pcs. <input type="checkbox"/> 15m-2pcs. <input type="checkbox"/> 15m-3pcs.
	CC-Link interface	2A-HR575-E <input type="checkbox"/> Not provided <input type="checkbox"/> Provided
	Ethernet interface	2A-HR533-E <input type="checkbox"/> Not provided <input type="checkbox"/> Provided
	Extended serial interface	2A-RZ581-E <input type="checkbox"/> Not provided <input type="checkbox"/> Provided
	Additional axis interface	2A-RZ541-E <input type="checkbox"/> Not provided <input type="checkbox"/> Provided
	PROFIBUS interface	2A-RZ577-E <input type="checkbox"/> Not provided <input type="checkbox"/> Provided
	Personal computer cable	RS-MAXY-CBL/ RS-AT-RCBL <input type="checkbox"/> Not provided <input type="checkbox"/> RS-MAXY-CBL <input type="checkbox"/> RS-AT-RCBL
	Personal computer support software	3A-01C-WINE <input type="checkbox"/> Not provided <input type="checkbox"/> Windows95/98/2000/NT4.0/Me/XP CD-ROM
	Personal computer support software mini	3A-02C-WINE <input type="checkbox"/> Not provided <input type="checkbox"/> Windows95/98/2000/NT4.0/Me/XP CD-ROM
	Expansion option box ^{Note2)}	CR1-EB3 <input type="checkbox"/> Not provided <input type="checkbox"/> Provided
Controller protection box ^{Note2)}	CR1B-MB <input type="checkbox"/> Not provided <input type="checkbox"/> Specification with the controller protection box	

Note1) Up to eight units, including the one unit mounted as a standard.

Note2) This option only applies to the CR1B-571 controller.

■ Maintenance parts (Consumable parts)

Maintenance parts	<input type="checkbox"/> Backup batteries A6BAT () pcs. <input type="checkbox"/> Backup batteries ER6 () pcs. <input type="checkbox"/> Grease () cans
-------------------	--

■ Robot selection check list

Work description	<input type="checkbox"/> Material handling <input type="checkbox"/> Assembly <input type="checkbox"/> Machining L/UL <input type="checkbox"/> Sealing <input type="checkbox"/> Testing and inspection <input type="checkbox"/> Other ()		
Workpiece mass () g	Hand mass () g	Atmosphere	<input type="checkbox"/> General environment <input type="checkbox"/> Clean <input type="checkbox"/> Dust provided <input type="checkbox"/> Other()
Remarks			

Copy this page and use the copy.



Product Service

EC-Certificate of Conformity

No. E9 05 03 25554 001

Holder of Certificate: **Mitsubishi Electric Corporation**
Mitsubishi Denki Bldg., Marunouchi
Tokyo
100-8310 JAPAN

Name of Object: **Industrial Robot**

This EC-Certificate of Conformity is issued according to Article 10.2 of the Council Directive 89/336/EEC on the harmonization of the laws of the Member States relating to electromagnetic compatibility. It was transposed into the "Gesetz über die elektromagnetische Verträglichkeit von Geräten vom 18. September 1998 (EMVG, § 4 (2))". This Certificate does not contain any statement pertaining to the EMC protection requirements governed by other laws to implement EC Directives other than the aforementioned Council Directive 89/336/EEC. See also notes overleaf.

Test report no.: TYOEMC20016A

Date, 2005-03-23



TÜV Product Service GmbH is Competent Body in accordance with EMC Directive 89/336/EEC (BMPT VFG. 91/1992).

Page 1 of 3



EC-Certificate of Conformity
No. E9 05 03 25554 001

Model(s): RV-3S series
RV-3S, RV-3SJ
RV-3SC, RV-3SJC
RV-3SB, RV-3SJB
RV-3SBC, RV-3SJBC
RV-3S-S3xx, RV-3SJ-S3xx
RV-3SC-S3xx, RV3SJC-S3xx
RV-3SB-S3xx, RV-3SJB-S3xx
RV-3SBC-S3xx, RV-3SJBC-S3xx
for model differences see attachment

Description of Object: 230VAC, 1.0kVA/2.0kVA, 1 phase
Protection Class I



Product Service

Certificate Attachment 1

Certificate No./E9 05 01 25554 001

Pilot numbers and their specifications as follows

S3xx : driven by R/C CR2B-574

Sxx : driven by R/C CR1B-571

[none] : [none] means S00, driven by R/C CR1B-571

Number xx is specified in the table below.

Input/Output type	sink		source	
	Japanese	English	Japanese	English
Language				
Japan Domestic	00			
Shipping		11		12

DECLARATION OF CONFORMITY

We

(Company) : MITSUBISHI ELECTRIC CORPORATION
MITSUBISHI DENKI BLDG., Marunouchi, Tokyo 100-0081, Japan
(Factory) : NAGOYA WORKS
1-14, Yadaminami 5, Higashiku, Nagoya 461-8670, Japan

explain in own responsibility, that the products:

Kind of equipment : **INDUSTRIAL ROBOT**
Type-designation : **RV-3S series**
(See attached sheet to identify the type of model.)

are in compliance with following norms or documents:

1. Machinery Directive(98/37/EC)
 - (a) Type A : Fundamental safety standards
EN292-1/1991, EN292-2/1991, EN1050/1996
 - (b) Type B : Group safety standards
 - B1 : Safety aspects
EN60204-1/1997, EN294/1992, EN349/1993,
EN457/1992, EN999/1998, EN954-1:1996
 - B2 : Safety related devices
EN418 : 1992
 - (c) Type C : Machine safety standards
EN775 : 1992

2. EMC Directive(89/336/EEC),Amendment(92/31/EEC)
 - (a) EN55011:1998+ A2:2002, Group1, Class A
 - (b) EN61000-6-2:2001

Manager
Drive System Department in Nagoya Works

Nagoya, Japan / date:

Manufacture/Authorized representative

Eiichi Sugishima

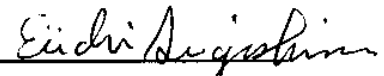

Place and date of issue name and signature

■ Declaration Type of models

a.6-axis vertical Robot Arm(3kg-load) basic model

Model Name	Robot Arm	Controller	Software Version
RV-3S	BU160C925G51	TU117C161	K or Later
	BU160C925G55	TU117C162/163	
RV-3SC	BU160C925G52	TU117C161	K or Later
	BU160C925G56	TU117C162/163	
RV-3SB	BU160C925G53	TU117C161	K or Later
	BU160C925G57	TU117C162/163	
RV-3SBC	BU160C925G54	TU117C161	K or Later
	BU160C925G58	TU117C162/163	

b.6-axis vertical Robot Arm(3kg-load) S300series

Model Name	Robot Arm	Controller	Software Version
RV-3S -S3xx	BU160C925G51	TU117C261	K or Later
	BU160C925G55	TU117C262/263	
RV-3SC -S3xx	BU160C925G52	TU117C261	K or Later
	BU160C925G56	TU117C262/263	
RV-3SB -S3xx	BU160C925G53	TU117C261	K or Later
	BU160C925G57	TU117C262/263	
RV-3SBC -S3xx	BU160C925G54	TU117C261	K or Later
	BU160C925G58	TU117C262/263	

c.5-axis vertical Robot Arm(3kg-load) basic model

Model Name	Robot Arm	Controller	Software Version
RV-3SJ	BU160C938G51	TU117C161	K or Later
	BU160C938G55	TU117C162/163	
RV-3SJC	BU160C938G52	TU117C161	K or Later
	BU160C938G56	TU117C162/163	
RV-3SJB	BU160C938G53	TU117C161	K or Later
	BU160C938G57	TU117C162/163	
RV-3SJBC	BU160C938G54	TU117C161	K or Later
	BU160C938G58	TU117C162/163	

d.5-axis vertical Robot Arm(3kg-load) S300series

Model Name	Robot Arm	Controller	Software Version
RV-3SJ -S3xx	BU160C938G51	TU117C261	K or Later
	BU160C938G55	TU117C262/263	
RV-3SJC -S3xx	BU160C938G52	TU117C261	K or Later
	BU160C938G56	TU117C262/263	
RV-3SJB -S3xx	BU160C938G53	TU117C261	K or Later
	BU160C938G57	TU117C262/263	
RV-3SJBC-S3xx	BU160C938G54	TU117C261	K or Later
	BU160C938G58	TU117C262/263	



HEAD OFFICE : MITSUBISHI DENKI BLDG MARUNOUCHI TOKYO 100-8310 TELEX : J24532 CABLE MELCO TOKYO
NAGOYA WORKS : 1-14, YADA-MINAMI 5, HIGASHI-KU, NAGOYA, JAPAN