



# INVERTER

## FR-F700

# PLC FUNCTION

# PROGRAMMING MANUAL

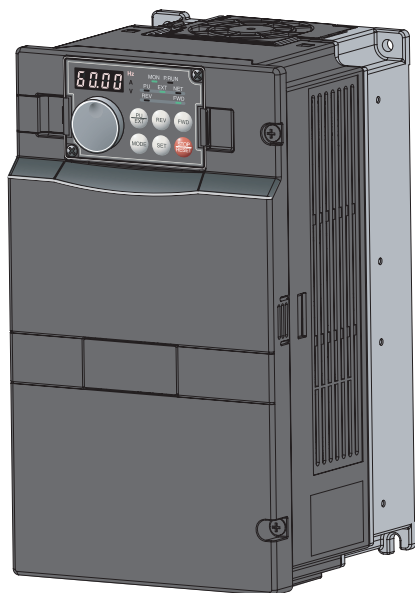

PLC FUNCTION **Chapter 1**

CC-Link  
COMMUNICATION **Chapter 2**

SEQUENCE  
PROGRAMMING **Chapter 3**

ERROR CODE  
LIST **Chapter 4**

# CONTENTS

<b>1. PLC FUNCTION</b>	<b>1</b>
<b>1.1 Compatible inverter models</b>	<b>2</b>
<b>1.2 Block diagram</b>	<b>2</b>
<b>1.3 Operation panel indication</b>	<b>3</b>
<b>1.4 PLC function specifications</b>	<b>4</b>
<b>1.5 System configuration</b>	<b>5</b>
<b>1.6 Wiring of the inverter and personal computer using GX Developer for RS-485 communication</b>	<b>6</b>
<b>1.7 Operation by PLC function (Pr. 414, Pr. 415, Pr. 498, Pr. 506 to Pr. 515, Pr. 826 to Pr. 865)</b>	<b>7</b>
<b>1.8 Prior to sequence program creation</b>	<b>8</b>
1.8.1 Precautions for sequence program creation	8
1.8.2 Usable main GX Developer functions	8
1.8.3 Sequence program execution key	9
1.8.4 Communication parameter setting	10
1.8.5 Sequence program write	11
1.8.6 Setting list of built-in PLC function parameter	12
<b>1.9 Device map</b>	<b>13</b>
1.9.1 I/O device map	13
1.9.2 Internal relay (M) device map	15
1.9.3 Data register (D) device map	15
1.9.4 Special relays	15
1.9.5 Special registers	17
<b>1.10 Inverter status monitoring, special registers for control</b>	<b>23</b>
1.10.1 Data that can be read at all times	23
1.10.2 Data that are read by controlling (OFF to ON) the read command	27
1.10.3 How to write data by controlling (OFF to ON) the write command	29
1.10.4 Inverter operation status control	35
1.10.5 Inverter parameter access error (D9150)	37
1.10.6 Inverter status (D9151)	37
1.10.7 User defined fault (D9214)	38
1.10.8 Monitor setting selection(D9215 to D9218)	39
<b>1.11 Inverter parameter read/write method</b>	<b>40</b>
1.11.1 Reading the inverter parameters	40
1.11.2 Writing the inverter parameters	42
<b>1.12 User area read/write method</b>	<b>44</b>
1.12.1 User parameter read/write method	44

1.12.2	User parameter EEPROM read/write method.....	45
<b>1.13</b>	<b>Analog I/O function .....</b>	<b>46</b>
1.13.1	Analog input.....	46
1.13.2	Analog output.....	46
<b>1.14</b>	<b>PID control .....</b>	<b>47</b>
<b>1.15</b>	<b>Inverter operation lock mode setting .....</b>	<b>49</b>
<b>1.16</b>	<b>Clearing of Flash Memory for PLC Function .....</b>	<b>50</b>
<b>2.</b>	<b>CC-Link COMMUNICATION .....</b>	<b>51</b>
<hr/>		
<b>2.1</b>	<b>System configuration .....</b>	<b>52</b>
2.1.1	System configuration example.....	52
2.1.2	Function block diagram.....	53
<b>2.2</b>	<b>CC-Link parameters .....</b>	<b>55</b>
2.2.1	CC-Link extended setting (Pr. 544).....	55
<b>2.3</b>	<b>CC-Link I/O specifications.....</b>	<b>56</b>
2.3.1	I/O signal when CC-Link Ver.1 one station is occupied (Pr. 544 = 100).....	56
2.3.2	I/O signal when CC-Link Ver.2 double setting is selected (Pr. 544 = 112) .	58
2.3.3	I/O signal when CC-Link Ver.2 quadruple setting is selected (Pr. 544 = 114).....	60
2.3.4	I/O signal when CC-Link Ver.2 octuple setting is selected (Pr. 544 = 118)	61
<b>2.4</b>	<b>Buffer memory .....</b>	<b>63</b>
2.4.1	Remote output signals (Master module to inverter(FR-A7NC)).....	63
2.4.2	Remote input signals Pr.544=100 (Inverter(FR-A7NC) to master module).....	64
2.4.3	Remote registers Pr.544=100 (Master module to inverter(FR-A7NC)).....	65
2.4.4	Remote registers Pr.544=100 (Inverter(FR-A7NC) to master module).....	66
<b>3.</b>	<b>SEQUENCE PROGRAMMING .....</b>	<b>67</b>
<hr/>		
<b>3.1</b>	<b>Overview .....</b>	<b>68</b>
3.1.1	Outline of operation processings .....	68
<b>3.2</b>	<b>RUN and STOP operation processings.....</b>	<b>70</b>
<b>3.3</b>	<b>Program makeup.....</b>	<b>70</b>
<b>3.4</b>	<b>Programming languages.....</b>	<b>71</b>
3.4.1	Relay symbolic language (ladder mode).....	71
3.4.2	Logic symbolic language (list mode).....	73
<b>3.5</b>	<b>Operation processing method of PLC function .....</b>	<b>74</b>

<b>3.6</b>	<b>I/O processing method .....</b>	<b>75</b>
3.6.1	What is refresh system?.....	75
3.6.2	Response delay in refresh system .....	76
<b>3.7</b>	<b>Scan time .....</b>	<b>77</b>
<b>3.8</b>	<b>Numerical values usable in sequence program .....</b>	<b>78</b>
3.8.1	BIN (Binary Code).....	79
3.8.2	HEX (HEX Decimal) .....	81
<b>3.9</b>	<b>Description of devices .....</b>	<b>82</b>
3.9.1	Device list.....	82
3.9.2	Inputs, outputs X, Y .....	83
3.9.3	Internal relays M.....	86
3.9.4	Timers T .....	87
3.9.5	100ms, 10ms and 100ms retentive timers .....	87
3.9.6	Timer processing method and accuracy .....	88
<b>3.10</b>	<b>Counters C .....</b>	<b>90</b>
3.10.1	Count processing in refresh system .....	91
3.10.2	Maximum counting speed of counter .....	92
<b>3.11</b>	<b>Data registers D .....</b>	<b>93</b>
<b>3.12</b>	<b>Special relays, special registers .....</b>	<b>94</b>
<b>3.13</b>	<b>Function list .....</b>	<b>96</b>
<b>3.14</b>	<b>How to RUN/STOP the built-in PLC function from outside (re- mote RUN/STOP) .....</b>	<b>97</b>
<b>3.15</b>	<b>Watchdog timer (operation clog up monitor timer).....</b>	<b>99</b>
<b>3.16</b>	<b>Self-diagnostic function .....</b>	<b>100</b>
3.16.1	Error-time operation mode .....	101
<b>3.17</b>	<b>Keyword registration .....</b>	<b>102</b>
<b>3.18</b>	<b>Setting of output (Y) status at switching from STOP status to RUN status .....</b>	<b>103</b>
<b>3.19</b>	<b>Instruction format.....</b>	<b>104</b>
<b>3.20</b>	<b>Bit device processing method .....</b>	<b>106</b>
3.20.1	1-bit processing .....	106
3.20.2	Digit designation processing .....	106
<b>3.21</b>	<b>Handling of numerical value .....</b>	<b>110</b>
<b>3.22</b>	<b>Operation error .....</b>	<b>111</b>
<b>3.23</b>	<b>Instructions list.....</b>	<b>112</b>
3.23.1	How to use the instruction list.....	112
3.23.2	Sequence instruction.....	114
3.23.3	Basic instructions .....	116
3.23.4	Application instructions.....	120

<b>3.24 Description of the instructions .....</b>	<b>121</b>
<b>3.25 Sequence instructions.....</b>	<b>122</b>
3.25.1 Contact Instructions :	
Operation start, series connection, parallel connection	
... LD, LDI, AND, ANI, OR, ORI .....	122
3.25.2 Connection instructions :	
ladder block series connection, parallel connection ... ANB, ORB .....	125
3.25.3 Connection instructions :	
operation result, push, read, pop ... MPS, MRD, MPP .....	128
3.25.4 Output instructions : bit device, timer, counter ... OUT .....	131
3.25.5 Output Instructions : Device set, reset ... SET, RST .....	134
3.25.6 Output instructions : leading edge, trailing edge differential outputs	
... PLS, PLF.....	137
3.25.7 Shift Instructions : Bit device shift ... SFT, SFTP .....	139
3.25.8 Master control instructions : master control set, reset ... MC, MCR.....	141
3.25.9 End Instruction : Sequence program end ... END.....	145
3.25.10 Other Instructions : No operation ... NOP .....	146
<b>3.26 Basic instructions (16-bit).....</b>	<b>148</b>
3.26.1 Comparison Operation Instructions .....	148
3.26.2 Comparison Operation Instructions :	
16-bit data comparison ... =, <>, >, <=, <, >=.....	150
3.26.3 Arithmetic Operation Instructions .....	152
3.26.4 Arithmetic Operation Instructions :	
BIN 16-bit addition, subtraction ... +, +P, -, -P .....	153
3.26.5 Arithmetic operation instructions :	
BIN 16-bit multiplication, division ... *, *P, /, /P.....	157
3.26.6 Data transfer instructions .....	161
3.26.7 Data transfer instructions :	
16-bit data transfer ... MOV, MOVP .....	161
<b>3.27 Basic instructions (32-bit).....</b>	<b>163</b>
3.27.1 Comparison Operation Instructions .....	163
3.27.2 Comparison Operation Instructions :	
32-bit data comparison ... D=, D<>, D>, D<=, D<, D>= .....	165
3.27.3 Arithmetic Operation Instructions.....	167
3.27.4 Arithmetic Operation Instructions :	
BIN 32-bit addition, subtraction ... D+, D+P, D-, D-P .....	168
3.27.5 Arithmetic operation instructions :	
BIN 32-bit multiplication, division ... D*, D*P, D/, D/P .....	172
3.27.6 Data transfer instructions .....	176
3.27.7 Data transfer instructions :	
32-bit data transfer ... DMOV, DMOV .....	176
<b>3.28 Application instructions.....</b>	<b>178</b>
3.28.1 Logical operation instructions .....	178

- 3.28.2 Logical operation instructions :  
16-bit logical product ... WAND, WANDP ..... 179
- 3.28.3 Logical operation instructions :  
16-bit logical add ... WOR, WORP ..... 182
- 3.28.4 Logical operation instructions :  
16-bit exclusive logical add ... WXOR, WXORP ..... 185
- 3.28.5 Logical operation instructions :  
16-bit not exclusive logical add ... WXNR, WXNRP ..... 188
- 3.28.6 Logical operation instructions :  
BIN 16-bit 2's complement ... NEG, NEGP ..... 191
- 3.29 Display command.....193**
- 3.29.1 PU display function command ... PR..... 193
- 3.29.2 ASCII code conversion command ... ASC..... 198

---



---

**4. ERROR CODE LIST 201**

**4.1 How to read the error code.....202**

---



---

**APPENDIX 205**

**Appendix 1 Instruction processing time.....206**

# MEMO

# 1. PLC FUNCTION

This manual describes the functions and devices necessary for programming.

<b>1.1</b>	<b>Compatible inverter models .....</b>	<b>2</b>
<b>1.2</b>	<b>Block diagram.....</b>	<b>2</b>
<b>1.3</b>	<b>Operation panel indication .....</b>	<b>3</b>
<b>1.4</b>	<b>PLC function specifications .....</b>	<b>4</b>
<b>1.5</b>	<b>System configuration.....</b>	<b>5</b>
<b>1.6</b>	<b>Wiring of the inverter and personal computer using GX Developer for RS-485 communication....</b>	<b>6</b>
<b>1.7</b>	<b>Operation by PLC function (Pr. 414, Pr. 415, Pr. 498, Pr. 506 to Pr. 515, Pr. 826 to Pr. 865) .....</b>	<b>7</b>
<b>1.8</b>	<b>Prior to sequence program creation .....</b>	<b>8</b>
<b>1.9</b>	<b>Device map .....</b>	<b>13</b>
<b>1.10</b>	<b>Inverter status monitoring, special registers for control .....</b>	<b>23</b>
<b>1.11</b>	<b>Inverter parameter read/write method .....</b>	<b>40</b>
<b>1.12</b>	<b>User area read/write method .....</b>	<b>44</b>
<b>1.13</b>	<b>Analog I/O function .....</b>	<b>46</b>
<b>1.14</b>	<b>PID control .....</b>	<b>47</b>
<b>1.15</b>	<b>Inverter operation lock mode setting .....</b>	<b>49</b>

**Chapter 1**

**Chapter 2**

**Chapter 3**

**Chapter 4**





## 1.1 Compatible inverter models

This Instruction Manual provides information about the PLC function, which is available with the upgraded FR-F700-NA/EC inverters. To find out whether an FR-F700-NA/EC is equipped with the PLC function, check the Instruction Manual of the inverter.

## 1.2 Block diagram

How I/O data is transferred to/from the inverter by the built-in PLC function is explained using function blocks.

- (1) I/O data read, write, etc. can be performed by accessing the inverter in the predetermined method using special relays, special registers, etc.
- (2) Operation, parameter read/write, etc. can be performed in accordance with the created sequence programs (built in the inverter) using input data from the control input terminals.

With the output signals, output data can be output to outside the inverter from the control output terminals as not only the inverter's status signals but also pilot lamp on/off, interlock and other control signals set freely by the user.

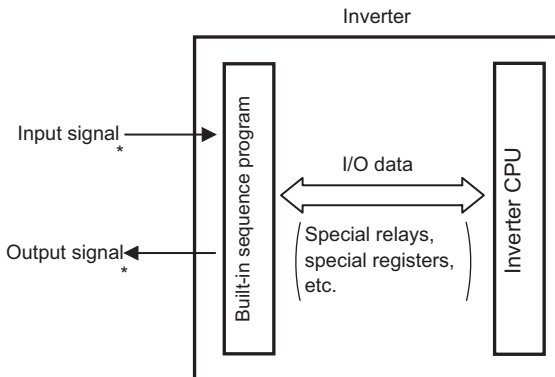

\* Setting "9999" in *Pr.178 to Pr.189 (input terminal function assignment)* and *Pr.190 to Pr.196 (output terminal function selection)* changes these terminals to general-purpose I/O terminals. Refer to the inverter manual for details of *Pr. 178 to Pr.189* and *Pr.190 to Pr.196*.



### 1.3 Operation panel indication

When a PLC program is in execution, P.RUN LED on the operation panel (FR-DU07) or P.RUN display on the parameter unit (FR-PU07(-01)) are as shown below table.

FR-DU07

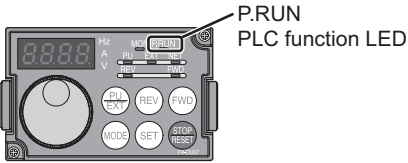

FR-PU07(-01)

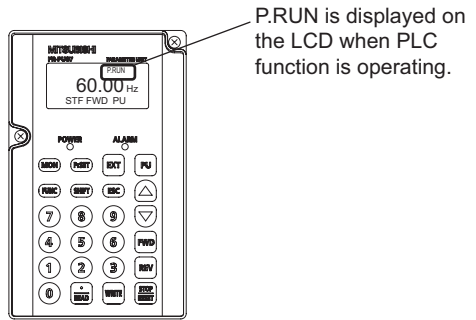

#### P.RUN status

LED (LCD) operation	Status
Off (normal display)	Sequence program is at a stop
On (inverted display)	Sequence program is in progress
Blinking (flickering)	Sequence error is occurring



## 1.4 PLC function specifications

The following table indicates the program capacity and devices of the PLC function.

		F700 Sequence Section	
Control method		Repeated operation (by stored program)	
I/O control method		Refresh	
Programming language		Relay symbolic language (ladder mode) Logic symbolic language (list mode)	
Number of instruction	PLC instructions	23	
	Basic instructions	64	
	Application instructions	20	
Processing speed		PLC instruction: 1.9 $\mu$ s to 12 $\mu$ s/step(*1)	
Number of I/O points		128 (X: 64 points, Y: 64 points) 19 points installed, X: 12 points, Y: 7 points(*2) FR-A7AX, X: 16 points FR-A7AY, Y: 6 points FR-A7AR, Y: 3 points	
Number of analog I/O points		5 points installed, Input: 3 points, Output: 2 points FR-A7AY output: 2 points	
Watchdog timer		10 to 2000(ms)	
Memory capacity		6k bytes used by sequence and parameters.	
Program capacity		4k step (Can be edited from 0 to 4094 steps.)	
Devices	Internal relay (M)	64(M0 to M63)	
	Latch relay (L)	None (Can be set with parameters but will not latch) (*3)	
	Step relay (S)	None (Can be set with parameters but will operate as M)	
	Link relay (B)	None	
	Timer (T)	Points	16
		Specifications	100ms timer: Set time 0.1 to 3276.7s (T0 to T15) 10ms timer: Set time 0.01 to 327.67s 100ms retentive timer: Set time 0.1 to 3276.7s
	Counter (C)	Points	16
		Specifications	Normal counter: Setting range 1 to 32767 (C0 to C15) Interrupt program counter: None
	Data device (D)	160(D0 to D159)	
	Link register (W)	None	
	Annunciator (F)	None	
	File register (R)	None	
	Accumulator (A)	None	
	Index register (Z, V)	None	
	Pointer (P)	None	
	Interrupt pointer (I)	None	
Special relay (M)	256 (M9000 to 9255) with function limit		
Special register (D)	256 (D9000 to 9255) with function limit		

\*1 As inverter control is also performed actually, the scan time is approximately 40ms at 500 steps.

\*2 These signals use the same terminals as used by the input and output signals given in the common specifications of the inverter.

One point is always necessary for a sequence start (RUN/STOP).

\*3 Function to latch a device at power failure is not provided.

Therefore, select EEPROM for storage using *Pr.506 to Pr.515, Pr.826 to Pr.865* User parameter (D110 to D159) to hold device values. (Refer to page 44.)

### REMARKS

- No buffer memory is available.

## 1.5 System configuration

The following shows the system configuration for use of the PLC function.

### <System configuration example>

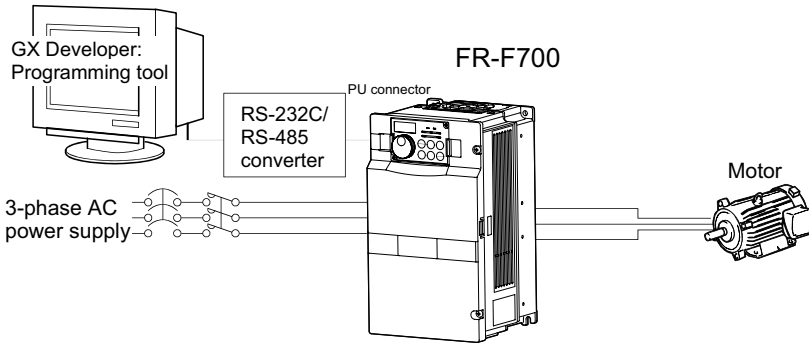

#### POINT

- Support GX Developer ver.8.0 or more
- GX Developer Setting

PLC series	<b>ACPU</b>
PLC type	<b>A0J2H</b>

[Project data list]→[Parameter]→[PLC parameter]→[A parameter] →«Memory capacity» tab→"Program capacity"→"Sequence"→"main"	<b>4k step</b>
--	----------------

#### REMARKS

- Refer to the *Inverter Instruction Manual* for wiring.
- Refer to the GX Developer manuals for the specifications related to GX Developer and the personal computer that uses GX Developer.  
GX Developer Version xx Operating manual  
GX Developer Version xx Operating manual (startup)
- The programming tool that can be used is GX Developer only. (The A6GPP, A7PHP, etc. cannot be used.)



## 1.6 Wiring of the inverter and personal computer using GX Developer for RS-485 communication

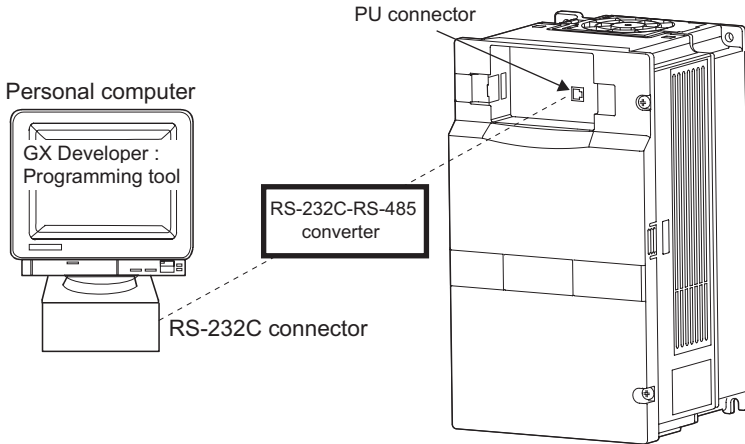

● Personal computer - inverter connection cable

Make connection after conversion between RS-232C and RS-485.

Examples of commercially available products (as of Sep., '05)

Type	Maker
SC-FRPC	BEIJERS

### REMARKS

When fabricating the cable on the user side, refer to the *Inverter Instruction Manual*.

## 1.7 Operation by PLC function (Pr. 414, Pr. 415, Pr. 498, Pr. 506 to Pr. 515, Pr. 826 to Pr. 865)

I/O data read, write, etc. can be performed by accessing the inverter in the predetermined method using special relays, special registers, etc.

Operation, parameter read/write, etc. can be performed in accordance with the created sequence programs (built in the inverter) using input data from the control input terminals.

With the output signals, output data can be output to outside the inverter from the control output terminals as not only the inverter's status signals but also pilot lamp on/off, interlock and other control signals set freely by the user.

Parameter Number	Name	Initial Value	Setting Range	Refer to Page
414	PLC function operation selection	0	0, 1	9
415	Inverter operation lock mode setting	0	0, 1	49
498	PLC function flash memory clear	0	0 to 9999	50
506 to 515	Parameter 1 to 10 for user	0	0 to 65535	15
826 to 865	Parameter 11 to 50 for user			



## 1.8 Prior to sequence program creation

---

### 1.8.1 Precautions for sequence program creation

#### POINT

- Online change of the sequence program and access to other stations are not allowed.  
In addition, program read/write from other stations and all PLC memory clear cannot be performed.
- Back up the ladder configured with the protective function of GX Developer.

If any of the instructions (*refer to page 112*) and devices (*refer to page 4*) that cannot be used with the built-in PLC function exists in a sequence program, an instruction code error occurs at the execution of that instruction.

Error code	D9008=10
Operation error step	D9010
	D9011

#### REMARKS

- Refer to page 26 for the error codes.

### 1.8.2 Usable main GX Developer functions

- Parameter or sequence program read/write
- Ladder monitor
- Device monitor
- Device test
- All device memory clear
- Remote RUN/STOP

#### CAUTION

---

Device test ([Online] - [Debug] - [Device test]) of GX Developer can be performed, but if devices corresponding to control terminal (e.g. STF, STR) signals are tested, the devices turn on in the sequence but the inverter does not perform the corresponding operation.

---



### 1.8.3 Sequence program execution key

Parameter Number	Name	Initial Value	Setting Range	Description
414	PLC function operation selection	0	0	PLC function is invalid
			1	PLC function is valid (Inverter reset is necessary to make this setting valid.)

The sequence program execution key (STOP/RUN) of the PLC is switched by turning off/on the SQ signal.

#### POINT

- Set "1" in *Pr.414 PLC function operation selection*.
- For the terminal used for SQ signal input, set "50" in any of *Pr.178 to Pr. 189* to assign the function.
- The SQ signal must be turned ON to execute the built-in PLC function.

#### CAUTION

If the SQ signal is not turned ON, the start signal of the inverter is designed to become valid by the factory setting of *Pr.415 Inverter operation lock mode setting*.

Turn the SQ signal OFF (STOP) before writing a sequence program, etc.

Turn the SQ signal ON (RUN) to execute a sequence program.

Remote run/stop of the built-in PLC function can be executed in any of the following methods:

- Setting using the built-in PLC function parameter (contact)
- Using GX Developer
- Via CC-Link communication (*refer to page 55*)

#### REMARKS

- The validity limit of the SQ signal can be controlled using *Pr.415 Inverter operation lock mode setting*. (*Refer to page 49.*)

#### CAUTION

The outputs (Y) are cleared by turning the SQ signal off (STOP) after sequence program execution (SQ signal ON).

The other devices retain the device data prior to STOP. When you want to clear the remaining device data, power off or reset (RES signal ON for 0.1s, then OFF) the inverter.





## 1.8.4 Communication parameter setting

### POINT

Communication with GX Developer can not be made if values of communication parameters (Pr.117 to Pr.124) of the inverter are initial settings.

Before writing sequence program from GX Developer, communication parameters need to be set to the GX Developer setting.

Set the parameters as shown below.

Inverter Parameter	Inverter Initial Setting	GX Developer Setting
<i>Pr.118 PU communication speed</i>	192 (19200bps)	96 (9600bps)
<i>Pr.119 PU communication stop bit length</i>	1 (data length: 8 bits, stop bit: 2-bit)	0 (data length: 8 bits, stop bit: 1-bit)
<i>Pr.120 PU communication parity check</i>	2 (with even parity check)	1 (with odd parity check)
<i>Pr.122 PU communication check time interval</i>	9999 (without communication check)	9999 (without communication check)

### REMARKS

- Use the operation panel (FR-DU07) or parameter unit (FR-PU04/FR-PU07(-01) option unit) to change the inverter parameter setting. Either one of an operation panel, a parameter unit or GX Developer (personal computer) can be connected to the PU connector.
- Refer to the inverter manual for details of each communication parameter.

### CAUTION

- Executing parameter clear/all clear clears the setting value of communication parameters, which disables communication with GX Developer.

## 1.8.5 Sequence program write

### POINT

Sequence program write can be performed in any operation mode (External operation mode/PU operation mode/Network operation mode). Refer to the inverter manual for operation mode.

When rewriting the PLC function parameters and sequence program using GX Developer, check the following:

- 1) Check that the sequence program execution key is in the STOP position (SQ signal is off) (*refer to page 9*).
- 2) Check that the inverter is at a stop.
- 3) Check that the communication specification setting parameters (*Pr.117 to Pr.124*) are set correctly. If any of these parameters is set incorrectly, communication with GX Developer cannot be made.
- 4) Check the PLC series and sequence program capacity in the GX Developer parameters (*refer to page 5*).
- 5) Refer to the GX Developer manual and write the sequence program.

### CAUTION

- A sequence program cannot be written with its steps specified. If written, the sequence program does not run. (The program outside the specified range is initialized.)
- Do not read the built-in PLC function parameters and sequence program without writing them to the inverter once using GX Developer. Since the inverter does not have normal data, always write the built-in PLC function parameters and sequence program once.
- Since the built-in PLC function parameters and sequence program are written to the flash ROM, there are restrictions on the number of write times. (Approximately 100,000 times)
- 4K step or more can not be written.  
Number of steps usable when a program capacity is 4K step are calculated as below.  
 $4 \times 1024 - 2 \text{ steps} = 4094 \text{ steps}$   
Therefore, the write area is 0 to 4094 steps.



## 1.8.6 Setting list of built-in PLC function parameter

The built-in PLC function parameters are designed to specify the ranges of using the PLC function, e.g. program capacity, device assignment and various functions.

Item	GX Developer Default	Setting Range <Usable device range>
Sequence program capacity	6k steps	4k step
File register capacity	None	Cannot be set (default)
Comment capacity	None	Cannot be set (default)
Status latch	None	Cannot be set (default)
Sampling trace	None	Cannot be set (default)
Microcomputer program capacity	None	Cannot be set (default)
Latch range setting	L1000 to L2047	Cannot be set (invalid if set)
Link range setting	None	Cannot be set (default)
I/O assignment	None	Cannot be set (default)
Internal relay, latch relay, step relay setting	M0 to 999 L1000 to 2047 None for S	L and S cannot be set. (Operates as M if set) <M0 to M63>
Watchdog timer setting	200ms	10 to 2000ms
Timer setting	100ms: T0 to 199 10ms: T200 to 255 (100ms timers since only T0 to 7 are available)	16 points for 100ms, 10ms and retentive timers. Timers have consecutive numbers. <T0 to T15>
Counter setting	Without interrupt counters	Cannot be set (default) <C0 to C15>
Remote run/pause	None	Can be set using X0 to X3F. Otherwise invalid. Pause does not function.
Error-time operation mode	Fuse blow: Continued	Setting invalid (since there are no fuses)
	I/O verify error: Stop	Setting invalid (since there are no I/O modules)
	Operation error: Continued	Stop/Continued
	Special function module check error: Stop	Setting invalid (since there are no special modules)
STOP → RUN output mode	Operation status prior to STOP is re-output.	Prior to STOP/after operation execution
Print title registration	None	Cannot be set
Keyword registration	None	Online setting cannot be made but parameter setting is valid.

### REMARKS

- The following functions are not supported.
  1. Constant scan, 2. Latch (device data backup for power failure), 3. Pause, 4. Status latch, 5. Sampling trace, 6. Offline switch
- If parameter clear of the inverter is performed, the above built-in PLC function parameters are not cleared.
- For the built-in PLC function parameter setting operation, refer to the GX Developer Operating Manual.



# 1.9 Device map

## 1.9.1 I/O device map

	Device No.	Name	Remarks	Device No.	Name	Remarks
External I/O	X00	STF terminal	External terminal	Y00	RUN terminal	External terminal
	X01	STR terminal		Y01	SU terminal	
	X02	RH terminal		Y02	OL terminal	
	X03	RM terminal		Y03	IPF terminal	
	X04	RL terminal		Y04	FU terminal	
	X05	JOG terminal		Y05	ABC1 terminal	
	X06	RT terminal		Y06	ABC2 terminal	
	X07	AU terminal		Y07	Empty (Can be used as temporary storage)	
	X08	CS terminal		Y08		
	X09	MRS terminal		Y09		
	X0A	STOP terminal		Y0A		
	X0B	RES terminal		Y0B		
	X0C	Empty (Can be used as temporary storage)		Y0C		
	X0D			Y0D		
X0E	Y0E					
X0F	Y0F					
Plug in option I/O	X10	X0 terminal	16-bit digital Input FR-A7AX	Y10	DO0 terminal	Digital output FR-A7AY
	X11	X1 terminal		Y11	DO1 terminal	
	X12	X2 terminal		Y12	DO2 terminal	
	X13	X3 terminal		Y13	DO3 terminal	
	X14	X4 terminal		Y14	DO4 terminal	
	X15	X5 terminal		Y15	DO5 terminal	
	X16	X6 terminal		Y16	DO6 terminal	Relay output FR-A7AR
	X17	X7 terminal		Y17	RA1 terminal	
	X18	X8 terminal		Y18	RA2 terminal	Empty (Can be used as temporary storage)
	X19	X9 terminal		Y19	RA3 terminal	
	X1A	X10 terminal		Y1A		
	X1B	X11 terminal		Y1B		
	X1C	X12 terminal		Y1C		
	X1D	X13 terminal		Y1D		
X1E	X14 terminal	Y1E				
X1F	X15 terminal	Y1F				

Device Map

1

PLC FUNCTION



	Device No.	Name	Remarks	Device No.	Name	Remarks
System I/O	X20	Operation mode setting read completion	D9140	Y20	Operation mode setting read command	D9140
	X21	Set frequency read completion (RAM)	D9141	Y21	Set frequency read command (RAM)	D9141
	X22	Set frequency read completion (EEPROM)	D9142	Y22	Set frequency read command (EEPROM)	D9142
	X23	Operation mode setting write completion	D9143	Y23	Operation mode setting write command	D9143
	X24	Set frequency write completion (RAM)	D9144	Y24	Set frequency write command (RAM)	D9144
	X25	Set frequency write completion (EEPROM)	D9145	Y25	Set frequency write command (EEPROM)	D9145
	X26	Faults history batch clear completion	D9146	Y26	Faults history batch clear command	D9146
	X27	Parameter clear completion	D9147	Y27	Parameter clear command	D9147
	X28	Parameter read completion (RAM)	D9241, D9242, D9234	Y28	Parameter read request (RAM)	D9241, D9242, D9234
	X29	Parameter write completion (RAM)		Y29	Parameter write request (RAM)	
	X2A	Parameter read completion (EEPROM)	D9243, D9244, D9235	Y2A	Parameter read request (EEPROM)	D9243, D9244, D9235
	X2B	Parameter write completion (EEPROM)		Y2B	Parameter write request (EEPROM)	
	X2C	User parameter read completion (RAM)	D110 to D159 (Pr.506 to Pr.515, Pr.826 to Pr.865)	Y2C	User parameter read (RAM)	D110 to D159 (Pr.506 to Pr.515, Pr.826 to Pr.865)
	X2D	User parameter write completion (RAM)		Y2D	User parameter write (RAM)	
X2E	User parameter read completion (EEPROM)	Y2E		User parameter read (EEPROM)		
X2F	User parameter write completion (EEPROM)	Y2F		User parameter write (EEPROM)		
CC-Link I/O remote I/O	X30	RY0	FR-A7NC	Y30	RX0	FR-A7NC
	X31	RY1		Y31	RX1	
	X32	RY2		Y32	RX2	
	X33	RY3		Y33	RX3	
	X34	RY4		Y34	RX4	
	X35	RY5		Y35	RX5	
	X36	RY6		Y36	RX6	
	X37	RY7		Y37	RX7	
	X38	RY8		Y38	RX8	
	X39	RY9		Y39	RX9	
	X3A	RYA		Y3A	RXA	
	X3B	RYB		Y3B	RXB	
	X3C	RYC		Y3C	RXC	
	X3D	RYD		Y3D	RXD	
X3E	RYE	Y3E	RXE			
X3F	RYF	Y3F	RXF			

---

**CAUTION**

---

**X2C, X2D, Y2C and Y2D are system area. Do not use.**

---



### 1.9.2 Internal relay (M) device map

Device No.	Description
M0 to M63	Use freely on user side.

### 1.9.3 Data register (D) device map

Data Register (D)	Inverter Pr. Number	Parameter Name	Reference Page
D0 to D109	Use freely on user side.		—
D110 to D159	<i>Pr.506 to Pr.515, Pr.826 to Pr.865</i>	User parameters. Use freely on user side.	44

### 1.9.4 Special relays

The special relays are internal relays with special applications and therefore should not be switched on-off in the program.

Number	Name	Description
M9008	Self-diagnostic error	Turned on by self-diagnosed error.
M9010	Operation error flag	Turned on by an instruction execution error. Turned off when error is removed.
M9011	Operation error flag	Turned on by an instruction execution error. Remains on after normal status is restored.
M9036	Normally ON	M9036 and M9037 are turned on and off independently of STOP or RUN.
M9037	Normally OFF	
M9038	On only for 1 scan after RUN	M9038 and M9039 change depending on the STOP or RUN status. In other than the STOP status, M9038 is on for one scan only and M9039 is off for one scan only.
M9039	Off only for 1 scan after RUN	
M9200	Inverter operation status control flag (STF)	Control the STF terminal of the inverter from PLC function
M9201	Inverter operation status control flag (STR)	Control the STR terminal of the inverter from PLC function
M9202	Inverter operation status control flag (RH)	Control the RH terminal of the inverter from PLC function
M9203	Inverter operation status control flag (RM)	Control the RM terminal of the inverter from PLC function
M9204	Inverter operation status control flag (RL)	Control the RL terminal of the inverter from PLC function
M9205	Inverter operation status control flag (JOG)	Control the JOG terminal of the inverter from PLC function
M9206	Inverter operation status control flag (RT)	Control the RT terminal of the inverter from PLC function
M9207	Inverter operation status control flag (AU)	Control the AU terminal of the inverter from PLC function
M9208	Inverter operation status control flag (CS)	Control the CS terminal of the inverter from PLC function
M9209	Inverter operation status control flag (MRS)	Control the MRS terminal of the inverter from PLC function
M9210	Inverter operation status control flag (STOP)	Control the STOP terminal of the inverter from PLC function



Number	Name	Description
M9211	Inverter operation status control flag (RES)	Control the RES terminal of the inverter from PLC function
M9216	Inverter status (RUN)	Inverter running
M9217	Inverter status (FWD)	Forward running
M9218	Inverter status (REV)	Reverse running
M9219	Inverter status (SU)	Up to frequency
M9220	Inverter status (OL)	Overload alarm
M9221	Inverter status (IPF)	Instantaneous power failure/undervoltage
M9222	Inverter status (FU)	Output frequency detection
M9223	Inverter status (ALM)	Fault output
M9224	Inverter status (LF)	Alarm output
M9225	Inverter status (DO0)	Status of output terminal function set in <i>Pr. 313</i> is stored *1
M9226	Inverter status (DO1)	Status of output terminal function set in <i>Pr. 314</i> is stored *1
M9227	Inverter status (DO2)	Status of output terminal function set in <i>Pr. 315</i> is stored *1
M9228	Inverter status (DO3)	Status of output terminal function set in <i>Pr. 316</i> is stored *1
M9229	Inverter status (DO4)	Status of output terminal function set in <i>Pr. 317</i> is stored *1
M9230	Inverter status (DO5)	Status of output terminal function set in <i>Pr. 318</i> is stored *1
M9231	Inverter status (DO6)	Status of output terminal function set in <i>Pr. 319</i> is stored *1
M9232	Inverter status (RA1)	Status of output terminal function set in <i>Pr. 320</i> is stored *1
M9233	Inverter status (RA2)	Status of output terminal function set in <i>Pr. 321</i> is stored *1
M9234	Inverter status (RA3)	Status of output terminal function set in <i>Pr. 322</i> is stored *1
M9255	Inverter operation status control selection	Select the inverter status control command from M9200 to M9211 or D9148. OFF: Special relay selection ON : Special register selection

\*1. Even if the FR-A7AY, FR-A7AR is not mounted, *Pr. 313* to *Pr. 322* are accessible during PLC function operation, and status of output terminal functions are stored in each device. (virtual output terminal)

## 1.9.5 Special registers

The special registers are data registers with special applications and therefore data should not be written to the special registers in the program.

Number	Name	Description	Page												
D9008	Self-diagnostic error	Stores the self-diagnosed error number in BIN. ( <i>Refer to page 26 for the error codes.</i> )	26												
D9010	Operation error step	Stores the step number in BIN, at which an instruction execution error occurred. After that, data is updated each time operation error occurs.	—												
D9011	Operation error step	Stores the step number in BIN, at which an instruction error occurred. Since data is stored into D9011 when M9011 turns from off to on, D9011 data is not updated unless M9011 is cleared by the user program.	—												
D9014	I/O control method	3 (fixed): Both input and output refreshes	—												
Special registers	D9015	CPU operating status <table border="1" style="margin-top: 10px;"> <tr> <td>Remote run/stop using GX Developer</td> <td>Invalid</td> <td>Remote run/stop using sequence parameter setting</td> <td>SQ signal ON/OFF</td> </tr> <tr> <td>0 RUN</td> <td></td> <td>0 RUN</td> <td>0 RUN</td> </tr> <tr> <td>1 STOP</td> <td></td> <td>1 STOP</td> <td>1 STOP</td> </tr> </table>	Remote run/stop using GX Developer	Invalid	Remote run/stop using sequence parameter setting	SQ signal ON/OFF	0 RUN		0 RUN	0 RUN	1 STOP		1 STOP	1 STOP	—
	Remote run/stop using GX Developer	Invalid	Remote run/stop using sequence parameter setting	SQ signal ON/OFF											
	0 RUN		0 RUN	0 RUN											
	1 STOP		1 STOP	1 STOP											
	D9016	Program number	Stores the number that indicates which sequence program is currently in execution. 1 (fixed): Main program (RAM)	—											
	D9017	Minimum scan time (10ms units)	Stores the scan time at every END that is smaller than D9017 data, i.e. stores the minimum scan time in BIN.	—											
	D9018	Scan time (10ms units)	Stores and updates the scan time at every END in BIN.	—											
	D9019	Maximum scan time (10ms units)	Stores the scan time at every END that is greater than D9019 data, i.e. stores the maximum scan time in BIN.	—											
	D9062 to D9093	Remote registers	Special registers for communication with the master station in CC-Link.	56											
	D9133	Output frequency monitor	Stores the current output frequency. 0.01Hz units	23											
D9134	Output current monitor	Stores the current output current. 0.01A/0.1A units *													
D9135	Output voltage monitor	Stores the current output voltage. 0.1V units													

\* The setting depends on the inverter capacities.

(FR-F720-02330-NA (FR-F740-01160-NA/EC) or lower/FR-F720-03160-NA (FR-F740-01800-NA/EC) or higher)



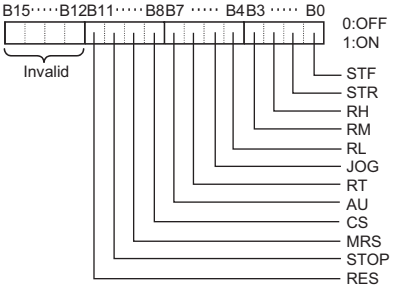

Number	Name	Description	Page
D9136	Error history 1, 2	Stores the errors that occurred in the inverter in order of occurrence.	24
D9137	Error history 3, 4		
D9138	Error history 5, 6		
D9139	Error history 7, 8		
D9140	Operation mode setting read	Stores the current operation mode.	27
D9141	Set frequency read (RAM)	Reads and stores the set frequency (RAM).	28
D9142	Set frequency read (EEPROM)	Reads and stores the set frequency (EEPROM).	28
D9143	Operation mode setting write	Sets a new operation mode.	30
D9144	Set frequency write (RAM)	Sets the running frequency (RAM).	31
D9145	Set frequency write (EEPROM)	Sets the running frequency (EEPROM).	32
D9146	Faults history batch clear	Write H9696 to clear the faults history.	33
D9147	Parameter clear	H9696 write: Parameter clear H9966 write: All clear H5A5A write: Parameter clear except communication parameters H55AA write: All clear except communication parameters During GX Developer communication, perform clearing by H5A5A or H55AA.	34
D9148	Inverter operation status control	Turn on/off the corresponding bits to control the inverter operation status. The initial value: All "0". When M9255 is off, this device does not function. 	35
D9149	Inverter operation status control enable/disable setting	Enable/disable the inverter operation status control using D9148 and M9200 to M9211 by turning on/off the corresponding bits. Bit image is the same as D9148. The initial value: All "0" (invalid) The SQ signal can be input from external terminals at any time. (The SQ signal cannot be controlled with bits from D9149.)	36

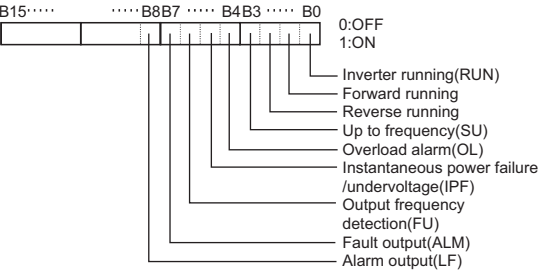
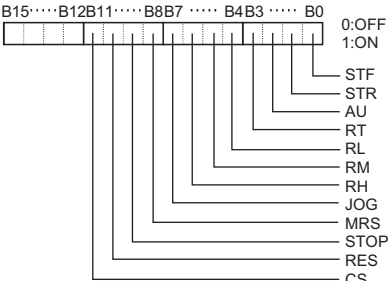

Number	Name	Description	Page
D9150	Inverter parameter access error	Stores the error No. when an error occurs because the data stored in the parameter or special register is not reflected on the inverter.	37
D9151	Inverter status	Stores the running status and operating status of the inverter. 	37
D9152	Frequency setting	0.01Hz units	—
D9153	Running speed	1(0.1)r/min units	—
D9155	Converter output voltage	0.1V units	—
D9156	Regenerative brake duty	0.1% units	—
D9157	Electronic thermal relay function load factor	0.1% units	—
D9158	Output current peak value	0.01A/0.1A units *	—
D9159	Converter output voltage peak value	0.1V units	—
D9160	Input power	0.01kW/0.1kW units *	—
D9161	Output power	0.01kW/0.1kW units *	—
D9162	Input terminal status	Input terminal status details 	—

\* The setting depends on the inverter capacities.

(FR-F720-02330-NA (FR-F740-01160-NA/EC) or lower/FR-F720-03160-NA (FR-F740-01800-NA/EC) or higher)



Special registers for control

Device Map

1

PLC FUNCTION

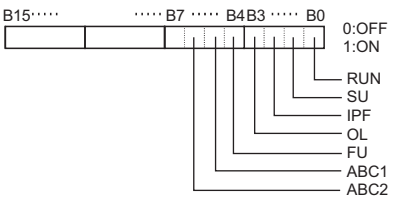
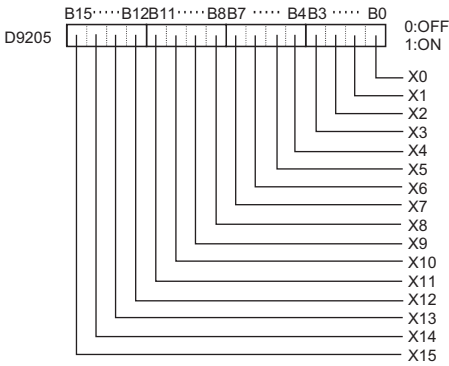

Number	Name	Description	Page
Special registers for control	D9163 Output terminal status	Output terminal status details 	—
	D9164 Load meter	0.1% units	—
	D9167 Cumulative energization time	1h units	—
	D9170 Actual operation time	1h unit	—
	D9171 Motor load factor	0.1% units	—
	D9172 Cumulative power	1kWh unit	—
	D9197 Power saving effect	Variable according to parameters	—
	D9198 Cumulative saving power		—
	D9199 PID set point	0.1% units	—
	D9200 PID measured value	0.1% units	—
	D9201 PID deviation	0.1% units	—
	D9205 Option input terminal status 1	The input status of the FR-A7AX is stored. All off (0) when an option is not fitted. 	—
	D9206 Option input terminal status 2		—

Number	Name	Description	Page	
Special registers for control	D9207	Option output terminal status	<p>The output status of the FR-A7AY, FR-A7AR is stored. All off (0) when an option is not fitted.</p>	—
	D9211	PTC thermistor resistance	Stores the PTC thermistor resistance at terminal 2 when PTC thermistor protection is active. (0.10kΩ increments)	—
	D9213	PID measured value 2	Stores the PID measured value (0.1% increments) (Monitoring is available even when PID control is not active.)	—
	D9214	User defined fault	An inverter fault can be initiated by setting a value between 16 and 20 in D9214.	38
	D9215	Monitor setting selection	Set D9215 to display the monitored values, which are set by D9216 to D9218, with decimal points.	39
	D9216	Monitor 1 setting	The PR command changes the first monitor to the D9216 monitor on FR-PU07-01.	39
	D9217	Monitor 2 setting	The PR command changes the second monitor to the D9217 monitor on FR-PU07-01.	39
	D9218	Monitor 3 setting	The PR command changes the third monitor to the D9218 monitor on FR-PU07-01.	39
	D9224	32-bit cumulative power (lower 16-bit)	1kWh	—
	D9225	32-bit cumulative power (upper 16-bit)	1kWh	—
	D9226	32-bit cumulative power (lower 16-bit)	0.01kWh/0.1kWh *	—
	D9227	32-bit cumulative power (upper 16-bit)	0.01kWh/0.1kWh *	—
	D9228	BACnet reception status	Displays BACnet reception status	—

\* The setting depends on the inverter capacities.  
 (FR-F720-02330-NA (FR-F740-01160-NA/EC) or lower/FR-F720-03160-NA (FR-F740-01800-NA/EC) or higher)



Number	Name	Description	Page
Special registers for control	D9234	Second parameter changing (RAM)	40, 42
	D9235	Second parameter changing (EEPROM)	
	D9241	Parameter number (RAM)	40, 42
	D9242	Parameter description (RAM)	
	D9243	Parameter number (EEPROM)	
	D9244	Parameter description (EEPROM)	
	D9245	Terminal 1 input	46
	D9246	Terminal 2 input	
	D9247	Terminal 4 input	
	D9248	PID set point / PID deviation	47
	D9249	PID measured value	
	D9250	PID manipulated variable	
	D9251	Terminal CA output	46
	D9252	Terminal AM output	
	D9253	AM0 output	
D9254	AM1 output		
D9255	PID operation control	47	

## 1.10 Inverter status monitoring, special registers for control

You can assign the data for grasping and changing the inverter's operation status to D9133 - D9147 and read/write them from the user sequence. (Refer to page 17 for the list.)

### 1.10.1 Data that can be read at all times

The following data can always be read. They are automatically refreshed every time the END instruction is executed.

#### (1) Operation monitor

The following data devices are always read-enabled (write-disabled) to allow you to monitor the output frequency, output current and output voltage of the inverter. Note the setting units.

Device No.	Name	Setting Unit	Data Example	Data Access Enable Condition
D9133	Output frequency monitor	0.01Hz	Device data 6000 → 60.00Hz	Always
D9134	Output current monitor	0.01A *1	Device data 200 → 2.00A	
		0.1A *2	Device data 200 → 20.0A	
D9135	Output voltage monitor	0.1V	Device data 1000 → 100.0V	

\*1 This setting unit is for FR-F720-02330-NA, FR-F740-01160-NA/EC or lower.

\*2 This setting unit is for FR-F720-03160-NA, FR-F740-01800-NA/EC or higher.

### CAUTION

**The frequency can be set in increments of 0.01Hz but actual operation is performed in increments of 0.1Hz.**



**(2) Faults history (fault codes and fault definitions)**

The inverter stores the fault codes of the faults that occurred.

The fault codes of up to eight faults are stored in the order as shown below and are always read-enabled (write-disabled).

<Fault code storing method details>

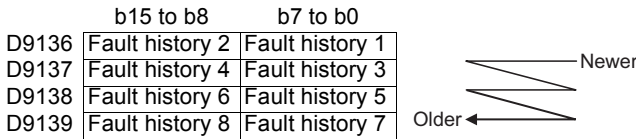

Data	Description
H00	No alarm
H10	E.OC1
H11	E.OC2
H12	E.OC3
H20	E.OV1
H21	E.OV2
H22	E.OV3
H30	E.THT
H31	E.THM
H40	E.FIN
H50	E.IPF
H51	E.UVT
H52	E.ILF
H60	E.OLT
H70	E.BE
H80	E.GF

Data	Description
H81	E.LF
H90	E.OHT
H91	E.PTC
HA0	E.OPT
HA1	E.OP1
HA2	E.OP2
HA4	E.16
HA5	E.17
HA6	E.18
HA7	E.19
HA8	E.20
HB0	E.PE
HB1	E.PUE
HB2	E.RET
HB3	E.PE2
HC0	E.CPU

Data	Description
HC1	E.CTE
HC2	E.P24
HC4	E.CDO
HC5	E.IOH
HC6	E.SER
HC7	E.AIE
HE4	E.LCI
HE5	E.PCH
HE6	E.PID
HF1	E.1
HF2	E.2
HF5	E.5
HF6	E.6
HF7	E.7
HFD	E.13

Refer to the *Inverter Instruction Manual* for faults history details.

**<Faults history read program example>**

The following program reads the latest faults history of the inverter to D0.

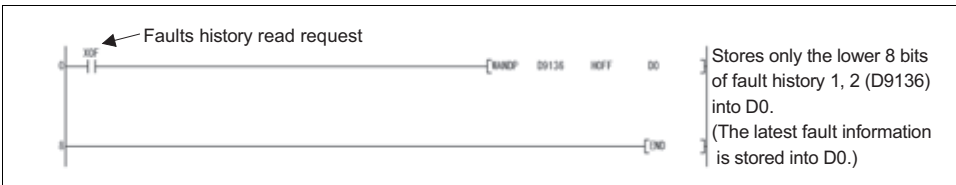

### (3) Fault clear signal (X51 signal)

The X51 signal cancels a fault without resetting the inverter when an inverter fault occurs.

The X51 signal cancels an inverter fault while the PLC function operation continues.

Enable the X51 signal by setting "51" in any of *Pr.178 to Pr.189 (Input terminal function selection)* in advance.

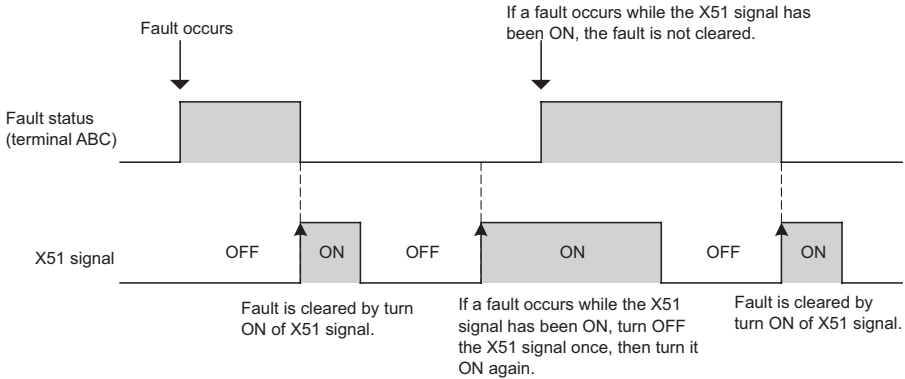

- Fault clear from the X51 signal is invalid during the retry operation (including the waiting time for a retry).  
(The X51 signal is available when the retry count excess (E.RET) occurs.)
- If a fault clear is performed, start commands from PU and communication are also cleared. (The statuses other than start command from communication remain the same at a fault clear.)

#### REMARKS

- E.CPU, E.P24, E.1, E.2, E.6, E.7, E.13, E.PE2 cannot be cleared by the X51 signal.

#### CAUTION

- The cumulative heat values of the electronic thermal relay and the regenerative brake are not cleared at a fault clear. A fault like E.THM, E.THT, E.BE may occur again.
- The inverter is in stop status immediately after a fault clear. However, the inverter restarts its operation after the fault is cleared when a start command has been ON.
- Pressing the STOP/RESET key on the operation panel or parameter unit activates a normal reset at a fault occurrence. Take caution not to press it by accident.
- Changing the terminal assignment using *Pr.178 to Pr.189 (Input terminal function selection)* may affect the other functions. Set parameters after confirming the function of each terminal.





#### **(4) Regarding the error No. and details of the self-diagnostic errors**

During execution of a sequence program, any of the following error No. is stored into D9008 due to an operation error.

At occurrence of a self-diagnostic error, the P.RUN indicator (LED) flickers.

<b>Error No.</b>	<b>Error Name</b>	<b>Details</b>
10	INSTRCT CODE ERR.	There is an instruction code that cannot be decoded. Unusable device is specified.
11	PARAMETER ERR	Main program capacity setting is over 4k step. Unusable function is set.
22	WDT ERR	Scan time is longer than the time that can be monitored by the watchdog timer.
24	END NOT EXECUTE	END instruction was not executed.

---

#### **CAUTION**

---

- 1. For the LD, AND, OR, logical comparison operation and OUT instructions, device checks are always made. For the other instructions (SET, RST, MOV, etc.), however, device checks are made when the execution condition holds.**
  - 2. Operation at error stop**  
The outputs (Y) are cleared.  
The other devices hold the states prior to an error stop.  
When you want to clear them, power off or reset (RES signal-ON (0.1s), then OFF) the inverter.
-

### 1.10.2 Data that are read by controlling (OFF to ON) the read command

You can read the operation mode and set frequency of the inverter.

Device No.	Name	Read Command	Write Completion	Data Access Enable Condition
D9140	Operation mode setting read	Y20	X20	Always
D9141	Set frequency read (RAM)	Y21	X21	
D9142	Set frequency read (EEPROM)	Y22	X22	

Data are stored into the above data devices as soon as the read completion turns from off to on after the read command has turned from off to on.

If the read command remains on, data is not refreshed. (Data is not updated.)

Turn the device off once, then on again to refresh data.

#### Data read timing chart

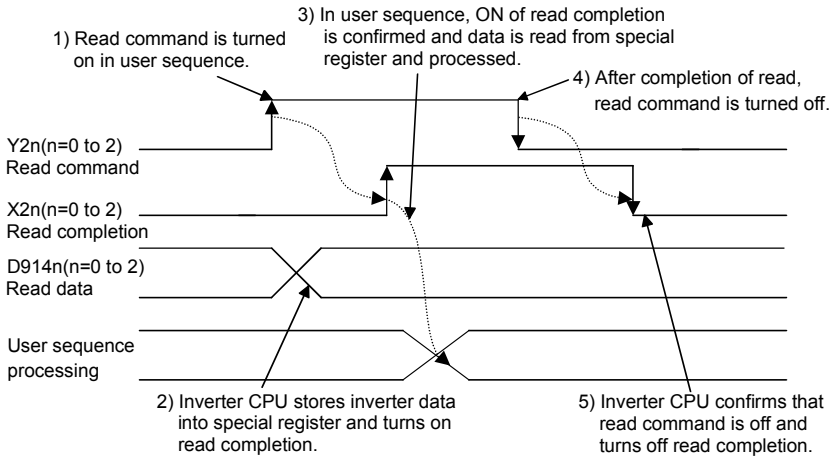

#### (1) Operation mode setting read (D9140)

Data Setting	Operation Mode
H0000	NET operation mode
H0001	External operation mode
H0002	PU operation mode

#### REMARKS

When the Pr. 79 Operation mode selection setting is other than "0", the operation mode is as set. However, when Pr. 79 = "3" or "4", the operation mode is "H0002" (PU operation mode).

#### <Operation mode setting read program example>

The following program reads the operation mode data to D0.

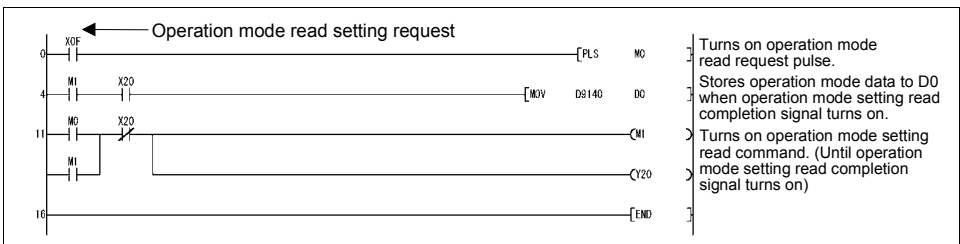

1  
PLC FUNCTION



**(2) Set frequency read (RAM) (D9141)**

The frequency set to the RAM is read to D9141. The unit is 0.01Hz.

(For example, 6000 indicates 60.00Hz.)

When the speed is set, the speed is either 1r/min or 0.1r/min.

**<Set frequency (RAM) read program example>**

The following program reads the set frequency (RAM) to D0.

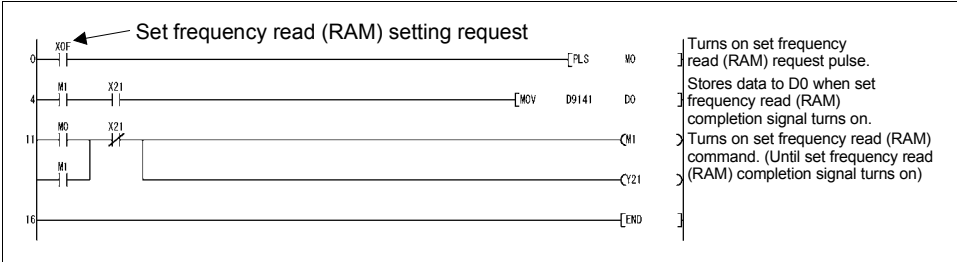

**REMARKS**

The read frequency is not the command value of the external signal.

**(3) Set frequency read (EEPROM) (D9142)**

The frequency set to the EEPROM is read to D9142. The unit is 0.01Hz.

(For example, 6000 indicates 60.00Hz.)

When the speed is set, the speed is either 1r/min or 0.1r/min.

**<Set frequency read (EEPROM) program example>**

The following program reads the set frequency (EEPROM) to D0.

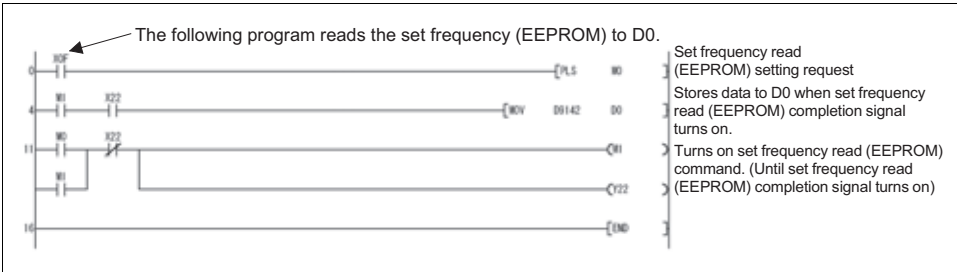

**REMARKS**

The read frequency is not the command value of the external signal.

### 1.10.3 How to write data by controlling (OFF to ON) the write command

You can write the operation mode and set frequency to the inverter, batch-clear the faults history, and clear all parameters.

Device No.	Name	Write Command	Write Completion	Data Access Enable Condition
D9143	Operation mode setting write	Y23	X23	<i>Pr. 79 = 0, 2</i>
D9144	Set frequency write (RAM)	Y24	X24	PU operation mode (PU LED on) or CC-Link operation mode (PU and EXT LEDs flicker slowly)
D9145	Set frequency write (EEPROM)	Y25	X25	
D9146	Faults history batch clear	Y26	X26	Always
D9147	All parameter clear	Y27	X27	As set in <i>Pr. 77</i>

The above data are written as soon as the write completion turns on after the write command has turned from off to on.

(Faults history batch clear (D9146) and all parameter clear (D9147) turn on at completion of clear.)

To write the data again, the write command must be turned off once, then on again.

#### Data write timing chart

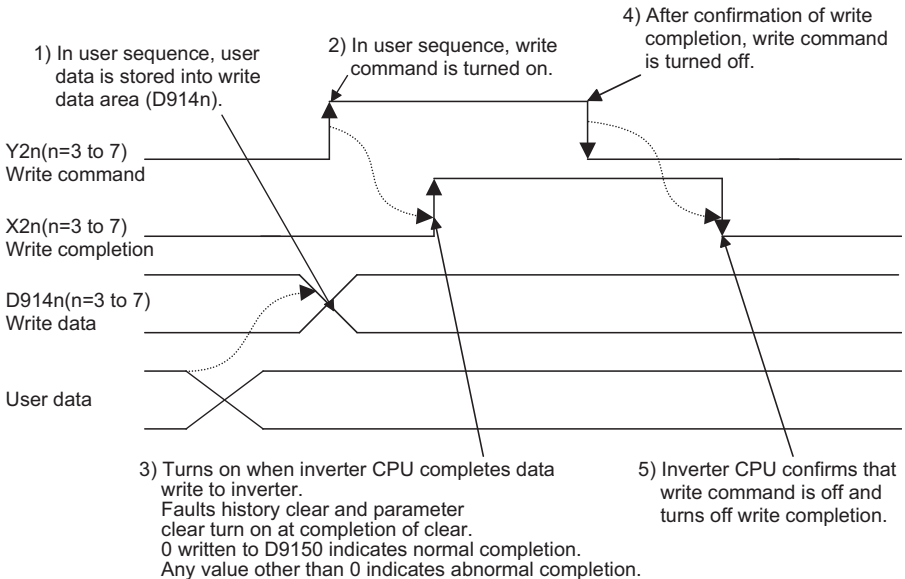



### (1) Operation mode setting write (D9143)

Data are as follows:

Data Setting	Operation Mode
H0000	NET operation mode
H0001	External operation mode
H0002	PU operation mode

The operation mode switching method is as shown below when the *Pr.79* Operation mode selection value is "0".

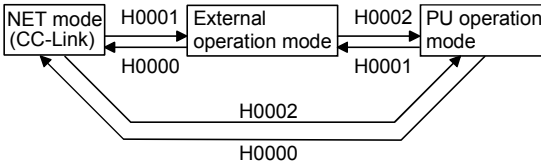

When *Pr. 79* =2, switching is performed as shown below.

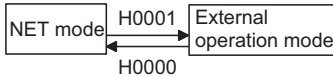

#### REMARKS

When *Pr. 79* is other than 0, the mode is fixed.

There are no restrictions on operation mode switching.

On normal completion of operation mode setting, the write completion signal (X23) turns on, and at the same time, 0 is set to D9150.

If the value written is other than H0000 to H0002 or write is performed during inverter operation, HFFFF is set to D9150 as soon as the write completion signal (X23) turns on, resulting in abnormal completion.

If abnormal completion occurs, the operation mode is not changed.

#### <Operation mode setting write program example>

The following program changes the operation mode to the NET mode.

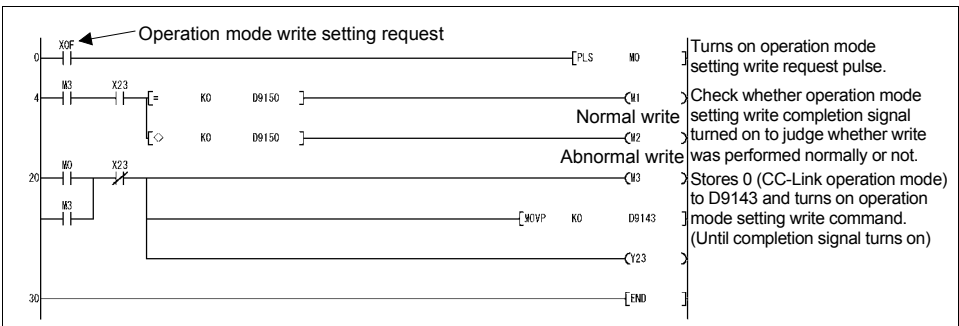

**(2) Set frequency write (RAM) (D9144)**

The D9144 data is written to the RAM as a set frequency. The unit is 0.01Hz.  
(For example, 6000 indicates 60.00Hz.)

When the speed is set, the speed is either 1r/min or 0.1r/min.

The range where the frequency can be set is 0 to 12000 (0 to 120.00Hz).

When the frequency setting is written normally, the write completion signal (X24) turns on, and at the same time, 0 is set to D9150.

If any value outside the range is written, HFFF is set to D9150 as soon as the write completion signal (X24) turns on, resulting in abnormal completion. If abnormal completion occurs, the set frequency is not changed.

**POINT**

- The frequency can be set in the PU operation mode and NET operation mode. Refer to the *inverter instruction manual*.

**<Set frequency write (RAM) program example>**

The following program changes the set frequency (RAM) to 30Hz.

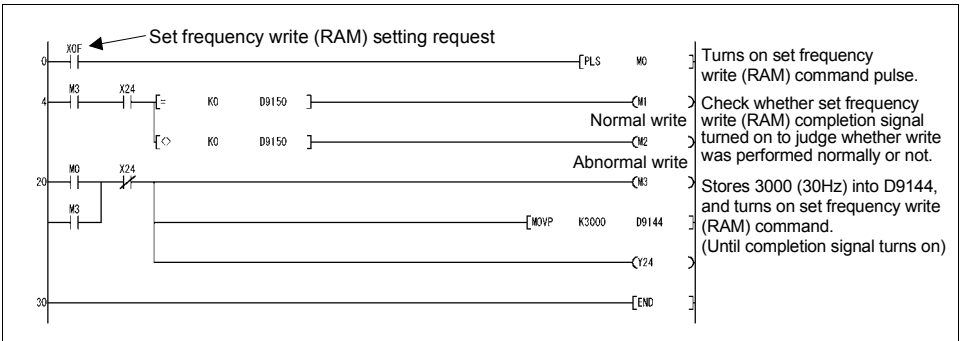



### (3) Set frequency write (EEPROM) (D9145)

The D9145 data is written to the EEPROM as a set frequency. The unit is 0.01Hz. (For example, 6000 indicates 60.00Hz.)

When the speed is set, the speed is either 1r/min or 0.1r/min.

The range where the frequency can be set is 0 to 12000 (0 to 120.00Hz).

When the frequency setting is written normally, the write completion signal (X25) turns on, and at the same time, 0 is set to D9150.

If any value outside the range is written, HFFF is set to D9150 as soon as the write completion signal (X25) turns on, resulting in abnormal completion. If abnormal completion occurs, the set frequency is not changed.

#### POINT

- **Setting is enabled in the PU operation mode and NET operation mode.**  
(Refer to the *Inverter instruction manual*.)

#### <Set frequency write (EEPROM) program example>

The following program changes the set frequency (EEPROM) to 10Hz.

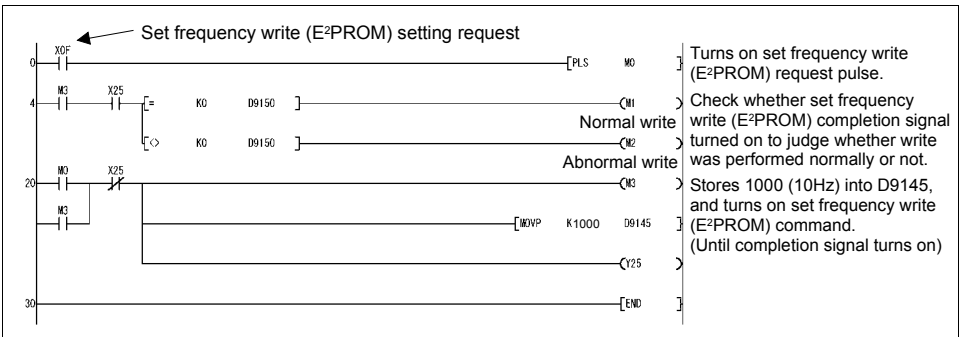

#### CAUTION

**When rewriting the set frequency frequently, use device D9144 "set frequency (RAM)". There are restrictions on the number of write times of the EEPROM. (Approximately 100,000 times)**

**(4) Faults history batch clear (D9146)**

Writing H9696 to D9146 batch-clears the faults history.

At completion of clear, the write completion signal (X26) turns on, and at the same time, 0 is set to D9150. If any value outside the setting range is written or write is performed during inverter operation, HFFFF is set to D9150 as soon as the write completion signal (X26) turns on, resulting in abnormal completion.

If abnormal completion occurs, the faults history are not cleared.

**<Faults history batch clear program example>**

The following program batch-clears the alarm history.

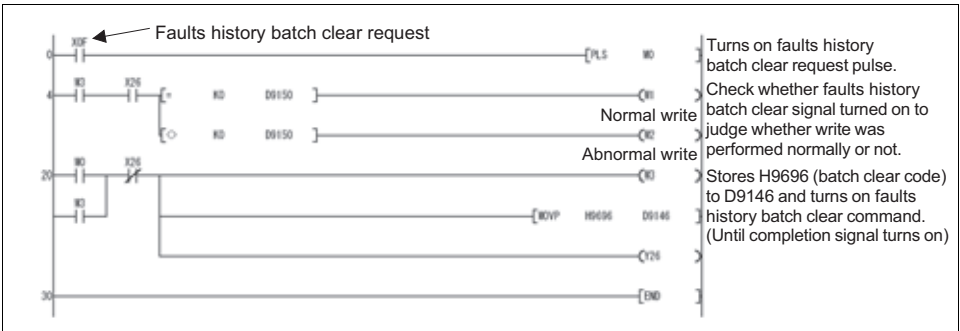





### (5) Parameter clear (D9147)

Writing H9696 or H9966 to D9147 clears all parameters. Writing H5A5A or H55AA to D9147 clears the parameters other than the communication parameters (Refer to the *Inverter Instruction Manual*).

Device No.	Setting	Communication Pr.	Other Pr. *	Details
D9147	H9696	○	○	Terminal functions are not cleared.
	H9966	○	○	Terminal functions are cleared.
	H5A5A	×	○	Terminal functions are not cleared.
	H55AA	×	○	Terminal functions are cleared.

\* Pr. 75 is not cleared

At completion of clear, the write completion signal (X27) turns on, and at the same time, 0 is set to D9150. If any value outside the setting range is written or write is performed during inverter operation, HFFFF is set to D9150 as soon as the write completion signal (X27) turns on, resulting in abnormal completion. If abnormal completion occurs, the parameters are not cleared.

#### REMARKS

Check the terminal function parameters and communication-related parameters in the parameter list (Refer to the *Inverter Instruction Manual*).

#### POINT

**Setting is enabled in the PU operation mode and NET operation mode.** Refer to the *inverter Instruction Manual*.

#### <All parameter clear program example>

The following program clears all parameters.

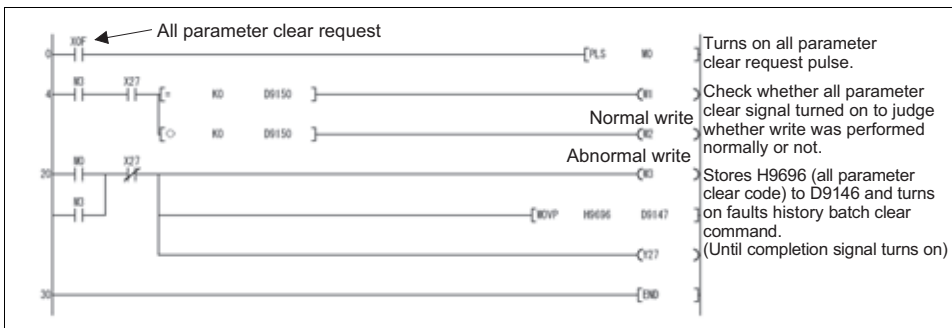

#### CAUTION

- Executing parameter clear/all clear clears the setting value of communication parameter, which disables communication with GX Developer.

#### ◆ Related device ◆

Device D9150: Parameter access error code (refer to page 37)

### 1.10.4 Inverter operation status control

Device No.	Name	Data Access Enable Condition
D9148	Inverter operation status control	Always
D9149	Inverter operation status control enable/disable	Note that this function is enabled in the external/NET operation mode. (Not enabled in the PU operation mode.)

#### (1) Inverter operation status control (D9148)

Device for inverter operation status control. The operation of the inverter can be controlled by turning on/off (1, 0) bits b0 to b11 of D9148.

All bits are factory-set to "0".

Example: When 5 is set to D9148, bits b0 and b2 are 1 (ON), and STF and RH therefore turn on to give a high-speed forward rotation command.

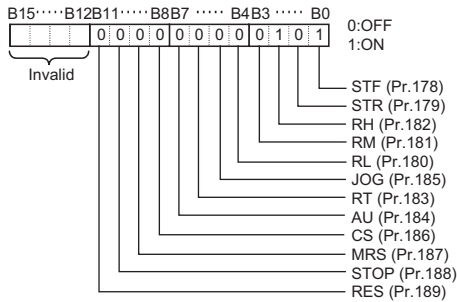

#### CAUTION

**As in the external input terminals, functions can be assigned to the bits of D9148 using Pr.178 to Pr.189. However, no function can be assigned to SQ (sequence RUN setting: 50).**



## (2) Inverter operation status control enable/disable setting (D9149)

You can enable or disable D9148 "inverter operation status control". The controls of the corresponding bits of D9148 are enabled by turning on/off (1, 0) bits b0 to b11 of D9149. All bits are factory-set to "0".

Example: When H1F is set to D9149, bits b0 to b11 are 1 (ON), the external terminal inputs are therefore all disabled, and operation control using the inverter operation status control (D9148) can be performed.

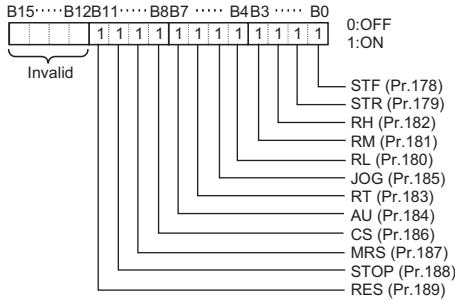

### CAUTION

- When D9148 "inverter operation status control" is enabled using D9149, the control performed by external terminal inputs and the control performed by CC-Link remote inputs are disabled for the enabled bits. (Same as when "No functions" are set to Pr.178 to Pr.189.)
- When the terminal is made valid from PLC function, control from external terminal is made invalid.
- The SQ signal can be input from external terminals at any time. (The SQ signal cannot be controlled with bits from D9149.)

### <Operation command setting program example>

The following program example runs the inverter at high speed in forward rotation direction.

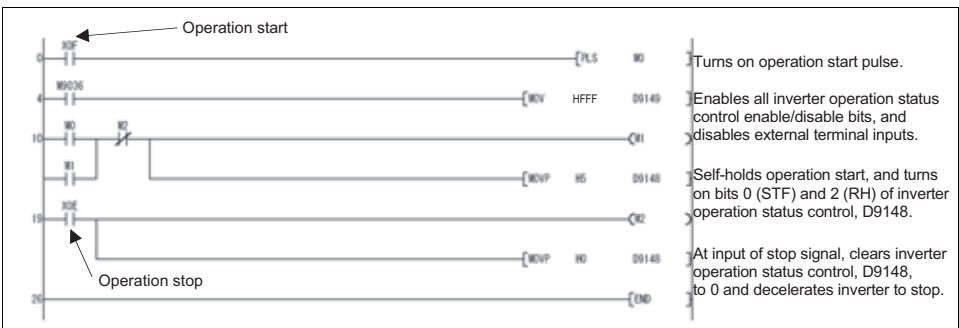

### 1.10.5 Inverter parameter access error (D9150)

Device No.	Name	Data Access Enable Condition
D9150	Inverter parameter access error	Always

If any value outside the setting range is written during parameter write, set frequency write, parameter clear, etc. from the sequence program of the inverter, or if write is performed when write is disabled, a write alarm occurs and the corresponding alarm code is stored into D9150.

#### <Parameter>

The parameter No. + H8000 is stored into D9150.

Example: If an error occurs during write of *Pr.0 Torque boost*, H8000 (H0 + H8000) is stored into D9150.

If an error occurs during write of *Pr.10 DC injection brake operation frequency*, H800A is stored into D9150.

#### <Operation mode, set frequency, faults history batch clear, all parameter clear>

HFFFF is stored into D9150. (Normal 0)

#### POINT

**If write is completed normally after error occurrence, D9150 is not cleared (D9150 data is held at error occurrence). When using D9150 to stop operation, etc., the user must clear it.**

### 1.10.6 Inverter status (D9151)

Device No.	Name	Data Access Enable Condition
D9151	Inverter status	Always

The running status and operating status of the inverter are stored.

The corresponding bits are set according to the inverter status.

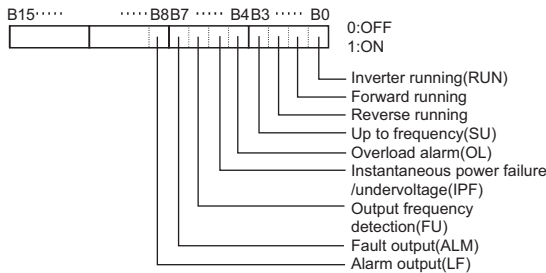



### **1.10.7 User defined fault (D9214)**

An inverter fault can be initiated by setting a value between 16 and 20 in D9214. The inverter stops when a fault occurs.

The settings other than 16 to 20 are invalid. The setting is also invalid when *Pr.414* ≠ "1."

Initiated faults are recognized as E.16 to E.20 on the inverter side.

### 1.10.8 Monitor setting selection(D9215 to D9218)

Set the names and units of monitored items for each of D9216, D9217, and D9218 using the PR command. (Refer to page 193.)

To display the names and the units of the monitored items, which are set by D9216 to D9218, on FR-PU07-01, set "40, 41, or 42" in Pr.774 to Pr.776. (Refer to the *Instruction Manual of the inverter* for the details of Pr.774 to Pr.776.)

Device	Monitored item	Pr.774 to Pr.776 setting
D9216	User monitor 1	40
D9217	User monitor 2	41
D9218	User monitor 3	42

Set D9215 as shown below to display the monitored values, which are set by D9216 to D9218, with decimal points.

#### <Setting of D9215>

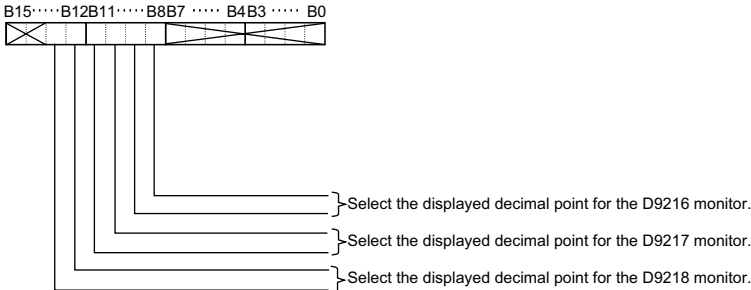

\* The bits other than the ones above are ignored.

#### <Displayed decimal point setting>

bn+1	bn	Unit
0	0	1 increment (without decimal point)
0	1	0.1 increment
1	0	0.01 increment
1	1	0.001 increment

Setting example:

- To display the D9216 monitor without a decimal point in the first monitor
  - Set H0000 in D9215.
  - Set "40" in Pr.774.
- To display the D9216 monitor in 0.1 increments in the first monitor and the D9218 monitor in 0.001 increments in the second monitor
  - Set H3100 in D9215.
  - Set "40" in Pr.774 and "42" in Pr.775.



## 1.11 Inverter parameter read/write method

### 1.11.1 Reading the inverter parameters

Device No.	Name	Command	Completion	Data Access Enable Condition (Operation mode)
D9241	Parameter number (RAM)	Y28	X28	Always
D9242	Parameter description (RAM)			
D9234	Second parameter changing (RAM)			
D9243	Parameter number (EEPROM)	Y2A	X2A	
D9244	Parameter description (EEPROM)			
D9235	Second parameter changing (EEPROM)			

When reading the parameter, the parameter description is stored to D9242(D9244) by storing the parameter number to D9241(D9243) and turning Y28 (Y2A) on. When reading is completed, X28 (X2A) turns ON to notify the completion. (The device number within parentheses is used to read the parameter setting value from EEPROM.)

When reading the calibration parameter (*Pr. 902 to Pr. 939*), set the following value to D9234 (D9235) to read each calibration parameter value.

- 0: Setting value (Frequency)
- 1: Parameter-set analog value
- 2: Analog value input from terminal

When access error occurs such as "parameter does not exist", value obtained by adding the parameter number and 8000H is stored to D9150. (*Refer to page 37*)

## Inverter parameter data read timing chart

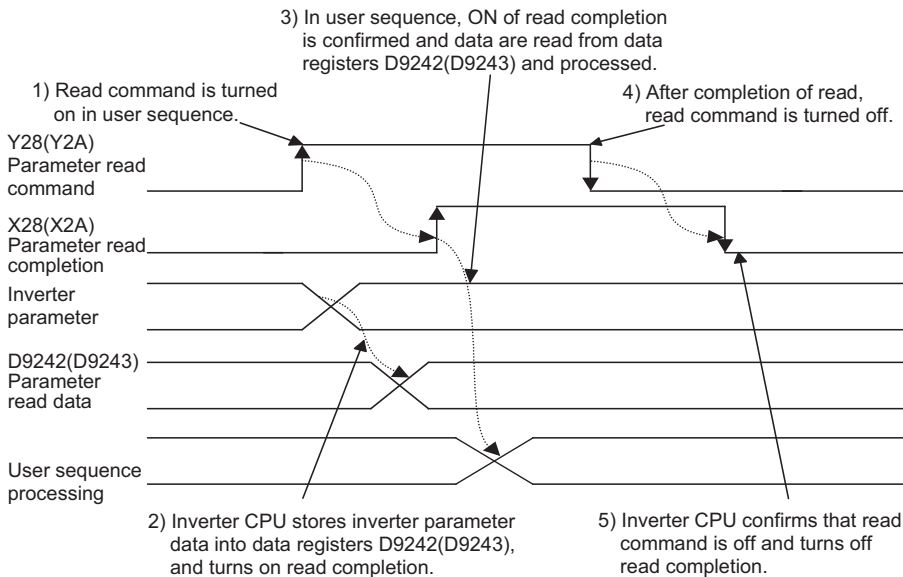





## 1.11.2 Writing the inverter parameters

Device No.	Name	Command	Completion	Data Access Enable Condition (Operation mode)
D9241	Parameter number (RAM)	Y29	X29	PU, NET operation mode (as in Pr.77)
D9242	Parameter description (RAM)			
D9234	Second parameter changing (RAM)			
D9243	Parameter number (EEPROM)	Y2B	X2B	
D9244	Parameter description (EEPROM)			
D9235	Second parameter changing (EEPROM)			

Parameter writing is performed when the parameter number is stored to D9241 (D9243) and parameter writing value to D9242 (D9244), and turns ON the Y29 (Y2B). When writing is completed, X29 (X2B) turns ON to notify the completion. (The device number within parentheses is used to write the parameter setting value to EEPROM.) When writing the calibration parameter (*Pr. 902* to *Pr. 939*), set the following value to D9234 (D9235) to write each calibration parameter value.

- 0: Setting value (Frequency)
- 1: Parameter-set analog value
- 2: Analog value input from terminal

As soon as the inverter parameter write completion (X29 (RAM) or X2B (EEPROM)) turns on, 0 is set to D9150 on normal completion.

If an error occurs during access to the parameters, e.g. if any value outside the setting range is written or write is performed during inverter operation, the value of parameter No. + H8000 is set to D9150 as soon as the write completion signal (X29 (RAM) or X2B (EEPROM)) turns on, resulting in abnormal completion. If abnormal completion occurs, the parameters are not written. (For example, if an error occurs in the torque boost, H8000 is written to D9150.)

For whether inverter parameter write can be performed or not, refer to *Pr.77 Parameter write selection*.

### POINT

**Inverter parameter write must be performed in the PU operation mode or NET operation mode. (Refer to the *Inverter Instruction Manual*.)**

## Inverter parameter data write timing chart

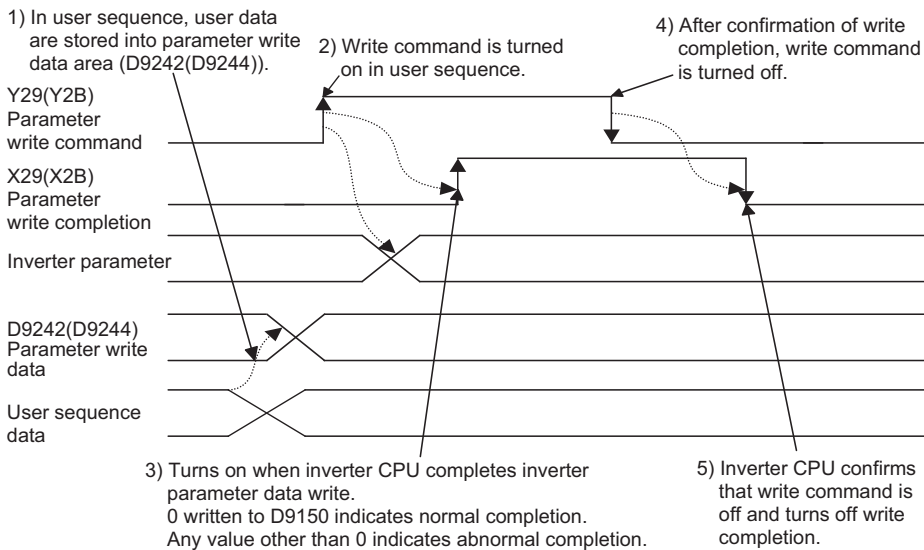



## 1.12 User area read/write method

Inverter parameters *Pr.506 to Pr.515, Pr.826 to Pr.865* can be used as user parameters. Since this parameter area and the devices used with the PLC function, D110 to D159, are accessible to each other, the values set in *Pr.506 to Pr.515, Pr.826 to Pr.865* can be used in a sequence program. The result of operation performed in the sequence program can also be monitored using *Pr.506 to Pr.515, Pr.826 to Pr.865*.

Device No.	Inverter Parameter No.	Name	Initial Value	Setting Range	Minimum Setting Unit	Data Access
D110 to D159	506 to 515, 826 to 865	User parameters	0	0 to 65535	1	Always enabled



### POINT

#### Example of using the user parameter area

When the timing is to be changed for machine adjustment using D110 that stores the timer setting, setting *Pr. 506* without modifying the program enters the set data into D110, enabling adjustment.

### 1.12.1 User parameter read/write method

User parameter (*Pr.506 to Pr.515, Pr.826 to Pr.865*) and device (D110 to D159) data can be read/written freely. Data transfer between *Pr.506 to Pr.515, Pr.826 to Pr.865* and D110 to D159 is executed automatically.

#### 1) User parameter write processing and device write processing

When values are written to *Pr.506 to Pr.515, Pr.826 to Pr.865* using the FR-PU04/FR-PU07(-01) or computer link communication, they are written to the parameter storing RAM area and EEPROM area, and further to D110 to D159 simultaneously.

#### 2) User parameter read processing and device write processing.

When values are written to D110 to D159 from the PLC function side, they are written to the parameter storing RAM area (*Pr.506 to Pr.515, Pr.826 to Pr.865*) and read using the FR-PU04/FR-PU07(-01) or communication (RS-485 or communication option). (Since data are not written to the EEPROM, making power-on reset returns the data to the original values.)

#### 3) Processing performed at inverter reset or power restoration

When the inverter is reset, the *Pr.506 to Pr.515, Pr.826 to Pr.865* values stored in the EEPROM are transferred to the RAM area and D110 to D159.

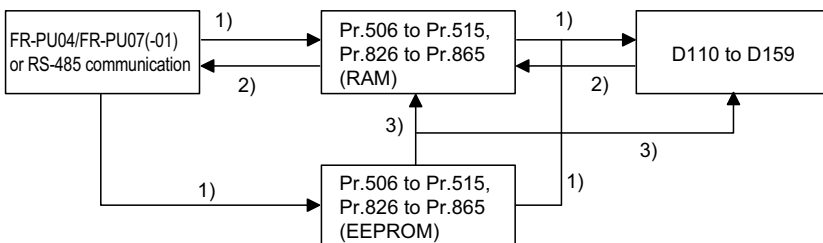



### 1.12.2 User parameter EEPROM read/write method

Device No.	Parameter No.	Name	Command	Completion	Data Access
D110 to D159	506 to 515, 826 to 865	User Parameter read (EEPROM/RAM)	Y2E	X2E	Always enabled
		User Parameter write (EEPROM/RAM)	Y2F	X2F	

After turning off the read/write command and on again, turning on the read/write completion enables read/write of user parameter from RAM and EEPROM.

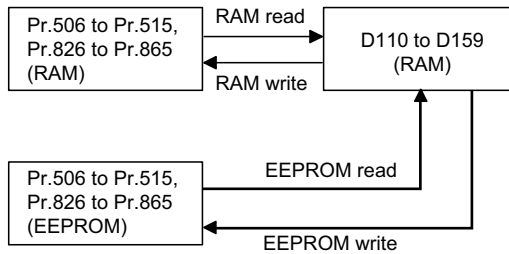
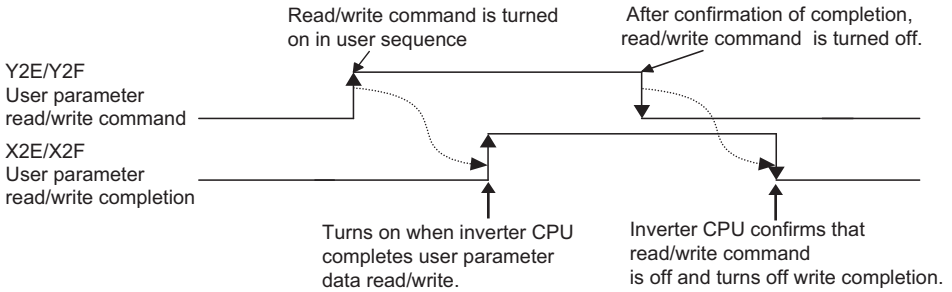

#### REMARKS

- Even if a user parameter is changed by direct write (RAM value write), executing data read from EEPROM changes a RAM value to the value stored in EEPROM.
- When *Pr.342 Communication EEPROM write selection* = "1", a RAM value is written/read.



## 1.13 Analog I/O function

### 1.13.1 Analog input

Analog input value of terminal 1, 2, 4 can be read from D9245 to D9247.

Device No.	Terminal Name	Setting Unit	Data Access Enable Condition
D9245	Terminal 1 input	0.1%	Always
D9246	Terminal 2 input	0.1%	
D9247	Terminal 4 input	0.1%	

Actual read processing is performed at the END processing of the sequence.

#### REMARKS

Full-scale value of analog input is determined by the setting of *Pr. 73 Analog input selection*, *Pr. 267 Terminal 4 input selection*. Refer to the *Instruction Manual of the inverter*.

### 1.13.2 Analog output

Analog output from each terminal can be performed by setting value on D9251 to D9254.

Output from PLC function can be performed by setting "70" in output signal selection parameters of each terminal (terminal CA: *Pr. 54*, terminal AM: *Pr. 158*, terminal AM0, AM1: *Pr. 306*, *Pr. 310*).

Device No.	Terminal Name	Setting Unit	Data Access Enable Condition
D9251	Terminal CA	0.1%	Always
D9252	Terminal AM	0.1%	
D9253	Terminal AM0 (FR-A7AY)	0.1%	
D9254	Terminal AM1 (FR-A7AY)	0.1%	

Actual read processing is performed at the END processing of the sequence.



## 1.14 PID control

With PLC function, PID set point/PID deviation value, PID measured value can be set by setting *Pr. 128*.

Performing the PID operation using the value of D9248 and D9249 as PID set point/PID deviation value, PID measured value, manipulated variable is stored to D9250.

When performing PID control with PLC function, "1" is set on D9255 instead of X14 signal.

When *Pr. 128* = "70, 71, 80, 81", PID control calculation does not start until actual start. Therefore setting 1 to D9255 does not change the manipulated variable D9250, and D9250 remains 0.

When *Pr. 128* = "90, 91, 100, 101", setting 1 to D9255 will start the PID calculation, and the calculation is applied to the manipulated variable D9250.

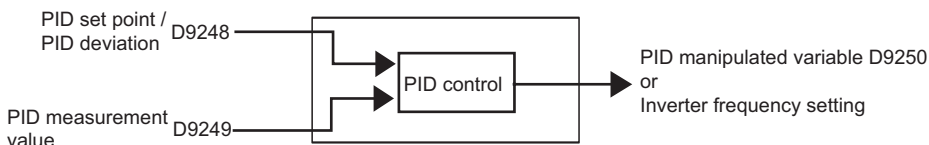

Parameter	Name	Initial Value	Setting Range	Description	
128	PID action selection	10	10, 11, 20, 21, 40, 41, 50, 51, 60, 61, 110, 111, 120, 121, 140, 141	For details, refer to <i>the Instruction Manual of the inverter</i> .	
			70	PID reverse action	Deviation value signal input (PLC function)
			71	PID forward action	
			80	PID reverse action	Measured value, set point input (PLC function)
			81	PID forward action	
			90	PID reverse action	Deviation value signal input (PLC function) Not reflected to the inverter output frequency
			91	PID forward action	
			100	PID reverse action	Measured value, set point input (PLC function) Not reflected to the inverter output frequency
101	PID forward action				



Device No.	Name	Setting Range	Description
D9248	PID set point / PID deviation	Set point: 0 to 100%* Deviation value: -100 to 100%	Set the PID set point or PID deviation (0.01% increments*)
D9249	PID measured value	0 to 100%*	Set the PID measurement value (0.01% increments*)
D9250	PID manipulated variable	-100 to 100%	Stores the PID manipulated variable (0.01% increments)
D9255	PID operation control	0	PID operation stop
		1	PID operation start

\* When both *Pr.934* and *Pr.935* are set to a value other than "9999," the set point of D9248 and the measured value of D9249 are set with coefficients. The setting range for the devices are from the smaller coefficient to the larger coefficient of *Pr.934* and *Pr.935*.

(Refer to the *Instruction Manual of the inverter* for the details of *Pr.934* and *Pr.935*.)

---

### CAUTION

---

- The PID set point/PID deviation value of D9248 automatically switches over by *Pr. 128* setting.
  - If *Pr. 128* is set to deviation input (70, 71, 90, 91), setting value of PID measured value (D9249) is made invalid.
  - Operates in the maximum value (the minimum value) of the setting range if the value outside the range is set.
-



## 1.15 Inverter operation lock mode setting

You can disable a sequence program from being executed until the sequence program execution key is set to RUN (SQ signal is turned on).

### POINT

When you want to perform only inverter operation without using the PLC function, set "0" (inverter start signal enable) in this parameter.

Parameter	Name	Initial Setting	Setting Range	Minimum Setting Unit
415	Inverter operation lock mode setting	0	0, 1	1

Setting	Description
0	The inverter start signal is made valid regardless of the sequence program execution key.
1	The inverter start signal is made valid only when the sequence program execution key is set to RUN (SQ signal is turned on). When the sequence program execution key is in the STOP position (SQ signal is off), the inverter does not start if the inverter start signal STF or STR is turned on. (If the key is switched from RUN to STOP during inverter operation, the inverter is decelerated to a stop.)

### CAUTION

- Independently of the *Pr. 77* setting, this parameter value cannot be rewritten during inverter operation.
- During automatic operation performed using D9148(or M9200 to M9211) in the sequence program, the inverter comes to a stop when the sequence is set to a STOP status with "1" set in *Pr.415*. However, when "0" is set in *Pr.415*, the device data are held and the operation status does not change if the sequence is set to a STOP status. (Inverter operation is continued.)

### REMARKS

This parameter setting is also valid for the start signal from the operation panel or FR-PU04/FR-PU07(-01).





## 1.16 Clearing of Flash Memory for PLC Function

Setting 9696 in *Pr.498* clears flash memory used for PLC function.

Parameter Number	Name	Initial Setting	Setting Range	Description
498	PLC function flash memory clear	0	0 to 9999	9696: Flash memory clear Other than 9696: Flash memory is not cleared

- For *Pr.498*, always 0 is read independently of the written value.
- When you can not remember a key word for PLC function (register function by GX developer), clearing flash memory using *Pr.498* cancels the key word.
- Clearing flash memory is enabled only when the PLC function is invalid (*Pr.414* = 0).

### CAUTION

- Since executing this function clears a program of the PLC function and all PLC parameters, write a program and PLC parameters again.
- As it takes about 5s for clearing of flash memory, do not perform inverter reset nor switch power off for 5s after writing 9696 in *Pr.498*. If the inverter reset or power off occurs in 5s, write 9696 in *Pr.498* again.

# 2. CC-Link COMMUNICATION

2.1	System configuration.....	52
2.2	CC-Link parameters .....	55
2.3	CC-Link I/O specifications .....	56
2.4	Buffer memory .....	63

Chapter 1

Chapter 2

Chapter 3

Chapter 4



## 2.1 System configuration

### 2.1.1 System configuration example

(1) PLC side

Mount the "control & communication link system master/local module" on the main base unit or extension base unit of the PLC CPU that will act as the master station.

(2) Connect the PLC CC-Link module master station and inverters by CC-Link dedicated cables.

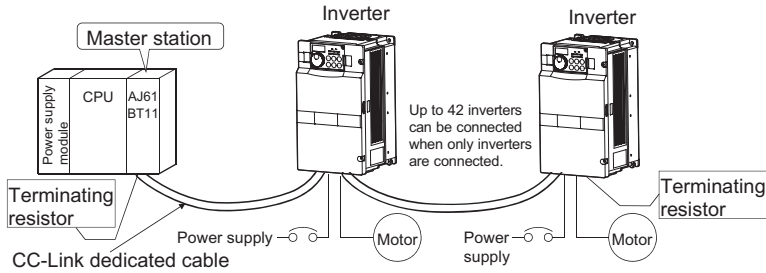

#### REMARKS

Refer to the FR-A7NC Instruction Manual for the CC-Link communication wiring and CC-Link cables.

## 2.1.2 Function block diagram

How I/O data are transferred to/from the inverter in CC-Link will be described using function blocks.

- (1) Between the master station and inverter in the CC-Link system, link refresh is always made at 3.5 to 18ms (512 points).
- (2) I/O refresh and master station's sequence program are executed asynchronously.
- (3) Data read from the inverter is read from the buffer memory of the CC-Link system master/local module using the FROM instruction.
- (4) Data to be written to the inverter is written to the buffer memory of the CC-Link system master/local module using the TO instruction.

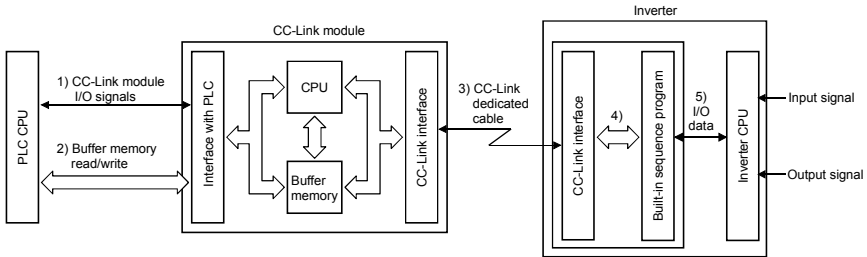

- 1) I/O signals assigned to the CC-Link system master/local module. These signals are used to make communication between the PLC CPU and CC-Link system master/local module.
- 2) Input data from the inverter can be read, and output data from the inverter can be written. Buffer memory read/write is performed using the FROM/TO instruction of the sequence program. *Refer to page 63* for details of the buffer memory.
- 3) PLC link start is commanded from the sequence program. After PLC link has started, link refresh is always made asynchronously with the sequence program execution.
- 4) I/O data are transferred between the CC-Link system master/local module and inverter CPU via the sequence program.
- 5) I/O data are transferred between the inverter CPU and sequence program. (5) indicates the operation performed when CC-Link is not used, and is irrelevant to 1) to 4).)

### REMARKS

Programs cannot be read/written via CC-Link communication.



**POINT**

The difference between CC-Link communication (*Pr: 544 = 100, 112, 114, 118*) with PLC function and normal CC-Link communication (*Pr: 544 = 1, 2, 12, 14, 18*) is indicated below.

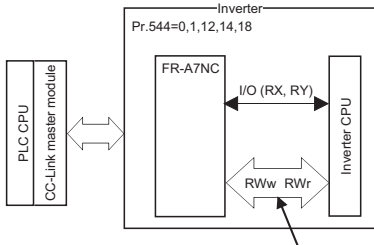

Parameter read/write, monitor, operation commands, etc. have been assigned in advance.

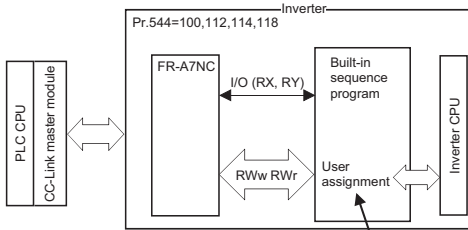

Using built-in sequence program, parameters, monitor, etc. must be assigned.  
 Other data read/write, etc. can be assigned freely as user areas.  
 \*Operation and speed commands have been assigned in advance.

## 2.2 CC-Link parameters

### 2.2.1 CC-Link extended setting (Pr. 544)

Remote register function can be extended.

Parameter Number	Name	Initial Value	Setting Range	CC-Link Ver.	Description
544	CC-Link extended setting	0	0	1	Occupies one station (FR-A5NC compatible) *1
			1		Occupies one station
			12 *2	2	Occupies one station double
			14 *2		Occupies one station quadruple
			18 *2		Occupies one station octuple
			100	1	Occupies one station (PLC function)
			112 *2	2	Occupies one station double (PLC function)
			114 *2		Occupies one station quadruple (PLC function)
			118 *2		Occupies one station octuple (PLC function)

\*1 The program used for conventional series inverter (FR-A5NC) can be used.

\*2 When using double, quadruple and octuple settings of the CC-Link Ver.2, station data of the master station must be set to double, quadruple and octuple also. (If the master station is CC-Link Ver.1 compatible station, the above setting can not be made.)

#### REMARKS

The setting change is reflected after an inverter reset.



## 2.3 CC-Link I/O specifications

### 2.3.1 I/O signal when CC-Link Ver.1 one station is occupied (Pr. 544 = 100)

The device points usable in CC-Link communication are 32 input (RX) points (16 points are available for PLC function), 32 output (RY) points (16 points are available for PLC function), 4 remote register (RWr) points and 4 remote register (RWw) points.

#### (1) Remote I/O

PLC Function Device No.	Remote Output Device No.	Signal	PLC Function Device No.	Remote Input Device No.	Signal
X30	RYn0	Forward rotation command	Y30	RXn0	Forward running
X31	RYn1	Reverse rotation command	Y31	RXn1	Reverse running
X32	RYn2	High-speed operation command (terminal RH function) *1	Y32	RXn2	Running (terminal RUN function) *2
X33	RYn3	Middle-speed operation command (terminal RM function) *1	Y33	RXn3	Up to frequency (terminal SU function) *2
X34	RYn4	Low-speed operation command (terminal RL function) *1	Y34	RXn4	Overload alarm (terminal OL function) *2
X35	RYn5	Jog operation command (terminal JOG function) *1	Y35	RXn5	Instantaneous power failure (terminal IPF function) *2
X36	RYn6	Second function selection (terminal RT function) *1	Y36	RXn6	Frequency detection (terminal FU function) *2
X37	RYn7	Current input selection (terminal AU function) *1	Y37	RXn7	Error (terminal ABC1 function) *2
X38	RYn8	Selection of automatic restart after instantaneous power failure (terminal CS function) *1	Y38	RXn8	— (terminal ABC2 function) *2
X39	RYn9	Output stop	Y39	RXn9	Pr. 313 assignment function (DO0)
X3A	RYnA	Start self-holding selection (terminal STOP function) *1	Y3A	RXnA	Pr. 314 assignment function (DO1)
X3B	RYnB	Reset (terminal RES function) *1	Y3B	RXnB	Pr. 315 assignment function (DO2)
X3C	RYnC	General-purpose remote input available in PLC function	Y3C	RXnC	General-purpose remote input available in PLC function
X3D	RYnD		Y3D	RXnD	
X3E	RYnE		Y3E	RXnE	
X3F	RYnF		Y3F	RXnF	
—	RY(n+1)0 to RY(n+1)7	Reserved	—	RX(n+1)0 to RX(n+1)7	Reserved
—	RY(n+1)8	Not used (initial data process completion flag)	—	RX(n+1)8	Not used (initial data process request flag)
—	RY(n+1)9	Not used (initial data process request flag)	—	RX(n+1)9	Not used (initial data process completion flag)
—	RY(n+1)A	Error reset request flag	—	RX(n+1)A	Error status flag
—	RY(n+1)B to RY(n+1)F	Reserved	—	RX(n+1)B	Remote station ready
			—	RX(n+1)C to RX(n+1)F	Reserved

("n" indicates a value determined according to the station number setting.)

- \*1 Signal names are initial values. Using *Pr. 180 to Pr. 186, Pr. 188, and Pr. 189*, you can change input signal functions. Signals of the RYn0, RYn1, and RYn9 can not be changed. Even when changed using *Pr. 178, Pr. 179, and Pr. 187*, the settings are invalid. Refer to the *Inverter Manual* for details of *Pr. 178 to Pr.189*.
- \*2 Signal names are initial values. Using *Pr. 190 to Pr. 196*, you can change output signal functions. Refer to the *Inverter Manual* for details of *Pr. 190 to Pr.196*.

## (2) Remote register

PLC Function Device No.	Address	Description	PLC Function Device No.	Address	Description
D9062	RWwn	Registers designed to read data received from the master station	D9078	RWrm	Registers designed to write data to be sent to the master station.
D9063	RWwn+1		D9079	RWrm+1	
D9064	RWwn+2		D9080	RWrm+2	
D9065	RWwn+3		D9081	RWrm+3	

("n" indicates a value determined according to the station number setting.)

## (3) Data I/O image



### REMARKS

Use the remote registers freely since they are all user areas.





## 2.3.2 I/O signal when CC-Link Ver.2 double setting is selected (Pr. 544 = 112)

The device points usable in CC-Link communication are 32 input (RX) points (12 points are available for PLC function), 32 output (RY) points (12 points are available for PLC function), 4 remote register (RWr) points and 4 remote register (RWw) points.

### (1) Remote I/O

PLC Function Device No.	Remote Output Device No.	Signal	PLC Function Device No.	Remote Input Device No.	Signal
X30	RYn0	Forward rotation command	Y30	RXn0	Forward running
X31	RYn1	Reverse rotation command	Y31	RXn1	Reverse running
X32	RYn2	High-speed operation command (terminal RH function) *1	Y32	RXn2	Running (terminal RUN function) *2
X33	RYn3	Middle-speed operation command (terminal RM function) *1	Y33	RXn3	Up to frequency (terminal SU function) *2
X34	RYn4	Low-speed operation command (terminal RL function) *1	Y34	RXn4	Overload alarm (terminal OL function) *2
X35	RYn5	Jog operation command (terminal JOG function) *1	Y35	RXn5	Instantaneous power failure (terminal IPF function) *2
X36	RYn6	Second function selection (terminal RT function) *1	Y36	RXn6	Frequency detection (terminal FU function) *2
X37	RYn7	Current input selection (terminal AU function) *1	Y37	RXn7	Error (terminal ABC1 function) *2
X38	RYn8	Selection of automatic restart after instantaneous power failure (terminal CS function) *1	Y38	RXn8	— (terminal ABC2 function) *2
X39	RYn9	Output stop	Y39	RXn9	Pr. 313 assignment function (DO0)
X3A	RYnA	Start self-holding selection (terminal STOP function) *1	Y3A	RXnA	Pr. 314 assignment function (DO1)
X3B	RYnB	Reset (terminal RES function) *1	Y3B	RXnB	Pr. 315 assignment function (DO2)
—	RYnC	Monitor command	—	RXnC	Monitoring
—	RYnD	Frequency setting command (RAM)	—	RXnD	Frequency setting completion (RAM)
—	RYnE	Frequency setting command (RAM, EEPROM)	—	RXnE	Frequency setting completion (RAM, EEPROM)
—	RYnF	Instruction code execution request	—	RXnF	Instruction code execution completion
—	RY(n+1)0 to RY(n+1)7	Reserved	—	RX(n+1)0 to RX(n+1)7	Reserved
—	RY(n+1)8	Not used (initial data process completion flag)	—	RX(n+1)8	Not used (initial data process request flag)
—	RY(n+1)9	Not used (initial data process request flag)	—	RX(n+1)9	Not used (initial data process completion flag)
—	RY(n+1)A	Error reset request flag	—	RX(n+1)A	Error status flag
—	RY(n+1)B to RY(n+1)F	Reserved	—	RX(n+1)B	Remote station ready
			—	RX(n+1)C to RX(n+1)F	Reserved

("n" indicates a value determined according to the station number setting.)

- \*1 Signal names are initial values. Using *Pr. 180 to Pr. 186, Pr. 188, and Pr. 189*, you can change input signal functions.  
Signals of the RYn0, RYn1, and RYn9 can not be changed. Even when changed using *Pr. 178, Pr. 179, and Pr. 187*, the settings are invalid.  
*Refer to the Inverter Manual for details of Pr. 178 to Pr.189.*
- \*2 Signal names are initial values. Using *Pr. 190 to Pr. 196*, you can change output signal functions.  
*Refer to the Inverter Manual for details of Pr. 190 to Pr.196.*

## (2) Remote register

PLC Function Device No.	Address	Description		PLC Function Device No.	Address	Description	
		Upper 8 Bits	Lower 8 Bits				
—	RWwn	Monitor code 2	Monitor code 1	—	RWrn	First monitor value	
—	RWwn+1	Set frequency (0.01Hz increments)		—	RWrn+1	Second monitor value	
—	RWwn+2	Link parameter expansion setting	Instruction code	—	RWrn+2	Reply code2	Reply code1
—	RWwn+3	Write data		—	RWrn+3	Read data	
D9062	RWwn+4	Registers designed to read data received from the master station		D9078	RWrn+4	Registers designed to write data to be sent to the master station.	
D9063	RWwn+5			D9079	RWrn+5		
D9064	RWwn+6			D9080	RWrn+6		
D9065	RWwn+7			D9081	RWrn+7		

("n" indicates a value determined according to the station number setting.)



### 2.3.3 I/O signal when CC-Link Ver.2 quadruple setting is selected (Pr. 544 = 114)

The device points usable in CC-Link communication are 32 input (RX) points (12 points are available for PLC function), 32 output (RY) points (12 points are available for PLC function), 8 remote register (RWr) points and 8 remote register (RWw) points.

#### (1) Remote I/O

Same as when Pr. 544 = 112 (👉 Refer to page 58)

#### (2) Remote register

PLC Function Device No.	Address	Description		PLC Function Device No.	Address	Description	
		Upper 8 Bits	Lower 8 Bits				
—	RWwn	Monitor code 2	Monitor code 1	—	RWrn	First monitor value	
—	RWwn+1	Set frequency (0.01Hz increments)		—	RWrn+1	Second monitor value	
—	RWwn+2	Link parameter expansion setting	Instruction code	—	RWrn+2	Reply code2	Reply code1
—	RWwn+3	Write data		—	RWrn+3	Read data	
—	RWwn+4	Monitor code 3		—	RWrn+4	Third monitor value	
—	RWwn+5	Monitor code 4		—	RWrn+5	Fourth monitor value	
—	RWwn+6	Monitor code 5		—	RWrn+6	Fifth monitor value	
—	RWwn+7	Monitor code 6		—	RWrn+7	Sixth monitor value	
D9062	RWwn+8	Registers designed to read data received from the master station		D9078	RWrn+8	Registers designed to write data to be sent to the master station.	
D9063	RWwn+9			D9079	RWrn+9		
D9064	RWwn+A			D9080	RWrn+A		
D9065	RWwn+B			D9081	RWrn+B		
D9066	RWwn+C			D9082	RWrn+C		
D9067	RWwn+D			D9083	RWrn+D		
D9068	RWwn+E			D9084	RWrn+E		
D9069	RWwn+F			D9085	RWrn+F		

("n" indicates a value determined according to the station number setting.)

### 2.3.4 I/O signal when CC-Link Ver.2 octuple setting is selected (Pr. 544 = 118)

The device points usable in CC-Link communication are 32 input (RX) points (12 points are available for PLC function), 32 output (RY) points (12 points are available for PLC function), 16 remote register (RW<sub>r</sub>) points and 16 remote register (RW<sub>w</sub>) points.

#### (1) Remote I/O

Same as when Pr. 544 = 112 (Refer to page 58)

#### (2) Remote register

PLC Function Device No.	Address	Description		PLC Function Device No.	Address	Description	
		Upper 8 Bits	Lower 8 Bits				
—	RW <sub>w</sub> n	Monitor code 2	Monitor code 1	—	RW <sub>r</sub> n	First monitor value	
—	RW <sub>w</sub> n+1	Set frequency (0.01Hz increments)		—	RW <sub>r</sub> n+1	Second monitor value	
—	RW <sub>w</sub> n+2	Link parameter expansion setting	Instruction code	—	RW <sub>r</sub> n+2	Reply code2	Reply code1
—	RW <sub>w</sub> n+3	Write data		—	RW <sub>r</sub> n+3	Read data	
—	RW <sub>w</sub> n+4	Monitor code 3		—	RW <sub>r</sub> n+4	Third monitor value	
—	RW <sub>w</sub> n+5	Monitor code 4		—	RW <sub>r</sub> n+5	Fourth monitor value	
—	RW <sub>w</sub> n+6	Monitor code 5		—	RW <sub>r</sub> n+6	Fifth monitor value	
—	RW <sub>w</sub> n+7	Monitor code 6		—	RW <sub>r</sub> n+7	Sixth monitor value	
—	RW <sub>w</sub> n+8	Faults history No.	H00	—	RW <sub>r</sub> n+8	Faults history No.	Faults history data
—	RW <sub>w</sub> n+9	PID set point (0.01% increments) *1		—	RW <sub>r</sub> n+9	Faults history (output frequency)	
—	RW <sub>w</sub> n+A	PID measured value (0.01% increments) *2		—	RW <sub>r</sub> n+A	Faults history (output current)	
—	RW <sub>w</sub> n+B	PID deviation (0.01% increments) *3		—	RW <sub>r</sub> n+B	Faults history (output voltage)	
—	RW <sub>w</sub> n+C	Reserved		—	RW <sub>r</sub> n+C	Faults history (energization time)	
—	RW <sub>w</sub> n+D	H00 (Free)		—	RW <sub>r</sub> n+D	H00 (Free)	
—	RW <sub>w</sub> n+E			—	RW <sub>r</sub> n+E		
—	RW <sub>w</sub> n+F			—	RW <sub>r</sub> n+F		

\*1 When Pr. 128 = "40, 41, 60, 61, 140, 141", they are valid.

\*2 When Pr. 128 = "60, 61", they are valid.

\*3 When Pr. 128 = "50, 51", they are valid.



PLC Function Device No.	Address	Description		PLC Function Device No.	Address	Description
		Upper 8 Bits	Lower 8 Bits			
D9062	RWwn+10	Registers designed to read data received from the master station		D9078	RWrn+10	Registers designed to write data to be sent to the master station
D9063	RWwn+11					
D9064	RWwn+12					
D9065	RWwn+13					
D9066	RWwn+14					
D9067	RWwn+15					
D9068	RWwn+16					
D9069	RWwn+17					
D9070	RWwn+18					
D9071	RWwn+19					
D9072	RWwn+1A					
D9073	RWwn+1B					
D9074	RWwn+1C					
D9075	RWwn+1D					
D9076	RWwn+1E	D9085	RWrn+17			
D9077	RWwn+1F	D9086	RWrn+18			
		D9087	RWrn+19			
		D9088	RWrn+1A			
		D9089	RWrn+1B			
		D9090	RWrn+1C			
		D9091	RWrn+1D			
		D9092	RWrn+1E			
		D9093	RWrn+1F			

("n" indicates a value determined according to the station number setting.)



## 2.4 Buffer memory

### 2.4.1 Remote output signals (Master module to inverter(FR-A7NC))

- Input states to the remote device station are stored.
- Two words are used for each station.  
(Do not use address 16n (n = 2(X - 1) + 1, X = station No.))

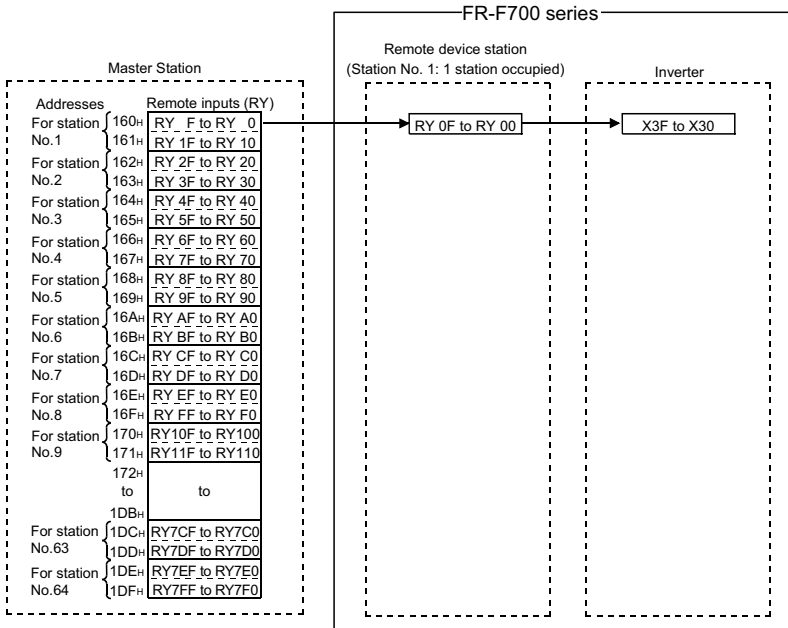

Correspondences between Master Station Buffer Memory Addresses and Station Numbers

Station No.	Buffer Memory Address	Station No.	Buffer Memory Address	Station No.	Buffer Memory Address	Station No.	Buffer Memory Address
1	160H	17	180H	33	1A0H	49	1C0H
2	162H	18	182H	34	1A2H	50	1C2H
3	164H	19	184H	35	1A4H	51	1C4H
4	166H	20	186H	36	1A6H	52	1C6H
5	168H	21	188H	37	1A8H	53	1C8H
6	16AH	22	18AH	38	1AAH	54	1CAH
7	16CH	23	18CH	39	1ACH	55	1CCH
8	16EH	24	18EH	40	1AEH	56	1CEH
9	170H	25	190H	41	1B0H	57	1D0H
10	172H	26	192H	42	1B2H	58	1D2H
11	174H	27	194H	43	1B4H	59	1D4H
12	176H	28	196H	44	1B6H	60	1D6H
13	178H	29	198H	45	1B8H	61	1D8H
14	17AH	30	19AH	46	1BAH	62	1DAH
15	17CH	31	19CH	47	1BCH	63	1DCH
16	17EH	32	19EH	48	1BEH	64	1DEH



## 2.4.2 Remote input signals Pr.544=100 (Inverter(FR-A7NC) to master module)

- Input states from the remote device station are stored.
- Two words are used for each station.

(Do not use address En (n = 2(X - 1) + 1, X = station No.))

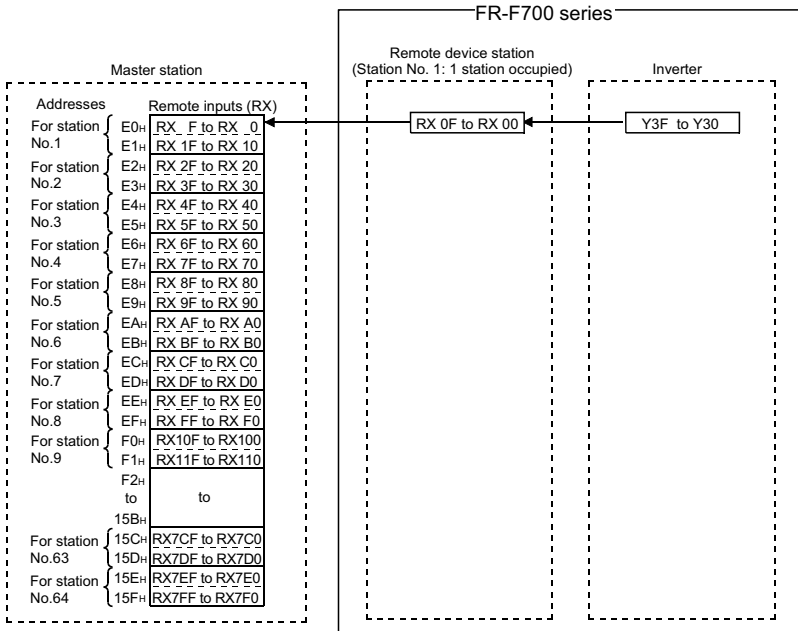

Correspondences between Master Station Buffer Memory Addresses and Station Numbers

Station No.	Buffer Memory Address	Station No.	Buffer Memory Address	Station No.	Buffer Memory Address	Station No.	Buffer Memory Address
1	E0H	17	100H	33	120H	49	140H
2	E2H	18	102H	34	122H	50	142H
3	E4H	19	104H	35	124H	51	144H
4	E6H	20	106H	36	126H	52	146H
5	E8H	21	108H	37	128H	53	148H
6	EAH	22	10AH	38	12AH	54	14AH
7	ECH	23	10CH	39	12CH	55	14CH
8	EEH	24	10EH	40	12EH	56	14EH
9	F0H	25	110H	41	130H	57	150H
10	F2H	26	112H	42	132H	58	152H
11	F4H	27	114H	43	134H	59	154H
12	F6H	28	116H	44	136H	60	156H
13	F8H	29	118H	45	138H	61	158H
14	FAH	30	11AH	46	13AH	62	15AH
15	FCH	31	11CH	47	13CH	63	15CH
16	FEH	32	11EH	48	13EH	64	15EH

### 2.4.3 Remote registers Pr.544=100 (Master module to inverter(FR-A7NC))

- Data to be sent to the remote registers (RWW) of the remote device station are stored.
- Four words are used for each station.

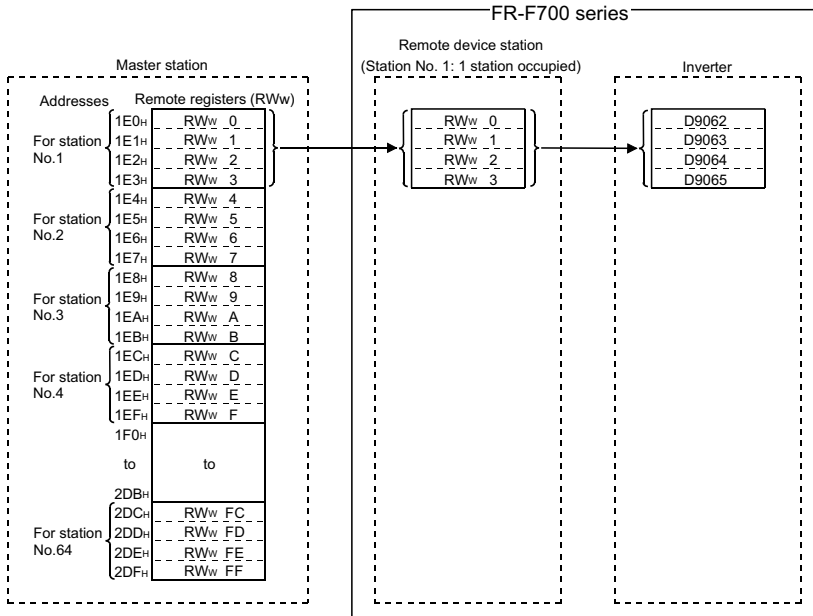

Correspondences between Master Station Buffer Memory Addresses and Station Numbers

Station No.	Buffer Memory Address	Station No.	Buffer Memory Address	Station No.	Buffer Memory Address	Station No.	Buffer Memory Address
1	1E0H to 1E3H	17	220H to 223H	33	260H to 263H	49	2A0H to 2A3H
2	1E4H to 1E7H	18	224H to 227H	34	264H to 267H	50	2A4H to 2A7H
3	1E8H to 1EBH	19	228H to 22BH	35	268H to 26BH	51	2A8H to 2ABH
4	1ECH to 1EFH	20	22CH to 22FH	36	26CH to 26FH	52	2ACH to 2AFH
5	1F0H to 1F3H	21	230H to 233H	37	270H to 273H	53	2B0H to 2B3H
6	1F4H to 1F7H	22	234H to 237H	38	274H to 277H	54	2B4H to 2B7H
7	1F8H to 1FBH	23	238H to 23BH	39	278H to 27BH	55	2B8H to 2BBH
8	1FCH to 1FFH	24	23CH to 23FH	40	27CH to 27FH	56	2BCH to 2BFH
9	200H to 203H	25	240H to 243H	41	280H to 283H	57	2C0H to 2C3H
10	204H to 207H	26	244H to 247H	42	284H to 287H	58	2C4H to 2C7H
11	208H to 20BH	27	248H to 24BH	43	288H to 28BH	59	2C8H to 2CBH
12	20CH to 20FH	28	24CH to 24FH	44	28CH to 28FH	60	2CCH to 2CFH
13	210H to 213H	29	250H to 253H	45	290H to 293H	61	2D0H to 2D3H
14	214H to 217H	30	254H to 257H	46	294H to 297H	62	2D4H to 2D7H
15	218H to 21BH	31	258H to 25BH	47	298H to 29BH	63	2D8H to 2DBH
16	21CH to 21FH	32	25CH to 25FH	48	29CH to 29FH	64	2DCH to 2DFH





## 2.4.4 Remote registers Pr.544=100 (Inverter(FR-A7NC) to master module)

- Data sent from the remote registers (RWR) of the remote device station are stored.
- Four words are used for each station.

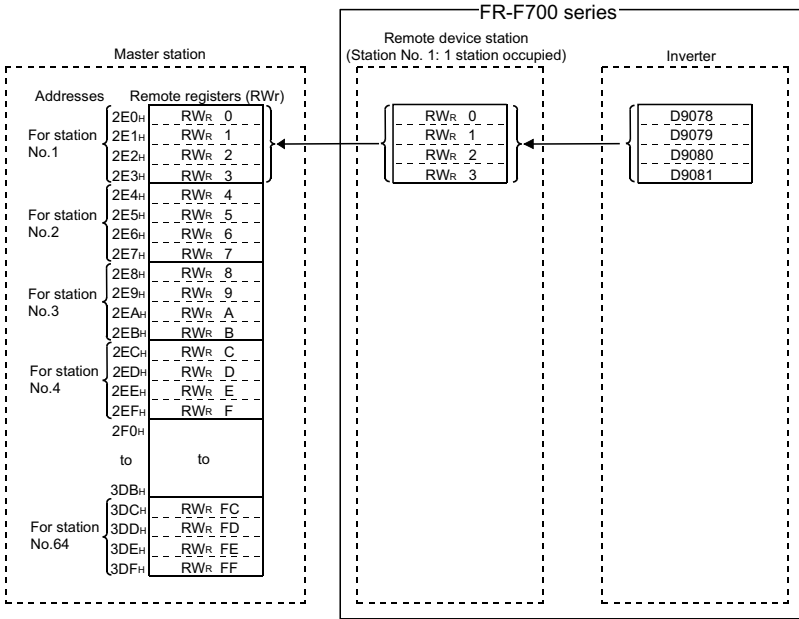

Correspondences between Master Station Buffer Memory Addresses and Station Numbers

Station No.	Buffer Memory Address	Station No.	Buffer Memory Address	Station No.	Buffer Memory Address	Station No.	Buffer Memory Address
1	2E0H to 2E3H	17	320H to 323H	33	360H to 363H	49	3A0H to 3A3H
2	2E4H to 2E7H	18	324H to 327H	34	364H to 367H	50	3A4H to 3A7H
3	2E8H to 2EBH	19	328H to 32BH	35	368H to 36BH	51	3A8H to 3ABH
4	2ECH to 2EFH	20	32CH to 32FH	36	36CH to 36FH	52	3ACH to 3AFH
5	2F0H to 2F3H	21	330H to 333H	37	370H to 373H	53	3B0H to 3B3H
6	2F4H to 2F7H	22	334H to 337H	38	374H to 377H	54	3B4H to 3B7H
7	2F8H to 2FBH	23	338H to 33BH	39	378H to 37BH	55	3B8H to 3BBH
8	2FCH to 2FFH	24	33CH to 33FH	40	37CH to 37FH	56	3BCH to 3BFH
9	300H to 303H	25	340H to 343H	41	380H to 383H	57	3C0H to 3C3H
10	304H to 307H	26	344H to 347H	42	384H to 387H	58	3C4H to 3C7H
11	308H to 30BH	27	348H to 34BH	43	388H to 38BH	59	3C8H to 3CBH
12	30CH to 30FH	28	34CH to 34FH	44	38CH to 38FH	60	3CCH to 3CFH
13	310H to 313H	29	350H to 353H	45	390H to 393H	61	3D0H to 3D3H
14	314H to 317H	30	354H to 357H	46	394H to 397H	62	3D4H to 3D7H
15	318H to 31BH	31	358H to 35BH	47	398H to 39BH	63	3D8H to 3DBH
16	31CH to 31FH	32	35CH to 35FH	48	39CH to 39FH	64	3DCH to 3DFH

# 3. SEQUENCE PROGRAMMING

3.1	Overview .....	68
3.2	RUN and STOP operation processings .....	70
3.3	Program makeup .....	70
3.4	Programming languages .....	71
3.5	Operation processing method of PLC function....	74
3.6	I/O processing method .....	75
3.7	Scan time .....	77
3.8	Numerical values usable in sequence program ...	78
3.9	Description of devices .....	82
3.10	Counters C .....	90
3.11	Data registers D .....	93
3.12	Special relays, special registers .....	94
3.13	Function list .....	96
3.14	How to RUN/STOP the built-in PLC function from outside (remote RUN/STOP) .....	97
3.15	Watchdog timer (operation clog up monitor timer) .....	99
3.16	Self-diagnostic function .....	100
3.17	Keyword registration .....	102
3.18	Setting of output (Y) status at switching from STOP status to RUN status.....	103
3.19	Instruction format.....	104
3.20	Bit device processing method .....	106
3.21	Handling of numerical value .....	110
3.22	Operation error .....	111
3.23	Instructions list.....	112
3.24	Description of the instructions .....	121
3.25	Sequence instructions .....	122
3.26	Basic instructions (16-bit) .....	148
3.27	Basic instructions (32-bit) .....	163
3.28	Application instructions .....	178
3.29	Display command.....	193

Chapter 1

Chapter 2

Chapter 3

Chapter 4



## 3.1 Overview

---

### 3.1.1 Outline of operation processings

This section outlines processings performed from when the inverter is powered on until a sequence program is executed.

The built-in PLC function processings are roughly classified into the following three types.

(1) Initial processing

Pre-processing for executing sequence operation. This processing is executed only once when power is switched on or a reset is performed.

- (a) The inputs/outputs are reset and initialized.
- (b) The data memories are initialized (the bit devices are turned off and the word devices are cleared to 0).
- (c) Self-diagnostic checks are made on the built-in PLC function parameter setting, operation circuit, etc.

<b>REMARKS</b>
----------------

The built-in PLC function parameters can be confirmed from GX Developer. (Refer to the GX Developer Operating Manual.)
--

(2) Sequence program operation processing

The sequence program written to the built-in PLC function is executed from step 0 to an END instruction.

(3) END processing

Post-processing for terminating one sequence program operation processing and return the sequence program execution to step 0.

- (a) Self-diagnostic checks are performed.
- (b) The present values of the timers are updated and their contacts are turned on/off, and the present values of the counters are updated and their contacts are turned on.

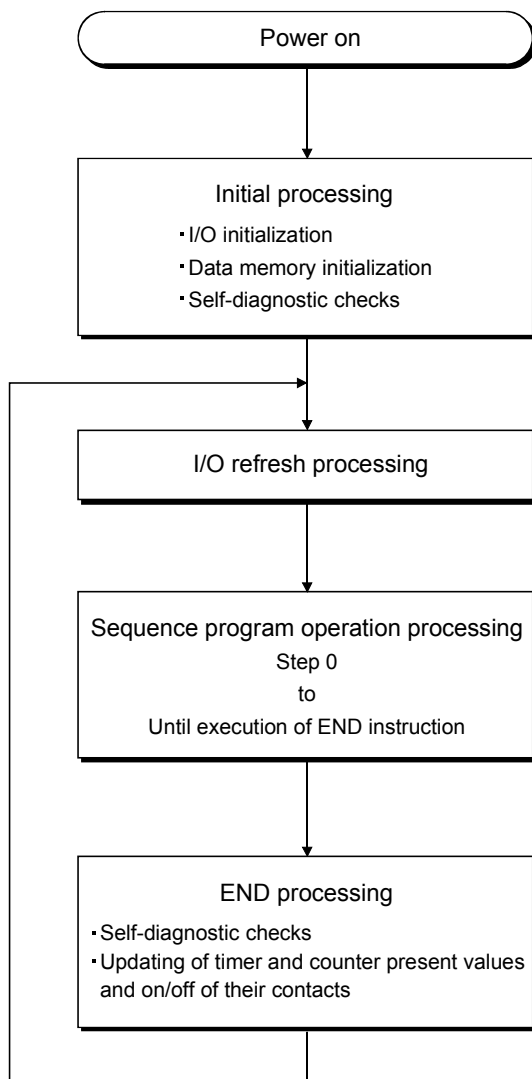

Fig 3.1 Operation Processings of Built-in PLC function



## 3.2 RUN and STOP operation processings

---

The built-in PLC function has two different operation statuses: RUN status and STOP status.

This section explains the operation processings of the built-in PLC function in each operating status.

(1) Operation processing in RUN status

A RUN status indicates that a sequence program is repeating its operation in order of step 0 to END (FEND) instruction while the SQ signal is ON. (P.RUN is on)

When entering the RUN status, the function outputs the output status saved at STOP according to the "STOP to RUN-time output mode setting" (*refer to page 103*).

(2) Operation processing in STOP status

A STOP status indicates that a sequence program is stopping its operation while the SQ signal is OFF or after remote STOP is commanded. (P.RUN is off)

When entering the STOP status, the function saves the output status and turns off all outputs. The contents of the data memories other than the outputs (Y) are maintained.

### POINT

In either the RUN or STOP status, the built-in PLC function is performing I/O refresh processings. In the STOP status, therefore, I/O monitoring and test operation can be performed from the peripheral device.

## 3.3 Program makeup

---

(1) Program classification

The program that can be used by the built-in PLC function is a main sequence program only. Microcomputer, interrupt and SFC programs cannot be used.

(2) Program capacity

A program capacity indicates the capacity of the program storage memory, and it is 4k steps. Set the program capacity in the built-in PLC function parameter.

## 3.4 Programming languages

The built-in PLC function has two different programming methods: one that uses ladders and the other that uses dedicated instructions.

- Programming that uses ladders is performed in the relay symbolic language. \*1
- Programming that uses dedicated instructions is performed in the logic symbolic language. \*2

Whether the relay symbolic language or logic symbolic language is used, the same program is created.

### REMARKS

- \*1. When using GX Developer for programming, perform programming in the "ladder mode".
- \*2. When using GX Developer for programming, perform programming in the "list mode".

### 3.4.1 Relay symbolic language (ladder mode)

The relay symbolic language is based on the concept of a relay control circuit.

You can perform programming in the representation close to the sequence circuit of relay control.

#### (1) Ladder block

A ladder block is the minimum unit for performing sequence program operation. It starts with the left hand side vertical bus and ends with the right hand side vertical bus.

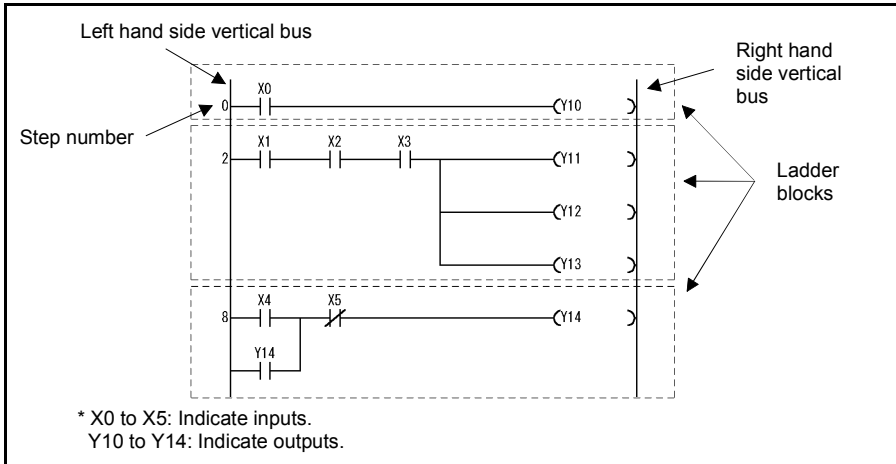

Fig 3.2 Ladder Blocks



(2) Sequence program operation method

Sequence program operation repeats execution from a ladder block at step 0 to an END instruction.

In a single ladder block, operation is performed from the left hand side vertical bus to the right, and from the top to the bottom.

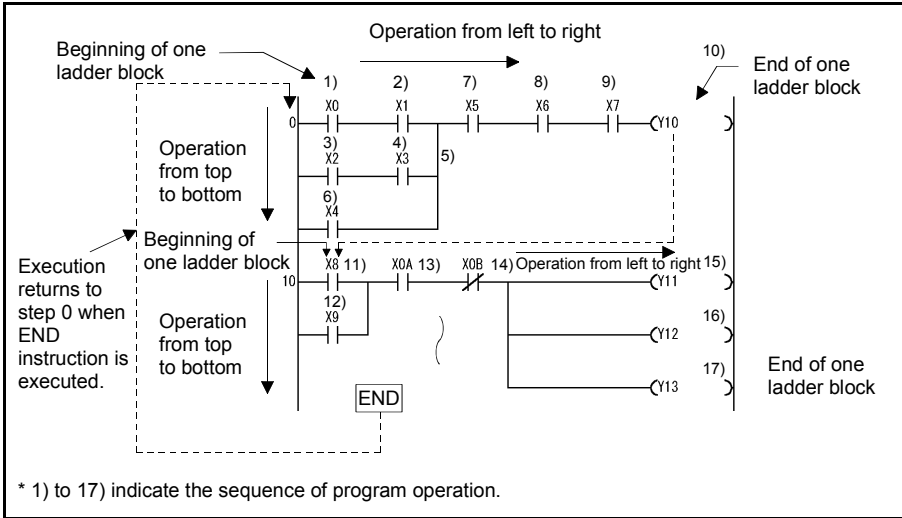

Fig 3.3 Operation Processing Sequence

### 3.4.2 Logic symbolic language (list mode)

The logic symbolic language uses dedicated instructions for programming contacts, coils, etc. instead of their symbols used by the relay symbolic language.

(1) Program operation method

Sequence program operation is executed from an instruction at step 0 to an END instruction in due order. When the END instruction is executed, operation is executed from the instruction at step 0 again.

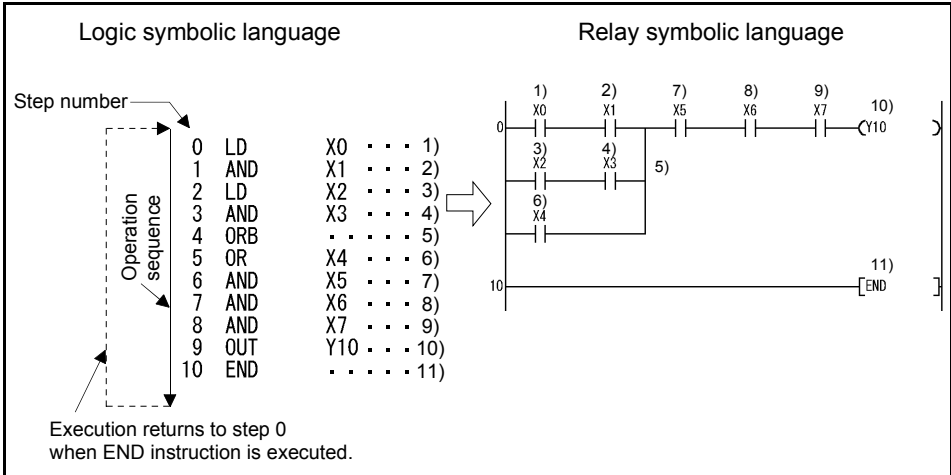

Fig 3.4 Operation Processing Sequence



### 3.5 Operation processing method of PLC function

The operation processing method is the repeated operation of a stored program.

(1) Stored program system

- 1) In a stored program system, a sequence program to be operated is stored in the internal memory beforehand.
- 2) When sequence program operation is executed, the sequence program stored in the built-in PLC function is read to the CPU instruction by instruction to execute the operation, and the corresponding devices are controlled according to the results.

(2) Repeated operation system

In a repeated operation system, a sequence of operations is repeated. The built-in PLC function repeats the following processings.

- 1) The built-in PLC function executes the sequence program stored in the internal memory from step 0 in due order.
- 2) When the END instruction is executed, internal processings, such as timer/counter present value updating and self-diagnostic checks, are performed, and the execution returns to step 0 of the sequence program again.

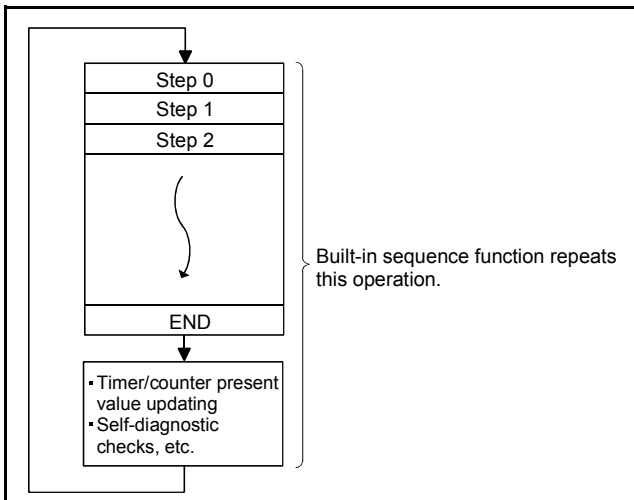

Fig 3.5 Operation Processing Method of Built-in PLC Function

**REMARKS**

A processing from step 0 to next step 0 or from END to next END is called one scan. Therefore, one scan is the sum of the processing time of a user-created program (step 0 to END) and the internal processing time of the built-in PLC function.

### 3.6 I/O processing method

The control system is a refresh system.

#### 3.6.1 What is refresh system?

In the refresh system, control input terminal changes are batch-imported into the input data memory of the CPU before execution of each scan, and the data of this input data memory are used as the input data for operation execution.

Each program operation result of the output (Y) is output to the output data memory, and after the END instruction is executed, the contents of the output data memory are batch-output from the control output terminal.

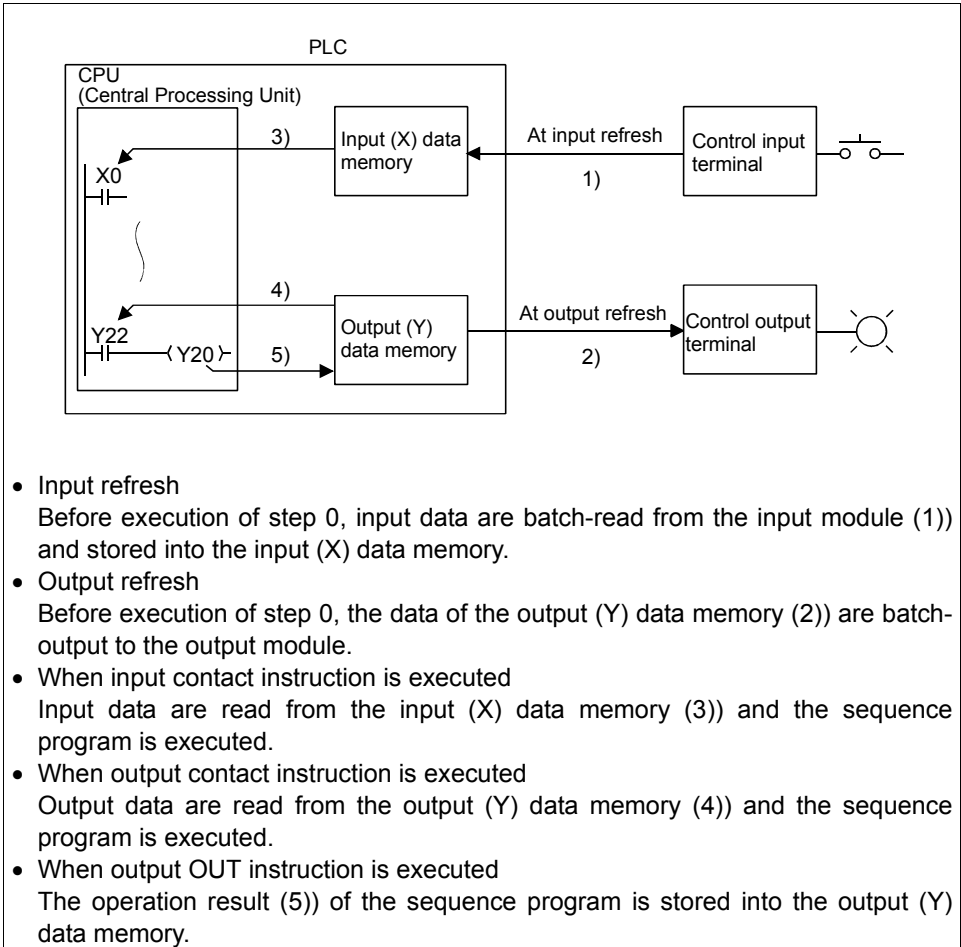

Fig 3.6 I/O Data Flows in Refresh System



### 3.6.2 Response delay in refresh system

This section describes a delay of an output change in response to an input change. An output change in response to an input change has a delay of up to two scans as shown in Fig. 3.7.

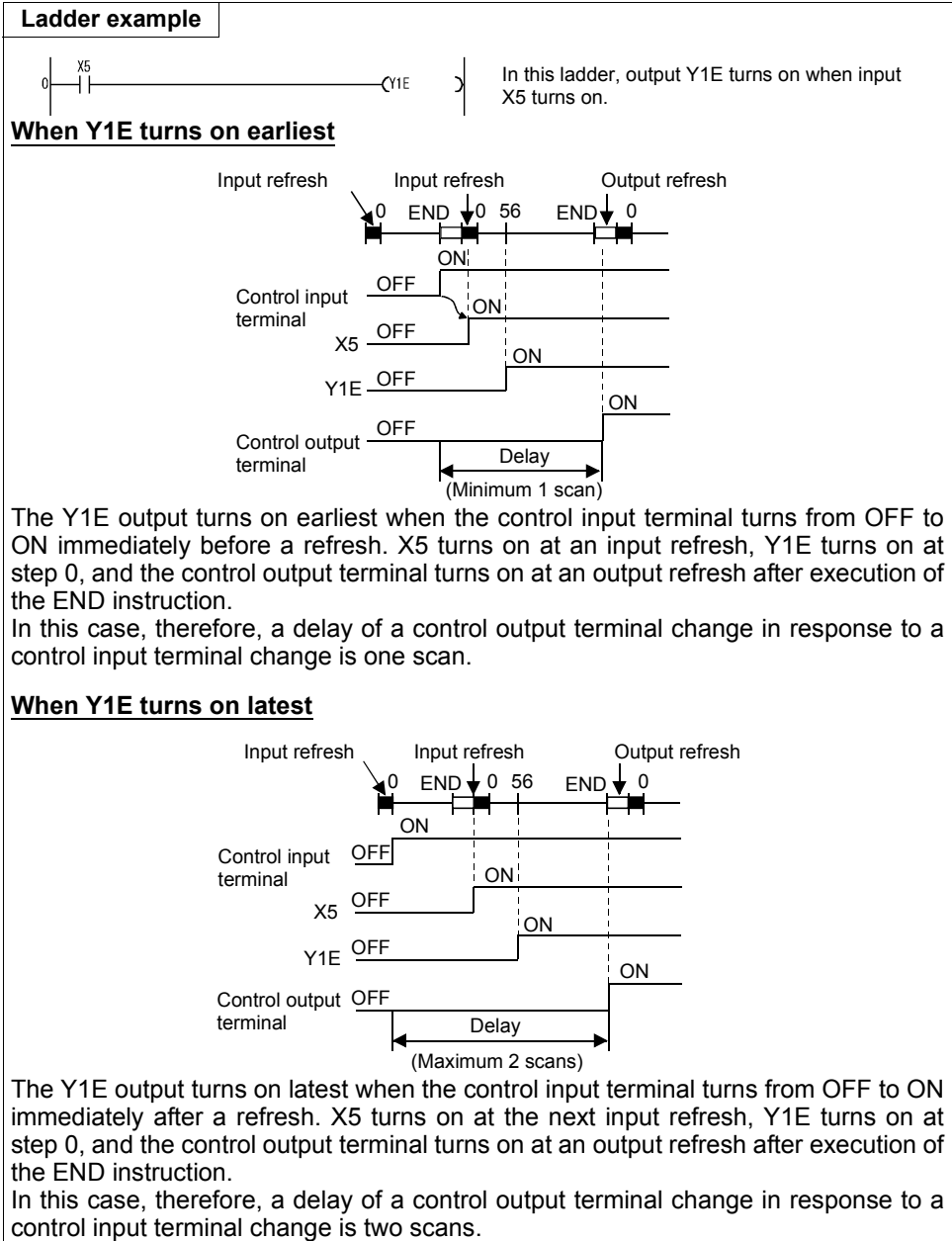

Fig 3.7 Output Y Change in Response to Input X Change

### 3.7 Scan time

(1) Scan time

A scan time is a time from when sequence program operation is executed from step 0 until step 0 is executed again.

The scan time of each scan is not equal, and changes depending on whether the used instructions are executed or not.

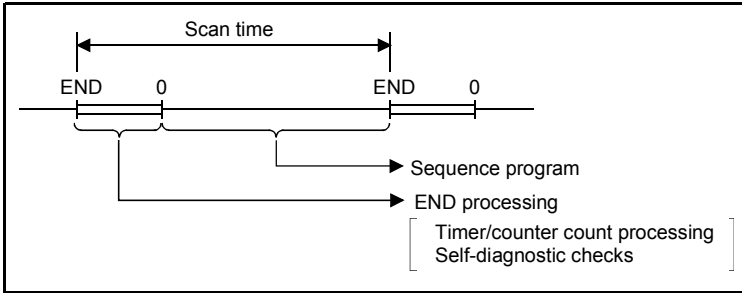

Fig 3.8 Scan Time

(2) Scan time confirmation

(a) The scan time from the END instruction to the next END instruction is timed in the PLC, and stored into the special registers D9017 to D9019 in units of 10ms.

1) Data stored into special registers D9017 to D9019

- D9017 ..... Minimum value of scan time
- D9018 ..... Present value of scan time
- D9019 ..... Maximum value of scan time

2) Scan time accuracy

The accuracy of the scan time observed in the PLC is  $\pm 10$ ms.

For example, when the D9018 data is 5, the actual scan time is 40ms to 60ms.



### 3.8 Numerical values usable in sequence program

The built-in PLC function represents numerical values, alphabets and other data in two statuses: 0 (OFF) and 1 (ON).

The data represented by these 0s and 1s are called BIN (binary code).

The built-in PLC function can also use HEX (hexadecimal code) that represents BIN data in blocks of four bits.

Table 3.1 indicates the numerical representations of BIN, HEX and decimal code.

Table 3.1 Numerical Representations of BIN, HEX and Decimal Code

<b>DEC</b> <b>(Decimal Code)</b>	<b>HEX</b> <b>(Hexadecimal Code)</b>	<b>BIN</b> <b>(Binary Code)</b>
0	0	0
1	1	1
2	2	10
3	3	11
•	•	•
•	•	•
•	•	•
•	•	•
•	•	•
•	•	•
9	9	1001
10	A	1010
11	B	1011
12	C	1100
13	D	1101
14	E	1110
15	F	1111
16	10	10000
17	11	10001
•	•	•
•	•	•
•	•	•
•	•	•
•	•	•
•	•	•
47	2F	101111



### 3.8.1 BIN (Binary Code)

(1) Binary code

BIN is a numerical value represented by 0s (OFF) and 1s (ON).

In the decimal code, a number is incremented from 0 to 9, and at this point, a carry occurs and the number is incremented to 10.

In BIN, 0, 1 are followed by a carry, and the number is incremented to 10 (2 in decimal).

Table 3.2 indicates the numerical representations of BIN and decimal code.

Table 3.2 Differences between Numerical Representations of BIN and Decimal Code

DEC (Decimal Code)	BIN (Binary Code)
0	0000
1	0001
2	0010
3	0011
4	0100
5	0101
6	0110
7	0111
8	1000
9	1001
10	1010
11	1011

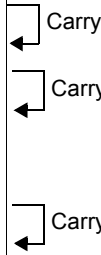



(2) Numerical representation of BIN

1) Each register (e.g. data register) of the built-in PLC function consist of 16 bits.

Each bit of the register is assigned a  $2^n$  value.

However, the most significant bit is used to judge whether the value is positive or negative.

- Most significant bit is 0 ..... Positive
- Most significant bit is 1 ..... Negative

The numerical representation of each register of the built-in PLC function is shown in Fig. 3.9.

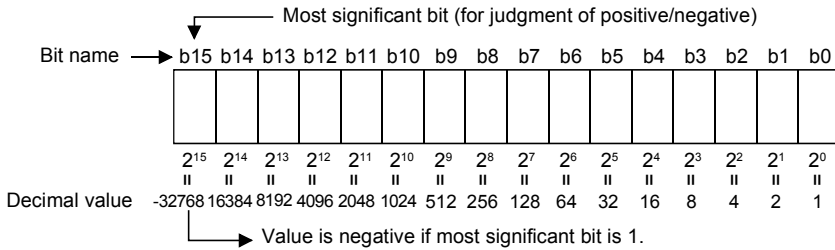

Fig 3.9 Numerical Representation of Each Register of Built-in PLC Function

2) Numerical data usable with the built-in PLC function

In the numerical representation shown in Fig. 3.9, values can be represented in the range -32768 to 32767.

Therefore, each register of the built-in PLC function can store any value between -32768 and 32767.

### 3.8.2 HEX (HEX Decimal)

(1) HEX

HEX represents four bits of BIN data as one digit.

Using four bits in BIN, you can represent 16 values from 0 to 15.

Since HEX represents any of 0 to 15 in a single digit, 9 is followed by alphabets A (instead of 10), B (11)..., and F (15) is followed by a carry.

*Refer to page 78 for the correspondences between BIN, HEX and decimal code.*

(2) Numerical representation of HEX

Each register (e.g. data register) of the built-in PLC function consist of 16 bits.

Therefore, the value that can be stored into each register is represented as any of 0 to HFFFF in HEX.





## 3.9 Description of devices

### 3.9.1 Device list

The following table indicates the device names usable with the built-in PLC function and their ranges of use.

Table 3.3 Device List

Input (X)		64 (X0 to X3F) <12 points installed>
Output (Y)		64 (Y0 to Y3F) <7 points installed>
Internal relay (M)		64 (M0 to M63)
Latch relay (L)		None (Can be set with built-in PLC function parameters but will not latch)
Step relay (S)		None (Can be set with built-in PLC function parameters but will operate as M)
Link relay (B)		None
Timer (T)	Points	16(T0 to T15)
	Specifications	100ms timer: Set time 0.1 to 3276.7s 10ms timer: Set time 0.01 to 327.67s 100ms retentive timer: Set time 0.1 to 3276.7s
Counter (C)	Points	16(C0 to C15)
	Specifications	Normal counter: Setting range 1 to 32767 Interrupt program counter: None
Data device (D)		160(D0 to D159)
Link register (W)		None
Annunciator (F)		None
File register (R)		None
Accumulator (A)		None
Index register (Z, V)		None
Pointer (P)		None
Interrupt pointer (I)		None
Special relay (M)		256 (M9000 to M9255) with function limit
Special register (D)		256 (D9000 to D9255) with function limit

### 3.9.2 Inputs, outputs X, Y

Inputs and outputs are devices designed to transfer data between the inverter and external devices.

Inputs provide ON/OFF data given to the corresponding control input terminals from outside the inverter. In a program, they are used as contacts (normally open, normally closed contacts) and the source data of basic instructions. Outputs are used when the operation results of a program are output from the control output terminals to outside the inverter.

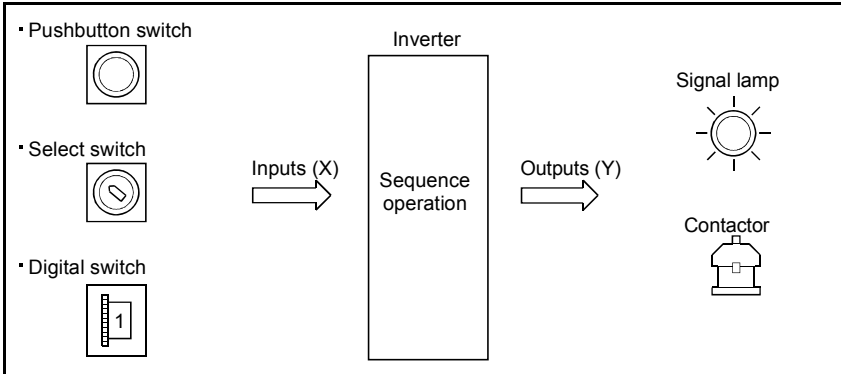

Fig 3.10 Inputs (X), Outputs (Y)



**(1) Inputs X**

- (a) Inputs are designed to give commands and data from external devices, such as pushbuttons, select switches, limit switches and digital switches, to the inverter (built-in PLC function).
- (b) On the assumption that the PLC function contains a virtual relay Xn for one input point, the normally open (N/O) or normally closed (N/C) contact of that Xn is used in the program.

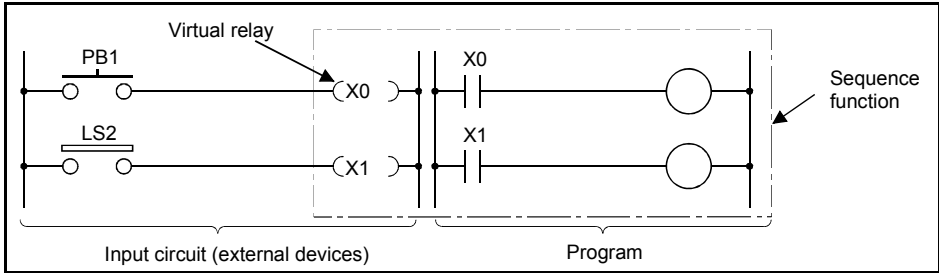

Fig 3.11 Concept of Inputs (X)

- (c) There are no restrictions on the number of N/O and N/C contacts of Xn used in the program.

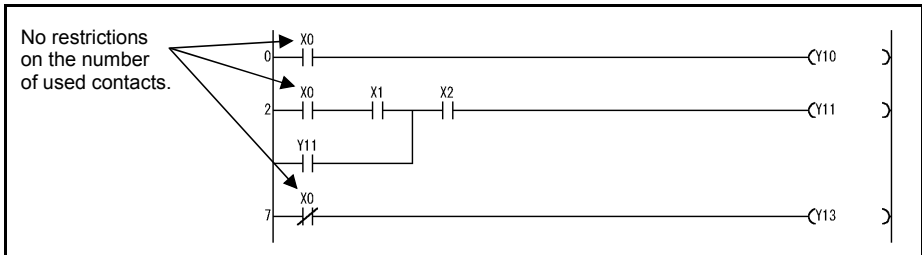

Fig 3.12 Use of Contacts in Input (X) Program

When no external devices are connected to the control input terminals, "X" can be used as the internal relay "M".

## (2) Outputs Y

- Outputs are designed to output the control results of a program to outside the inverter (signal lamps, digital indicators, magnetic switches (contactors), solenoids, etc.).
- An output can be exported to outside the inverter as equivalent to one N/O contact.
- There are no restrictions on the number of N/O and N/C contacts of output Y<sub>n</sub> used in the program, if they are used within the program capacity range.

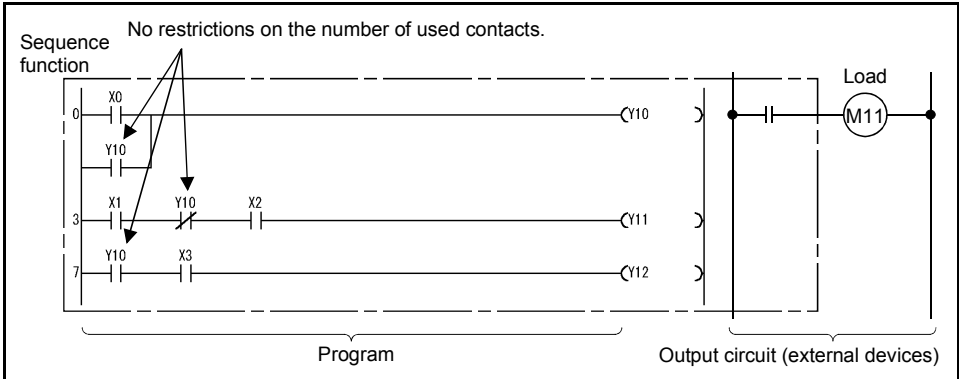

Fig 3.13 Concept of Outputs (Y)

When no external devices are connected to the control output terminals, "Y" can be used as the internal relay "M".



### 3.9.3 Internal relays M

Internal relays are auxiliary relays that are used in the PLC function and cannot latch data (backup for power failure).

All internal relays are turned off when:

- Power is switched from off to on; or
- Reset is performed.

There are no restrictions on the number of contacts (N/O and N/C contacts) used in the program.

Use outputs (Y) when outputting the operation results of the sequence program to outside the inverter.

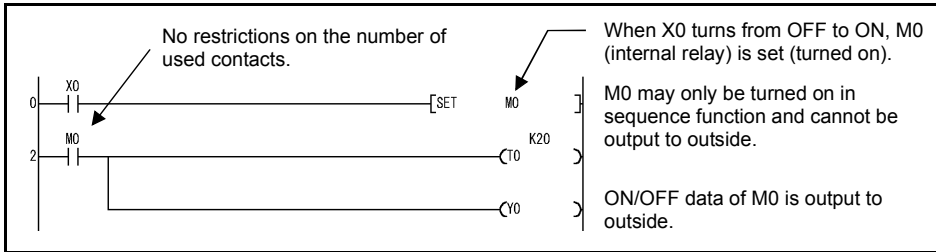

Fig 3.14 Internal Relay

### 3.9.4 Timers T

The timers of the PLC function are count up timers.

The count up timer starts timing the present value when its coil turns on, and the contact of that timer turns on when the present value reaches the setting (time-out).

### 3.9.5 100ms, 10ms and 100ms retentive timers

#### (1) 100ms and 10ms timers

The timer starts timing the present value when its coil turns on, and the present value is reset to 0 and the contact turns off when the coil turns off.

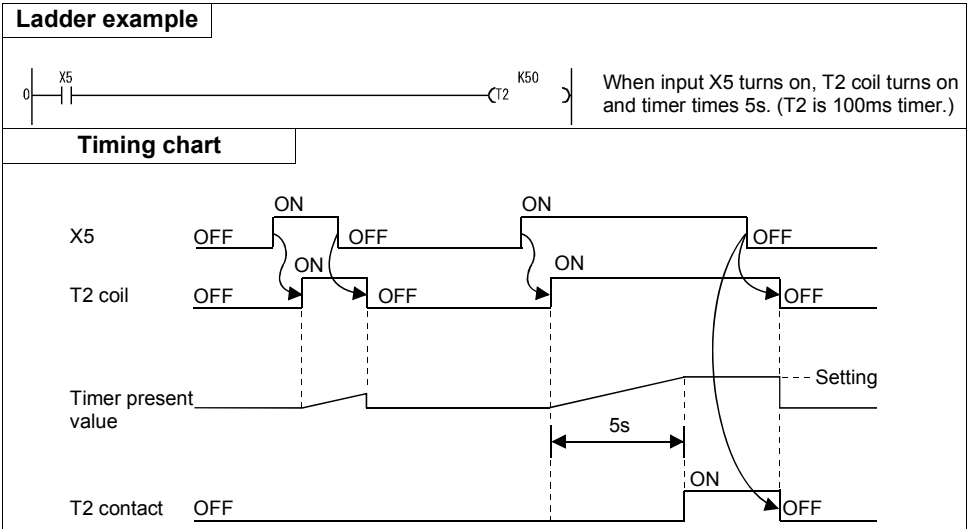

Fig 3.15 Timing Chart

#### REMARKS

100ms, 10ms and 100ms retentive timers can be changed using the built-in PLC function parameter. (The default is a 100ms timer.)



## (2) 100ms retentive timers

1) A 100ms retentive timer is designed to time the ON period of the timer coil.

When its coil turns on, the timer starts timing the present value and maintains the present value and contact ON/OFF state if the coil turns off.

When the coil turns on again, the timer resumes timing from the maintained present value.

2) Use the RST T□ instruction to clear the present value and turn off the contact.

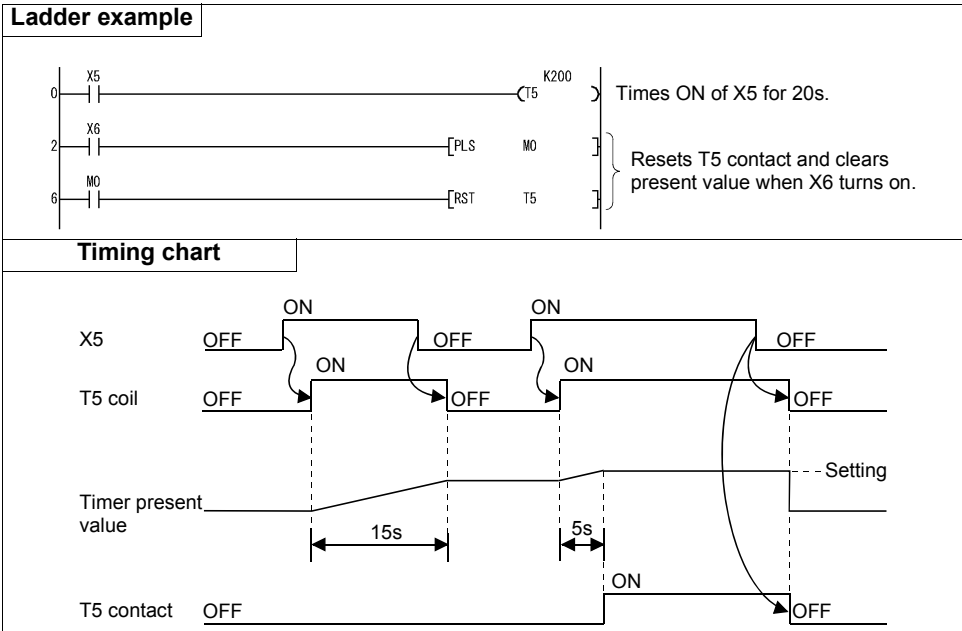

Fig 3.16 Timing Chart

### 3.9.6 Timer processing method and accuracy

#### (1) Timer processing method

The coil of the timer is turned on/off at execution of the OUT T□ instruction, and the timer's present value is updated and its contact turned on/off at execution of the END instruction.

1) When the coil of the timer turns on, the present value of that timer is updated after execution of the END instruction, and when the timer times out, its contact turns on.

(a) When the coil of the 10ms or 100ms timer turns off, the present value of that timer is reset to 0 and the contact is also turned off after execution of the END instruction.

(b) If its coil turns off, the 100ms retentive timer maintains the prevent value and contact ON/OFF state.

2) When the timer is reset by the RST instruction, the present value of the timer is reset to 0 and the contact turns off too at execution of the RST T□ instruction.

#### POINT

If the timer setting is "0", the setting becomes infinite and the timer does not time out.



(2) Present value update timing and accuracy in refresh system

- 1) The timer accuracy is +2 scan times independently of the used timer and scan time.
- 2) The following shows the present value update timing and accuracy when the 10ms timer is used in a program where the scan time is 10ms or more.

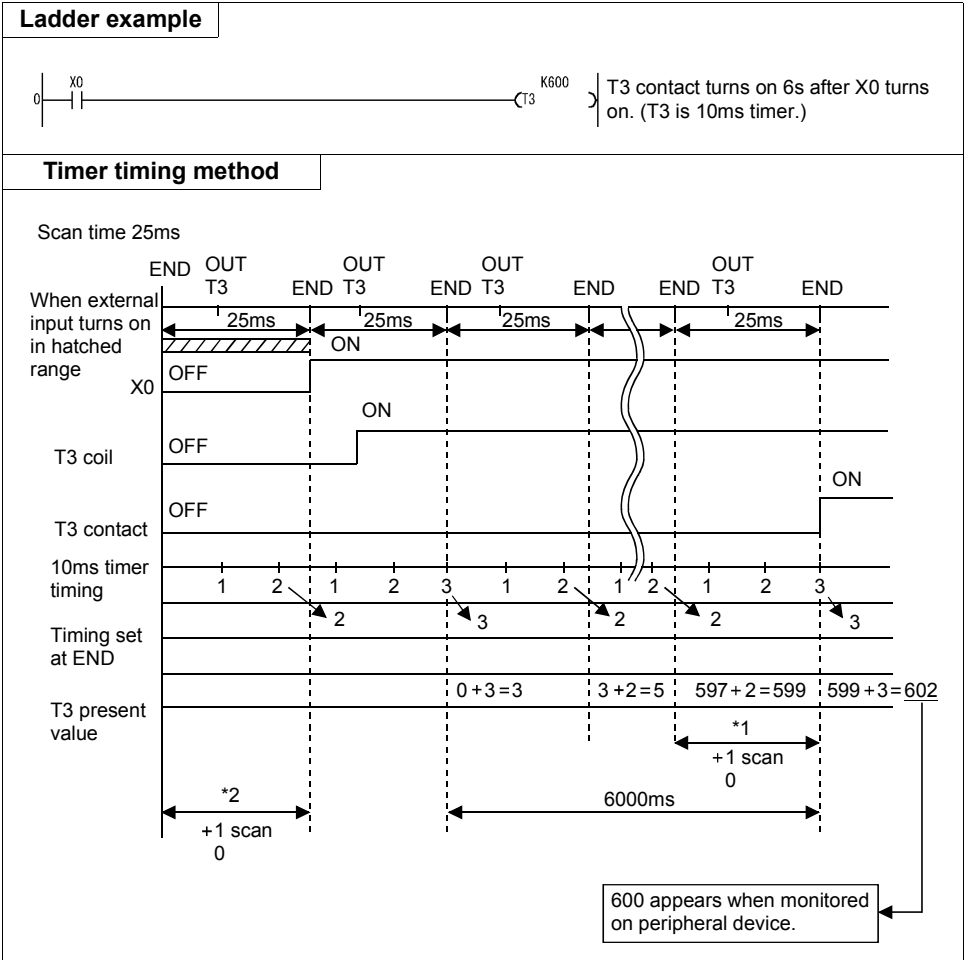

Fig 3.17 Timer Timing Method

In Fig. 3.17, the time-out period of the 10ms timer T3 has the following errors.

- \*1..... 10ms timer error (+1 scan time)
- \*2..... Error produced by timer's input condition ON timing and OUT T□ instruction's program position (+1 scan time)

The accuracy is +2 scan time (+0.05s in Fig. 3.17)

- 3) When the timer times out, its contact remains on until END even if the coil turns off, and turns off at execution of the END instruction.





## 3.10 Counters C

The counters of the built-in PLC function are up counters.

An up counter stops counting and its contact turns on when the count value reaches the setting.

### (1) Count processing

- 1) The coil of the counter is turned on/off at execution of the OUT C□ instruction, and its present value is updated and its contact turns on after execution of the END instruction.
- 2) The counter counts on detection of the leading edge (OFF to ON) of the coil. It does not count if the coil remains on.

### (2) Counter resetting

- 1) The count value is not cleared even if the coil turns off. Use the RST C□ instruction to clear the count value and turn off the contact.
- 2) When the counter is reset by the RST instruction, the present value and contact of the counter are cleared at execution of the RST instruction.

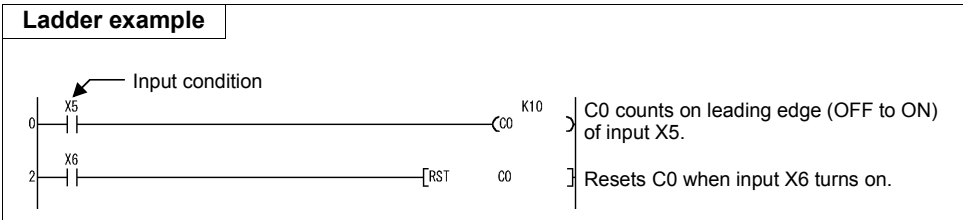

Fig 3.18 Count Ladder

### 3.10.1 Count processing in refresh system

The counter counts on the leading edge of the input condition of the counter imported at an input refresh.

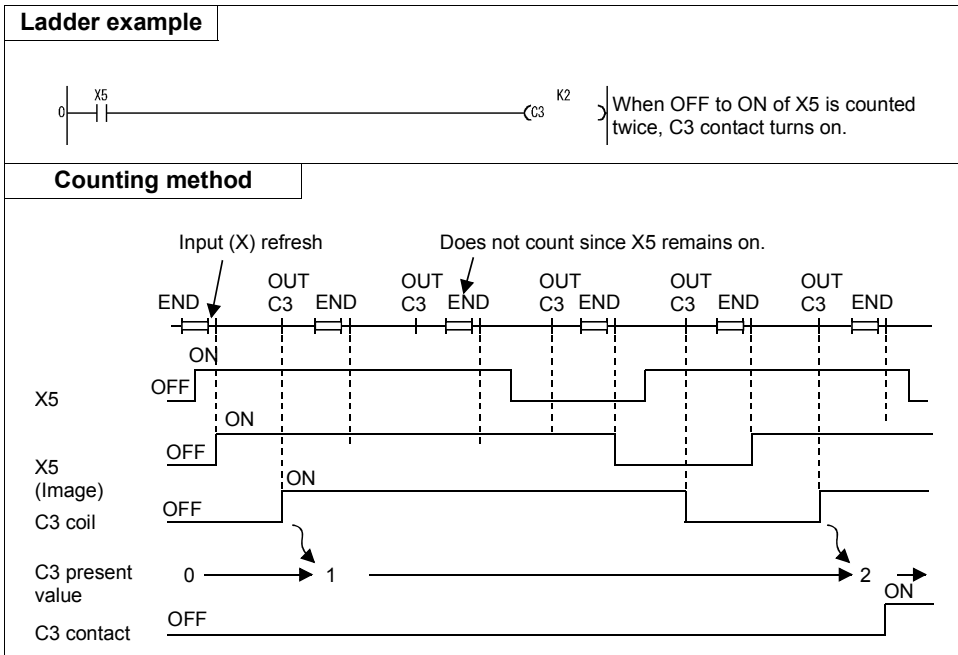

Fig 3.19 Counter Counting Method

#### REMARKS

Refer to page 92 for the maximum counting speed of the counter.



### 3.10.2 Maximum counting speed of counter

The maximum counting speed of the counter is determined by the scan time, and the counter can count only when the ON/OFF period of the input condition is longer than the scan time.

$$\text{Maximum counting speed } C_{\max} = \frac{n}{100} \times \frac{1}{t_s} \text{ [times/s]} \quad \begin{array}{l} n: \text{Duty (\%)} \\ t_s: \text{Scan time [s]} \end{array}$$

#### REMARKS

The duty  $n$  is a percent (%) ratio of ON/OFF period to (ON + OFF period) of the count input signal.

$$\text{When } T_1 \leq T_2 \quad n = \frac{T_1}{T_1 + T_2} \times 100[\%]$$

$$\text{When } T_1 > T_2 \quad n = \frac{T_2}{T_1 + T_2} \times 100[\%]$$

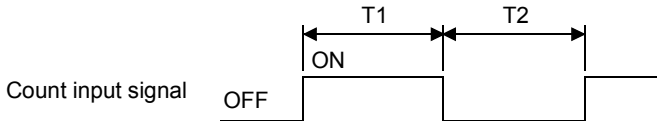

### 3.11 Data registers D

- (1) Data registers are memories that can store numerical data (-32768 to 32767 or H0000 to HFFFF) in the built-in PLC function.

One point of data register consists of 16 bits and allows data to be read/written in units of 16 bits.

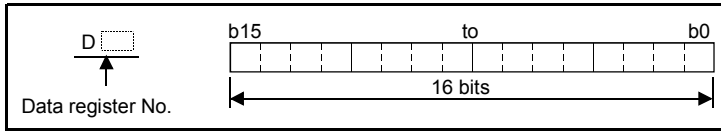

Fig 3.20 Data Register Structure

- (2) The data stored once by the sequence program is maintained until other data is stored.
- (3) If more data registers are needed, the unused timers (T) and counters (C) can be used as data registers.



## 3.12 Special relays, special registers

---

Special relays and special registers are internal relays and data registers, respectively, whose applications are predetermined by the built-in PLC functions.

They have the following main applications.

(1) Sequence operation check

The special relays and special registers can be used to:

- (a) Check the operating status (RUN/STOP)
- (b) Detect a fault by the self-diagnostic function
- (c) Detect an operation error
- (d) Check the scan time

(2) Timing contact

There are special relays that can be used in a sequence program and differ in operating status.

- (a) Normally ON/OFF flag
- (b) RUN flag (OFF for 1 scan)
- (c) Initial processing flag (ON for 1 scan)

### REMARKS

For the special relays and special registers usable with the built-in PLC function, refer to page 13.

**Table3.4 Special Relay Application List**

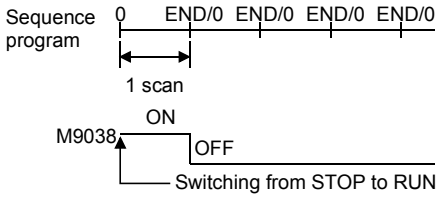
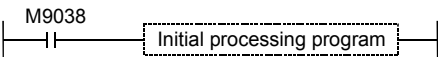
Item	Special Relay	Application/Description
Initial processing flag (1 scan ON)	M9038	<p>(1) This relay turns on for one scan when the built-in PLC function switches from STOP to RUN.</p>  <p>(2) Using M9038, you can create a sequence program to be executed only once without using the PLS instruction at switching from STOP to RUN.</p> 
Normal OFF flag	M9037	This relay remains off while power is on. Can be used to temporarily disable execution for debugging, etc.
Normally ON flag	M9036	This relay is on while power is on. Can be used to create a program to be executed only once after power-on.
RUN flag	M9039	This relay turns on at the second scan of the sequence program when the SQ signal is ON.



## 3.13 Function list

Function	Description
Remote RUN/STOP	<ul style="list-style-type: none"> <li>• This function performs remote RUN/STOP from outside the inverter when the SQ signal is ON (PLC function in RUN status (P.RUN lit)).</li> </ul>
Watchdog timer variable (10 to 2000ms)	<ul style="list-style-type: none"> <li>• The watchdog timer is an internal timer of the sequence function designed to detect hardware or program faults and can be changed in setting.</li> </ul>
Self-diagnostic function	<ul style="list-style-type: none"> <li>• The built-in PLC function itself diagnoses faults and performs fault detection, indication, built-in sequence function stop, etc.</li> </ul>
STOP to RUN-time output setting	<ul style="list-style-type: none"> <li>• This setting is made to determine the output (Y) state when the function has switched from the STOP status to the RUN status.</li> </ul>
Keyword registration	<ul style="list-style-type: none"> <li>• This setting is made to inhibit read/interrupt of a program (parameters and main/sub program) and comments.</li> </ul>

---

### CAUTION

---

The following functions are unavailable.

**Constant scan, latch (backup for power failure), PAUSE, status latch, sampling trace, step run, clock, interrupt processing, comment, microcomputer mode, print title registration, annunciator display mode, ERROR LED priority setting**

---



### 3.14 How to RUN/STOP the built-in PLC function from outside (remote RUN/STOP)

The built-in PLC function is set to RUN/STOP by turning ON/OFF the SQ signal. The remote RUN/STOP is a function that sets RUN/STOP of the built-in PLC function from outside the inverter while the SQ signal is ON (RUN status).

(1) Applications of remote RUN/STOP

In the following cases, the function can be RUN/STOPped by remote operation using remote RUN/STOP.

- 1) When the inverter is out of reach.
- 2) When the inverter in a control box is RUN/STOPped from outside the control box.

(2) Operation performed at remote RUN/STOP

The operation of the sequence program for performing remote RUN/STOP is as described below.

- Remote STOP ..... The function enters the STOP status after the sequence program is executed up to the END instruction.
- Remote RUN ..... When remote RUN is performed after the function has been put in the "STOP status" by remote STOP, the function enters the RUN status again and executes the sequence program from step 0.

(3) Remote RUN/STOP method

There are the following remote RUN/STOP methods.

1) Setting using built-in PLC function parameter (using contact)

Remote RUN/STOP can be performed by turning the remote RUN contact off/on. For example, this method can be used to STOP the PLC function with the emergency stop contact.

- When the remote RUN contact turns off, the function enters the "RUN" status.
- When the remote RUN contact turns on, the function enters the "STOP" status.

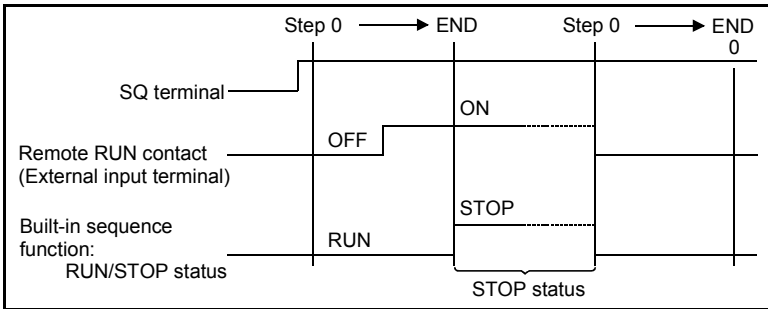

Fig 3.21 Timing Chart for RUN/STOP Using Remote RUN Contact

**POINT**

Setting of remote RUN contact built-in PLC function parameter X0 to X1F can be set as the remote RUN contacts. (Refer to the GX Developer manual for details.)





## 2) Method using GX Developer

RUN/STOP can be performed by remote RUN/STOP operation from GX Developer.

For example, this method can be used to STOP the function for sequence program write in a place where the inverter is out of reach.

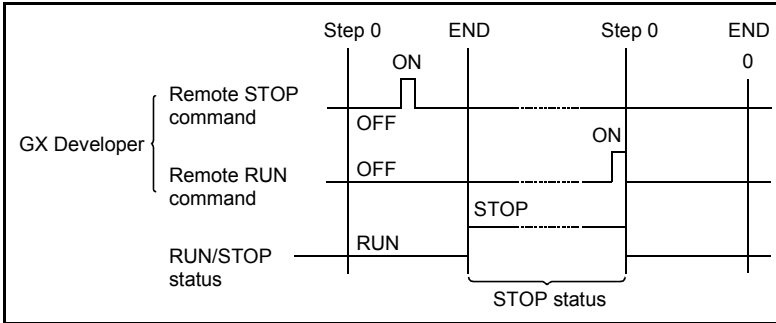

Fig 3.22 Timing Chart for RUN/STOP Using GX Developer

## (4) Instructions

Note the following points since the built-in PLC function gives priority to STOP.

- The built-in PLC function enters the STOP status when remote STOP is performed from any of the remote RUN contact, GX Developer, etc.
- To place the built-in PLC function in the RUN status again after it has been put in the STOP status by remote STOP, all external factors (remote RUN contact, GX Developer, etc.) for remote STOP must be set to RUN.

### REMARKS

What are RUN and STOP statuses?

- RUN status..... Status where a sequence program is repeating operation from step 0 to END instruction.
- STOP status ..... Status where sequence program operation is at a stop and the outputs (Y) are all off.

## 3.15 Watchdog timer (operation clog up monitor timer)

### (1) Watchdog timer

A watchdog timer is the internal timer of the built-in PLC function designed to detect hardware or sequence program faults.

Its default value is set to 200ms.

### (2) Watchdog timer resetting

The built-in PLC function resets the watchdog timer before execution of step 0 (after execution of END processing).

When the built-in PLC function operates properly and the END instruction is executed within the setting in the sequence program, the watchdog timer does not time out.

If the hardware fault of the built-in PLC function occurs or the scan time of the sequence program is too long to execute the END instruction within the setting, the watchdog timer times out.

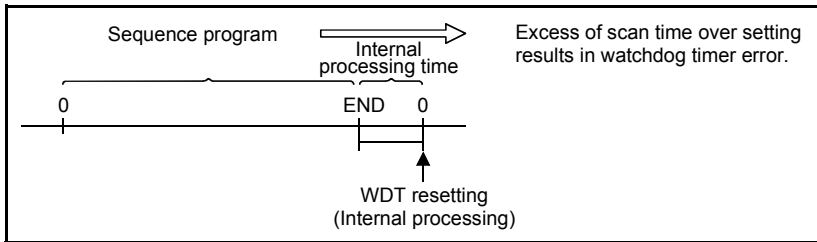

Fig 3.23 Watchdog Timer Resetting

### (3) Processing performed when watchdog timer times out

If the scan time exceeds the watchdog timer setting, a watchdog timer error occurs and:

- 1) The built-in PLC function turns off all outputs.
- 2) The P.RUN LED goes off or flickers.
- 3) M9008 turns on and the error code is stored into D9008.

### REMARKS

The watchdog timer setting can be changed by built-in PLC function parameter setting of GX Developer. (Refer to the GX Developer manual for details.)



## 3.16 Self-diagnostic function

---

The self-diagnostic function diagnoses faults by the built-in PLC function itself.

(1) Self-diagnostic timing

The self-diagnostic function is performed at power-on, at reset, at execution of any instruction, or at execution of the END instruction.

1) At power-on, at reset

Whether operation can be executed or not is diagnosed.

2) At execution of any instruction

An error occurs if the operation of any instruction in the sequence program is not executed properly.

---

**CAUTION**

---

**For the LD, AND, OR, logical comparison operation, and OUT instructions, the set devices are always checked. For the other instructions (SET, RST, MOV, etc.), a check is made as soon as the execution condition holds and the instruction is ready to be executed.**

---

3) At execution of END instruction

Operation clog up monitor timer

(2) Operation mode at fault detection

There are two different PLC operation modes at detection of a fault by the self-diagnostic: operation stop mode and operation continuation mode.

The operation continuation mode includes a fault that enables operation to be stopped by built-in PLC function parameter setting. (*Refer to page 101*)

1) If an operation stop error is detected by the self-diagnostic, operation is stopped and outputs (Y) are all turned off as soon as the error is detected. The other devices maintain their states at occurrence of the error.

2) If an operation continuation error is detected, only the faulty program part is not executed and the program at the next step is executed.

(3) Error definition checking

When M9008 (self-diagnostic error) turns on at detection of an error, the error code is stored into D9008 (self-diagnostic error). Especially in the continuation mode, use it in the program to prevent a mechanical system malfunction.

For the errors detected by the self-diagnostic, refer to the error code list on *page 202*.

### 3.16.1 Error-time operation mode

The built-in PLC function allows you to set whether the sequence program operation will be stopped or continued at occurrence of an operation error.

Use the built-in PLC function parameter to set whether operation will be stopped or continued.

- Default value of error-time operation mode

The following table indicates the default value (initial value) of the error-time operation mode and the status of the built-in PLC function.

Table 3.5 Error-time Operation Mode

Error Definition		CPU Status				
		Operation	P.RUN LED	Special relays turned on	Special registers for data storage	Self- diagnostic error No. (D9008)
		Default value				
Operation error	An error occurred in the sequence program, e.g. an attempt was made to make BCD conversion of any value outside the range 0 to 9999 (or 0 to 99999999).	Continuation	On	M9010 M9011	D9010 D9011	50



## 3.17 Keyword registration

---

The keyword is designed to inhibit the read and rewrite of the program and comments in the built-in PLC function using GX Developer.

- (1) Read/write from built-in PLC function where keyword has been registered  
When the keyword has been registered, the built-in PLC function parameters, main program and comments cannot be read/written from the built-in PLC function to the GX Developer device unless the keyword registered to the built-in PLC function is entered.
- (2) Registration and cancel of keyword  
A keyword of up to six digits can be set in hexadecimal (0 to 9, A to F).  
Make built-in PLC function parameter setting to register or cancel the keyword.

### REMARKS

- Parameter settings in the inverter can be read/written using GX Developer even when the password function (*Pr.296, Pr.297*) is valid. To use the password function and the PLC function at the same time, apply a lock to reading/writing of the ladder program by registering a keyword.

### 3.18 Setting of output (Y) status at switching from STOP status to RUN status

When the RUN status is switched to the STOP status, the outputs (Y) in the RUN status are stored into the built-in PLC function.

Using the built-in PLC function parameter, you can set whether the outputs (Y) will be output again or will be output after execution of operation when the STOP status is switched to the RUN status.

"Output (Y) status at STOP is output"

The sequence program operation is performed after the output (Y) status at the time of entering the STOP status is output.

"Outputs (Y) are cleared (output one scan later)"

The outputs (Y) are all cleared, and after execution of the sequence program operation, the outputs are provided.

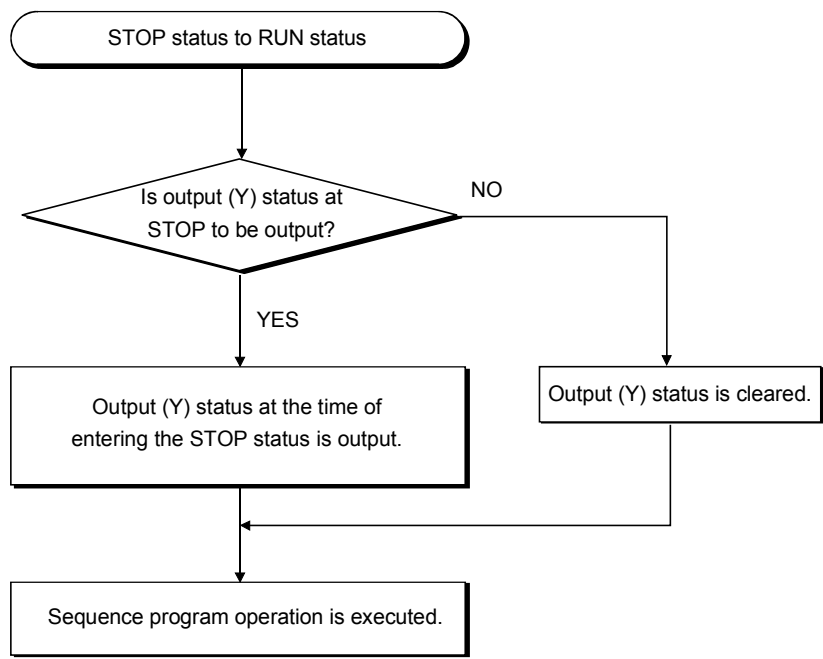

Fig 3.24 Processing Performed when STOP Status Is Switched to RUN Status



## 3.19 Instruction format

(1) Many of the instructions can be divided into an instruction part and a device, and their applications are as described below.

- { Instruction part ..... Indicates the function of that instruction.
- { Device ..... Indicates the data used with the instruction.

(2) The instruction format can be roughly classified as follows according to the instruction part and device combinations.

1) Instruction part .....This instruction does not change the device status and mainly controls the program.

Example END

2) Instruction part + Device .....This instruction performs ON/OFF control of the device, controls the execution condition according to the ON/OFF status of the device, and branches the program.

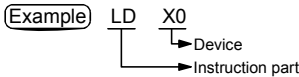

3) Instruction part + Source device + Destination device ..... This instruction performs operation using the data of the destination and source, and stores the operation result into the destination.

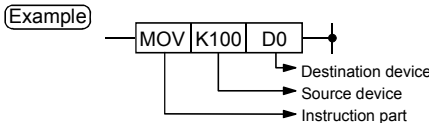

4) Others .....Combinations other than the above 1) to 3).

## (3) Source (S)

The source contains the data to be used for operation.

The data changes depending on the specified device.

- Constant.....Specify the numerical value to be used for operation. Since this value is set at the time of program creation, it is fixed and cannot be changed during program execution.
- Bit device.....Specify the device that stores the data to be used for operation. Therefore, the data must have been stored into the specified device until operation is executed. By changing the data stored into the specified device during program execution, the data used for that instruction can be changed.
- Word device

## (4) Destination (D)

The destination stores the data resulting from operation. Note that if the format

consists of Instruction part + Source device + Destination device ,

the data to be used for operation must have been stored into the destination before operation.

At the destination, always specify the device for storing data.

**REMARKS**

- In this manual, the source and destination are abbreviated as follows.

Source..... (S)

Source 1..... (S1)

Source 2..... (S2)

Destination..... (D)

Destination 1..... (D1)





## 3.20 Bit device processing method

As the processing method when the bit device (X, Y, M) is specified, 1-bit processing, 16-bit processing and 32-bit processing using digit designation processing are available.

### 3.20.1 1-bit processing

When a PLC instruction is used, the device used as the target of operation processing is one bit (one point) of bit device, and multiple bits cannot be specified.

**Example** LD XO,OUT

### 3.20.2 Digit designation processing

When a basic or application instruction is used, the bit device used as the target of operation processing may have to be specified by digit designation. When the instruction whose processing unit is 16 bits is specified by this digit designation, up to 16 points can be specified in units of four points.

#### (1) 16-bit instruction: K1 to 4 (4 to 16 points)

**Example** Setting ranges of 16-bit data, X0 to F, by digit designation

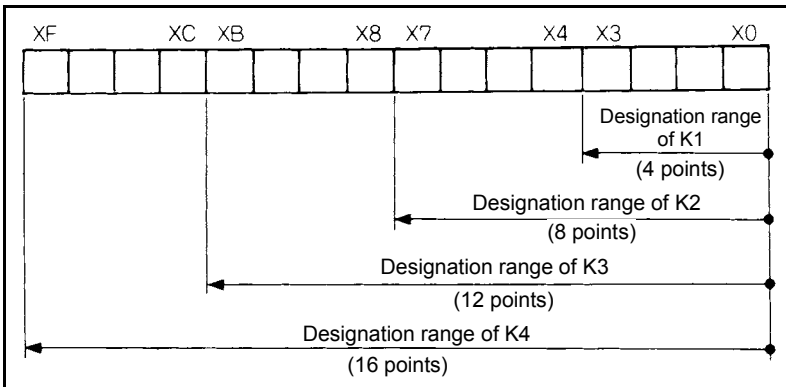

Fig 3.25 Digit Designation Setting Range for 16-bit Instruction

(a) When there is digit designation on the source (S) side, the numerical values that can be handled as the source data are as indicated in Table 3.6.

Table 3.6 List of Designated Digits and Numerical Values That Can Be Handled

Number of Designated Digits	16-bit Instruction
K1 (4 points)	0 to 15
K2 (8 points)	0 to 255
K3 (12 points)	0 to 4095
K4 (16 points)	-32768 to 32767

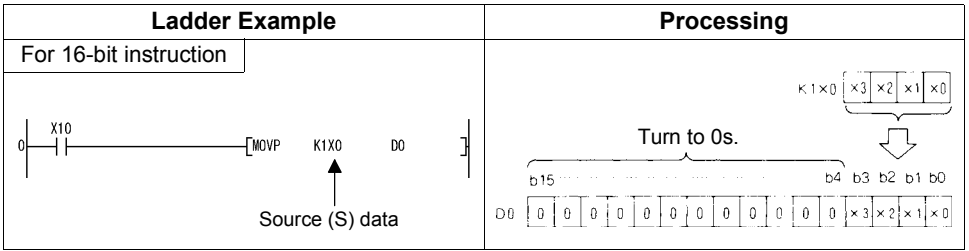

Fig 3.26 Ladder Example and Processing

(b) When there is digit designation on the destination (D) side, the number of points specified by digit designation is the target on the destination side.

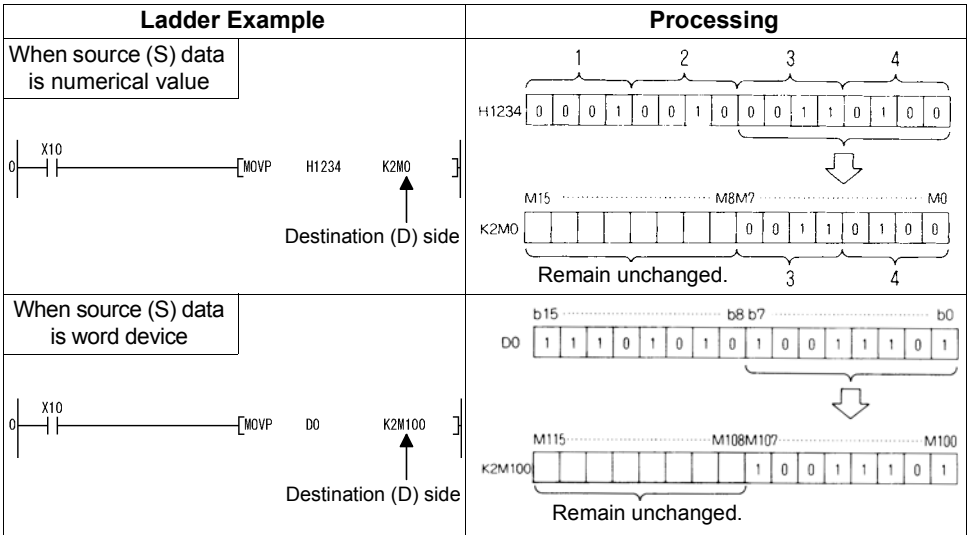

Fig 3.27 Ladder Examples and Processings



(2) 32-bit instruction: K1 to 8 (4 to 32 points)

**Example** Setting range by the digit specification of 32-bit data, X0 to 1F

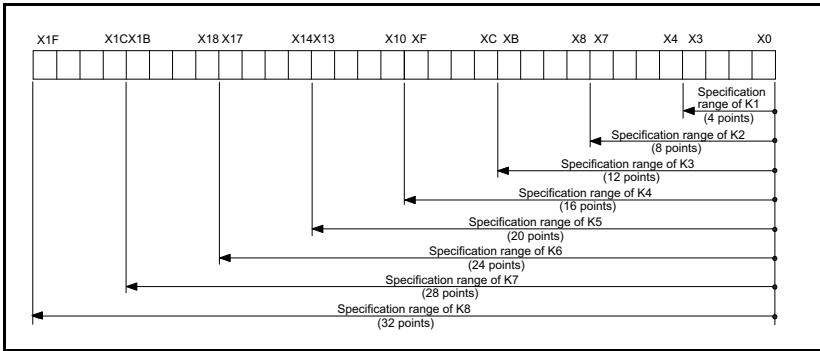

Fig 3.28 Digit Specification Range of 32-Bit Instruction

(a) When there is digit specification on the source(S)side, the range of numeric values handled as source data are as shown in Table 3.7.

Table 3.7 List of Digit Specification and Handled Numeric Values

Specified Number of Digits	32-Bit Instruction	Specified Number of Digits	32-Bit Instruction
K1 (4 points)	0 to 15	K5 (20 points)	0 to 1048575
K2 (8 points)	0 to 255	K6 (24 points)	0 to 16777215
K3 (12 points)	0 to 4095	K7 (28 points)	0 to 268435455
K4 (16 points)	0 to 65535	K8 (32 points)	-2147483648 to 2147483647

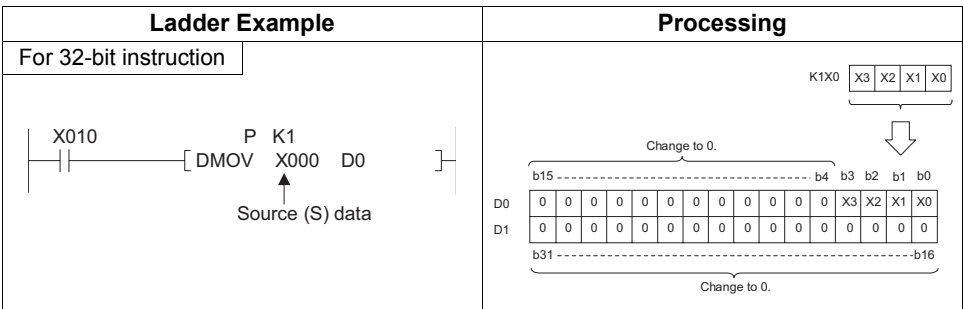

Fig 3.29 Ladder Example and Processing

(b) When there is digit specification on the destination (D) side, the number of points set by the digit specification is used on the destination side.

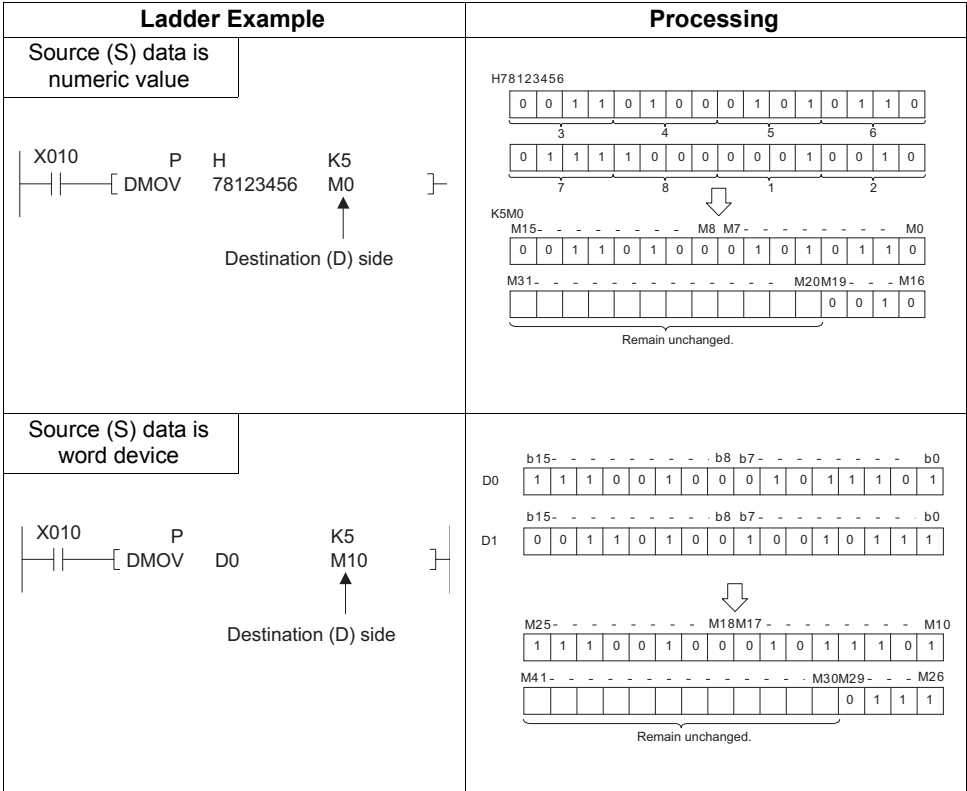

Fig 3.30 Ladder Example and Processing

**CAUTION**

•When storing a 32-bit data to word devices, the data is saved in two continuous word devices. If the data is larger than the storable size of the applicable devices, the exceeded data will modify other devices although no error will occur. Before storing data, make sure to have enough devices available to store the data.



## 3.21 Handling of numerical value

The built-in PLC function has instructions that handle numerical values indicated in 16-bit and 32-bit.

The most significant bit of the 16-bit or 32-bit are used to indicate whether the value is positive or negative. Therefore, the numerical values that can be handled are as follows.

16-bit: -32768 to 32767

32-bit: -2147483648 to 2147483647

### POINT

#### • Numerical value setting method

##### 1) Decimal number

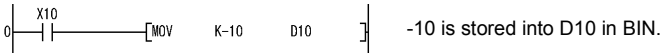

##### 2) Hexadecimal number



The decimal notation and hexadecimal notation correspond as indicated below.

#### • 16 bits

Decimal Notation	Hexadecimal Notation
32767	H7FFF
:	:
5	H0005
4	H0004
3	H0003
2	H0002
1	H0001
0	H0000
-1	HFFFF
-2	HFFFE
-3	HFFFD
-4	HFFFC
-5	HFFFB
:	:
-32768	H8000

#### • 32 bits

Decimal Notation	Hexadecimal Notation
2147483647	H7FFFFFFF
:	:
5	H00000005
4	H00000004
3	H00000003
2	H00000002
1	H00000001
0	H00000000
-1	HFFFFFFF
-2	HFFFFFFFE
-3	HFFFFFFFD
-4	HFFFFFFFC
-5	HFFFFFFFB
:	:
-2147483648	H80000000

### 3.22 Operation error

When a basic instruction is used, an operation error will occur in the following case.

- (a) If any error described in the description of the corresponding instruction occurs.

**POINT**

**Note that if the device designation range is outside the corresponding device range, an operation error does not occur and data is written to other than the specified device.**

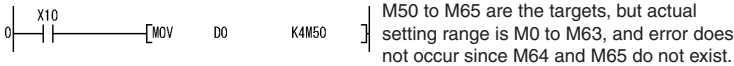

#### (1) Error processing

If an operation error occurred at execution of a basic instruction, the error flag turns on and the error step number is stored into the error step storage register.

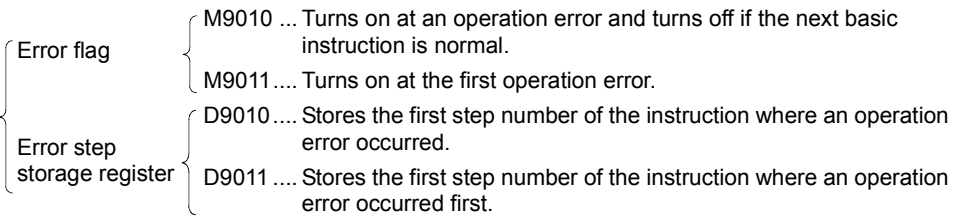

- 1) D9011 stores the step number of the instruction where an operation error occurred when M9011 turned from OFF to ON. Therefore, D9011 data does not change if M9011 remains on.
- 2) To reset M9011 and D9011, program as shown below.

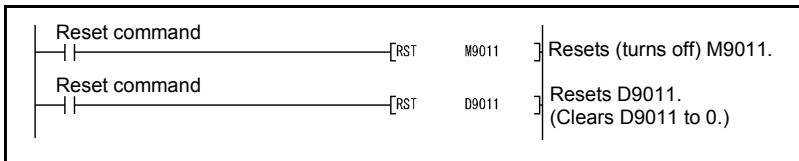

Fig 3.31 Special Relay and Register Resetting Ladder

- 3) Whether sequence processing will be stopped or continued at occurrence of an operation error can be selected by built-in PLC function parameter setting. Refer to page 101 for details.



## 3.23 Instructions list

### 3.23.1 How to use the instruction list

Classification	Instruction Symbol	Symbol	Processing	Execution Condition	Number of Steps
Transfer	MOV	MOV (S) (D)	(S) → (D)		5
	MOVP	MOVP (S) (D)			
↑ 1)	↑ 2)	↑ 3)	↑ 4)	↑ 5)	↑ 6)

1).....Classifies the instruction by application.

2).....Indicates the instruction symbol used for programming.

- The standard instruction symbol is for 16-bit commands. Modify the instruction symbol as shown below for the 32-bit commands.  
32-bit command .....Add D to the front of the instruction.

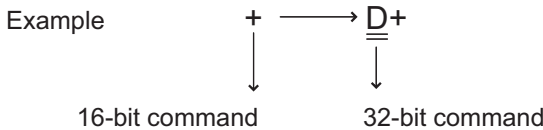

- Modify the instruction symbol as shown below for the start-up execution command at turn ON.

Add P to the end of the instruction to define it as executed only on the leading edge of the preceding condition.

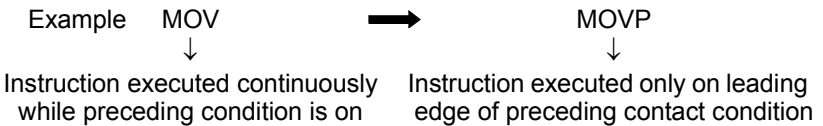

3).....Indicates the symbol used in the ladder diagram.

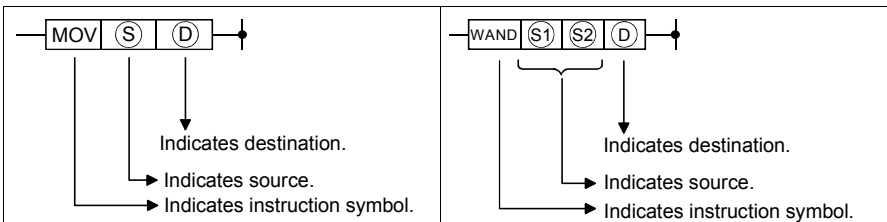



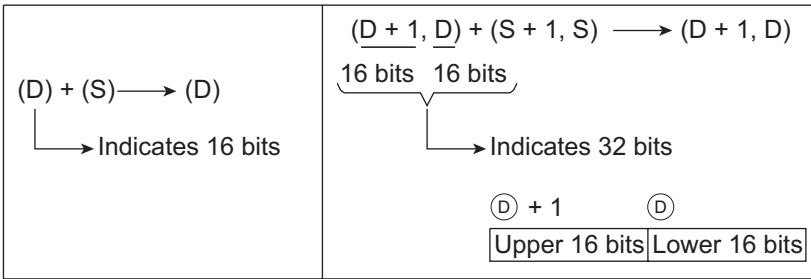

Destination:..... Indicates the destination of the operation result.

Source:..... Indicates the source of the data for the operation.

4)..... Indicates the operation.



5)..... Indicates the condition of execution for each instruction as described below:

Symbol	Execution Condition
No entry	The instruction is always executed independently of whether its preceding condition is on or off. When the preceding condition is off, the instruction is off.
	The instruction is executed continuously only while its preceding condition is on. When the preceding condition is off, the instruction is not executed and not processed.
	The instruction is executed once only when the preceding condition turns from off to on. If the condition remains on after that, the instruction is not executed and not processed.
	The instruction is executed continuously only while its preceding condition is off. When the preceding condition is on, the instruction is not executed and not processed.
	The instruction is executed once only when the preceding condition turns from on to off. If the condition remains off after that, the instruction is not executed and not processed.

6)..... Indicates the number of program steps required for each instruction.





### 3.2.3.2 Sequence instruction

Classification	Instruction Symbol	Symbol	Processing	Execution Condition	Number of Steps	Reference page
Contacts	LD		Logical operation start (Operation start at N/O contact)		1	122
	LDI		Logical NOT operation start (Operation start at N/C contact)		1	
	AND		Logical product (N/O contact series connection)		1	
	ANI		Logical product NOT (N/C contact series connection)		1	
	OR		Logical sum (N/O contact parallel connection)		1	
	ORI		Logical sum NOT (N/C contact parallel connection)		1	
Connection	ANB		AND between logical blocks (series connection between blocks)		1	125
	ORB		OR between logical blocks (parallel connection between blocks)		1	
	MPS		Stores the operation result.		1	128
	MRD		Reads the operation result stored in MPS.		1	
	MPP		Reads and resets the operation result stored in MPS.		1	
OUT			Outputs device.		1/3	131
Outputs	SET		Sets device.		1/3	134
	RST		Resets device.		1/3	
	PLS		Produces a pulse lasting one program scan time on the leading edge of input signal.		3	137
	PLF		Produces a pulse lasting one program scan time on the trailing edge of input signal.		3	
	Shift	SFT		1-bit device shift		3
SFTP					3	

Classification	Instruction Symbol	Symbol	Processing	Execution Condition	Number of Steps	Reference page
Master control	MC		Master control start		5	141
	MCR		Master control reset		3	
Program end	END	—	Must be written at the end of sequence program to return to step 0.		1	145
No operation	NOP	—	No operation For program deletion or space		1	146
	NOPLF	—	No operation Line feed instruction for printer output		1	-



### 3.23.3 Basic instructions

Classification	Instruction Symbol	Symbol	Processing	Execution Condition	Number of Steps	Reference page
16-bit data comparison	LD=		Continuity when (S1) = (S2) Non-continuity when (S1) ≠ (S2)		5 7	148
	AND=				5 7	
	OR=				5 7	
	LD<>		Continuity when (S1) ≠ (S2) Non-continuity when (S1) = (S2)		5 7	
	AND<>				5 7	
	OR<>				5 7	
	LD>		Continuity when (S1) > (S2) Non-continuity when (S1) ≤ (S2)		5 7	
	AND>				5 7	
	OR>				5 7	
	LD≤		Continuity when (S1) ≤ (S2) Non-continuity when (S1) > (S2)		5 7	
	AND≤				5 7	
	OR≤				5 7	
	LD<		Continuity when (S1) < (S2) Non-continuity when (S1) ≥ (S2)		5 7	
	AND<				5 7	
	OR<				5 7	
	LD≥		Continuity when (S1) ≥ (S2) Non-continuity when (S1) < (S2)		5 7	
	AND≥				5 7	
	OR≥				5 7	
32-bit data comparison	LDD=		Continuity when (S1+1, S1) = (S2+1, S2) Non-continuity when (S1+1, S1) ≠ (S2+1, S2)		11	163
	ANDDD=				11	
	ORD=				11	

Classification	Instruction Symbol	Symbol	Processing	Execution Condition	Number of Steps	Reference page
32-bit data comparison	LDD<>		Continuity when (S1+1, S1) ≠ (S2+1, S2) Non-continuity when (S1+1, S1) = (S2+1, S2)		11	163
	ANDD<>				11	
	ORD<>				11	
	LDD>		Continuity when (S1+1, S1) > (S2+1, S2) Non-continuity when (S1+1, S1) ≤ (S2+1, S2)		11	
	ANDD>				11	
	ORD>				11	
	LDD<=		Continuity when (S1+1, S1) ≤ (S2+1, S2) Non-continuity when (S1+1, S1) > (S2+1, S2)		11	
	ANDD<=				11	
	ORD<=				11	
	LDD<		Continuity when (S1+1, S1) < (S2+1, S2) Non-continuity when (S1+1, S1) ≥ (S2+1, S2)		11	
	ANDD<				11	
	ORD<				11	
LDD>=		Continuity when (S1+1, S1) ≥ (S2+1, S2) Non-continuity when (S1+1, S1) < (S2+1, S2)		11		
ANDD>=				11		
ORD>=				11		
16-bit transfer	MOV		(S) → (D)		5	161
	MOV <sub>P</sub>				5	
32-bit transfer	DMOV		(S+1,S) → (D+1,D)		7	176
	DMOV <sub>P</sub>				7	



Classification	Instruction Symbol	Symbol	Processing	Execution Condition	Number of Steps	Reference page
BIN 16-bit addition/subtraction			$(S) + (D) \rightarrow (D)$		5	153
					5	
			$(S1) + (S2) \rightarrow (D)$		7	
					7	
			$(S) - (D) \rightarrow (D)$		5	
					5	
			$(S1) - (S2) \rightarrow (D)$		7	
					7	
BIN 32-bit addition/subtraction			$(D+1,D) + (S+1,S) \rightarrow (D+1,D)$		9	168
					9	
			$(S1+1,S1) + (S2+1,S2) \rightarrow (D+1,D)$		11	
					11	
			$(D+1,D) - (S+1,S) \rightarrow (D+1,D)$		9	
					9	
			$(S1+1,S1) - (S2+1,S2) \rightarrow (D+1,D)$		11	
					11	

Classification	Instruction Symbol	Symbol	Processing	Execution Condition	Number of Steps	Reference page
BIN 16-bit multiplication /division	*		$(S1) \times (S2) \rightarrow (D+1, D)$		7	157
	*P				7	
	/		$(S1) / (S2) \rightarrow \text{Quotient (D)}, \text{Remainder (D+1)}$		7	
	/P				7	
BIN 32-bit multiplication /division	D*		$(S1+1, S1) \times (S2+1, S2) \rightarrow (D+3, D+2, D+1, D)$		11	172
	D*P				11	
	D/		$(S1+1, S1) / (S2+1, S2) \rightarrow \text{Quotient (D+1, D)}, \text{Remainder (D+3, D+2)}$		11	
	D/P				11	



### 3.23.4 Application instructions

Classification	Instruction Symbol	Symbol	Processing	Execution Condition	Number of Steps	Reference page
Logical product	WAND		(D) AND (S) → (D)		5	179
	WANDP				5	
	WAND		(S1) AND (S2) → (D)		7	
	WANDP				7	
Logical sum	WOR		(D) OR (S) → (D)		5	182
	WORP				5	
	WOR		(S1) OR (S2) → (D)		7	
	WORP				7	
Exclusive logical sum	WXOR		(D) XOR (S) → (D)		5	185
	WXORP				5	
	WXOR		(S1) XOR (S2) → (D)		7	
	WXORP				7	
NOT exclusive logical sum	WXNR		$\overline{(D) \text{ XOR } (S)} \rightarrow (D)$		5	188
	WXNRP				5	
	WXNR		$\overline{(S1) \text{ XOR } (S2)} \rightarrow (D)$		7	
	WXNRP				7	
2's complement	NEG		0 - (D) → (D)		3	191
	NEGP				3	
PU display customization	PR		For the device specified by (S), register the data to be displayed on FR-PU07-01.		7	193
ASCII conversion	ASC		Converts alphanumeric characters into ASCII codes and stores into 4 points beginning with the devices, D.		13	198

## 3.24 Description of the instructions

In Chapter 3, the instructions are described in the following format.

**Output Instructions**

1) → **6.5.2 Device set, reset ... SET, RST**

	Usable Devices										Digit Designation	Error Flag (M9010, M9011)
	Bit devices			Word (16-bit) devices				Constants		Level		
	X	Y	M	T	C	D	K	H	N			
2) → SET		○	○									
RST		○	○	○	○	○						

3) 4)

5) →

SET	D	Device number to be set (turned on)
RST	D	Device number to be reset

6) → **Functions**

**SET**

- (1) Turns on the specified device when the SET input turns on.
- (2) The device turned on is held on if the SET input turns off. It can be turned off by the RST instruction.

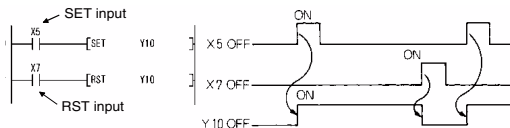

- (3) When the SET input is off, the device status does not change.

7) → **Execution Conditions**

The SET and RST instructions are executed every scan.

8) → **Program Examples**

**SET**, **RST**

- 1) Program that sets (turns on) Y8 when X8 turns on and resets (turns off) Y8 when X9 turns on.

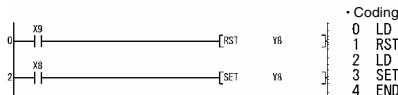

- Coding

0	LD	X9
1	RST	Y8
2	LD	X8
3	SET	Y8
4	END	

### Description

- 1) Indicates the section number, instruction outlines and instruction symbols.
- 2) The devices usable with the instructions are marked.
- 3) The digit designation that can be set is indicated for the instruction that requires digit designation when a bit device is used.
- 4) The instruction for which the error flag turns on at operation error occurrence is marked.
- 5) Shows the format in the ladder mode.
- 6) Explains the instruction.
- 7) Indicates the execution conditions of the instructions.
- 8) Shows program examples in the ladder mode and list mode.





## 3.25 Sequence instructions

Sequence instructions are used for relay control circuits, etc.

### 3.25.1 Contact Instructions : Operation start, series connection, parallel connection ... LD, LDI, AND, ANI, OR, ORI

Usable Devices									Digit Designation	Error Flag (M9010, M9011)
Bit devices			Word (16-bit) devices			Constants		Level		
X	Y	M	T	C	D	K	H	N		
○	○	○	○	○						

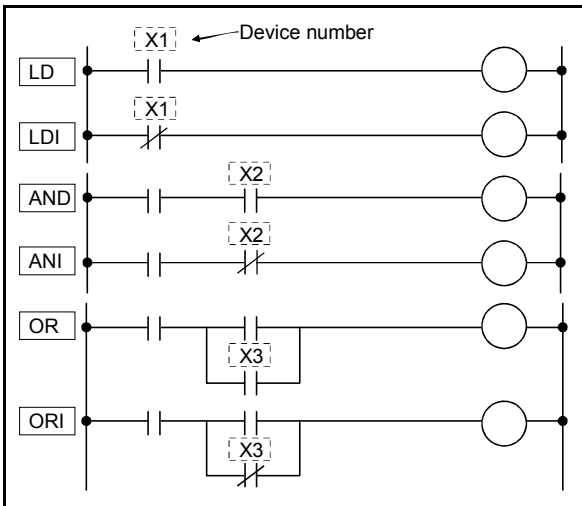

## Functions

### LD, LDI

- (1) LD is an N/O contact operation start instruction, and LDI is an N/C contact operation start instruction. Each of them imports the ON/OFF data of the specified device and uses it as an operation result.

### AND, ANI

- (1) AND is an N/O contact series connection instruction, and ANI is an N/C contact series connection instruction. Each of them imports the ON/OFF data of the specified device, ANDs it with the previous operation result, and uses the resultant value as an operation result.
- (2) There are no restrictions on the use of AND and ANI, but there are the following conditions in the ladder mode.
  - 1) Write .....When contacts are connected in series by AND or ANI, a ladder of up to 21 contacts can be created.
  - 2) Read .....When contacts are connected in series by AND or ANI, a ladder of up to 24 contacts can be displayed. If the ladder has more than 24 contacts, up to 24 contacts are displayed.

### OR, ORI

- (1) OR is an N/O contact parallel connection instruction, and ORI is an N/C contact parallel connection instruction. Each of them imports the ON/OFF data of the specified device, ORs it with the previous operation result, and uses the resultant value as an operation result.
- (2) There are no restrictions on the use of OR and ORI, but there are the following conditions in the ladder mode.
  - 1) Write .....A ladder of up to 23 contacts connected consecutively by OR or ORI can be created.
  - 2) Read .....A ladder of up to 23 contacts connected consecutively by OR or ORI can be displayed. If the ladder has more than 23 contacts, it cannot be displayed properly.

## Execution Conditions

Executed every scan independently of the device ON/OFF and preceding operation result.



## Program Examples

LD , LDI , AND , ANI , OR , ORI

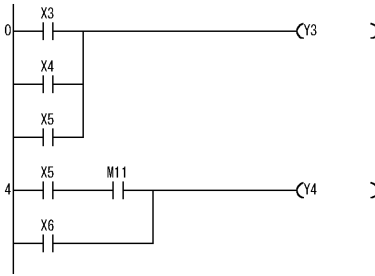

· Coding

```

0 LD      X3
1 OR     X4
2 OR     X5
3 OUT    Y3
4 LD     X5
5 AND   M11
6 OR
7 OUT    Y4
8 END
    
```

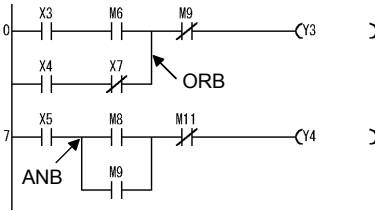

· Coding

```

0 LD      X3
1 AND    M6
2 LD     X4
3 ANI   X7
4 ORB
5 ANI   M9
6 OUT    Y3
7 LD     X5
8 LD     M8
9 OR     M9
10 ANB
11 ANI  M11
12 OUT   Y4
13 END
    
```

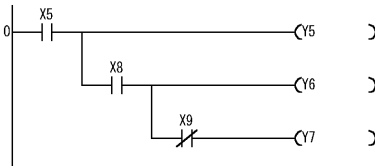

· Coding

```

0 LD     X5
1 OUT    Y5
2 AND   X8
3 OUT    Y6
4 ANI   X9
5 OUT    Y7
6 END
    
```

### 3.25.2 Connection instructions : ladder block series connection, parallel connection ... ANB, ORB

Usable Devices									Digit Designation	Error Flag (M9010, M9011)
Bit devices			Word (16-bit) devices			Constants		Level		
X	Y	M	T	C	D	K	H	N		

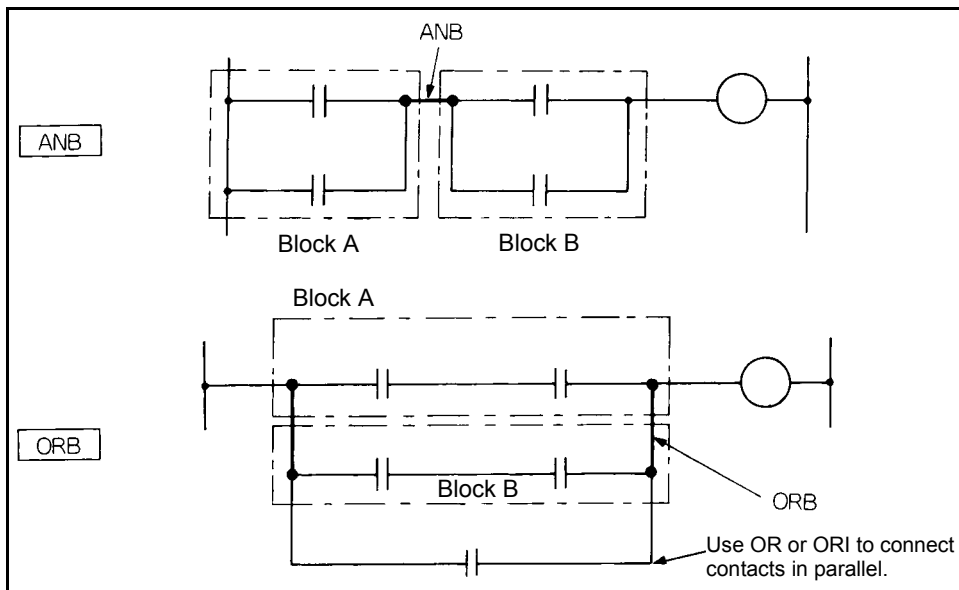



## Functions

### ANB

- (1) ANDs blocks A and B and uses the resultant value as an operation result.
- (2) The symbol of ANB is not a contact symbol but a connection symbol.
- (3) ANB can be written up to seven instructions (eight blocks) consecutively.  
If ANB is written consecutively more than the above, the PLC cannot perform normal operation.

### ORB

- (1) ORs blocks A and B and uses the resultant value as an operation result.
- (2) ORB connects in parallel the ladder blocks of two or more contacts. Use OR or ORI to connect in parallel the ladder blocks of only one contact.

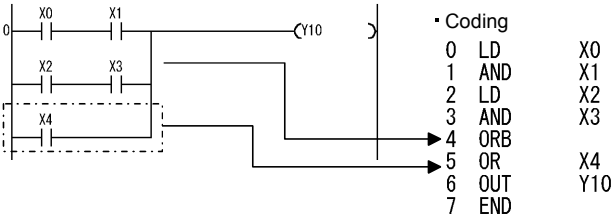

- (3) The symbol of ORB is not a contact symbol but a connection symbol.
- (4) ORB can be written up to seven instructions (eight blocks) consecutively.  
If ORB is written consecutively more than the above, the PLC cannot perform normal operation.



### Program Examples

#### ANB

Though there are the following two different program coding methods for connecting ladder blocks in series consecutively, use the coding example 1.

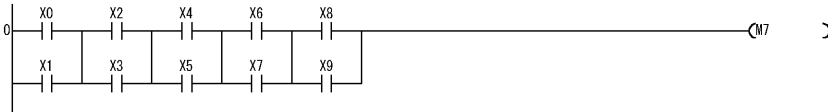

• Coding example 1

```

0 LD X0
1 OR X1
2 LD X2
3 OR X3
4 ANB
5 LD X4
6 OR X5
7 ANB
8 LD X6
9 OR X7
10 ANB
11 LD X8
12 OR X9
13 ANB
14 OUT M7
15 END

```

• Coding example 2

```

0 LD X0
1 OR X1
2 LD X2
3 OR X3
4 LD X4
5 OR X5
6 LD X6
7 OR X7
8 LD X8
9 OR X9
10 ANB
11 ANB
12 ANB
13 ANB
14 OUT M7
15 END

```

#### ORB

Though there are the following two different program coding methods for connecting ladder blocks in parallel consecutively, use the coding example 1.

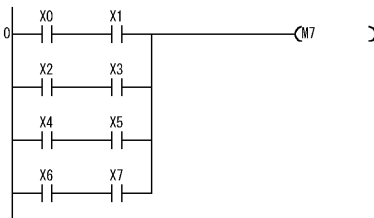

• Coding example 1

```

0 LD X0
1 AND X1
2 LD X2
3 AND X3
4 ORB
5 LD X4
6 AND X5
7 ORB
8 LD X6
9 AND X7
10 ORB
11 OUT M7
12 END

```

• Coding example 2

```

0 LD X0
1 AND X1
2 LD X2
3 AND X3
4 LD X4
5 AND X5
6 LD X6
7 AND X7
8 ORB
9 ORB
10 ORB
11 OUT M7
12 END

```



### 3.25.3 Connection instructions : operation result, push, read, pop ... MPS, MRD, MPP

Usable Devices									Digit Designation	Error Flag (M9010, M9011)
Bit devices			Word (16-bit) devices			Constants		Level		
X	Y	M	T	C	D	K	H	N		

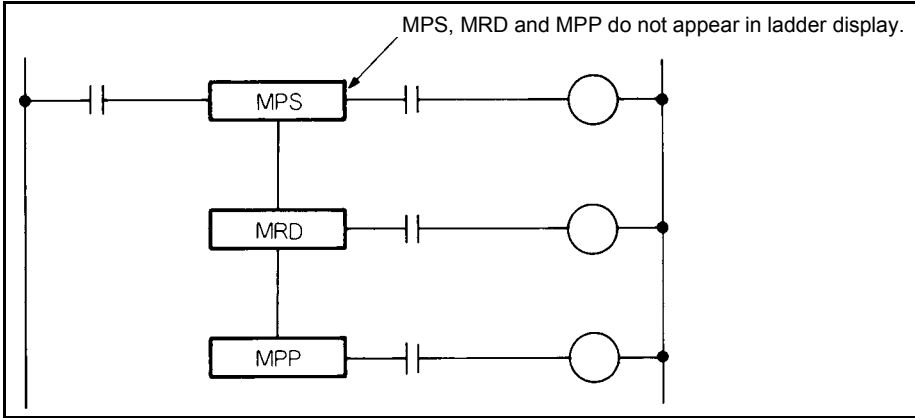

#### Functions

##### MPS

- (1) Stores the operation result (ON/OFF) immediately before itself.
- (2) The MPS instruction can be used consecutively up to 12 times.  
In the ladder mode, however, it can be used up to 11 times.  
When the MPP instruction is used midway, the number of used MPS instructions is decremented by 1.

##### MRD

- (1) Reads the operation result stored by the MPS instruction, and continues operation from the next step with that operation result.

##### MPP

- (1) Reads the operation result stored by the MPS instruction, and continues operation from the next step with that operation result.
- (2) Clears the operation result stored by the MPS instruction.

**POINT**

- (1) Ladders differ as shown below between when MPS, MRD and MPP are used and when they are not used.

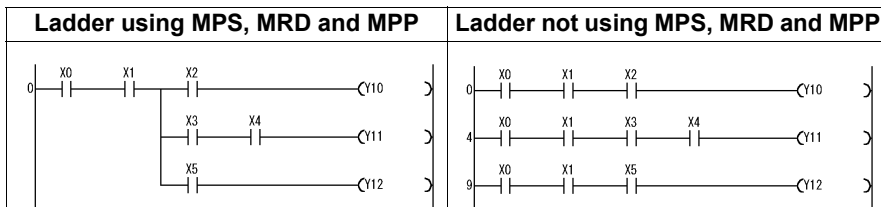

- (2) Use the same number of MPS and MPP instructions. If they differ in the number of used instructions, operation will be performed as described below.
- 1) If the MPS instructions are used more than MPP instructions, the ladder is changed and the built-in PLC function performs operation according to the new ladder.

Before change

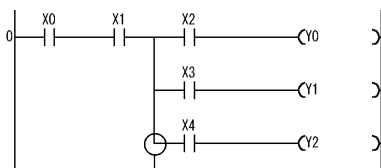

When MPP is replaced by NOP



After change

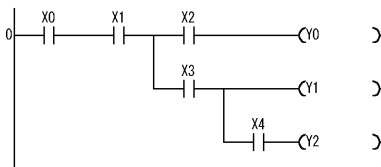

• Coding

```

0 LD      X0
1 AND    X1
2 MPS
3 AND    X2
4 OUT    Y0
5 MRD
6 AND    X3
7 OUT    Y1
8 MPP
9 AND    X4
10 OUT   Y2
11 END
    
```

• Coding

```

0 LD      X0
1 AND    X1
2 MPS
3 AND    X2
4 OUT    Y0
5 MRD
6 AND    X3
7 OUT    Y1
8 NOP
9 AND    X4
10 OUT   Y2
11 END
    
```

- 2) If the MPP instructions are used more than MPS instructions, that ladder block results in a ladder creation error, and the built-in PLC function cannot perform normal operation.





Program Example

MPS , MRD , MPP

1) Program using MPS, MRD and MPP

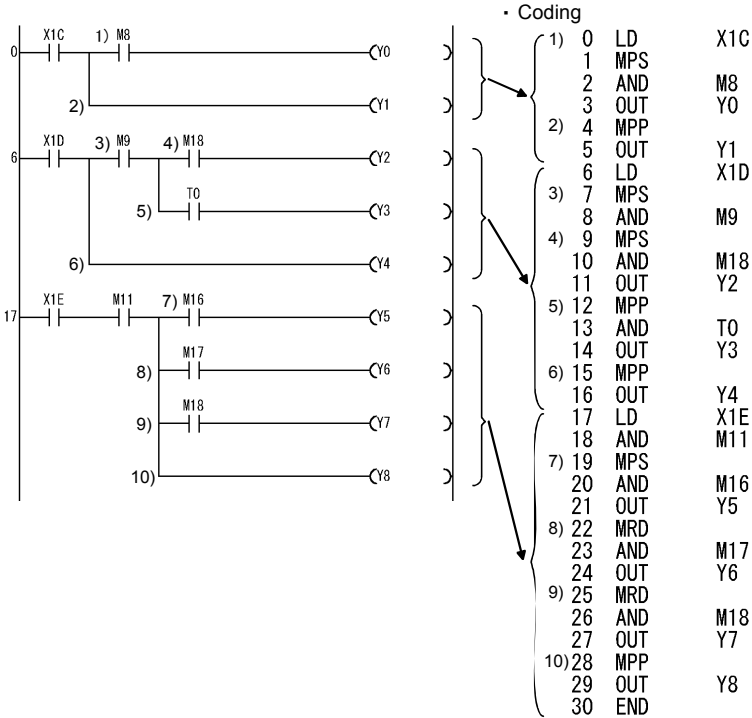

### 3.25.4 Output instructions : bit device, timer, counter ... OUT

		Usable Devices									Digit Designation	Error Flag
		Bit devices			Word (16-bit) devices			Constants		Level		
		X	Y	M	T	C	D	K	H	N		(M9010, M9011)
Bit device			○	○								
Timer	Device				○							
	Setting						○	○				
Counter	Device					○						
	Setting						○	○				

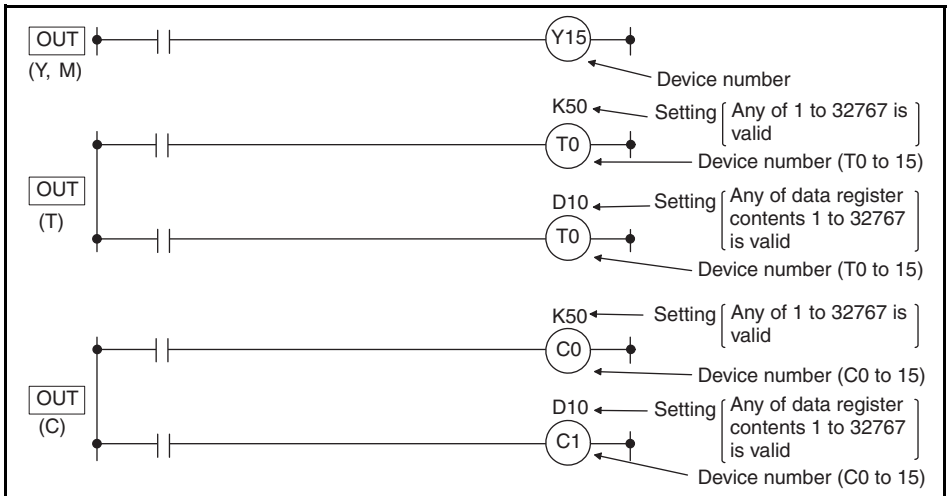

## Functions

### OUT (Y, M)

(1) Outputs the operation result up to OUT instruction to the specified device.

Operation Result	OUT Instruction		
	Coil	Contacts	
		N/O contact	N/C contact
OFF	OFF	Not energize	Energize
ON	ON	Energize	Not energize

### REMARKS

Three steps are used for the OUT instruction only when the following device is used.

- Special relay (M)



## OUT(T)

- (1) When the operation result up to the OUT instruction is ON, the coil of the timer turns on and the timer times up to the setting, and when the timer times out (timing value  $\geq$  setting), the contact operates as indicated below.

N/O contact	Energize
N/C contact	Not energize

- (2) When the operation result up to the OUT instruction turns from ON to OFF, the timer operates as indicated below.

Timer Type	Timer Coil	Present Value of Timer	Before Time-out		After Time-out	
			N/O contact	N/C contact	N/O contact	N/C contact
100ms timer	OFF	0	Not energize	Energize	Not energize	Energize
10ms timer						
100ms retentive timer	OFF	Maintained	Not energize	Energize	Energize	Not energize

- (3) After a time-out, the contact state of the retentive timer remains unchanged until the RST instruction is executed.
- (4) A negative number (-32768 to -1) cannot be specified for the setting.
- (5) If the setting is 0, it is timed as infinity. Hence, the timer does not time out.
- (6) *Refer to page 88* for the timing method of the timer.

## OUT(C)

- (1) When the operation result up to the OUT instruction turns from OFF to ON, the present value (count value) is incremented by 1, and when the counter stops counting (present value = setting), the contact operates as indicated below.

N/O contact	Energize
N/C contact	Not energize

- (2) The counter does not count if the operation result remains ON. (Count inputs need not be converted into pulses.)
- (3) After the counter has stopped counting, the count value and contact state remain unchanged until the RST instruction is executed.
- (4) A negative number (-32768 to -1) cannot be specified for the setting. If the setting is 0, processing is the same as when the setting is 1.
- (5) *Refer to page 90* for the counting method of the counter.

## Execution Conditions

Executed every scan independently of the operation result up to the OUT instruction.



### Program Examples

#### OUT

1) Program that outputs to the output module.

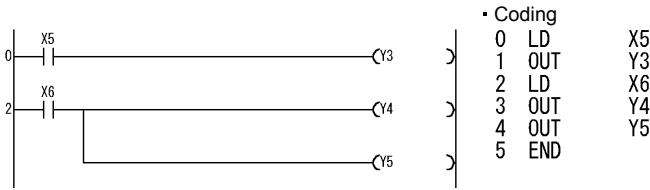

2) Program that turns on Y10 and Y14 10s after X0 has turned on.

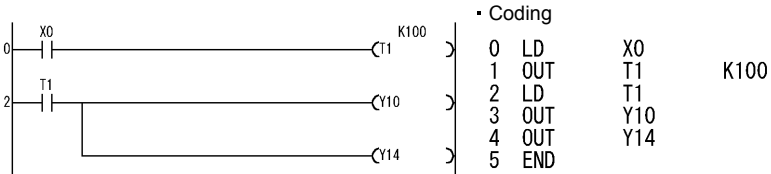

3) Program that turns on Y0 when X0 turns on 10 times and turns off Y0 when X1 turns on.

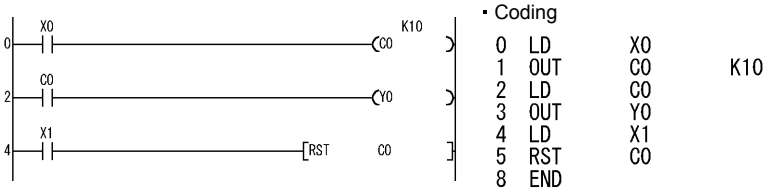

4) Program that changes the C0 setting to 10 when X0 turns on and to 20 when X1 turns on.

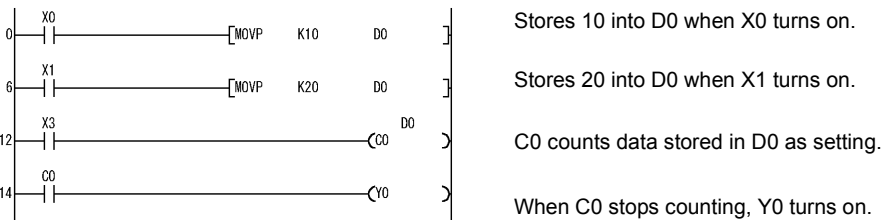

Coding			
0	LD	X0	
1	MOVP	K10	D0
6	LD	X1	
7	MOVP	K20	D0
12	LD	X3	
13	OUT	C0	D0
14	LD	C0	
15	OUT	Y0	
16	END		



### 3.25.5 Output Instructions : Device set, reset ... SET, RST

		Usable Devices									Digit Designation	Error Flag (M9010, M9011)
		Bit devices			Word (16-bit) devices			Constants		Level		
		X	Y	M	T	C	D	K	H	N		
SET	Ⓓ		○	○								
RST			○	○	○	○	○					

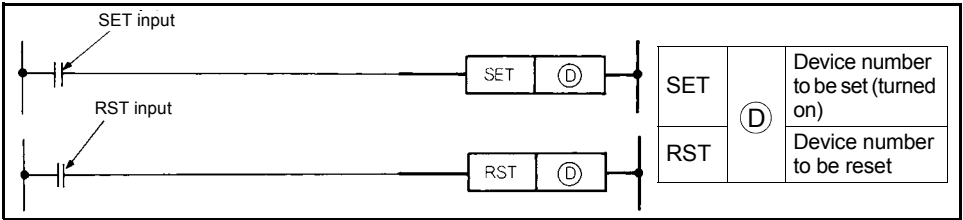

#### Functions

##### SET

- (1) Turns on the specified device when the SET input turns on.
- (2) The device turned on is held on if the SET input turns off. It can be turned off by the RST instruction.

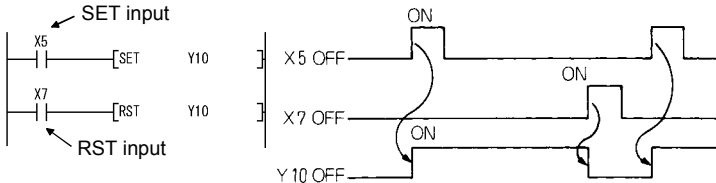

- (3) When the SET input is off, the device status does not change.

##### RST

- (1) When the RST input turns on, the specified device operates as described below.

Device	Status
Y, M	The coil and contact are turned off.
T, C	The present value is reset to 0 and the coil and contact are turned off.
D	Cleared to 0.

- (2) When the RST input is off, the device status does not change.



(3) The function of RST (D) is the same as that of the following ladder.

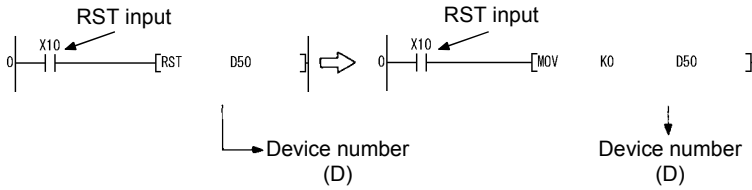

### Execution Conditions

The SET and RST instructions are executed every scan.

#### REMARKS

- Three steps are used when the following device is used.
- SET instruction ... Special relay (M)
- RST instruction ... Special relay (M), all word devices

### Program Examples

SET , RST

1) Program that sets (turns on) Y8 when X8 turns on and resets (turns off) Y8 when X9 turns on.

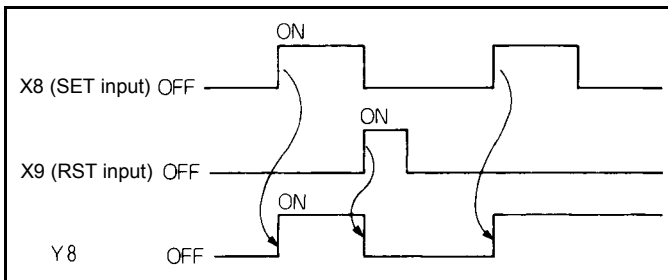
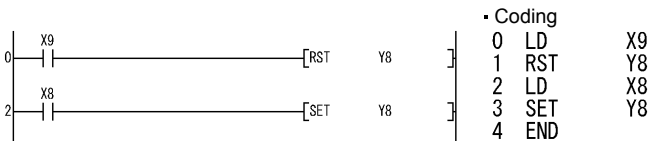

Operations of SET and RST instructions



2) Program that resets the data register contents to 0.

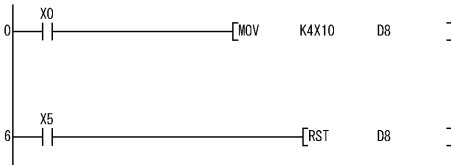

Stores X10 to 1F contents into D8 when X0 turns on.

Resets D8 contents to 0 when X5 turns on.

• Coding

```

0 LD      X0
1 MOV     K4X10  D8
6 LD      X5
7 RST     D8
10 END
    
```

3) Program that resets the 100ms retentive timer and counter.

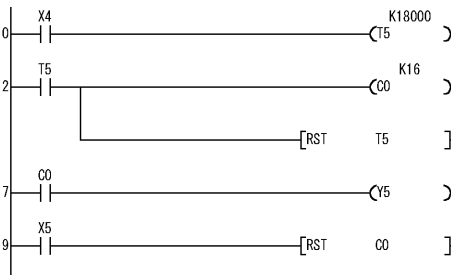

When T5 is set as retentive timer, T5 turns on when ON period of X4 reaches 30 minutes.

Counts the number of times T5 turned on.

Resets T5 when T5 turns on.

When C0 stops counting, Y5 turns on.

When X5 turns on, C0 is reset.

• Coding

```

0 LD      X4
1 OUT     T5      K18000
2 LD      T5
3 OUT     C0      K16
4 RST     T5
7 LD      C0
8 OUT     Y5
9 LD      X5
10 RST    C0
13 END
    
```

### 3.25.6 Output instructions : leading edge, trailing edge differential outputs ... PLS, PLF

	Usable Devices										Digit Designation	Error Flag (M9010, M9011)
	Bit devices			Word (16-bit) devices			Constants		Level			
	X	Y	M	T	C	D	K	H	N			
Ⓓ		○	○									

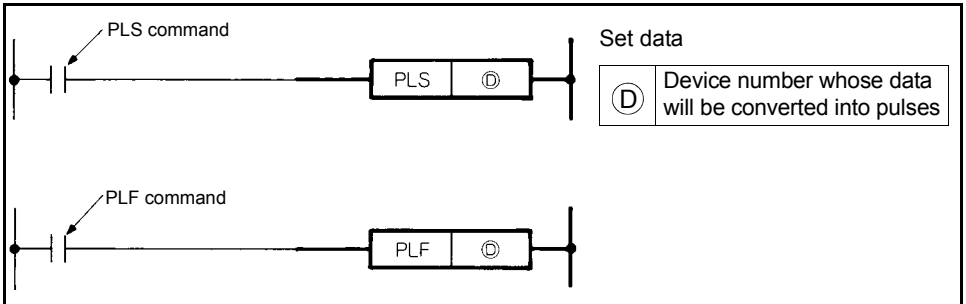

## Functions

### PLS

- Turns the specified device on when the PLS command turns from OFF to ON, and turns it off except when the PLS command turns from OFF to ON.

When there is one PLS instruction for the device specified at Ⓓ during one scan, the specified device turns on for one scan.

Do not execute the PLS instruction for the same device more than once during one scan.

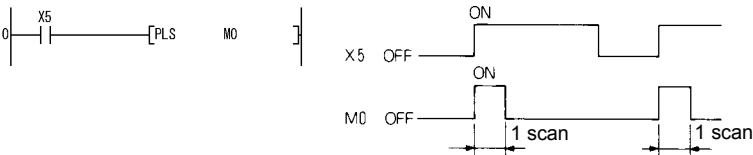

- If the status is switched to STOP and switched to RUN again after execution of the PLS instruction, the PLS instruction is not executed.





**PLF**

- (1) Turns the specified device on one scan when the PLF command turns from ON to OFF, and turns it off except when the PLF turns from ON to OFF.

When there is one PLF instruction for the device specified at (D) during one scan, the specified device turns on for one scan.

Do not execute the PLF instruction for the same device more than once during one scan.

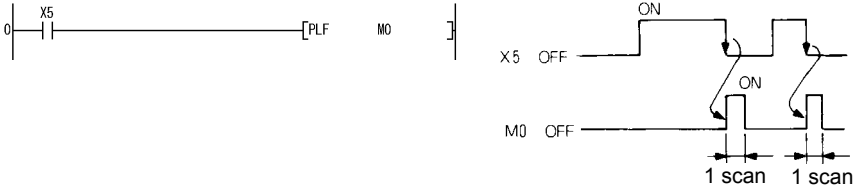

- (2) If the status is switched to STOP and switched to RUN again after execution of the PLF instruction, the PLF instruction is not executed.

**Program Examples**

**PLS**

Program that executes the PLS instruction when X9 turns on.

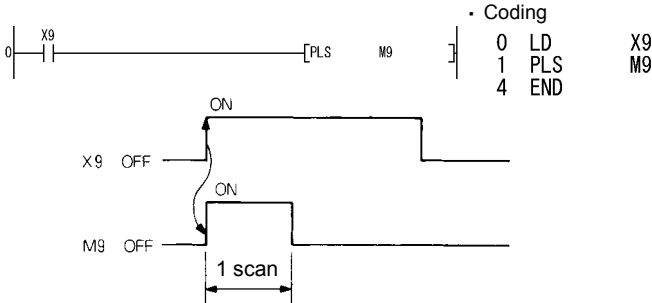

**PLF**

Program that executes the PLF instruction when X9 turns off.

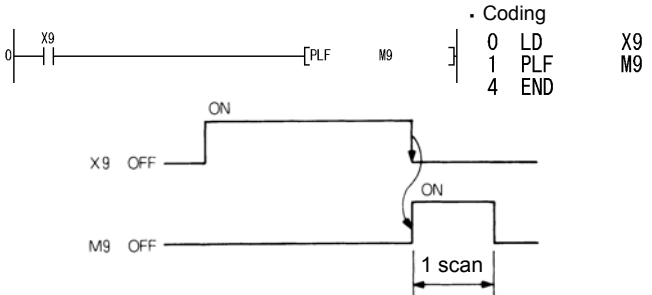

### 3.25.7 Shift Instructions : Bit device shift ... SFT, SFTP

	Usable Devices										Digit Designation	Error Flag (M9010, M9011)
	Bit devices			Word (16-bit) devices			Constants		Level			
	X	Y	M	T	C	D	K	H	N			
Ⓓ		○	○									

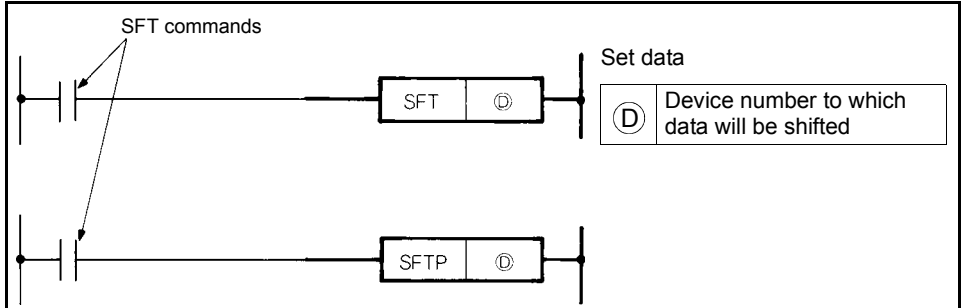

#### Functions

- (1) Shifts the ON/OFF status of the device preceding the one specified at Ⓓ to the specified device, and turns off the preceding device.
- (2) Use the SET instruction to turn on the first device from which data will be shifted.
- (3) When using the SFT or SFTP instructions consecutively, program in order of larger to smaller device numbers.

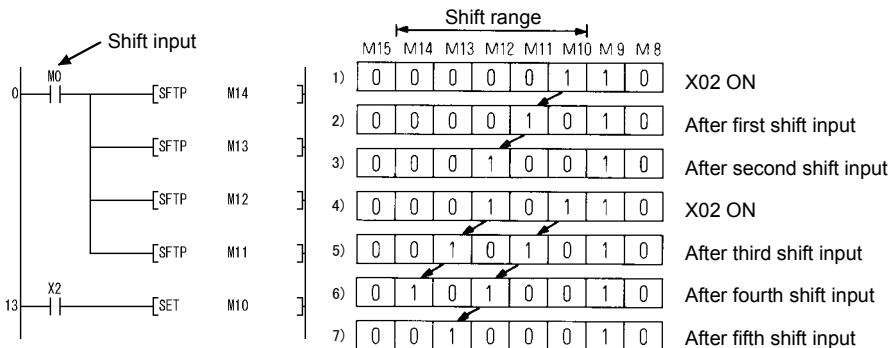

\*At M8 to 15, 1 indicates ON and 0 indicates OFF.



## Program Example

SFT

1) Program that shifts the Y7 - B data when X8 turns on.

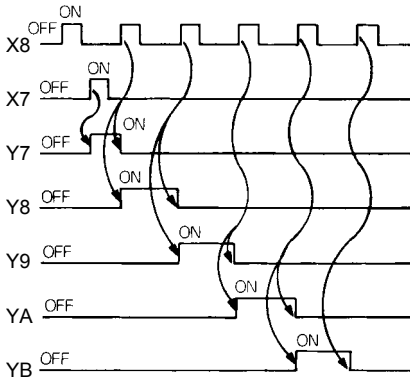
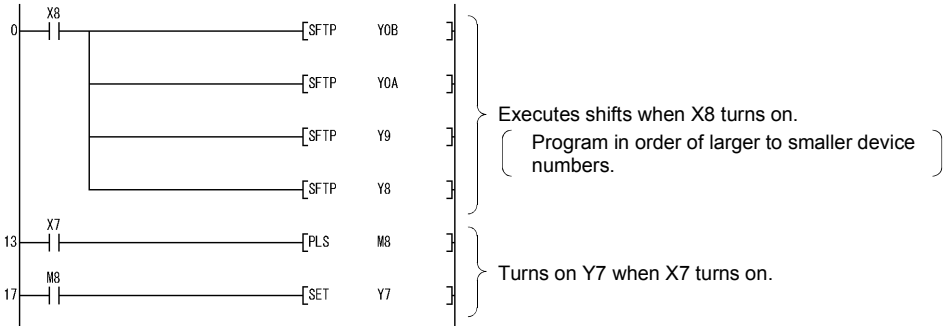

• Coding

0	LD	X8
1	SFTP	Y0B
4	SFTP	Y0A
7	SFTP	Y9
10	SFTP	Y8
13	LD	X7
14	PLS	M8
17	LD	M8
18	SET	Y7
19	END	

### 3.25.8 Master control instructions : master control set, reset ... MC, MCR

	Usable Devices									Digit Designation	Error Flag (M9010, M9011)
	Bit devices			Word (16-bit) devices			Constants		Level		
	X	Y	M	T	C	D	K	H	N		
n										○	
Ⓓ		○	○								

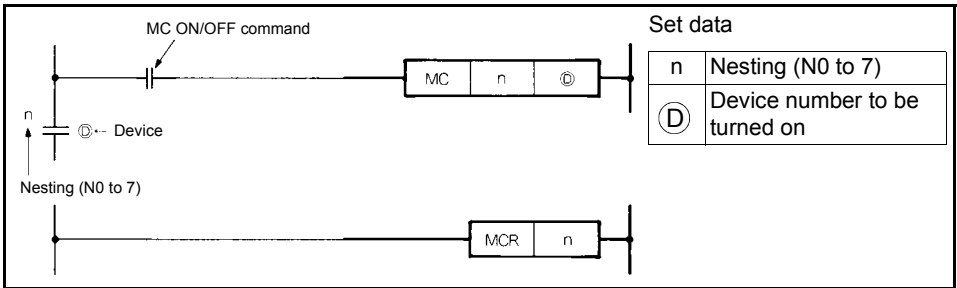

#### Functions

- The master control instructions are designed to create an efficient ladder switching sequence program by switching on/off the common bus of the ladder. The ladder that uses master control is as shown below.

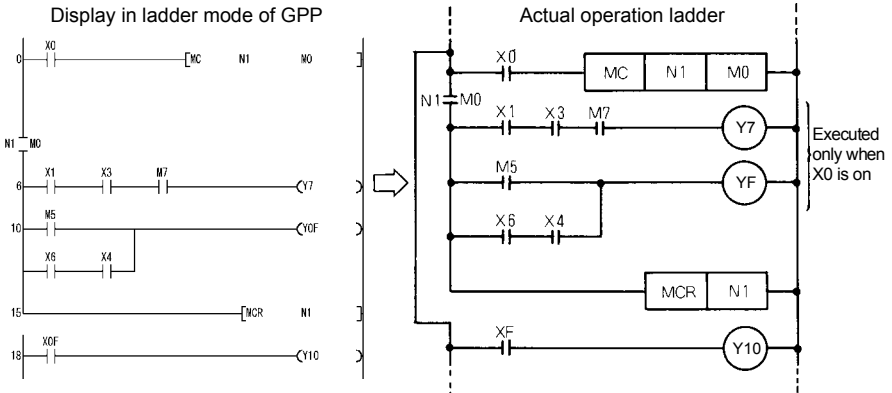



## MC

- (1) When the MC ON/OFF command is on at the start of master control, the operation results between MC and MCR are as performed by the instructions (ladder).
- (2) If the MC instruction is off, the scan between the MC and MCR instructions is executed, and therefore, the scan time does not become short.  
When the MC instruction is off, the operation results between MC and MCR are as described below.

100ms, 10ms timer	The count value is reset to 0 and both the coil and contact turn off.
100ms retentive timer, counter	The coil turns off but both the count value and contact maintain the current states.
Devices in OUT instruction	All turn off.
Device is executing SET, RST, SFT or basic or application instruction	Maintains the current state.

- (3) By changing the device at (D), the MC instruction can use the same nesting (N) number any number of times.
- (4) When the MC instruction is on, the coil of the device specified at (D) turns on. Since using the same device in the OUT instruction, etc. will result in double coils, the device specified at (D) should not be used in any other instruction.



**MCR**

(1) This instruction is designed to reset the master control and indicates the end of the master control range.

(2) Do not provide a contact instruction in front of the MCR instruction.

The master control instructions can be nested. Their master control ranges are differentiated by the nesting (N). The nesting can be used from N0 to N7.

Using the nesting structure, you can create a ladder that restricts the program execution conditions in order.

The ladder using the nesting structure is as shown below.

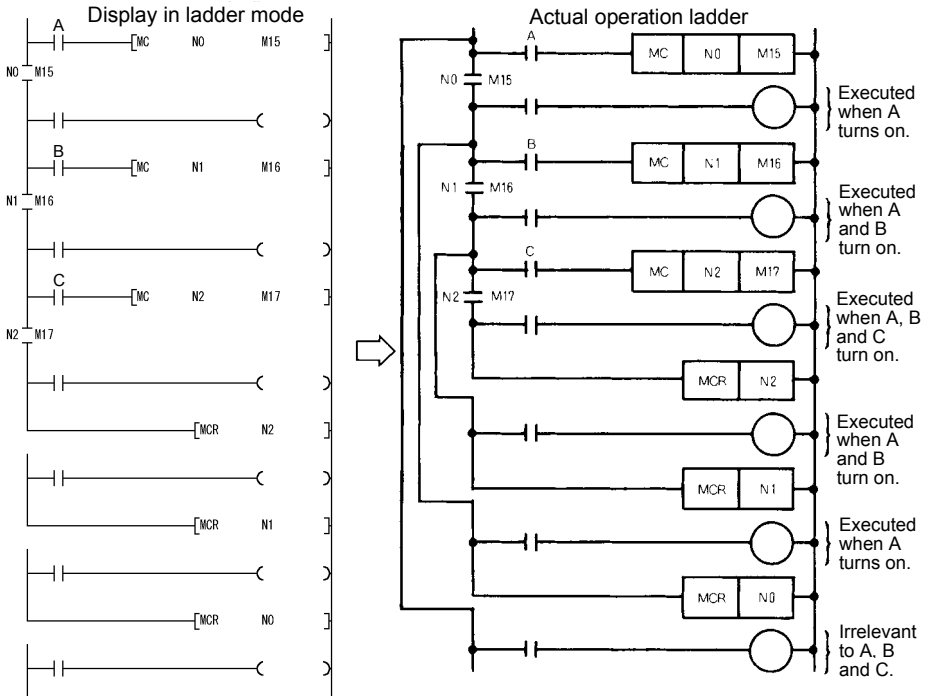



Note the following when nesting the instructions.

- (1) The instructions can be nested to a level of eight (N0 to 7). When nesting them, use MC from lower to higher nesting (N) numbers and MCR from higher to lower numbers. In the opposite order, the PLC function cannot perform normal operation since the instructions cannot be nested.

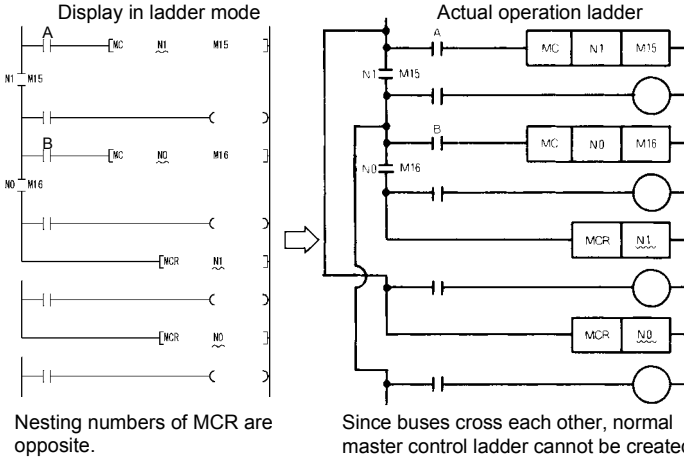

- (2) When the MCR instructions are gathered in one place in the nesting structure, all master controls can be terminated by one lowest nesting (N) number.

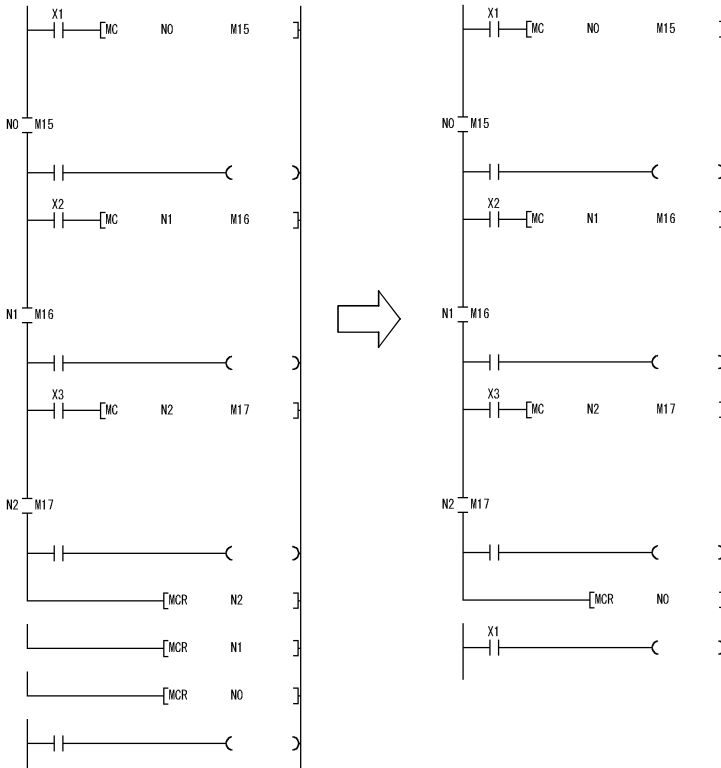

### 3.25.9 End Instruction : Sequence program end ... END

Usable Devices									Digit Designation	Error Flag (M9010, M9011)
Bit devices			Word (16-bit) devices			Constants		Level		
X	Y	M	T	C	D	K	H	N		

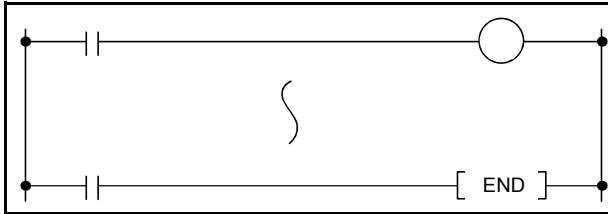

#### Functions

- (1) Indicates the end of a program. Execution terminates scanning at this step and returns to step 0.

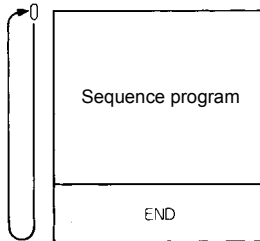

- (2) The END instruction cannot be used halfway through the sequence program.

#### CAUTION

If the END instruction does not exist in the program, an operation error occurs and the PLC function does not operate.





### 3.25.10 Other Instructions : No operation ... NOP

Usable Devices									Digit Designation	Error Flag (M9010, M9011)
Bit devices			Word (16-bit) devices			Constants		Level		
X	Y	M	T	C	D	K	H	N		
										○

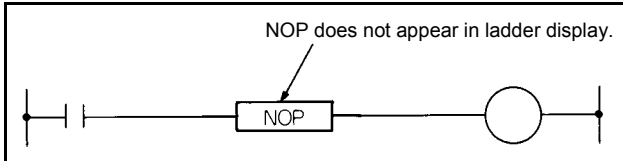

#### Functions

##### NOP

- (1) No-operation instruction that has no influence on the preceding operation.
- (2) Use NOP to:
  - 1) Provide space for debugging of a sequence program.
  - 2) Delete an instruction without changing the number of steps. (Change the instruction for NOP)
  - 3) Delete an instruction temporarily.



### Program Examples

#### NOP

#### 1) Contact short-circuit (AND, ANI)

Before change

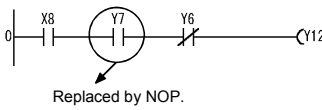

After change

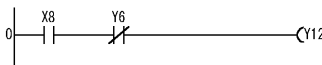

- Coding

```

0 LD      X8
1 AND    Y7
2 ANI    Y6
3 OUT    Y12
4 END

```

- Coding

```

0 LD      X8
1 NOP
2 ANI    Y6
3 OUT    Y12
4 END

```

#### 2) Contact short-circuit (LD, LDI).....Note that if LD or LDI is replaced by NOP, the ladder will be completely changed.

Before change

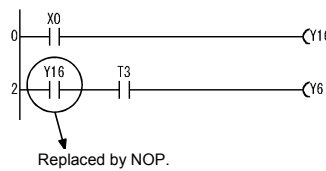

After change

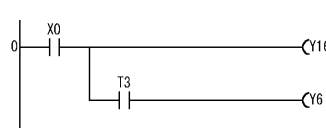

- Coding

```

0 LD      X0
1 OUT    Y16
2 LD      Y16
3 AND    T3
4 OUT    Y6
5 END

```

```

0 LD      X0
1 OUT    Y16
2 NOP
3 AND    T3
4 OUT    Y6
5 END

```

Before change

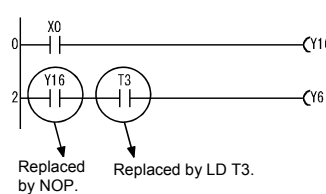

After change

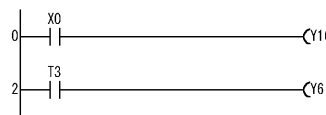

- Coding

```

0 LD      X0
1 OUT    Y16
2 LD      Y16
3 AND    T3
4 OUT    Y6
5 END

```

```

0 LD      X0
1 OUT    Y16
2 NOP
3 LD      T3
4 OUT    Y6
5 END

```



## 3.26 Basic instructions (16-bit)

The basic instructions (16-bit) can handle numerical data represented in 16-bit.

### 3.26.1 Comparison Operation Instructions

- (1) The comparison operation instruction is handled as a contact, compares the magnitudes of two pieces of data (e.g. =, >, <), and turns on when the condition holds.
- (2) Use the comparison operation instructions in the same manner as the contact instructions of the PLC instructions as indicated below.
  - LD, LDI ..... LD=
  - AND, ANI ..... AND=
  - OR, ORI ..... OR=
- (3) There are the following 18 different comparison operation instructions.  
 Refer to page 150 for details.

Classification	Instruction Symbol	Classification	Instruction Symbol	Classification	Instruction Symbol
=	LD=	>	LD>	<	LD<
	AND=		AND>		AND<
	OR=		OR>		OR<
≠	LD<>	≤	LD≤	≥	LD≥
	AND<>		AND≤		AND≥
	OR<>		OR≤		OR≥

- (4) The conditions that the comparison operation instructions turn on are as follows.

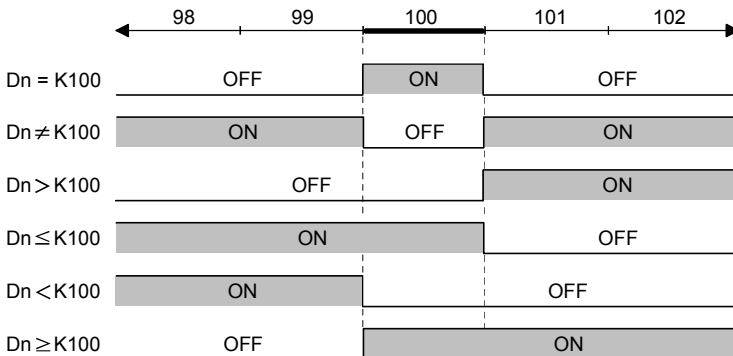



---

---

**CAUTION**

---

---

The comparison instruction regards the specified data as BIN values. Hence, if the value whose most significant bit (b15) is 1 (8 to F) is specified for comparison of hexadecimal data, it is regarded as a negative BIN value.

**Example**

**Comparison of 4-digit HEX values**

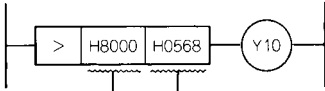

Regarded as -32767 in BIN.      Regarded as 1384 in BIN.

**Therefore, the result is -32767 < 1384 and Y10 does not turn on.**

---

---



### 3.26.2 Comparison Operation Instructions : 16-bit data comparison ... =, <>, >, <=, <, >=

	Usable Devices									Digit Designation	Error Flag (M9010, M9011)
	Bit devices			Word (16-bit) devices			Constants		Level		
	X	Y	M	T	C	D	K	H	N		
S1	○	○	○	○	○	○	○	○		K1 to K4	○
S2	○	○	○	○	○	○	○	○			

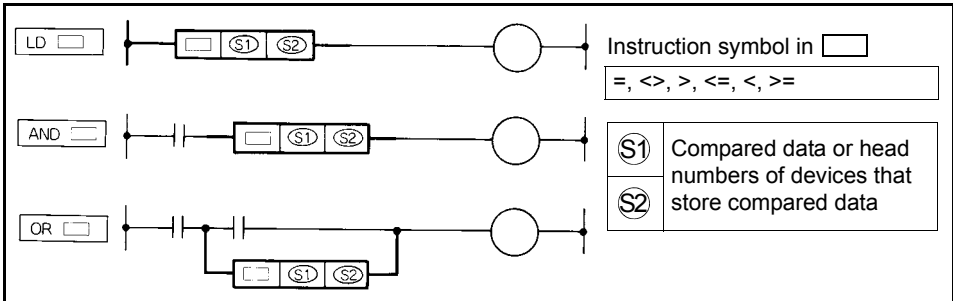

### Functions

- (1) Handled as an N/O contact and performs 16-bit comparison operation.
- (2) The comparison operation results are as indicated below.

Instruction symbol in <input type="text"/>	Condition	Comparison Operation Result	Instruction symbol in <input type="text"/>	Condition	Comparison Operation Result												
=	S1 = S2	Energize	=	S1 ≠ S2	Not energize												
<>	S1 ≠ S2		>	S1 > S2		<=	S1 ≤ S2	<	S1 < S2	>=	S1 ≥ S2						
>	S1 > S2		<=	S1 ≤ S2		<	S1 < S2	>=	S1 ≥ S2								
<=	S1 ≤ S2		<	S1 < S2		>=	S1 ≥ S2										
<	S1 < S2		>=	S1 ≥ S2													
>=	S1 ≥ S2																

### Execution Conditions

The execution conditions of LD , AND  and OR  are as indicated below.

Instruction	Execution Condition
LD <input type="text"/>	Executed every scan.
AND <input type="text"/>	Executed only when the preceding contact instruction is on.
OR <input type="text"/>	Executed every scan.



**REMARKS**

Seven steps are used when:

- The digit designation of a bit device is not K4.
- The beginning of a bit device is not a multiple of 8.

**Program Examples**

=

1) Program that compares the X0-F data and D3 data.

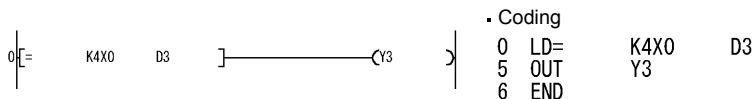

<>

2) Program that compares the BCD value 100 and D3 data.

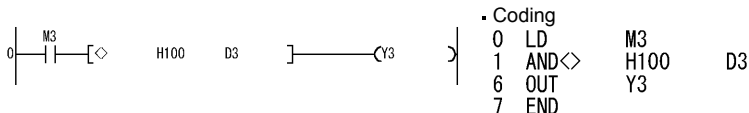

>

3) Program that compares the BIN value 100 and D3 data.

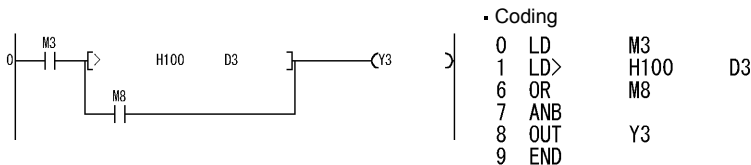

<=

4) Program that compares the D0 and D3 data.

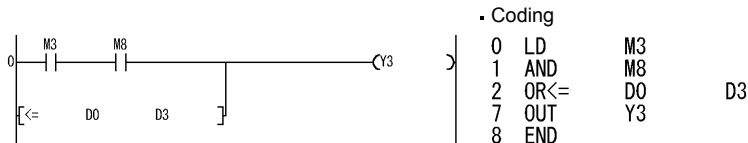



### 3.26.3 Arithmetic Operation Instructions

The arithmetic operation instructions are instructions which perform the addition, subtraction, multiplication, and division of two BIN data.

(1) Arithmetic operation with BIN (Binary)

- If the operation result of an addition instruction exceeds 32767 , the result becomes a negative value.
- If the operation result of a subtraction instruction is less than - 32768 , the result becomes a positive value.
- The operation of a positive value and a negative value is as follows:

$$5 + 8 \rightarrow 13$$

$$5 - 8 \rightarrow -3$$

$$5 \times 3 \rightarrow 15$$

$$-5 \times 3 \rightarrow -15$$

$$-5 \times (-3) \rightarrow 15$$

$$-5 / 3 \rightarrow -1 \text{ and remainder } -2$$

$$5 / (-3) \rightarrow -1 \text{ and remainder } 2$$

$$-5 / (-3) \rightarrow 1 \text{ and remainder } -2$$

### 3.26.4 Arithmetic Operation Instructions : BIN 16-bit addition, subtraction ... +, +P, -, -P

	Usable Devices									Digit Designation	Error Flag
	Bit devices			Word (16-bit) devices			Constants		Level		
	X	Y	M	T	C	D	K	H	N		
(S)	○	○	○	○	○	○	○	○		K1 to K4	○
(D)		○	○	○	○	○					
(S1)	○	○	○	○	○	○	○	○			
(S2)	○	○	○	○	○	○	○	○			
(D1)		○	○	○	○	○					

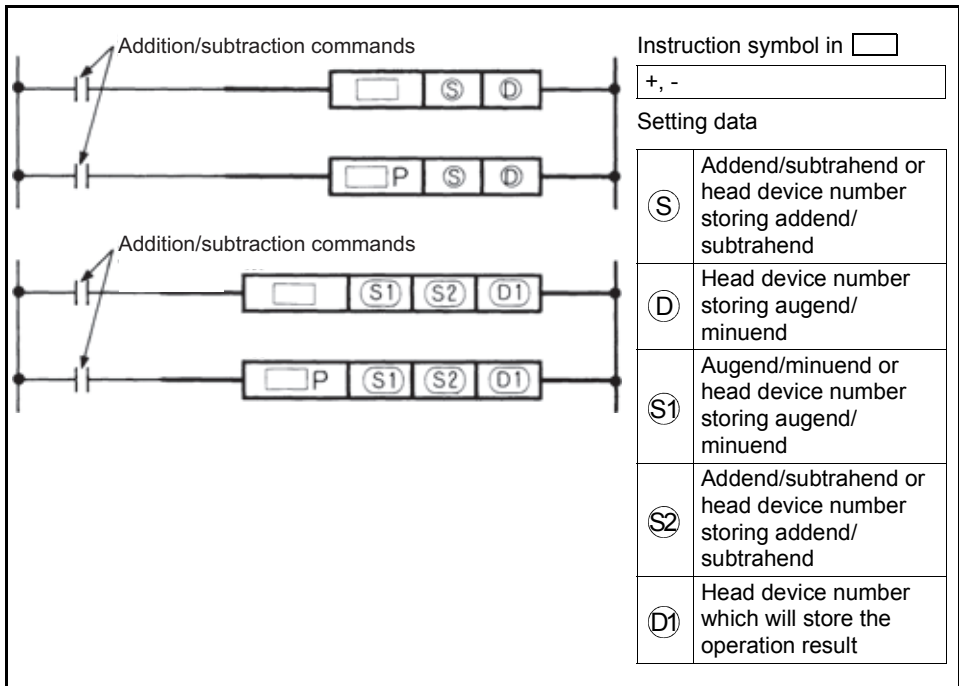





## Functions

+
---

- (1) Performs the addition of BIN data specifies at  $\textcircled{D}$  and the BIN data specified at  $\textcircled{S}$ , and stores the addition result into the device specified at  $\textcircled{D}$ .

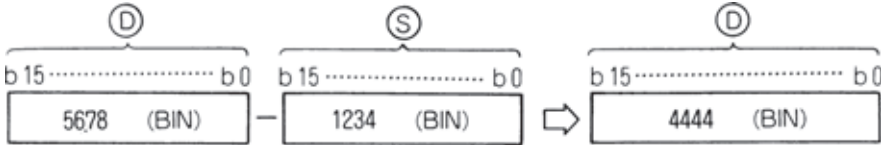

- (2) Performs the addition of BIN data specified at  $\textcircled{S1}$  and the BIN data specified at  $\textcircled{S2}$ , and stores the addition result into the device specified at  $\textcircled{D1}$ .

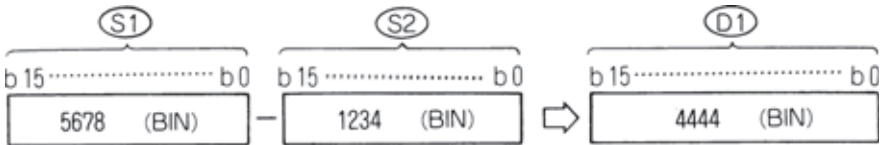

- (3) At  $\textcircled{S}$ ,  $\textcircled{S1}$ ,  $\textcircled{S2}$  and  $\textcircled{D}$ , -32768 to 32767 (BIN 16 bits) can be specified.
- (4) The judgment of whether the data of  $\textcircled{S}$ ,  $\textcircled{S1}$ ,  $\textcircled{S2}$  and  $\textcircled{D}$  are positive or negative is made at the highest bit (b15).  
 0 ..... Positive  
 1 ..... Negative
- (5) When the 0th bit has underflown, the carry flag does not turn on.  
 When the 15th bit has overflown, the carry flag does not turn on.  
 (carry flag is not available)

## Functions

-

- (1) Performs the subtraction of BIN data specifies at  $\textcircled{D}$  and the BIN data specified at  $\textcircled{S}$ , and stores the subtraction result into the device specified at  $\textcircled{D}$ .



- (2) Performs the subtraction of BIN data specified at  $\textcircled{S1}$  and the BIN data specified at  $\textcircled{S2}$ , and stores the subtraction result into the device specified at  $\textcircled{D1}$ .



- (3) At  $\textcircled{S}$ ,  $\textcircled{S1}$ ,  $\textcircled{S2}$  and  $\textcircled{D}$ , -32768 to 32767 (BIN 16 bits) can be specified.
- (4) The judgment of whether the data of  $\textcircled{S}$ ,  $\textcircled{S1}$ ,  $\textcircled{S2}$  and  $\textcircled{D}$  are positive or negative is made at the highest bit (b15).  
 0 ..... Positive  
 1 ..... Negative
- (5) When the 0th bit has underflown, the carry flag does not turn on.  
 When the 15th bit has overflown, the carry flag does not turn on.  
 (carry flag is not available)



## Execution Conditions

Addition/subtraction command.

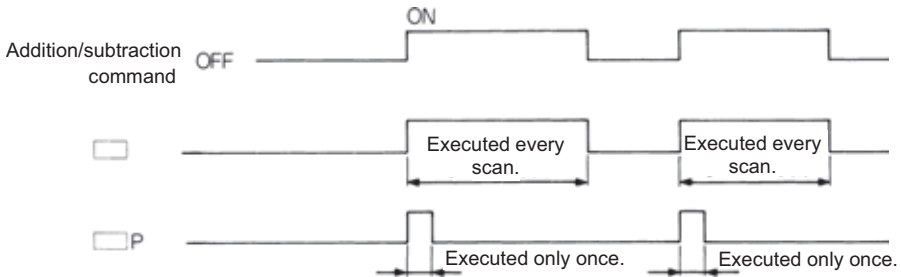

## Program Examples

+

Program which adds the content of A0 to the content of D3 and outputs the result to Y38 to 3F when X5 turns on.



• Coding  
 0 LD X005  
 1 +P D3 A0 K2Y038  
 8 END

-

Program which outputs the difference between the set value and present value timer T3 to Y40 to 53 in BCD.

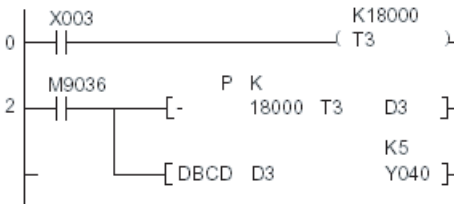

• Coding  
 0 LD X003  
 1 OUT T3 K18000  
 2 LD M9036  
 3 -P K18000 T3 D3  
 10 DBCD D3 K5Y040  
 19 END

### 3.26.5 Arithmetic operation instructions : BIN 16-bit multiplication, division ... \*, \*P, /, /P

	Usable Devices									Digit Designation	Error Flag
	Bit devices			Word (16-bit) devices			Constants		Level		
	X	Y	M	T	C	D	K	H	N		(M9010, M9011)
Ⓢ1	○	○	○	○	○	○	○	○		K1 to K4	○
Ⓢ2	○	○	○	○	○	○	○	○			
Ⓓ		○	○	○	○	○					

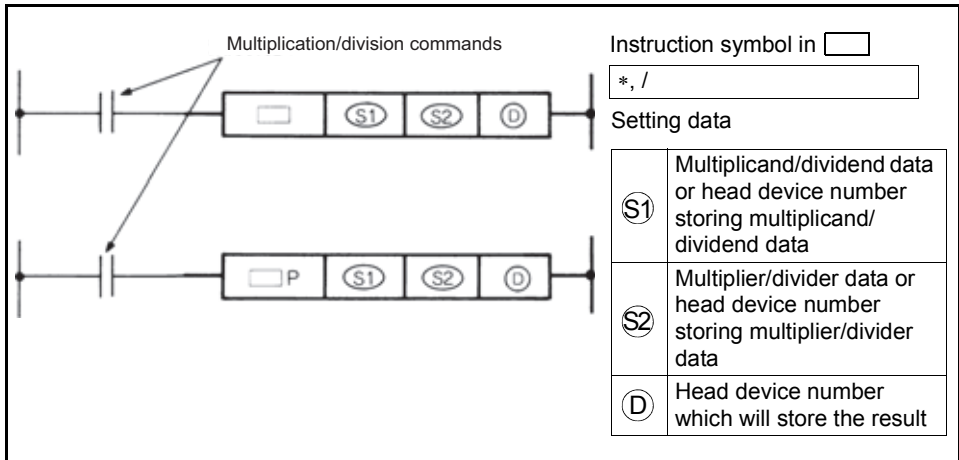



## Functions

\*

- (1) Performs the multiplication of BIN data specified at  $\textcircled{S1}$  and the BIN data specified at  $\textcircled{S2}$ , and stores the multiplication result into the device specified at  $\textcircled{D}$ .

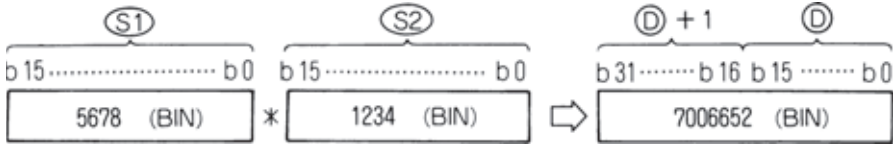

- (2) When  $\textcircled{D}$  is a bit device, specify the bits, beginning with the lower bits.

Example

K1: Lower 4 bits (b0 to 3)

K4: Lower 16 bits (b0 to 15)

- (3) At  $\textcircled{S1}$  and  $\textcircled{S2}$ , -32768 to 32767 (BIN 16 bits) can be specified.
- (4) The judgment of whether the data of  $\textcircled{S1}$  and  $\textcircled{S2}$  are positive or negative is made at the highest bit (b15) and that of  $\textcircled{D}$ , at (b31).
- 0 ..... Positive  
 1 ..... Negative

/

- (1) Performs the division of BIN data specified at (S1) and the BIN data specified at (S2), and stores the result into the device specified at (D).

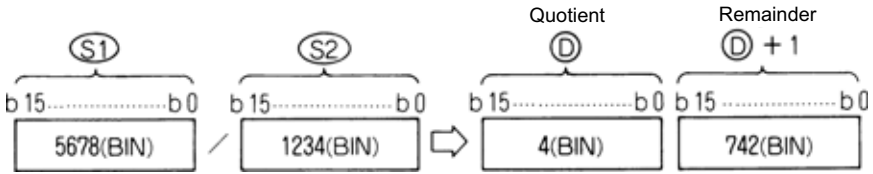

- (2) In regards to the operation result, the quotient and remainder are stored by use of 32 bits in the case of word device, and only the quotient is stored by use of 16 bits in the case of bit device.

Quotient : Stored to the lower 16 bits.

Remainder : Stored to the upper 16 bits. (Storable only in the case of word device)

- (3) At (S1) and (S2), -32768 to 32767 (BIN 16 bits) can be specified.
- (4) The judgment of whether the data of (S1), (S2), (D) and (D)+1 are positive or negative is made at the highest bit (b15).  
(Both quotient and remainder have sign.)  
0 ..... Positive  
1 ..... Negative

### Execution Conditions

The execution conditions of the transfer instructions are as shown below.

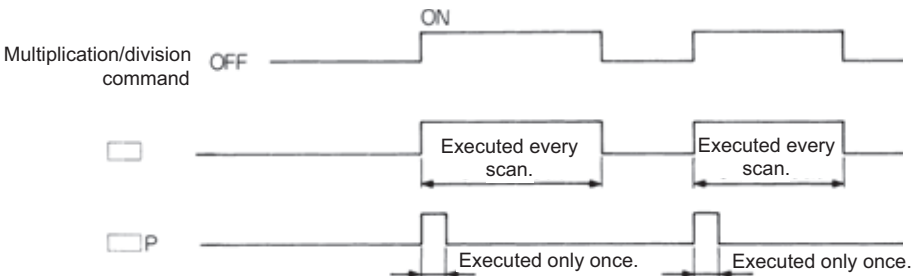



## Operation Errors

In the following case, operation error occurs and the error flag turns on.

- A1 or V has been specified at (D).
- The divisor (S2) is 0.

## Program Examples

\*

1) Program which stores the multiplication result of 5678 and 1234 in BIN to D3 and 4 when X5 turns on.

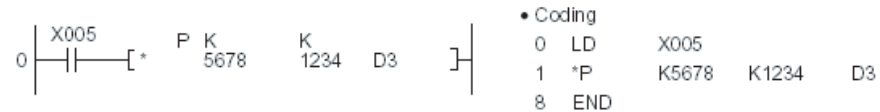

2) Program which outputs the multiplication result of the BIN data of X8 to F and the BIN data of X10 to 1B to Y30 to 3F.

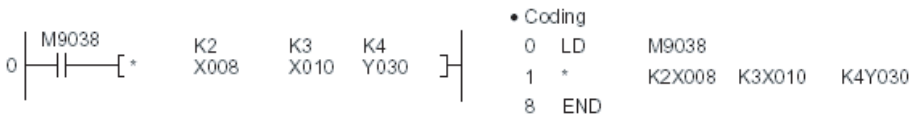

/

Program which outputs the quotient, obtained by dividing the data of X8 to F by 3.14, to Y30 to 3F when X3 turns on.

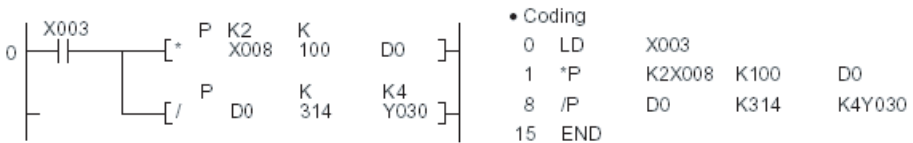

### 3.26.6 Data transfer instructions

The data transfer instructions are designed to transfer data.

The data moved by the data transfer instruction is maintained until new data is transferred.

### 3.26.7 Data transfer instructions : 16-bit data transfer ... MOV, MOVP

		Usable Devices									Digit Designation	Error Flag
		Bit devices			Word (16-bit) devices			Constants		Level		(M9010, M9011)
		X	Y	M	T	C	D	K	H	N		
MOV, MOVP	Ⓢ	○	○	○	○	○	○	○	○		K1 to K4	○
	Ⓓ		○	○	○	○	○					

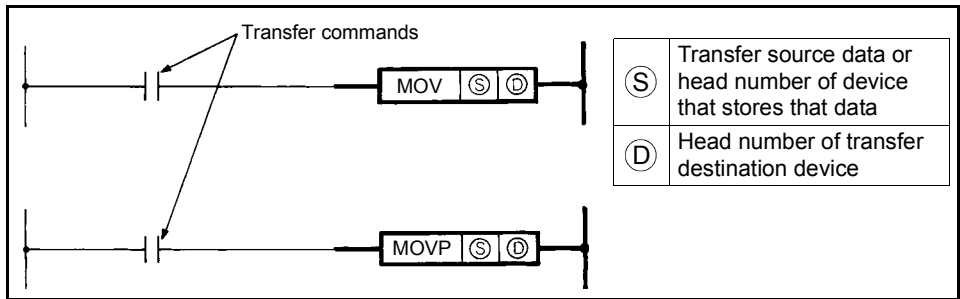

### Functions

MOV

Transfers the 16-bit data of the device specified at Ⓢ to the device specified at Ⓓ.

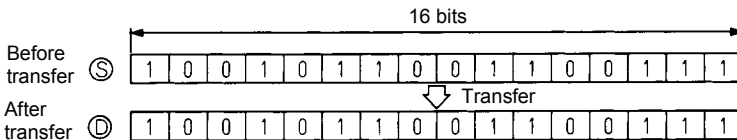

### Execution Conditions

The execution conditions of the transfer instructions are as shown below.



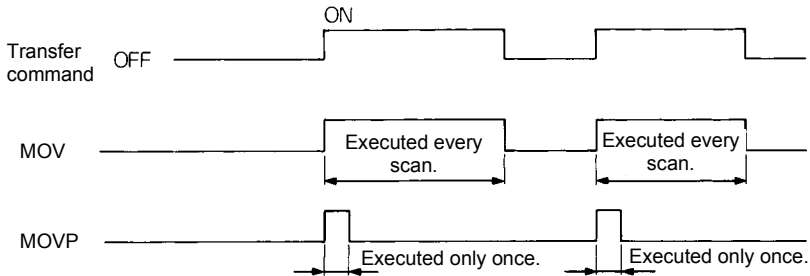

## Program Examples

### MOV

1) Program that stores the input X0-B data into D8.



2) Program that stores 155 into D8 in binary when X8 turns on.

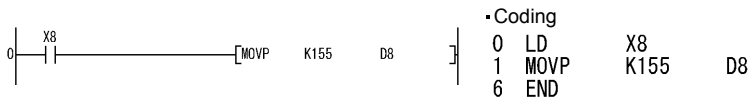

## 3.27 Basic instructions (32-bit)

The basic instructions (32-bit) can handle numerical data represented in 32-bit.

### 3.27.1 Comparison Operation Instructions

- (1) The comparison operation instruction is handled as a contact, compares the magnitudes of two pieces of data (e.g. D=, D>, D<), and turns on when the condition holds.
- (2) Use the comparison operation instructions in the same manner as the contact instructions of the PLC instructions as indicated below.
  - LD, LDI.....LDD=
  - AND, ANI .....ANDD=
  - OR, ORI .....ORD=
- (3) There are the following 18 different comparison operation instructions.  
*Refer to page 165 for details.*

Classification	Instruction Symbol	Classification	Instruction Symbol	Classification	Instruction Symbol
=	LDD=	>	LDD>	<	LDD<
	ANDD=		ANDD>		ANDD<
	ORD=		ORD>		ORD<
≠	LDD<>	≤	LDD≤=	≥	LDD≥=
	ANDD<>		ANDD≤=		ANDD≥=
	ORD<>		ORD≤=		ORD≥=

- (4) The conditions that the comparison operation instructions turn on are as follows.

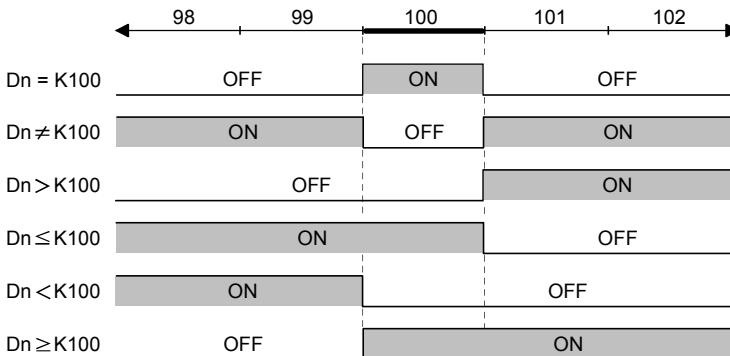





---

**CAUTION**

---

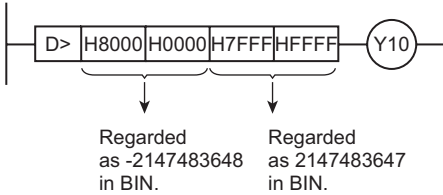
The comparison instruction regards the specified data as BIN values. Hence, if the value whose most significant bit (b31) is 1 (8 to F) is specified for comparison of hexadecimal data, it is regarded as a negative BIN value.

**Example**
**Comparison of 8-digit HEX values**

**Therefore, the result is -2147483648 < 2147483647 and Y10 does not turn on.**

---

### 3.27.2 Comparison Operation Instructions : 32-bit data comparison ... D=, D<>, D>, D<=, D<, D>=

	Usable Devices									Digit Designation	Error Flag (M9010, M9011)
	Bit devices			Word (16-bit) devices			Constants		Level		
	X	Y	M	T	C	D	K	H	N		
(S1)	○	○	○	○	○	○	○	○		K1 to K8	○
(S2)	○	○	○	○	○	○	○	○			

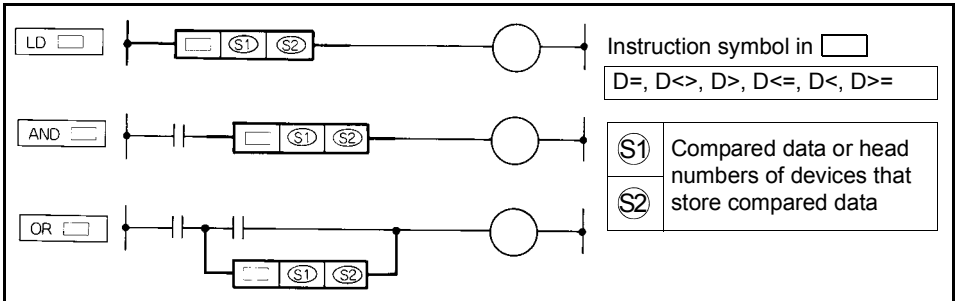

#### Functions

- Handled as an N/O contact and performs 32-bit comparison operation.
- The comparison operation results are as indicated below.

Instruction symbol in [ ]	Condition	Comparison Operation Result	Instruction symbol in [ ]	Condition	Comparison Operation Result
D=	(S1) = (S2)	Energize	D=	(S1) ≠ (S2)	Not energize
D<>	(S1) ≠ (S2)		D<>	(S1) = (S2)	
D>	(S1) > (S2)		D>	(S1) ≤ (S2)	
D<=	(S1) ≤ (S2)		D<=	(S1) > (S2)	
D<	(S1) < (S2)		D<	(S1) ≥ (S2)	
D>=	(S1) ≥ (S2)		D>=	(S1) < (S2)	

#### Execution Conditions

The execution conditions of LD [ ], AND [ ] and OR [ ] are as indicated below.

Instruction	Execution Condition
LD [ ]	Executed every scan.
AND [ ]	Executed only when the preceding contact instruction is on.
OR [ ]	Executed every scan.



**REMARKS**

Seven steps are used when:

- The digit designation of a bit device is not K8.
- The beginning of a bit device is not a multiple of 8.

**Program Examples**

D=

1) Program that compares the M0 to M31 data with D3 and D4 data.

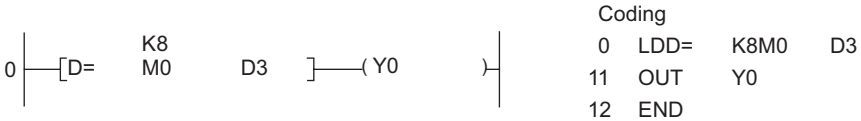

D<>

2) Program that compares the BCD value 18000 with D3 and D4 data.

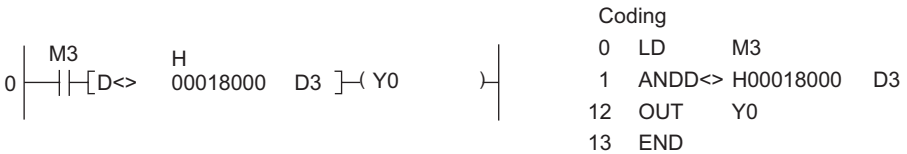

D>

3) Program that compares the BIN value -80000 with D3 and D4 data.

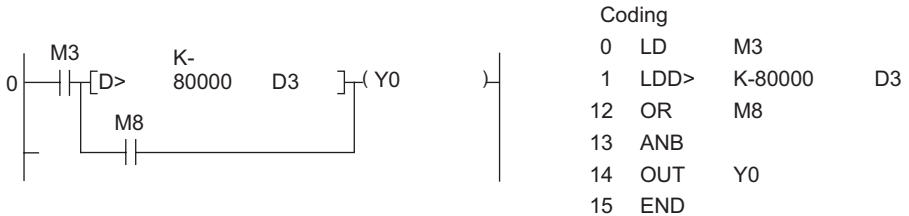

D<=

4) Program that compares the D0 and D1 with D3 and D4 data.

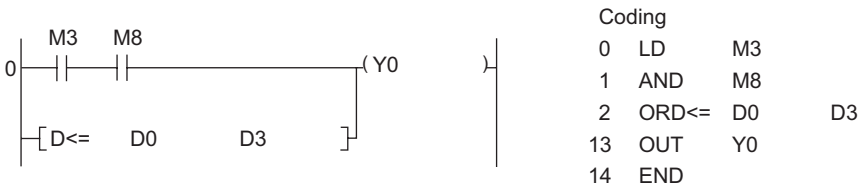

### 3.27.3 Arithmetic Operation Instructions

The arithmetic operation instructions are instructions which perform the addition, subtraction, multiplication, and division of two BIN data.

(1) Arithmetic operation with BIN (Binary)

- If the operation result of an addition instruction exceeds 2147483647 , the result becomes a negative value.
- If the operation result of a subtraction instruction is less than -2147483648 , the result becomes a positive value.
- The operation of a positive value and a negative value is as follows:

$$5 + 8 \rightarrow 13$$

$$5 - 8 \rightarrow -3$$

$$5 \times 3 \rightarrow 15$$

$$-5 \times 3 \rightarrow -15$$

$$-5 \times (-3) \rightarrow 15$$

$$-5 / 3 \rightarrow -1 \text{ and remainder } -2$$

$$5 / (-3) \rightarrow -1 \text{ and remainder } 2$$

$$-5 / (-3) \rightarrow 1 \text{ and remainder } -2$$



### 3.27.4 Arithmetic Operation Instructions : BIN 32-bit addition, subtraction ... D+, D+P, D-, D-P

	Usable Devices									Digit Designation	Error Flag
	Bit devices			Word (16-bit) devices			Constants		Level		(M9010, M9011)
	X	Y	M	T	C	D	K	H	N		
Ⓢ	○	○	○	○	○	○	○	○		K1 to K8	○
Ⓓ		○	○	○	○	○					
Ⓢ1	○	○	○	○	○	○	○	○			
Ⓢ2	○	○	○	○	○	○	○	○			
Ⓓ1		○	○	○	○	○					

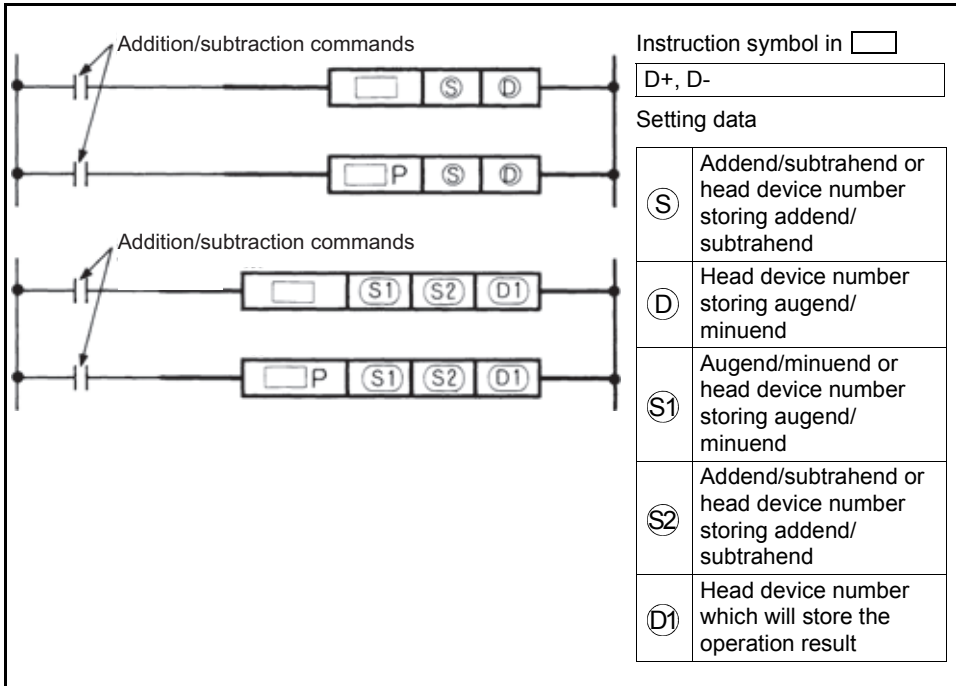

## Functions

D+
----

- (1) Performs the addition of BIN data specified at  $\textcircled{D}$  and the BIN data specified at  $\textcircled{S}$ , and stores the addition result into the device specified at  $\textcircled{D}$ .

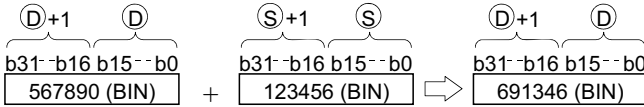

- (2) Performs the addition of BIN data specified at  $\textcircled{S1}$  and the BIN data specified at  $\textcircled{S2}$ , and stores the addition result into the device specified at  $\textcircled{D1}$ .

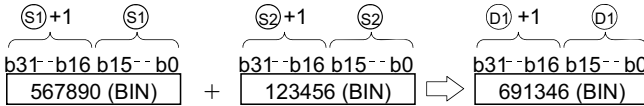

- (3) At  $\textcircled{S}$ ,  $\textcircled{S1}$ ,  $\textcircled{S2}$  and  $\textcircled{D}$ , -2147483648 to 2147483647 (BIN 32 bits) can be specified.
- (4) Whether the data of  $\textcircled{S}$ ,  $\textcircled{S1}$ ,  $\textcircled{S2}$  and  $\textcircled{D}$  are positive or negative is indicated at the highest bit (b31).  
 0 ..... Positive  
 1 ..... Negative
- (5) When the 0th bit has underflown, the carry flag does not turn on.  
 When the 31st bit has overflown, the carry flag does not turn on.  
 (carry flag is not available)





## Functions

D-

- (1) Performs the subtraction of BIN data specifies at  $\textcircled{D}$  and the BIN data specified at  $\textcircled{S}$ , and stores the subtraction result into the device specified at  $\textcircled{D}$ .

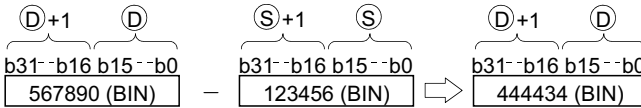

- (2) Performs the subtraction of BIN data specified at  $\textcircled{S1}$  and the BIN data specified at  $\textcircled{S2}$ , and stores the subtraction result into the device specified at  $\textcircled{D1}$ .

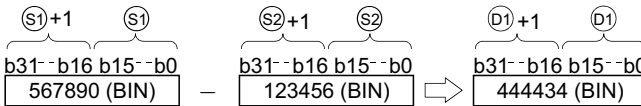

- (3) At  $\textcircled{S}$ ,  $\textcircled{S1}$ ,  $\textcircled{S2}$  and  $\textcircled{D}$ , -2147483648 to 2147483647 (BIN 32 bits) can be specified.
- (4) Whether the data of  $\textcircled{S}$ ,  $\textcircled{S1}$ ,  $\textcircled{S2}$  and  $\textcircled{D}$  are positive or negative is indicated at the highest bit (b31).  
 0 ..... Positive  
 1 ..... Negative
- (5) When the 0th bit has underflow, the carry flag does not turn on.  
 When the 31st bit has overflow, the carry flag does not turn on.  
 (carry flag is not available)





### 3.27.5 Arithmetic operation instructions : BIN 32-bit multiplication, division ... D\*, D\*P, D/, D/P

	Usable Devices									Digit Designation	Error Flag
	Bit devices			Word (16-bit) devices			Constants		Level		(M9010, M9011)
	X	Y	M	T	C	D	K	H	N		
Ⓢ1	○	○	○	○	○	○	○	○		K1 to K8	○
Ⓢ2	○	○	○	○	○	○	○	○			
Ⓓ		○	○	○	○	○					

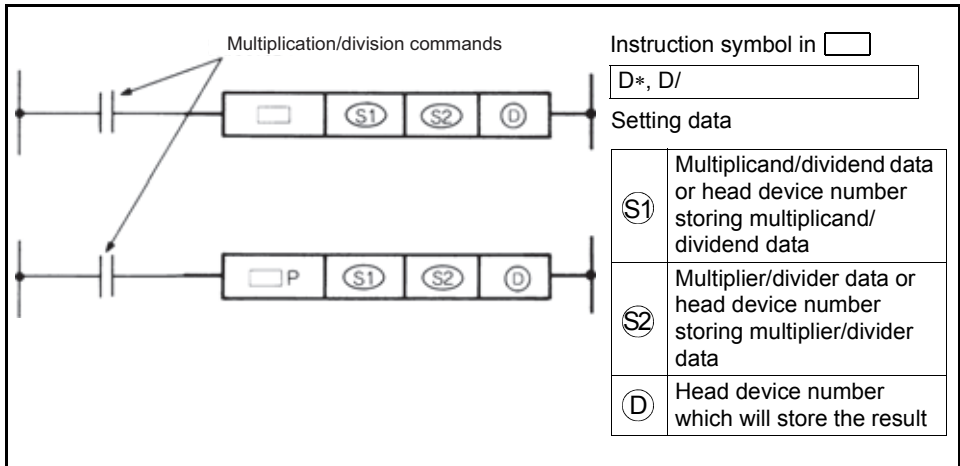

## Functions

D*
----

- (1) Performs the multiplication of BIN data specified at  $\textcircled{S1}$  and the BIN data specified at  $\textcircled{S2}$ , and stores the multiplication result into the device specified at  $\textcircled{D}$ .

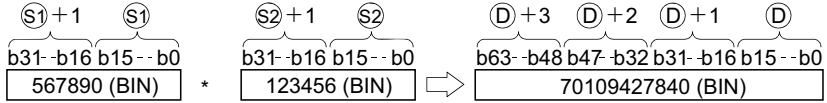

- (2) When  $\textcircled{D}$  is a bit device, specify the bits, beginning with the lower bits.

Example

K1: Lower 4 bits (b0 to 3)

K4: Lower 16 bits (b0 to 15)

K8: Lower 32 bits (b0 to 31)

- (3) At  $\textcircled{S1}$  and  $\textcircled{S2}$ , -2147483648 to 2147483647 (BIN 32 bits) can be specified.
- (4) Whether the data of  $\textcircled{S1}$  and  $\textcircled{S2}$  are positive or negative is indicated at the highest bit (b31) and that of  $\textcircled{D}$ , at (b63).
- 0 ..... Positive  
1 ..... Negative



D/

- (1) Performs the division of BIN data specified at (S1) and the BIN data specified at (S2), and stores the result into the device specified at (D).

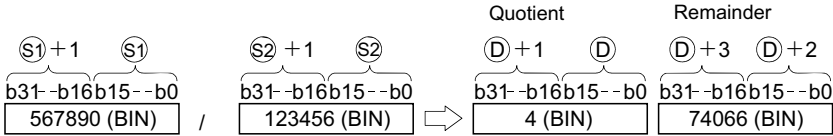

- (2) In regards to the operation result, the quotient and remainder are stored by use of 64 bits in the case of word device, and only the quotient is stored by use of 32 bits in the case of bit device.

Quotient : Stored to the lower 32 bits.  
 Remainder : Stored to the upper 32 bits. (Storable only in the case of word device)

- (3) At (S1) and (S2), -2147483648 to 2147483647 (BIN 32 bits) can be specified.  
 (4) Whether the data of (S1), (S2), (D) and (D)+2 are positive or negative is indicated at the highest bit (b31).  
 (Both quotient and remainder have sign.)  
 0 ..... Positive  
 1 ..... Negative

### Execution Conditions

The execution conditions of the transfer instructions are as shown below.

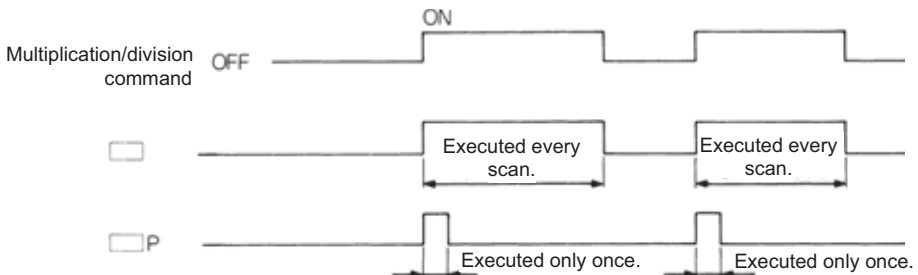



### Operation Errors

In the following case, operation error occurs and the error flag turns on.

- When A1 or V is assigned to (S1) or (S2). When A0, A1, Z, or V is assigned to (D).
- The divisor (S2) is 0.

### Program Examples

D\*

The program where the BIN data of D7 and D8 is multiplied by the BIN data of D18 and D19 at turn ON of X5, and the results are saved in D1 to D4.

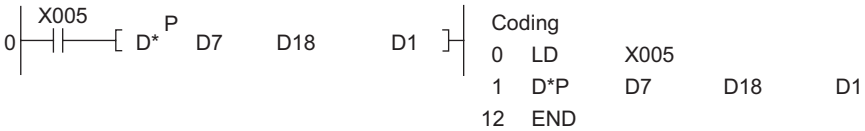

D/

The program where the data of M0 to M7 is multiplied by 3.14 at turn ON of X3, and the result is output to D3.

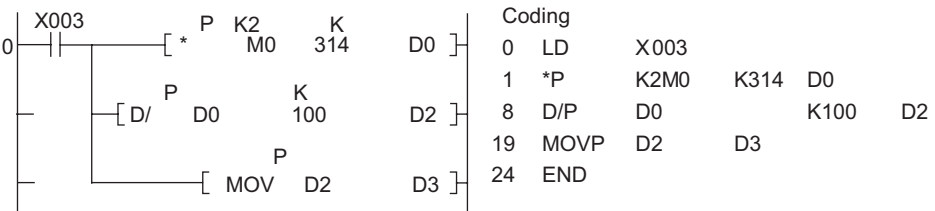



### 3.27.6 Data transfer instructions

The data transfer instructions are designed to transfer data.

The data moved by the data transfer instruction is maintained until new data is transferred.

### 3.27.7 Data transfer instructions : 32-bit data transfer ... DMOV, DMOVP

		Usable Devices									Digit Designation	Error Flag (M9010, M9011)
		Bit devices			Word (16-bit) devices			Constants		Level		
		X	Y	M	T	C	D	K	H	N		
DMOV,	(S)	○	○	○	○	○	○	○	○		K1 to K8	○
DMOVP	(D)		○	○	○	○	○					

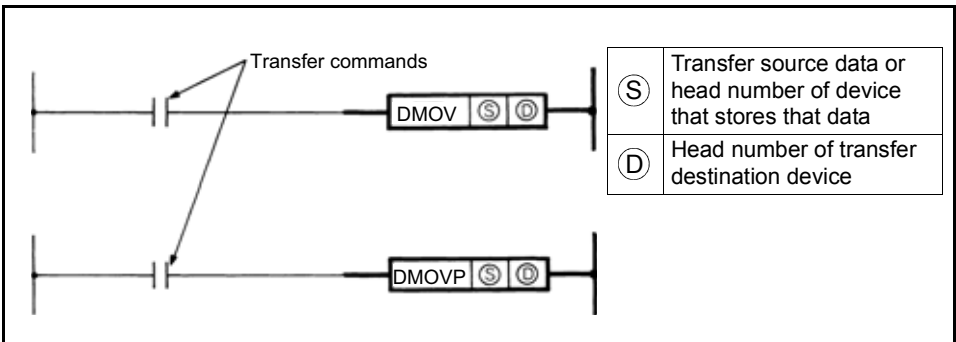

### Functions

DMOV

Transfers the 32-bit data of the device specified at (S) to the device specified at (D).

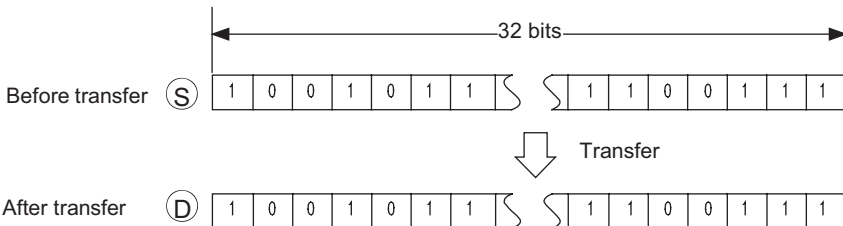

### Execution Conditions

The execution conditions of the transfer instructions are as shown below.

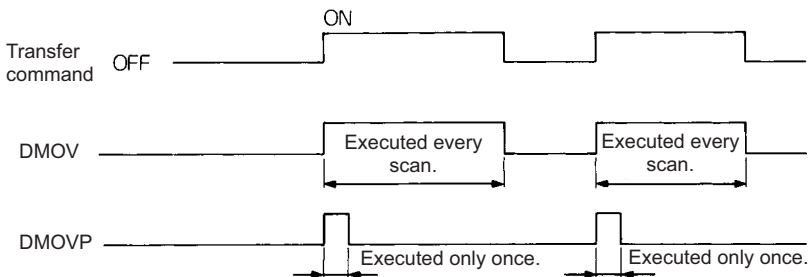

### Program Examples

#### DMOV

1) The program where the data of D2 and D3 is saved in D0 and D1.

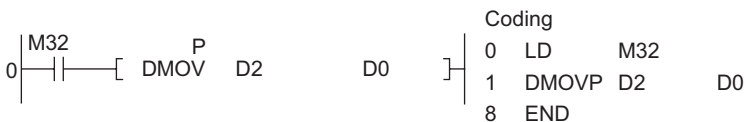

2) The program where the data of M0 to M31 is saved in D0 and D1.

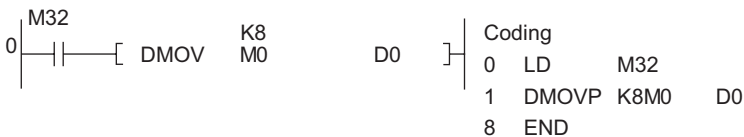





## 3.28 Application instructions

Application instructions are used when special processing is required.

### 3.28.1 Logical operation instructions

- (1) The logical operation instructions are instructions which perform the logical operations such as logical add and logical product.
- (2) The logical operation instructions are available in the following 10 types.

Classification	Instruction Symbol	Classification	Instruction Symbol	Classification	Instruction Symbol
Logical product	WAND	Exclusive OR	WXOR	2's complement (Sign reversal)	NEG
	WANDP		WXORP		NEGP
Logical add	WOR	Exclusive NOR	WXNR		
	WORP		WXNRP		

### REMARKS

The logical operation instructions perform the following processings in units of one bit.

Classification	Processing	Operation Expression	Example		
			A	B	Y
Logical product	Set to 1 only when both inputs A and B are 1. Set to 0 otherwise.	$Y=A \cdot B$	0	0	0
			0	1	0
			1	0	0
			1	1	1
Logical add	Set to 0 only when both inputs A and B are 0. Set to 1 otherwise.	$Y=A+B$	0	0	0
			0	1	1
			1	0	1
			1	1	1
Exclusive OR	Set to 0 when inputs A and B are equal. Set to 1 when they are different.	$Y=\bar{A} \cdot B + A \cdot \bar{B}$	0	0	0
			0	1	1
			1	0	1
			1	1	0
Exclusive NOR	Set to 1 when inputs A and B are equal. Set to 0 when they are different.	$Y = (\bar{A} + B) (A + \bar{B})$	0	0	1
			0	1	0
			1	0	0
			1	1	1

### 3.28.2 Logical operation instructions : 16-bit logical product ... WAND, WANDP

		Usable Devices									Digit Designation	Error Flag (M9010, M9011)
		Bit devices			Word (16-bit) devices			Constants		Level		
		X	Y	M	T	C	D	K	H	N		
WAND	(S)	○	○	○	○	○	○	○	○		K1 to K4	○
	(D)		○	○	○	○	○					
	(S1)	○	○	○	○	○	○	○	○			
	(S2)	○	○	○	○	○	○	○	○			
	(D1)		○	○	○	○	○					

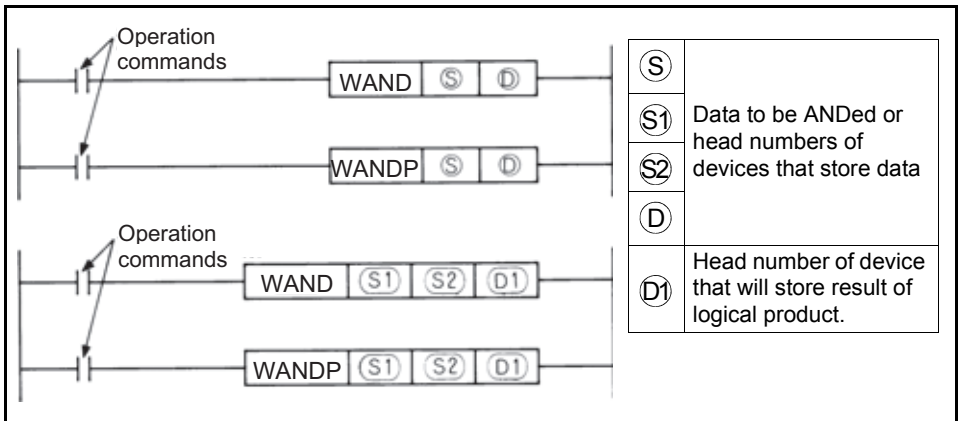

#### Functions

##### WAND

- ANDs the 16-bit data of the device specified at (D) and the 16-bit data of the device specified at (S) on a bit-by-bit basis, and stores the result into the device specified at (D).

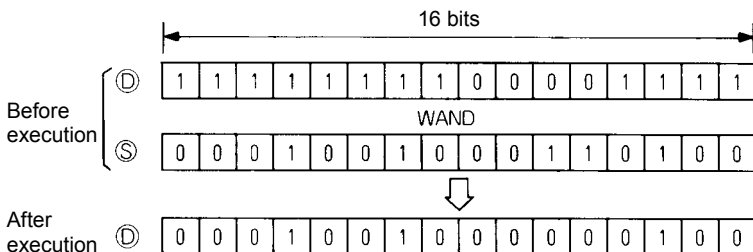



- (2) ANDs the 16-bit data of the device specified at (S1) and the 16-bit data of the device specified at (S2) on a bit-by-bit basis, and stores the result into the device specified at (D1).

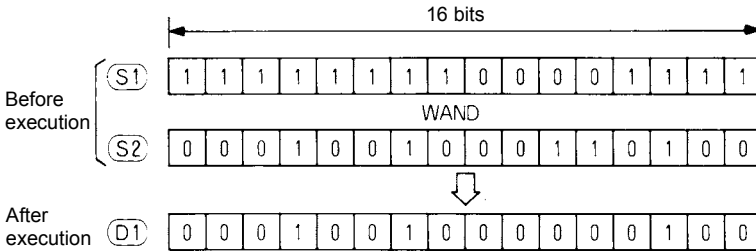

- (3) More than the digit designation of a bit device is regarded as 0 for operation.

### Execution Conditions

The execution conditions of the logical product instructions are as shown below.

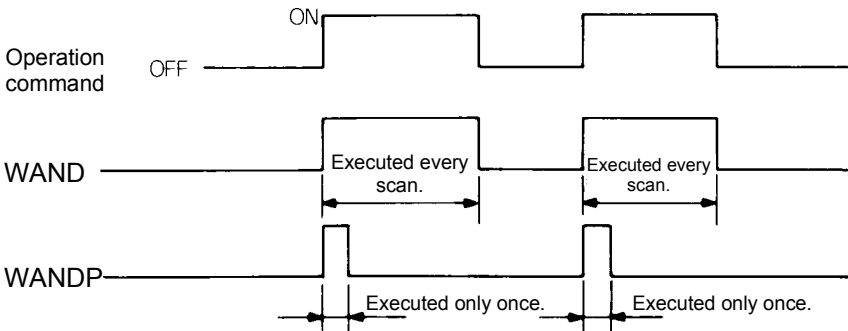

### Program Examples

#### WAND

- 1) Program that masks the tenth digit (second place from the least significant digit) with 0 among the four BCD digits of D10 when XA turns on.

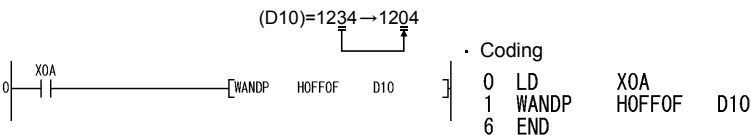



2) Program that ANDs the X10-1B and D33 data and outputs the result to Y0-B when XA turns on.

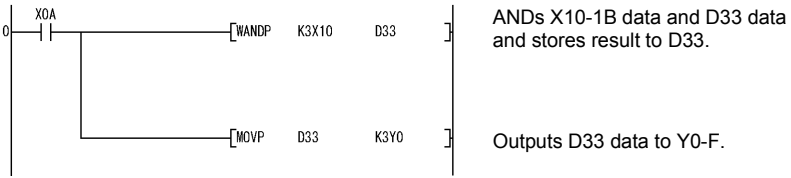

• Coding

```

0 LD      X0A
1 WANDP   K3X10  D33
6 MOV     D33    K3Y0
11 END

```

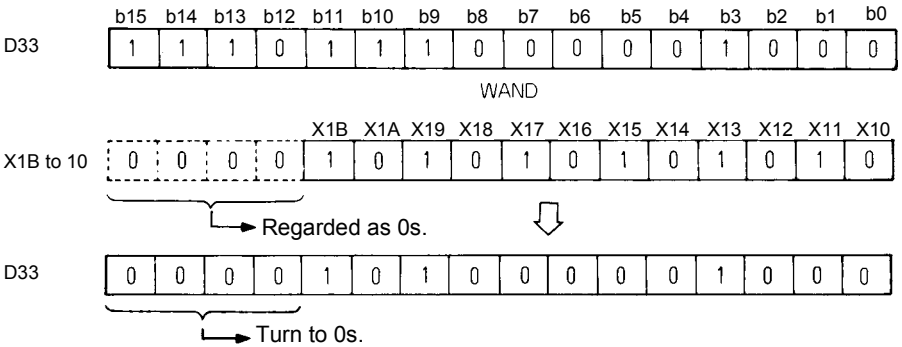

3) Program that ANDs the X10-1B and D33 data and outputs the result to Y0-B when XA turns on.

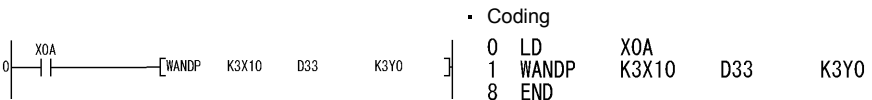

• Coding

```

0 LD      X0A
1 WANDP   K3X10  D33    K3Y0
8 END

```

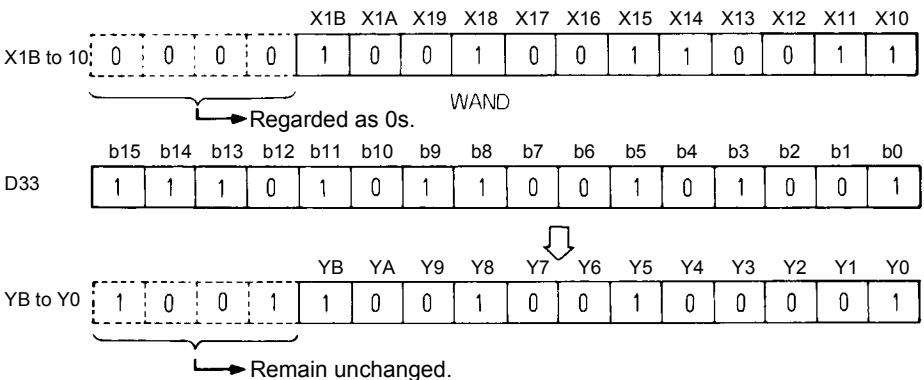



### 3.28.3 Logical operation instructions : 16-bit logical add ... WOR, WORP

		Usable Devices									Digit Designation	Error Flag (M9010, M9011)
		Bit devices			Word (16-bit) devices			Constants		Level		
		X	Y	M	T	C	D	K	H	N		
WOR	(S)	○	○	○	○	○	○	○	○		K1 to K4	○
	(D)		○	○	○	○	○					
	(S1)	○	○	○	○	○	○	○	○			
	(S2)	○	○	○	○	○	○	○	○			
	(D1)		○	○	○	○	○					

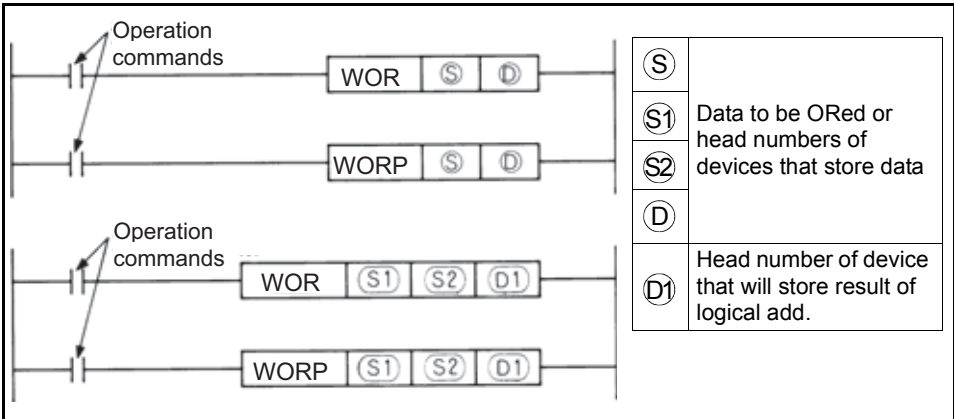

#### Functions

**WOR**

- ORs the 16-bit data of the device specified at (D) and the 16-bit data of the device specified at (S) on a bit-by-bit basis, and stores the result into the device specified at (D).

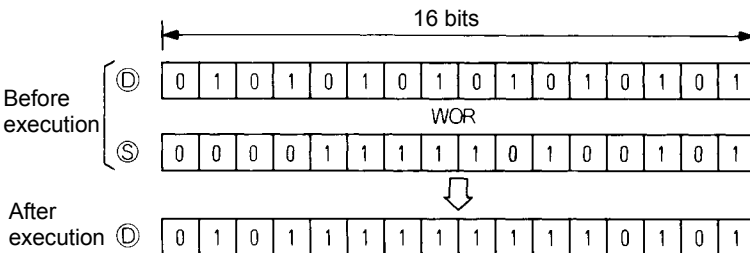

- (2) ORs the 16-bit data of the device specified at **S1** and the 16-bit data of the device specified at **S2** on a bit-by-bit basis, and stores the result into the device specified at **D1**.

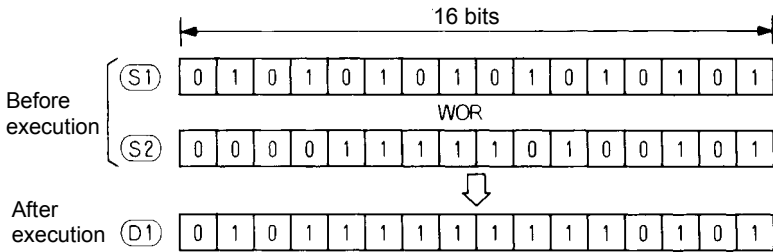

- (3) More than the digit designation of a bit device is regarded as 0 for operation.

### Execution Conditions

The execution conditions of the logical add instructions are as shown below.

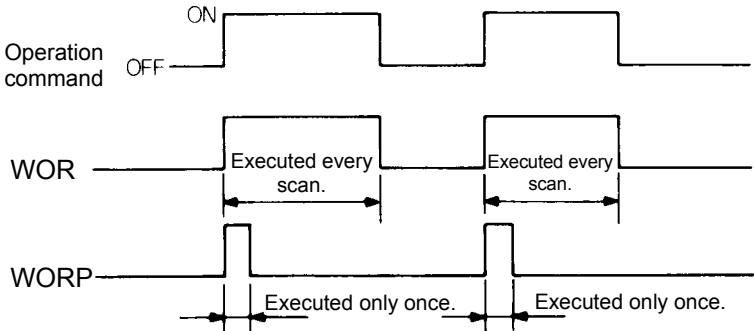

### Program Examples

#### WOR

- 1) Program that ORs the D10 and D20 data and stores the result into D10 when XA turns on.





2) Program that ORs the X10-1B and D33 data and outputs the result to Y0-F when XA turns on.

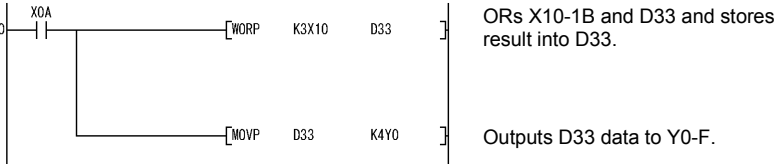

• Coding

```

0 LD X0A
1 WORP K3X10 D33
6 MOV P D33 K4Y0
11 END
    
```

3) Program that ORs the D10 and D20 data and stores the result into D33 when XA turns on.

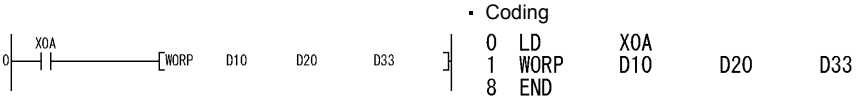

4) Program that ORs the X10-1B and D33 data and outputs the result to Y0-B when XA turns on.

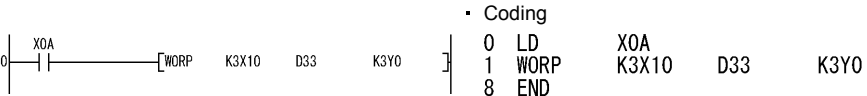

### 3.28.4 Logical operation instructions : 16-bit exclusive logical add ... WXOR, WXORP

		Usable Devices									Digit Designation	Error Flag (M9010, M9011)
		Bit devices			Word (16-bit) devices			Constants		Level		
		X	Y	M	T	C	D	K	H	N		
WXOR	Ⓢ	○	○	○	○	○	○	○	○		K1 to K4	○
	Ⓓ		○	○	○	○	○					
	Ⓢ1	○	○	○	○	○	○	○	○			
	Ⓢ2	○	○	○	○	○	○	○	○			
	Ⓓ1		○	○	○	○	○					

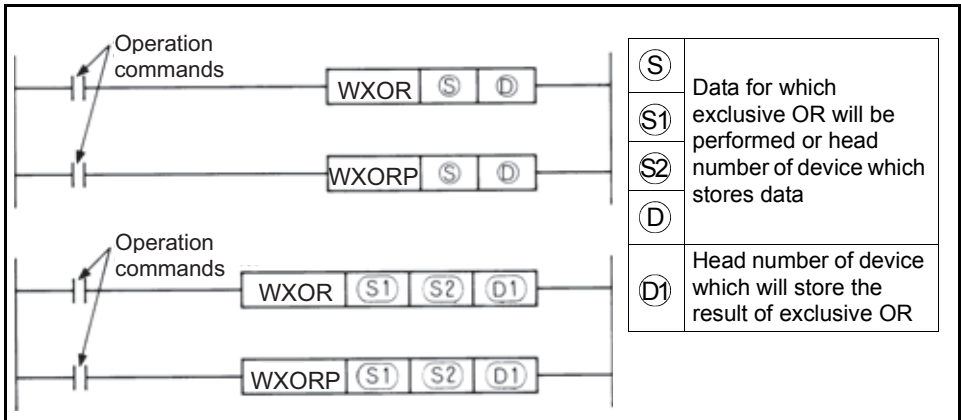





## Functions

### WXOR

- (1) Performs the exclusive OR of the 16-bit data of device specified at (D) and the 16-bit data of device specified at (S) per bit, and stores the result into the device specified at (D).

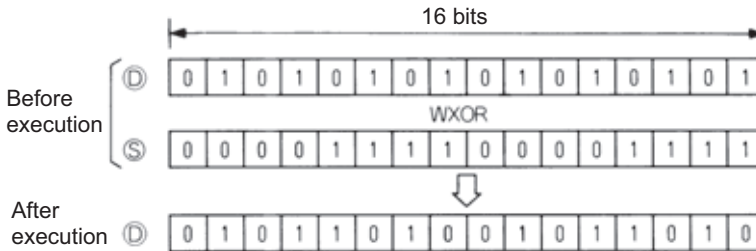

- (2) Performs the exclusive OR of the 16-bit data of device specified at (S1) and the 16-bit data of device specified at (S2) per bit, and stores the result into the device specified at (D).

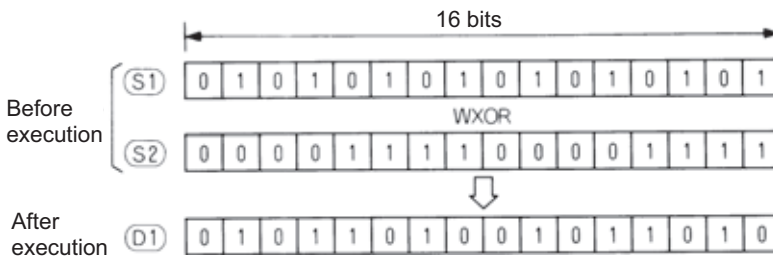

- (3) When operation is performed, the digits of bit device higher than the specified are regarded as 0.

## Execution Conditions

The execution conditions of the exclusive logical add instructions are as shown below.

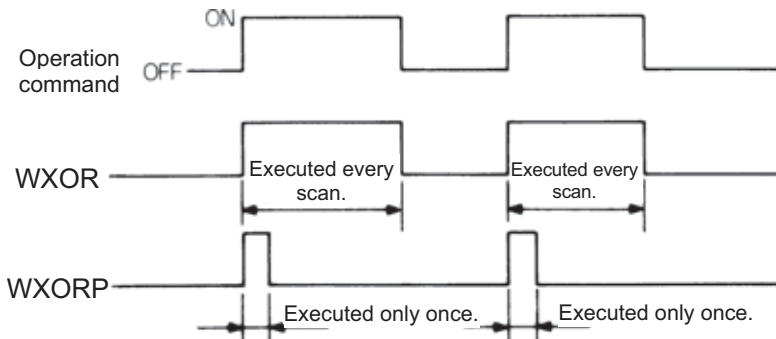

## Program Examples

### WXOR

- 1) Program which performs exclusive OR of the data of D10 and that of D20, and stores the result to D10 when XA turns on.



- 2) Program which performs the exclusive OR of the data of X10 to 1B and data of D33, and sends the result to the Y30 to 3B when XA turns on.

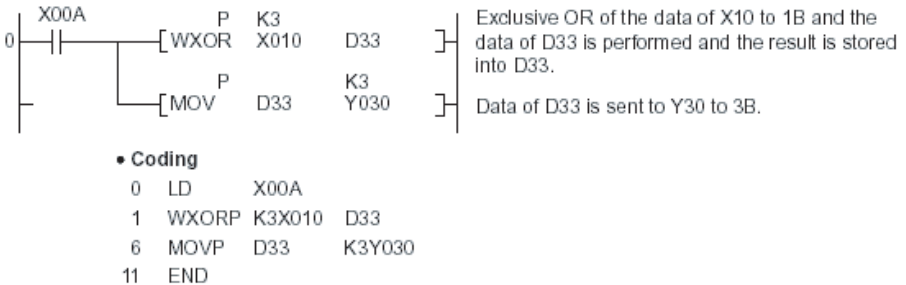

- 3) Program which performs exclusive OR of the data of D10 and that of D20, and stores the result to D33 when XA turns on.

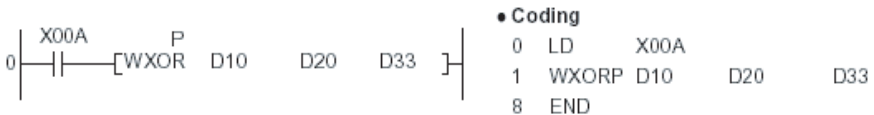

- 4) Program which performs exclusive OR of the data of X10 to 1B and the data of D33, and sends the result to the Y30 to 3B when XA turns on.

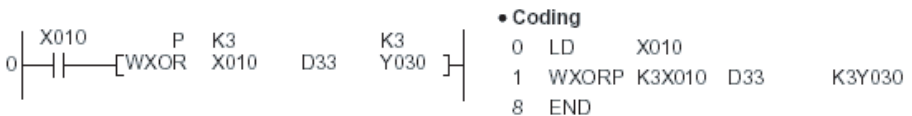



### 3.28.5 Logical operation instructions : 16-bit not exclusive logical add ... WXNR, WXNRP

		Usable Devices									Digit Designation	Error Flag
		Bit devices			Word (16-bit) devices			Constants		Level		
		X	Y	M	T	C	D	K	H	N		(M9010, M9011)
WXNR	(S)	○	○	○	○	○	○	○	○		K1 to K4	○
	(D)		○	○	○	○	○					
	(S1)	○	○	○	○	○	○	○	○			
	(S2)	○	○	○	○	○	○	○	○			
	(D1)		○	○	○	○	○					

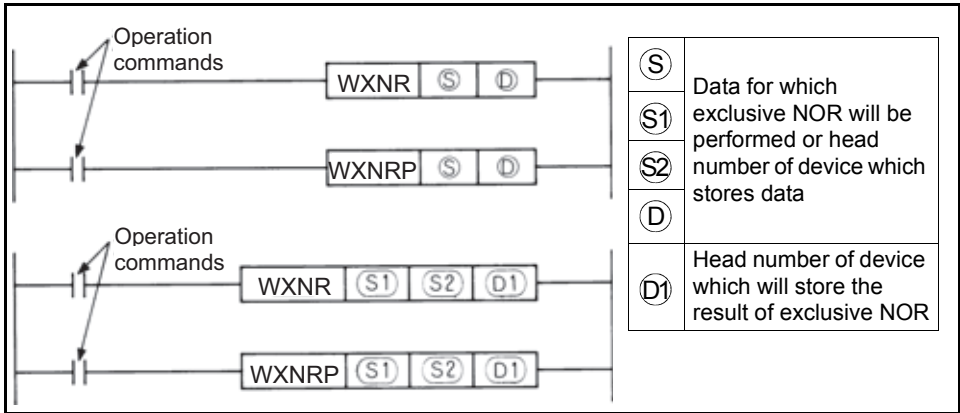

## Functions

### WXNR

- (1) Performs the exclusive NOR of the 16-bit data of device specified at (D) and the 16-bit data of device specified at (S) per bit, and stores the result into the device specified at (D).

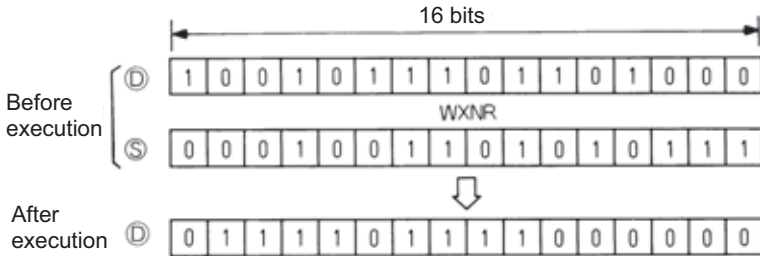

- (2) Performs the exclusive NOR of the 16-bit data of device specified at (S1) and the 16-bit data of device specified at (S2) per bit, and stores the result into the device specified at (D).

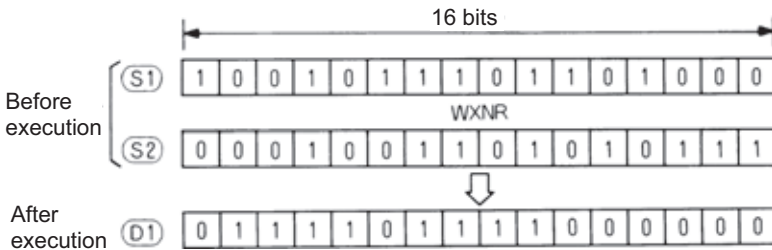

- (3) When operation is performed, the digits of bit device higher than the specified are regarded as 0.

## Execution Conditions

The execution conditions of the not exclusive logical add instructions are as shown below.

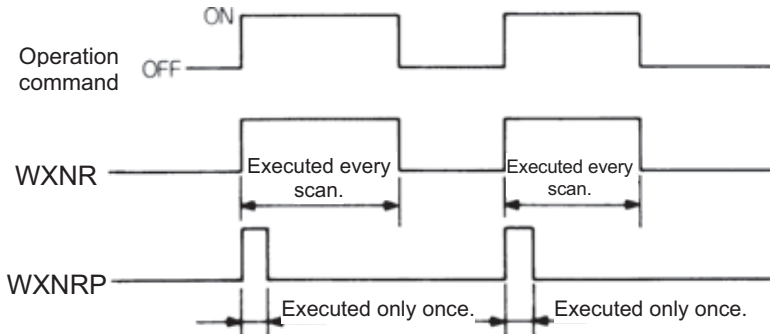



## Program Examples

### WXNR

- 1) Program which compares the bit pattern of the 16-bit data of X30 to 3F and that of the 16-bit data of D99 and stores the number of the same bit patterns and the number of different bit patterns to D7 and 8, respectively, when XC turns on.

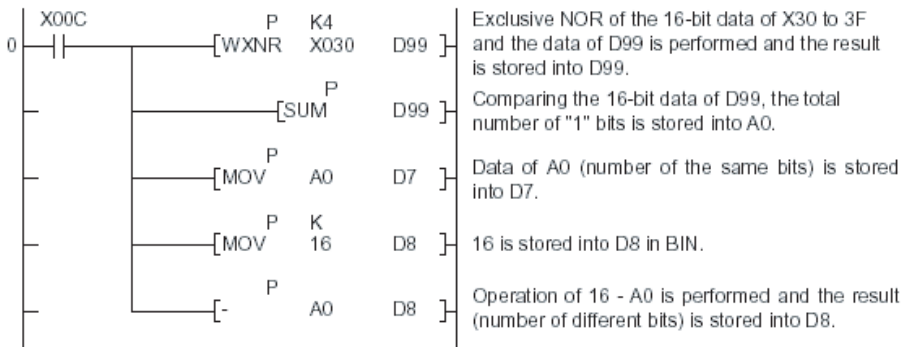

#### • Coding

```

0 LD X00C
1 WXNRP K4X030 D99
6 SUMP D99
9 MOVP A0 D7
14 MOVP K16 D8
19 -P A0 D8
24 END
  
```

- 2) Program which compares the bit pattern of the 16-bit data of X30 to 3F and that of the data of D99 and stores the result to D7 when X0 turns on.



### 3.28.6 Logical operation instructions : BIN 16-bit 2's complement ... NEG, NEGP

		Usable Devices									Digit Designation	Error Flag (M9010, M9011)
		Bit devices			Word (16-bit) devices			Constants		Level		
		X	Y	M	T	C	D	K	H	N		
NEG	Ⓓ		○	○	○	○	○	○	○		K1 to K4	○

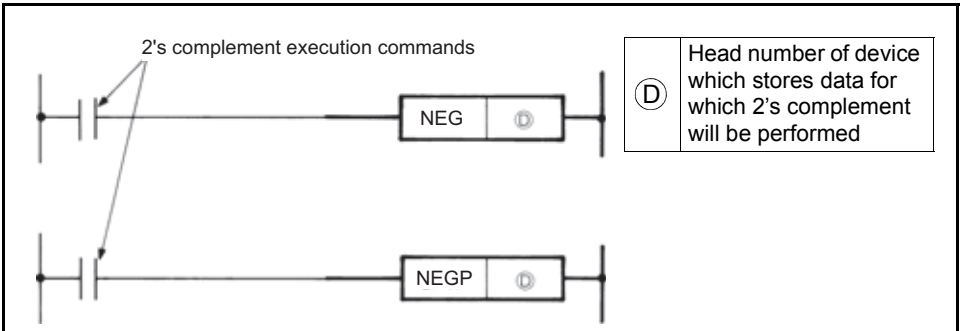

#### Functions

- (1) Reverses the sign of the 16-bit data of device specified at Ⓓ and stores the result in device specified at Ⓓ.

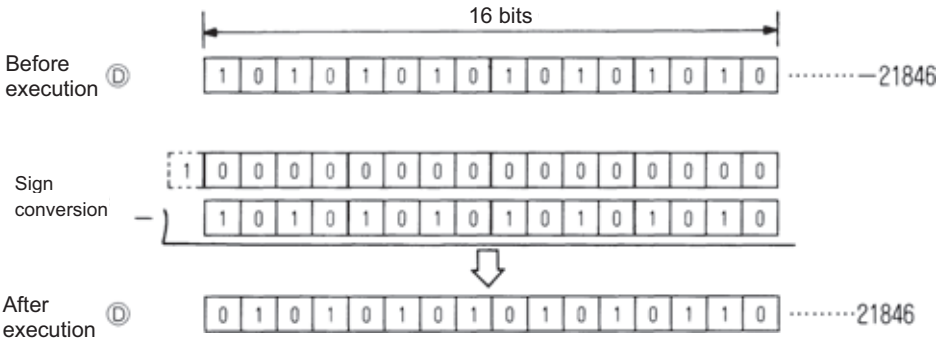

- (2) Used to reverse the positive sign to the negative sign and vice versa.



## Execution Conditions

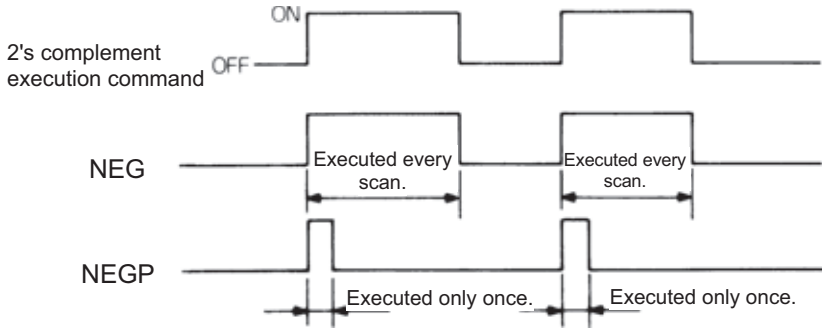

## Program Examples

### NEG

1) Program which calculates "D10 - D20" when XA turns on, and obtains the absolute value when the result is negative.

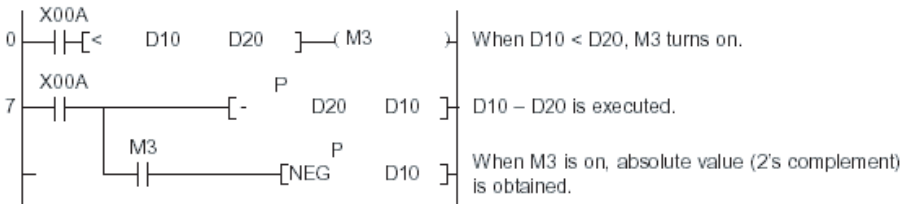

#### • Coding

```

0 LD X00A
1 AND< D10 D20
6 OUT M3
7 LD X00A
8 -P D20 D10
13 AND M3
14 NEGP D10
17 END
    
```

## 3.29 Display command

### 3.29.1 PU display function command ... PR

		Usable Devices									Digit Designation	Error Flag
		Bit devices			Word (16-bit) devices			Constants		Level		
		X	Y	M	T	C	D	K	H	N		(M9010, M9011)
PR	Ⓢ				○	○	○					○
	Ⓓ		○									

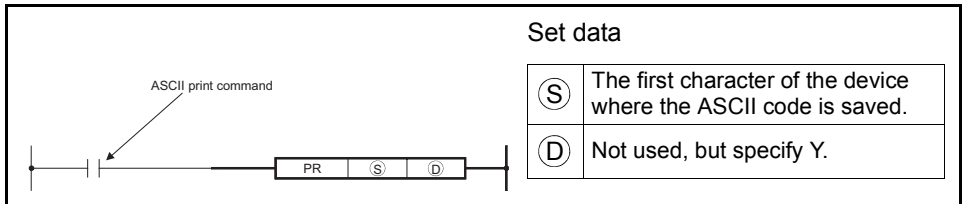

#### Functions

For the device specified by Ⓢ, register the device of the code to be displayed on FR-PU07-01.

Ⓓ is not used, but specify Y.





(1) Set data: monitors

	Upper 8 bits	Lower 8 bits	
Ⓢ+0		01	←Set the corresponding monitor number in the upper 8 bits, and set "01" in the lower 8 bits.
	2nd character	1st character	←Monitored item name: first character
	4th character	3rd character	
	6th character	5th character	
	8th character	7th character	
	10th character	9th character	
	12th character	11th character	
	2nd character	1st character	←Unit: first character
Ⓢ+8	—	3rd character	

To set a monitored item, set "01" in the lower 8 bits of Ⓢ+0.

For the upper 8 bits of Ⓢ+0, set the monitored item to be replaced to on the display. Refer to the below table for the number of each monitored item.

Number of monitored item	Monitored item
40(H28)	User monitor 1
41(H29)	User monitor 2
42(H2A)	User monitor 3

\* The calculation error (error code 50) occurs if a value other than above is set in the upper 8 bits of Ⓢ+0.

Ignore the upper 8 bits of Ⓢ+8.

Designating the seventh bit of Ⓢ+0 as "1" (lower 8 bits are H81) clears the setting and changes the display back to the normal monitor display.

**REMARKS**

- To display the above monitored items on FR-PU07-01, set "40, 41, or 42" in Pr.774 to Pr.776. (Refer to the *Instruction Manual of the inverter* for the details of Pr.774 to Pr.776.)

**(2) Set data: faults**

	Upper 8 bits	Lower 8 bits	
Ⓢ+0		02	←Set the corresponding fault number in the upper 8 bits, and set "02" in the lower 8 bits.
	2nd character	1st character	←Fault name: first character
	4th character	3rd character	
	6th character	5th character	
	8th character	7th character	
	10th character	9th character	
Ⓢ+6	12th character	11th character	

Set the corresponding fault number in the upper 8 bits of Ⓢ+0.

Setting range for the upper 8 bits of Ⓢ+0 is "16 to 20." If a value other than "16 to 20" is set, the calculation error (error code 50) occurs.

Designating the seventh bit of Ⓢ+0 as "1" (lower 8 bits are H82) clears the setting and the change the display back to the normal fault display.



(3) Set data: parameters

	Upper 8 bits	Lower 8 bits	
Ⓢ+0		03	←Set the corresponding parameter number in the upper 8 bits, and set "03" in the lower 8 bits.
	2nd character	1st character	←Parameter name: first character
	4th character	3rd character	
	6th character	5th character	
	8th character	7th character	
	—	9th character	
	2nd character	1st character	←Unit: first character
Ⓢ+7	—	3rd character	

Set the corresponding parameter number in the upper 8 bits of Ⓢ+0.  
 Refer to the below table for the parameter numbers and settings.

Setting	Parameter Number
01(H01)	Pr.506
02(H02)	Pr.507
03(H03)	Pr.508
04(H04)	Pr.509
05(H05)	Pr.510
06(H06)	Pr.511
07(H07)	Pr.512
08(H08)	Pr.513
09(H09)	Pr.514
10(H0A)	Pr.515

\* The calculation error (error code 50) occurs if a value other than above is set in the upper 8 bits of Ⓢ+0.

Ignore the upper 8 bits of Ⓢ+5 and Ⓢ+7.

Designating the seventh bit of Ⓢ+0 as "1" (lower 8 bits are H83) clears the setting and changes the display back to the normal parameter number display.

#### (4) Number of selectable items

Set data	Number of selectable items
Monitor (Refer to page 194.)	Up to 3 items
Fault (Refer to page 195.)	Up to 5 items
Parameter (Refer to page 196.)	Up to 10 items

\* If a set data is set exceeding the number of selectable items, the calculation error (error code 50) occurs at execution of the setting.

If a value other than "01 to 03" is set in the lower 8 bits of (S)+0, the calculation error (error code 50) occurs.

### CAUTION

**•If the data is larger than the storable size of the applicable devices, the exceeded data will modify other devices although no error will occur. Before storing data, make sure to have enough devices available to store the data.**

### REMARKS

- Do not change the data in each device while it is being displayed. The data in the device is used for actual communication. If data is changed while it is being displayed, the data to be transmitted also changes. The device number, where the first character of the set data is set, is registered in the inverter.
- The characters other than ASCII data 0x20 to 0x7A, which can be displayed on FR-PU07-01, are replaced by 0x20 (spaces).
- The following characters cannot be displayed on FR-PU07-01: [ ^ ] (H5E), [ \_ ] (H5F), and [ ' ] (H60).

### Execution Conditions

See below for the execution conditions of the PR command.

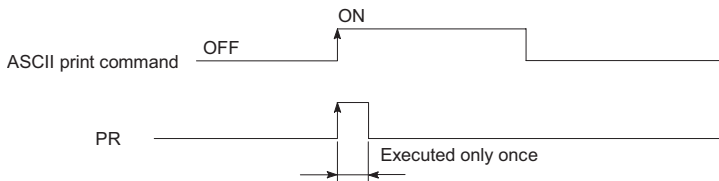



### 3.29.2 ASCII code conversion command ... ASC

		Usable Devices									Digit Designation	Error Flag (M9010, M9011)
		Bit devices			Word (16-bit) devices			Constants		Level		
		X	Y	M	T	C	D	K	H	N		
ASC	Ⓓ				○	○	○	○	○			○

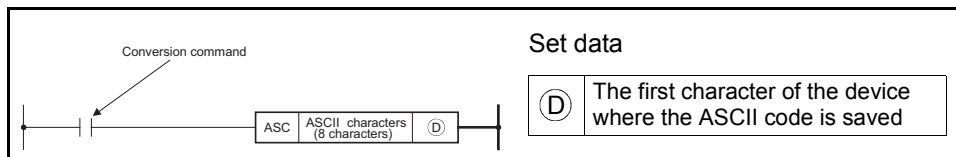

#### Functions

Convert the specified alphanumeric characters to the ASCII code, and save it to the four devices specified by Ⓓ.

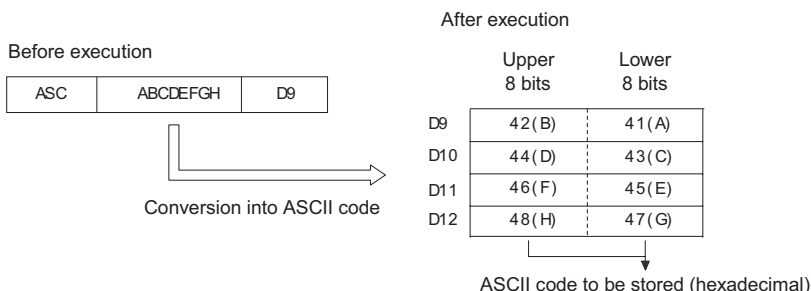

#### CAUTION

- If the data is larger than the storable size of the applicable devices, the exceeded data will modify other devices although no error will occur. Before storing data, make sure to have enough devices available to store the data.

#### REMARKS

- Always use four devices for the ASC command. If the set characters are less than 8 characters, the blank area is filled with spaces to make up to 8 characters in total.
- Because of how GX Developer operates, the symbol [ " ] and lower-case English characters cannot be specified. To display these symbol and characters, specify with ASCII code directly.



### Execution Conditions

See below for the execution conditions of the ASC command.

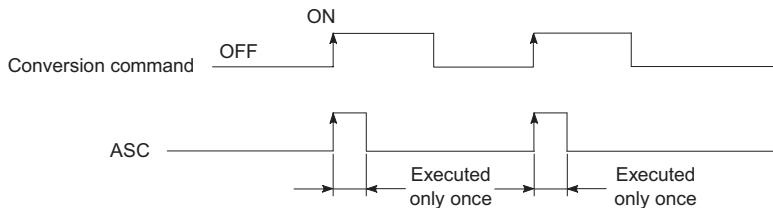

### Program Examples

#### ASC

Program which converts "ABCDEFGH IJKLMNOP" into the ASCII code and stores the result to the D88 to 95 when X8 turns on.

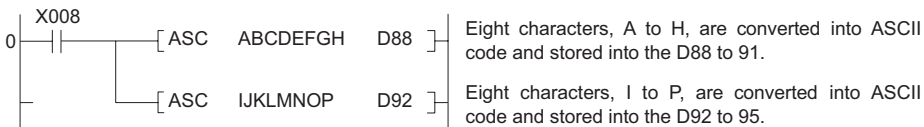

```

• Coding
0 LD X008
1 ASC ABCDEFGH D88
14 ASC IJKLMNOP D92
27 END

```

# MEMO

# 4. ERROR CODE LIST

4.1 How to read the error code..... 202

Chapter 1

Chapter 2

Chapter 3

Chapter 4





When the built-in PLC function is in the RUN status or if an alarm occurs during RUN, the self-diagnostic function displays the error and stores the error code and error step into the special registers. This chapter describes the error definitions and corrective actions.

## 4.1 How to read the error code

When an error has occurred, the error code can be read with the peripheral device. For the operation method, refer to the operating manual of the peripheral device. The following table indicates the error names, error codes, definitions, causes and corrective actions.

The error code and error step are stored into the following special registers.

Error code..... D9008

Error step..... D9010, D9011

Table 4.1 Error Code List

Error Name	Error Code (D9008)	Status	Definition and Cause	Corrective Action
"INSTRCT CODE ERR." [Checked at instruction execution]	10	Stop	The instruction code that cannot be decoded is included in the program. • The memory contents changed for some reason.	Read the error step using GX Developer, and correct that step in the program.
"PARAMETER ERROR" [Checked at power-on or STOP to RUN]	11	Stop	(1) Write to the CPU was performed after the capacity larger than the memory capacity of the CPU was set using GX Developer. (2) The parameter data of the CPU memory changed due to noise or memory loading fault.	Check the memory capacity of the CPU with the memory capacity set using GX Developer, and re-set using GX Developer.
"WDT ERROR" [Checked at END processing execution]	22	Stop	The scan time exceeds the watchdog error monitor time. • The user program scan time has increased.	Calculate/check the user program scan time and reduce the scan time.
"END NOT EXECUTE" [Checked at END instruction execution]	24	Stop	(1) The END instruction has been read as another instruction code due to noise, etc. (2) The END instruction has changed into another instruction code for some reason.	Reset and RUN again. If the same error appears again, the cause is a CPU hardware fault. Consult the Mitsubishi representative.

Error Name	Error Code (D9008)	Status	Definition and Cause	Corrective Action
"OPERATION ERROR" [Checked at instruction execution]	50	Run (Stop)	(1) Divided by zero  (2) When using the PR command <ul style="list-style-type: none"> <li>• A value other than "01 to 03" is set in the lower 8 bits of (S)+0.</li> <li>• A value out of the setting range is set in the upper 8 bits of (S)+0.</li> <li>• Monitors, faults, and parameters are set exceeding the number of selectable items.</li> </ul>	(1) Read the error step by use of peripheral device, and check and correct the program at that step.  (2) <ul style="list-style-type: none"> <li>• Set a value from "01 to 03" in the lower 8 bits of (S)+0.</li> <li>• Check the upper 8 bits of (S)+0.</li> <li>• Set monitors, faults, parameters within the number of selectable items.</li> </ul>

# MEMO

# APPENDIX

**Appendix 1 Instruction processing time..... 206**



# Appendix 1 Instruction processing time

Instruction	Condition (Device)	Number of Steps	Processing Time ( $\mu$ s)
LD		1	2.6
LDI		1	2.7
AND		1	2.8
ANI		1	2.8
OR		1	2.7
ORI		1	2.8
ORB		1	2.0
ANB		1	2.0
MPS		1	1.9
MRD		1	1.9
MPP		1	2.0
MC		5	3.7
MCR		3	2.4
NOP		1	2.1
NOPLF		1	2.1
END		1	1.3
PLS		3	3.6
PLF		3	3.5
SFT		3	3.6
SFTP		3	4.1
OUT	Y,M	1	2.5
	Special M	3	3.2
	T	1	2.5
	C	1	2.6
SET	Y,M	1	2.5
	Special M	3	3.1
RST	Y,M	1	2.6
	Special M	3	3.3
	T	3	3.8
	C	3	3.8
	D	3	3.2
MOV		5	7.7
DMOV		7	15.1
MOVP		5	8.5
DMOVP		7	15.8
WAND		5	10.3
WANDP		5	10.7
WAND		7	10.1
WANDP		7	10.7

Instruction	Condition (Device)	Number of Steps	Processing Time ( $\mu$ s)
WOR		5	10.3
WORP		5	10.7
WOR		7	10.2
WORP		7	10.6
WXOR		5	10.4
WXORP		5	10.8
WXOR		7	10.3
WXORP		7	10.7
WXNR		5	10.5
WXNRP		5	10.9
WXNR		7	10.3
WXNRP		7	10.7
NEG		3	7.7
NEGP		3	8.1
LD=		5	7.7
LD=		7	8.3
LDD=		11	15.2
LD<>		5	7.8
LD<>		7	8.3
LDD<>		11	15.2
LD>		5	7.7
LD>		7	8.3
LDD>		11	15.2
LD<=		5	7.8
LD<=		7	8.3
LDD<=		11	15.2
LD<		5	7.8
LD<		7	8.3
LDD<		11	15.2
LD>=		5	7.9
LD>=		7	8.3
LDD>=		11	15.2
AND=		5	7.3
AND=		7	7.5
ANDD=		11	14.9
AND<>		5	7.4
AND<>		7	7.5
ANDD<>		11	14.9



Instruction	Condition (Device)	Number of Steps	Processing Time ( $\mu$ S)
AND>		5	7.4
AND>		7	7.5
ANDD>		11	14.9
AND<=		5	7.5
AND<=		7	7.7
ANDD<=		11	14.9
AND<		5	7.4
AND<		7	7.7
ANDD<		11	15.0
AND>=		5	7.5
AND>=		7	7.7
ANDD>=		11	14.9
OR=		5	7.4
OR=		7	8.1
ORD=		11	17.2
OR<>		5	7.5
OR<>		7	8.2
ORD<>		11	17.3
OR>		5	7.5
OR>		7	8.2
ORD>		11	15.1
OR<=		5	7.5
OR<=		7	8.2
ORD<=		11	15.2
OR<		5	7.5
OR<		7	8.2
ORD<		11	15.2
OR>=		5	7.6
OR>=		7	8.2
ORD>=		11	15.2

Instruction	Condition (Device)	Number of Steps	Processing Time ( $\mu$ S)
+		5	10.3
+P		5	10.7
+		7	10.3
+P		7	10.7
D+		9	15.5
D+P		9	16.1
D+		11	15.6
D+P		11	16.1
-		5	10.3
-P		5	10.7
-		7	10.4
-P		7	10.8
D-		9	15.6
D-P		9	16.1
D-		11	15.6
D-P		11	16.1
*		7	10.8
*P		7	11.3
/		7	11.3
/P		7	11.8
D*		11	16.2
D*P		11	16.7
D/		11	16.6
D/P		11	17.2
PR		7	14.4
ASC		13	26.7

**REMARKS**

As inverter control is also performed actually, the scan time is approximately 40ms at 500 steps.

# REVISIONS

\*The manual number is given on the bottom left of the back cover

Print Date	*Manual Number	Revision	
May 2010	IB(NA)-0600420ENG-A	First edition	
Jul. 2010	IB(NA)-0600420ENG-B	<table border="1"><tr><td>Addition</td></tr></table> <ul style="list-style-type: none"><li>• D9213 PID measured value 2</li><li>• D9228 BACnet reception status</li></ul>	Addition
Addition			
Mar. 2012	IB(NA)-0600420ENG-C	<table border="1"><tr><td>Addition</td></tr></table> <ul style="list-style-type: none"><li>• FR-F700-EC series</li></ul>	Addition
Addition			

