

MELFA Robots





Industrial Robot

Instruction Manual
(Robot Arm Setup & Maintenance)

RV-3SQ/3SQJ

Safety Precautions

Always read the following precautions and the separate "Safety Manual" before starting use of the robot to learn the required measures to be taken.

-  **CAUTION** All teaching work must be carried out by an operator who has received special training. (This also applies to maintenance work with the power source turned ON.)
Enforcement of safety training
-  **CAUTION** For teaching work, prepare a work plan related to the methods and procedures of operating the robot, and to the measures to be taken when an error occurs or when restarting. Carry out work following this plan. (This also applies to maintenance work with the power source turned ON.)
Preparation of work plan
-  **WARNING** Prepare a device that allows operation to be stopped immediately during teaching work. (This also applies to maintenance work with the power source turned ON.)
Setting of emergency stop switch
-  **CAUTION** During teaching work, place a sign indicating that teaching work is in progress on the start switch, etc. (This also applies to maintenance work with the power source turned ON.)
Indication of teaching work in progress
-  **WARNING** Provide a fence or enclosure during operation to prevent contact of the operator and robot.
Installation of safety fence
-  **CAUTION** Establish a set signaling method to the related operators for starting work, and follow this method.
Signaling of operation start
-  **CAUTION** As a principle turn the power OFF during maintenance work. Place a sign indicating that maintenance work is in progress on the start switch, etc.
Indication of maintenance work in progress
-  **CAUTION** Before starting work, inspect the robot, emergency stop switch and other related devices, etc., and confirm that there are no errors.
Inspection before starting work

The points of the precautions given in the separate "Safety Manual" are given below. Refer to the actual "Safety Manual" for details.

-  **CAUTION** Use the robot within the environment given in the specifications. Failure to do so could lead to a drop or reliability or faults. (Temperature, humidity, atmosphere, noise environment, etc.)
-  **CAUTION** Transport the robot with the designated transportation posture. Transporting the robot in a non-designated posture could lead to personal injuries or faults from dropping.
-  **CAUTION** Always use the robot installed on a secure table. Use in an instable posture could lead to positional deviation and vibration.
-  **CAUTION** Wire the cable as far away from noise sources as possible. If placed near a noise source, positional deviation or malfunction could occur.
-  **CAUTION** Do not apply excessive force on the connector or excessively bend the cable. Failure to observe this could lead to contact defects or wire breakage.
-  **CAUTION** Make sure that the workpiece weight, including the hand, does not exceed the rated load or tolerable torque. Exceeding these values could lead to alarms or faults.
-  **WARNING** Securely install the hand and tool, and securely grasp the workpiece. Failure to observe this could lead to personal injuries or damage if the object comes off or flies off during operation.
-  **WARNING** Securely ground the robot and controller. Failure to observe this could lead to malfunctioning by noise or to electric shock accidents.
-  **CAUTION** Indicate the operation state during robot operation. Failure to indicate the state could lead to operators approaching the robot or to incorrect operation.
-  **WARNING** When carrying out teaching work in the robot's movement range, always secure the priority right for the robot control. Failure to observe this could lead to personal injuries or damage if the robot is started with external commands.
-  **CAUTION** Keep the jog speed as low as possible, and always watch the robot. Failure to do so could lead to interference with the workpiece or peripheral devices.
-  **CAUTION** After editing the program, always confirm the operation with step operation before starting automatic operation. Failure to do so could lead to interference with peripheral devices because of programming mistakes, etc.
-  **CAUTION** Make sure that if the safety fence entrance door is opened during automatic operation, the door is locked or that the robot will automatically stop. Failure to do so could lead to personal injuries.
-  **CAUTION** Never carry out modifications based on personal judgments, or use non-designated maintenance parts.
Failure to observe this could lead to faults or failures.
-  **WARNING** When the robot arm has to be moved by hand from an external area, do not place hands or fingers in the openings. Failure to observe this could lead to hands or fingers catching depending on the posture.

⚠ CAUTION Do not stop the robot or apply emergency stop by turning the robot controller's main power OFF. If the robot controller main power is turned OFF during automatic operation, the robot accuracy could be adversely affected. Moreover, it may interfere with the peripheral device by drop or move by inertia of the arm.

⚠ CAUTION Do not turn off the main power to the robot controller while rewriting the internal information of the robot controller such as the program or parameters. If the main power to the robot controller is turned off while in automatic operation or rewriting the program or parameters, the internal information of the robot controller may be damaged.

⚠ CAUTION Use the USB devices confirmed by manufacturer. In other case, it might have care difficulty by the effect of temperature, noise and so on. When using it, measures against the noise, such as measures against EMI and the addition of the ferrite core, may be necessary. Please fully confirm of the operation by the customer

C. Notes of the basic component are shown.

*SQ series: CR1QA-700 series

⚠ CAUTION Please install the earth leakage breaker in the primary side supply power supply of the controller because of leakage protection.

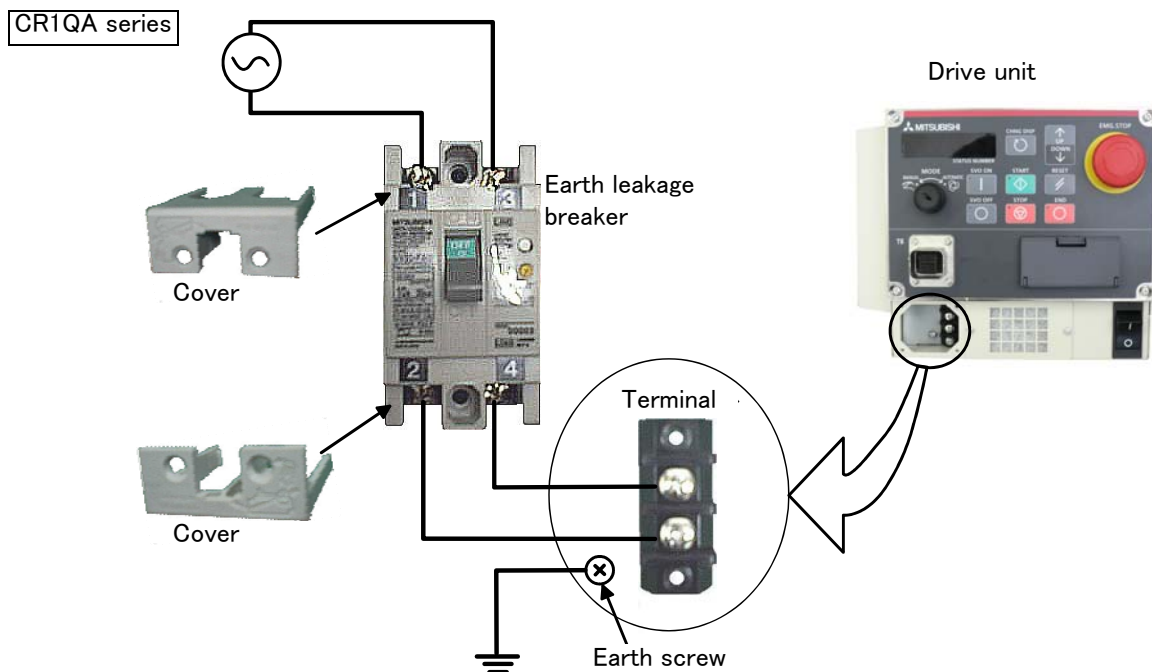

Revision history

Date of Point	Instruction Manual No.	Revision Details
2008-10-28	BFP-A8698	First print
2009-06-20	BFP-A8698-A	The caution at pulling out spare wiring was added.
2009-10-29	BFP-A8698-B	The EC Declaration of Conformity was changed. (Correspond to the EMC directive; 2006/42/EC) Work jog function was added.
2010-07-09	BFP-A8698-C	The type name of the controller was changed. (CR1Q to CR1QA, CR2Q to CR2QA)

■ Introduction

Thank you for purchasing the Mitsubishi industrial robot.

This instruction manual explains procedures to be taken for unpacking, installing, servicing and inspecting the robot arm.

Always read through this manual before starting use to ensure correct usage of the robot.

The contents of this manual correspond to the following robot types.

- | | | |
|--------|------------------|---------------|
| <Type> | ▪ RV-3SQ series | : 6-axis type |
| | ▪ RV-3SQJ series | : 5-axis type |

- No part of this manual may be reproduced by any means or in any form, without prior consent from Mitsubishi.
- The details of this manual are subject to change without notice.
- An effort has been made to make full descriptions in this manual. However, if any discrepancies or unclear points are found, please contact your dealer.
- The information contained in this document has been written to be accurate as much as possible. Please interpret that items not described in this document "cannot be performed." or "alarm may occur".
Please contact your nearest dealer if you find any doubtful, wrong or skipped point.
- This specifications is original.

Copyright(C) 2008-2010 MITSUBISHI ELECTRIC CORPORATION

Contents

	Page
1 Before starting use	1-1
1.1 Using the instruction manuals	1-1
1.1.1 The details of each instruction manuals	1-1
1.1.2 Terminological definition	1-2
1.1.3 Symbols used in instruction manual	1-2
1.2 Safety Precautions	1-3
1.2.1 Precautions given in the separate Safety Manual	1-4
2 Unpacking to Installation	2-6
2.1 Confirming the product	2-6
2.2 Installation	2-7
2.2.1 Unpacking	2-7
2.2.2 Transportation procedures(Transportation by people)	2-8
2.2.3 Installation procedures	2-9
2.2.4 Grounding procedures	2-11
(1) Grounding methods	2-11
(2) Grounding procedures	2-11
2.2.5 Connecting with the controller	2-12
2.3 Spare wiring	2-14
2.3.1 Base area	2-16
2.3.2 Connection of piping for air pressurization	2-18
2.3.3 Connection of piping for suction	2-18
2.4 Setting the origin	2-19
2.4.1 Installing the teaching pendant (T/B)	2-19
2.4.2 Setting the origin with the origin data input method	2-20
(1) Confirming the origin data	2-20
(2) Turning ON the control power	2-20
(3) Preparing the T/B	2-21
(4) Selecting the origin setting method	2-22
(5) Inputting the origin data	2-23
(6) Installing the shoulder cover A.	2-24
2.5 Confirming the operation	2-25
(1) JOINT jog operation	2-29
(2) XYZ jog operation	2-31
(3) TOOL jog operation	2-33
(4) 3-axis XYZ jog operation	2-35
(5) CYLINDER jog operation	2-37
(6) Work jog operation	2-39
3 Installing the option devices	3-45
3.1 Installing the solenoid valve set (1S-VD0*(E)-02)	3-45
3.2 Installing the hand input cable	3-48
3.3 Installing the hand output cable	3-49
3.4 Changing the operating range	3-50
3.4.1 J1 axis	3-50
4 Basic operations	4-52
5 Maintenance and Inspection	5-53
5.1 Maintenance and inspection interval	5-53
5.2 Inspection items	5-54
5.2.1 Daily inspection items	5-54
5.2.2 Periodic inspection	5-55
5.3 Maintenance and inspection procedures	5-56
5.3.1 Robot arm structure	5-56
5.3.2 Installing/removing the cover	5-58
5.3.3 Inspection, maintenance and replacement of timing belt	5-60
(1) Timing belt replacement period	5-60

Contents

Page

(2) Inspection, maintenance and replacement of J4 axis timing belt (6-axis only)	5-61
(3) Inspection, maintenance and replacement of J5-axis timing belt	5-62
(4) Timing belt tension	5-63
5.3.4 Lubrication	5-64
(1) Lubrication position and specifications	5-64
(2) Lubrication method	5-65
5.3.5 Replacing the backup battery	5-66
(1) Replacing the robot arm battery	5-67
5.4 Maintenance parts	5-68
5.5 Resetting the origin	5-69
5.5.1 Mechanical stopper method	5-70
(1) J1 axis origin setting(mechanical stopper)	5-70
(2) J2 axis origin setting(mechanical stopper)	5-72
(3) J3 axis origin setting(mechanical stopper)	5-74
(4) J4 axis origin setting(6-axis type only)(mechanical stopper)	5-76
(5) J5 axis origin setting(mechanical stopper)	5-79
(6) J6 axis origin setting(mechanical stopper)	5-81
(7) All axis origin setting	5-83
5.5.2 Jig method	5-86
(1) J1 axis origin setting	5-87
(2) J2 axis origin setting	5-89
(3) J3 axis origin setting	5-91
(4) J4 axis origin setting (6-axis type only)	5-93
(5) J5 axis origin setting	5-95
(6) J6 axis origin setting	5-97
5.5.3 ABS origin method	5-99
(1) Select the T/B	5-100
5.5.4 User origin method	5-101
5.5.5 Recording the origin data	5-103
(1) Confirming the origin data label	5-103
(2) Confirming the origin data	5-103
(3) Recording the origin data	5-103
(4) Installing the cover	5-103
6Appendix	Appendix-104
Appendix 1 : Configuration flag	Appendix-104

1 Before starting use

This chapter explains the details and usage methods of the instruction manuals, the basic terminology and the safety precautions.

1.1 Using the instruction manuals

1.1.1 The details of each instruction manuals

The contents and purposes of the documents enclosed with this product are shown below. Use these documents according to the application.

For special specifications, a separate instruction manual describing the special section may be enclosed.

Safety Manual	Explains the common precautions and safety measures to be taken for robot handling, system design and manufacture to ensure safety of the operators involved with the robot.
Standard Specifications or special Specifications	Explains the product's standard specifications, factory-set special specifications, option configuration and maintenance parts, etc. Precautions for safety and technology, when incorporating the robot, are also explained.
Robot Arm Setup & Maintenance	Explains the procedures required to operate the robot arm (unpacking, transportation, installation, confirmation of operation), and the maintenance and inspection procedures.
Controller Setup, Basic Operation and Maintenance	Explains the procedures required to operate the controller (unpacking, transportation, installation, confirmation of operation), basic operation from creating the program to automatic operation, and the maintenance and inspection procedures.
Detailed Explanation of Functions and Operations	Explains details on the functions and operations such as each function and operation, commands used in the program, connection with the external input/output device, and parameters, etc.
Troubleshooting	Explains the causes and remedies to be taken when an error occurs. Explanations are given for each error No.
Additional axis function	Explains the specifications, functions and operations of the additional axis control.
Tracking Function Manual	Explains the control function and specifications of conveyor tracking.

Extended Function Instruction Manual

Explains the detailed description of data configuration of shared memory, monitoring, and operating procedures. SQ series only.

1.1.2 Terminological definition



Explain the term currently used in this manual.

- Robot controller The controller which controls the robot arm
It consists of the robot CPU system and the drive unit.(SQ series)
- Robot CPU (Unit) The CPU unit for the robots which installed to the sequencer base unit.
(Q3*DB) (SQ series)
- Robot CPU system Multi-CPU system. (SQ series)
It consists of MELSEC units, such as the sequencer base unit, the sequencer CPU unit, and the robot CPU unit, etc.
- Drive unit The box which mounts the servo amplifier for the robots, the safety circuit, etc. (SQ series)

1.1.3 Symbols used in instruction manual

The symbols and expressions shown in [Table 1-1](#) are used throughout this instruction manual. Learn the meaning of these symbols before reading this instruction manual.

Table 1-1 : Symbols in instruction manual

Terminology	Item/Symbol	Meaning
Item	The "Robot controller" or the "Controller"	Indicates the controller which controls the robot arm. Indicates the box which arranged control parts, such as robot CPU, servo amplifier, and the safety circuit.
Symbol	 DANGER	Precaution indicating cases where there is a risk of operator fatality or serious injury if handling is mistaken. Always observe these precautions to safely use the robot.
	 WARNING	Precaution indicating cases where the operator could be subject to fatalities or serious injuries if handling is mistaken. Always observe these precautions to safely use the robot.
	 CAUTION	Precaution indicating cases where operator could be subject to injury or physical damage could occur if handling is mistaken. Always observe these precautions to safely use the robot.
	[JOG]	If a word is enclosed in brackets or a box in the text, this refers to a key on the teaching pendant.
	[RESET] + [EXE] (A) (B)	This indicates to press the (B) key while holding down the (A) key. In this example, the [RESET] key is pressed while holding down the [+EXE] key.
	T/B	This indicates the teaching pendant.
	O/P	This indicates the operating panel on the front of the (drive unit).

1.2 Safety Precautions

Always read the following precautions and the separate "Safety Manual" before starting use of the robot to learn the required measures to be taken.

CAUTION

All teaching work must be carried out by an operator who has received special training. (This also applies to maintenance work with the power source turned ON.)
Enforcement of safety training

CAUTION

For teaching work, prepare a work plan related to the methods and procedures of operating the robot, and to the measures to be taken when an error occurs or when restarting. Carry out work following this plan. (This also applies to maintenance work with the power source turned ON.)
Preparation of work plan

WARNING

Prepare a device that allows operation to be stopped immediately during teaching work. (This also applies to maintenance work with the power source turned ON.)
Setting of emergency stop switch

CAUTION

During teaching work, place a sign indicating that teaching work is in progress on the start switch, etc. (This also applies to maintenance work with the power source turned ON.)
Indication of teaching work in progress

DANGER

Provide a fence or enclosure during operation to prevent contact of the operator and robot.
Installation of safety fence

CAUTION

Establish a set signaling method to the related operators for starting work, and follow this method.
Signaling of operation start

CAUTION

As a principle turn the power OFF during maintenance work. Place a sign indicating that maintenance work is in progress on the start switch, etc.
Indication of maintenance work in progress

CAUTION

Before starting work, inspect the robot, emergency stop switch and other related devices, etc., and confirm that there are no errors.
Inspection before starting work

1.2.1 Precautions given in the separate Safety Manual

The points of the precautions given in the separate "Safety Manual" are given below.
Refer to the actual "Safety Manual" for details.

DANGER

If the automatic operation of the robot is operated by two or more control equipment, design the right management of operation of each equipment of the customer.

CAUTION

Use the robot within the environment given in the specifications. Failure to do so could lead to a drop or reliability or faults. (Temperature, humidity, atmosphere, noise environment, etc.)

CAUTION

Transport the robot with the designated transportation posture. Transporting the robot in a non-designated posture could lead to personal injuries or faults from dropping.

CAUTION

Always use the robot installed on a secure table. Use in an instable posture could lead to positional deviation and vibration.

CAUTION

Wire the cable as far away from noise sources as possible. If placed near a noise source, positional deviation or malfunction could occur.

CAUTION

Do not apply excessive force on the connector or excessively bend the cable. Failure to observe this could lead to contact defects or wire breakage.

CAUTION

Make sure that the workpiece weight, including the hand, does not exceed the rated load or tolerable torque. Exceeding these values could lead to alarms or faults.

WARNING

Securely install the hand and tool, and securely grasp the workpiece. Failure to observe this could lead to personal injuries or damage if the object comes off or flies off during operation.

WARNING

Securely ground the robot and controller. Failure to observe this could lead to malfunctioning by noise or to electric shock accidents.

CAUTION

Indicate the operation state during robot operation. Failure to indicate the state could lead to operators approaching the robot or to incorrect operation.

WARNING

When carrying out teaching work in the robot's movement range, always secure the priority right for the robot control. Failure to observe this could lead to personal injuries or damage if the robot is started with external commands.

CAUTION

Keep the jog speed as low as possible, and always watch the robot. Failure to do so could lead to interference with the workpiece or peripheral devices.

CAUTION

After editing the program, always confirm the operation with step operation before starting automatic operation. Failure to do so could lead to interference with peripheral devices because of programming mistakes, etc.
Make sure that if the safety fence entrance door is opened during automatic operation, the door is locked or that the robot will automatically stop. Failure to do so could lead to personal injuries.

CAUTION

Never carry out modifications based on personal judgments, or use non-designated maintenance parts.
Failure to observe this could lead to faults or failures.

WARNING

When the robot arm has to be moved by hand from an external area, do not place hands or fingers in the openings. Failure to observe this could lead to hands or fingers catching depending on the posture.

⚠ CAUTION

Do not stop the robot or apply emergency stop by turning the robot controller's main power OFF.
If the robot controller main power is turned OFF during automatic operation, the robot accuracy could be adversely affected.

⚠ CAUTION

Do not turn off the main power to the robot controller while rewriting the internal information of the robot controller such as the program or parameters. If the main power to the robot controller is turned off while in automatic operation or rewriting the program or parameters, the internal information of the robot controller may be damaged.

⚠ DANGER

When the SSCNETIII cable is removed, install the cap in the connector.
If the cap is not installed, there is a possibility of malfunctioning by adhesion of the dust etc.

⚠ DANGER

Don't remove the SSCNETIII cable, when the power supply of the robot controller is turned on. Don't face squarely the light emitted from the tip of the SSCNETIII connector or the cable. If light strikes the eyes, there is a possibility of feeling the sense of incongruity for the eyes. (The light source of SSCNETIII is equivalent to the class 1 specified to JISC6802 and IEC60825-1.)

2 Unpacking to Installation

2.1 Confirming the product

The standard configuration of the robot arm, part of the purchased product, is shown in [Table 2-1](#).

Confirm the parts.

Users who have purchased optional products should refer to the separate "Standard Specifications".

Table 2-1 : Standard configuration

No.	Part name	Type	Qty.	Remarks
1	Robot arm	RV-3SQ/3SQJ series	Either 1 unit	
2	Guarantee card		1 copy	
3	Installation bolts	M8x35	4 pcs.	
4	Spring washer for installation bolts	For M8	4 pcs.	
5	Plain washer for installation bolts	For M8	4 pcs.	
6	Fixing plates		1 pcs.	This is installed in the robot arm at the time of shipment.
7	Fixing plates J1		1 pcs.	
8	Safety socket for suspension fitting	M4x10	1 pcs.	
9		M5x12	6 pcs.	
10	Plain washer for suspension fitting	For M5	6 pcs.	

2.2 Installation

2.2.1 Unpacking

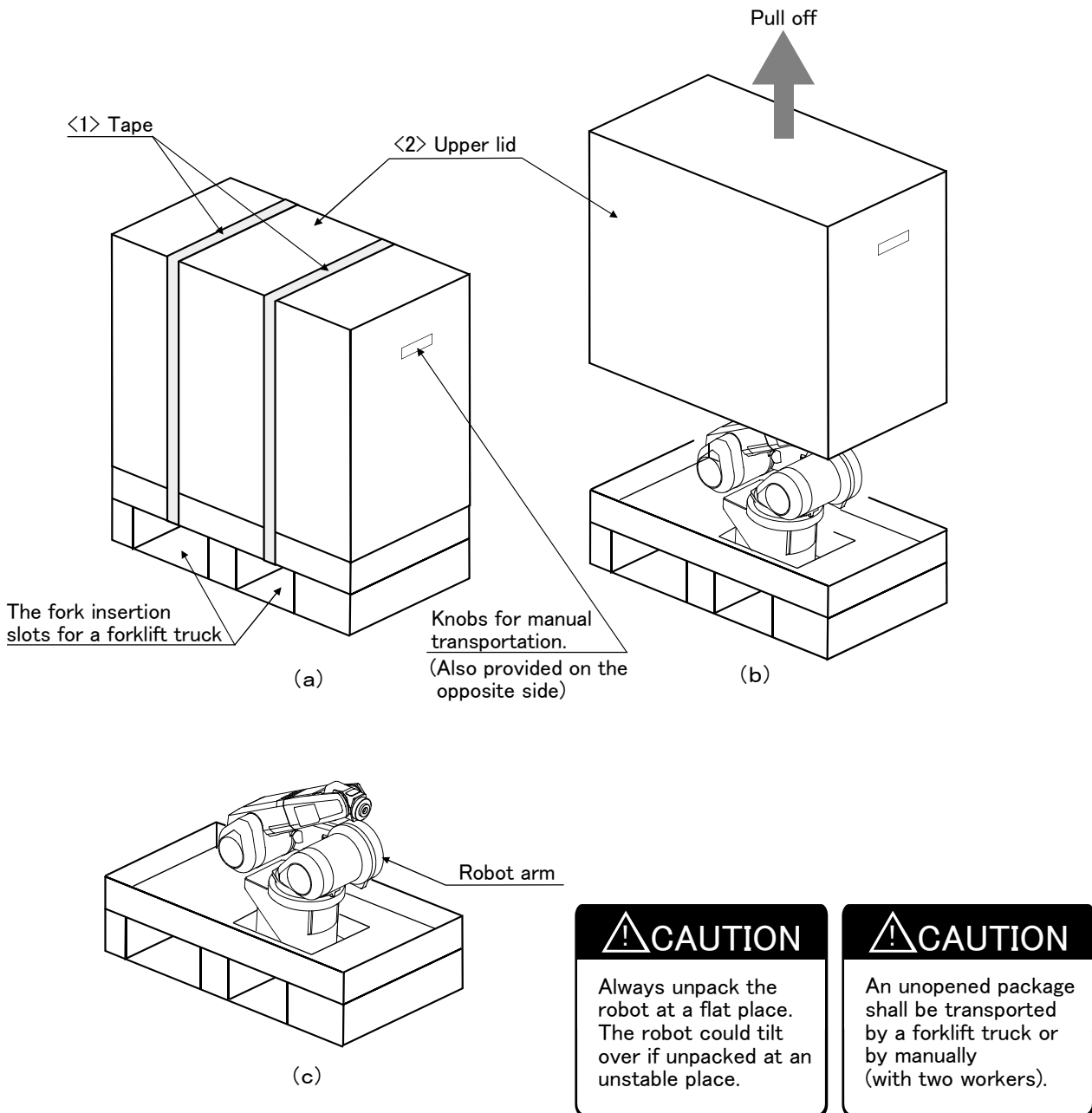

Fig.2-1 : Unpacking the robot arm

The robot is shipped from the factory in cardboard and plywood frame packing. Always refer to Fig. 2-1 and unpack the robot. Handle the robot arm according to "2.2.2 Transportation procedures(Transportation by people)".

The unpacking process is shown below.

- 1) Using a knife, etc., slit the tape <1> fixing the upper lid <2> of the cardboard box. (Fig. 2-1 (a))
- 2) Pull the upper lid <2> of the cardboard box off with both hands. (Fig. 2-1 (b))
- 3) Remove the hexagon socket bolts <3> (four positions) connecting the sleeper and the base unit. (Fig. 2-1 (c))
- 4) This completes the unpacking.

2.2.2 Transportation procedures(Transportation by people)

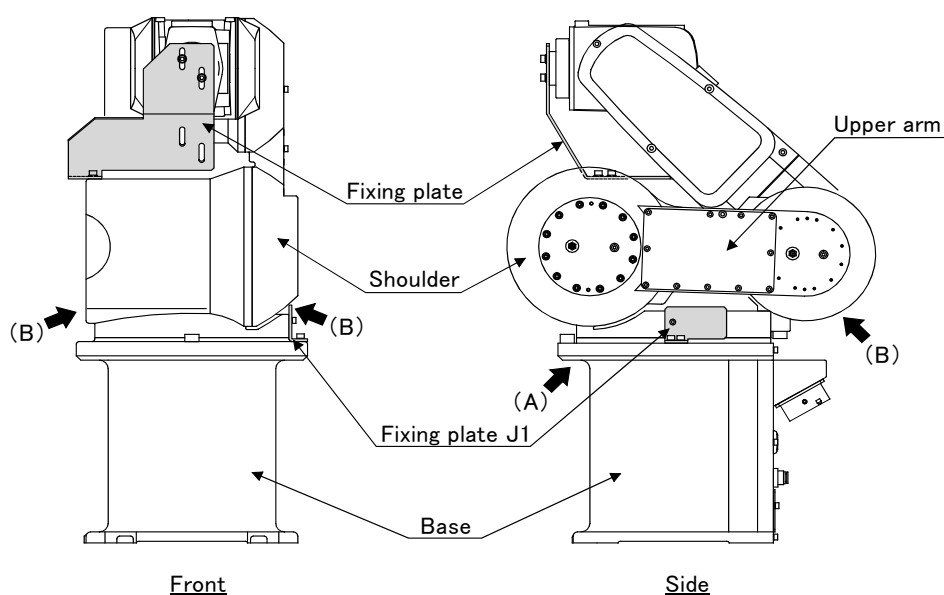

Mass
 RV-3SQJ series : Approx. 36kg
 RV-3SQJB series: Approx. 37kg

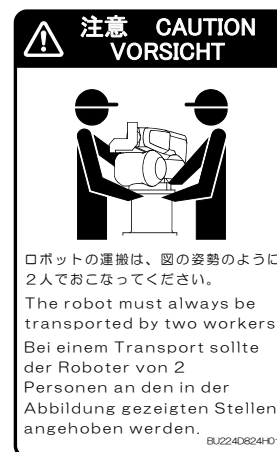
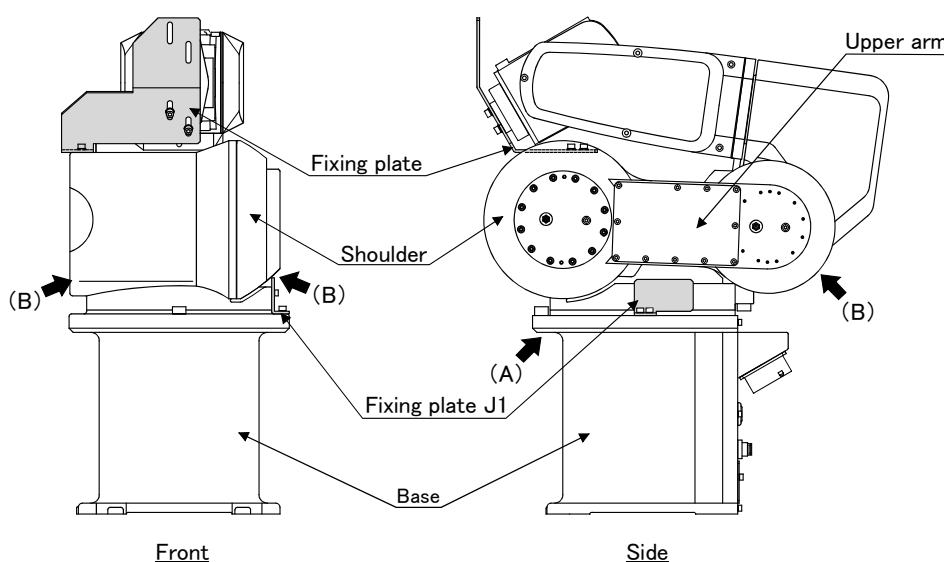

Fig.2-2 : Transportation of robot arm (Transportation by people: 5 axis)



Mass
 RV-3SQ series : Approx. 40kg
 RV-3SQB series: Approx. 41kg

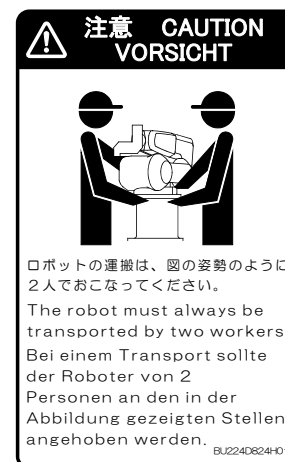

Fig.2-3 : Transportation of robot arm (Transportation by people: 6 axis)

- 1) The robot must be transported by two workers. Place the robot on a dolly, etc. and move it to the vicinity of the installation site.
- 2) When transporting the robot, workers should hold onto the base part (A) with one hand and the upper side of the upper arm area (B) with the other hand and face each other in such a way as to support the arm with their bodies and lift the robot.
Please be sure to avoid holding the robot from the front/back side or by the cover because the robot may tilt over and the cover may be damaged or dropped, which may lead to accidents.
- 3) When transporting the robot, do not apply force on the cover, or apply a strong impact on the robot
- 4) Always follow the above procedures and methods to transport the robot for secondary transportation, such as when changing the installation position. If the arm is directly suspended without using the specified suspension fittings, or if it is suspended in the work posture, the configuration devices could be damaged, and the transportation workers will be subject to risk due to an inadequate center of gravity position. (The robot cannot take the transportation pose by the stopper.)

**CAUTION**

To prevent accidents, do not hold the robot from the front/back sides, or hold covers that have no grips.

2.2.3 Installation procedures

The installation procedure of the robot arm is shown below.

- 1) The robot installation surface has been machine finished. Use the installation holes (4- $\phi 9$ holes) opened at the four corners of the base, and securely fix the robot with the enclosed installation bolts (M8 x 35 hexagon socket bolts).
- 2) Installation of the robot arm is a very important step for ensuring the optimum functions of the robot. Observe the following points when designing. Install the robot on a level surface.
- 3) It is recommended that the surface roughness of the table onto which the robot is to be installed by 6.3a or more. If the installation surface is rough, the contact with the table will be poor, and positional deviation could occur when the robot moves.

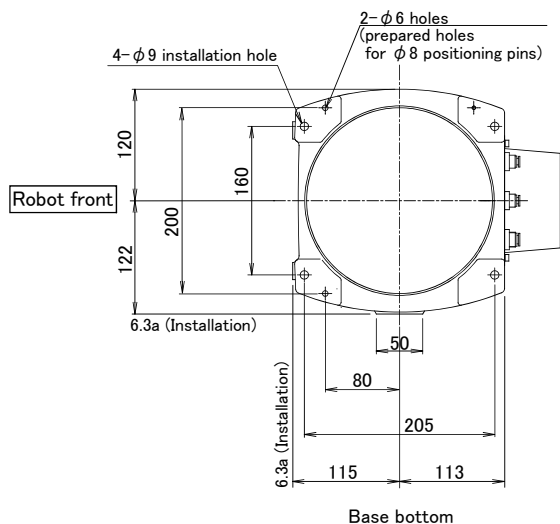
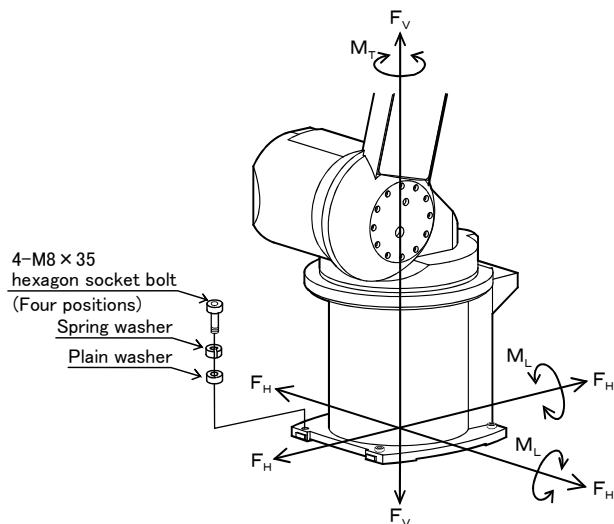



Fig.2-4 : Installation dimensions

Table 2-2 : Strength of the installation side (reference)

Item	Unit	Value
Falling moment : ML	N m	410
Twist moment : MT	N m	400
Horizontal translation power : FH	N	1,000
Vertical translation power : FV	N	1,200

- 4) When installing, use a common table to prevent the position of the devices and jigs subject to robot work from deviating.
- 5) The installation surface must have sufficient strength to withstand the arm reaction during operation, and resistance against deformation and vibration caused by the static (dynamic) load of the robot arm and peripheral devices, etc.
- 6) Remove the fixing plates after installing the robot.
- 7) When the robot is installed by hanging from the ceiling or on the wall, the MEGDIR parameter must be changed. For more information about parameters and how to change the parameters, refer to the separate "Instruction Manual/ Detailed Explanation of Functions and Operations".
- 8) The installation surface must have sufficient strength to withstand the arm reaction during moving the robot at high speed.
- 9) If you operate the robot at a high speed, reaction forces are applied to the installation stand by the robot's operation. Make sure that the installation stand on which the robot is placed has sufficient strength and rigidity. Table 2-2 shows the maximum reaction force (design values) that may be applied to an installation stand. Please use these values as reference when designing the installation stand.

 **CAUTION** Please secure the maintenance space required for connection of the machine cable, and exchange of the backup battery in the rear.

 **CAUTION** Please secure the maintenance space required for connection of the machine cable, and exchange of the backup battery in the rear side, and also space for J1 axis belt in the right side.

2.2.4 Grounding procedures

(1) Grounding methods

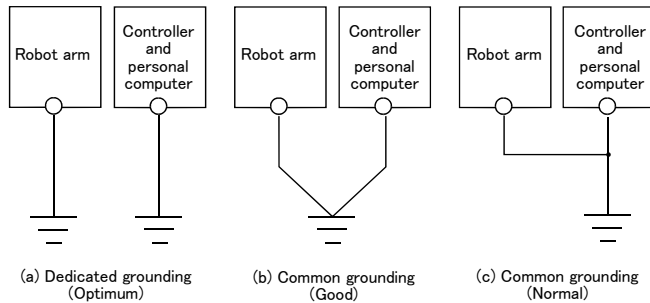

- 1) There are three grounding methods as shown in Fig. 2-5, but the dedicated grounding (Fig. 2-5 (a)) should be used for the robot arm and controller when possible. (Refer to the separate "Controller Setup, Basic Operation and Maintenance" for details on the controller grounding.)
- 2) Use Class D grounding (grounding resistance 100Ω or less). Dedicated grounding separated from the other devices should be used.
- 3) Use a AWG#11(3.5mm²) or more stranded wire for the grounding wire. The grounding point should be as close to the robot arm and controller as possible, and the length of the grounding wire should be short.

Fig.2-5 : Grounding methods

(2) Grounding procedures

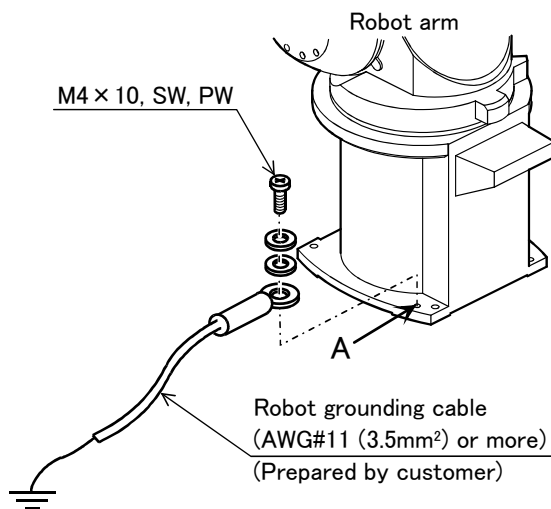

- 1) Prepare the grounding cable (AWG#11(3.5mm²) or more) and robot side installation screw and washer.
- 2) If there is rust or paint on the grounding screw section (A), remove it with a file, etc.
- 3) Connect the grounding cable to the grounding screw section.

Fig.2-6 : Connecting the grounding cable

2.2.5 Connecting with the controller

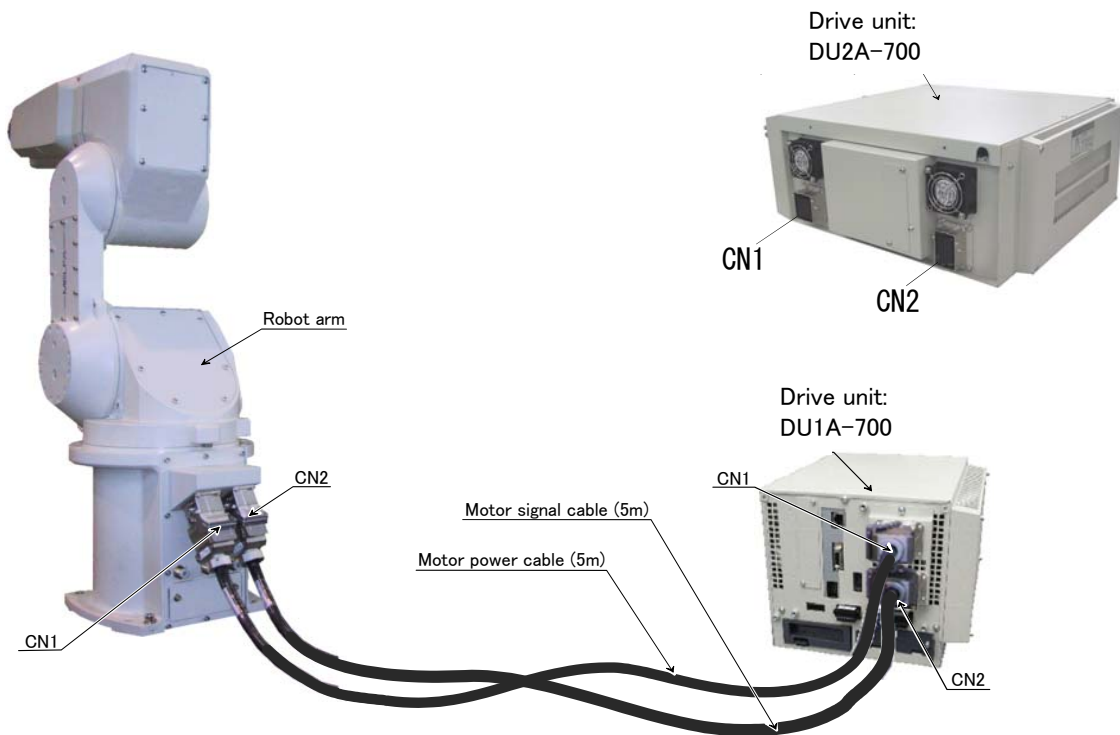
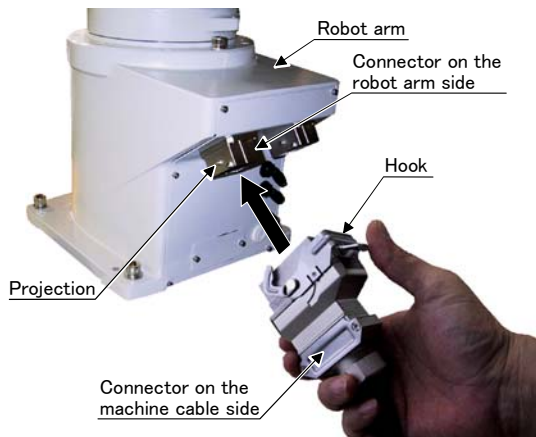

Fig.2-7 : Connecting the machine cables

Carry out the following procedure after installing the controller referring to the separate "Controller Setup, Basic Operation and Maintenance" manual.



1) Make sure that the power switch on the front of the controller is turned OFF.

2) Connect the machine cable to its corresponding connector on the robot arm side.

3) After connecting the connector, insert the hook attached to the connector on the machine cable side to the rear of the projection of the robot arm connector to fix securely in place.

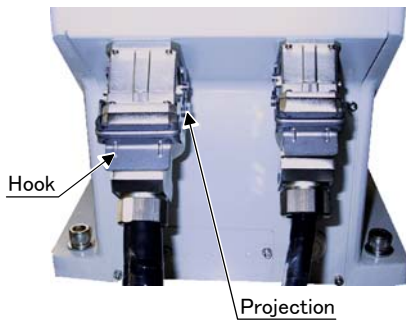

⚠ CAUTION Be careful not to get your hand pinched.



4) To remove the cable, insert a minus screwdriver into the hook while padding with a cloth, and remove the cable by lifting the hook.

⚠ CAUTION The machine cable connectors are dedicated for the controller side and robot arm side, so take special care when connecting. If connected incorrectly, the connector pins could bend or break. Thus, even if connected correctly, the robot will not operate correctly, creating a dangerous situation.

⚠ CAUTION Take special care to the leading of the connection cable. If the cable is pulled with force or bent excessively, wires could break or the connector could be damaged.

⚠ CAUTION Please be careful not to catch the hand at installation and removal.

2.3 Spare wiring

The interior of the spare wiring (AWG#24(0.2mm²) x4 pair (a total of eight cores) cab tire cable) is carried out to the robot arm from the base portion to the forehead arm side piece.

The customer can use this wire. In this case, the cable clamp (refer to the following) is needed separately for wiring leading about out of the robot. Please prepare of the customer in advance.

Table 2-3 : Incentive item of cable clamp

Type	Diameter of fit electric wire	Installation hole(mm)	Maker
OA-W1608	φ 6 ~ 8	φ 21	OHM ELECTRIC CO., LTD.

⚠ CAUTION

Do this work after turning OFF the power supply of the robot controller.

- 1) Remove safety socket (4) (M 4 x 8:4 bolts) which has stopped No.2 arm-cover C (3) or electromagnetic valve (5), and remove No.2 arm-cover C (3) or electromagnetic valve (5).

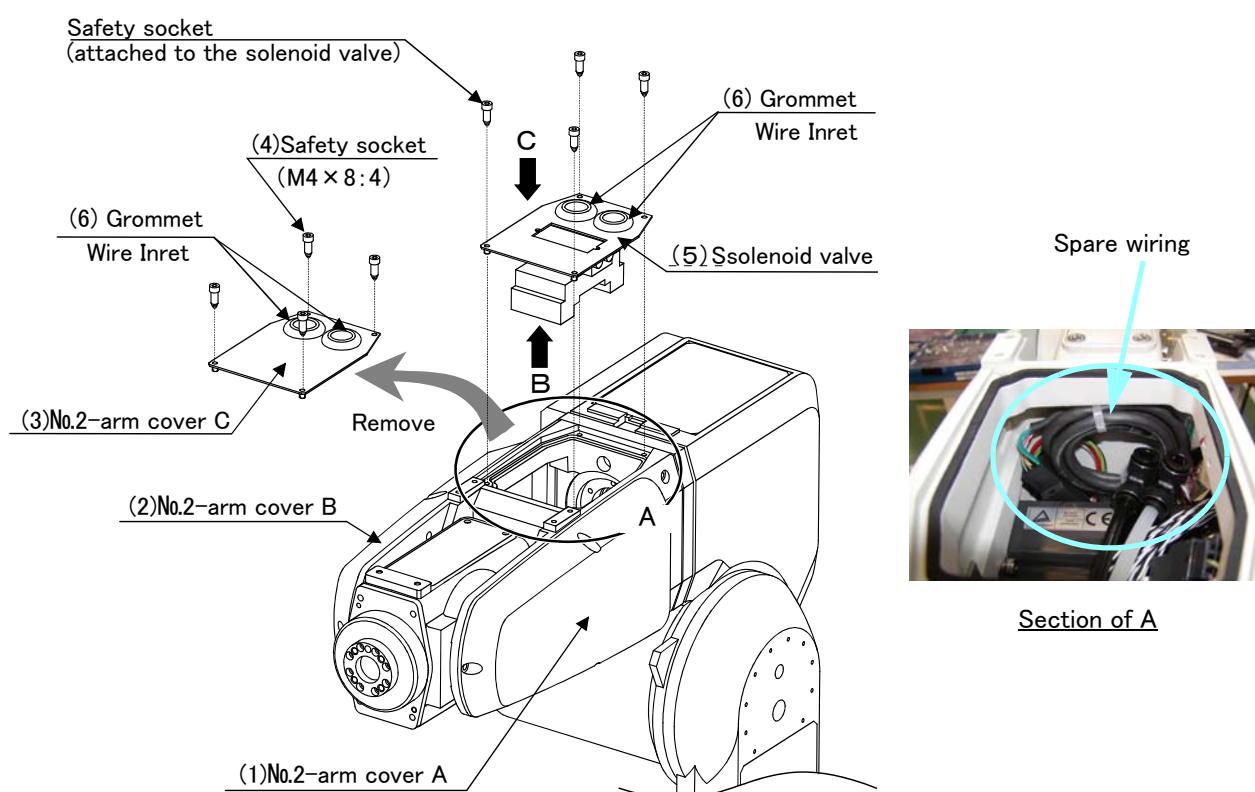

Fig.2-8 : Drawer of spare wiring (Fore arm side)

- 2) Take out the spare wiring (ADD) stored in the A section. (The spare wiring by the side of the fore arm is separable by the connector)
- 3) Since spare wiring is bundled in the union band, it removes the union band.
- 4) The connector is attached to spare wiring to both ends. Cut spare wiring near the connector (from the connector end to the about 10-20mm Refer to <figure-A> in Fig. 2-9), and let spare wiring pass to the cable clamp (customer preparation).
- 5) Remove one either among the grommets of No.2 arm cover C(3) or solenoid valve (5). After removing the grommet, the seal material which remained in the hole area of the sheet metal removes.
- 6) Remove the lock nut of attachment in the cable clamp.
- 7) Let the ADD connector side of spare wiring pass in the hole area of the cover, and surely fix with the lock nut.

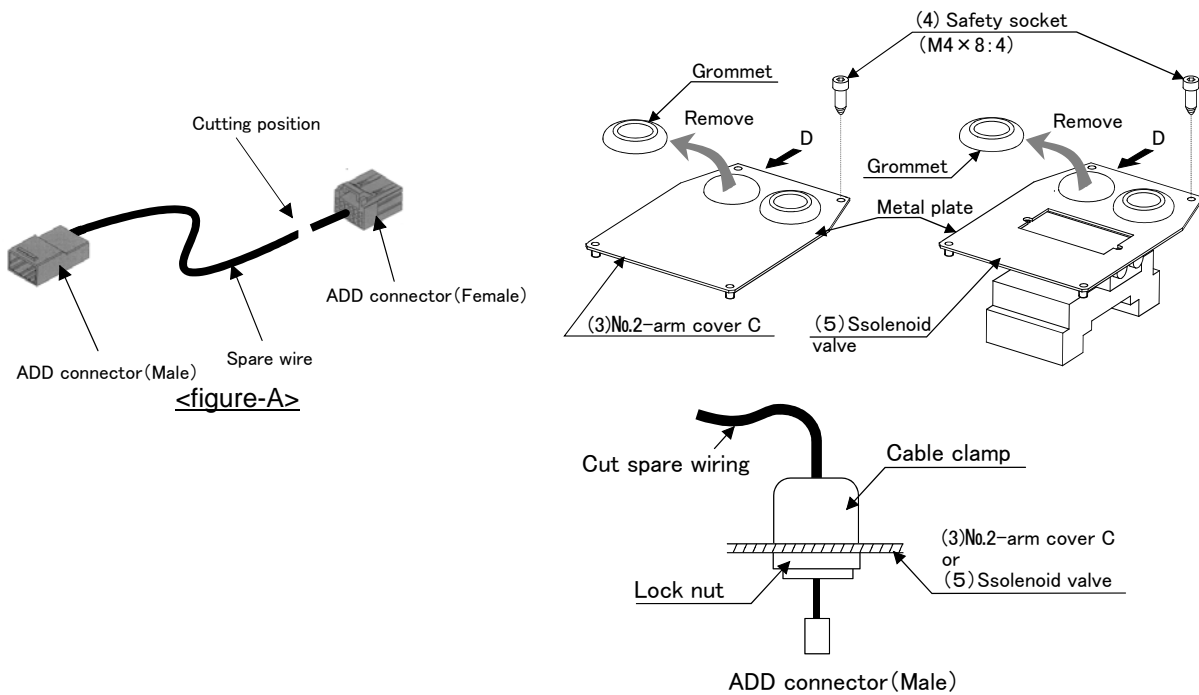

Fig.2-9 : Installation and connection of spare wiring

- 8) Connect "ADD" of the pulled-out spare wiring with the connector of "ADD" stored by the part A.
- 9) Install No.2 arm-cover C (3) or solenoid valve (5) as before. Be careful not to damage the seal material of the shape of the sponge pasting on "A section" If it damages, there is a possibility that protection specification may fall.
- 10) If the installation is completed, No.2 arm-cover B (2) will be installed as before. Be careful not to insert the cable

! CAUTION

When pulling out spare wiring, keep big power from being added to the cable, the air hose.

! CAUTION

Please check packing not being broken or not having stripped at the time of cover installing and removing. Please contact the dealer, if it is broken or has stripped. If you use it, packing broken or stripped, oil mist etc. will invade in the arm and will cause failure.

! CAUTION

When No.2 arm-cover C (3) or solenoid valve (5) are installed, please keep too much load from being applied to the cables inside the robot, and the air hoses. If too much load is added, the breaking of a wire and the air hose break, and the robot cannot operate normally.

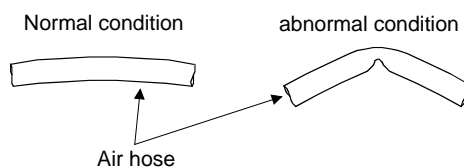

! CAUTION

When No.2 arm-cover C (3) or solenoid valve (5) are installed, catch neither the cable nor the air hose. If the bolt is tightened while it had been caught, the breaking of a wire and the air hose break, and the robot cannot operate normally. Moreover, packing does not stick and protection specification cannot be secured.

2.3.1 Base area

- 1) Remove installation bolt and remove CONBOX cover.

⚠ CAUTION

CONBOX cover is completely inseparable with the robot arm.

When you install and remove the cover, be careful of the cable etc. If too much power is applied, the robot may malfunction by the breaking of the cable.

- 2) Remove (1)ADD cover with reference to the "1.3.2 Installing/removing the cover" on page 50.
- 3) Take out spare wiring(ADD).
- 4) Remove the union band of spare wiring.
- 5) Cut spare wiring near the connector (from the connector end to the about 10–20mm. Refer to figure-A in Fig. 2-10)

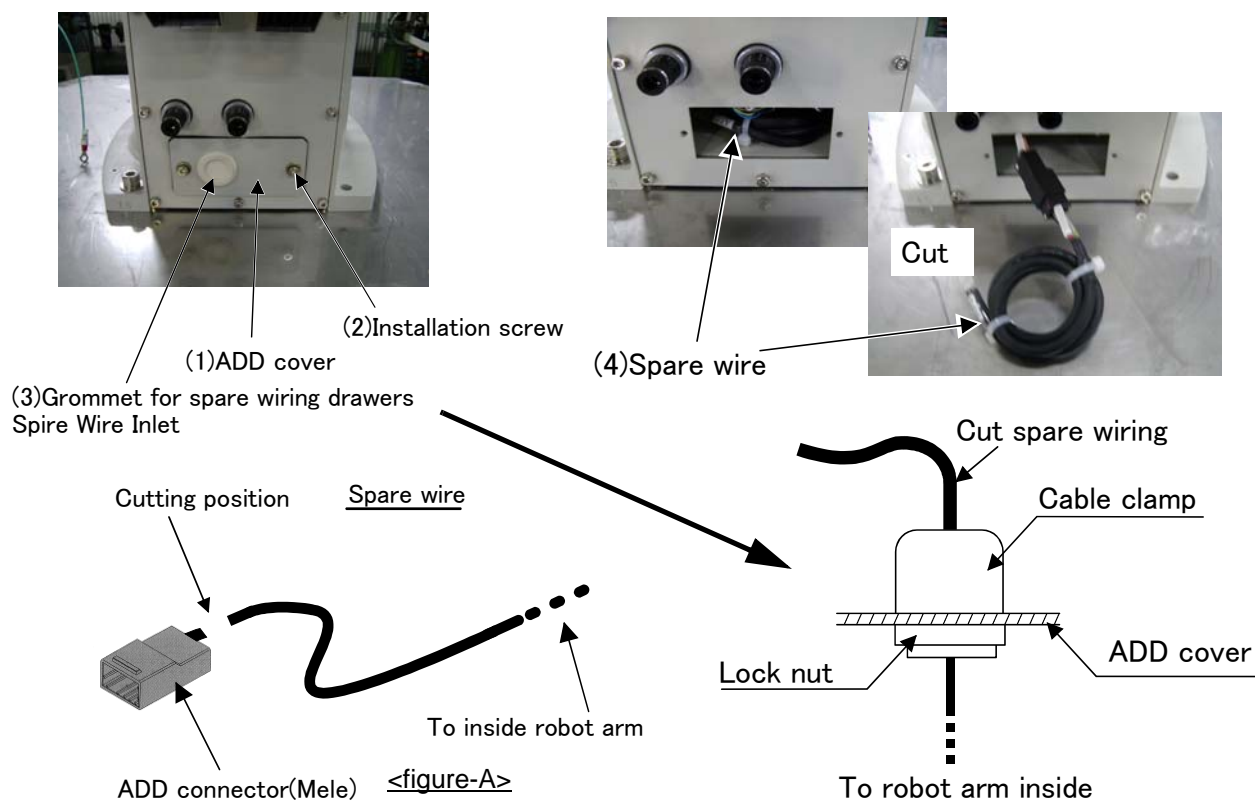

Fig.2-10 : Pull out spare wiring(Base area)

- 6) Remove the grommet of ADD cover (1). Remove the seal material which remained in the hole area of the metal plate .
- 7) Remove the lock nut of attachment in the cable clamp (customer preparation).
- 8) Let spare wiring pass from the robot arm side of ADD cover (1) in the hole after removing the grommet. Let the lock nut pass to spare wiring previously at this time.
- 9) The tip area of spare wiring pass to the cable clamp. And fix with the lock nut securely.
- 10) Install ADD cover as before. Be careful not to damage the seal material of the shape of the sponge pasting on "A section" If it damages, there is a possibility that protection specification may fall. Also be careful not to insert the cable

⚠ CAUTION

When pulling out spare wiring, keep big power from being added to the cable, the air hose.

⚠ CAUTION

Please check packing not being broken or not having stripped at the time of cover installing and removing. Please contact the dealer, if it is broken or has stripped. If you use it, packing broken or stripped, oil mist etc. will invade in the arm and will cause failure.

⚠ CAUTION

When "ADD cover (1)" is installed, please keep too much load from being applied to the cables and the air hoses. If too much load is applied, the cable will be broken, and robot and pneumatic drive equipment cannot operate normally.

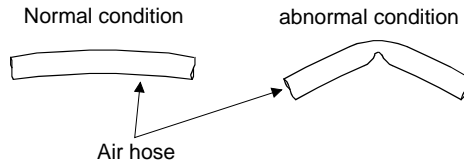

⚠ CAUTION

When "ADD cover (1)" is installed, catch neither the cable nor the air hose.
When No.2 arm-cover C (3) or solenoid valve (5) are installed, catch neither the cable nor the air hose.
If the bolt is tightened while it had been caught, the cable will be broken and the hose is bent, and the robot and pneumatic drive equipment cannot operate normally. Moreover, packing does not stick and protection specification cannot be secured.

2.3.2 Connection of piping for air pressurization

In use in oil mist environment, protection performance can be improved by pressurizing the inside of the robot arm. Please connect the $\phi 8$ air hose to the joint for pressurization of the robot arm base portion "AIR PURGE", and pressurize the inside of the robot arm.

Refer to the section of "Protection specification and the environment" of the "Standard specifications" separate volume.

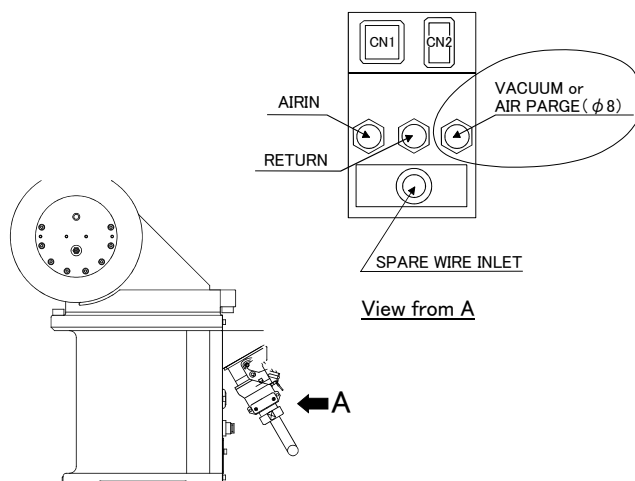

Fig.2-11 : Air purge

2.3.3 Connection of piping for suction

In use of the robot of clean specification, please connect the $\phi 8$ air hose to the joint for suction of the robot body base portion "VACUUM", and suck the inside of the robot body.

Refer to the section of "Clean specification" of the "Standard specifications" separate volume.

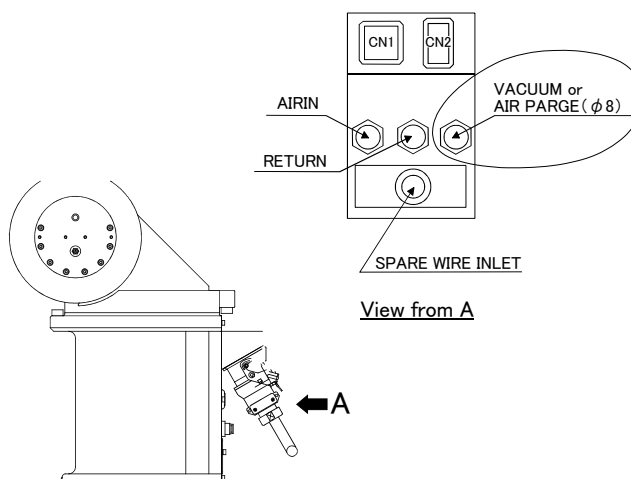

Fig.2-12 : Vacuum

2.4 Setting the origin

The origin is set so that the robot can be used with a high accuracy. After purchasing the robot, always carry out this step before starting work. This step must also be carried out if the combination of robot and controller being used is changed.

There are several methods for setting the origin, but the origin data input method will be explained here. Refer to "5.5 Resetting the origin" on page 55 for the other methods.

The teaching pendant is required for this operation.

[Caution] If the origin data at shipment is erased due to out of battery, it is necessary to set the origin again. Refer to "5.5 Resetting the origin" on page 55 and reset the origin using the jig method or ABS method.

2.4.1 Installing the teaching pendant (T/B)

When installing and removing the T/B, turn off the controller power supply. If T/B is installed or removed in the state of power supply ON, emergency stop alarm will occur.

If you use the robot wherein T/B is removed, please install the attached dummy connector. With the connector, put the dummy connector or draw it out.



CAUTION

Please do not pull the cable of T/B strongly or do not bend it too much.

It becomes the breaking of a wire of the cable and the cause of breakage of the connector. Please installing and removing so that stress does not start the cable with the connector itself.

Explain the installation method of T/B below.

- 1) Check that the POWER (power supply) switch of the robot controller is OFF.
- 2) Connects T/B connector to the robot controller. Use as the upper surface the lock lever shown in Fig. 2-13, and push in until there is sound.

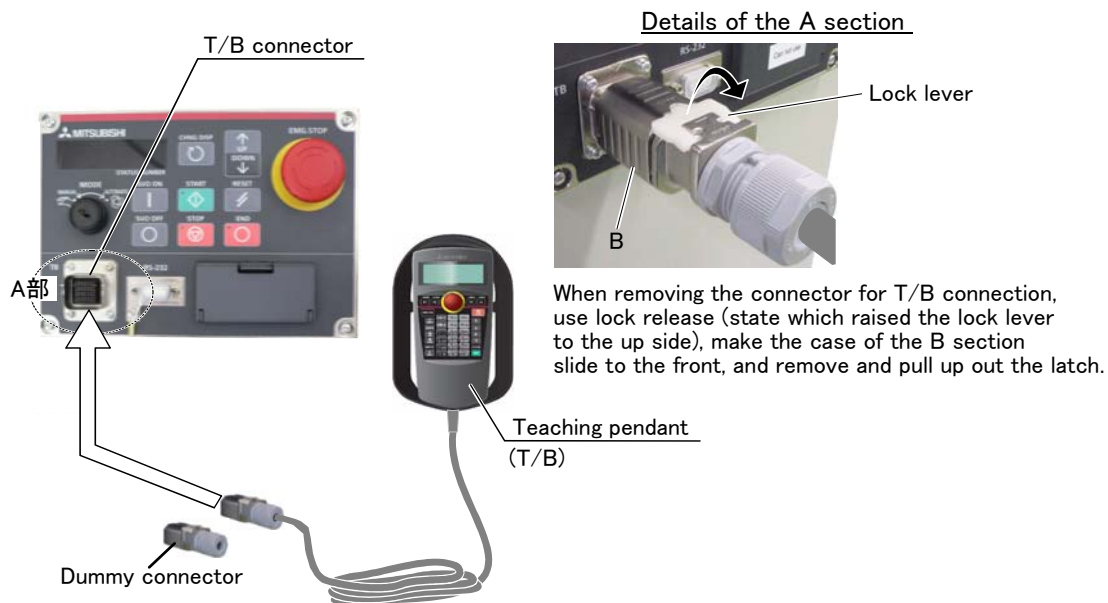

Fig.2-13 : Installing and removing the T/B

The installation of T/B is finished.

◆◆◆ If error C0150 occurs ◆◆◆

At the time of the first power supply injection, error:C0150 (the serial number of the robot arm has not been set up) occur the robot after purchase.

Parameter: Please input the serial number of the robot body into RB SERIAL. Refer to "instructions manual / controller setup, and basic operation & maintenance" for the operation method.

2.4.2 Setting the origin with the origin data input method

(1) Confirming the origin data

● Origin data history table (Origin Data History) Serial No.ES804008

Date	Default
D	V!#S29			
J 1	06DTYY			
J 2	2?HL9X			
J 3	1CP55V			
J 4	T6!M\$Y			
J 5	Z2IJ%Z			
J 6	A12%Z0			
Method	E	E · N · S P	E · N · S P	E · N · S P

(O: O(Alphabet), 0: Zero)

Note) Meanings of symbols in method column

E: Jig method

N: Not used

SP: Not used

The origin data to be input is noted in the origin data sheet enclosed with the arm, or on the origin data history table attached to the back side of the shoulder cover A.. (Refer to [Fig. 2-14](#)).

Referring to “[5.3.2 Installing/removing the cover](#)” on page 42, remove the shoulder cover A and confirm the value.

The value given in the default setting column is the origin settings set with the calibration jig before shipment.

Note that the 5-axis type does not have the J4 axis.

Fig.2-14 : Origin data label (an example)

* The origin data to input is found on also the robot examination report sheet.

**WARNING**

Always install/remove the cover with the controller control power turned OFF. Failure to do so could lead to physical damage or personal injury should the robot start moving due to incorrect operations.

(2) Turning ON the control power

**CAUTION**

Confirm that there are no operators near the robot before turning the power ON.

1) Turn the controller [POWER] switch ON.

The control power will be turned ON, and “o. 100” will appear on the STATUS NUMBER display on the front of the controller.

(3) Preparing the T/B



Next, prepare to use the T/B

1) Set the [MODE] switch on the front of the controller to "MANUAL".

2) Set the T/B [ENABLE] switch to "ENABLE". The menu selection screen will appear.

The following operations are carried out with the T/B.

◆◆◆ Operating from the T/B ◆◆◆

Always set the [MODE] switch (mode selection key switch) on the front of the controller to "MAMNUAL", and then set the T/B [ENABLE] switch to "ENABLE".

When the T/B is valid, only operations from the T/B are possible. Operations from the controller or external signals will not be accepted.

(4) Selecting the origin setting method

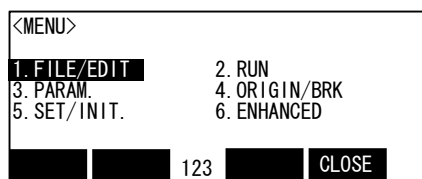

1) Press the [4] key on the menu screen, and display the ORIGIN/BRAKE screen.

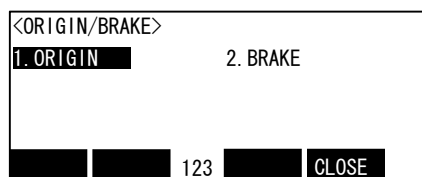

2) Press the [1] key on the ORIGIN/BRAKE screen, and display the origin setting method selection screen.

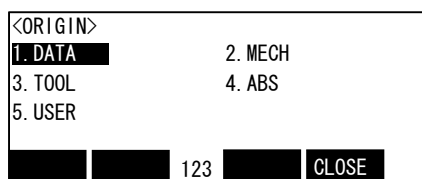

3) Press the [1] key on the origin setting method selection screen, and select the data input method.

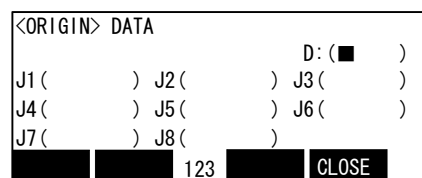

4) Display the origin data input screen

◆◆◆ Selecting a menu ◆◆◆

The menu can be selected with one of the following methods.

A: Press the numeral key for the No. of the item to be selected.

B: Using the [↓] and [↑] keys, etc., move the cursor to the item to be selected, and then press the [INP] key.

◆◆◆ The input method of numeral ◆◆◆

The number can be inputted if the key displayed on the lower left of each key is pressed. Press the

[CHARACTER] key, and in the condition that "123" is displayed on the screen lower side, press the number key.

(5) Inputting the origin data



Input the value confirmed in section “(1) Confirming the origin data” on page 20.

The correspondence of the origin data label value and axis to be input is shown in Fig. 2-15. (For the 5-axis robot, the J4 axis is meaningless.)

Fig.2-15 : Correspondence of origin data label and axis

The method for inputting the origin data is explained below. The value shown in Fig. 2-14 will be input as an example.

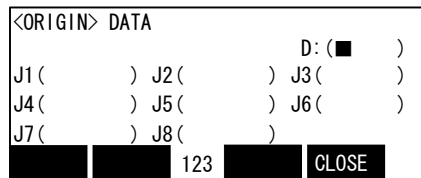

1) Confirm that the cursor is at the “D” position on the T/B display screen.

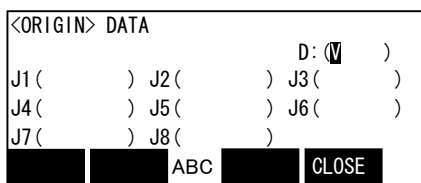

CHARACTER

-B (J5)
8 TUV

2) Input the D value “V!%S29”.

Inputting “V”

Press the [CHARACTER] key and set to the character input mode. (Condition that “ABC” was displayed under the screen)

Press the [TUV] key three times. “V” will be set.

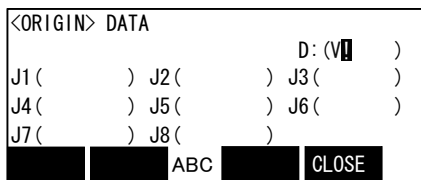

+C (J6)
. , %

→

+C (J6)
. , %

Inputting “!”

Press the [, %] key five times. “!” will be set.

Press the [→] key once and advance the cursor.

Press the [, %] key twice (input “%”), and press the [PQRS] key four times (input “S”).

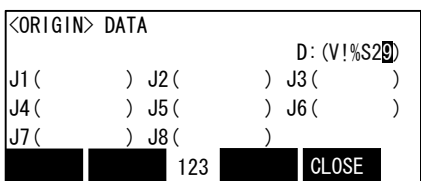

CHARACTER

-Z (J3)
2 ABC

+B (J5)
9 WXYZ

Press the [CHARACTER] key and set to the numeral input mode. (Condition that “123” was displayed under the screen)

Press the [2] key (input “2”), and press the [9] key (input “9”).

“V!%S29” will appear at the “D” data on the teaching pendant screen.

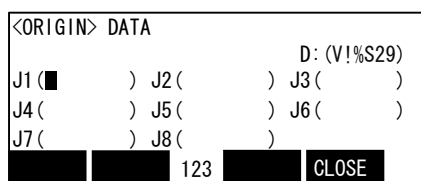

↓

3) Press the [↓] key, and move the cursor to the J1 input position.

4) Input the J1 value in the same manner as above.

Input the J2, J3, J4, J5 and J6 values in the same manner. Note that the J4 axis is not required for the 5-axis type.

<ORIGIN> DATA				D: (V!%S29)
J1 (06DTYY)	J2 (2?HL9X)	J3 (1CP55V)		
J4 (T6!MSY)	J5 (Z21J%Z)	J6 (A12%Z0)		
J7 ()	J8 ()			
ABC	CLOSE			

EXE

<ORIGIN> DATA			
CHANGE TO ORIGIN. OK?			
Yes	123	No	

F1

5) After inputting all of the values, press the [EXE] key. The origin setting confirmation screen will appear.

6) Press [F1] (Yes) to end the origin setting

◆◆◆ Moving the cursor ◆◆◆

Press the [↑], [↓], [←] and [→] keys.

◆◆◆ Inputting characters ◆◆◆

Press the [CHARACTER] key and set to the character input mode. (Condition that "ABC" was displayed under the screen). The displayed character is scrolled each time at pressing the key.

◆◆◆ Correcting an input ◆◆◆

After returning one character by pressing the [C L E A R] key, input the character again.

(6) Installing the shoulder cover A.

Return the shoulder cover A removed in section "(1) Confirming the origin data" on page 20 to its original position.

This completes the setting of the origin with the origin data input method.



WARNING

Always remove and install the cover with the controller power turned OFF. Failure to do so could lead to the robot moving because of incorrect operations, or to physical damage or personal injury.

◆◆◆ If the origin input data is incorrect ◆◆◆

If the origin input data is incorrect, the alarm No. 1760 (origin setting data illegal) will occur when origin data input. In this case, reconfirm the value input for the origin data.

2.5 Confirming the operation

In this section, the robot will be moved manually using the T/B to confirm that the operation is correct. Moving the robot manually is called "jog operation". This operation includes the JOINT jog that moves each axis, the XYZ jog that moves along the base coordinate system, the TOOL jog that moves along the tool coordinate system, and the CYLINDER jog that moves along the circular arc.

This operation is carried out while pressing the deadman switch on the back of the T/B.

CAUTION The robot will move during this operation. Make sure that there are no operators near the robot, and that there are no obstacles, such as tools, in the robot operation range.

CAUTION To immediately stop the robot, release the deadman switch on the back of the T/B. The servo power will turn OFF, and the robot will stop. The robot will also stop if the [EMG.STOP] switch (emergency stop switch) on the front of the T/B or the [EMG.STOP] switch (emergency stop) on the front of the controller is pressed.

WARNING Confirm that the origin has been set. If the origin has not been set, "****" will appear at the current position display on the teaching pendant, the JOINT jog operation will take place in any jog mode selected. Refer to "2.4 Setting the origin" on page 19 for details on setting the origin.

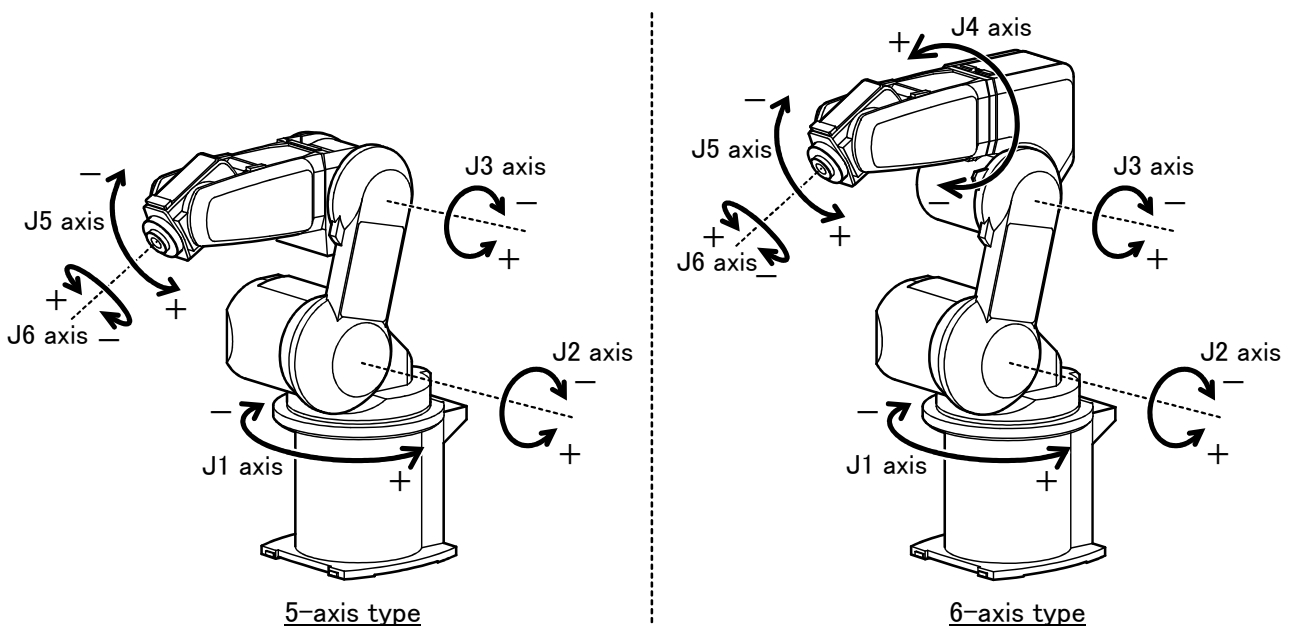

* Each axis moves independently.
The 5-axis type does not have the J4 axis.

Fig.2-16 : JOINT jog operation

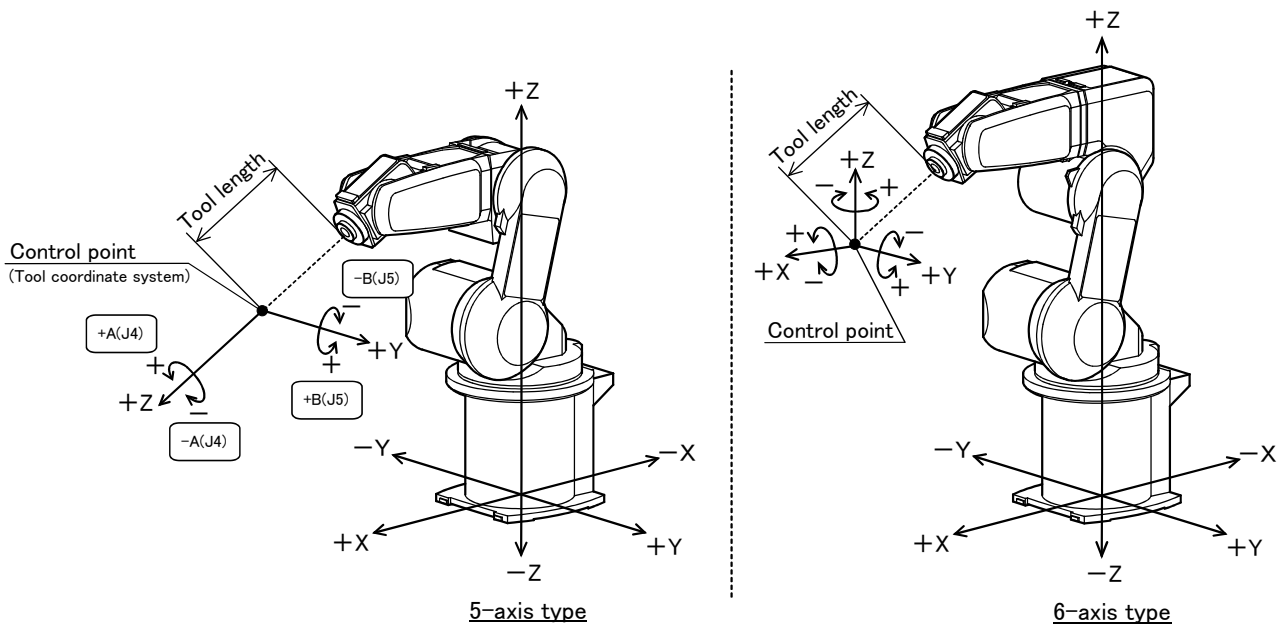

* While maintaining the flange surface posture, the axis moves straight along the base coordinate system. Also, while maintaining the control point position, the flange surface posture changes.

Fig.2-17 : XYZ jog operation

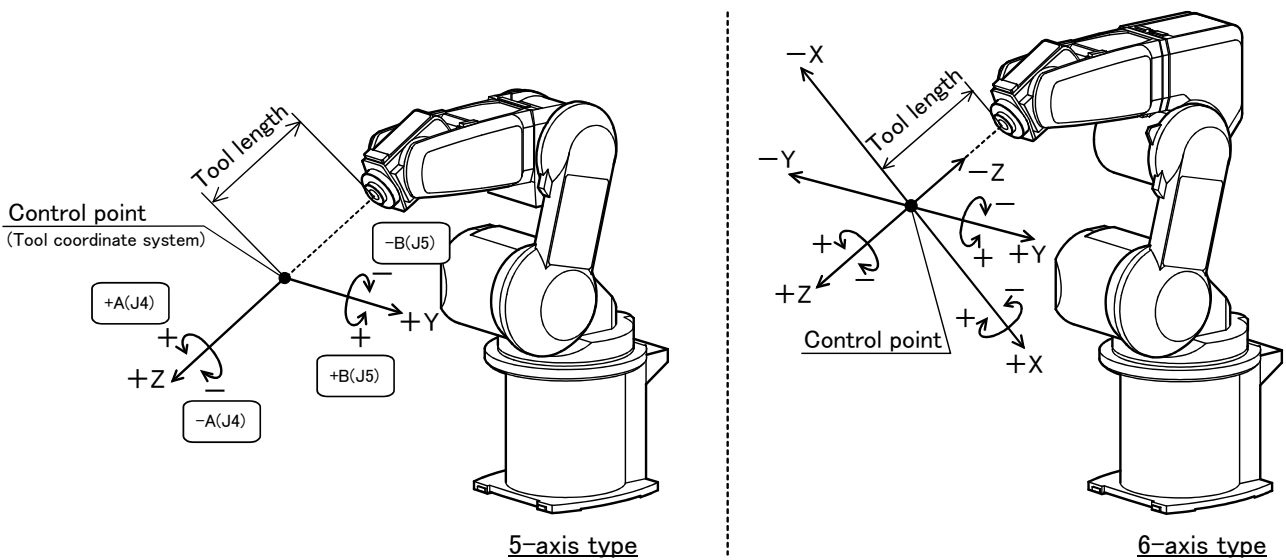

* While maintaining the flange surface posture, the axis moves straight along the tool coordinate system. Also, while maintaining the control point position, the flange surface posture changes. With the 5-axis type, the axis moves only in the X and Y axis directions of the tool coordinates.

Fig.2-18 : TOOL jog operation

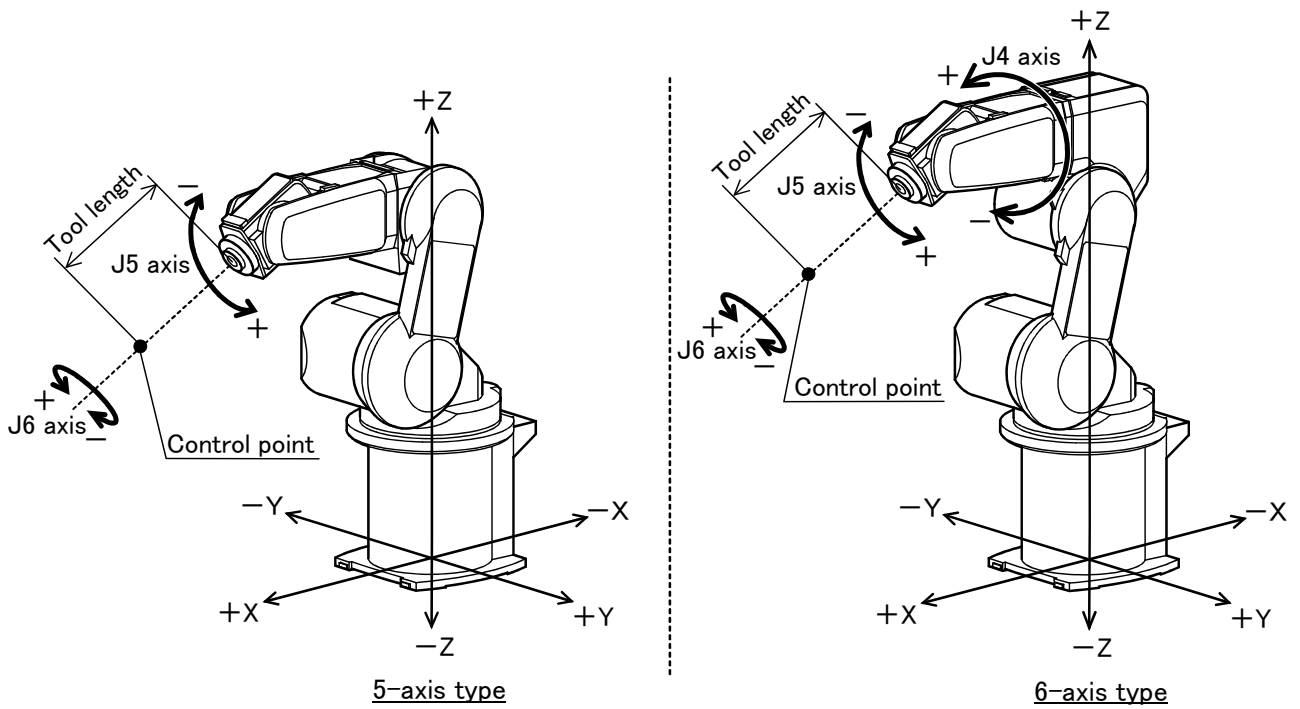

* The axis moves straight along the base coordinate system. At this time, the flange surface posture is not maintained. Also, the flange surface posture changes. The flange surface position changes at this time.

Fig.2-19 : 3-axis XYZ jog operation

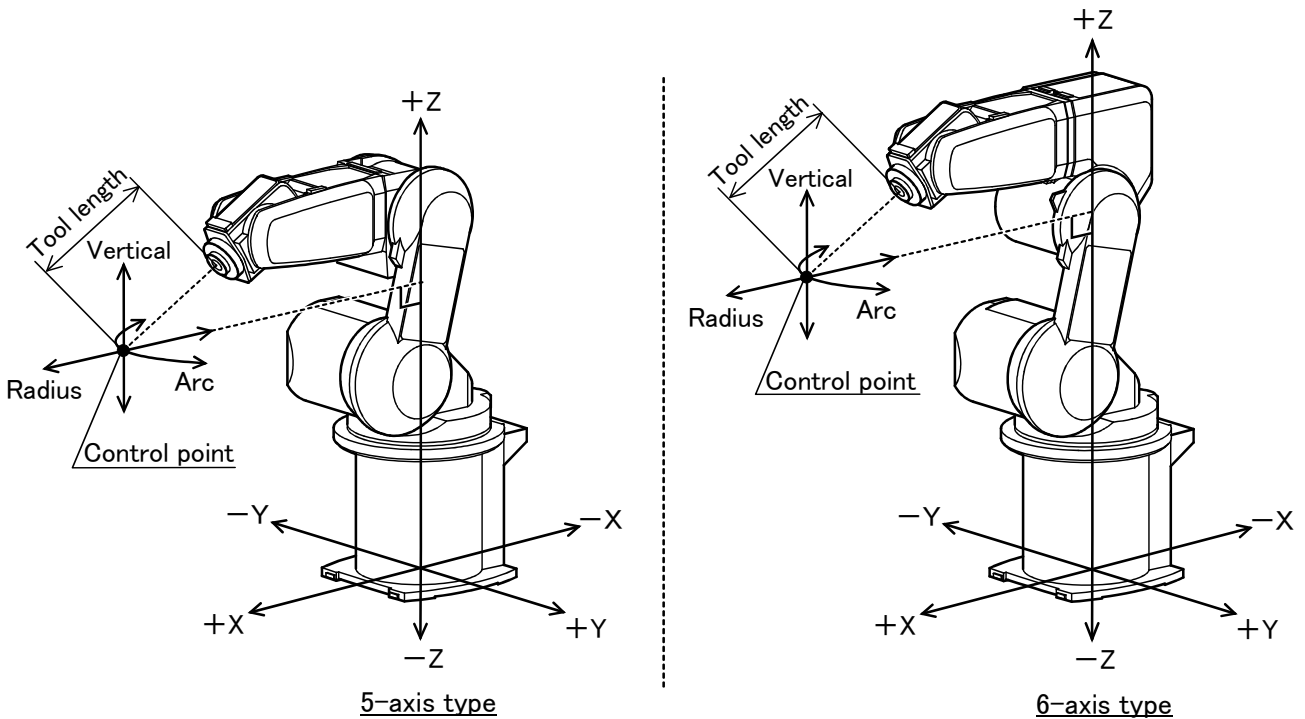

* The current position is set as the arc centering on the Z axis, and the axis moves along that arc, expands and contracts in the radius direction, and moves vertically. At this time, for the 6-axis type, the flange surface posture is maintained. Also, while maintaining the control point position, the flange surface posture changes.

Fig.2-20 : CYLINDER jog operation

(1) JOINT jog operation

Select joint jog mode

<CURRENT>	JOINT	100%	M1	TO
J1:	+0.00	J5:	+0.00	
J2:	+0.00	J6:	+0.00	
J3:	+90.00	:		
J4:	+0.00	:		

XYZ TOOL JOG **3-XYZ** CYLNDR =>

Joint jog mode

JOG F1

Set jog speed

<CURRENT>	JOINT	100%	M1	TO
J1:	+0.00	J5:	+0.00	
J2:	+0.00	J6:	+0.00	
J3:	+90.00	:		
J4:	+0.00	:		

XYZ TOOL JOG **3-XYZ** CYLNDR =>

Setting the speed

OVRD ↑ OVRD ↓

[JOG] Press the key and display the jog screen. ("JOG" is displayed on the screen bottom)

Check that the "joint" in jog mode is displayed on the screen.

If other jog modes are displayed, please press the function key corresponding to the "joint." (If the jog mode which he wishes under the screen is not displayed, it is displayed that the [FUNCTION] key is pressed)

If it finishes jog operation, press the [JOG] key again, or function key which correspond to "close."

Whenever it presses the key of [OVRD ↑], the override goes up. Conversely, if the [OVRD ↓] key is pressed, it will go down.

The current setting speed is displayed on screen upper right, and "STATUS NUMBER" of the controller.

Set the override to 10% here for confirmation work

J1 axis jog operation

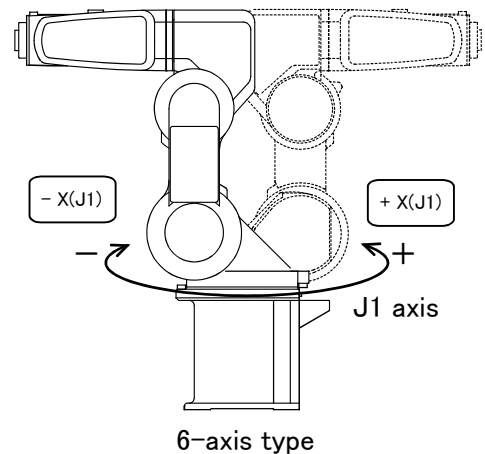
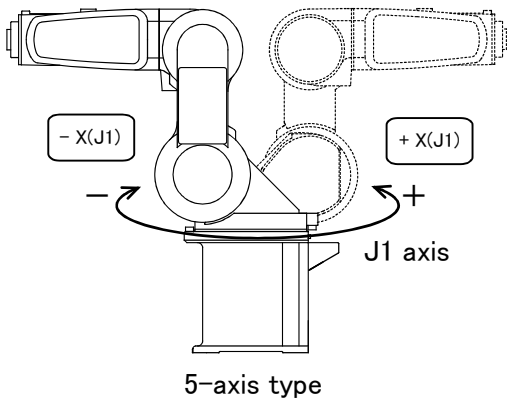

- When the [+X (J1)] keys are pressed, the J1 axis will rotate in the plus direction. When the [-X (J1)] keys are pressed, Rotate in the minus direction.

J2 axis jog operation

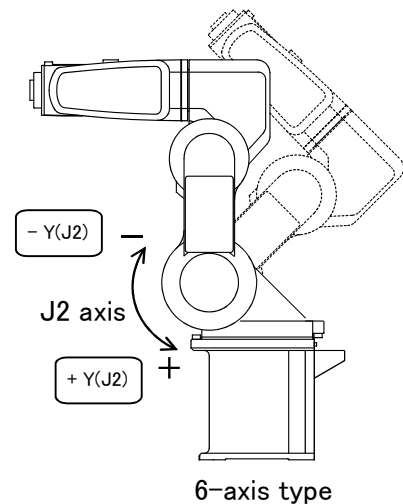
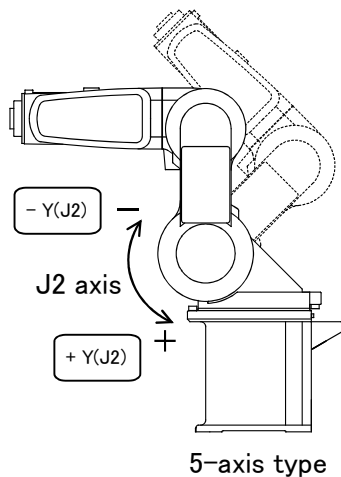

- When the [+Y (J2)] keys are pressed, the J2 axis will rotate in the plus direction.
When the [-Y (J2)] keys are pressed, Rotate in the minus direction.

◆◆◆ When the robot is in the transportation posture ◆◆◆

The axes may be outside the movement area. Move these axes toward the inner side of the movement area.

J3 axis jog operation

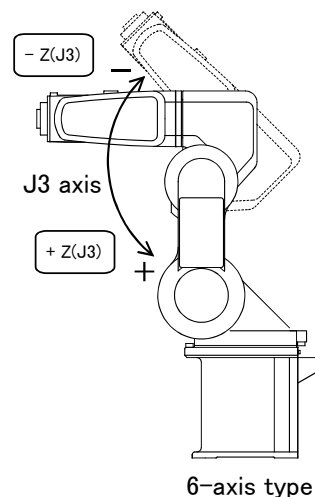
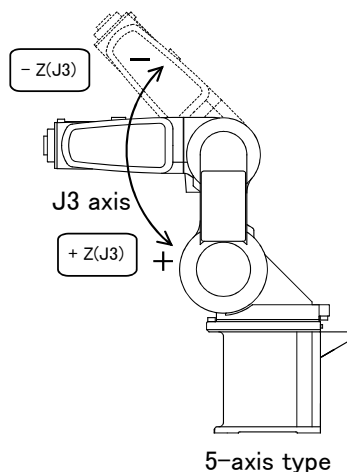

- When the [+Z (J3)] keys are pressed, the J3 axis will rotate in the plus direction.
When the [-Z (J3)] keys are pressed, Rotate in the minus direction.

J4, J5 and J6 axis jog operation

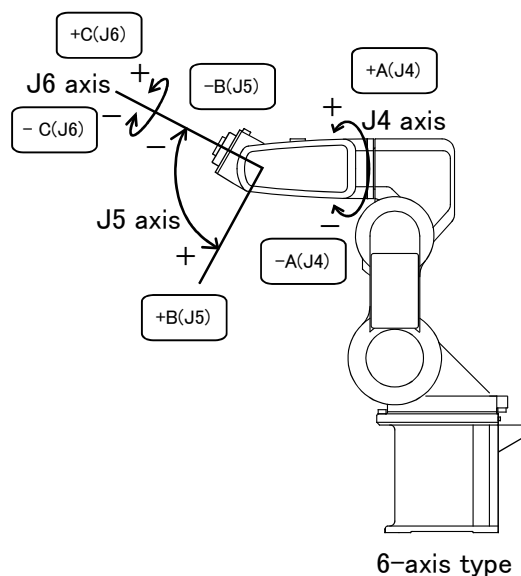
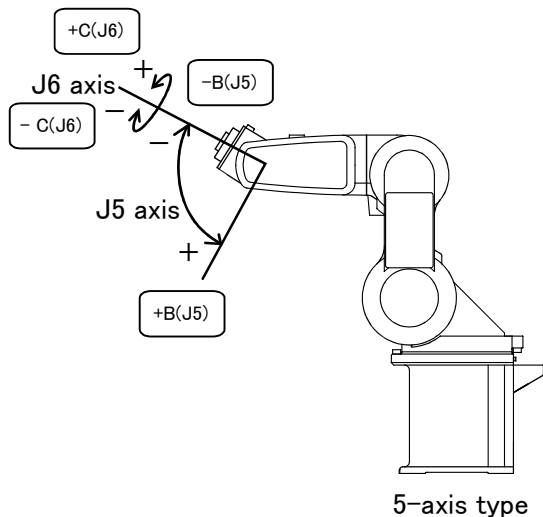

- When the [+A (J4)] keys are pressed, the J4 axis will rotate in the plus direction.
When the [-A (J4)] keys are pressed, Rotate in the minus direction. (6-axis type only)
- When the [+B (J5)] keys are pressed, the J5 axis will rotate in the plus direction
When the [-B (J5)] keys are pressed, Rotate in the minus direction.
- When the [+C (J6)] keys are pressed, the J6 axis will rotate in the plus direction
When the [-C (J6)] keys are pressed, Rotate in the minus direction.

◆◆◆ If the buzzer of T/B sounds and the robot does not move ◆◆◆

If it is going to move the robot across the operation range, the buzzer of T/B sounds and the robot does not move. In this case, please move to the counter direction.

(2) XYZ jog operation

Select XYZ jog mode

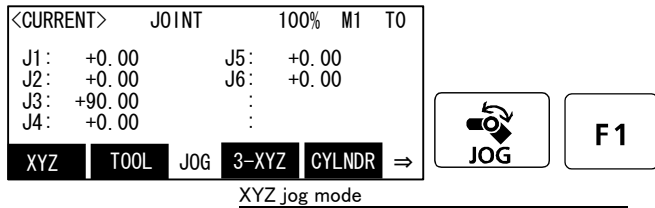

Set jog speed

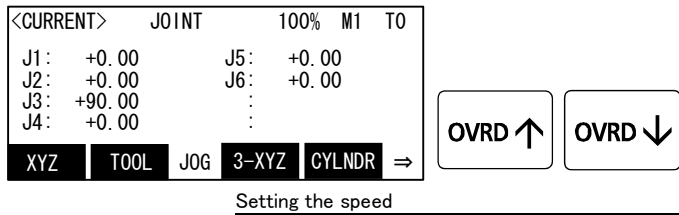

[JOG] Press the key and display the jog screen. ("JOG" is displayed on the screen bottom)

Check that the "XYZ" in jog mode is displayed on the screen.

If other jog modes are displayed, please press the function key corresponding to the "XYZ." (If the jog mode which he wishes under the screen is not displayed, it is displayed that the [FUNCTION] key is pressed)

If it finishes jog operation, press the [JOG] key again, or function key which correspond to "close."

Whenever it presses the key of [OVRD ↑], the override goes up. Conversely, if the [OVRD ↓] key is pressed, it will go down.

The current setting speed is displayed on screen upper right, and "STATUS NUMBER" of the controller.

Set the override to 10% here for confirmation work

Moving along the base coordinate system

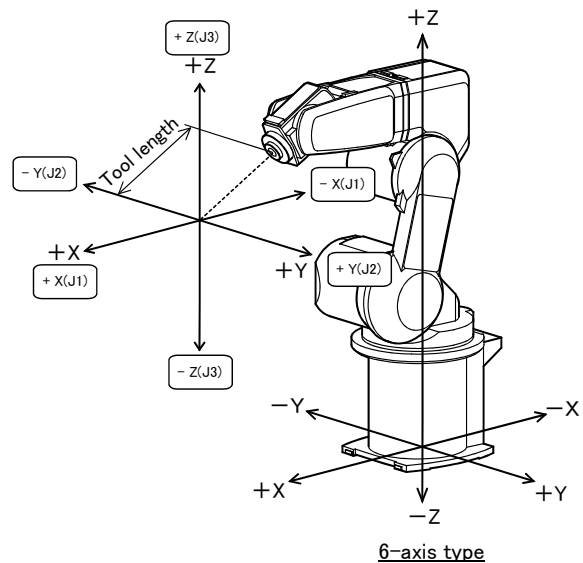
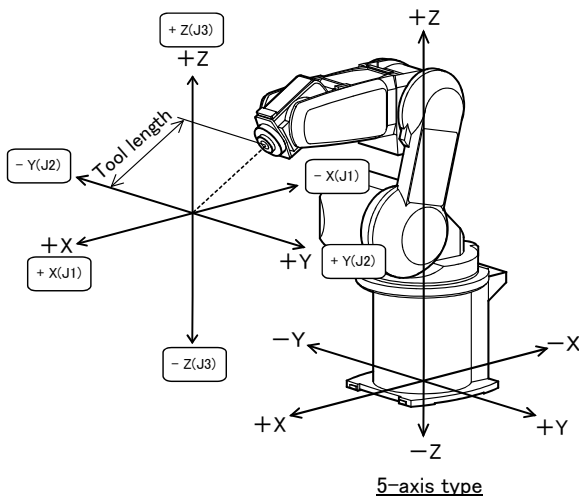

* The direction of the flange will not change

- When the [+X (J1)] keys are pressed, the robot will move along the X axis plus direction. When the [-X (J1)] keys are pressed, Move along the minus direction.
- When the [+Y (J2)] keys are pressed, the robot will move along the Y axis plus direction. When the [-Y (J2)] keys are pressed, Move along the minus direction.
- When the [+Z (J3)] keys are pressed, the robot will move along the Z axis plus direction. When the [-Z (J3)] keys are pressed, Move along the minus direction.

◆◆◆ When the robot is in the transportation posture ◆◆◆

There are directions from which linear movement is not possible from the transportation posture. In this case, the robot will not move. Refer to section "(1) JOINT jog operation" on page 29", and move the robot to a position where linear movement is possible, and then carry out XYZ jog.

◆◆◆ If the buzzer of T/B sounds and the robot does not move ◆◆◆

If it is going to move the robot across the operation range, the buzzer of T/B sounds and the robot does not move. In this case, please move to the counter direction.

Changing the flange surface posture

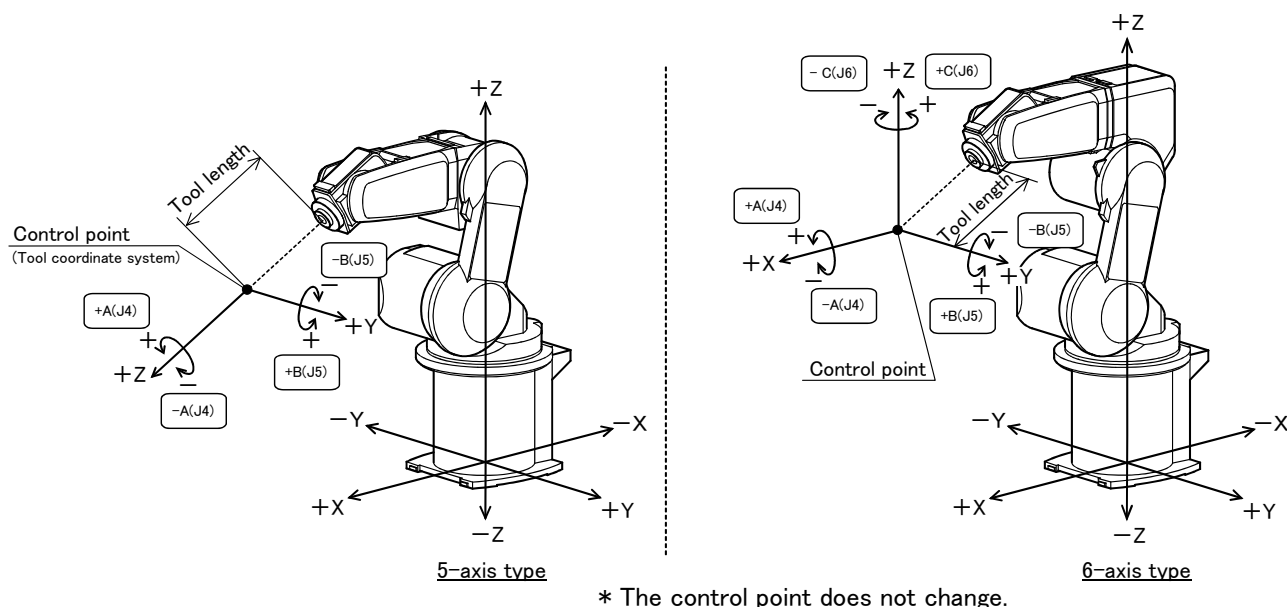

- When the [+A (J4)] keys are pressed,
 - 6-axis type: The X axis will rotate in the plus direction.
 - 5-axis type: The Z axis will rotate in the plus direction of the tool coordinate system.
- When the [-A (J4)] keys are pressed, Rotate in the minus direction.
- When the [+B (J5)] keys are pressed,
 - 6-axis type: The Y axis will rotate in the plus direction.
 - 5-axis type: The Y axis will rotate in the plus direction of the tool coordinate system.
- When the [-B (J5)] keys are pressed, Rotate in the minus direction.
- When the [+C (J6)] keys are pressed,
 - 6-axis type: The Z axis will rotate in the plus direction.
 - 5-axis type: There is no operation.
- When the [-C (J6)] keys are pressed,
 - 6-axis type: Rotate in the minus direction.
 - 5-axis type: There is no operation.

◆◆◆ When alarm No. 5150 occurs ◆◆◆

If alarm No. 5150 (ORIGIN NOT SET) occurs, the origin has not been set correctly. Reconfirm the value input for the origin data.

◆◆◆ Tool length ◆◆◆

The default tool length is 0mm, and the control point is the center of the end axis.

After installing the hand, set the correct tool length in the parameters. Refer to the separate manual "Detailed Explanation of Functions and Operations" for details.

(3) TOOL jog operation

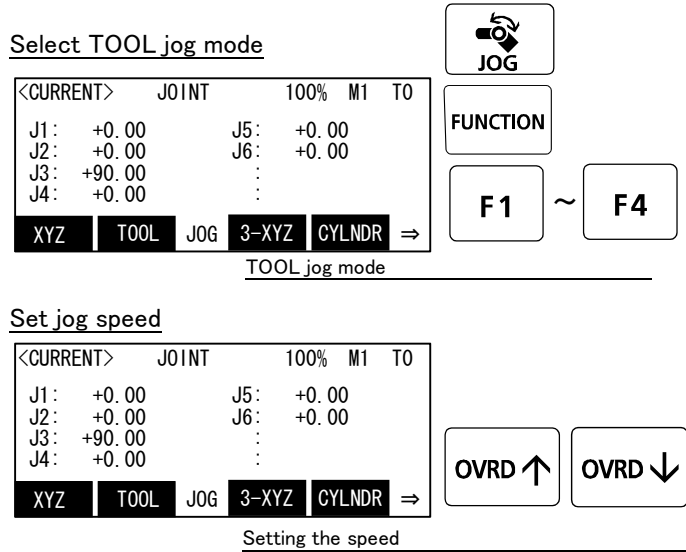

[JOG] Press the key and display the jog screen. ("JOG" is displayed on the screen bottom)
Check that the "TOOL" in jog mode is displayed on the screen.

If other jog modes are displayed, please press the function key corresponding to the "TOOL." (If the jog mode which he wishes under the screen is not displayed, it is displayed that the [FUNCTION] key is pressed)

If it finishes jog operation, press the [JOG] key again, or function key which correspond to "close."

Whenever it presses the key of [OVRD ↑], the override goes up. Conversely, if the [OVRD ↓] key is pressed, it will go down.

The current setting speed is displayed on screen upper right, and "STATUS NUMBER" of the controller.

Set the override to 10% here for confirmation work

Moving along the tool coordinate system

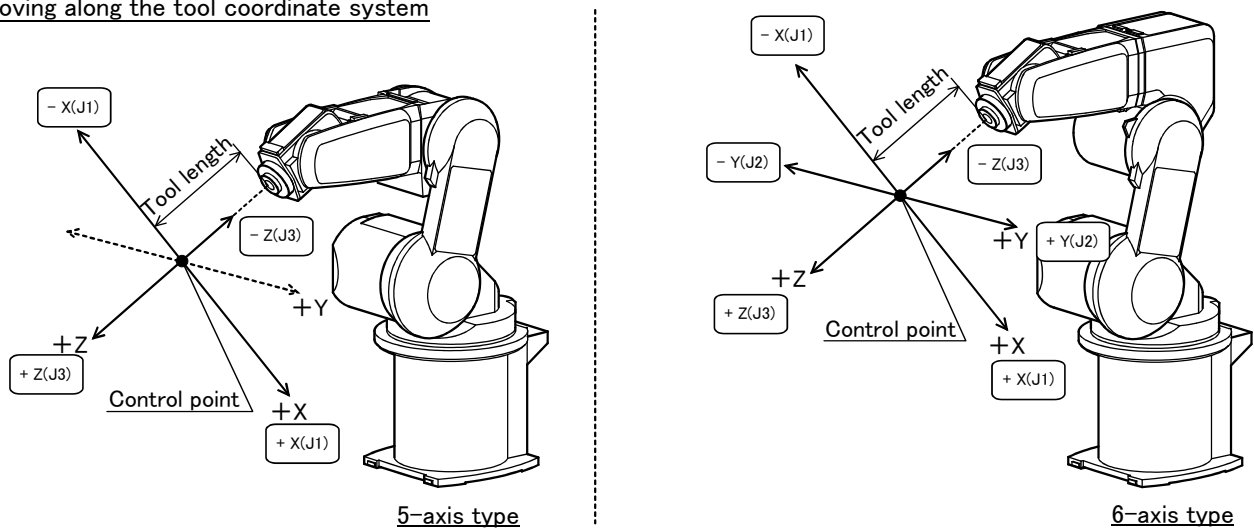

* The direction of the flange will not change

- When the [+X (J1)] keys are pressed, the robot will move along the X axis plus direction of the tool coordinate system.
- When the [-X (J1)] keys are pressed, Move along the minus direction.
- When the [+Y (J2)] keys are pressed, the robot will move along the Y axis plus direction of the tool coordinate system.
- When the [-Y (J2)] keys are pressed, Move along the minus direction. (6-axis type only)
- When the [+Z (J3)] keys are pressed, the robot will move along the Z axis plus direction of the tool coordinate system.
- When the [-Z (J3)] keys are pressed, Move along the minus direction.

◆◆◆ When the robot is in the transportation posture ◆◆◆

There are directions from which linear movement is not possible from the transportation posture. In this case, the robot will not move. Refer to section "(1) JOINT jog operation" on page 29", and move the robot to a position where linear movement is possible, and then carry out XYZ jog.

◆◆◆ If the buzzer of T/B sounds and the robot does not move ◆◆◆

If it is going to move the robot across the operation range, the buzzer of T/B sounds and the robot does not move. In this case, please move to the counter direction.

Changing the flange surface posture

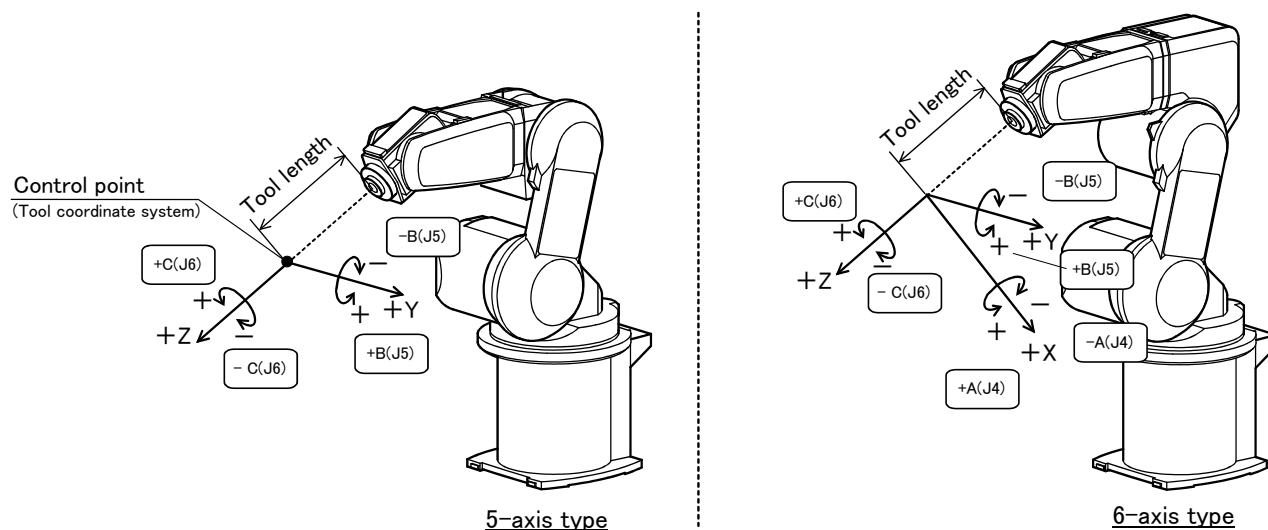

* The control point does not change.

- When the [+A (J4)] keys are pressed,
 - 6-axis type: The X axis will rotate in the plus direction of the tool coordinate system.
 - 5-axis type: There is no operation.
- When the [-A (J4)] keys are pressed,
 - 6-axis type: Rotate in the minus direction.
 - 5-axis type: There is no operation.
- When the [+B (J5)] keys are pressed,
 - 6-axis type: The Y axis will rotate in the plus direction of the tool coordinate system.
 - 5-axis type: The J5 axis will rotate in the plus direction.
- When the [-B (J5)] keys are pressed, Rotate in the minus direction.
- When the [+C (J6)] keys are pressed,
 - 6-axis type: The Z axis will rotate in the plus direction of the tool coordinate system.
 - 5-axis type: The J6 axis will rotate in the plus direction.
- When the [-C (J6)] keys are pressed, Rotate in the minus direction.

◆◆◆ When alarm No. 5150 occurs ◆◆◆

If alarm No. 5150 (ORIGIN NOT SET) occurs, the origin has not been set correctly. Reconfirm the value input for the origin data.

◆◆◆ Tool length ◆◆◆

The default tool length is 0mm, and the control point is the center of the end axis.

After installing the hand, set the correct tool length in the parameters. Refer to the separate manual "Detailed Explanation of Functions and Operations" for details.

(4) 3-axis XYZ jog operation

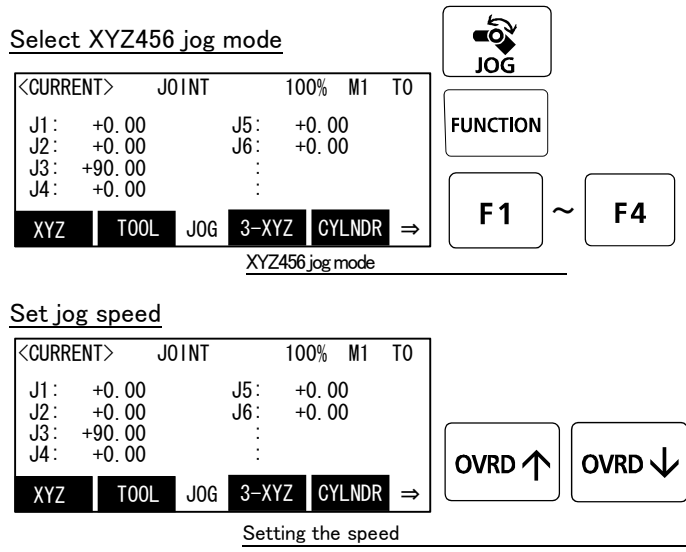

[JOG] Press the key and display the jog screen. ("JOG" is displayed on the screen bottom)

Check that the "XYZ456" in jog mode is displayed on the screen.

If other jog modes are displayed, please press the function key corresponding to the "XYZ456." (If the jog mode which he wishes under the screen is not displayed, it is displayed that the [FUNCTION] key is pressed)

If it finishes jog operation, press the [JOG] key again, or function key which correspond to "close."

Whenever it presses the key of [OVRD ↑], the override goes up. Conversely, if the [OVRD ↓] key is pressed, it will go down.

The current setting speed is displayed on screen upper right, and "STATUS NUMBER" of the controller.

Set the override to 10% here for confirmation work

Moving along the base coordinate system

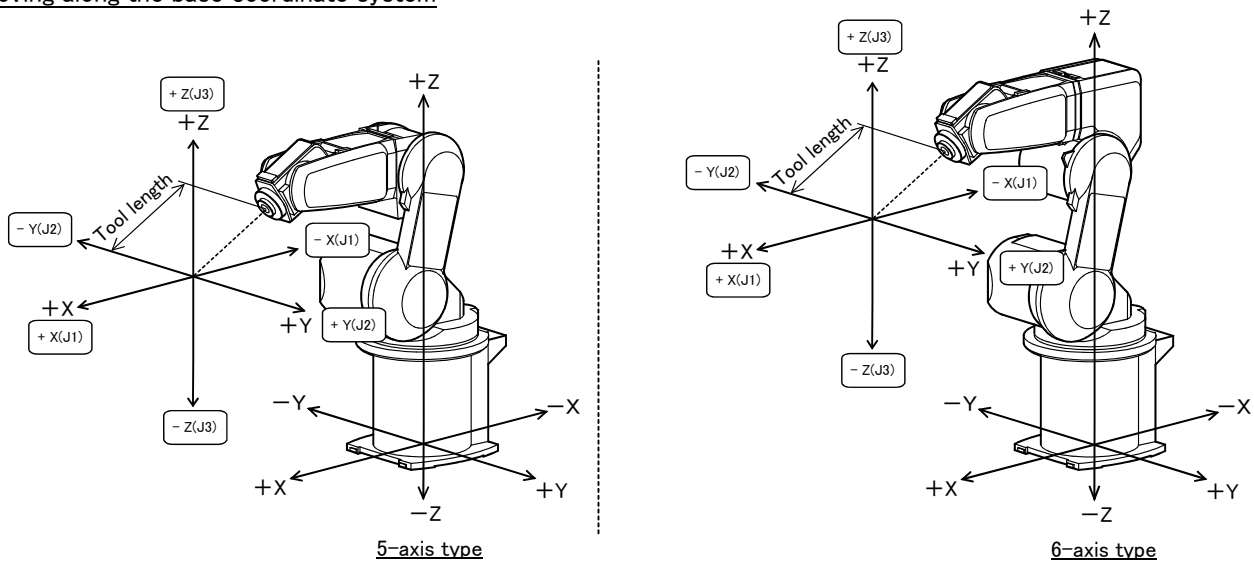

* The direction of the flange will change

- When the[+X (J1)] keys are pressed, the robot will move along the X axis plus direction. When the[-X (J1)] keys are pressed, Move along the minus direction.
- When the[+Y (J2)] keys are pressed, the robot will move along the Y axis plus direction. When the[-Y (J2)] keys are pressed, Move along the minus direction.
- When the[+Z (J3)] keys are pressed, the robot will move along the Z axis plus direction. When the[-Z (J3)] keys are pressed, Move along the minus direction.

◆◆◆ The flange surface end axis posture cannot be maintained with 3-axis XYZ jog. ◆◆◆
 With 3-axis XYZ jog, the flange surface end axis posture (orientation) is not maintained when moving linearly in the X, Y or Z axis direction.
 Use XYZ jog to maintain the posture.

Changing the flange surface posture

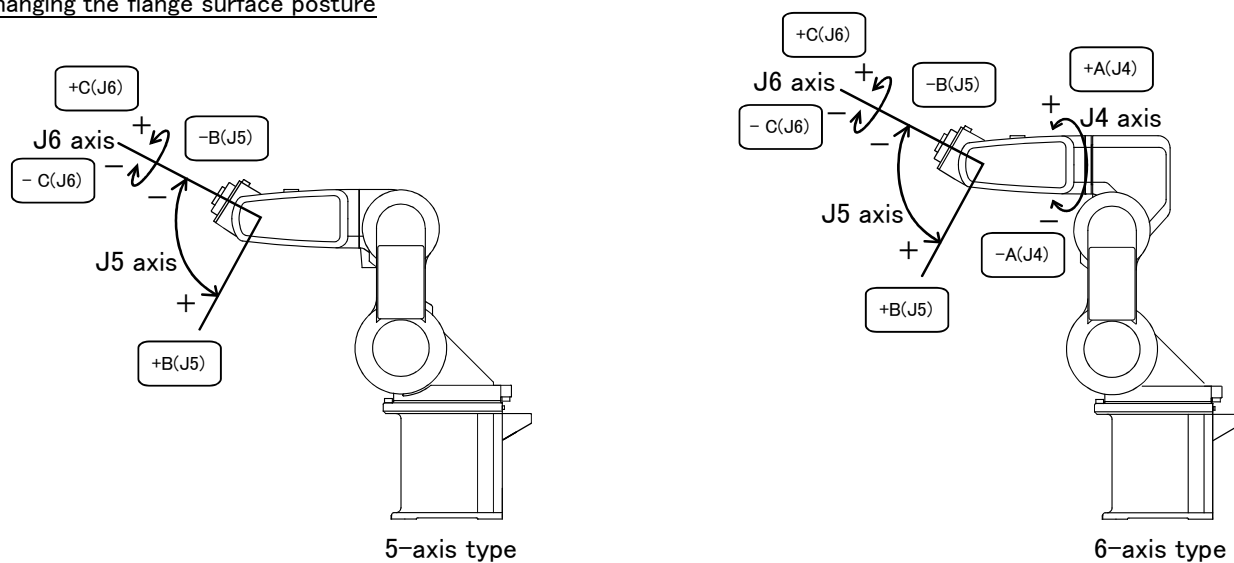

* The flange position changes.

This is the same as the J4, J5 and J6 axis JOINT jog operation.

- When the[+A (J4)] keys are pressed, the J4-axis will rotate in the plus direction.
At this time, to maintain the flange's position, other axes move simultaneously except J5 and J6.
When the[-A (J4)] keys are pressed, Rotate in the minus direction. (6-axis type only)
- When the[+B (J5)] keys are pressed, the J5-axis will rotate in the plus direction.
At this time, to maintain the flange's position, other axes move simultaneously except J4 and J6.
When the[-B (J5)] keys are pressed, Rotate in the minus direction.
- When the[+C (J6)] keys are pressed, the J6-axis will rotate in the plus direction.
When the[-C (J6)] keys are pressed, Rotate in the minus direction.

(5) CYLINDER jog operation

Select cylindrical jog mode

<CURRENT>	JOINT	100%	M1	TO
J1:	+0.00	J5:	+0.00	
J2:	+0.00	J6:	+0.00	
J3:	+90.00			
J4:	+0.00			

XYZ TOOL JOG 3-XYZ CYLNDR =>

CYLINDER jog mode

FUNCTION

F4 ~ F1

Set jog speed

<CURRENT>	JOINT	100%	M1	TO
J1:	+0.00	J5:	+0.00	
J2:	+0.00	J6:	+0.00	
J3:	+90.00			
J4:	+0.00			

XYZ TOOL JOG 3-XYZ CYLNDR =>

Setting the speed

OVRD ↑ OVRD ↓

[JOG] Press the key and display the jog screen. ("JOG" is displayed on the screen bottom)
 Check that the "CYLINDER" in jog mode is displayed on the screen.
 If other jog modes are displayed, please press the function key corresponding to the "CYLINDER." (If the jog mode which he wishes under the screen is not displayed, it is displayed that the [FUNCTION] key is pressed)
 If it finishes jog operation, press the [JOG] key again, or function key which correspond to "close."
 Whenever it presses the key of [OVRD ↑], the override goes up. Conversely, if the [OVRD ↓] key is pressed, it will go down.
 The current setting speed is displayed on screen upper right, and "STATUS NUMBER" of the controller.
 Set the override to 10% here for confirmation work

Moving along an arc centering on the Z axis

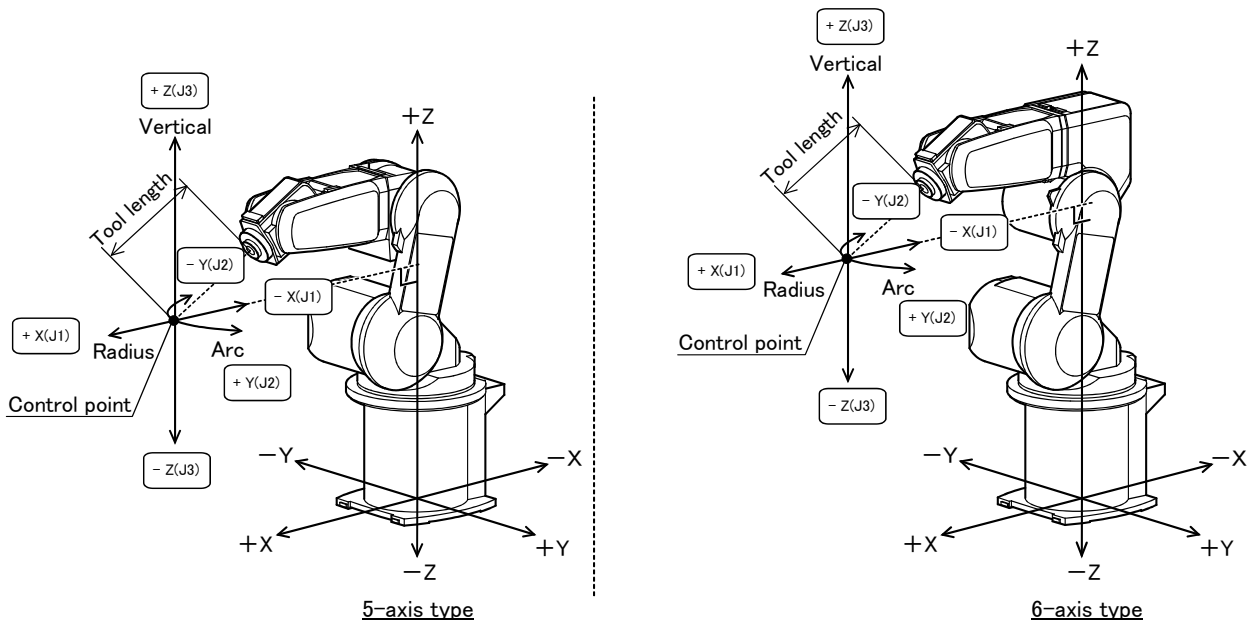

* The direction of the fringe will not change.

Assuming that the current position is on an arc centering on the Z axis, the robot moves along that arc.

- When the [+X (J1)] keys are pressed, the robot will expand in the radial direction.
 When the [-X (J1)] keys are pressed, Contract in the radial direction.
- When the [+Y (J2)] keys are pressed, the robot will move along the arc in the plus direction.
 When the [-Y (J2)] keys are pressed, Move in the minus direction.
- When the [+Z (J3)] keys are pressed, the robot will move along the Z axis plus direction.
 When the [-Z (J3)] keys are pressed, Move along the minus direction.

Changing the flange surface posture

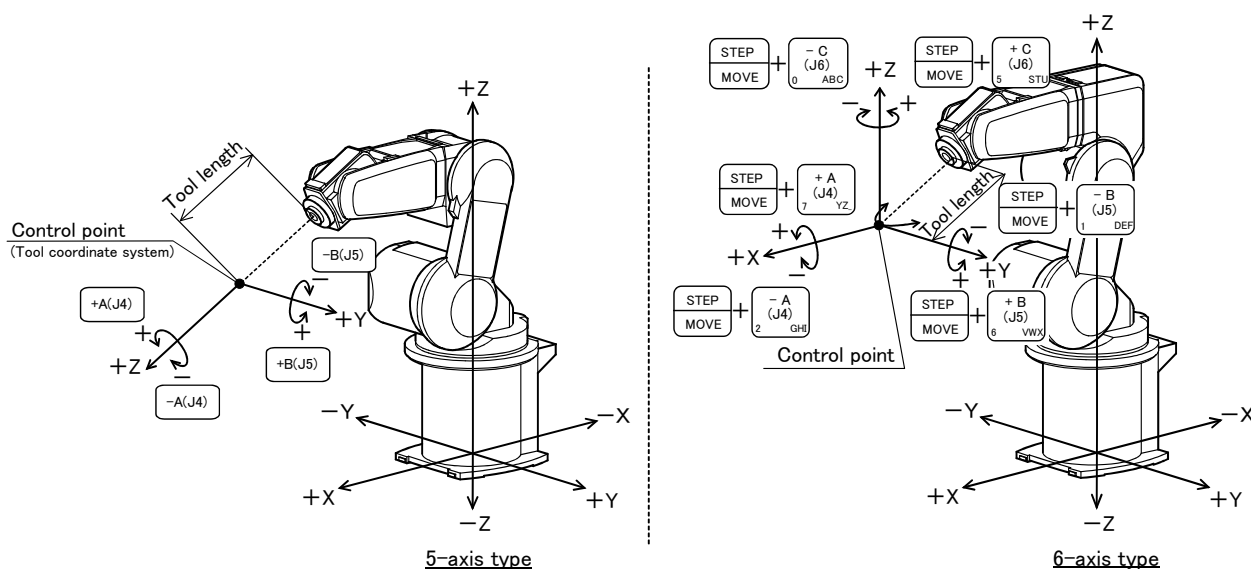

* The flange position does not change.
This is the same as the A, B and C axis XYZ jog operation.

- When the [+A (J4)] keys are pressed,
 - 6-axis type: The X axis will rotate in the plus direction.
 - 5-axis type: The Z axis will rotate in the plus direction of the tool coordinate system.
 When the [-A (J4)] keys are pressed, Rotate in the minus direction.

- When the [+B (J5)] keys are pressed,
 - 6-axis type: The Y axis will rotate in the plus direction.
 - 5-axis type: The Y axis will rotate in the plus direction of the tool coordinate system.
 When the [-B (J5)] keys are pressed, Rotate in the minus direction.

- When the [+C (J6)] keys are pressed,
 - 6-axis type: The Z axis will rotate in the plus direction.
 - 5-axis type: There is no operation.
 When the [-C (J6)] keys are pressed,
 - 6-axis type: Rotates in the minus direction.
 - 5-axis type: There is no operation.

(6) Work jog operation

Setting of the work coordinates system is necessary.

By this jog operation, robot can move along with the direction of work (or working table etc.), so teaching operations get easier.

When jog operation, select by which work coordinates the robot moves

The setting method of the work coordinates system using T/B (R32TB) is shown in the following.

(Parameter: Setting the coordinate value to WK n CORD ("n" is meaning the number (1-8) of work coordinates) can also set up the work coordinates system. Refer to the separate manual "Detailed Explanation of Functions and Operations" for details of parameter.)

In addition, this jog operation is available at the following software versions. The below-mentioned "6.ENHANCED" menu is not displayed in the other versions.

T/B :Ver.1.3 or later

SQ series: N8 or later

SD series :P8 or later

The work coordinates system teaches and sets up the three points (WO, WX, WY).

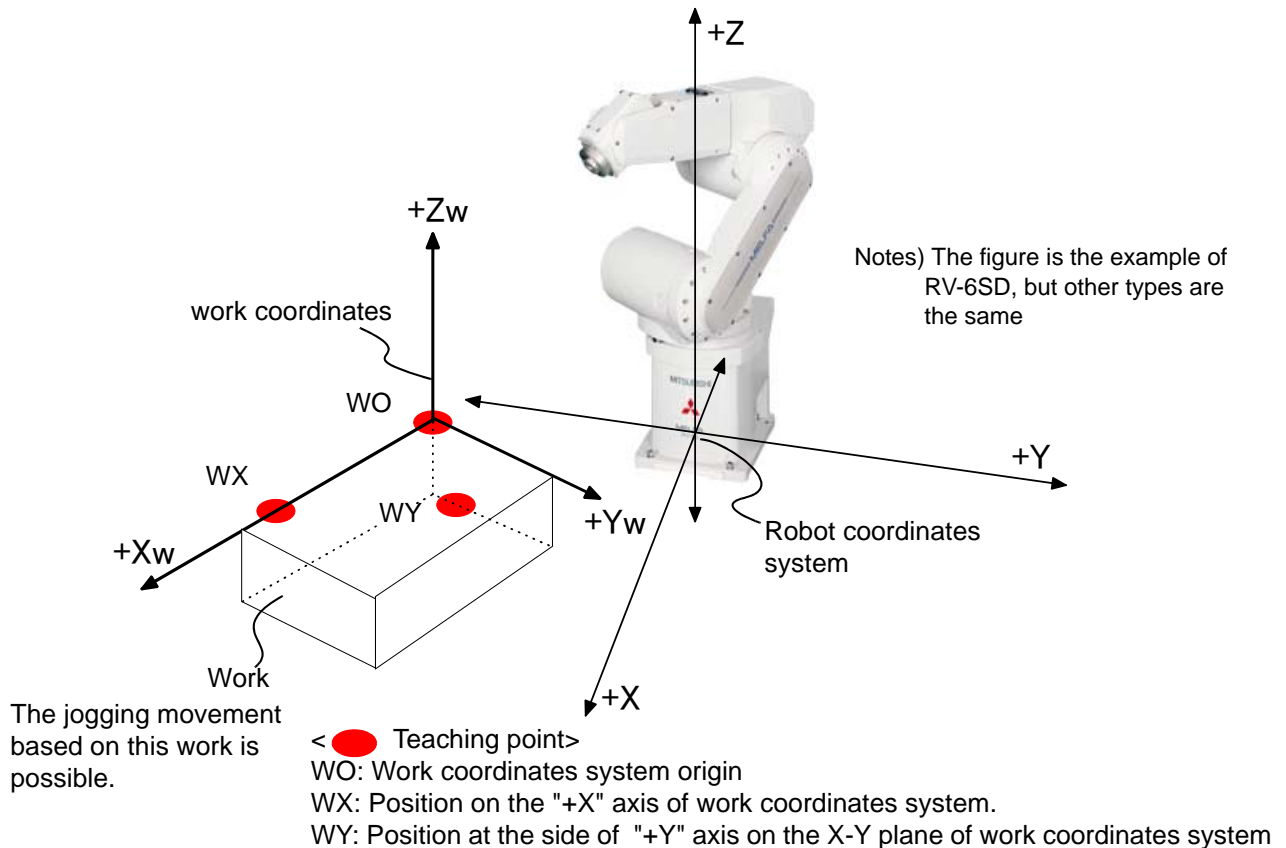

[Supplement] : The coordinate values which use all three teaching points for setting of the work coordinates system are each only X, Y, and the Z-axis. Although the coordinate value of A, B, and C axis is not used, positioning will get easy if the XYZ jog or TOOL jog movement is effected with the same value. (The direction of the hand is the same)

Fig.2-22 : Setting of the work coordinates system (teaching point)

The setting (definition) method of the work coordinates system is shown in the following.

1) Select "6.ENHANCED" screen on the <MENU> screen.

```

<MENU>
1. FILE/EDIT      2. RUN
3. PARAM.        4. ORIGIN/BRK
5. SET/INIT.     6. ENHANCED
  
```

123 CLOSE



```

<EMHANCED>
1. SQ DIRECT      2. WORK COORD.
  
```

123 CLOSE

2) Press the [2] keys in the menu screen and select "2. xxxxx."

```

<EMHANCED>
1. SQ DIRECT      2. WORK COORD.
  
```

123 CLOSE



```

<WORK COORD>      WORK NUMBER (1)
                  TEACHING POINT (WO)
X: 0.00
Y: 0.00
Z: 0.00
  
```

TEACH WX 123 WY DEFINE

The screen shows the coordinate value of the origin (WO) of the work coordinates number 1.

3) Selection of the work coordinates number

Press the [FUNCTION] keys, and display "W: JUMP" function. Press the function key corresponding to "W: JUMP"

```

<WORK COORD>      WORK NUMBER (1)
                  TEACHING POINT (WO)
X: 0.00
Y: 0.00
Z: 0.00
  
```

W. JUMP W. GRID 123 CLOSE



```

<WORK JUMP>
CHOOSE ONE OF THE WORK NUMBER
1-8.
  
```

123 CLOSE

Press numeral key [1] - [8] and specify the work coordinates number. The coordinate value of the specified work coordinates system is displayed.

```

<WORK JUMP>
CHOOSE ONE OF THE WORK NUMBER
1-8.
  
```

123 CLOSE



```

<WORK COORD>      WORK NUMBER (2)
                  TEACHING POINT (WO)
X: 0.00
Y: 0.00
Z: 0.00
  
```

W. JUMP W. GRID 123 CLOSE

The screen is the example which specified the work coordinates number 2. ("2" at the upper right of the screen)

Operation will be canceled if the [CLOSE] key is pressed.

4) The teaching of the work coordinates system

Teach the three points shown in Fig. 2-22. Confirm the name currently displayed on the "TEACHING POINT" at the upper right of the screen. If it differs, press the function key corresponding to each point(WO, WX, WY) to teach. Move the robot's arm by jog operation (other jogging movement), and press the function key corresponding to "TEACH."([F1]) The confirmation screen is displayed.

```

<WORK COORD>      WORK NUMBER (2)
                  TEACHING POINT (WO)
X: 0.00
Y: 0.00
Z: 0.00
  
```

TEACH WX 123 WY DEFINE



```

<WORK COORD>      WORK NUMBER (2)
TEACHING POINT (WO)
RECORD CURRENT POSITION.
OK?
  
```

Yes 123 No

Specify the teaching point [WO],[WX],[WY]
teaching the position [TEACH]

Presses the function key corresponding to "Yes", the robot's current position is registered, and the registered coordinates value is display. Operation will be canceled if the [CLOSE] key is pressed.

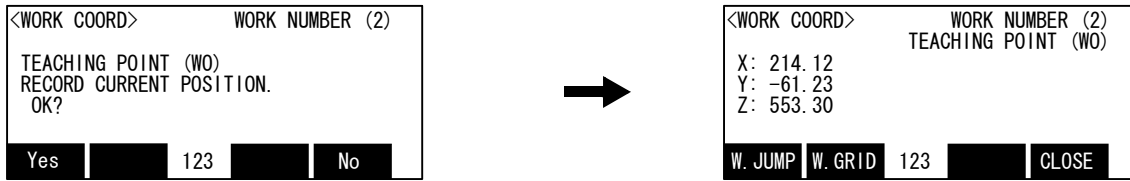

Teach the three points, WO, WX, and WY, by the same operation. The position data taught here is each registered into the following parameters. ("n" means the work coordinates numbers 1-8)

- WO= parameter: WKnWO
- WX= parameter: WKnWX
- WY= parameter: WKnWY

5) Setting of work coordinates (definition)

If the function key corresponding to "DEFINE" ([F1]) is pressed, the work coordinates system will be calculated using the three points, and the result will be displayed.

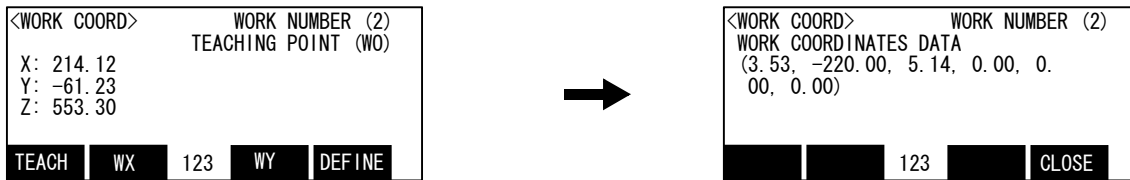

The alarm occurs if the work coordinates system is incalculable. (There are the three points on the straight line, or the two points have overlapped) In this case, reset alarm and re-teach the three points.

This work coordinate data is registered into parameter: WKnCORD. ("n" means the work coordinates numbers 1-8)

If the function key corresponding to "CLOSE" is pressed, it will return to the previous screen.

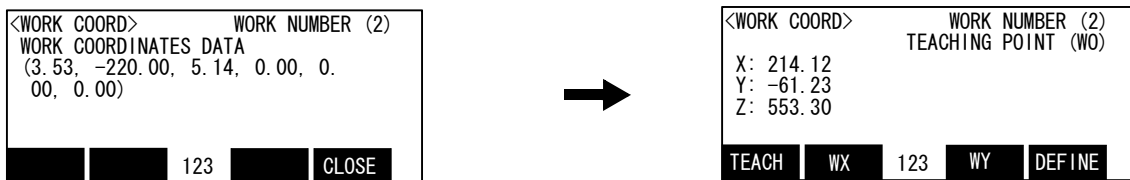

6) Finishing of setting the work coordinates

Press the [FUNCTION] keys, and display "CLOSE" function. Press the function key corresponding to "CLOSE". Returns to the <MENU> screen.

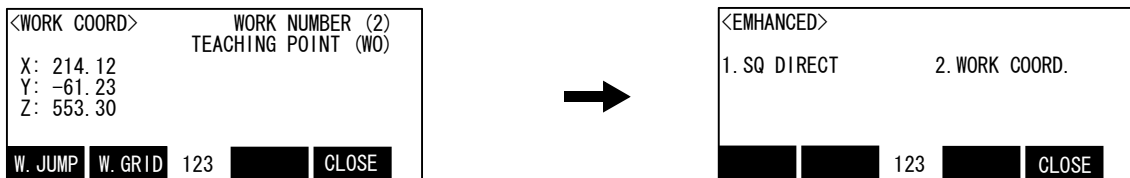

Although setting of work coordinates is finishing above, confirmation of work coordinates can be done by pressing the function key corresponding to "W GRID."([F2])

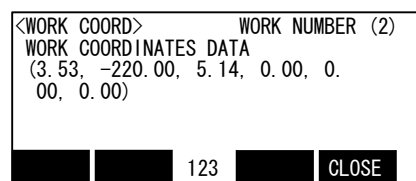
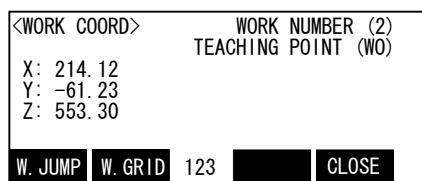

Return to the previous screen by pressing the [CLOSE] ([F4]) key.

Then, the operation method of the work jog is shown. Change to the work jog after nearing the work.

Select WORK jog mode

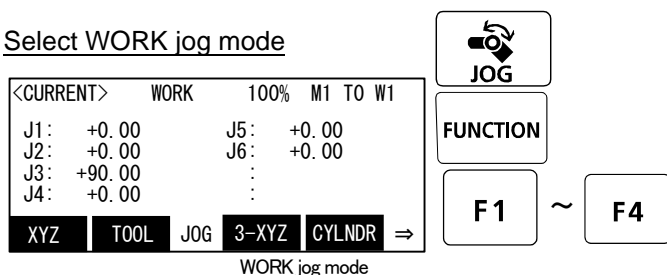

[JOG] Press the key and display the jog screen. ("JOG" is displayed on the screen bottom)

Check that the "WORK" in jog mode is displayed on the screen.

If other jog modes are displayed, please press the function key corresponding to the "WORK." (If the jog mode which he wishes under the screen is not displayed, it is displayed that the [FUNCTION] key is pressed)

If it finishes jog operation, press the [JOG] key again, or function key which correspond to "close."

Confirmation and selection of the work coordinates system

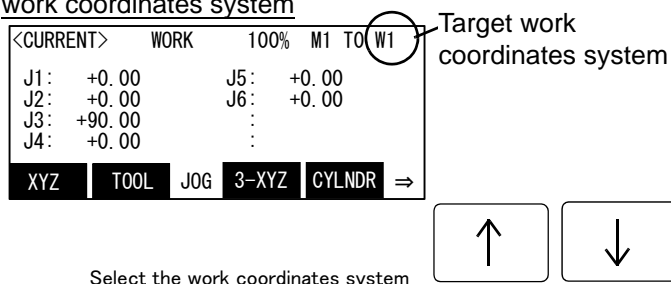

Confirm the target work coordinates system. The current target number is displayed on the screen upper right. (W1~W8)

The number of work coordinates can be changed by the arrow key [Upper arrow], [Lower arrow]

Push the key [Upper arrow], the number will increase. (W1, W2, W8) Conversely, push the key [Lower arrow], the number will decrease

CAUTION

Always confirm that the number of the target work coordinates system is displayed correctly (Display of W1~W8 at the upper right of the screen)

If mistaken, the robot will move in the direction which is not meant and will cause the damage and the personal injuries.

Set jog speed

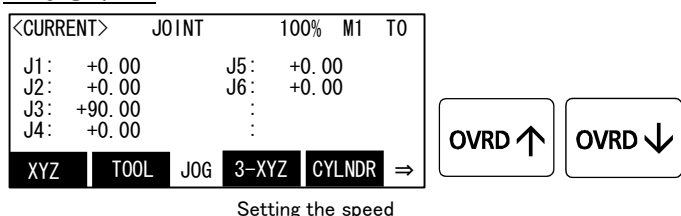

Whenever it presses the key of [OVRD(Upper arrow)], the override goes up. Conversely, if the [OVRD(Lower arrow)] key is pressed, it will go down.

The current setting speed is displayed on screen upper right, and "STATUS NUMBER" of the controller.

Set the override to 10% here for confirmation work

The jog movement based on work coordinates system

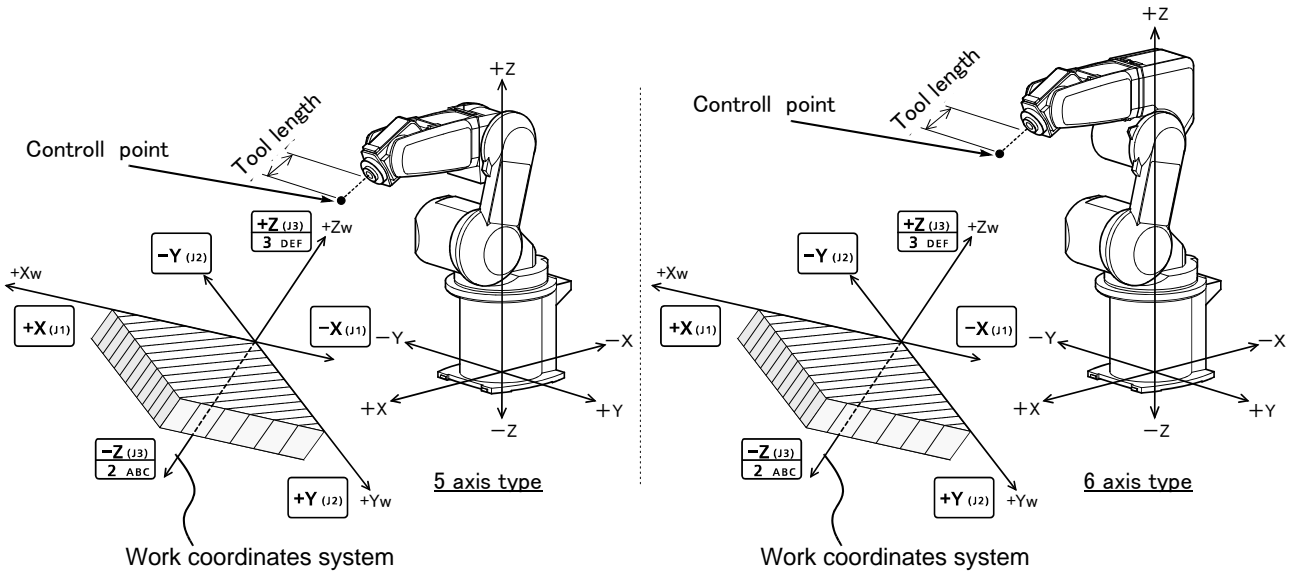

* The direction of the flange will not change. Move the control point with a straight line in accordance with the work coordinates system

- When the[+X (J1)] keys are pressed, the robot will move along the X axis plus direction on the work coordinates system.
When the[-X (J1)] keys are pressed, Move along the minus direction.
- When the[+Y (J2)] keys are pressed, the robot will move along the Y axis plus direction on the work coordinates system.
When the[-Y (J2)] keys are pressed, Move along the minus direction.
- When the[+Z (J3)] keys are pressed, the robot will move along the Z axis plus direction on the work coordinates system.
When the[-Z (J3)] keys are pressed, Move along the minus direction.

Changing the flange surface posture

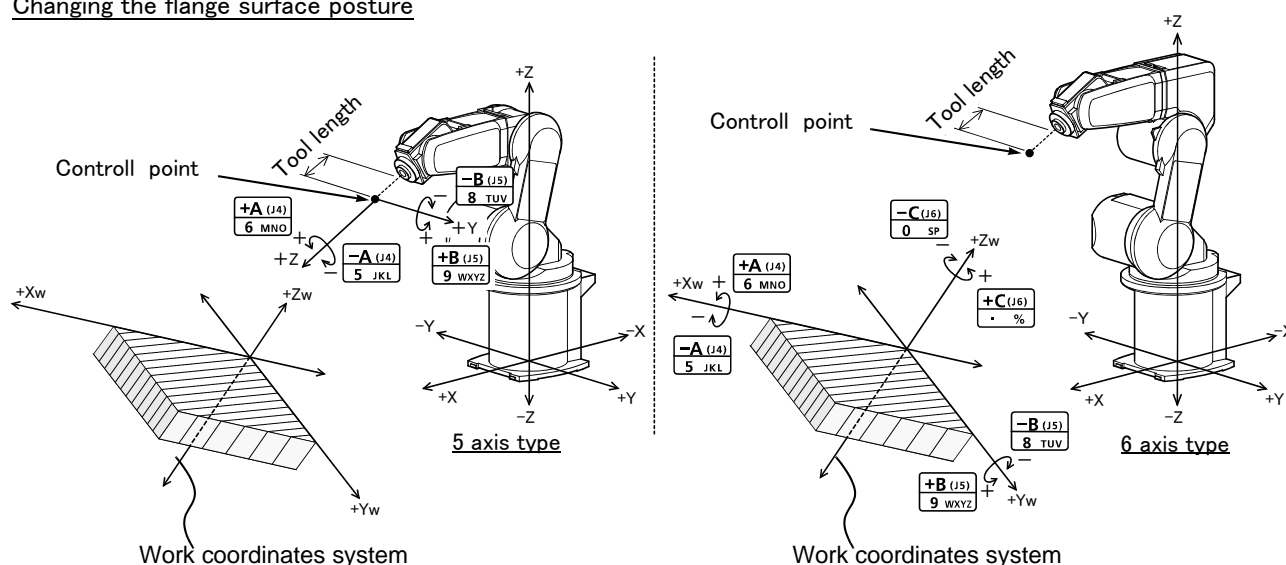

* The position of the control point does not change.
Change the direction of the flange in accordance with the work coordinates system. (6 axis type)

- When the [+A (J4)] keys are pressed,
 - 6-axis type: The X axis will rotate in the plus direction of the work coordinate system.
 - 5-axis type: There is no operation.
- When the [-A (J4)] keys are pressed,
 - 6-axis type: Rotate in the minus direction.
 - 5-axis type: There is no operation.
- When the [+B (J5)] keys are pressed,
 - 6-axis type: The Y axis will rotate in the plus direction of the work coordinate system..
 - 5-axis type: The Y axis will rotate in the plus direction of the tool coordinate system.
- When the [-B (J5)] keys are pressed, Rotate in the minus direction.
- When the [+C (J6)] keys are pressed,
 - 6-axis type: The Z axis will rotate in the plus direction of the work coordinate system...
 - 5-axis type: There is no operation.
- When the [-C (J6)] keys are pressed,
 - 6-axis type: Rotate in the minus direction.
 - 5-axis type: There is no operation.

◆◆◆ When the robot is in the transportation posture ◆◆◆

There are directions from which linear movement is not possible from the transportation posture. In this case, the robot will not move. Refer to section "(1) JOINT jog operation" on page 29", and move the robot to a position where linear movement is possible, and then carry out XYZ jog.

◆◆◆ If the buzzer of T/B sounds and the robot does not move ◆◆◆

If it is going to move the robot across the operation range, the buzzer of T/B sounds and the robot does not move. In this case, please move to the counter direction.

◆◆◆ Tool length ◆◆◆

The default tool length is 0mm, and the control point is the center of the end axis.

After installing the hand, set the correct tool length in the parameters. Refer to the separate manual "Detailed Explanation of Functions and Operations" for details.

3 Installing the option devices

The installation of the solenoid valve set, the hand input cable, the hand output cable and retrieval of the spare wiring require removal of the same cover. Therefore, it is better to install them simultaneously.

3.1 Installing the solenoid valve set (1S-VD0*(E)-02)

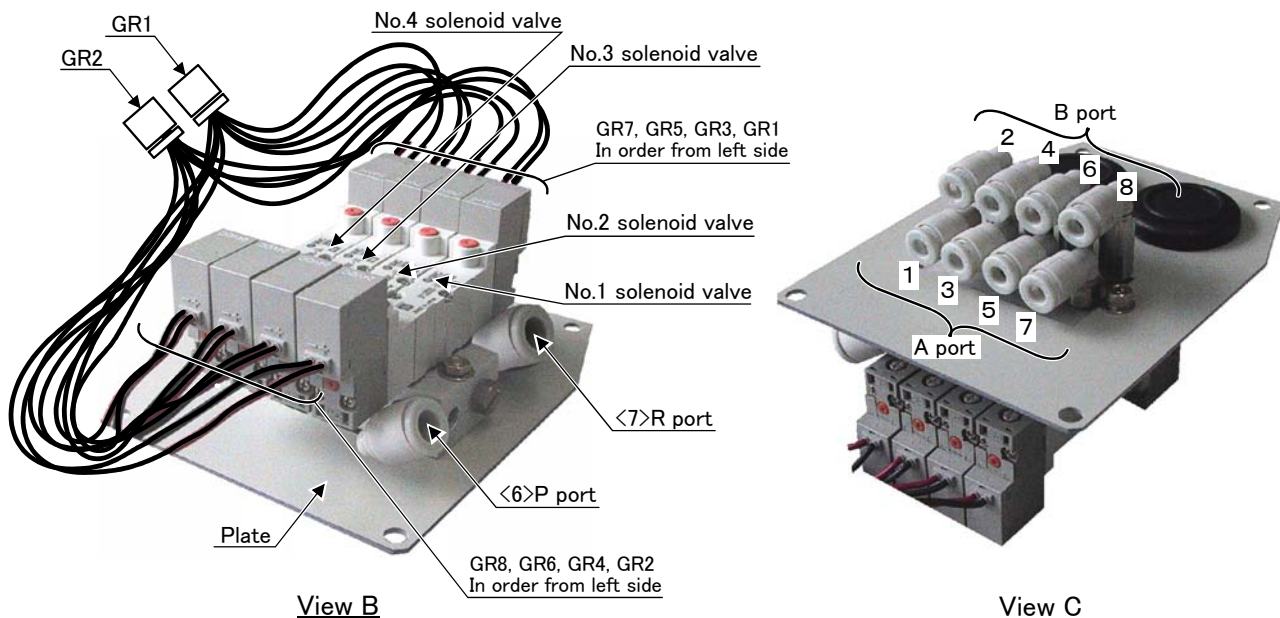
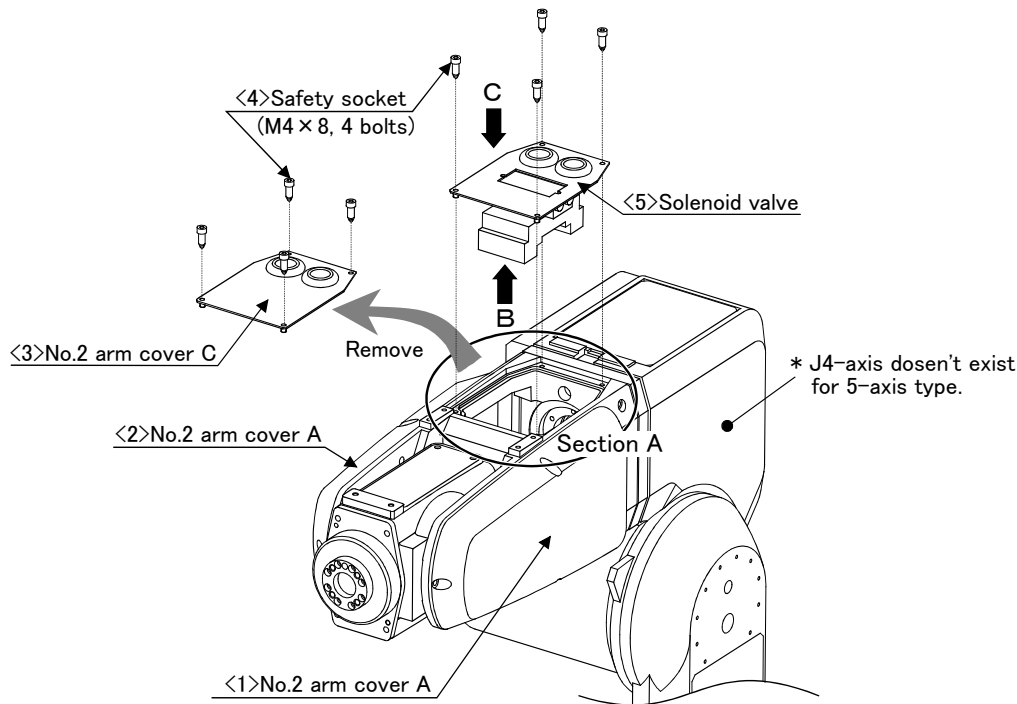

Fig.3-1 : Solenoid valve installation procedures

Fig. 3-1 and Fig. 3-2 shows the solenoid valve installation procedures and the solenoid valve connector connection procedures. The installation procedures are as follow. This work must be carried out with the controller power turned OFF.

- 1) Refer to "5.3.2Installing/removing the cover" on page 52 and remove the No. 2 arm cover A <2>, and the No. 2 arm cover C <3>.

- 2) If you are not using the spare line (ADD: stored in a coil) in section A shown in Fig. 3-1, remove it. The spare line is connected to a connector inside section A.
- 3) Connect the connectors of "GR1" and "GR2" stored in section A to the connectors of "GR1" and "GR2" coming out of the solenoid valves. Store the connectors near the location marked with ○ shown in Fig. 3-2.

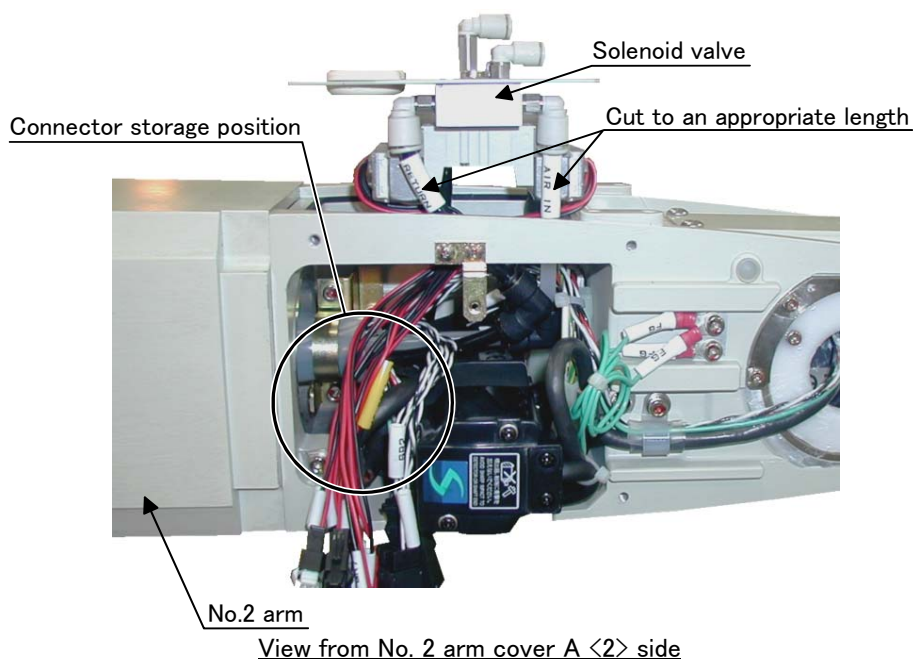

Fig.3-2 : Solenoid valve installation diagram details 1

- 4) The length of the two air hoses ($\phi 6$) stored in section A is longer than necessary by assuming the use of a solenoid valve set not manufactured by Mitsubishi. Cut off the air hoses to an appropriate length, and connect them to the couplings.
- 5) Of the two air hoses ($\phi 6$), the one marked with "AIR IN" is for connecting the quick coupling (P port) <6> of the solenoid valves, and the other marked with "RETURN" is for connecting the quick coupling (R port) <7> of the solenoid valves. If you use the joint of "RETURN" on the base of robot, remove the cap for protection against dust. If it is attached, exhaust pressure increases and the solenoid valve may not operate normally. And, the hose can be connected to this joint and the exhaust can be drawn.
- 6) Using the screw holes of the No. 2 arm cover C <3>, mount the solenoid valves with the safety socket (four M4 x 8) attached to the solenoid valves. When mounting the solenoid valves, be careful not to damage the sponge sealing material attached to the opening of section A. If the sealing material is damaged, it may degrade the protection specification.

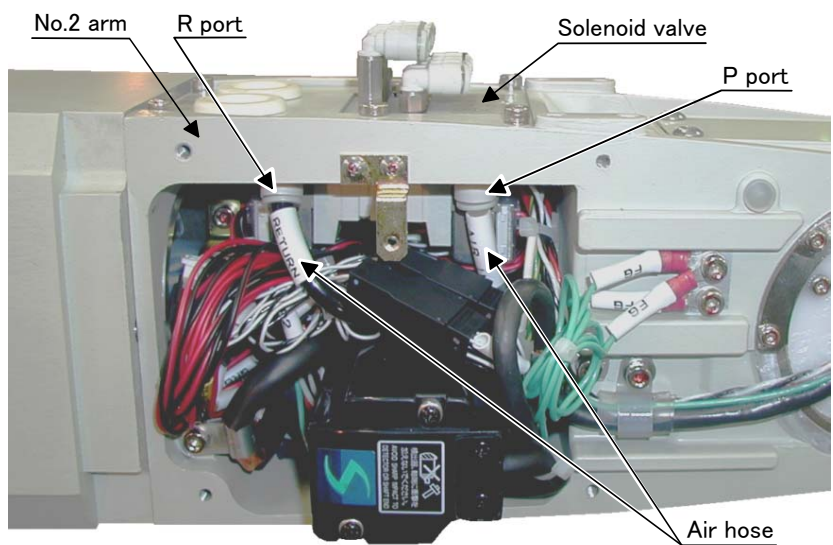

Fig.3-3 : Solenoid valve installation diagram details 2

7) When you have completed the installation, reinstall the No.2 arm cover A <2> to its original position, and be careful not to entangle the cables when you do so.

The connections after the installation appear as in Table 3-1 for single type valves, hand 2 is not applicable.

Table 3-1 : Solenoid valve ports and hoses: Correspondence of couplings and hand ports

Hand	Hand port	Solenoid valve port	Solenoid valve used
Hand 1	OPEN	1	First set
	CLOSE	2	
Hand 2	OPEN	3	Second set
	CLOSE	4	
Hand 3	OPEN	5	Third set
	CLOSE	6	
Hand 4	OPEN	7	Fourth set
	CLOSE	8	

3.2 Installing the hand input cable

The procedure for installing the hand input cable is as follows. Conduct work by referring to "Fig. 3-1 Solenoid valve installation procedures" on page 45 and "Fig. 3-4 Installing the hand input cable" on page 48 below.

This work must be carried out with the controller power turned OFF.

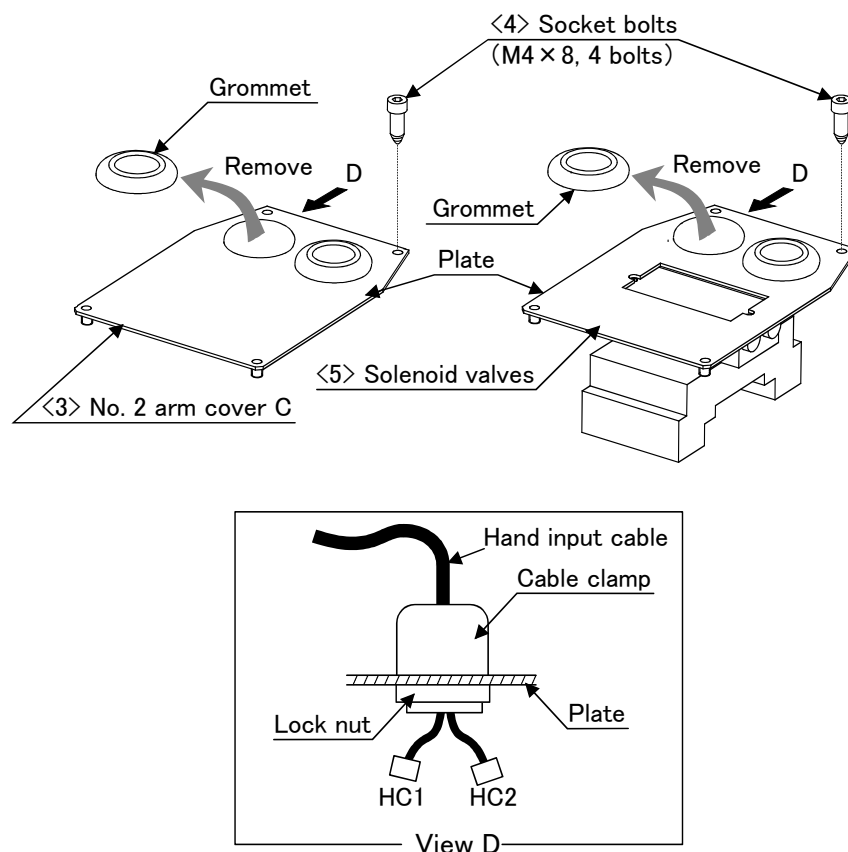

Fig.3-4 : Installing the hand input cable

- 1) Refer to "5.3.2 Installing/removing the cover" on page 52 and remove the No. 2 arm cover A <2>, and the No. 2 arm cover C <3> or the solenoid valves <5>.
- 2) If you are not using the spare line (ADD: stored in a coil) in section A shown in Fig. 3-1, remove it. The spare line is connected to a connector inside section A.
- 3) The hand input cable can be fixed to either the No. 2 arm cover C <3> or the solenoid valves <5>.
- 4) Remove one of the two grommets on either the No. 2 arm cover C <3> or the solenoid valves <5>. After removing the grommet, peel off the sealing material left on the hole section of the plate.
- 5) After removing the lock nut attached to the hand input cable, feed the connector side of the hand input cable (with a cable clamp) through the hole on the plate. Replace the removed lock nut in position and fasten it securely.
- 6) Connect the connectors of "HC1" and "HC2" stored in section A shown in Fig. 3-1 to "HC1" and "HC2" of the hand input cable.
- 7) Mount the No. 2 arm cover C <3> or the solenoid valves <5> to section A shown in Fig. 3-1. When mounting, be careful not to damage the sponge sealing material attached to the opening of section A. If it is damaged, the protection performance may be lowered.
- 8) When you have completed the installation, reinstall the No.2 arm cover B <2> to its original position, and be careful not to entangle the cables when you do so.

3.3 Installing the hand output cable

The procedure for installing the hand output cable is as follows.

This work must be carried out with the controller power turned OFF.

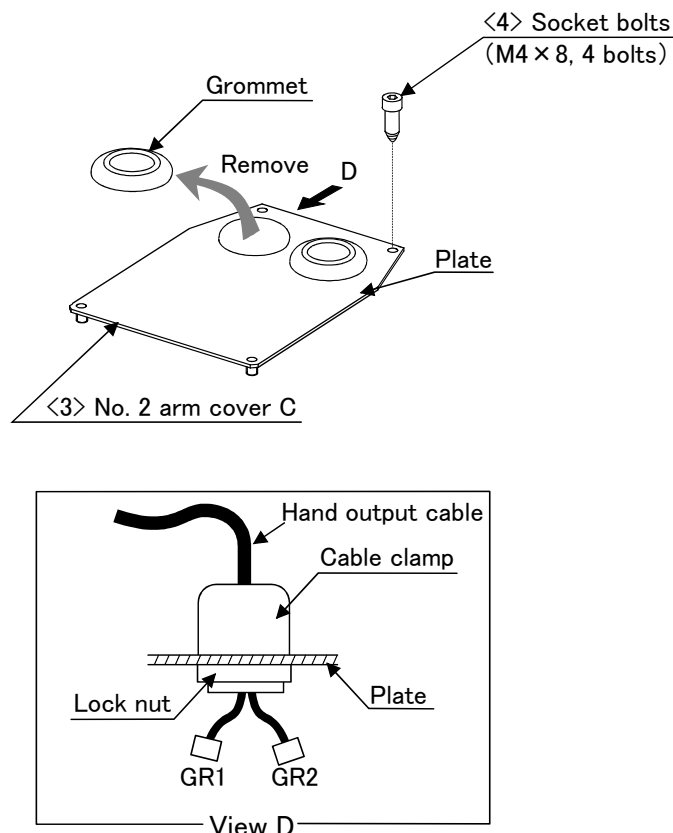

Fig.3-5 : Installing the hand output cable

- 1) Refer to "5.3.2Installing/removing the cover" on page 52 and remove the No. 2 arm cover A <2>, and the No. 2 arm cover C <3>.
- 2) If you are not using the spare line (ADD: stored in a coil) in section A shown in Fig. 3-1, remove it. The spare line is connected to a connector inside section A.
- 3) The hand output cable will be fixed to the No. 2 arm cover C <3>. (attached to the solenoid valve set)
- 4) Remove one of the two grommets on either the No. 2 arm cover C <3>. After removing the grommet, peel off the sealing material left on the hole section of the plate.
- 5) After removing the lock nut attached to the hand output cable, feed the connector side of the hand output cable (with a cable clamp) through the hole on the plate. Replace the removed lock nut in position and fasten it securely.
- 6) Connect the connectors of "GR1" and "GR2" stored in section A shown in Fig. 3-1 to "GR1" and "GR2" of the hand output cable.
- 7) Mount the No. 2 arm cover C <3> to section A shown in Fig. 3-1. When mounting, be careful not to damage the sponge sealing material attached to the opening of section A. If it is damaged, the protection performance may be lowered.
- 8) When you have completed the installation, reinstall the No.2 arm cover B <2> to its original position, and be careful not to entangle the cables when you do so.

3.4 Changing the operating range

3.4.1 J1 axis

The operating range of the J1 axis can be changed to the range shown in [Table 3-2](#). (Option)

Table 3-2 : Operating range alternative range

Axis		Standard	Alternative angle					
J 1	+side	Angle	+170	+120	+90	+60	+30	One of the points shown on the left
		Insertion position	None	A	B	C	D	
	-side	Angle	-170	-120	-90	-60	-30	One of the points shown on the left
		Insertion position	None	a	b	c	d	

Note) The insertion position given in the table indicates the insertion position for the operating range change stopper. (Refer to [Fig. 3-6](#).)

The operating range is changed with robot arm settings and parameter settings.

(1) Setting the robot arm

- 1) Move the upper arm to the posture as shown in [Fig. 3-6](#) by jog operation.
- 2) Turn OFF the controller power.
- 3) By referring to [Table 3-2](#) and [Fig. 3-6](#), insert the two stoppers (M10 x 20) used to change the movement range of J1 axis at the angular position to be changed, and fix securely by applying a clamping torque of 70 to 86 N · m.



CAUTION Do not remove the stopper for the standard specification of ± 170 degree shown in [Fig. 3-6](#).

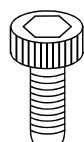

Type: 1S-DH-03
Specification:
Hexagon socket bolt (2 bolts)
M10 x 20 plating
Strength classification 10.9

Detail of the stopper used to change the operating range of the J1 axis

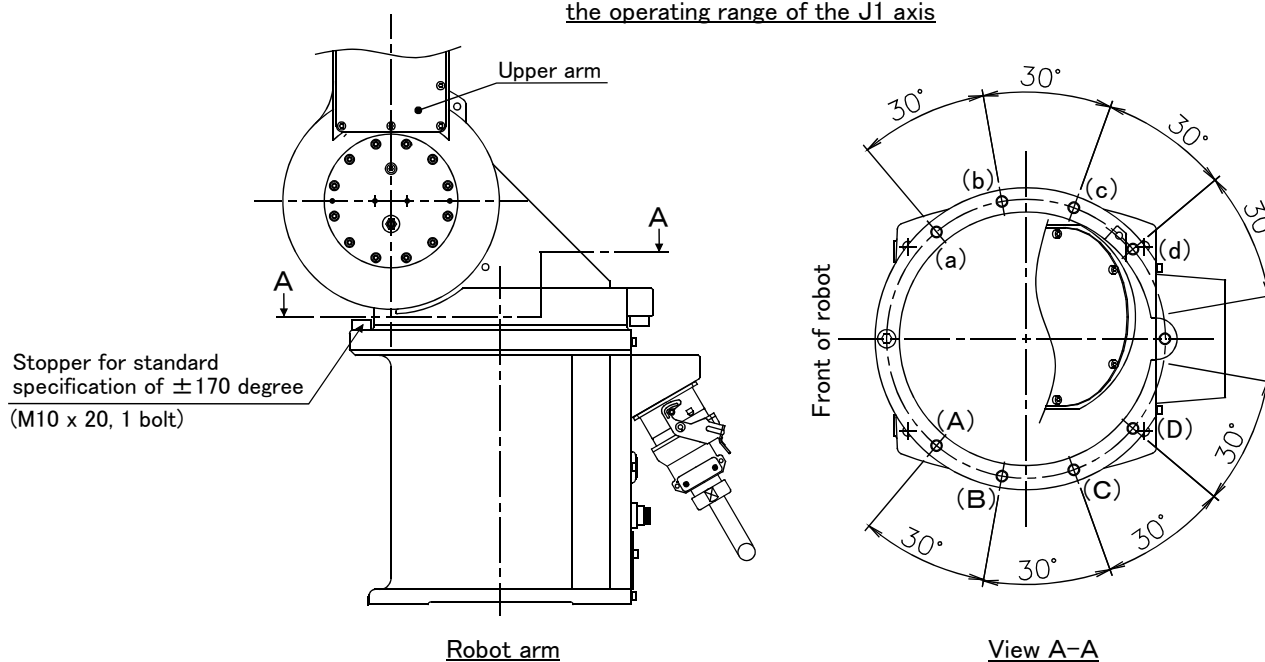

Fig.3-6 : Installation of operating range change option

(2) Setting the parameters

- 1) Change the values of the first element (J1 axis minus side) and second element (J1 axis plus side) of the joint operating range parameter MEJAR. Set the value to the angle corresponding to the position where the operating range change stopper was inserted in [“\(1\)Setting the robot arm”](#) above. Refer to the separate “Instruction Manual/Detailed Explanation of Functions and Operations” for details on changing the parameter.
- 2) To change the operating range on the plus side, the mechanical stopper origin parameter MORG must be changed in addition to the above parameter. Set the first element value of parameter MORG to the value indicated in [Table 3-3](#). Refer to the separate “Instruction Manual/Detailed Explanation of Functions and Operations” for details on the operations.

Table 3-3 : Change value of parameter MORG

Plus side change angle	Change value for MORG 1st element
120°	122.4
90°	92.4
60°	62.4
30°	32.4

- 3) When completed changing the parameters, turn the controller power OFF and ON. Move the waist axis to the operating range limit with JOINT jog operation, and confirm that the limit over occurs and the robot stops at the angle changed for both the +/- sides.

This completes setting the parameters and the changing of the operating range.

4 Basic operations

The basic operations from creating the program to automatic operation are explained in section "4. Basic operations" in the "From Controller Setup to Maintenance" manual. Refer that manual as necessary.

5 Maintenance and Inspection

The maintenance and inspection procedures to be carried out to use the robot for a long time without trouble are described in this chapter. The types and replacement methods of consumable parts are also explained.

5.1 Maintenance and inspection interval

Maintenance and inspection are divided into the inspections carried out daily, and the periodic inspections carry out at set intervals. Always carry these out to prevent unforeseen trouble, to maintain the product for a long time, and to secure safety.

(1) Inspection schedule

In addition to the monthly inspection, add the following inspection items every three months (estimated at 500 Hr operation hours).

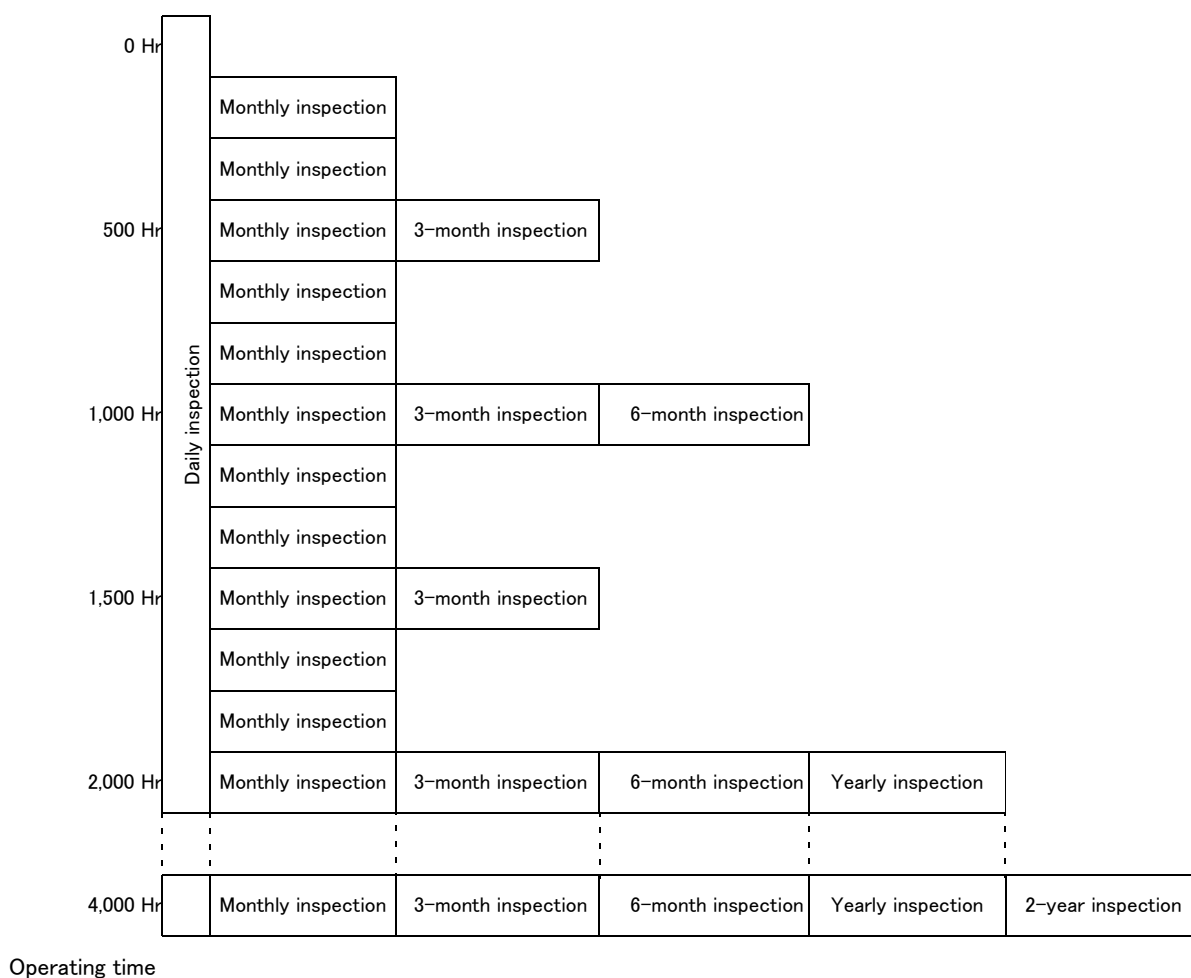

<Guideline for inspection period>

For one shift

$$8 \text{ Hr/day} \times 20 \text{ days/month} \times 3 \text{ months} = \text{approx. } 500 \text{ Hr}$$

$$10 \text{ Hr/day} \times 20 \text{ days/month} \times 3 \text{ months} = \text{approx. } 600 \text{ Hr}$$

For two shifts

$$15 \text{ Hr/day} \times 20 \text{ days/month} \times 3 \text{ months} = \text{approx. } 1000 \text{ Hr}$$

[Caution] When using two lines, the 3-month inspection, 6-month inspection and yearly inspection must be carried out when half the time has passed.

Fig.5-1 : Inspection schedule

5.2 Inspection items

The inspection items for the robot arm are shown below.

Also refer to section "5. Maintenance and inspection" in the "Controller setup, basic operation, and maintenance" manual, and inspect the controller.

5.2.1 Daily inspection items

Carry out the daily inspections with the procedures given in [Table 5-1](#).

Table 5-1 : Daily inspection items (details)

Procedure	Inspection item (details)	Remedies
Before turning power ON (Check the following items before turning the power ON.)		
1	Are any of the robot installation bolts loose? (Visual)	Securely tighten the bolts.
2	Are any of the cover tightening screws loose? (Visual)	Securely tighten the screws.
3	Are any of the hand installation bolts loose? (Visual)	Securely tighten the bolts
4	Is the power supply cable securely connected? (Visual)	Securely connect.
5	Is the machine cable between the robot and controller securely connected? (Visual)	Securely connect.
6	Are there any cracks, foreign contamination or obstacles on the robot and controller cover?	Replace with a new part, or take remedial measures.
7	Is any grease leaking from the robot arm? (Visual)	After cleaning, replenish the grease.
8	Is there any abnormality in the pneumatic system? Are there any air leaks, drain clogging or hose damage? Is the air source normal? (Visual)	Drain the drainage, and remedy the air leaks (replace the part).
After turning the power ON (Turn the power ON while monitoring the robot.)		
1	Is there any abnormal motion or abnormal noise when the power is turned ON?	Follow the troubleshooting section.
During operation (try running with an original program)		
1	Check whether the movement points are deviated? Check the following points if there is any deviation. 1. Are any installation bolts loose? 2. Are any hand installation section bolts loose? 3. Are the positions of the jigs other than the robot deviated? 4. If the positional deviation cannot be corrected, refer to "Troubleshooting", check and remedy.	Follow the troubleshooting section.
2	Is there any abnormal motion or abnormal noise? (Visual)	Follow the troubleshooting section.

5.2.2 Periodic inspection

Carry out periodic inspection with the procedures given in [Table 5-2](#).

Table 5-2 : Periodic inspection items (details)

Procedure	Inspection item (details)	Remedies
Monthly inspection items		
1	Are any of the bolts or screws on the robot arm loose?	Securely tighten the bolts.
2	Are any of the connector fixing screws or terminal block terminal screws loose?	Securely tighten the screws.
3	Remove the cover at each section, and check the cables for wear damage and adherence of foreign matter.	Check and eliminate the cause. If the cables are severely damaged, contact the Mitsubishi Service Department.
3-month inspection items		
1	Is the timing belt tension abnormal?	If the timing belt is loose or too tense, adjust it.
6-month inspection items		
1	Is the friction at the timing belt teeth severe?	If the teeth are missing or severe friction is found, replace the timing belt.
Yearly inspection items		
1	Replace the backup battery in the robot arm.	Exchange it referring to "5.3.5 Replacing the backup battery" on page 66.
3-year inspection items		
1	Lubricate the grease at the harmonic reduction gears for each axis	Lubricate it referring to "5.3.4 Lubrication" on page 64

5.3 Maintenance and inspection procedures

The procedures for carrying out the periodic maintenance and inspection are described in this section. Thoroughly read the contents, and follow the instructions. This work can be commissioned to the Mitsubishi Service Department for a fee. (Never disassemble, etc., the parts not described in this manual.)

The maintenance parts, etc., required for the customer to carry out maintenance and inspection are described in "5.4 Maintenance parts" on page 68 of this manual. Always contact your dealer when parts are needed.



CAUTION

The origin of the machine system could deviate when this work is carried out. "Review of the position data" and "re-teaching" will be required.

5.3.1 Robot arm structure

An outline structure drawing of the 5-axis type robot arm is shown in Fig. 5-2, and of the 6-axis type robot arm in Fig. 5-3. Each part is as shown below.

- 1) The J1 axis rotation is driven by the J1 axis motor <1> and reduction gears <2> arranged in the base.
Non-excitation magnetic brakes are mounted in the J1 axis motor <1>.
- 2) The J2 axis rotation is driven by the J2 axis motor <3> and reduction gears <4> arranged in the shoulder.
Non-excitation magnetic brakes are mounted in the J2 axis motor <3>.
- 3) The J3 axis rotation is driven by the J3 axis motor <5> and reduction gears <6> arranged in the shoulder.
Non-excitation magnetic brakes are mounted in the J3 axis motor <5>.
- 4) The rotation of the J4 axis motor <7> arranged in the elbow block is conveyed to the reduction gears <9> via the timing belt <8> to rotate the forearm and following parts. (6-axis type only)
The J4 axis brake
 - RV-3SQ series: The J4 axis motor <7> is not equipped with a Non-excitation magnetic brake.
- 5) The rotation of the J5 axis motor <10> arranged in the forearm is conveyed to the reduction gears <12> via the timing belt <11> to rotate the wrist housing and following parts.
Non-excitation magnetic brakes are mounted in the J5 axis motor <10>.
- 6) The rotation of the J6 axis is driven by the J6 axis motor <13> arranged in the wrist housing and the reduction gears <13>.
The J6 axis brake
 - RV-3SQ series: The J6 axis motor <13> is not equipped with a Non-excitation magnetic brake.

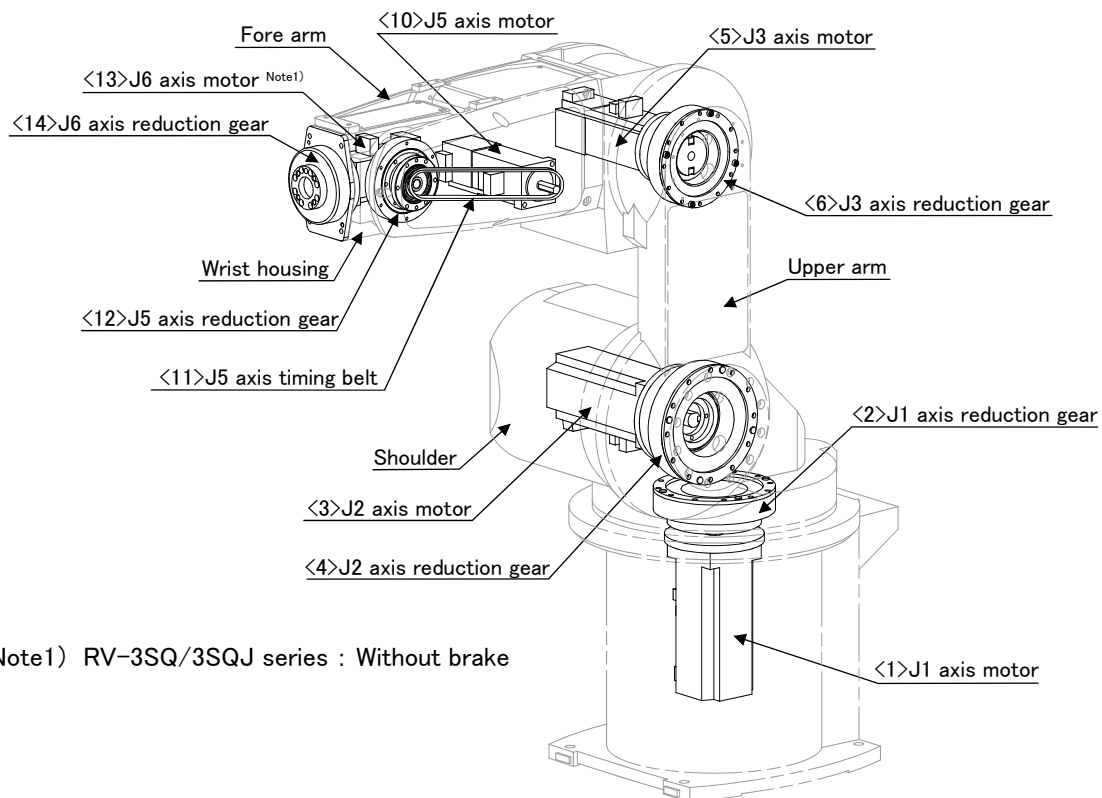

Fig.5-2 : Outline structure drawing of robot arm (5-axis type)

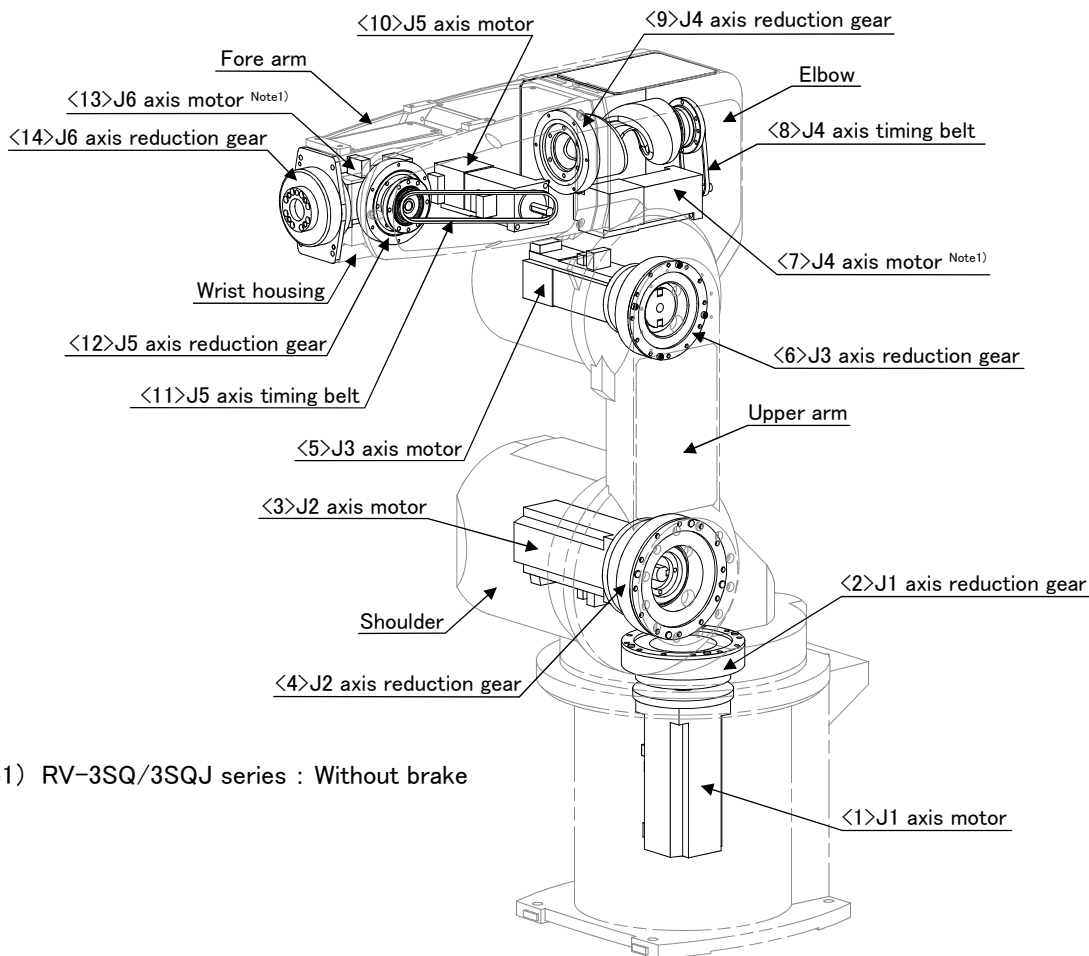

Fig.5-3 : Outline structure drawing of robot arm (6-axis type)

5.3.2 Installing/removing the cover

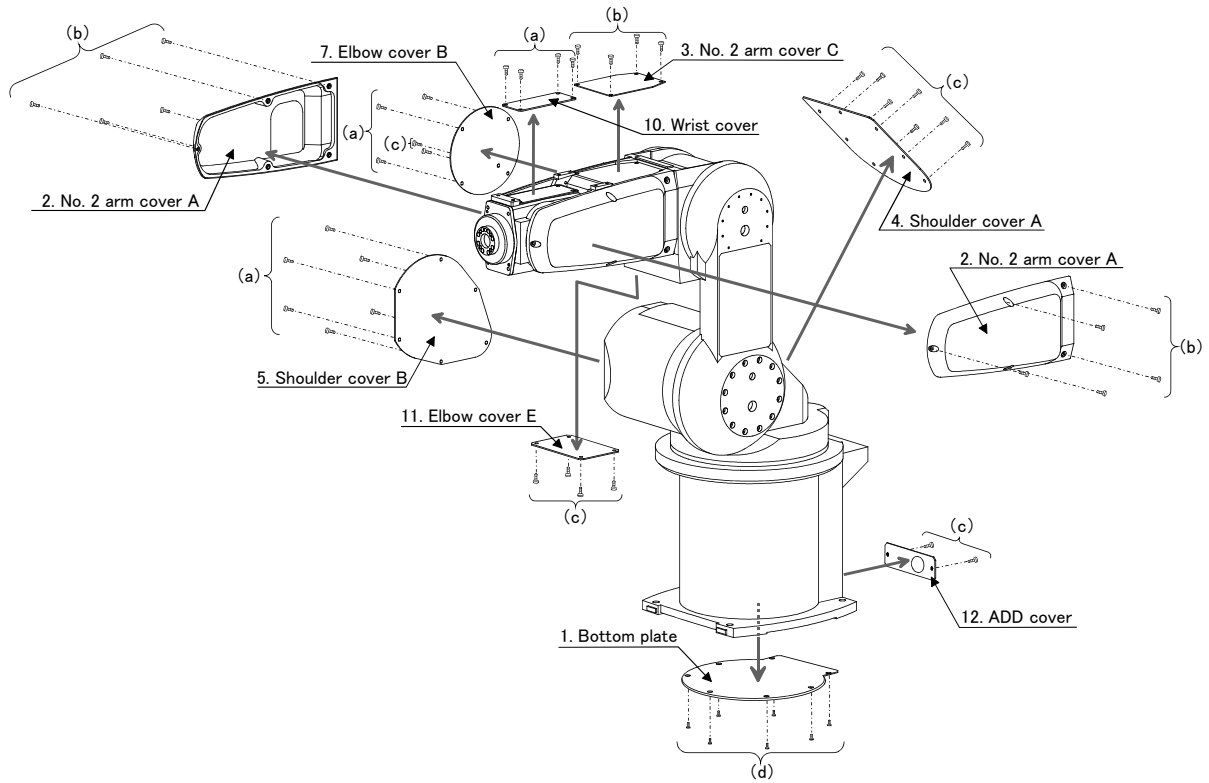

Fig.5-4 : Installing/removing the cover (5-axis type)

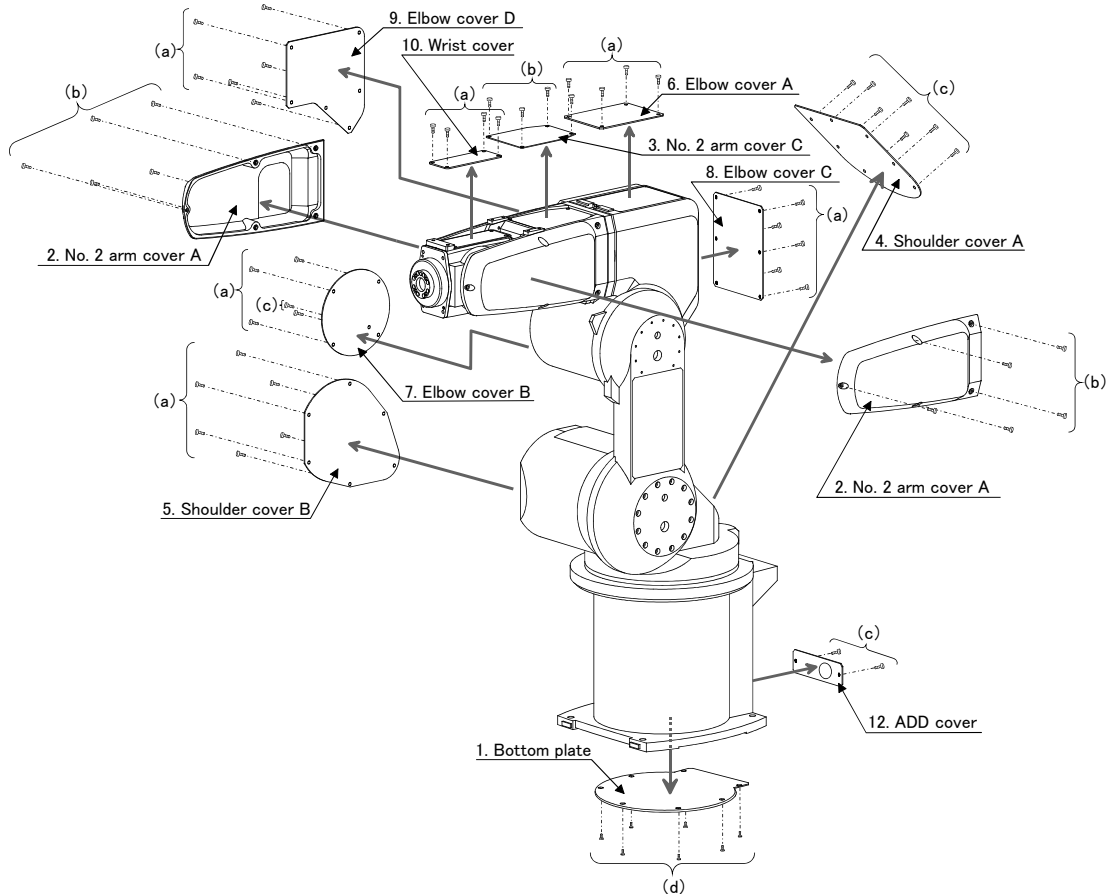

Fig.5-5 : Installing/removing the cover (6-axis type)

Table 5-3 : Cover names

No.	Cover names	Qty.		Remarks
		5 axis type	6 axis type	
①	Bottom plate	1	1	The packing is attached to the robot arm side.
②	No. 2 arm cover A	2	2	With NO2 arm cover packing
③	No. 2 arm cover C	1	1	The packing is attached to the robot arm side.
④	Shoulder cover A	1	1	With shoulder A packing
⑤	Shoulder cover B	1	1	With shoulder B packing T, shoulder B packing B
⑥	Elbow cover A	0	1	With elbow A packing L, elbow A packing R
⑦	Elbow cover B	1	1	With elbow A packing
⑧	Elbow cover C	0	1	With elbow C packing
⑨	Elbow cover D	0	1	With elbow D packing T, elbow D packing B
⑩	Elbow cover E	1	0	With elbow E packing F, elbow E packing B
⑪	Wrist cover	1	1	The packing is attached to the robot arm side.
⑫	ADD cover	1	1	With packing A

Note) This robot has packing. Refer to "Table 5-7 : Spare parts list" on page 68 for type name of packing.

Table 5-4 : Cover installation screw list

No.	Installation screw name	Qty.		Remarks
		5 axis type	6 axis type	
(a)	Truss screw M4x8	1 4	3 0	
(b)	Socket bolt (Safety socket) M4x8	1 4	1 4	
(c)	Socket bolt M4x10	1 4	1 0	With the seal washer
(d)	Flat head screw M4x8	7	7	

- (1) Refer to Fig. 5-4 when using the 5-axis type robot arm, and Fig. 5-5 when using the 6-axis type robot arm, and remove the cover.
- (2) The names of the covers are given in Table 5-3, and a list of the cover installation screws is given in Table 5-4.
- (3) There are some covers that may be difficult to remove due to the robot posture. In this case, change the robot posture with jog operation, and then remove the cover. If the minus driver is inserted, it will be easy to remove the cover. Be careful not to damage packing.
- (4) When attaching the cover after maintenance and inspection, use the detaching procedure in reverse.

The part Nos. and symbols in Table 5-3 and Table 5-4 correspond to Fig. 5-4 and Fig. 5-5.



CAUTION

Check to see that the packing has not been torn or peeled off when the cover was mounted/removed. If it has been torn or peeled off, please contact your nearest Mitsubishi Electric System & Service office (please refer to the back side of this Standard Specifications Manual for the contact information). If the cover is used with the packing torn or peeled off, oil mist and other substances may enter inside the arm and cause a malfunction.

5.3.3 Inspection, maintenance and replacement of timing belt

This robot uses a timing belt for the drive conveyance system of the J5 axis. Compared to gears and chains, the timing belt does not require lubrication and has a low noise. However, if the belt usage method and tension adjustment are inadequate, the life could drop and noise could be generated. Sufficient aging to remove the initial elongation of the belt, and adjustment of the belt tension have been carried out before shipment from the factory.

However, depending on the robot working conditions, elongation will occur gradually over a long time. The tension must be confirmed during the periodic inspection. The timing belt must be replaced in the following cases.

In addition, it is serviceable if there is the sound wave type belt tension gauge in inspection and adjustment of the timing belt. The recommendation gauge is shown below. Please prepare by customer. Refer to the "[\(4\)Timing belt tension](#)" on [page 63](#) for the tension adjustment value of the timing belt.

Maker:Gates Unitta Asia Company,

Type:U-505

(1) Timing belt replacement period

The timing belt life is greatly affected by the robot working conditions, so a set time cannot be given. However, if the following symptoms occur, replace the belt.

- 1) When cracks form at the base or back of the belt teeth.
- 2) When the belt expands due to adherence of oil, etc.
- 3) When the belt teeth wear (to approx. half of the tooth width).
- 4) When the belt teeth jump due to belt teeth wear.
- 5) When the belt snaps.



CAUTION

Due to the manufacturing of the timing belt, initial wear will occur. Wear chips may accumulate in the cover after approx. 300 Hr of operating the robot, but this is not a fault. If the wear chips appear soon after wiping them off, replace the belt.



CAUTION

When the belt is replaced, the machine system origin may deviate. In this case, the position data must be reviewed.

(2) Inspection, maintenance and replacement of J4 axis timing belt (6-axis only)

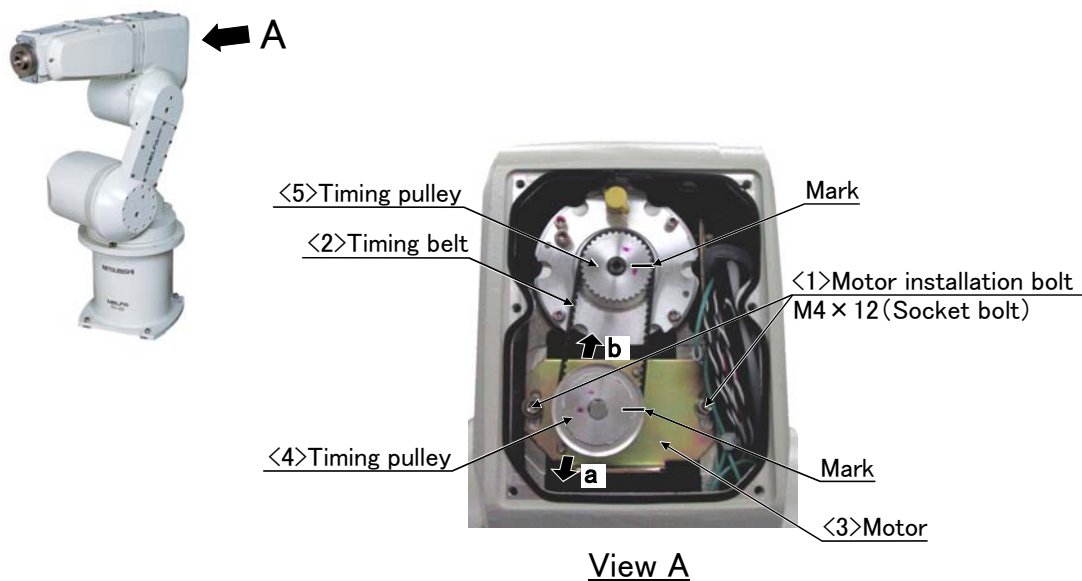

Fig.5-6 : Inspection, maintenance and replacement of J4 axis timing belt

■ Inspecting the J4 axis timing belt

- 1) Confirm that the robot controller power is OFF.
- 2) Refer to "5.3.2 Installing/removing the cover" on page 58, and remove the Elbow cover C.
- 3) Visually confirm that the symptoms indicated in "(1) Timing belt replacement period" have not occurred with the timing belt.
- 4) Confirm that the belt tension is adjusted to slacken approx. 0.9mm when the center of the belt is lightly pressed with a finger (approx. 1.3N) as shown in "Fig.5-8 : Belt tension".

■ Adjusting the J4 axis timing belt

- 1) Carry out steps "1)" and "2)" indicated in "■ Inspecting the J5 axis timing belt" above.
- 2) Lightly loosen the two motor installation bolts <1>. (Do not loosen too much.)
- 3) Move the motor <3> in the directions of the arrows shown in Fig. 5-7, using the tension adjustment screw while checking the tension of the timing belt <2>. Lightly pushing the center of the belt with your finger (approximately 1.3 N), move the motor to the position where the belt flexes about 0.9 mm.
- 4) The belt tension will increase when moved in the direction of arrow "a", and will decrease when moved in the direction of arrow "b".
- 5) If the belt is loosened too much when adjusting the tension causing it to come off the timing pulleys <4> and <5>, or if the belt and pulley teeth engagement is deviated, the machine system's origin will deviate.
- 6) After adjusting, securely tighten the two motor installation bolts <1>. Improper tightening can cause the belt to loosen with vibration.

■ Replacing the J4 axis timing belt

- 1) Fig. 5-7 shows the methods for inspecting, adjusting and replacing the timing belt.
- 2) Make sure that the pulleys do not move while replacing the belt.
- 3) If the pulley <4> and <5> position relation deviates, the position could deviate.
- 4) Make marks on the timing belt <2> and timing pulleys <4> and <5> with a felt-tip pen as shown in Fig. 5-7 so that the engagement of the timing belt <2> and timing pulleys <4> and <5> does not deviate.
- 5) Loosen the two motor installation screws <1>, and remove the belt.
- 6) Copy the marks onto the new timing belt. Make sure that both belts are tense when making the marks.
- 7) Align the new timing belt with the marks on the timing pulleys <4> and <5>, and install.
- 8) Refer to steps "3)" to "6)" in "■ Adjusting the J5 axis timing belt" and "(4) Timing belt tension" to adjust the tension.
- 9) The position could deviate after the belt is replaced. Confirm that the position has not deviated. If deviated, refer to "5.5 Resetting the origin" on page 69, and reset the origin position.

(3) Inspection, maintenance and replacement of J5-axis timing belt

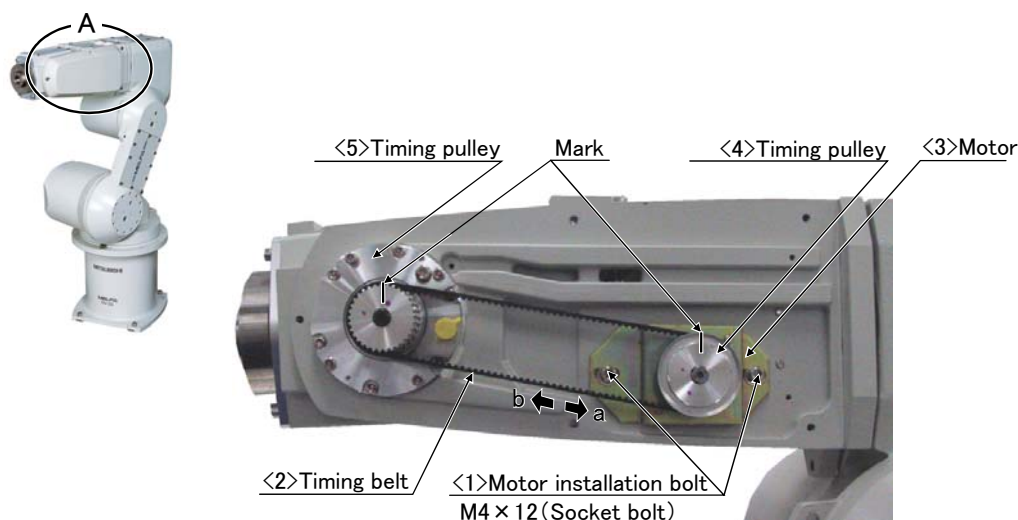

Detail of section A

Fig.5-7 : Inspection, maintenance and replacement of J5-axis timing belt

■ Inspecting the J5 axis timing belt

- 1) Confirm that the robot controller power is OFF.
- 2) Refer to "5.3.2 Installing/removing the cover" on page 58, and remove the No. 2 arm cover A (on the right side facing the robot).
- 3) Visually confirm that the symptoms indicated in "(1) Timing belt replacement period" have not occurred with the timing belt.
- 4) Confirm that the belt tension is adjusted to slacken approx. 2.3mm when the center of the belt is lightly pressed with a finger (approx. 1.3N) as shown in "Fig.5-8 : Belt tension".

■ Adjusting the J5 axis timing belt

- 1) Carry out steps "1)" and "2)" indicated in "■ Inspecting the J5 axis timing belt" above.
- 2) Lightly loosen the two motor installation bolts <1>. (Do not loosen too much.)
- 3) Move the motor <3> in the directions of the arrows shown in Fig. 5-7, using the tension adjustment screw while checking the tension of the timing belt <2>. Lightly pushing the center of the belt with your finger (approximately 1.3 N), move the motor to the position where the belt flexes about 2.3 mm.
- 4) The belt tension will increase when moved in the direction of arrow "a", and will decrease when moved in the direction of arrow "b".
- 5) If the belt is loosened too much when adjusting the tension causing it to come off the timing pulleys <4> and <5>, or if the belt and pulley teeth engagement is deviated, the machine system's origin will deviate.
- 6) After adjusting, securely tighten the two motor installation bolts <1>. Improper tightening can cause the belt to loosen with vibration.

■ Replacing the J5 axis timing belt

- 1) Fig. 5-7 shows the methods for inspecting, adjusting and replacing the timing belt.
- 2) Move the robot posture with the teaching pendant so that the J5 axis may be downward. (Turn it to the direction of gravity.)
- 3) Make sure that the pulleys do not move while replacing the belt.
- 4) If the pulley <4> and <5> position relation deviates, the position could deviate.
- 5) Make marks on the timing belt <2> and timing pulleys <4> and <5> with a felt-tip pen as shown in Fig. 5-7 so that the engagement of the timing belt <2> and timing pulleys <4> and <5> does not deviate.
- 6) Loosen the two motor installation screws <1>, and remove the belt.
- 7) Copy the marks onto the new timing belt. Make sure that both belts are tense when making the marks.
- 8) Align the new timing belt with the marks on the timing pulleys <4> and <5>, and install.
- 9) Refer to steps "3)" to "6)" in "■ Adjusting the J5 axis timing belt" and "(4) Timing belt tension" to adjust the tension.
- 10) The position could deviate after the belt is replaced. Confirm that the position has not deviated. If deviated, refer to "5.5 Resetting the origin" on page 69, and reset the origin position.

(4) Timing belt tension

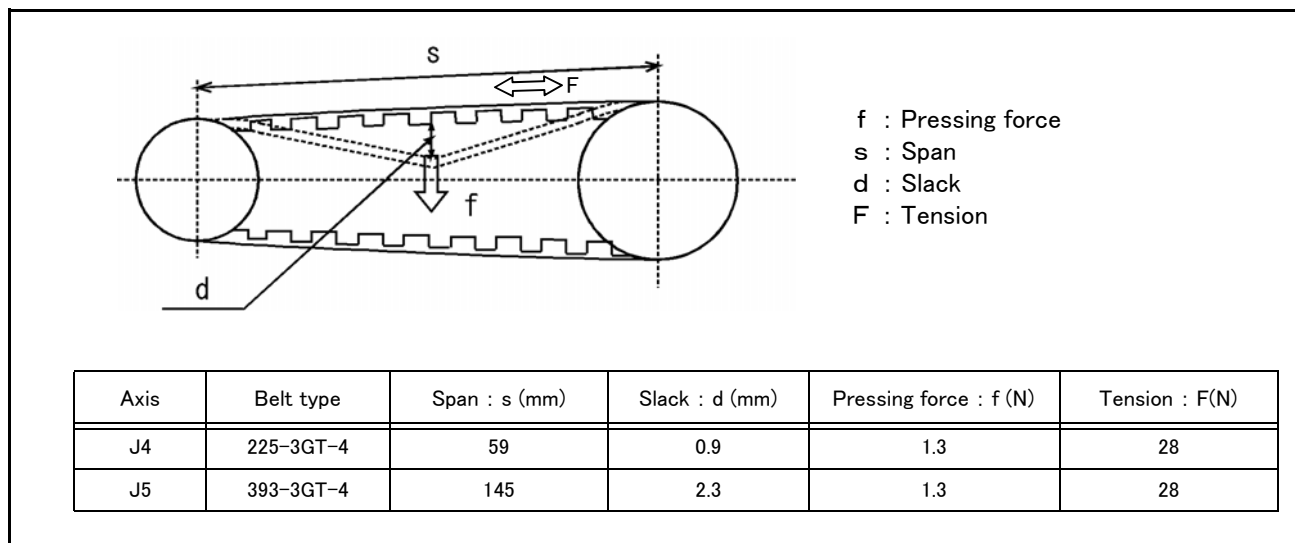

Fig.5-8 : Belt tension

The timing belt can satisfactorily convey the drive and keep a durable force only when it has an adequate tension. The belt tension should not be too tight or too loose. Instead, it should be adjusted to a degree that elasticity is felt when the belt is pressed with the thumb. If the belt tension is too weak, the belt loosening side will vibrate. On the other hand, if the belt tension is too strong, a sharp sound will be heard and the belt tension side will vibrate.

The detailed adjustment (tension) is shown in Fig. 5-8.

Check and adjust with the belt pressing force f and the slack amount d between span s .

5.3.4 Lubrication

(1) Lubrication position and specifications

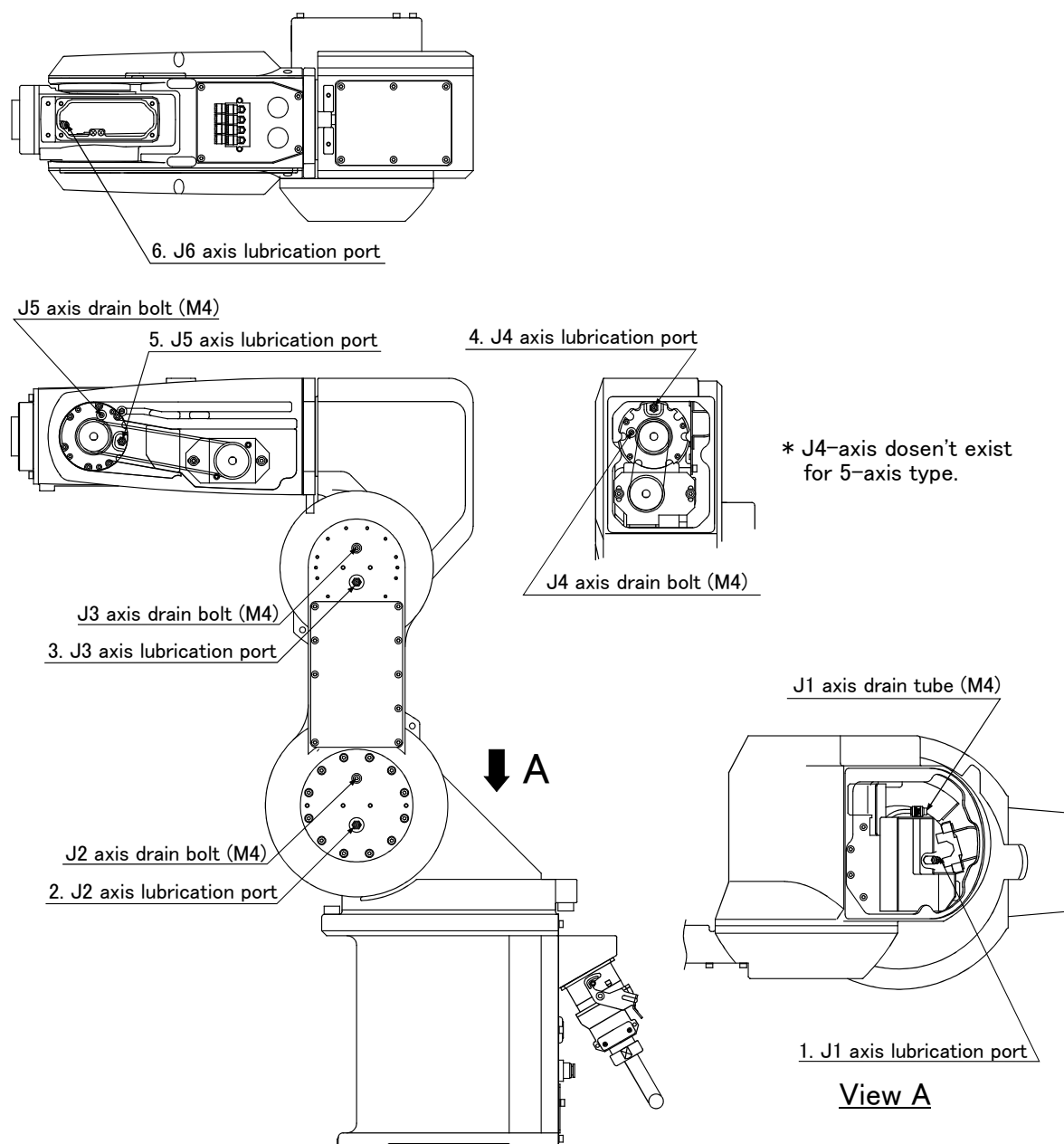

Fig.5-9 : Lubrication positions

Table 5-5 : Lubrication specifications

No.	Parts to be lubricated	Oiling method	Lubrication oil (maker)	Default charge amount	Lubrication interval	Lubrication amount	Cover to remove
1	J1 axis reduction gears	Grease nipple WB-610	Grease Harmonic grease SK-1A (Japan Harmonic Systems)	4.3ml(40g)	6,000Hr	8.7ml(8g)	Shoulder cover A
2	J2 axis reduction gears	Grease nipple WA-610		4.3ml(40g)		8.7ml(8g)	
3	J3 axis reduction gears			1.7ml(16g)		5.4ml(5g)	
4	J4 axis reduction gears (6-axis type only)			6.0mk(5.5g)		1.1ml(1g)	Elbow cover C
5	J5 axis reduction gears			6.0mk(5.5g)		1.1ml(1g)	No.2 arm cover A
6	J6 axis reduction gears	Grease nipple WB-610		1.1ml(10g)		2.2ml(2g)	Wrist cover

The lubrication specifications for each place are shown in Fig. 5-5.

[Caution]

- The brands of grease given in Table 5-5 are those filled when the robot is shipped.
- The lubrication time is a cumulative value of the operation at the maximum speed. If the operation has been suspended, or if the designated speed is slow, the lubrication time can be lengthened in proportion. (The "Lubrication interval" in Table 5-5 is usually based on the three-year inspection. 8Hr x 20 days x 36 months = 6,000Hr.)
- Depending on the robot operation state, the lubrication time will fluctuate, so determine the time according to the state so that the grease does not run out.
- With the maintenance forecast function of the personal computer support software (option), the guidance of lubrication time is calculated according to the operating environment of the customer.
- The numbers in the Table 5-5 correspond to the supply positions in Fig. 5-9.
- Avoid excessive lubrication since it may lead to grease leak. Also, the number of lubrications is limited to 3 times.

(2) Lubrication method

- 1) Set the robot to the posture shown in Fig. 5-9.
- 2) Refer to the "5.3.2 Installing/removing the cover" on page 58 and remove the covers.
- 3) Remove the drain bolt or plug of J1 to J5. (About the J6 axis, removing is unnecessary.)
- 4) Insert the grease shown in Table using a grease gun from the lubrication grease nipple.
- 5) Install the drain bolt or plug of J1 to J5.
- 6) Replace the covers with the removal procedure in reverse.

 CAUTION

When lubricating axes that require removal of air bleed bolts and plugs (axes J1 to J5 on products affected by the change, or all axes on other products), always remove the applicable bolts and plugs prior to lubrication. If these bolts and plugs remain installed during lubrication, the seals of the reduction gears may be damaged, causing grease to leak or the product to malfunction.

 CAUTION

Use manual grease gun, and inject grease with pressure 0.03Mpa or less. Do not use the grease gun, which derived by the factory air presser to avoid injecting by too high pressure.

5.3.5 Replacing the backup battery

An absolute encoder is used for the position detector, so the position must be saved with the backup battery when the power is turned OFF. The controller also uses a backup battery to save the program, etc. These batteries are installed when the robot is shipped from the factory, but as these are consumable parts, they must be replaced periodically by the customer.

The guideline for replacing the battery is one year, but this will differ according to the robot's usage state.

Error No. 7520 :Battery consumption time is over

Error No. 133n :Encoder battery voltage low. (n indicates the axis number.)

(The encoder battery voltage of the robot arm is low.)

Error No. 7510 :Battery voltage low (R/C)

(The battery voltage of the controller is low.)

Error No. 7500 :No battery voltage

(The battery of the controller is depleted.)



CAUTION

If error No. 7500 occurs, the program data and other data in the controller is lost and it becomes necessary to load the data again.

If any of the battery-related errors above occur and the robot continues to be used, the data integrity of the memory cannot be guaranteed. If an error occurs, replace the batteries of both the robot arm and controller promptly.

It is also recommended to save programs and position data on the personal computer side via the personal computer support software and so forth in advance.

(1) Replacing the robot arm battery

**CAUTION**

Don't disconnect connector, etc. While replacing the battery, the encoder position data is saved by the power supplied from the controller. Thus, if the cable connection is incomplete, the encoder position data will be lost when the controller power is turned OFF. Several batteries are used in the robot arm, but replace all old batteries with new batteries at the same time.

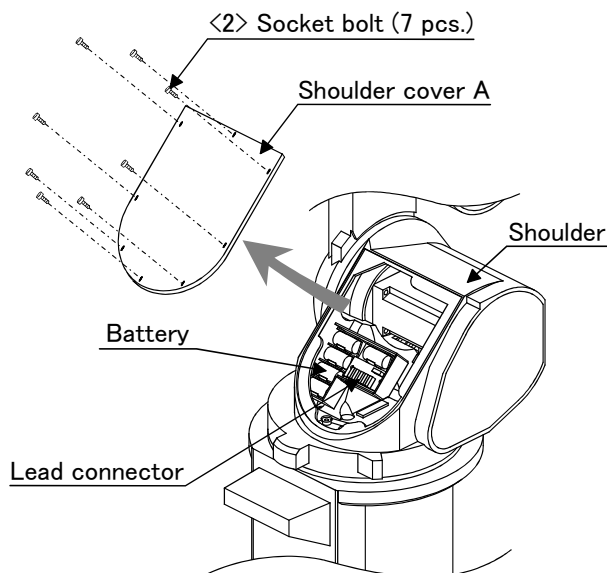

Fig.5-10 : Replacing the battery

- 1) Confirm that the robot arm and controller are connected with a cable.
- 2) Turn the controller control power ON.
The position data is retained by the power supplied from the controller while replacing the battery. Thus, if the cable is not connected correctly, or if the controller power is OFF, the position data will be lost.
- 3) Press the emergency stop button to set the robot in the emergency stop state. This is a measure for safety, and must always be carried out.
- 4) Remove the seven socket bolt <2>, and remove the shoulder cover A. (Refer to ["5.3.2 Installing/removing the cover"](#) on page 58.)
- 5) The battery holder is located in the shoulder. Remove the old battery from the holder, and disconnect the lead connector.
- 6) Insert the new battery into the holder, and connect the lead connector. Replace all batteries with new ones at the same time.
- 7) All the batteries should check that it has been exchanged newly. If the old battery is contained, generating heat and damaging may occur.
- 8) Install the shoulder cover A.
- 9) Initialize the battery consumption time.
Always carry out this step after replacing the battery, and initialize the battery usage time. Refer to the separate "Instruction Manual/Detailed Explanation of Functions and Operations" for details on the operation methods.

[Caution] If the old battery is replaced because it has been used up, it is necessary to set the origin again. Refer to ["5.5 Resetting the origin"](#) on page 69 and reset the origin using the jig method or mechanical stopper method or ABS origin method.

5.4 Maintenance parts

The consumable parts that must be replaced periodically are shown in [Table 5-6](#), and spare parts that may be required during repairs are shown in [Table 5-7](#). Purchase these parts from the dealer when required. Some Mitsubishi-designated parts differ from the maker's standard parts. Thus, confirm the part name, robot arm and controller serial No. and purchase the parts from the dealer.

Table 5-6 : Consumable part list

No.	Part name	Type ^{Note1)}	Usage place	Q'ty	Supplier
1	Timing belt		J4 axis	1	Mitsubishi Electric
2	Timing belt		J5 axis	1	
3	Grease	SK-1A	Reduction gears of each axis	An needed	
4	Lithium battery	A6BAT	In shoulder cover A Type: All axis have brake	4	
			In shoulder cover A Type: J4 and J6 have no brake	5	

Table 5-7 : Spare parts list

No.	Names	Type ^{Note1)}	Usage place	Q'ty	Supplier
1	AC servo motor		J1 axis	1	Mitsubishi Electric
2			J2 axis	1	
3			J3 axis	1	
4			J4 axis (6 axis type)	1	
5			J5 axis	1	
6			J6 axis	1	
7	Reduction gears		J1 axis	1	
8			J2 axis	1	
9			J3 axis	1	
10			5 axis type : J5 axis	1	
11			6 axis type : J4, J5 axis	2	
	5 axis type (RV-3SQJ series)				
12	shoulder A packing		Shoulder cover A	1	Mitsubishi Electric
13	shoulder B packing T		Shoulder cover A	1	
14	shoulder B packing B		Shoulder cover B	1	
15	elbow B		Shoulder cover B	1	
16	elbow E packing F		Elbow cover E	1	
17	elbow E packing B		Elbow cover E	1	
18	NO2 arm cover packing		No. 2 arm cover A	2	
19	packing		Base plate	2	
20	NO2 arm cover C packing		No. 2 arm cover C	1	
21	Wrist cover packing		Wrist cover	1	
22	ADD packing		ADD cover	1	
23	Seal washer		ADD cover, Shoulder cover A, Elbow cover B, Elbow cover E	1 4	
	6 axis type (RV-3SQ series)				
24	Shoulder A packing		Shoulder cover A	1	Mitsubishi Electric
25	Shoulder B packing T		Shoulder cover B	1	
26	Shoulder B packing B		Shoulder cover B	1	
27	Elbow D packing T		Elbow cover D	1	
28	Elbow D packing B		Elbow cover D	1	
29	Elbow C packing		Elbow cover C	1	
30	Elbow B packing		Elbow cover C	1	
31	Elbow A packing L		Elbow cover A	1	
32	Elbow A packing R		Elbow cover A	1	
33	No. 2 arm packing		No. 2 armcover A	2	
34	packing		Base plate	2	
35	No. 2 armcover C packing		No. 2 armcover C	1	
36	Wrist cover packing		Wrist cover	1	
37	ADD packing		ADD cover	1	
38	Seal washer		ADD cover, Shoulder cover A, Elbow cover B, Elbow cover E	1 0	

Note1) Confirm the robot arm serial No., and contact the dealer or service branch of Mitsubishi Electric Co., for the type.

5.5 Resetting the origin

The origin is set so that the robot can be used with a high accuracy. After purchasing the robot, always carry out this step before starting work. The origin must be reset if the combination of robot and controller being used is changed or if the motor is changed causing an encoder area. The types of origin setting methods are shown in [Table 5-8](#).

[Caution] If the old battery is replaced because it has been used up, it is necessary to set the origin again. Reset the origin using the jig method or mechanical stopper method or ABS origin method.

Table 5-8 : Origin setting method

No	Method	Explanation	Remarks
1	Origin data input method	The origin data set as the default is input from the T/B.	The setting method is explained in "2.3Setting the origin" on page 11 .
2	Mechanical stopper method	This origin posture is set by contacting each axis against the mechanical stopper.	The setting method is explained in "5.5.1Mechanical stopper method" on page 70 .
3	Jig method	The origin posture is set with the calibration jig installed.	The setting method is explained in "5.5.2Jig method" on page 86 .
4	ABS origin method	This method is used when the encoder backup data lost in the cause such as battery cutting.	Before using this method, the origin must be set with the other method with same encoder. The setting method is explained in "5.5.3ABS origin method" on page 99 .
5	User origin method	A randomly designated position is set as the origin posture.	The setting method is explained in "5.5.4User origin method" on page 101 .

5.5.1 Mechanical stopper method

The method for setting the origin with the transportation jig is explained below.

This operation is carried out with the T/B. Set the [MODE] switch on the front of the controller to "MANUAL", and set the T/B [ENABLE] switch to "ENABLE" to validate the T/B.

CAUTION

Here, if an axis is equipped with a brake, release the brake and move the arm with both hands. At this point release the brakes and move the arm with both hands. To ensure safety, the brake-release procedure described below should always be done by two persons.

(1) J1 axis origin setting (mechanical stopper)

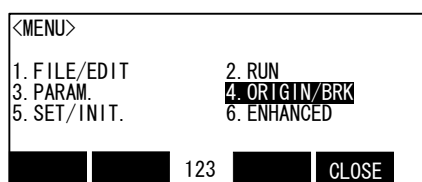

1) Press the [4] key on the menu screen, and display the Origin/BRK selection screen.

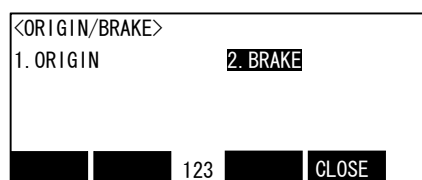

2) Press the [2] key, and display the Break release selection screen.

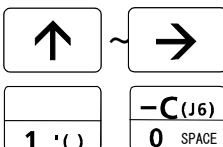
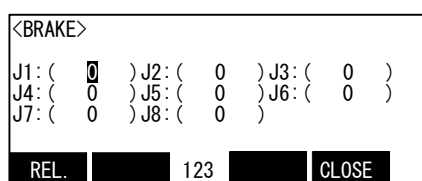

3) Release the brake of the J1 axis. Input "1" into the J1 axis. Set "0" to other axes.

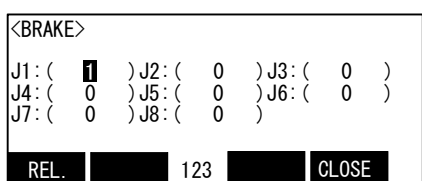

4) Confirm the axis for which the brakes are to be released.

5) Pressing the [F1] key is kept with the enabling switch of T/B pressed down. The brake is released while pressing the key.

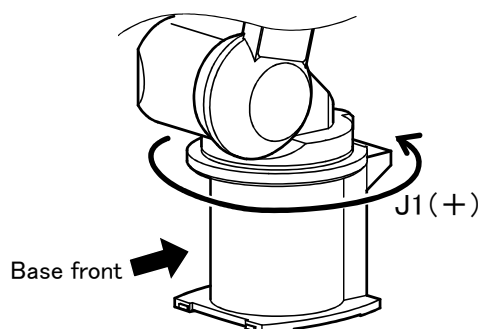

6) With both hands, slowly move the J1 axis in + (plus) direction, and contact the axis against the mechanical stopper.

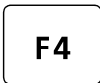
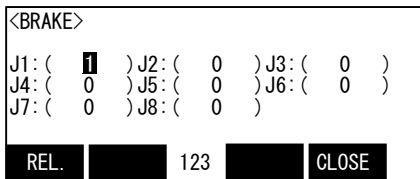

7) Detach the [F1] key and work the brake.
Press the [F4] key and return to the origin / brake screen.

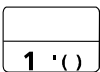
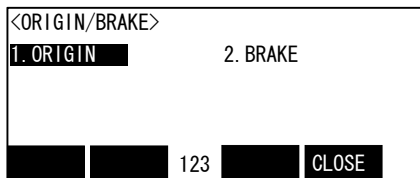

8) Press the [1] key, and display the Origin setting selection screen.

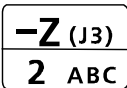
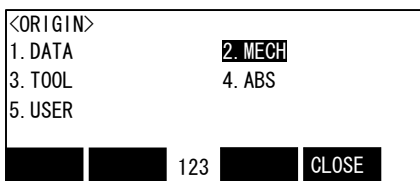

9) Press the [2] key, and display the Mechanical stopper selection screen.

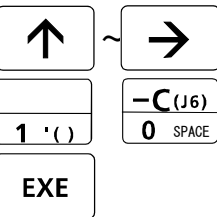
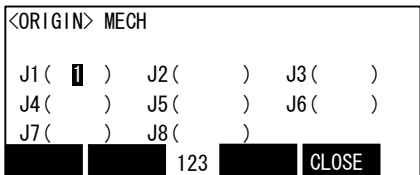

10) Input "1" into the J1 axis. Set "0" to other axes.

11) Press the [EXE] key, and display Confirmation screen.

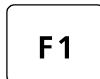
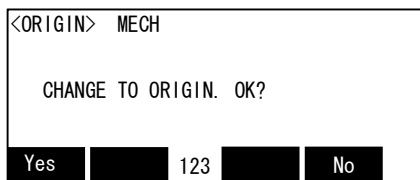

12) Press the [F1] key, and the origin position is set up.

13) Setting of the origin is completed.

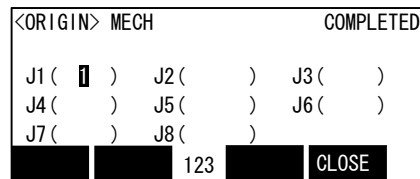

14) Refer to "5.5.5 Recording the origin data" on page 103 in this manual, and record the origin data on the origin data seal.

◆◆◆ Release the brake ◆◆◆

Do cursor movement into the parenthesis of each axis by the arrow key. The brakes can be released only for the axis for which a "1" is displayed on the screen. If the brakes are not to be released, press the [0] key and display a "0". If the [F1] key on the teaching pendant or the enabling switch is detached while the brakes are released, the brakes will be work immediately.

◆◆◆ Select the axis of origin setting ◆◆◆

Do cursor movement into the parenthesis of each axis by the arrow key. The origin is set only for the axis for which a "1" is displayed on the screen. If the origin is not to be set, press the [0] key and display a "0".

(2) J2 axis origin setting(mechanical stopper)

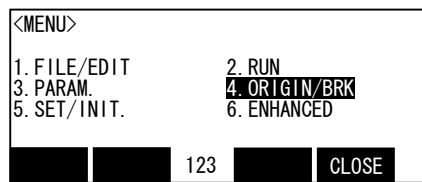

1) Press the [4] key on the menu screen, and display the Origin/BRK selection screen.

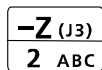
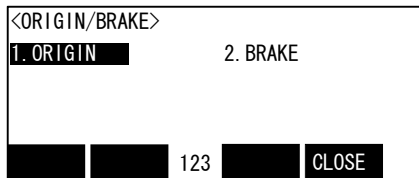

2) Press the [2] key, and display the Break release selection screen.

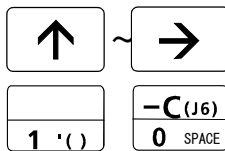
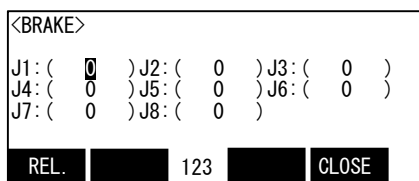

3) Release the brake of the J2 axis. Input "1" into the J2 axis. Set "0" to other axes.

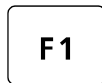
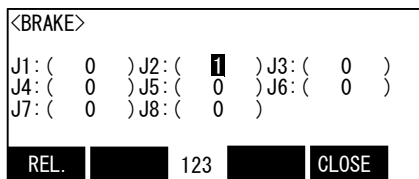

4) Confirm the axis for which the brakes are to be released.

5) Pressing the [F1] key is kept with the enabling switch of T/B pressed down. The brake is released while pressing the key.

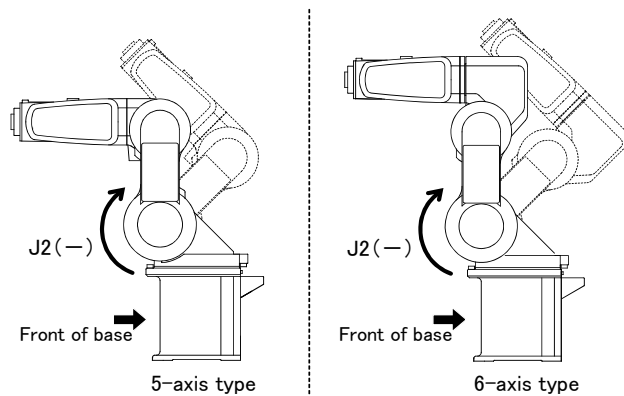

6) With both hands, slowly move the J2 axis in + (plus) direction, and contact the axis against the mechanical stopper.

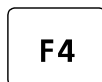
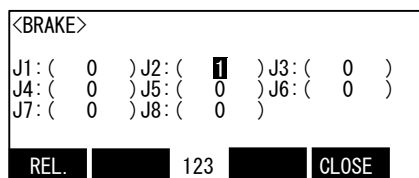

7) Detach the [F1] key and work the brake. Press the [F4] key and return to the Origin / BRK screen.

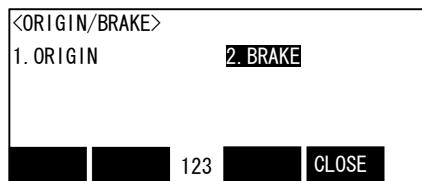

8) Press the [1] key , and display the Origin setting selection screen.

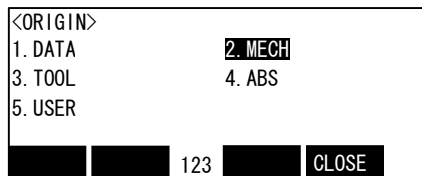
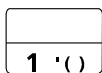

9) Press the [2] key , and display the Mechanical stopper selection screen.

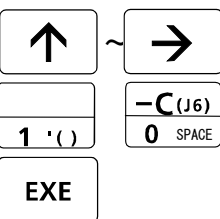
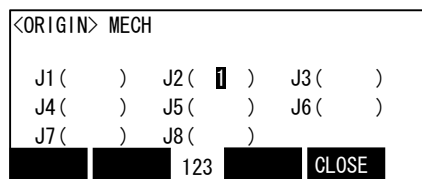
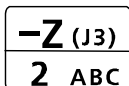

10) Input "1" into the J2 axis. Set "0" to other axes.

11) Press the [EXE] key , and display Confirmation screen.

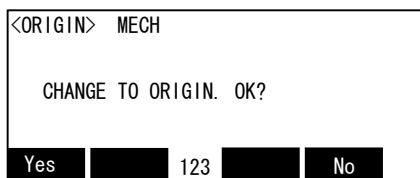

12) Press the [F1] key , and the origin position is set up.

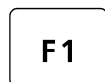

13) Setting of the origin is completed.

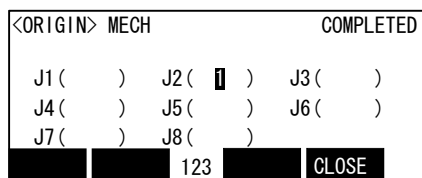

14) Refer to "5.5.5Recording the origin data" on page 103 in this manual, and record the origin data on the origin data seal.

◆◆◆ Release the brake ◆◆◆

Do cursor movement into the parenthesis of each axis by the arrow key. The brakes can be released only for the axis for which a "1" is displayed on the screen. If the brakes are not to be released, press the [0] key and display a "0". If the [F1] key on the teaching pendant or the enabling switch is detached while the brakes are released, the brakes will be work immediately.

◆◆◆ Select the axis of origin setting ◆◆◆

Do cursor movement into the parenthesis of each axis by the arrow key. The origin is set only for the axis for which a "1" is displayed on the screen. If the origin is not to be set, press the [0] key and display a "0".

(3) J3 axis origin setting(mechanical stopper)

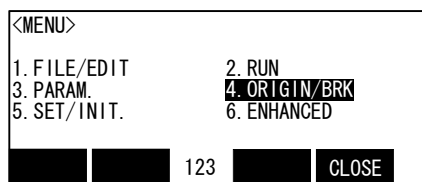

1) Press the [4] key on the menu screen, and display the Origin/BRK selection screen.

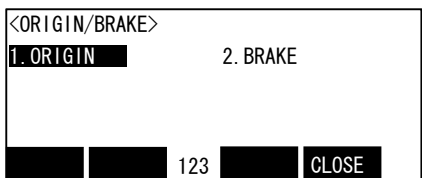

2) Press the [2] key, and display the Break release selection screen.

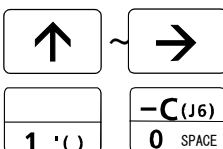
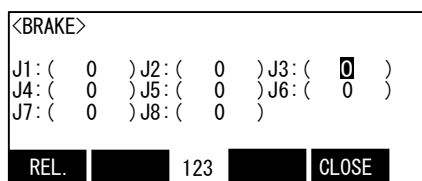

3) Release the brake of the J3 axis.
Input "1" into the J3 axis. Set "0" to other axes.

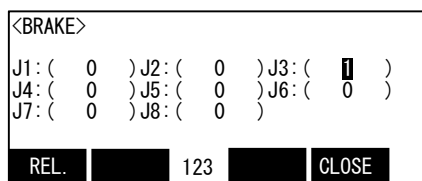

4) Confirm the axis for which the brakes are to be released.

5) Pressing the [F1] key is kept with the enabling switch of T/B pressed down. The brake is released while pressing the key.

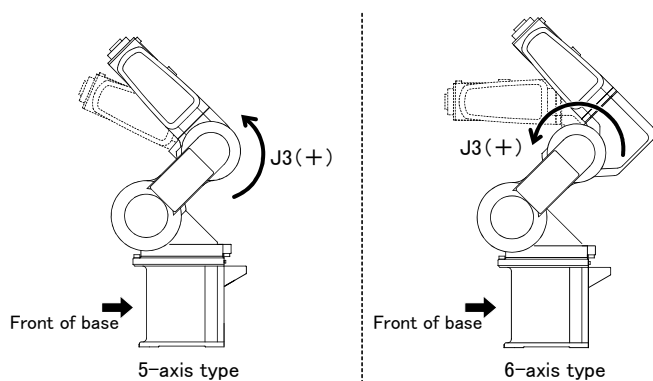

6) With both hands, slowly move the J3 axis in + (plus) direction, and contact the axis against the mechanical stopper.

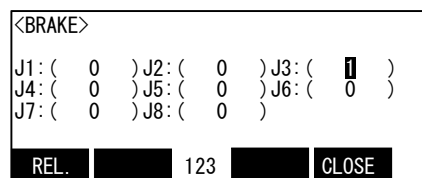

7) Detach the [F1] key and work the brake. Press the [F4] key and return to the Origin / BRK screen.

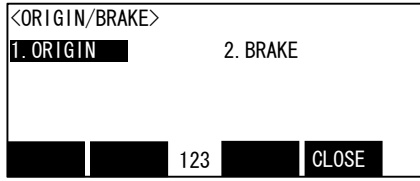

8) Press the [1] key , and display the Origin setting selection screen.

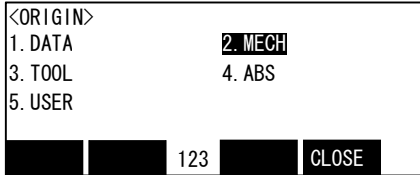
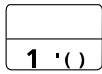

9) Press the [2] key , and display the Mechanical stopper selection screen.

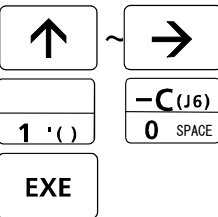
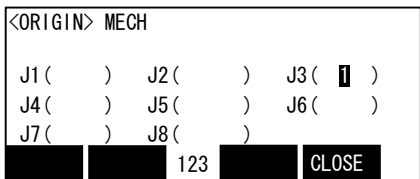
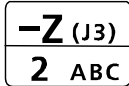

10) Input "1" into the J3 axis. Set "0" to other axes.

11) Press the [EXE] key , and display Confirmation screen.

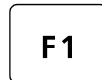
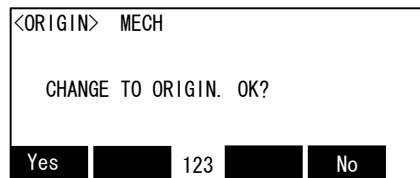

12) Press the [F1] key , and the origin position is set up.

13) Setting of the origin is completed.

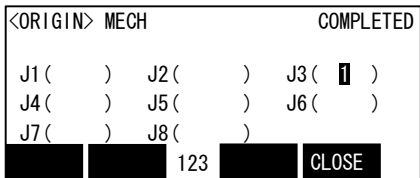

14) Refer to "5.5.5Recording the origin data" on page 103 in this manual, and record the origin data on the origin data seal.

◆◆◆ Release the brake ◆◆◆

Do cursor movement into the parenthesis of each axis by the arrow key. The brakes can be released only for the axis for which a "1" is displayed on the screen. If the brakes are not to be released, press the [0] key and display a "0". If the [F1] key on the teaching pendant or the enabling switch is detached while the brakes are released, the brakes will be work immediately.

◆◆◆ Select the axis of origin setting ◆◆◆

Do cursor movement into the parenthesis of each axis by the arrow key. The origin is set only for the axis for which a "1" is displayed on the screen. If the origin is not to be set, press the [0] key and display a "0".

(4) J4 axis origin setting(6-axis type only)(mechanical stopper)

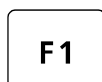
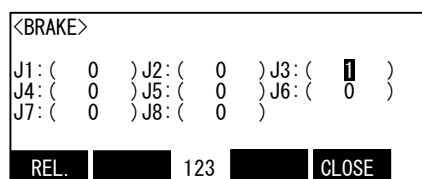
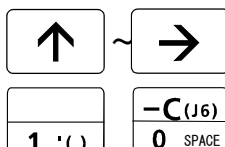
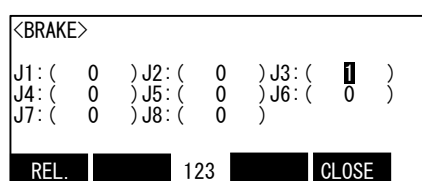
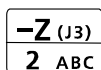
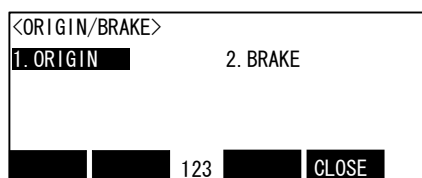
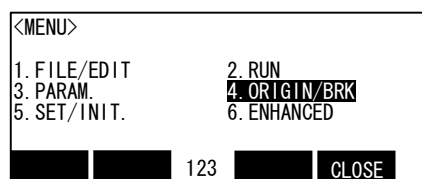

"5.5.5 Recording the origin data" on page 103

1) Press the [4] key on the menu screen, and display the Origin/BRK selection screen.

2) Press the [2] key, and display the Brake release selection screen.

3) Before moving the J4 axis, move the J3 axis to prevent arm interference.
 Input "1" into the J3 axis. Set "0" to other axes.

4) Confirm the axis for which the brakes are to be released.

5) Pressing the [F1] key is kept with the enabling switch of T/B pressed down. The brake is released while pressing the key.

6) With both hands, slowly move the J3 axis in - (minus) direction. Stop at a position where the arm will not interfere even if the J4 axis is rotated, and then apply the brakes.
 Then, set the J4 axis origin.

7) Detach the [F1] key and work the brake.

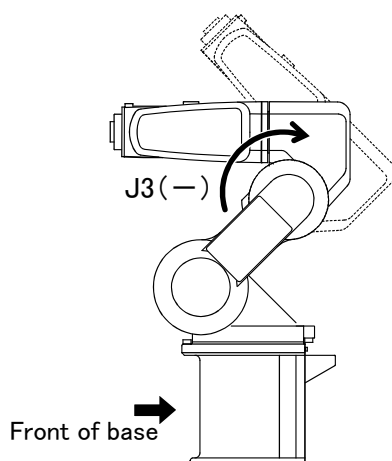

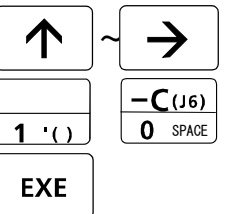
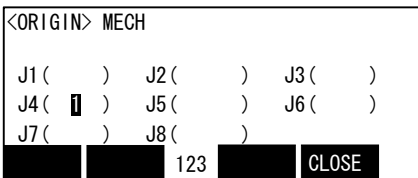
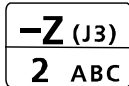
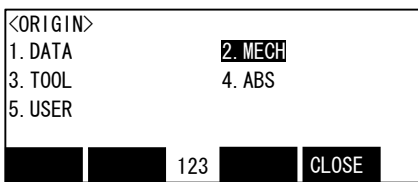
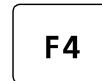
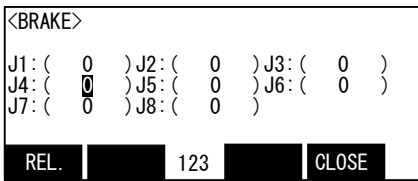
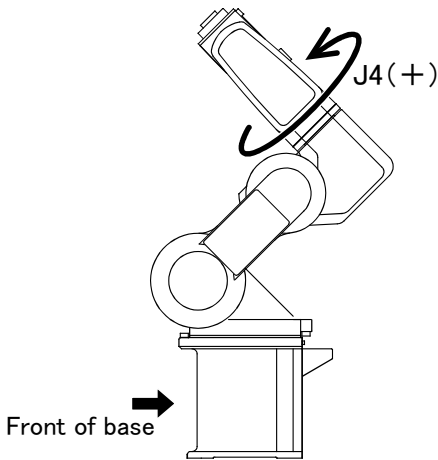
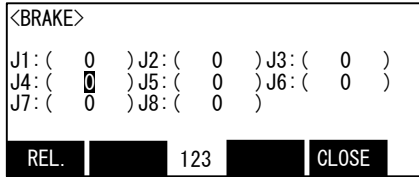
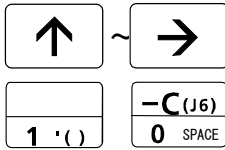
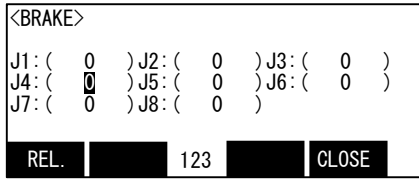

8) The type which does not have the brake in the J4 axis skips to "1." .
The type with the brake release the brake. Input "1" into the J4 axis. Set "0" to other axes.

9) Confirm the axis for which the brakes are to be released.

10) Pressing the [F1] key is kept with the enabling switch of T/B pressed down. The brake is released while pressing the key.

11) With both hands, slowly move the J4 axis in + (plus) direction , and contact the axis against the mechanical stopper.

12) Detach the [F1] key and work the brake.
Press the [F4] key and return to the Origin / BRK screen.

13) Press the [2] key , and display the Mechanical stopper selection screen.

14) Input "1" into the J4 axis. Set "0" to other axes.

15) Press the [EXE] key , and display Confirmation screen.

<ORIGIN> MECH			
CHANGE TO ORIGIN. OK?			
Yes	123	No	

F1

<ORIGIN> MECH		COMPLETED	
J1()	J2()	J3()	
J4(1)	J5()	J6()	
J7()	J8()		
	123	CLOSE	

16) Press the [F1] key , and the origin position is set up.

17) Setting of the origin is completed.

18) Refer to ["5.5.3ABS origin method"](#) on page 99 in this manual, and record the origin data on the origin data seal.

◆◆◆ Release the brake ◆◆◆

Do cursor movement into the parenthesis of each axis by the arrow key. The brakes can be released only for the axis for which a "1" is displayed on the screen. If the brakes are not to be released, press the [0] key and display a "0". If the [F1] key on the teaching pendant or the enabling switch is detached while the brakes are released, the brakes will be work immediately.

◆◆◆ Select the axis of origin setting ◆◆◆

Do cursor movement into the parenthesis of each axis by the arrow key. The origin is set only for the axis for which a "1" is displayed on the screen. If the origin is not to be set, press the [0] key and display a "0".

(5) J5 axis origin setting(mechanical stopper)

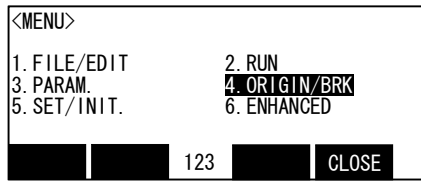

1) Press the [4] key on the menu screen, and display the Origin/BRK selection screen.

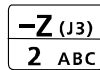
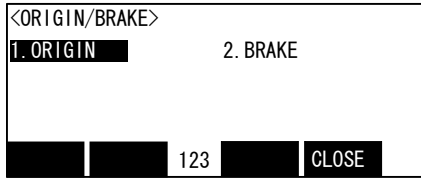

2) Press the [2] key, and display the Break release selection screen.

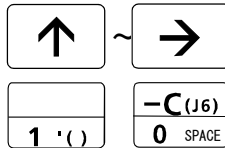
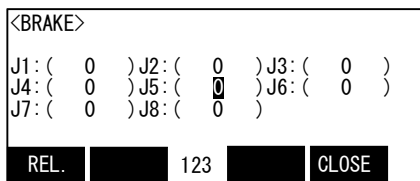

3) Release the brake of the J5 axis.
Input "1" into the J5 axis. Set "0" to other axes

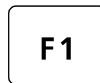
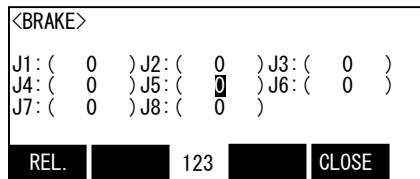

4) Confirm the axis for which the brakes are to be released.

5) Pressing the [F1] key is kept with the enabling switch of T/B pressed down. The brake is released while pressing the key.

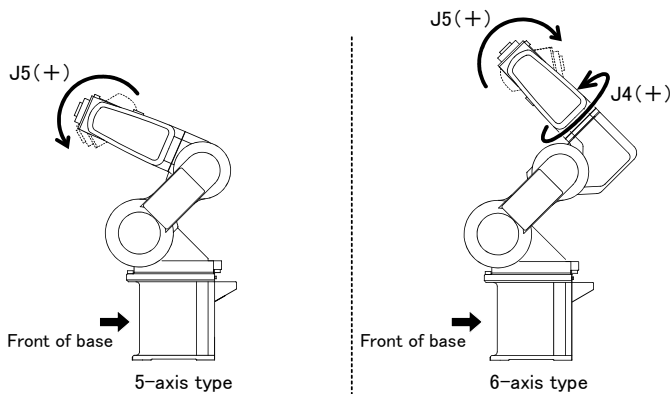

* The 6 axis type direction of J5 axis shows the case where the J4 axis is in the mechanical stopper position.

6) With both hands, slowly move the J5 axis in + (plus) direction, and contact the axis against the mechanical stopper.

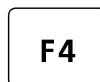
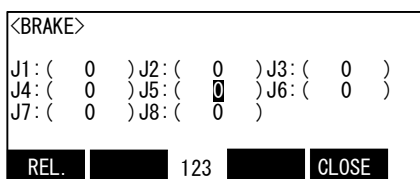

7) Detach the [F1] key and work the brake. Press the [F4] key and return to the Origin / BRK screen.

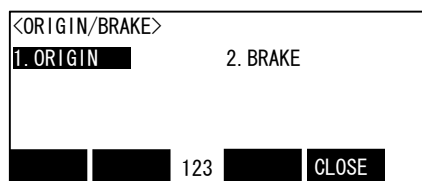

8) Press the [1] key , and display the Origin setting selection screen.

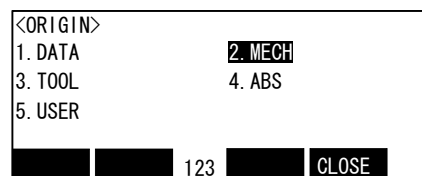
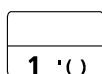

9) Press the [2] key , and display the Mechanical stopper selection screen.

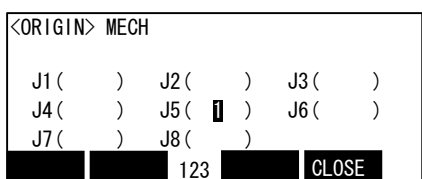
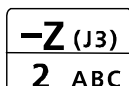

10) Input "1" into the J5 axis. Set "0" to other axes.

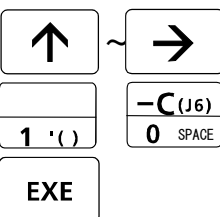

11) Press the [EXE] key , and display Confirmation screen.

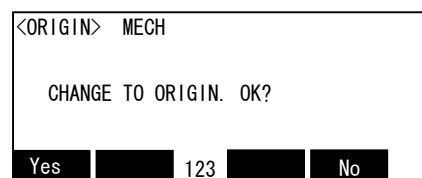

12) Press the [F1] key , and the origin position is set up.



13) Setting of the origin is completed.

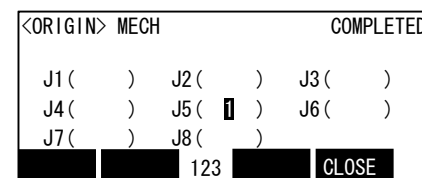

14) Refer to "5.5.3ABS origin method" on page 99 in this manual, and record the origin data on the origin data seal.

◆◆◆ Release the brake ◆◆◆

Do cursor movement into the parenthesis of each axis by the arrow key. The brakes can be released only for the axis for which a "1" is displayed on the screen. If the brakes are not to be released, press the [0] key and display a "0". If the [F1] key on the teaching pendant or the enabling switch is detached while the brakes are released, the brakes will be work immediately.

◆◆◆ Select the axis of origin setting ◆◆◆

Do cursor movement into the parenthesis of each axis by the arrow key. The origin is set only for the axis for which a "1" is displayed on the screen. If the origin is not to be set, press the [0] key and display a "0".

(6) J6 axis origin setting(mechanical stopper)

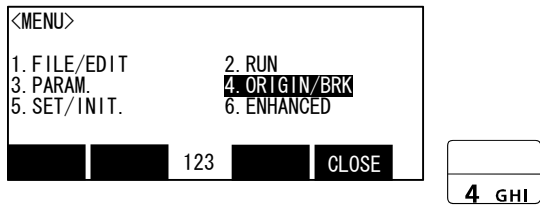

- 1) Install the bolts (two M5 bolts prepared by customer) at opposing positions on the mechanical interface.
- 2) Press the [4] key on the menu screen, and display the Origin/BRK selection screen.

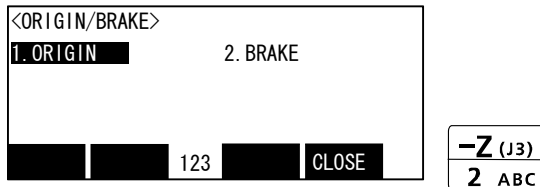

- 3) Press the [2] key, and display the Break release selection screen.

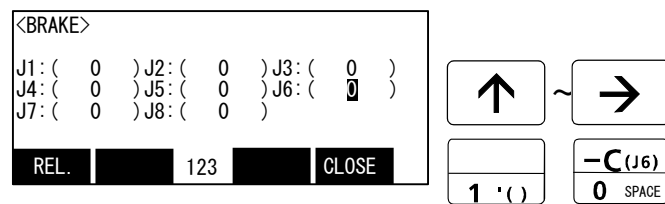

- 4) The type which does not have the brake in the J6 axis skips to "7." .
The type with the brake release the brake. Input "1" into the J6 axis. Set "0" to other axes.

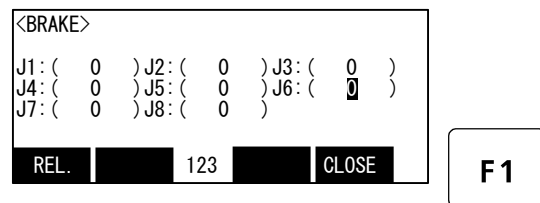

- 5) Confirm the axis for which the brakes are to be released.

- 6) Pressing the [F1] key is kept with the enabling switch of T/B pressed down. The brake is released while pressing the key.

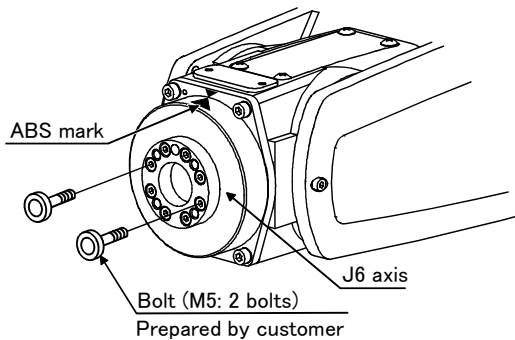

- 7) Hold the bolts mounted in step "1)" above with hands, rotate them slowly and align the ABS mark of the J6 axis with the ABS mark of the wrist area.

CAUTION The J6-axis dose not have a mechanical stopper. When setting the origin position, do not rotate the axis more than themotion range(± 200 deg.).

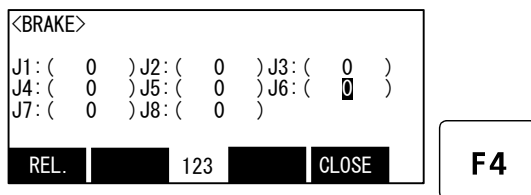

- 8) Detach the [F1] key and work the brake. Press the [F4] key and return to the Origin / BRK screen.

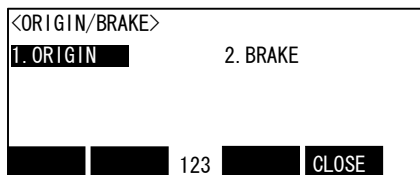

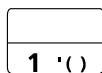
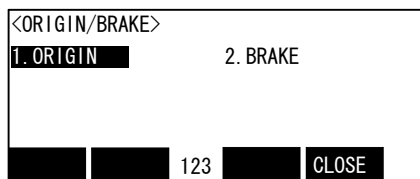

9) Press the [1] key , and display the Origin setting selection screen.

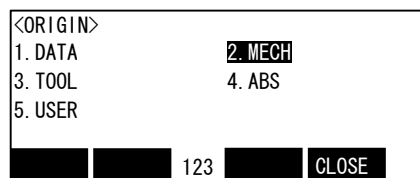

10) Press the [2] key , and display the Mechanical stopper selection screen.

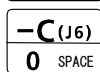
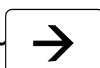
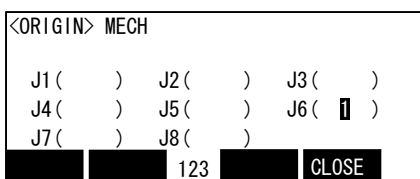

11) Input "1" into the J6 axis. Set "0" to other axes.



12) Press the [EXE] key , and display Confirmation screen.

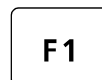
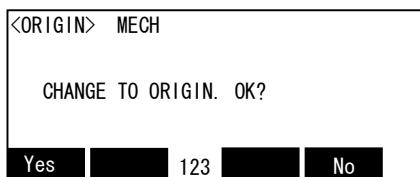

13) Press the [F1] key , and the origin position is set up.

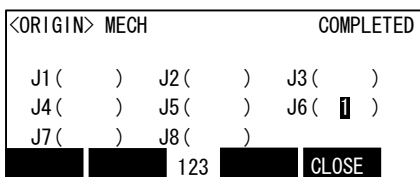

14) Setting of the origin is completed.

15) Refer to "5.5.3ABS origin method" on page 99 in this manual, and record the origin data on the origin data seal.

◆◆◆ Release the brake ◆◆◆

Do cursor movement into the parenthesis of each axis by the arrow key. The brakes can be released only for the axis for which a "1" is displayed on the screen. If the brakes are not to be released, press the [0] key and display a "0". If the [F1] key on the teaching pendant or the enabling switch is detached while the brakes are released, the brakes will be work immediately.

◆◆◆ Select the axis of origin setting ◆◆◆

Do cursor movement into the parenthesis of each axis by the arrow key. The origin is set only for the axis for which a "1" is displayed on the screen. If the origin is not to be set, press the [0] key and display a "0".

(7) All axis origin setting

■ In the case of the 5-axis type

- 1) Refer to the paragraphs from “(1)J1 axis origin setting(mechanical stopper)” on page 70 to “(6)J6 axis origin setting(mechanical stopper)” on page 81 above for the description of how to adjust the origins of the J1 to J6 axes. Line up the ABS marks for the J6 axis and move the other axes into contact with the mechanical stoppers. At this point, the robot will have the posture shown below

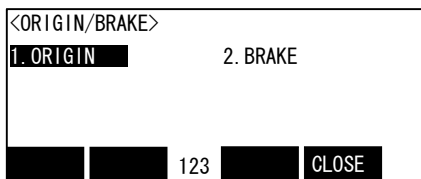
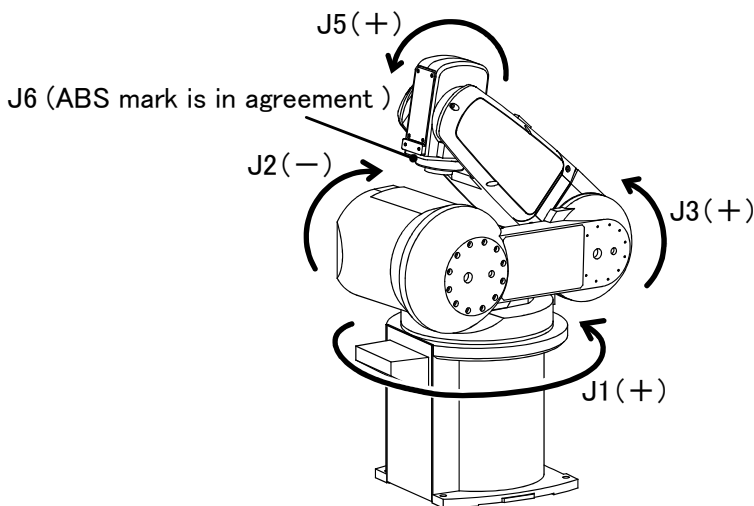

- 2) Press the [1] key , and display the Origin setting selection screen.

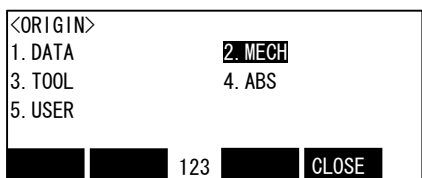
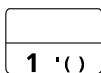

- 3) Press the [2] key , and display the Mechanical stopper selection screen.

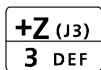

- 4) Input “1” into the J1 to J6 axis. Set “0” to other axes.

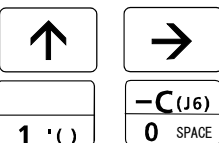

- 5) Press the [EXE] key , and display Confirmation screen.

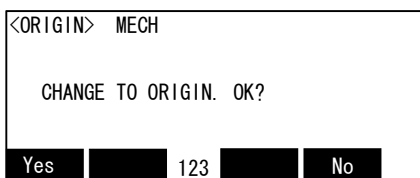

- 6) Press the [F1] key , and the origin position is set up.

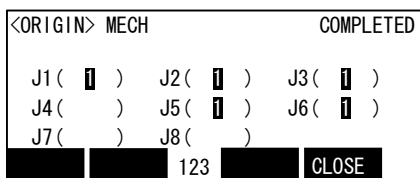
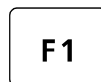

- 7) Setting of the origin is completed.

- 8) Refer to “5.5.3ABS origin method” on page 99 in this manual, and record the origin data on the origin data seal.

■ In the case of the 6-axis type

- 1) First, adjust the origin positions of the J4, J5 and J6 axes by referring to the paragraphs “(4)J4 axis origin setting(6-axis type only)(mechanical stopper)” on page 76, “(5)J5 axis origin setting(mechanical stopper)” on page 79 and “(6)J6 axis origin setting(mechanical stopper)” on page 81 above. Line up the ABS marks for the J6 axis and move the other axes into contact with the mechanical stoppers. At this point, the robot will have the posture shown below.

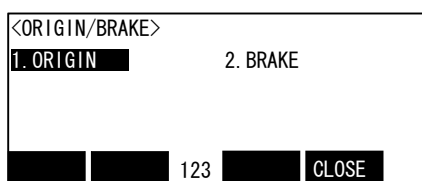
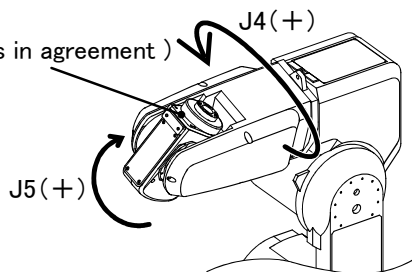

- 2) Press the [1] key, and display the Origin setting selection screen.

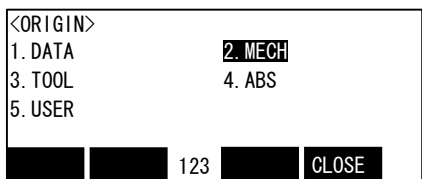
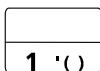

- 3) Press the [2] key, and display the Mechanical stopper selection screen.



- 4) Input “1” into the J4 to J6 axis. Set “0” to other axes.

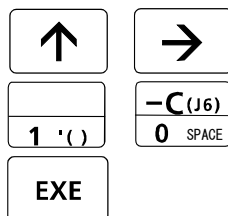

- 5) Press the [EXE] key, and display Confirmation screen..

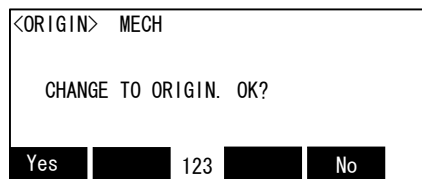

- 6) Press the [F1] key, and the origin position is set up.

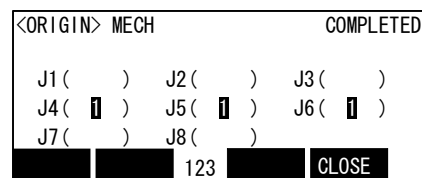
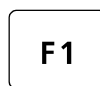

- 7) Setting of the origin of J4, J5 and J6 axis is completed.

- 8) Refer to “5.5.3ABS origin method” on page 99 in this manual, and record the origin data on the origin data seal.

- 9) Next, set the origins for the J1, J2 and J3 axes.

- 10) In order to avoid interference with the robot arm, return the J4 and J5 axes to the ABS mark positions. See “Fig. 5-12ABS mark attachment positions” on page 99 for the ABS mark positions.
 - 11) Move the J1, J2 and J3 axes into contact with the mechanical stoppers by referring to “(1)J1 axis origin setting(mechanical stopper)” on page 70, “(2)J2 axis origin setting(mechanical stopper)” on page 72 and “(3)J3 axis origin setting(mechanical stopper)” on page 74.
- At this point, the robot will have the posture shown below

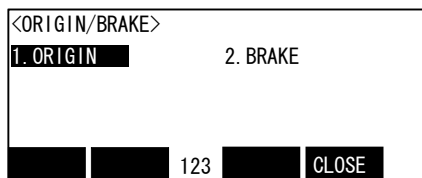
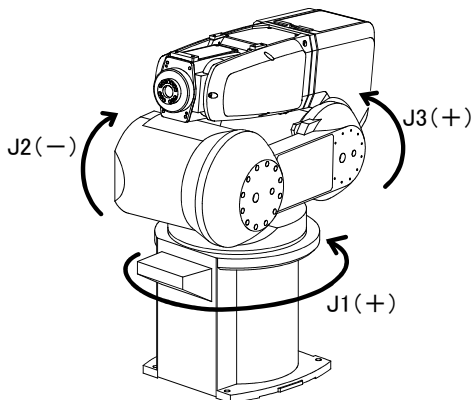

12) Press the [1] key , and display the Origin setting selection screen.

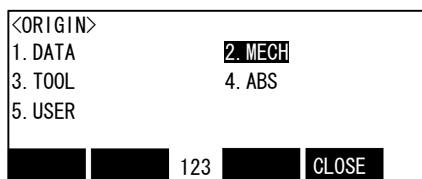
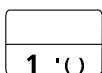

13) Press the [2] key , and display the Mechanical stopper selection screen.

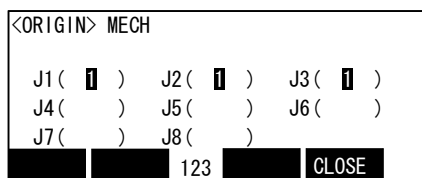
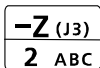

14) Input “1” into the J1 to J3 axis. Set “0” to other axes.

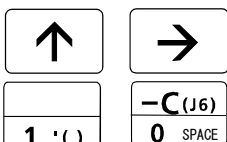

15) Press the [EXE] key , and display Confirmation screen.

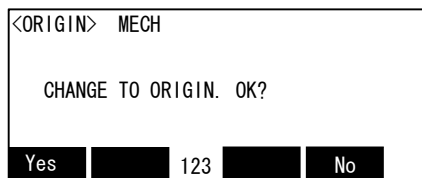

16) Press the [F1] key , and the origin position is set up.

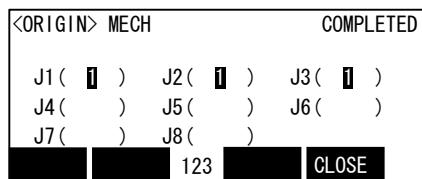
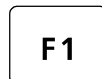

17) Setting of the origin of J1, J2 and J3 axis is completed.

18) Refer to “5.5.3ABS origin method” on page 99 in this manual, and record the origin data on the origin data seal.

5.5.2 Jig method

This method is using the origin setting tool. If the origin setting tool is required, please ask nearby dealer. The reference figure of the origin setting tool is shown in Fig. 5-11.

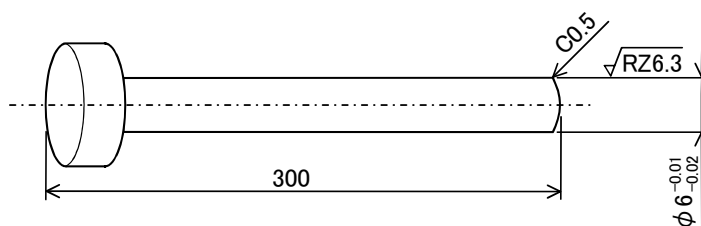

Fig.5-11 : Reference dimension of origin setting tool

The procedure of setting the origin with the origin setting tool is shown below.

Carry out this method for each axis.

First, set each axis by the origin position. There are the method of releasing the brake and adjusting with the origin position manually and the method of adjusting with the origin position by jog feed. Here, explain operation by brake release.

Then, do origin setting operation and set up the origin.



CAUTION

To ensure safety, the brake-release procedure described below should always be done by two persons.

This operation is carried out with the teaching pendant. Set the [MODE] switch on the front of the controller to "MANUAL", and set the [ENABLE] switch on the teaching pendant to "ENABLE" to enable the teaching pendant. Do the following operations, pressing down the enabling switch of T/B lightly.

(1) J1 axis origin setting

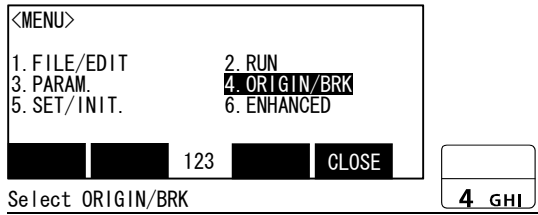

1) Press the [4] key on the menu screen, and display the Origin/Break selection screen.

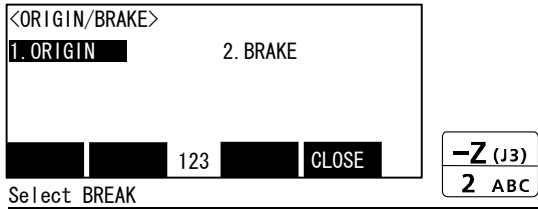

2) Press the [2] key, and display the Break release selection screen.

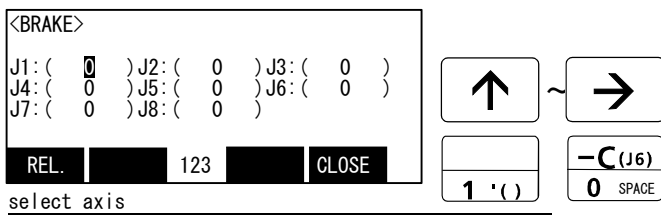

3) Release the brake of the J1 axis. Input "1" into the J1 axis. Set "0" to other axes.

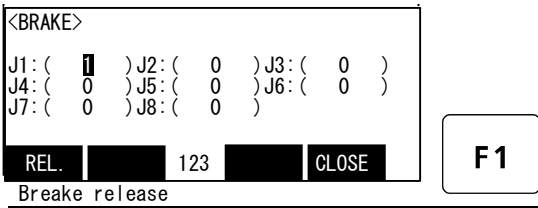

4) Confirm the axis for which the brakes are to be released.
5) Pressing the [F1] key is kept with the enabling switch of T/B pressed down. The brake is released while pressing the key.

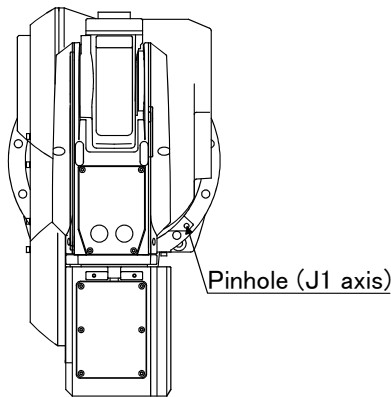
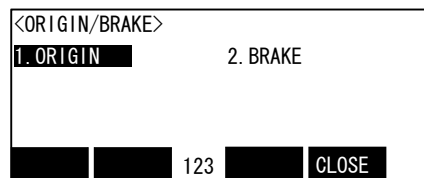

Diagram of the robot viewed from the top



7) Detach the [F1] key and work the brake. Press the [F4] key and return to the origin / brake screen.



8) Press the [1] key, and display the Origin setting selection screen.

<ORIGIN>	
1. DATA	2. MECH
3. TOOL	4. ABS
5. USER	
REL.	123
CLOSE	

Select TOOL

+Z (J3)
3 DEF

9) Press the [3] key , and display the Tool selection screen.

<TOOL>		
J1: (1)	J2: (0)	J3: (0)
J4: (0)	J5: (0)	J6: (0)
J7: (0)	J8: (0)	
REL.	123	CLOSE

↑	→
1 '()	-C (J6)
EXE	0 SPACE

10) Input "1" into the J1 axis. Set "0" to other axes.

11) Press the [EXE] key , and display Confirmation screen.

<ORIGIN> TOOL	
CHANGE TO ORIGIN. OK?	
Yes	No
REL.	123

F1

12) Press the [F1] key , and the origin position is set up.

<TOOL>		COMPLETED
J1: (1)	J2: (0)	J3: (0)
J4: (0)	J5: (0)	J6: (0)
J7: (0)	J8: (0)	
REL.	123	CLOSE

13) Setting of the origin is completed.

14) Refer to ["5.5.5Recording the origin data"](#) on page 103 in this manual, and record the origin data on the origin data seal.

◆◆◆ Release the brake ◆◆◆

Do cursor movement into the parenthesis of each axis by the arrow key. The brakes can be released only for the axis for which a "1" is displayed on the screen. If the brakes are not to be released, press the [0] key and display a "0". If the [F1] key on the teaching pendant or the enabling switch is detached while the brakes are released, the brakes will be work immediately.

◆◆◆ Select the axis of origin setting ◆◆◆

Do cursor movement into the parenthesis of each axis by the arrow key. The origin is set only for the axis for which a "1" is displayed on the screen. If the origin is not to be set, press the [0] key and display a "0".

(2) J2 axis origin setting

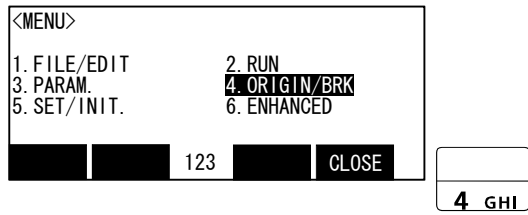

1) Press the [4] key on the menu screen, and display the Origin/Break selection screen.

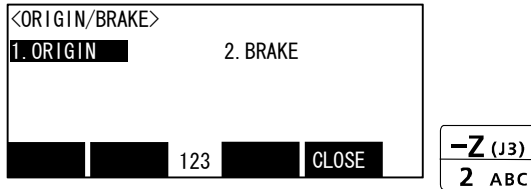

2) Press the [2] key, and display the Break release selection screen.

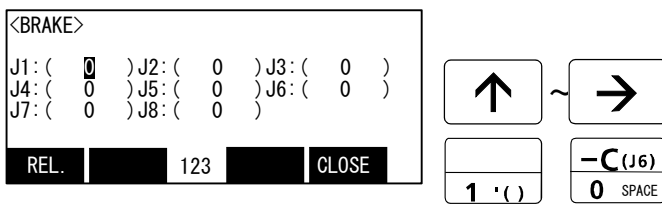

3) Release the brake of the J2 axis. Input "1" into the J2 axis. Set "0" to other axes.

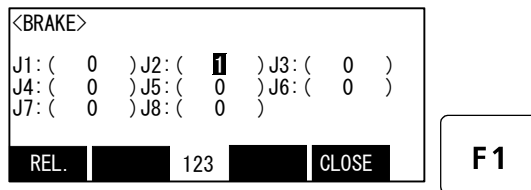

4) Confirm the axis for which the brakes are to be released.

5) One worker must securely support the upper arm with both hands.

6) Pressing the [F1] key is kept with the enabling switch of T/B pressed down. The brake is released while pressing the key.

7) Move the J2 axis slowly toward the front using both hands. Align the pinhole of the No.1 arm and the pinhole at the base section, feed through the origin jig (φ6) into the pinholes and fasten.

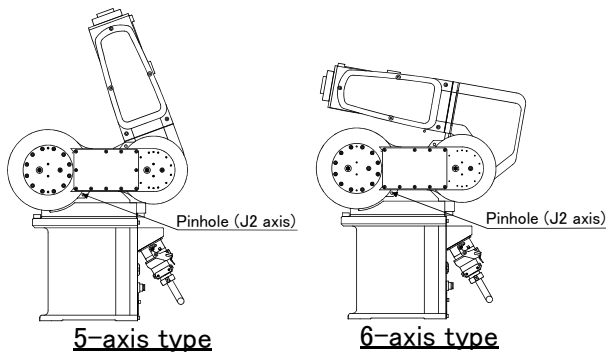

CAUTION

For safety purposes, the step for releasing the brakes must be carried out by two workers. One worker must operate the T/B, and the other must support the arm. When the brakes are released, the robot arm could drop by its own weight depending on the posture.

CAUTION

If [F1] key or enable switch of T/B is released, the brakes will be work immediately.

```

<BRAKE>
J1:( 0 ) J2:( 1 ) J3:( 0 )
J4:( 0 ) J5:( 0 ) J6:( 0 )
J7:( 0 ) J8:( 0 )
REL. 123 CLOSE

```

F4

- 8) Detach the [F1] key and work the brake.
Press the [F4] key and return to the origin / brake screen.

```

<ORIGIN/BRAKE>
1. ORIGIN 2. BRAKE
REL. 123 CLOSE

```

1 '()

- 9) Press the [1] key, and display the Origin setting selection screen.

```

<ORIGIN>
1. DATA 2. MECH
3. TOOL 4. ABS
5. USER
REL. 123 CLOSE

```

+Z (J3)
3 DEF

- 10) Press the [3] key, and display the Tool selection screen.

```

<TOOL>
J1:( 0 ) J2:( 1 ) J3:( 0 )
J4:( 0 ) J5:( 0 ) J6:( 0 )
J7:( 0 ) J8:( 0 )
REL. 123 CLOSE

```

↑

→

1 '()

-C (J6)
0 SPACE

EXE

- 11) Input "1" into the J2 axis. Set "0" to other axes.

- 12) Press the [EXE] key, and display Confirmation screen.

```

<ORIGIN> TOOL
CHANGE TO ORIGIN. OK?
Yes 123 No

```

F1

- 13) Press the [F1] key, and the origin position is set up.

```

<TOOL> COMPLETED
J1:( 0 ) J2:( 1 ) J3:( 0 )
J4:( 0 ) J5:( 0 ) J6:( 0 )
J7:( 0 ) J8:( 0 )
REL. 123 CLOSE

```

- 14) Setting of the origin is completed.

- 15) Refer to ["5.5.5 Recording the origin data"](#) on page 103 in this manual, and record the origin data on the origin data seal.

◆◆◆ Release the brake ◆◆◆

Do cursor movement into the parenthesis of each axis by the arrow key. The brakes can be released only for the axis for which a "1" is displayed on the screen. If the brakes are not to be released, press the [0] key and display a "0". If the [F1] key on the teaching pendant or the enabling switch is detached while the brakes are released, the brakes will be work immediately.

◆◆◆ Select the axis of origin setting ◆◆◆

Do cursor movement into the parenthesis of each axis by the arrow key. The origin is set only for the axis for which a "1" is displayed on the screen. If the origin is not to be set, press the [0] key and display a "0".

(3) J3 axis origin setting

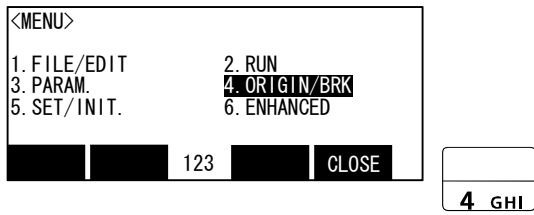

1) Press the [4] key on the menu screen, and display the Origin/Break selection screen.

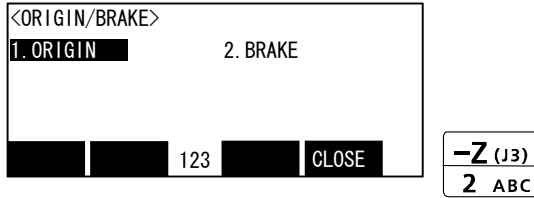

2) Press the [2] key, and display the Break release selection screen.

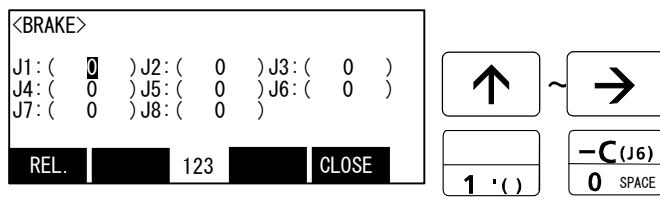

3) Release the brake of the J3 axis. Input "1" into the J3 axis. Set "0" to other axes.

4) Confirm the axis for which the brakes are to be released.

5) One worker must securely support the upper arm with both hands.

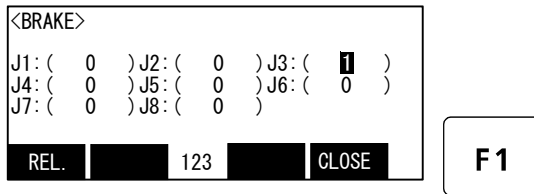

6) Pressing the [F1] key is kept with the enabling switch of T/B pressed down. The brake is released while pressing the key.

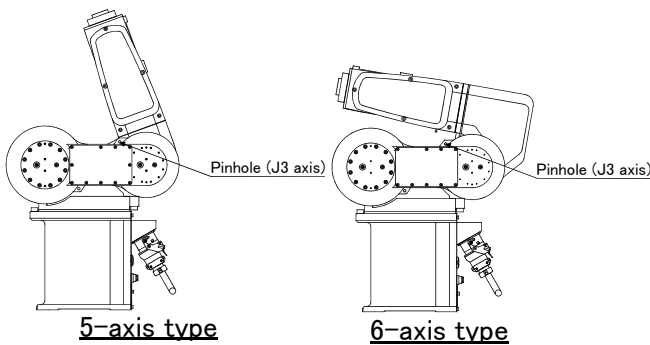

7) Move the J3 axis slowly toward the front using both hands. Align the pinhole of the No.1 arm and the pinhole at the base section, feed through the origin jig ($\phi 6$) into the pinholes and fasten.

CAUTION For safety purposes, the step for releasing the brakes must be carried out by two workers. One worker must operate the T/B, and the other must support the arm. When the brakes are released, the robot arm could drop by its own weight depending on the posture.

CAUTION If [F1] key or enable switch of T/B is released, the brakes will be work immediately.

```

<BRAKE>
J1:( 0 )J2:( 0 )J3:( 1 )
J4:( 0 )J5:( 0 )J6:( 0 )
J7:( 0 )J8:( 0 )
REL. 123 CLOSE

```

F4

- 8) Detach the [F1] key and work the brake.
Press the [F4] key and return to the origin / brake screen.

```

<ORIGIN/BRAKE>
1. ORIGIN 2. BRAKE
REL. 123 CLOSE

```

1 '()

- 9) Press the [1] key, and display the Origin setting selection screen.

```

<ORIGIN>
1. DATA 2. MECH
3. TOOL 4. ABS
5. USER
REL. 123 CLOSE

```

+Z (J3)
3 DEF

- 10) Press the [3] key, and display the Tool selection screen.

```

<TOOL>
J1:( 0 )J2:( 0 )J3:( 1 )
J4:( 0 )J5:( 0 )J6:( 0 )
J7:( 0 )J8:( 0 )
REL. 123 CLOSE

```

-C (J6)
0 SPACE

1 '()

EXE

- 11) Input "1" into the J3 axis. Set "0" to other axes.
12) Press the [EXE] key, and display Confirmation screen.

```

<ORIGIN> TOOL
CHANGE TO ORIGIN. OK?
Yes 123 No

```

F1

- 13) Press the [F1] key, and the origin position is set up.

```

<TOOL> COMPLETED
J1:( 0 )J2:( 0 )J3:( 1 )
J4:( 0 )J5:( 0 )J6:( 0 )
J7:( 0 )J8:( 0 )
REL. 123 CLOSE

```

- 14) Setting of the origin is completed.

- 15) Refer to "5.5.5 Recording the origin data" on page 103 in this manual, and record the origin data on the origin data seal.

◆◆◆ Release the brake ◆◆◆

Do cursor movement into the parenthesis of each axis by the arrow key. The brakes can be released only for the axis for which a "1" is displayed on the screen. If the brakes are not to be released, press the [0] key and display a "0". If the [F1] key on the teaching pendant or the enabling switch is detached while the brakes are released, the brakes will be work immediately.

◆◆◆ Select the axis of origin setting ◆◆◆

Do cursor movement into the parenthesis of each axis by the arrow key. The origin is set only for the axis for which a "1" is displayed on the screen. If the origin is not to be set, press the [0] key and display a "0".

(4) J4 axis origin setting (6-axis type only)

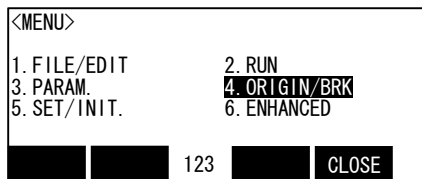

1) Press the [4] key on the menu screen, and display the Origin/Break selection screen.

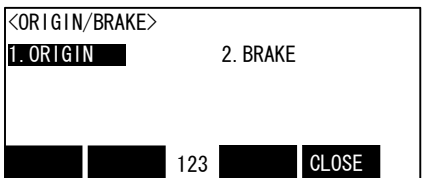

2) The type which does not have the brake in the J4 axis should go to "7)"->"9)". Press the [2] key, and display the Break release selection screen.

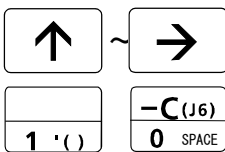
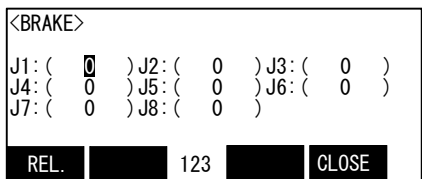

3) Release the brake of the J4 axis. Input "1" into the J4 axis. Set "0" to other axes.

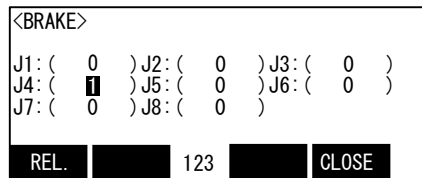

4) Confirm the axis for which the brakes are to be released.
 5) One worker must securely support the upper arm with both hands.
 6) Pressing the [F1] key is kept with the enabling switch of T/B pressed down. The brake is released while pressing the key.

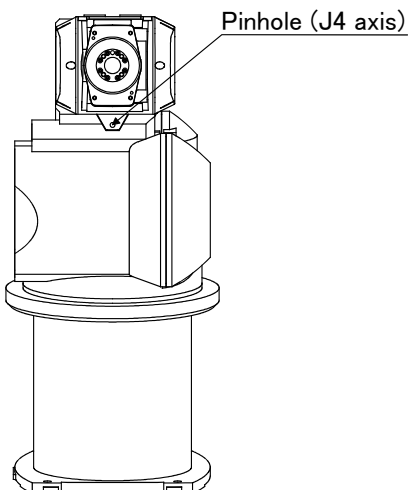

7) Slowly rotate the J4 axis in the direction of minus with both hands. Align the pinholes of the No. 1 arm and shoulder, feed through the origin jig ($\phi 6$) into the pinholes and fasten.

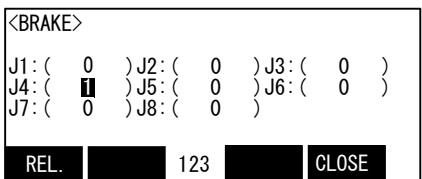

8) Detach the [F1] key and work the brake. Press the [F4] key and return to the origin / brake screen.

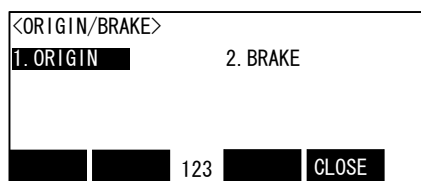

9) Press the [1] key , and display the Origin setting selection screen.

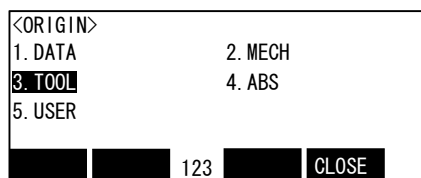

10) Press the [3] key , and display the Tool selection screen.

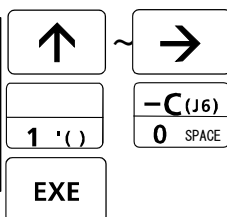
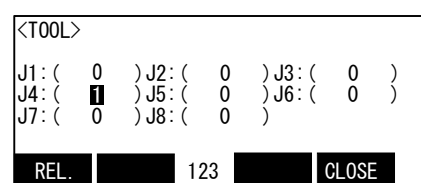
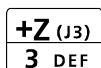

11) Input "1" into the J4 axis. Set "0" to other axes.

12) Press the [EXE] key , and display Confirmation screen.

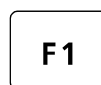
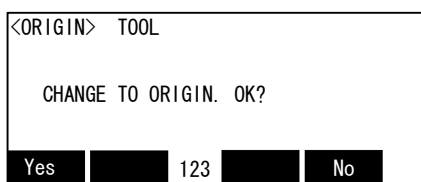

13) Press the [F1] key , and the origin position is set up.

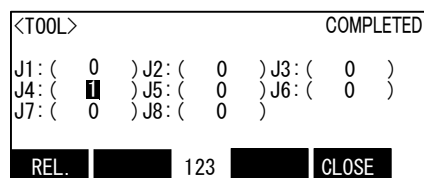

14) Setting of the origin is completed.

15) Refer to ["5.5.5Recording the origin data"](#) on [page 103](#) in this manual, and record the origin data on the origin data seal.

◆◆◆ Release the brake ◆◆◆

Do cursor movement into the parenthesis of each axis by the arrow key. The brakes can be released only for the axis for which a "1" is displayed on the screen. If the brakes are not to be released, press the [0] key and display a "0". If the [F1] key on the teaching pendant or the enabling switch is detached while the brakes are released, the brakes will be work immediately.

◆◆◆ Select the axis of origin setting ◆◆◆

Do cursor movement into the parenthesis of each axis by the arrow key. The origin is set only for the axis for which a "1" is displayed on the screen. If the origin is not to be set, press the [0] key and display a "0".

(5) J5 axis origin setting

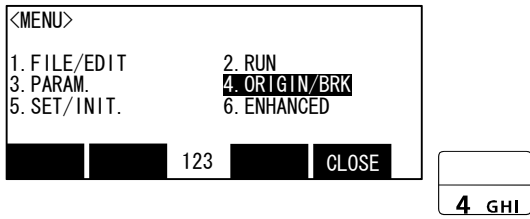

- 1) Remove the No. 2 arm cover A (on the left side facing the front of the robot). There is a pin hole in the cover.
- 2) Press the [4] key on the menu screen, and display the Origin/Break selection screen.

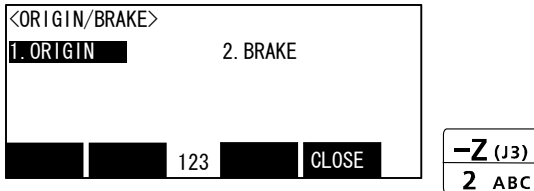

- 3) Press the [2] key, and display the Break release selection screen.

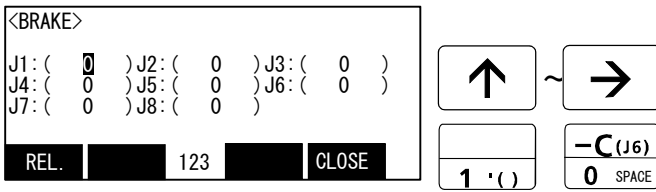

- 4) Release the brake of the J5 axis. Input "1" into the J5 axis. Set "0" to other axes.

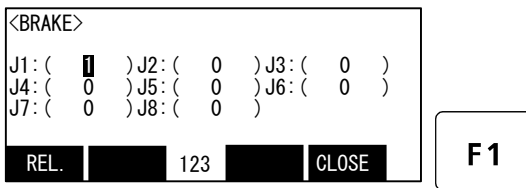

- 5) Confirm the axis for which the brakes are to be released.
- 6) One worker must securely support the upper arm with both hands.
- 7) Pressing the [F1] key is kept with the enabling switch of T/B pressed down. The brake is released while pressing the key.

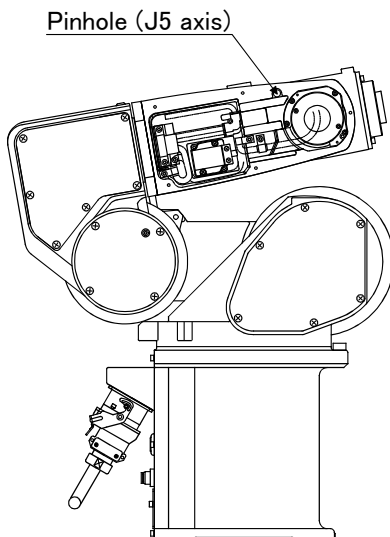

- 8) Slowly rotate the J5 axis in the direction of plus 90° with both hands. Align the pinholes of the No. 2 arm and wrist housing, feed through the origin jig (φ6) into the pinholes and fasten.

CAUTION

For safety purposes, the step for releasing the brakes must be carried out by two workers. One worker must operate the T/B, and the other must support the arm. When the brakes are released, the robot arm could drop by its own weight depending on the posture.

CAUTION If [F1] key or enable switch of T/B is released, the brakes will be work immediately.

```
<BRAKE>
J1: ( 1 ) J2: ( 0 ) J3: ( 0 )
J4: ( 0 ) J5: ( 0 ) J6: ( 0 )
J7: ( 0 ) J8: ( 0 )
REL. 123 CLOSE
```

F4

- 9) Detach the [F1] key and work the brake.
Press the [F4] key and return to the origin / brake screen.

```
<ORIGIN/BRAKE>
1. ORIGIN 2. BRAKE
123 CLOSE
```

1 '()

- 10) Press the [1] key , and display the Origin setting selection screen.

```
<ORIGIN>
1. DATA 2. MECH
3. TOOL 4. ABS
5. USER
123 CLOSE
```

+Z (J3)
3 DEF

- 11) Press the [3] key , and display the Tool selection screen.

```
<TOOL>
J1: ( 1 ) J2: ( 0 ) J3: ( 0 )
J4: ( 0 ) J5: ( 0 ) J6: ( 0 )
J7: ( 0 ) J8: ( 0 )
REL. 123 CLOSE
```

↑

→

1 '()

-C (J6)
0 SPACE

EXE

- 12) Input "1" into the J5 axis. Set "0" to other axes.
13) Press the [EXE] key , and display Confirmation screen.

```
<ORIGIN> TOOL
CHANGE TO ORIGIN. OK?
Yes 123 No
```

F1

- 14) Press the [F1] key , and the origin position is set up.

```
<TOOL>
J1: ( 1 ) J2: ( 0 ) J3: ( 0 )
J4: ( 0 ) J5: ( 0 ) J6: ( 0 )
J7: ( 0 ) J8: ( 0 )
REL. 123 CLOSE
```

- 15) Setting of the origin is completed.

- 16) Refer to "5.5.3ABS origin method" on page 99 in this manual, and record the origin data on the origin data seal.
Replace the cover.

◆◆◆ Release the brake ◆◆◆

Do cursor movement into the parenthesis of each axis by the arrow key. The brakes can be released only for the axis for which a "1" is displayed on the screen. If the brakes are not to be released, press the [0] key and display a "0". If the [F1] key on the teaching pendant or the enabling switch is detached while the brakes are released, the brakes will be work immediately.

◆◆◆ Select the axis of origin setting ◆◆◆

Do cursor movement into the parenthesis of each axis by the arrow key. The origin is set only for the axis for which a "1" is displayed on the screen. If the origin is not to be set, press the [0] key and display a "0".

(6) J6 axis origin setting

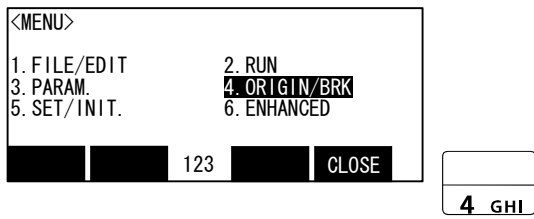

- 1) Install the bolts (two M5 bolts prepared by customer) at opposing positions on the mechanical interface.
- 2) Press the [4] key on the menu screen, and display the Origin/Break selection screen.

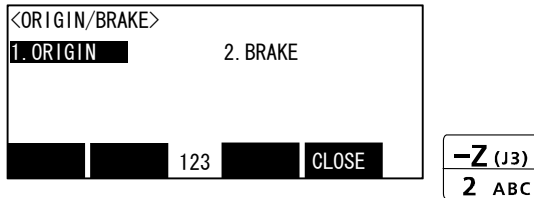

- 3) Press the [2] key, and display the Break release selection screen.

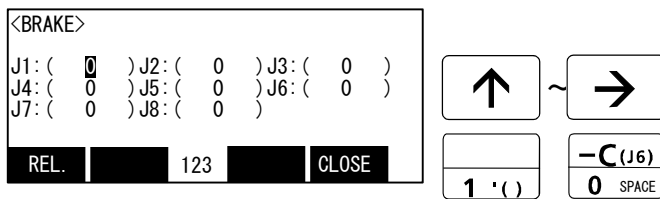

- 4) Release the brake of the J6 axis. Input "1" into the J6 axis. Set "0" to other axes.

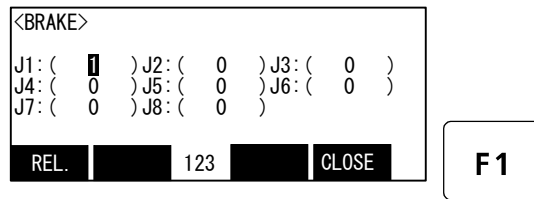

- 5) Confirm the axis for which the brakes are to be released.
- 6) Pressing the [F1] key is kept with the enabling switch of T/B pressed down. The brake is released while pressing the key.

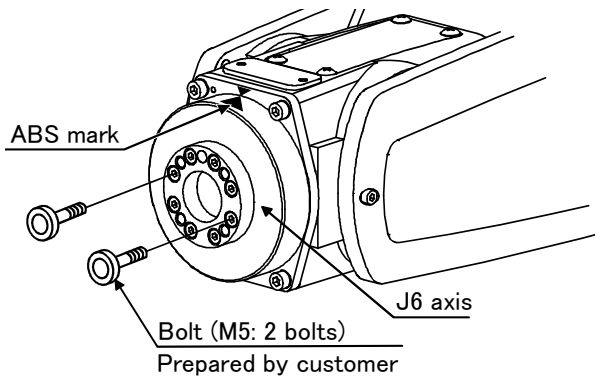

- 7) Hold the bolts mounted in step "1" above with hands, rotate them slowly and align the ABS mark of the J6 axis with the ABS mark of the wrist area.

CAUTION The J6-axis dose not have a mechanical stopper. When setting the origin position, do not rotate the axis more than themotion range(± 200 deg.).

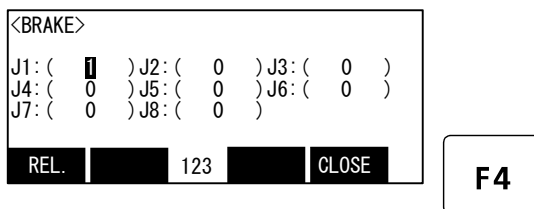

- 8) Detach the [F1] key and work the brake. Press the [F4] key and return to the origin / brake screen.

<ORIGIN/BRAKE>		
1. ORIGIN	2. BRAKE	
REL.	123	CLOSE

9) Press the [1] key , and display the Origin setting selection screen.

<ORIGIN>		
1. DATA	2. MECH	
3. TOOL	4. ABS	
5. USER		
REL.	123	CLOSE

10) Press the [3] key , and display the Tool selection screen.

+Z (J3)
3 DEF

<TOOL>		
J1: (1)	J2: (0)	J3: (0)
J4: (0)	J5: (0)	J6: (0)
J7: (0)	J8: (0)	
REL.	123	CLOSE

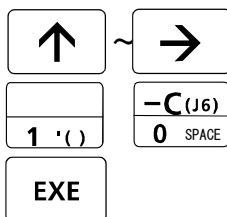

11) Input "1" into the J6 axis. Set "0" to other axes.

12) Press the [EXE] key , and display Confirmation screen.

<ORIGIN> TOOL		
CHANGE TO ORIGIN. OK?		
Yes	123	No

F1

13) Press the [F1] key , and the origin position is set up.

<TOOL>		
J1: (1)	J2: (0)	J3: (0)
J4: (0)	J5: (0)	J6: (0)
J7: (0)	J8: (0)	
REL.	123	CLOSE

14) Setting of the origin is completed.

15) Refer to "[5.5.3ABS origin method](#)" on page 99 in this manual, and record the origin data on the origin data seal.

◆◆◆ Release the brake ◆◆◆

Do cursor movement into the parenthesis of each axis by the arrow key. The brakes can be released only for the axis for which a "1" is displayed on the screen. If the brakes are not to be released, press the [0] key and display a "0". If the [F1] key on the teaching pendant or the enabling switch is detached while the brakes are released, the brakes will be work immediately.

◆◆◆ Select the axis of origin setting ◆◆◆

Do cursor movement into the parenthesis of each axis by the arrow key. The origin is set only for the axis for which a "1" is displayed on the screen. If the origin is not to be set, press the [0] key and display a "0".

5.5.3 ABS origin method

When the origin setting of the robot is performed for the first time, this product records the angular position of the origin within one rotation of the encoder as the offset value. If the origin setting is performed according to the ABS origin method, this value is used to suppress variations in the origin setting operations and to reproduce the initial origin position accurately.

This operation is carried out with the teaching pendant. Set the [MODE] switch on the front of the controller to "MANUAL", and set the [ENABLE] switch on the teaching pendant to "ENABLE" to enable the teaching pendant. First, set to the ABS mark arrow of the axis for which the origin is to be set with jog operation. This can be set for all axes simultaneously or each axis independently.

When setting the ABS mark, always view the operations from the mark, and set at the end of the triangular mark. The positions where the ABS mark is attached are shown in below. Refer to "1.5 Confirming the operation" on page 40 for details on the jog operation.

Note that if the ABS marks are peeled off, the positions can be matched using the following alternative methods.

- (1) J1 to J5 axis ^{Note)}Match the pin holes described in "5.5.2 Jig method" on page 86 above.
- (2) J5 axis ^{Note)} , J6 axisMatch the ruling lines of the ABS mark mounting position surfaces.

Note) Both methods (1) and (2) above can be used for the J5 axis. To carry out by (2), the installing and removing of the cover are unnecessary.

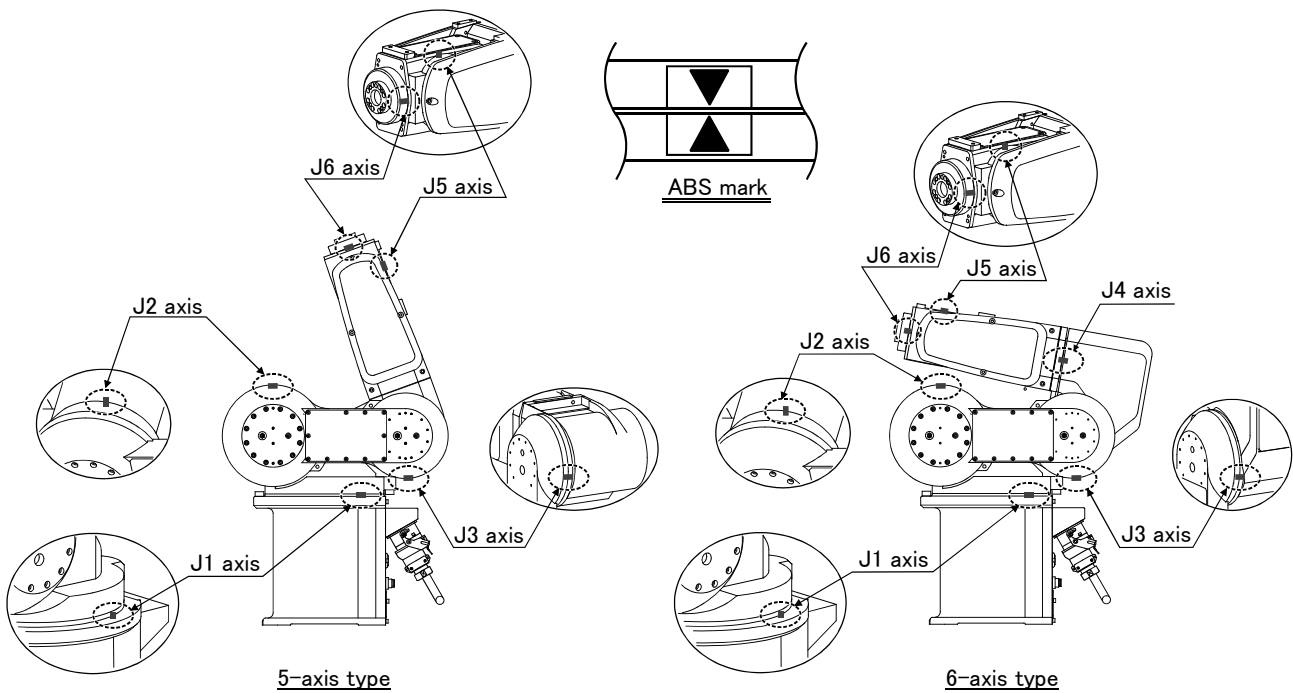

Fig.5-12 : ABS mark attachment positions

The procedures for setting the origin with the ABS method are explained below.

(1) Select the T/B

```

<MENU>
1. FILE/EDIT      2. RUN
3. PARAM.        4. ORIGIN/BRK
5. SET/INIT.     6. ENHANCED
REL. 123 CLOSE
  
```

```

  4 GHI
  
```

1) Press the [4] key on the menu screen, and display the Origin/Break selection screen.

```

<ORIGIN/BRAKE>
1. ORIGIN      2. BRAKE
REL. 123 CLOSE
  
```

```

  1 '()
  
```

2) Press the [1] key, and display the Origin setting selection screen.

```

<ORIGIN>
1. DATA      2. MECH
3. TOOL      4. ABS
5. USER
REL. 123 CLOSE
  
```

```

  4 GHI
  
```

3) Press the [4] key, and display the ABSI selection screen.

```

<ABS>
J1:( 1 ) J2:( 0 ) J3:( 0 )
J4:( 0 ) J5:( 0 ) J6:( 0 )
J7:( 0 ) J8:( 0 )
REL. 123 CLOSE
  
```

```

  ↑ ~ →
  1 '() → EXE
  
```

4) Input "1" into the axis to origin setting. Press the [EXE] key, and display Confirmation screen.

```

<ORIGIN> ABS
CHANGE TO ORIGIN. OK?
Yes 123 No
  
```

```

  F1
  
```

5) Press the [F1] key, and the origin position is set up.

```

<ABS>
J1:( 1 ) J2:( 0 ) J3:( 0 )
J4:( 0 ) J5:( 0 ) J6:( 0 )
J7:( 0 ) J8:( 0 )
REL. 123 CLOSE
  
```

This completes the setting of the origin with the ABS method.

5.5.4 User origin method



CAUTION

Before using this method, the origin must be set with the other method. The setting method is explained in "Table 5-8 : Origin setting method" on page 69.

The procedure for setting the origin with the user origin method is explained below. This operation is carried out with the teaching pendant. Set the [MODE] switch on the front of the controller to "AMNUAL", and set the [ENABLE] switch on the teaching pendant to "ENABLE" to enable the teaching pendant. The operation method is shown below.

When setting the origin for the first time using this method, carry out the operations in order from step 1). For the second and following time, move the robot arm to the user origin position with jog operation, and accurately position all axes. Then start the procedure from step 4).

- 1) Determine the user origin position
Move the robot to the position to be set as the origin with jog operation. Refer to "2.5 Confirming the operation" on page 25 for details on the jog operation.



CAUTION

Choose the user origin position as the position where it doesn't move by the gravity. This position is left as a guideline to position all axes with jog operation when setting the origin again with this method.

- 2) Enter the JOINT jog mode, and display the joint coordinates on the teaching pendant screen. Record the value of the axis for which the origin is to be set.
- 3) Input the value recorded in the "user designated origin parameter (USRORG)".
The parameter details and input methods are described in the separate "Instruction Manual/Detailed Explanation of Functions and Operations". Refer to that manual and input the user designated origin position.

<MENU>	
1. FILE/EDIT	2. RUN
3. PARAM.	4. ORIGIN/BRK
5. SET/INIT.	6. ENHANCED
123	CLOSE

4 GHI

- 4) Next, set the origin.
Display the menu screen.

- 5) Press the [4] key on the menu screen, and display the Origin/Break selection screen.

<ORIGIN/BRAKE>	
1. ORIGIN	2. BRAKE
123	CLOSE

1 '()

- 6) Press the [1] key, and display the Origin setting selection screen.

<ORIGIN>	
1. DATA	2. MECH
3. TOOL	4. ABS
5. USER	
123	CLOSE

-A (J4)
5 JKL

- 7) Press the [5] key, and display the User selection screen.

```
<USER>
J1:( 1 )J2:( 0 )J3:( 0 )
J4:( 0 )J5:( 0 )J6:( 0 )
J7:( 0 )J8:( 0 )
REL. 123 CLOSE
```

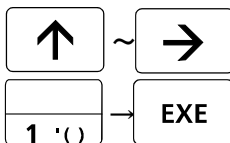

8) Input "1" into the axis to origin setting. Press the [EXE] key, and display Confirmation screen.

```
<ORIGIN> USER
CHANGE TO ORIGIN. OK?
Yes 123 No
```



9) Press the [F1] key, and the origin position is set up.

This completes the setting of the origin with the user origin method.

5.5.5 Recording the origin data

When the origin has been set with the jig method, record that origin data on the origin data label. With this, the origin can be set with the origin data input method the next time.

Confirm the origin data on the teaching pendant screen (origin data input screen). The origin data label is enclosed with the arm or attached on the back of the shoulder cover A.

The teaching pendant operation method and shoulder cover A removal method for confirming the origin data is the same as the methods for setting the origin with the origin data input method. Refer to [“2.3.2Setting the origin with the origin data input method” on page 12](#), and write the origin data displayed on the teaching pendant onto the origin label.

(1) Confirming the origin data label

Remove the shoulder cover A.

Refer to [“5.3.2Installing/removing the cover” on page 58](#), and remove the shoulder cover A.

(2) Confirming the origin data

Confirm the value displayed on the teaching pendant’s Origin Data Input screen.

Refer to [“2.3.2Setting the origin with the origin data input method”“\(5\)Inputting the origin data”](#), and display the Origin Data Input screen on the teaching pendant display screen.

(3) Recording the origin data

Write the origin data displayed on the teaching pendant to the origin data label attached to the back of the shoulder cover A. Refer to [“Fig. 2-8Origin data label \(an example\)” on page 12](#), and [“Fig. 2-9Correspondence of origin data label and axis” on page 15](#) for details on the origin data label.

(4) Installing the cover

Install the shoulder cover A removed in step [“\(1\)Confirming the origin data label”](#) above.

Refer to [“5.3.2Installing/removing the cover” on page 58](#), and replace the shoulder cover A.

This completes the recording of the origin data.

6 Appendix

Appendix 1 : Configuration flag

The configuration flag indicates the robot posture.

For the 6-axis type robot, the robot hand end is saved with the position data configured of X, Y, Z, A, B and C. However, even with the same position data, there are several postures that the robot can change to. The posture is expressed by this configuration flag, and the posture is saved with FL1 in the position constant (X, Y, Z, A, B, C) (FL1, FL2).

The types of configuration flags are shown below.

(1) RIGHT/LEFT

P is center of flange in comparison with the plane through the J1 axis vertical to the ground.

Q is center of J5 axis rotation in comparison with the plane through the J1 axis vertical to the ground.

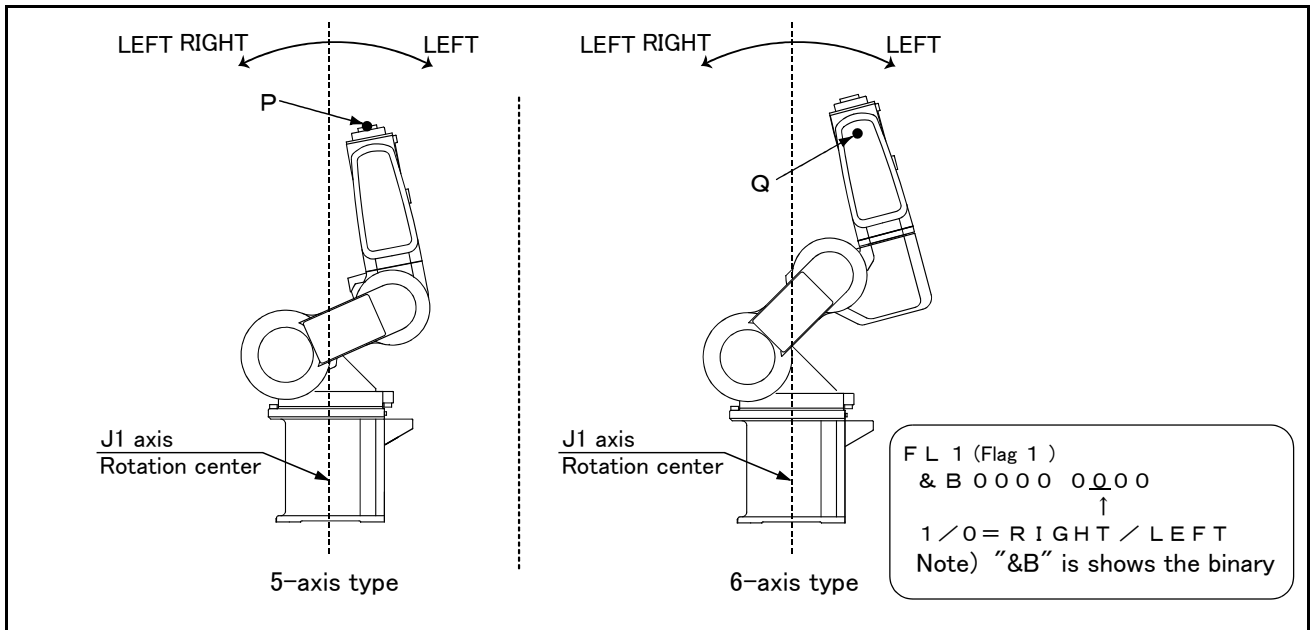

Fig.6-1 : Configuration flag (RIGHT/LEFT)

(2) ABOVE/BELOW

Q is center of J5 axis rotation in comparison with the plane through both the J3 and the J2 axis.

(3) NONFLIP/FLIP (6-axis robot only.)

This means in which side the J6 axis is in comparison with the plane through both the J4 and the J5 axis.

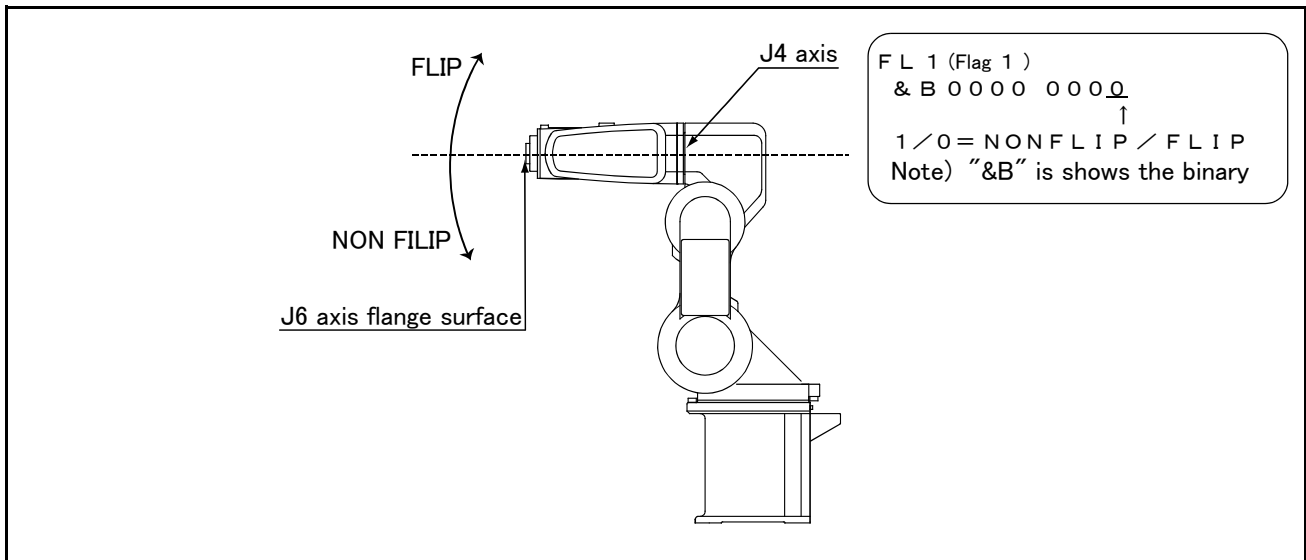

Fig.6-3 : Configuration flag (NONFLIP/FLIP)



HEAD OFFICE: TOKYO BUILDING, 2-7-3, MARUNOUCHI, CHIYODA-KU, TOKYO 100-8310, JAPAN
NAGOYA WORKS: 5-1-14, YADA-MINAMI, HIGASHI-KU, NAGOYA 461-8670, JAPAN

Authorised representative:

MITSUBISHI ELECTRIC EUROPE B.V. GERMANY

Gothaer Str. 8, 40880 Ratingen / P.O. Box 1548, 40835 Ratingen, Germany

HEADQUARTERS

MITSUBISHI ELECTRIC EUROPE B.V. **EUROPE**
 German Branch
 Gothaer Straße 8
D-40880 Ratingen
 Phone: +49 (0)2102 / 486-0
 Fax: +49 (0)2102 / 486-1120

MITSUBISHI ELECTRIC EUROPE B.V. **CZECH REPUBLIC**
 Czech Branch
 Avenir Business Park, Radlická 714/113a
CZ-158 00 Praha 5
 Phone: +420 - 251 551 470
 Fax: +420 (0)251-551-471

MITSUBISHI ELECTRIC EUROPE B.V. **FRANCE**
 French Branch
 25, Boulevard des Bouvets
F-92741 Nanterre Cedex
 Phone: +33 (0)1 / 55 68 55 68
 Fax: +33 (0)1 / 55 68 57 57

MITSUBISHI ELECTRIC EUROPE B.V. **IRELAND**
 Irish Branch
 Westgate Business Park, Ballymount
IRL-Dublin 24
 Phone: +353 (0)1 4198800
 Fax: +353 (0)1 4198890

MITSUBISHI ELECTRIC EUROPE B.V. **ITALY**
 Italian Branch
 Viale Colleoni 7
I-20041 Agrate Brianza (MB)
 Phone: +39 039 / 60 53 1
 Fax: +39 039 / 60 53 312

MITSUBISHI ELECTRIC EUROPE B.V. **POLAND**
 Poland Branch
 Krakowska 50
PL-32-083 Balice
 Phone: +48 (0)12 / 630 47 00
 Fax: +48 (0)12 / 630 47 01

MITSUBISHI ELECTRIC EUROPE B.V. **SPAIN**
 Spanish Branch
 Carretera de Rubí 76-80
E-08190 Sant Cugat del Vallés (Barcelona)
 Phone: 902 131121 // +34 935653131
 Fax: +34 935891579

MITSUBISHI ELECTRIC EUROPE B.V. **UK**
 UK Branch
 Travellers Lane
UK-Hatfield, Herts. AL10 8XB
 Phone: +44 (0)1707 / 27 61 00
 Fax: +44 (0)1707 / 27 86 95

MITSUBISHI ELECTRIC CORPORATION **JAPAN**
 Office Tower "Z" 14 F
 8-12, 1 chome, Harumi Chuo-Ku
Tokyo 104-6212
 Phone: +81 3 622 160 60
 Fax: +81 3 622 160 75

MITSUBISHI ELECTRIC AUTOMATION, Inc. **USA**
 500 Corporate Woods Parkway
Vernon Hills, IL 60061
 Phone: +1 847 478 21 00
 Fax: +1 847 478 22 53

EUROPEAN REPRESENTATIVES

GEVA **AUSTRIA**
 Wiener Straße 89
AT-2500 Baden
 Phone: +43 (0)2252 / 85 55 20
 Fax: +43 (0)2252 / 488 60

Koning & Hartman b.v. **BELGIUM**
 Woluwelaan 31
BE-1800 Vilvoorde
 Phone: +32 (0)2 / 257 02 40
 Fax: +32 (0)2 / 257 02 49

INEA BH d.o.o. **BOSNIA AND HERZEGOVINA**
 Aleja Lipa 56
BA-71000 Sarajevo
 Phone: +387 (0)33 / 921 164
 Fax: +387 (0)33 / 524 539

AKHNATON **BULGARIA**
 4 Andrej Ljapchev Blvd. Pb 21
BG-1756 Sofia
 Phone: +359 (0)2 / 817 6004
 Fax: +359 (0)2 / 97 44 06 1

AutoCont C.S. s.r.o. **CZECH REPUBLIC**
 Technologická 374/6
CZ-708 00 Ostrava-Pustkovec
 Phone: +420 595 691 150
 Fax: +420 595 691 199

B:ELECTRIC, s.r.o. **CZECH REPUBLIC**
 Mladoboleslavská 812
CZ-197 00 Praha 19 - Kbely
 Phone: +420 286 850 848, +420 724 317 975
 Fax: +420 286 850 850

Beijer Electronics A/S **DENMARK**
 Lykkegårdsvej 17, 1.
DK-4000 Roskilde
 Phone: +45 (0)46 / 75 76 66
 Fax: +45 (0)46 / 75 56 26

Beijer Electronics OY **FINLAND**
 Jaakonkatu 2
FIN-01620 Vantaa
 Phone: +358 (0)207 / 463 500
 Fax: +358 (0)207 / 463 501

UTECO A.B.E.E. **GREECE**
 5, Mavrogenous Str.
GR-18542 Piraeus
 Phone: +30 211 / 1206 900
 Fax: +30 211 / 1206 999

AXICONT AUTOMATIKA KFT. **HUNGARY**
 (ROBOT CENTER) Reitter F. U. 132
HU-1131 Budapest
 Phone: +36 1 / 412-0882
 Fax: +36 1 / 412-0883

ALFATRADE Ltd. **MALTA**
 99, Paola Hill
Malta- Paola PLA 1702
 Phone: +356 (0)21 / 697 816
 Fax: +356 (0)21 / 697 817

HIFLEX AUTOM. TECHNIK B.V. **NETHERLANDS**
 Woluweverstraat 22
NL-2984 CD Ridderkerk
 Phone: +31 (0)180 - 46 60 04
 Fax: +31 (0)180 - 44 23 55

EUROPEAN REPRESENTATIVES

Koning & Hartman b.v. **NETHERLANDS**
 Haarlerbergweg 21-23
NL-1101 CH Amsterdam
 Phone: +31 (0)20 / 587 76 00
 Fax: +31 (0)20 / 587 76 05

Beijer Electronics AS **NORWAY**
 Postboks 487
NO-3002 Drammen
 Phone: +47 (0)32 / 24 30 00
 Fax: +47 (0)32 / 84 85 77

SIRIUS TRADING & SERVICES SRL **ROMANIA**
 Aleea Lacul Morii Nr. 3
RO-060841 Bucuresti, Sector 6
 Phone: +40 (0)21 / 430 40 06
 Fax: +40 (0)21 / 430 40 02

INEA SR d.o.o. **SERBIA**
 Izletnicka 10
SER-113000 Smederevo
 Phone: +381 (0)26 / 617 163
 Fax: +381 (0)26 / 617 163

CS MTrade Slovensko, s.r.o **SLOVAKIA**
 Vajanskeho 58
SK-92101 Piestany
 Phone: +421 (0)33 / 7742 760
 Fax: +421 (0)33 / 7735 144

INEA d.o.o. **SLOVENIA**
 Stegne 11
SI-1000 Ljubljana
 Phone: +386 (0)1 / 513 8100
 Fax: +386 (0)1 / 513 8170

Beijer Electronics Automation AB **SWEDEN**
 Box 426
SE-20124 Malmö
 Phone: +46 (0)40 / 35 86 00
 Fax: +46 (0)40 / 35 86 02

Robotronic AG **SWITZERLAND**
 Schlachthofstrasse 8
CH-8406 Winterthur
 Phone: +41 (0)52 / 203 35 65
 Fax: +41 (0)52 / 203 35 66

GTS **TURKEY**
 Bayraktar Bulvari Nutuk Sok. No:5
TR-34775 Yukarı Dudullu-Ümraniye-İSTANBUL
 Phone: +90 (0)216 526 39 90
 Fax: +90 (0)216 526 39 95

CSC Automation Ltd. **UKRAINE**
 4-B, M. Raskovoyi St.
UA-02660 Kiev
 Phone: +380 (0)44 / 494 33 55
 Fax: +380 (0)44 / 494-33-66

MIDDLE EAST REPRESENTATIVE

ILAN & GAVISH Ltd. **ISRAEL**
 24 Shenkar St., Kiryat Arie
IL-49001 Petaht-Tiqva
 Phone: +972 (0)3 / 922 18 24
 Fax: +972 (0)3 / 924 0761

AFRICAN REPRESENTATIVE

CBI Ltd. **SOUTH AFRICA**
 Private Bag 2016
ZA-1600 Isando
 Phone: + 27 (0)11 / 977 0770
 Fax: + 27 (0)11 / 977 0761