

mitsubishi

Mitsubishi Industrial Robot







SQ Series

RV-6SQ/6SQL Series

Special Specifications Manual
(CR2QA-700 series/CR3Q-711M Controller)

Safety Precautions

Always read the following precautions and the separate "Safety Manual" before starting use of the robot to learn the required measures to be taken.

-  **CAUTION** All teaching work must be carried out by an operator who has received special training. (This also applies to maintenance work with the power source turned ON.)
Enforcement of safety training
-  **CAUTION** For teaching work, prepare a work plan related to the methods and procedures of operating the robot, and to the measures to be taken when an error occurs or when restarting. Carry out work following this plan. (This also applies to maintenance work with the power source turned ON.)
Preparation of work plan
-  **WARNING** Prepare a device that allows operation to be stopped immediately during teaching work. (This also applies to maintenance work with the power source turned ON.)
Setting of emergency stop switch
-  **CAUTION** During teaching work, place a sign indicating that teaching work is in progress on the start switch, etc. (This also applies to maintenance work with the power source turned ON.)
Indication of teaching work in progress
-  **WARNING** Provide a fence or enclosure during operation to prevent contact of the operator and robot.
Installation of safety fence
-  **CAUTION** Establish a set signaling method to the related operators for starting work, and follow this method.
Signaling of operation start
-  **CAUTION** As a principle turn the power OFF during maintenance work. Place a sign indicating that maintenance work is in progress on the start switch, etc.
Indication of maintenance work in progress
-  **CAUTION** Before starting work, inspect the robot, emergency stop switch and other related devices, etc., and confirm that there are no errors.
Inspection before starting work

The points of the precautions given in the separate "Safety Manual" are given below. Refer to the actual "Safety Manual" for details.

-  **CAUTION** Use the robot within the environment given in the specifications. Failure to do so could lead to a drop or reliability or faults. (Temperature, humidity, atmosphere, noise environment, etc.)
-  **CAUTION** Transport the robot with the designated transportation posture. Transporting the robot in a non-designated posture could lead to personal injuries or faults from dropping.
-  **CAUTION** Always use the robot installed on a secure table. Use in an instable posture could lead to positional deviation and vibration.
-  **CAUTION** Wire the cable as far away from noise sources as possible. If placed near a noise source, positional deviation or malfunction could occur.
-  **CAUTION** Do not apply excessive force on the connector or excessively bend the cable. Failure to observe this could lead to contact defects or wire breakage.
-  **CAUTION** Make sure that the workpiece weight, including the hand, does not exceed the rated load or tolerable torque. Exceeding these values could lead to alarms or faults.
-  **WARNING** Securely install the hand and tool, and securely grasp the workpiece. Failure to observe this could lead to personal injuries or damage if the object comes off or flies off during operation.
-  **WARNING** Securely ground the robot and controller. Failure to observe this could lead to malfunctioning by noise or to electric shock accidents.
-  **CAUTION** Indicate the operation state during robot operation. Failure to indicate the state could lead to operators approaching the robot or to incorrect operation.
-  **WARNING** When carrying out teaching work in the robot's movement range, always secure the priority right for the robot control. Failure to observe this could lead to personal injuries or damage if the robot is started with external commands.
-  **CAUTION** Keep the jog speed as low as possible, and always watch the robot. Failure to do so could lead to interference with the workpiece or peripheral devices.
-  **CAUTION** After editing the program, always confirm the operation with step operation before starting automatic operation. Failure to do so could lead to interference with peripheral devices because of programming mistakes, etc.
-  **CAUTION** Make sure that if the safety fence entrance door is opened during automatic operation, the door is locked or that the robot will automatically stop. Failure to do so could lead to personal injuries.
-  **CAUTION** Never carry out modifications based on personal judgments, or use non-designated maintenance parts.
Failure to observe this could lead to faults or failures.
-  **WARNING** When the robot arm has to be moved by hand from an external area, do not place hands or fingers in the openings. Failure to observe this could lead to hands or fingers catching depending on the posture.

 CAUTION

Do not stop the robot or apply emergency stop by turning the robot controller's main power OFF. If the robot controller main power is turned OFF during automatic operation, the robot accuracy could be adversely affected. Moreover, it may interfere with the peripheral device by drop or move by inertia of the arm.

 CAUTION

Do not turn off the main power to the robot controller while rewriting the internal information of the robot controller such as the program or parameters. If the main power to the robot controller is turned off while in automatic operation or rewriting the program or parameters, the internal information of the robot controller may be damaged.

 CAUTION

Use the network equipments (personal computer, USB hub, LAN hub, etc) confirmed by manufacturer. The thing unsuitable for the FA environment (related with conformity, temperature or noise) exists in the equipments connected to USB, RS-232 or LAN. When using network equipment, measures against the noise, such as measures against EMI and the addition of the ferrite core, may be necessary. Please fully confirm the operation by customer. Guarantee and maintenance of the equipment on the market (usual office automation equipment) cannot be performed.

■ Revision history

Date of print	Specifications No.	Details of revisions
2008-10-29	BFP-A8690	First print.
2009-6-23	BFP-A8690-A	The English expression was corrected. Safety Precautions , 1.1.2 Special specifications , Table 1.3: The list of Option equipment and special specification , Caution of USB devices , 2.6.1 Shipping special specifications , 6.1.7 Examples of safety measures Error in writing was corrected.
2007-07-17	BFP-A8690-B	Parameter AREA*CS was added.
2007-08-04	BFP-A8690-C	CE Marking specification was added.
2009-09-12	BFP-A8690-D	The examples of safety measures (Wiring example 3 ~ 5) were corrected.
2009-10-26	BFP-A8690-E	<ul style="list-style-type: none"> • The figure of key switch in "3.6.3 Door switch function " was corrected. (Error in writing) • The figure of example of safety measures in "6.1.7 Examples of safety measures " was corrected. (connects the enabling switch) • The EC Declaration of Conformity was changed. (Correspond to the EMC directive; 2006/42/EC)
2009-12-04	BFP-A8690-F	<ul style="list-style-type: none"> • Fuse rating of pneumatic hand interface (RZ365/375) was corrected. • The text of "This interface is pre-installed on the controller" in pneumatic hand interface was deleted . • Extended Function Instruction Manual was added.
2010-06-17	BFP-A8690-G	<ul style="list-style-type: none"> • The type name of robot controller was changed with specification change.(CR2Q to CR2QA)
2010-07-27	BFP-A8690-H	<ul style="list-style-type: none"> • Cover packing was added to the consumable part. • The description of protection specification was changed. (The cutting oil which examined was updated, and replacement of the cover packing was added) • EC Declaration of Conformity were added.
2010-08-25	BFP-A8690-J	<ul style="list-style-type: none"> • The input voltage range of the DU2A drive unit was corrected. ("3-phase, AC180 to 253" was the previous.)
2010-10-13	BFP-A8690-K	<ul style="list-style-type: none"> • The dimensions of the hole which draws the power cable were added. (DU2A drive unit) • The EC Declaration of Conformity were added.
2010-11-30	BFP-A8690-L	<ul style="list-style-type: none"> • The EC Declaration of Conformity were added.
2010-12-21	BFP-A8690-M	<ul style="list-style-type: none"> • The sink / source expression of pin assignment of hand input cable was corrected. (Sink / Source are common)
2011-02-02	BFP-A8690-N	<ul style="list-style-type: none"> • The note about temperature of the air to supply for hand was added. • Part code was added to the consumable part.
2011-05-09	BFP-A8690-P	<ul style="list-style-type: none"> • Table 1-4: Recommendation article of the USB cable was corrected. • The pressure of the dry air for pressurization was corrected (error in writing). • The depth in which the screw of the mechanical interface section is tightened was added.
2011-06-01	BFP-A8690-Q	<ul style="list-style-type: none"> • The user's guide was added based on South Korean Radio Law. • Fuse rating of pneumatic hand interface (RZ365/375) was corrected. (error in writing). • The setting value range of parameter SFC*ME and AREA*ME were corrected. (error in writing).
2011-07-01	BFP-A8690-R	<ul style="list-style-type: none"> • The note about the connection of the emergency stop was added.
2012-01-26	BFP-A8690-S	<ul style="list-style-type: none"> • The EC Declaration of Conformity were changed.

Date of print	Specifications No.	Details of revisions
2012-07-11	BFP-A8690-T	<ul style="list-style-type: none"> • The "Emergency stop output" in the controller standard specification table was deleted. (Overlapped with "Robot error output".) • The "Table 3-3 : Emergency stop/Door switch input" in "3.4 External input/output" was deleted. (Overlapped with "Table 3-5 : Special input/output terminal".) • The Effective sectional area of the solenoid valve (optional) was corrected. (Error in writing) • The EC Declaration of Conformity were changed. • The notes about frequent installation and removal of TB and the dummy connector were added. • The note about the connection of the emergency stop was added. • The explanation about the controller of KC mark specification was added to " ■ Introduction".

■ Introduction

This series is a full-scale industrial vertical multi-joint type robot that is designed for use in machining processes and assembling. This series supports the oil mist environment as standard, offering a variety of specifications including clean specification and long-arm specification.

However, to comply with the target application, a work system having a well-balanced robot arm, peripheral devices or robot and hand section must be structured.

When creating these standard specifications, we have edited them so that the Mitsubishi robot's characteristics and specifications can be easily understood by users considering the implementation of robots. However, if there are any unclear points, please contact your nearest Mitsubishi branch or dealer. Mitsubishi hopes that you will consider these standard specifications and use our robots.

Note that in this specification document the specifications related to the robot arm is described [Page 7, "2 Robot arm"](#), the specifications related to the controller [Page 39, "3 Controller"](#), and software functions and a command list [Page 90, "4 Software"](#) separately.

This document has indicated the specification of the following types robot.

- *RV-6SQ
- *RV-6SQC
- *RV-6SQL
- *RV-6SQLC

About KC mark specifications

This robot acquires certification of KC mark by the special specification (S19).

The external form of drive unit which have KC mark specification is same as the drive unit which described as "CE Marking specification".

Refer to the place described as "CE Marking specification" about the external form of KC mark specification's drive unit.

Especially the places with no distinction are common specifications.

- No part of this manual may be reproduced by any means or in any form, without prior consent from Mitsubishi.
- The contents of this manual are subject to change without notice.
- The specifications values are based on Mitsubishi standard testing methods.
- The information contained in this document has been written to be accurate as much as possible. Please interpret that items not described in this document "cannot be performed." or "alarm may occur".
Please contact your nearest dealer if you find any doubtful, wrong or skipped point.
- This specifications is original.

- Microsoft, Windows, Microsoft Windows NT are either registered trademarks or trademarks of Microsoft Corporation in the United States and/or other countries.

Contents

	Page
1 General configuration	1-1
1.1 Structural equipment	1-1
1.1.1 Standard structural equipment	1-1
1.1.2 Special specifications	1-1
1.1.3 Options	1-1
1.1.4 Maintenance parts	1-1
1.2 Model type name of robot	1-2
1.2.1 How to identify the robot model	1-2
1.2.2 Combination of the robot arm and the controller	1-2
1.3 CE marking specifications	1-2
1.4 Indirect export	1-2
1.5 Instruction manuals	1-2
1.6 Contents of the structural equipment	1-3
1.6.1 Robot arm	1-3
1.6.2 Controller	1-4
1.7 Contents of the Option equipment and special specification	1-5
2 Robot arm	2-7
2.1 Standard specifications	2-7
2.1.1 The counter-force applied to the installation surface	2-8
2.2 Definition of specifications	2-9
2.2.1 Pose repeatability	2-9
2.2.2 Rated load (mass capacity)	2-10
2.2.3 Relationships Among Mass Capacity, Speed, and Acceleration/Deceleration Speed	2-11
(1) Setting Load Capacity and Size (Hand Conditions)	2-11
2.2.4 Vibrations at the Tip of the Arm during Low-Speed Operation of the Robot	2-11
2.2.5 Protection specifications	2-12
(1) Types of protection specifications	2-12
(2) About the use with the bad environment	2-13
2.2.6 Clean specifications	2-14
(1) Types of clean specifications	2-14
2.3 Names of each part of the robot	2-15
2.4 Outside dimensions • Operating range diagram	2-16
(1) RV-6SQ/6SQC	2-16
(2) RV-6SQL/6SQLC	2-18
2.5 Tooling	2-20
2.5.1 Wiring and piping for hand	2-20
2.5.2 Internal air piping	2-21
2.5.3 Internal wiring for the pneumatic hand output cable	2-21
2.5.4 Internal wiring for the hand check input cable (Standard type/Clean type)	2-21
2.5.5 Spare Wiring	2-21
(1) Standard type	2-21
2.5.6 Wiring and piping system diagram for hand	2-22
2.5.7 Electrical specifications of hand input/output	2-24
2.5.8 Air supply circuit example for the hand	2-25
2.6 Shipping special specifications, options, and maintenance parts	2-26
2.6.1 Shipping special specifications	2-26
(1) Machine cable	2-27
2.7 Options	2-28
(1) Machine cable extension	2-29
(2) Changing the operating range	2-31
(3) Solenoid valve set	2-32
(4) Hand input cable	2-34
(5) Hand output cable	2-35
(6) Hand curl tube	2-36
2.8 About Overhaul	2-37

Contents

	Page
2.9 Maintenance parts	2-37
3 Controller	3-39
3.1 Standard specifications	3-39
3.1.1 Standard specifications	3-39
3.1.2 Protection specifications and operating supply	3-41
3.2 Names of each part	3-42
3.2.1 Names of each part of the drive unit	3-42
(1) Padlock specification	3-44
3.2.2 Names of each part of the robot CPU	3-48
3.3 Outside dimensions/Installation dimensions	3-49
3.3.1 Outside dimensions	3-49
(1) Drive unit outside dimension	3-49
(2) Outside dimensions of robot CPU unit	3-53
(3) Battery unit outside dimension	3-54
3.3.2 Installation dimensions	3-55
(1) Installation dimensions of drive unit	3-55
(2) Robot CPU Unit installation dimensions	3-57
3.3.3 Cable lead-in and dimension	3-58
3.4 External input/output	3-60
3.4.1 Types	3-60
3.5 Dedicated input/output	3-61
3.6 Emergency stop input and output etc.	3-63
3.6.1 Connection of the external emergency stop	3-63
3.6.2 Special stop input(SKIP)	3-67
3.6.3 Door switch function	3-69
3.6.4 Enabling device function	3-69
(1) When door is opening	3-69
(2) When door is closing	3-69
(3) Automatic Operation/Jog Operation/Brake Release and Necessary Switch Settings	3-70
3.7 Additional Axis Function	3-71
3.7.1 Wiring of the Additional Axis Interface	3-71
3.8 Magnet contactor control connector output (AXMC) for addition axes	3-76
3.9 Options	3-79
(1) Teaching pendant (T/B)	3-80
(2) Pneumatic hand interface	3-83
(3) RT ToolBox2/RT ToolBox2 mini	3-86
(4) Instruction Manual(bound edition)	3-88
3.10 Maintenance parts	3-89
4 Software	4-90
4.1 List of commands	4-90
4.2 List of parameters	4-93
5 Instruction Manual	5-95
5.1 The details of each instruction manuals	5-95
6 Safety	6-97
6.1 Safety	6-97
6.1.1 Self-diagnosis stop functions	6-97
6.1.2 External input/output signals that can be used for safety protection measures	6-98
6.1.3 Precautions for using robot	6-98
6.1.4 Safety measures for automatic operation	6-99
6.1.5 Safety measures for teaching	6-99
6.1.6 Safety measures for maintenance and inspections, etc.	6-99
6.1.7 Examples of safety measures	6-100

Contents

	Page
(1) External emergency stop connection [supplementary explanation]	6-104
6.2 Working environment	6-105
6.3 Precautions for handling	6-105
7 Appendix	Appendix-107
Appendix 1 : Specifications discussion material	Appendix-107

1 General configuration

1.1 Structural equipment

Structural equipment consists of the following types.

1.1.1 Standard structural equipment

The following items are enclosed as a standard.

- (1) Robot arm
- (2) Controller(CPU unit + Drive unit)
- (3) The connecting cable for the CPU unit and the drive unit
- (4) Machine cable
- (5) Robot arm installation bolts
- (6) Safety manual, Instruction manual, CD-ROM (Instruction manual)
- (7) Guarantee card

1.1.2 Special specifications

For the special specifications, some standard configuration equipments and specifications have to be changed before factory shipping. Confirm the delivery date and specify the special specifications at the order.

1.1.3 Options

User can install options after their delivery.

1.1.4 Maintenance parts

Materials and parts for the maintenance use.

1.2 Model type name of robot

1.2.1 How to identify the robot model

RV-6SQ L C -Sxx
 (a) (b) (c) (d)

- (a). RV-6SQ Indicates the RV-6SQ series.
- (b). L Indicates long arm type.
 Examples)
 Blank: Standard type.
 L: Long arm type.
- (c). C Indicates environment specification.
 Examples)
 Blank: Standard Specifications
 C: Clean Specifications
- (d). -Sxx [1] Indicates a special model number. In order, limit special specification.
 [2] -SM6** Indicates a specification with protection specification controller.

1.2.2 Combination of the robot arm and the controller

Table 1-1 : Combination of the robot arm and the controller

Protection specification	Robot arm		Controller
Standard specification	RV-6SQ/6SQC	standard arm	CR2QA-711
	RV-6SQL/6SQLC	Long arm	
-SM	RV-6SQ-SM600	standard arm	CR3Q-711M ^{Note1)}
	RV-6SQL-SM600	Long arm	

Note1) The DU3-711M is protection specification. (IP54) Especially, strengthened the protection performance to oil mist.

1.3 CE marking specifications

The RV-6SQ series provides models with CE marking specifications as well.

Table 1-2 : Robot models with CE marking specifications

Robot type	Controller	External signal logic	Language setting
RV-6SQ-S12/6SQC-S12, RV-6SQL-S12/6SQC-S12	CR2QA-711-S12	Source type	English (ENG)
RV-6SQ-SM612/6SQL-SM612	CR3Q-711-SM612		

1.4 Indirect export

The display in English is available by setting parameter LNG as "ENG."

1.5 Instruction manuals

The instruction manuals supplied in CD-ROM, except for the Safety Manual. This CD-ROM (electronic manual) includes instruction manuals in both Japanese and English versions.

1.6 Contents of the structural equipment

1.6.1 Robot arm

The list of structural equipment is shown in Fig. 1-1.

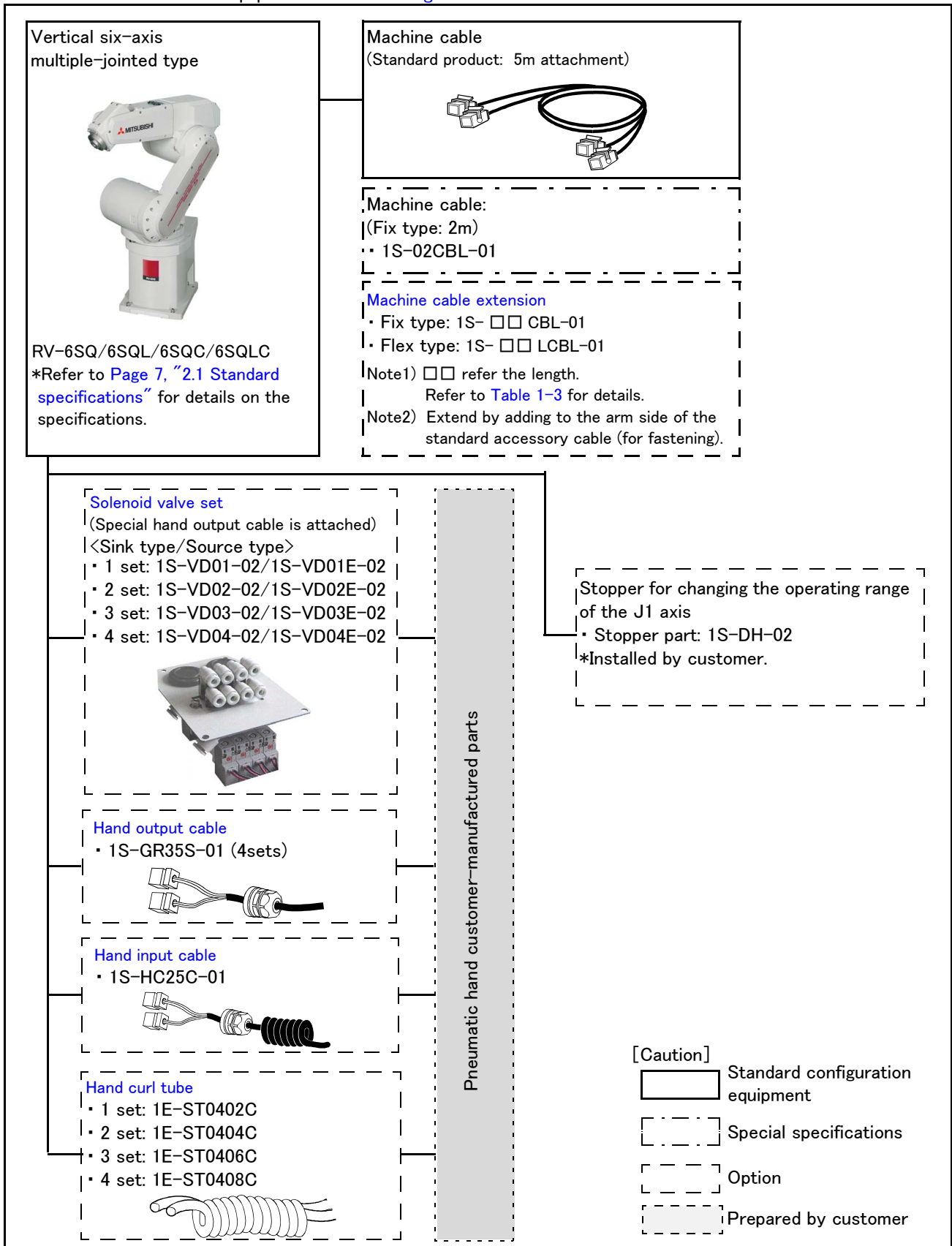

Fig.1-1 : Structural equipment (Robot arm)

1.6.2 Controller

The devices shown below can be installed on the controller.

The controllers that can be connected differ depending on the specification of the robot.

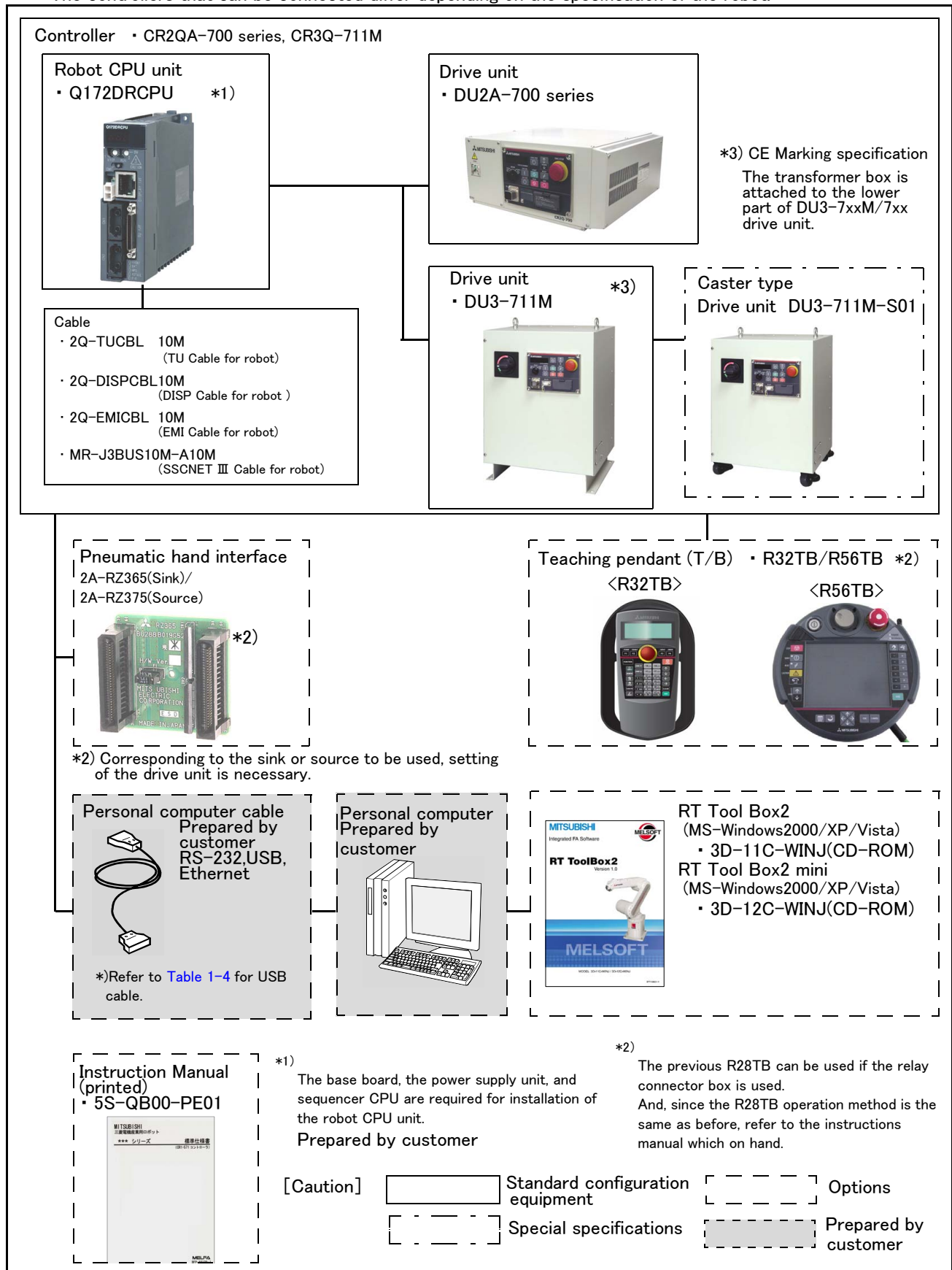

Fig.1-2 : Structural equipment

1.7 Contents of the Option equipment and special specification

A list of all Optional equipments and special specifications are shown below.

Table 1-3 : The list of Option equipment and special specification

Item	Type	Specifications	Classification Note1)	Description
Stopper for changing the operating range of the J1 axis	1S-DH-02	Stopper part One each of the following can be selected. + side: +135, +90, or +45 deg. - side: -135, -90, or -45 deg. ± 170 deg. are used for the standard specification.	○	This must be installed by the customer.
Machine cable(Replaced with shorter cable) ^{Note2)}	1S-02UCBL-03	For fixing (Set of power and signal)	○ · □	2m(A 2 m cable is supplied instead of the 5 m cable that is supplied as standard)
Extended machine cable	1S- □ □ CBL-01	For fixing (Set of power and signal)	○	5, 10, 15m
	1S- □ □ LCBL-01	For bending (Set of power and signal)	○	5, 10, 15m
Solenoid valve set	1S-VD01-02/ 1S-VD01E-02	1 set (Sink type)/(Source type)	○	A solenoid valve set for the pneumatic hand
	1S-VD02-02/ 1S-VD02E-02	2 set (Sink type)/(Source type)	○	
	1S-VD03-02/ 1S-VD03E-02	3 set (Sink type)/(Source type)	○	
	1S-VD04-02/ 1S-VD04E-02	4 set (Sink type)/(Source type)	○	
Hand output cable	1S-GR35S-01	Robot side: connector. Hand side: wire.	○	The cable is connected to the hand output connector by the customer.
Hand input cable	1S-HC25C-01	Robot side: connector. Hand side: wire.	○	The cable is connected to the sensor by the customer.
Hand curl tube	1E-ST0402C	For solenoid valve 1set:Φ4x2	○	Curl type air tube
	1E-ST0404C	For solenoid valve 2set:Φ4x4	○	
	1E-ST0406C	For solenoid valve 3set:Φ4x6	○	
	1E-ST0408C	For solenoid valve 4set:Φ4x8	○	
Simple teaching pendant	R32TB	Cable length 7m	○	With 3-position deadman switch IP65
	R32TB-15	Cable length 15m	○	
Highly efficient teaching pendant	R56TB	Cable length 7m	○	
	R56TB-15	Cable length 15m	○	
Pneumatic hand interface	2A-RZ365	DO: 8 point(Sink type)	○	It is necessary when the hand output signal of the robot arm is used.
	2A-RZ375	DO: 8 point(Source type)	○	
Controller specification with countermeasure against oil mist	CR3Q-700M	Floor type, Closed type (IP54)	□	
Caster specifications controller	CR3Q-700M	Specifications with casters	□	The controller height will be h =615
RT ToolBox2 (Personal computer Support software)	3D-11C-WINE	CD-ROM	○	MS-Windows2000/XP/Vista (With the simulation function)
RT ToolBox2 mini (Personal computer Support software mini)	3D-12C-WINE	CD-ROM	○	MS-Windows2000/XP/Vista
TU cable for robot	2Q-TUCBL □ M	Cable length 05、 10、 20、 30m	○	For communication between robot CPU and DU.
DISP cable for robot	2Q-DISPCBL □ M	Cable length 05、 10、 20、 30m	○	For communication between robot CPU and DU.
EMI cable for robot	2Q-EMICBL □ M	Cable length 05、 10、 20、 30m	○	For a robot CPU emergency stop input.
SSCNET III cable for robot	MR-J3BUS □ M-A	Cable length 05、 10、 20m	○	For the servo communication between robot CPU and DU .
	MR-J3BUS30M-B	Cable length 30m	○	
Instruction Manual	5S-QB00-PE01	RV-6SQ/6SQL series	○	A set of the instructions manual bookbinding editions

Note1) ○ : option, □ : special specifications.

Note2) This option only applies to the CR2DA-700 series controller.

[Reference]:The recommendation products of the USB cable are shown below.

Table 1-4 : Recommendation article of the USB cable

Name	Type name	Supplier
USB cable (USB A type-USB mini B type)	KU-AMB530	SANWA SUPPLY INC.
	USB-M53	ELECOM CO., LTD.
	GT09-C30USB-5P	MITSUBISHI ELECTRIC SYSTEM & SERVICE CO., LTD.
	MR-J3USBCBL3M	MITSUBISHI ELECTRIC CO., LTD.
USB adapter (USB B type-USB mini B type)	AD-USBBFTM5M	ELECOM CO., LTD.

 **Caution** Be careful to the USB cable to apply neither the static electricity nor the noise. Otherwise, it becomes the cause of malfunction.

 **Caution** Use the network equipments (personal computer, USB hub, LAN hub, etc) confirmed by manufacturer. The thing unsuitable for the FA environment (related with conformity, temperature or noise) exists in the equipments connected to USB, RS-232 or LAN. When using network equipment, measures against the noise, such as measures against EMI and the addition of the ferrite core, may be necessary. Please fully confirm the operation by customer. Guarantee and maintenance of the equipment on the market (usual office automation equipment) cannot be performed.

2 Robot arm

2.1 Standard specifications

Table 2-1 : Standard specifications of robot

Item		Unit	Specifications			
Type			RV-6SQ	RV-6SQC	RV-6SQL	RV-6SQLC
Type of robot			6-axis standard arm		6-axis long arm	
			Standard	Clean (Special Specifications)	Standard	Clean (Special Specifications)
Degree of freedom			6			
Installation posture			On floor, hanging (against wall ^{Note1})	On floor	On floor, hanging (against wall ^{Note1})	On floor
Structure			Vertical, multiple-joint type			
Drive system			AC servo motor (brake provided on all axes)			
Position detection method			Absolute encoder			
Arm length	Upper arm	mm	280		380	
	Fore arm		315		425	
Operating range	Waist (J1)	Degree	340(-170 to +170)			
	Shoulder (J2)		227(-92 to +135)			
	Elbow (J3)		273(-107 to +166)		295(-129 to +166)	
	Wrist twist (J4)		320(-160 to +160)			
	Wrist pitch (J5)		240(-120 to +120)			
	Wrist roll (J6)		720(-360 to +360)			
Speed of motion	Waist (J1)	Degree/ s	401		250	
	Shoulder (J2)		321		267	
	Elbow (J3)		401		267	
	Wrist twist (J4)		352			
	Wrist pitch (J5)		450			
	Wrist roll (J6)		660			
Maximum resultant velocity ^{Note2)}		mm/sec	Approx. 9,300		Approx. 8,500	
Load	Maximum ^{Note3)}	kg	6 (58.8)			
	Rating	(N)	5 (49.0)			
Pose repeatability ^{Note4)}		mm	±0.02			
Ambient temperature		°C	0 to 40			
Mass		kg	Approx. 58		Approx. 60	
Allowable moment load	Wrist twist (J4)	N · m	12			
	Wrist pitch (J5)		12			
	Wrist roll (J6)		4.5			
Allowable inertia	Wrist twist (J4)	kg · m ²	0.29			
	Wrist pitch (J5)		0.29			
	Wrist roll (J6)		0.046 ^{Note5)}			
Arm reachable radius front p-axis center point		mm	696		902	
Tool wiring ^{Note6)}			Hand input 8 point / hand output 8 point Eight spare wires : AWG#27(0.1mm ²) (shielded)			
Tool pneumatic pipes			Primary side: Φ6 × 2 (Base to fore arm section)			
Supply pressure		MPa	0.49 ± 10%			
Protection specification ^{Note7)}			J1 to J3 axis : IP54 J4 to J6 axis : IP65	–	J1 to J3 axis : IP54 J4 to J6 axis : IP65	–
Degree of cleanliness ^{Note8)}			–	10(0.3 μm) Internal suction requirement	–	10(0.3 μm) Internal suction requirement
Painting color			Light gray (Equivalent to Munsell: 0.08GY7.64/0.81)			

Note1) When used by mounting on the wall, a special specification that limits the operating range of the J1 axis will be used. Please give an order separately.

Note2) This is the value on the mechanical interface surface when all axes are combined.

Note3) The maximum load capacity is the mass with the mechanical interface posture facing down word at the ±10° limit.

Note4) The pose repeatability details are given in [Page 9, "2.2.1 Pose repeatability"](#)

Note5) Up to 0.092kg · m² can be supported by performing variable acceleration/deceleration control and also by setting the load inertia.

Note6) The pneumatic hand interface (option) is required when the tool (hand) output is used. Also, if the solenoid set (option) is used, eight points of hand outputs are used for other options.

Note7) The protection specification details are given in [Page 12, "2.2.5 Protection specifications"](#).

Note8) The clean specification details are given in [Page 14, "2.2.6 Clean specifications"](#). A down flow(0.3m/s or more) in the clean room is the necessary conditions for the cleanliness.

2.1.1 The counter-force applied to the installation surface

The counter-force applied to the installation surface for the strength design of the robot installation surface is shown.

Table 2-2 : Value of each counter-force

Item	Unit	Value
Falls moment: M_L	N•m	8 9 2
Torsion moment: M_T	N•m	8 9 2
Horizontal translation force: F_H	N	8 0 0
Vertical translation force: F_V	N	1 , 4 0 0

2.2 Definition of specifications

The accuracy of pose repeatability mentioned in catalogs and in the specification manual is defined as follows.

2.2.1 Pose repeatability

For this robot, the pose repeatability is given in accordance with JIS 8432 (Pose repeatability). Note that the value is based on 100 measurements (although 30 measurements are required according to JIS).

[Caution] The specified "pose repeatability" is not guaranteed to be satisfied under the following conditions.

- [1] Operation pattern factors
 - 1) When an operation that approaches from different directions and orientations are included in relation to the teaching position during repeated operations
 - 2) When the speed at teaching and the speed at execution are different
- [2] Load fluctuation factor
 - 1) When work is present/absent in repeated operations
- [3] Disturbance factor during operation
 - 1) Even if approaching from the same direction and orientation to the teaching position, when the power is turned OFF or a stop operation is performed halfway
- [4] Temperature factors
 - 1) When the operating environment temperature changes
 - 2) When accuracy is required before and after a warm-up operation
- [5] Factors due to differences in accuracy definition
 - 1) When accuracy is required between a position set by a numeric value in the robot's internal coordinate system and a position within the actual space
 - 2) When accuracy is required between a position generated by the pallet function *1) and a position within the actual space

*1)

The pallet function is a function that teaches only the position of the work used as reference (3 to 4 points) and obtains the remaining positions by calculations, for an operation that arranges works orderly or for an operation that unloads orderly arranged works. By using this function, for example, in the case of an operation that arranges works on grid points of 100 x 100, by teaching only three points of four corners, the remaining grid points are automatically generated; thus, it is not necessary to teach all 10,000 points. For more information about the pallet function, refer to the separate volume, "Instruction Manual/Detailed Explanation of Functions and Operations."

2.2.2 Rated load (mass capacity)

The robot's mass capacity is expressed solely in terms of mass, but even for tools and works of similar mass, eccentric loads will have some restrictions. When designing the tooling or when selecting a robot, consider the following issues.

- (1) The tooling should have the value less or equal than the smaller of the tolerable inertia and the tolerable moment found in Page 7, "Table 2-1 : Standard specifications of robot"
- (2) Fig. 2-1 shows the distribution dimensions for the center of gravity in the case where the volume of the load is relatively small. Use this figure as a reference when designing the tooling.
- (3) When the load is not mass, but force, you should design the tooling so that it does not exceed the value for allowable moment described in Page 7, "Table 2-1 : Standard specifications of robot"

[Caution] The mass capacity is greatly influenced by the operating speed of the robot and the motion posture. Even if you are within the allowable range mentioned previously, an overload or generate an overcurrnt alarm could occur. In such cases, it will be necessary to change the time setting for acceleration/deceleration, the operating speed, and the motion posture.

[Caution] The overhang amount of the load for the specified moment and inertia in this section is the dynamic limit value determined by the motor driving each axis and by the capacity of the reduction gears. Consequently, accuracy cannot be guaranteed for the entire tooling area. Since accuracy is based on the center point of the mechanical interface surface, position accuracy can diminish as you go away from the mechanical interface surface, or vibration can result, with tooling that is not rigid or that is long.

[Caution] Even within the allowable range previously mentioned, an overload alarm may be generated if an ascending operation continues at a micro-low speed. In such a case, it is necessary to increase the ascending speed.

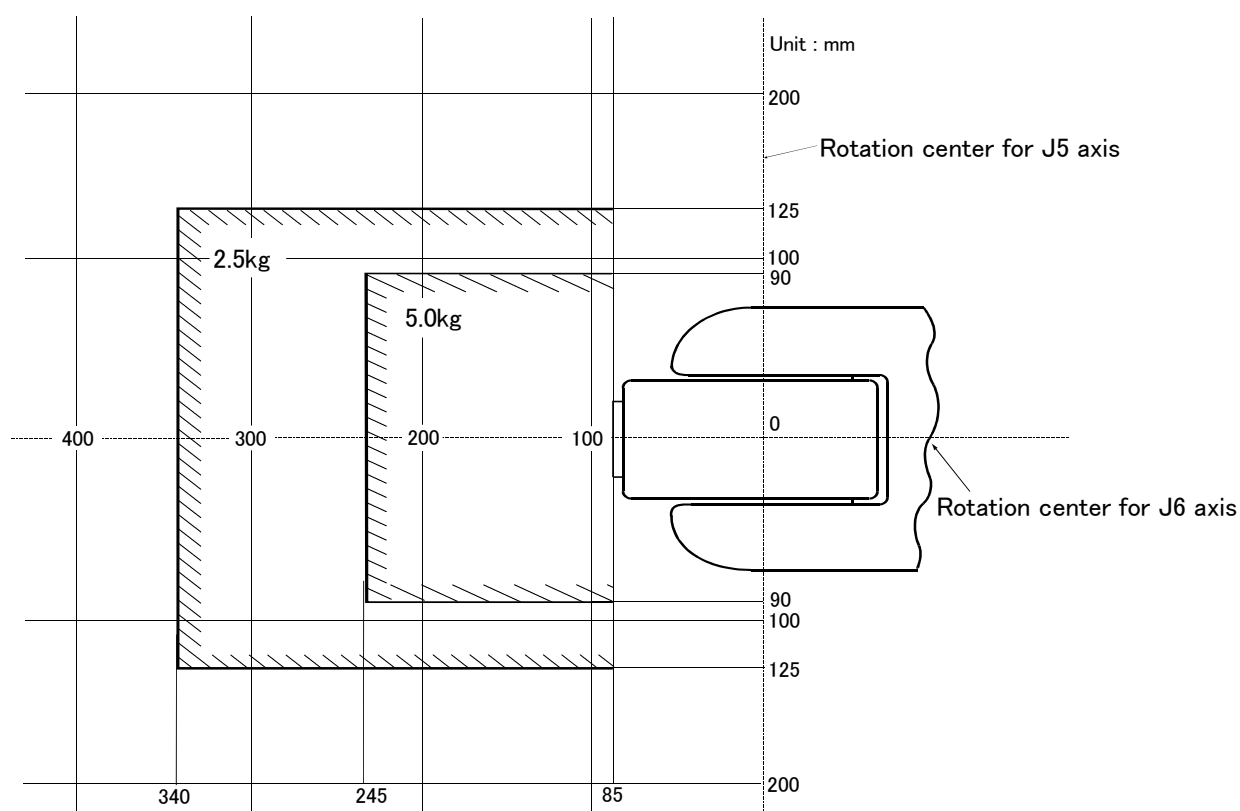

Fig.2-1 : Position of center of gravity for loads (for loads with comparatively small volume):RV-6SQ/6SQL Series

2.2.3 Relationships Among Mass Capacity, Speed, and Acceleration/Deceleration Speed

This robot automatically sets the optimum acceleration and deceleration speeds and maximum speed, according to the load capacity and size that have been set, and operates using these automatically set speeds. To achieve that, it is necessary to correctly set the actual load data (mass and size of hand and work) to be used. However, vibration, overheating and errors such as excessive margin of error and overload may occur, depending on the robot operation pattern or ambient temperature. In such a case, change the setting value to the +20% range. If a setting is performed in such a way that it falls below the mounted load, the life span of the mechanism elements used in the robot may be shortened. In the case of a work requiring a high degree of accuracy, set up the load correctly and use the robot by lowering the ratios of the acceleration and deceleration speeds.

(1) Setting Load Capacity and Size (Hand Conditions)

Set up the capacity and size of the hand with the "HNDDAT*" parameter (optimum acceleration/deceleration setting parameter), and set up the capacity and size of the work with the "WRKDAT*" parameter. Numbers 0 to 8 can be used for the asterisk (*) part. Designate the "HNDDAT*" and "WRKDAT*" parameters to be used using the "LOADSET" command in a program.

For more details, refer to the separate "Instruction Manual/Detailed Explanation of Functions and Operations." It is the same meaning as "LOADSET 0.0" if not using the "LOADSET".

2.2.4 Vibrations at the Tip of the Arm during Low-Speed Operation of the Robot

Vibrations at the tip of the arm may increase substantially during the low-speed operation of the robot, depending on the combination of robot operation, hand mass and hand inertia. This problem occurs when the vibration count specific to the robot arm and the vibration count of the arm driving force are coming close to each other. These vibrations at the tip of the arm can be reduced by taking the following measures:

- 1) Lower the robot's operating speed by approximately 5% from high speed using the OvrD instruction.
- 2) Change and move the teaching points of the robot.
- 3) Change the hand mass and hand inertia.

2.2.5 Protection specifications

(1) Types of protection specifications

The robot arm has protection specifications that comply with the IEC Standards. The protection specifications and applicable fields are shown in [Table 2-3](#).

Table 2-3 : Protection specifications and applicable fields

Type	Protection specifications (IEC Standards value)	Classification	Applicable field	Remarks
RV-6SQ/6SQ-SM RV-6SQL/6SQL-SM	IP54 (J1 to J3 axis)	General-purpose environment specifications	General assembly Slightly dusty environment	
	IP65 (J4 to J6 axis)	Oil mist specifications	Machine tool (cutting) Machine shop with heavy oil mist Dusty work shop	Note that if the cutting machine contains abrasive materials, the robot machine line will be shortened.

We are confirming examining with the cutting oil shown in [Table 2-4](#), and satisfying protection specification. Our warranty does not cover damages or failure resulting from the robot being operated in any environment where other cutting oils than those listed in the table are used (except cutting oils with respect to which the robot's compatibility with the protection specification is verified through our operability evaluation) or where the robot body may be directly splashed with water, oil or dust in quantities greater than stated in the protection specification.

Table 2-4 : Cutting oil which examined as oil mist environment

No.	Name	Maker	Property	Operating condition
1	CastrolHysol X	Castrol Co., Ltd	Water-soluble	Diluted by a factor of 20
2	CastrolSyntilo9954	Castrol Co., Ltd	Water-soluble	Diluted by a factor of 20
3	Yushiron Oil	YUSHIRO CHEMICAL INDUSTRY CO., LTD	Water-insoluble	-
4	YushirokenE10	YUSHIRO CHEMICAL INDUSTRY CO., LTD	Water-soluble	Diluted by a factor of 20
5	Yushiroken synthetic 770TG	YUSHIRO CHEMICAL INDUSTRY CO., LTD	Water-soluble	Diluted by a factor of 20
6	YushirokenFX90	YUSHIRO CHEMICAL INDUSTRY CO., LTD	Water-soluble	Diluted by a factor of 20
7	SUNCUT ES-50N	NIPPON GREASE CO., LTD	Water-insoluble	-
8	Searching cut SG555	KYOUWA OIL LUBRICANTS CO., LTD,	Water-insoluble	-
9	EMULCUT FA-800	KYODO YUSHI CO., LTD	Water-soluble	-

【Information】

• The IEC IP54

The IEC IP54 standard refers to protection structure designed to prevent any harmful effects by fresh water scattering vertically onto the testing equipment in a radius of 180 degrees from a distance of 300 to 500 mm, with 10 ± 0.5 liters of water every minute, at a water pressure of 80 to 100kPa, covering the entire area of the robot with the exception of the installation section at 1 m^2 per minute, for a total of 5 minutes or more.

• The IEC IP65

Protection against water infiltration as specified in IP65 indicates a protective structure that is not harmfully affected when $12.5 \pm 5\%$ liters of water is supplied from a test device at a position approx. 3m away in various directions and a water pressure of 30kPa at the nozzle section. The water is filled one minute per 1 m^2 of test device surface area for a total of three minutes.

The IEC IP symbols define the degree of protection against solids and fluids, and do not indicate a protective structure against the entry of oil or water.

(2) About the use with the bad environment

This robot has protection methods that conform to IEC's IP54 (for J1 to J3 axis) and IP65 (for J4 to J6 axis) standards (splashproof type). Recommended usage conditions.

- 1) The robot is designed for use in combination with machining device.
- 2) We are confirming examining with the cutting oil shown in [Table 2-4](#), and satisfying protection specification. Our warranty does not cover damages or failure resulting from the robot being operated in any environment where other cutting oils than those listed in the table are used (except cutting oils with respect to which the robot's compatibility with the protection specification is verified through our operability evaluation) or where the robot body may be directly splashed with water, oil or dust in quantities larger than stated in the protection specification.
- 3) Take measures so that the robot will not be exposed to water, oil and/or chips for a long period of time.
- 4) Robot's protection performance can be improved by pressurizing its interior. If you use a robot in an environment where oil mist is present, it is recommended that the interior of the robot be pressurized to ensure its reliability over a long period of time. Please supply the dry air for pressurization from the phi-8 joint (AIR PURGE) of the robot-arm base rear.

Table 2-5 : Specification of the dry air for pressurization

Item	Dew point	Pressure
Specification	The atmospheric pressure dew point is -20 degree or less.	0 to 0.01MPa

The packing gets deteriorated with the passage of time and must be replaced as required. [Table 2-6](#) provides guidelines for replacing the packing.

Table 2-6 : Packing replacement guideline

Environment	Whether or not robot is pressurized	When packing must be replaced
General environment	Not pressurized ^{Note1)}	When signs of cracking or peeling are noted in the packing.
Clean room	Not pressurized ^{Note1)}	
Oil mist	Pressurized	
	Not pressurized	When removing and installing the cover.

Note1) The pressurization inside the robot arm is unnecessary in general environment and clean room environment.

Failure to replace deteriorated packing permits water or oil to enter the interior of the robot, possibly causing it to become inoperable.

[Table 2-27](#) lists packings requiring replacement and corresponding robot covers. Packing required and liquid gasket used therewith are available from dealer.

Also, entrained water droplets lead to the formation of rust on the robot, but would not usually affect the robot's ability to operate normally.

The warranty is invalid for any faults that occur when the robot is used under the following conditions.

Also, if the cover and/or other parts are damaged by interferences caused by the peripheral devices and the robot, the protection specification (seal performance, etc.) may be degraded. Therefore, please pay extra attention when handling the robot.

Refer to [Page 105](#), "6.2 Working environment".

- 1) In surroundings that generate inflammable gases or corrosive gasses.
- 2) Atmosphere used excluding cutting oil shown in [Table 2-4](#).
- 3) Environment where the robot is exposed to water, oil and/or chips for a long period of time.
- 4) In surroundings where chips fall directly on the robot. In surroundings where the minimum diameter of chips is less than 0.5mm.
- 5) Mist atmosphere exceeding the specification.
- 6) Pressurization by the dry air exceeding the specification of [Table 2-5](#)

2.2.6 Clean specifications

(1) Types of clean specifications

The robot arm with clean specification is made by order. Please check the delivery schedule.

Table 2-7 : Clean specifications

Type	Degree of cleanliness	Internal suction	Remarks
RV-6SQ RV-6SQLC	10(0.3 μm)	Concentrated suction with vacuum generating valve. Use it in the clean room with the down flow (flow velocity 0.3 m/s above).	The use of a vacuum generating valve is recommended.

■ Precautions for use

- 1) When using a device that moves or rotates the robot arm, the down flow may not be secured because of the air flow. In this case, the degree of cleanliness cannot be ensured.
- 2) A ϕ 8 coupling is provided in the base section of the robot arm for suction inside the robot arm. When using the robot, connect this coupling with the vacuum generating valve and vacuum pump (furnished by the customer).

[1]When the inside of the robot arm is sucked using the vacuum generator.

Table 2-8 : Specifications of vacuum generation valve (Confirmed in our company)

Type	Maker	Air pressure ^{Note1)}
MEDT 14	KONEGAI CORPORATION	<ul style="list-style-type: none"> • Vacuum rate (supply pressure is 0.5MPa): 96l. / min • Ultimate vacuum (supply pressure is 0.5MPa): -84KPa

Note1) Install the vacuum generating valve downstream of the downflow or install a filter in the exhaust air section so that the exhaust air from the vacuum generating valve does not affect cleanliness.
Recommended filter: Exhaust filter EF300-02, Koganei Corporation

[2]If any vacuum pump is prepared by the customer, assure on the vacuum side flow rate 30 liters/min.(ANR) or more.

- 3) When using the Mitsubishi standard option solenoid valve set, use the spare piping (Φ 6 pneumatic hose) of the primary piping to exhaust the air.
If the exhaust leaks into the robot arm, the degree of cleanliness could be affected.

2.3 Names of each part of the robot

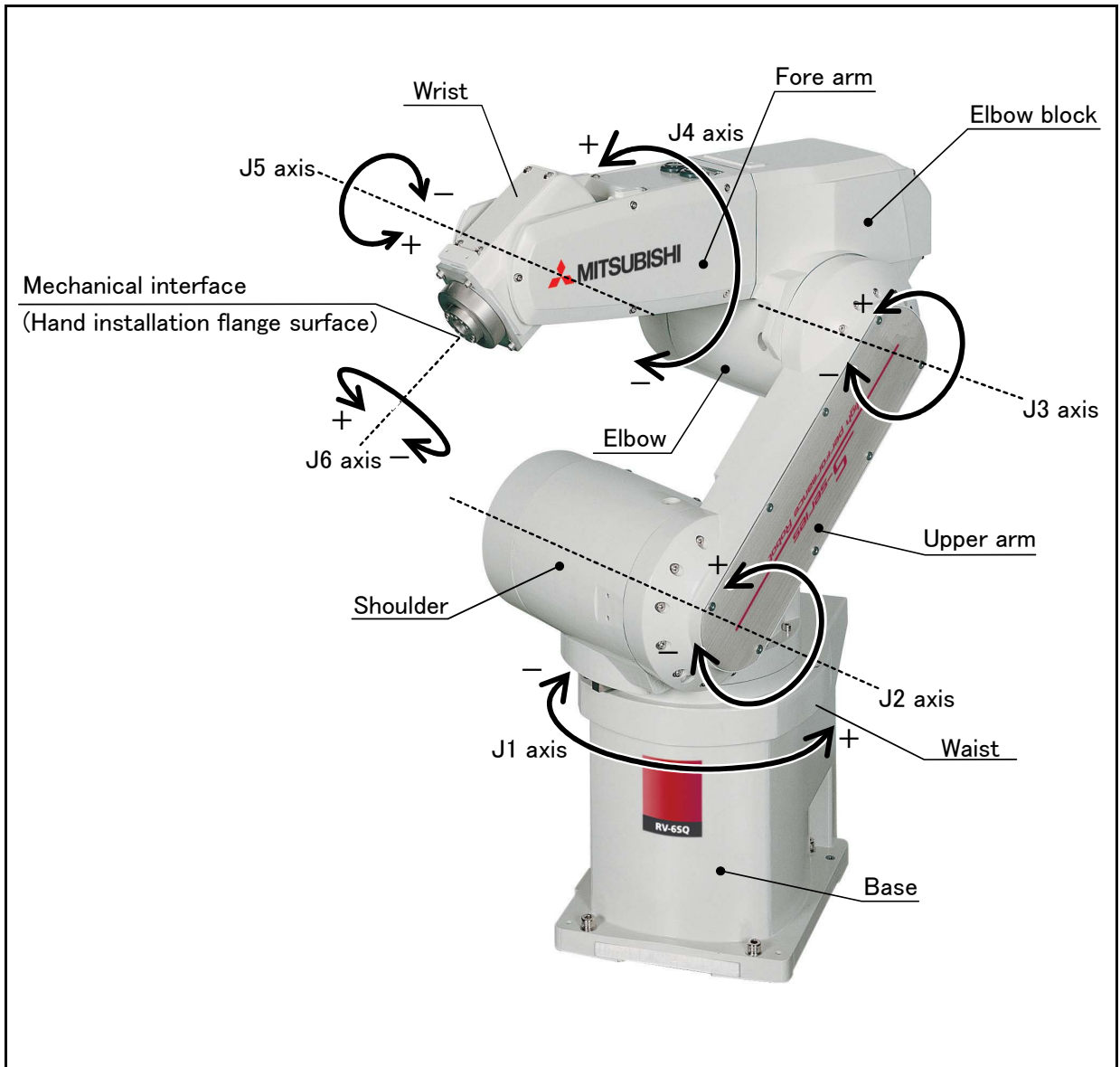

Fig.2-2 : Names of each part of the robot

2.4 Outside dimensions • Operating range diagram

(1) RV-6SQ/6SQC

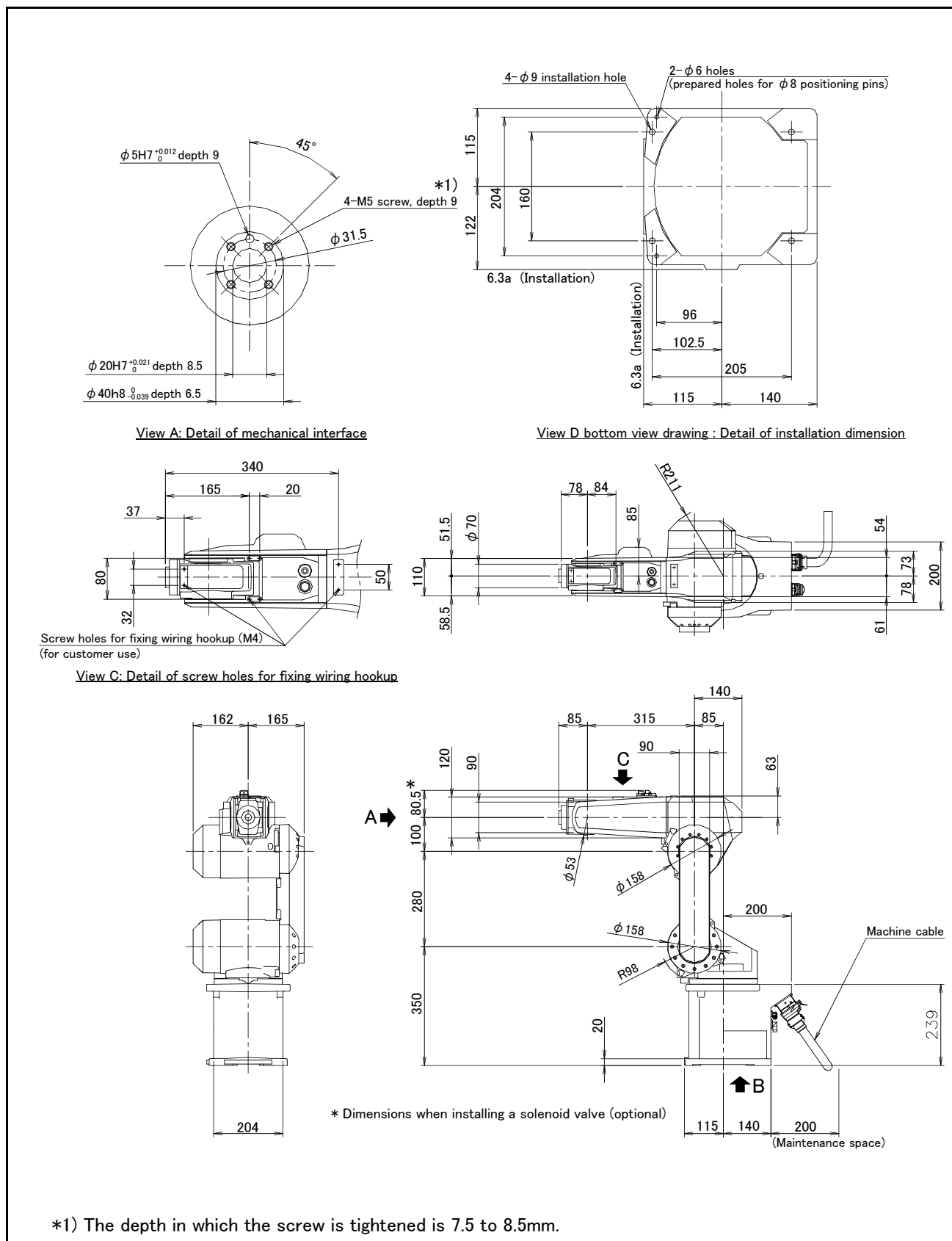

Fig.2-3 : Outside dimensions : RV-6SQ/6SQC

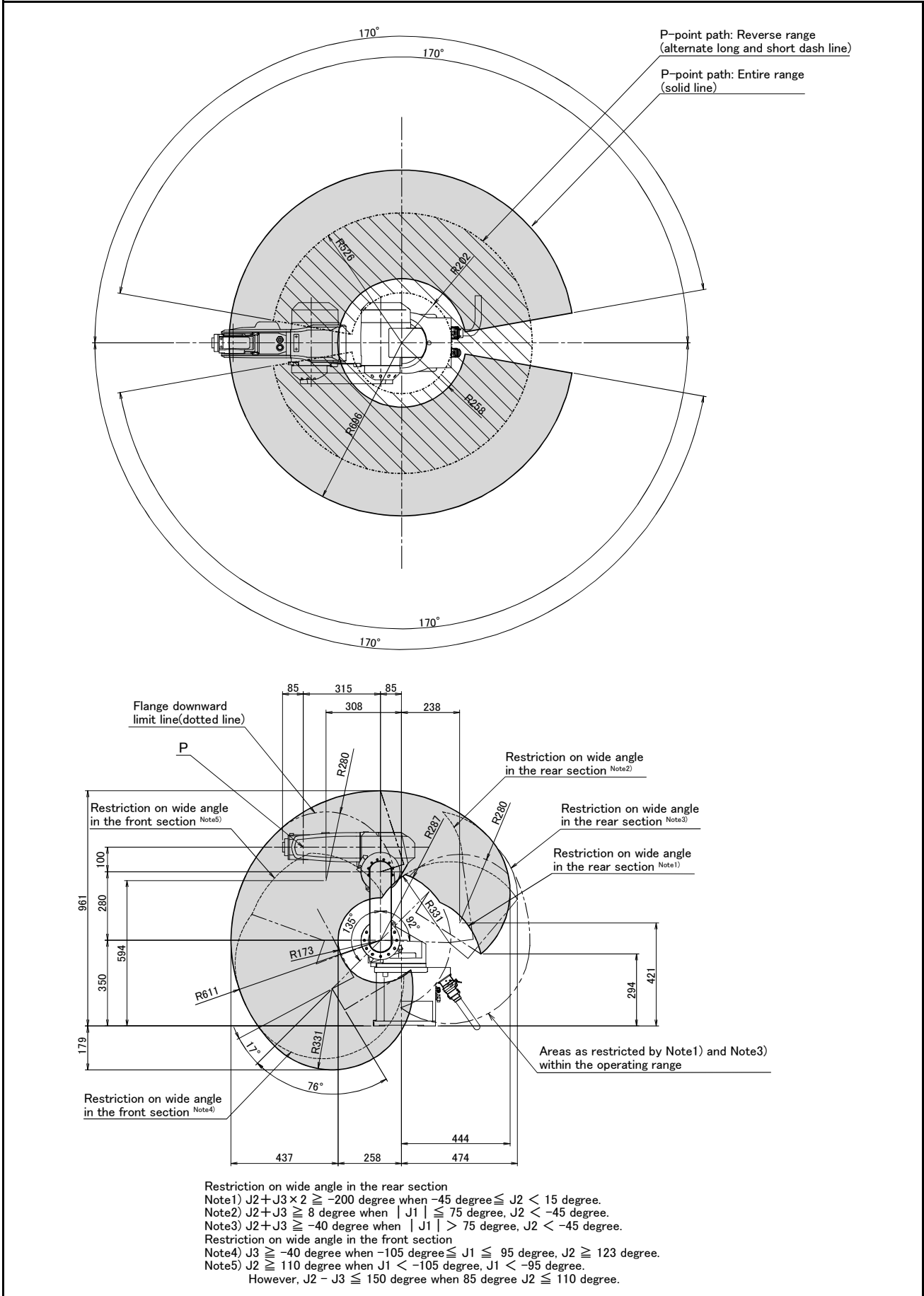

Fig.2-4 : Operating range diagram : RV-6SQ/6SQC

(2) RV-6SQL/6SQLC

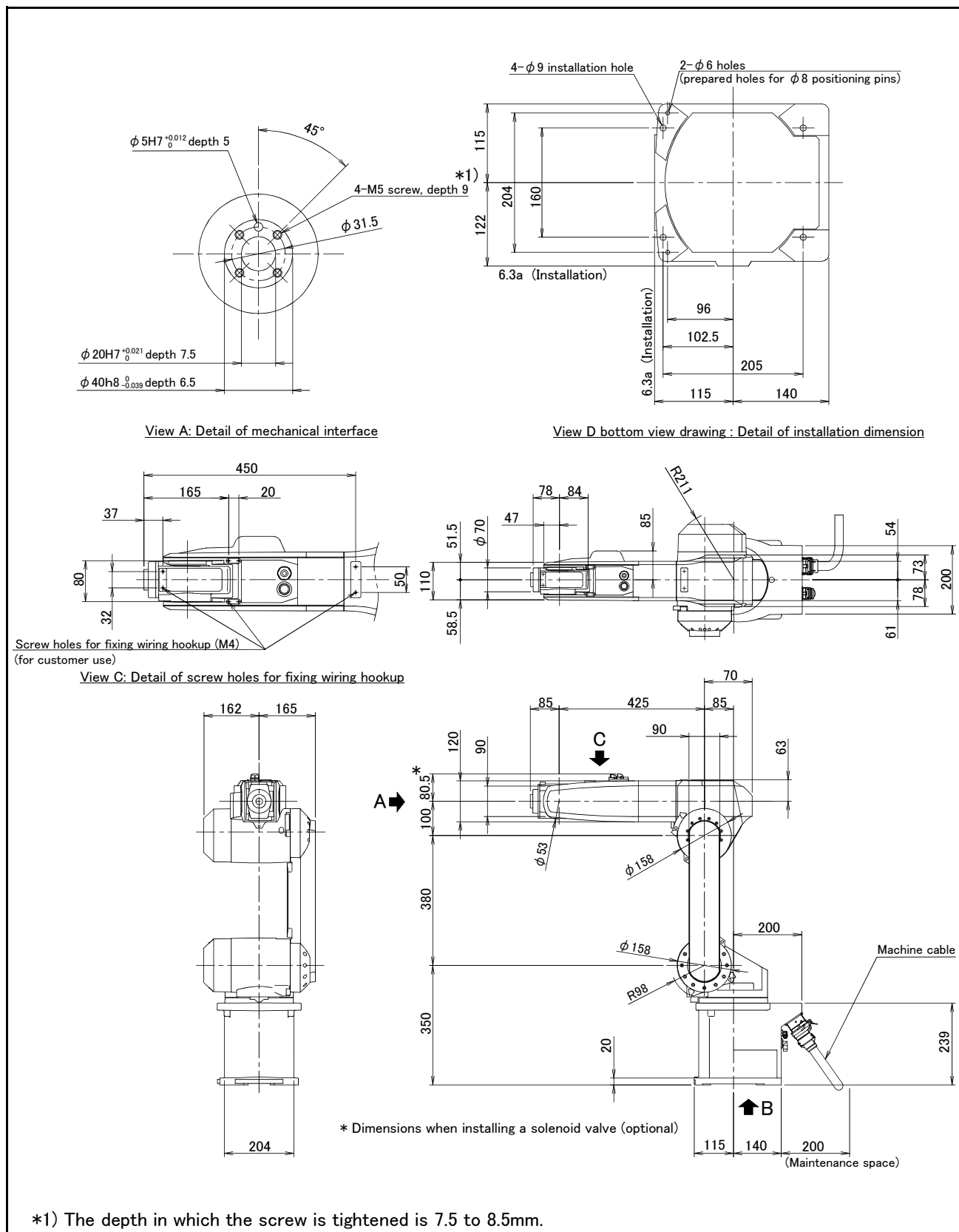
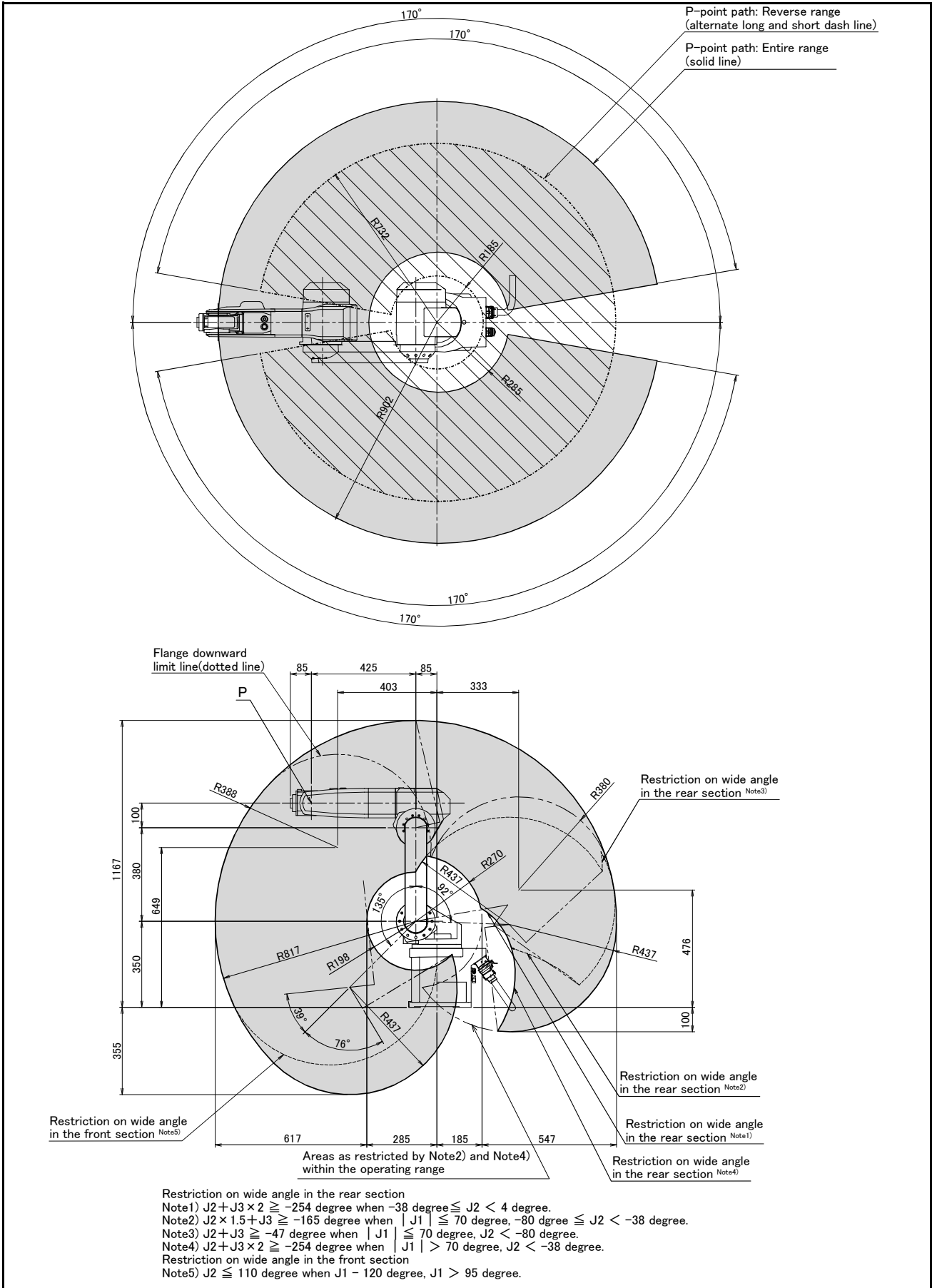

Fig.2-5 : Outside dimensions : RV-6SQL/6SQLC



Operating range diagram : RV-6SQL/6SQLC

2.5 Tooling

2.5.1 Wiring and piping for hand

Shows the wiring and piping configuration for a standard-equipped hand.

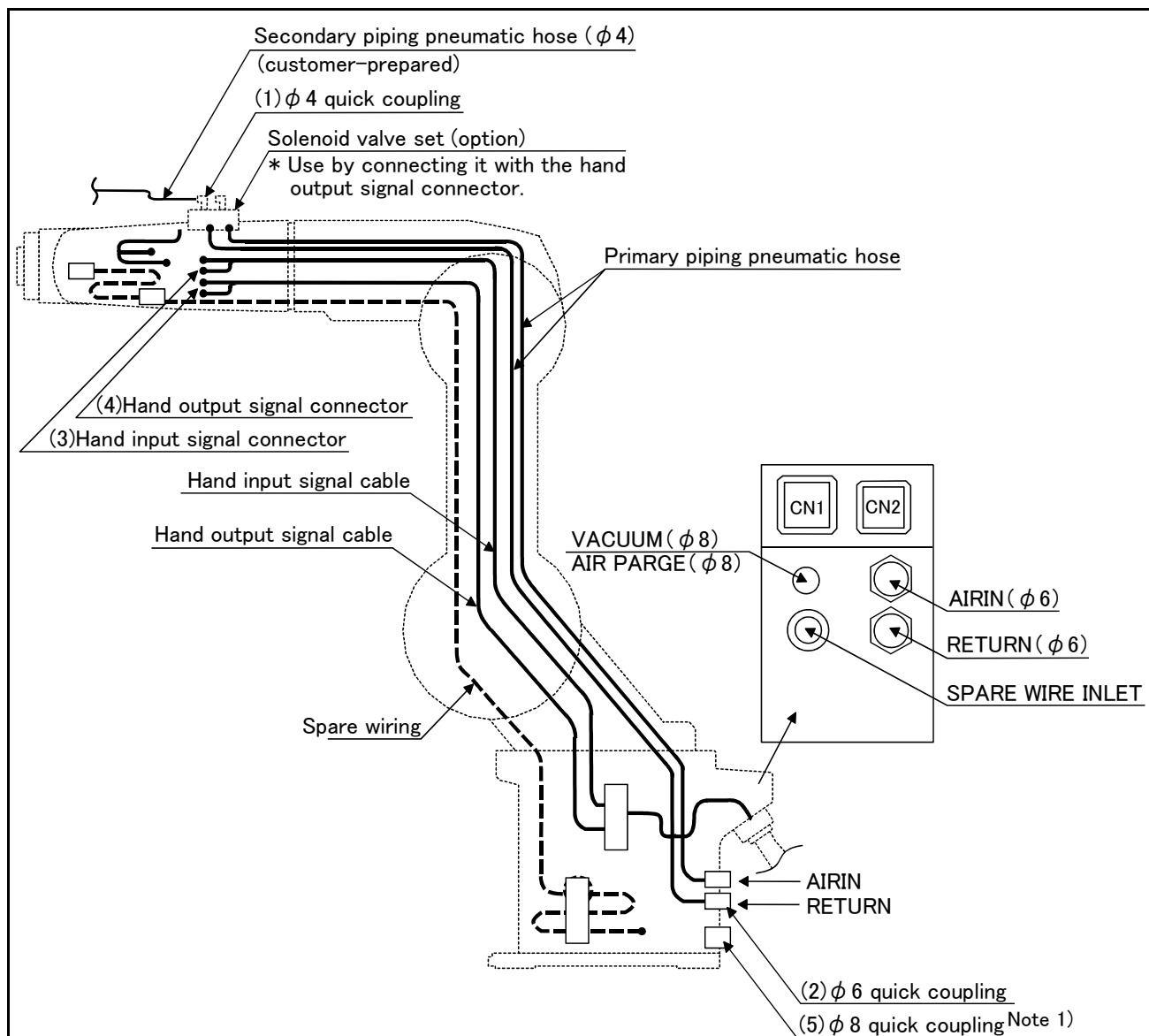

Connector and pneumatic coupling

No	Name	Qty.	Robot side (Robot arm side)		Counter side (customer-prepared)		Manufacturer
			Connectors, couplings	Connector pins	Connector	Connector pins	
(1)	Coupling	4	KJW04-M3	—	—	—	SMC Corporation
		4	KJL04-M3	—	—	—	
(2)	Coupling	2	UKBL6	—	—	—	Koganei Corporation
(3)	Connector	2	1-1717834-3	1318108-1	1-1318115-3	1318112-1	Tyco Electronics AMP K.K.
(4)	Connector	2	1-1717834-4	1318108-1	1-1318115-4	1318112-1	Tyco Electronics AMP K.K.
(5)	Coupling Note1)	1	UKBL8	—	—	—	Koganei Corporation

Note1) For internal suction in the clean specification, or for AIR PARGE in protection specifications.

Fig.2-6 : Wiring and piping for hand

2.5.2 Internal air piping

1) Standard specification

- The robot has two $\phi 6 \times 4$ urethane hoses from the pneumatic entrance on the base section to the shoulder cover.
- One hose is the primary piping for the pneumatic equipment. The remaining pipe is used for air exhaust.
- The optional solenoid is provided with a maximum of eight couplings for the $\phi 4$ air hose.
- The pneumatic inlet in the base section has a $\phi 6$ pneumatic coupling bridge.
- Refer to Page 32, "(3) Solenoid valve set" for details on the electronic valve set (optional).
- Protection performance can be improved by pressurizing the inside of the robot arm. Since the joint (AIR PURGE) of $\phi 8$ is prepared at the rear of the base section, please supply the dry air for pressurization from this joint. Refer to Page 12, "2.2.5 Protection specifications" for the details of dry air.

2) Clean specification

- The clean type basically includes the same piping as the standard type.
- With the clean specification, a $\phi 8$ coupling is provided in the base section for suction inside the machine. For use, connect it to the suction port of the vacuum pump or the coupling on the "VACUUM" side of the vacuum generating valve. Moreover, to clean the exhaust from the vacuum pump or vacuum generator, use the exhaust filter (prepared by the customer).
- Refer to Page 14, "2.2.6 Clean specifications" for details of the vacuum for suction.
- Use clean air as the air supplied to the vacuum generator.

2.5.3 Internal wiring for the pneumatic hand output cable

When the controller uses the optional pneumatic hand interface (2A-RZ365/2A-RZ375), the hand output signal works as the pneumatic hand cable.

- The hand output primary cable extends from the connector PCB of the base section to the inside of the forearm. (AWG#24(0.2mm²)x 2 : 8 cables) The cable terminals have connector bridges for eight hand outputs. The connector names are GR1 and GR2.
To extend the wiring to the outside of the arm, a separate cable (optional "hand output cable 1S-GR35S-01")

2.5.4 Internal wiring for the hand check input cable (Standard type/Clean type)

- The hand input cable extends from the connector PCB of the base section to the inside of the forearm. (AWG#24(0.2mm²)x 2 : 8 cables) The cable terminals have connector bridges for eight hand inputs. The connector names are HC1 and HC2.
- The hand check signal of the pneumatic hand is input by connecting this connector.
To extend the wiring to the outside of the arm, a separate cable (optional "hand input cable "1S-HC25C-01" IP65 is recommended) is required.

2.5.5 Spare Wiring

(1) Standard type

As spare wiring, four pairs of cab tire cables (AWG#28(0.2mm²) total is eight cores) are preinstalled between the base section and the forearm side section. Customer can utilize it. Refer to the separate "Instruction Manual/ROBOT ARM SETUP & MAINTENANCE" for details.

Both ends of the wire terminals are unprocessed. Use them under the following circumstances:

- For folding as the hand output cable when installing the solenoid valve in outside the robot.
- For when installing six or more hand I/O points for the sensor in the hand section (Connects to the parallel I/O general purpose input.)

Reference) Pin assignment of the connector, and the matching connector

Pin assignment

Pin	Color
A1	Red
A2	Brown
A3	Green
A4	Black
B1	Orange
B2	White
B3	Yellow
B4	Blue

Robot side connector

Connection place	Connector	Contactora	Maker
Base portion	2-1318115-4	-	Tyco Electronics AMP K.K.
Fore arm portion	2-1717834-4	-	

Other party connector (recommendation)

Connection place	Connector	Contactora	Maker
Base portion	2-1717834-4	1318108-1	Tyco Electronics AMP K.K.
Fore arm portion	2-1318115-4	1318112-1	

2.5.6 Wiring and piping system diagram for hand

Shows the wiring and piping configuration for a standard-equipped hand.

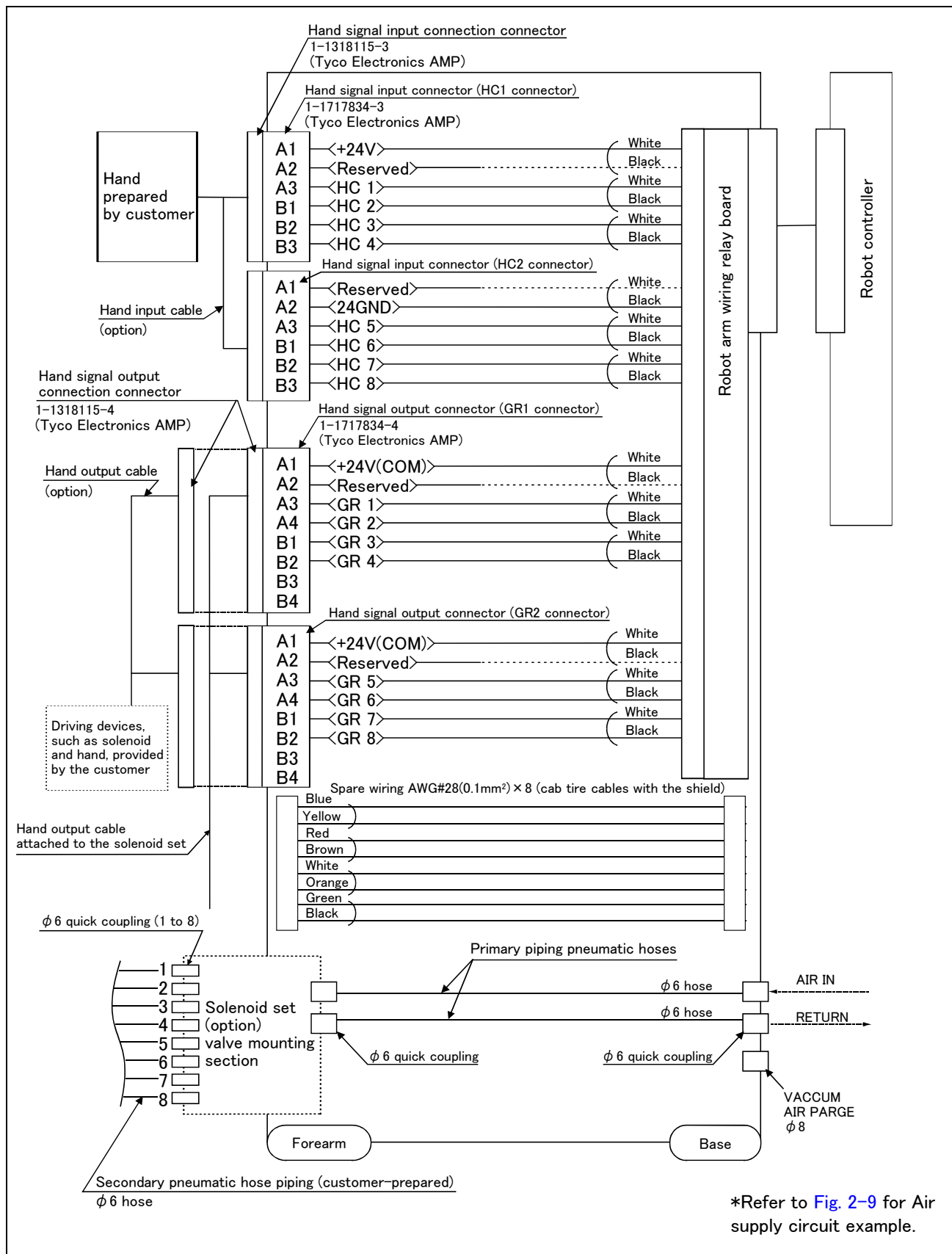

Fig.2-7 : Wiring and piping system diagram for hand and example the solenoid valve installation(Sink type)

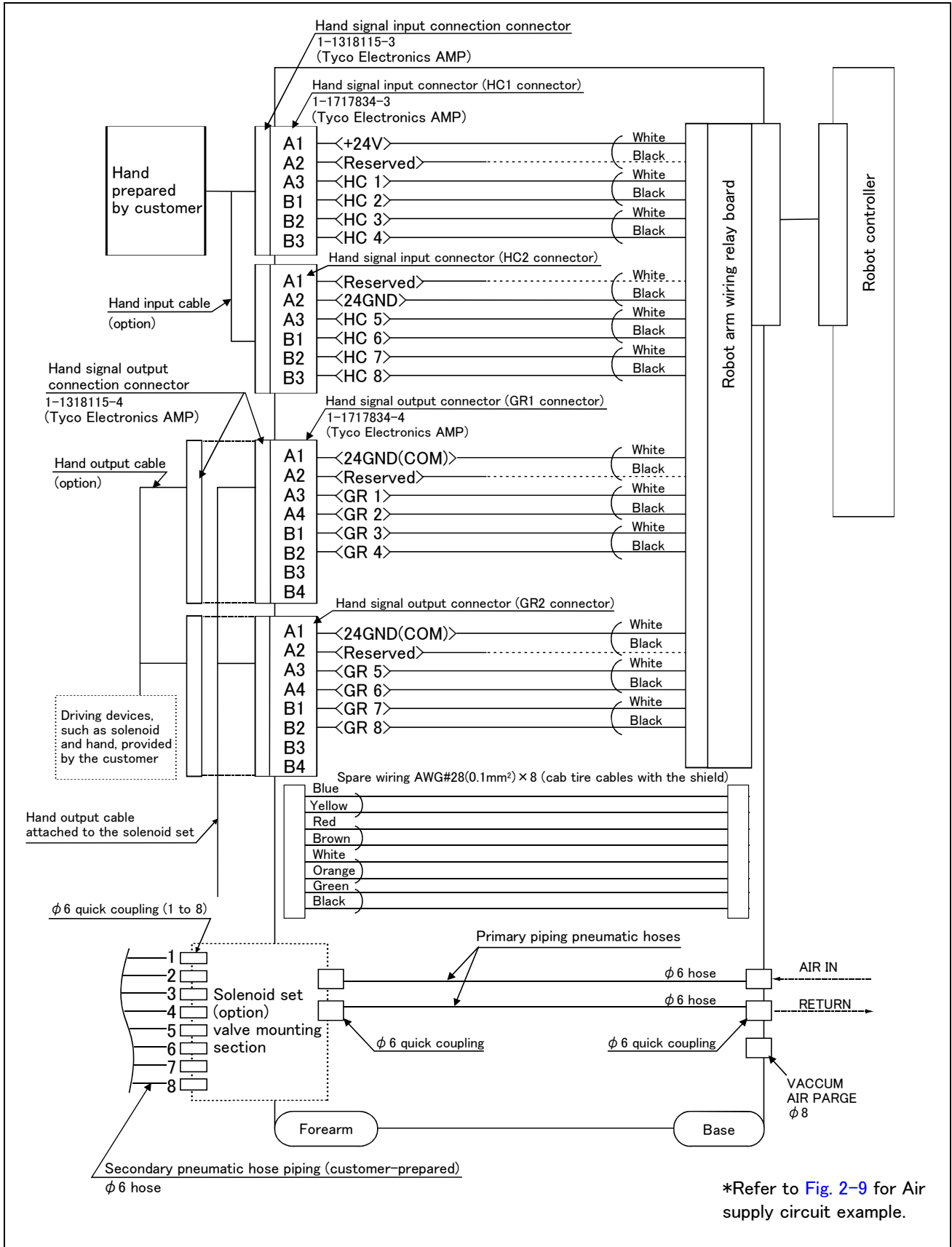

Fig.2-8 : Wiring and piping system diagram for hand and example the solenoid valve installation(Source type)

2.5.7 Electrical specifications of hand input/output

Table 2-9 : Electrical specifications of input circuit

Item	Specifications	Internal circuit	
Type	DC input	<div style="display: flex; flex-direction: column; align-items: center;"> <div style="text-align: center;"> <p><Sink type></p> </div> <div style="text-align: center; margin-top: 20px;"> <p><Source type></p> </div> <p style="margin-top: 20px;">* HCn = HC1 ~ HC8</p> </div>	
No. of input points	8		
Insulation method	Photo-coupler insulation		
Rated input voltage	12VDC/24VDC		
Rated input current	Approx. 3mA/approx. 7mA		
Working voltage range	DC10.2 to 26.4V(ripple rate within 5%)		
ON voltage/ON current	8VDC or more/2mA or more		
OFF voltage/OFF current	4VDC or less/1mA or less		
Input resistance	Approx. 3.3kΩ		
Response time	OFF-ON		10ms or less(DC24V)
	ON-OFF		10ms or less(DC24V)

Table 2-10 : Electrical specifications of output circuit

Item	Specification	Internal circuit	
Type	Transistor output	<div style="display: flex; flex-direction: column; align-items: center;"> <div style="text-align: center;"> <p><Sink type></p> </div> <div style="text-align: center; margin-top: 20px;"> <p><Source type></p> </div> <p style="margin-top: 20px;">* GRn = GR1 ~ GR8</p> </div>	
No. of output points	8		
Insulation method	Photo coupler insulation		
Rated load voltage	DC24V		
Rated load voltage range	DC21.6 to 26.4VDC		
Max. current load	0.1A/ 1 point (100%)		
Current leak with power OFF	0.1mA or less		
Maximum voltage drop with power ON	DC0.9V(TYP.)		
Response time	OFF-ON		2ms or less (hardware response time)
	ON-OFF		2 ms or less (resistance load) (hardware response time)
Fuse rating	1.0A (each one common) Cannot be exchanged		

Note) An optional pneumatic hand interface (2A-RZ365/2A-RZ375) is required to use hand output.

2.5.8 Air supply circuit example for the hand

Fig. 2-9 shows an example of pneumatic supply circuitry for the hand.

- (1) Place diodes parallel to the solenoid coil.
- (2) When the factory pneumatic pressure drops, as a result of the hand clamp strength weakening, there can be damage to the work. To prevent it, install a pressure switch to the source of the air as shown in Fig. 2-9 and use the circuit described so that the robot stops when pressure drops. Use a hand with a spring-pressure clamp, or a mechanical lock-type hand, that can be used in cases where the pressure switch becomes damaged.
- (3) The optional hand and solenoid valve are of an oilless type. If they are used, don't use any lubricator.
- (4) Supply clean air to the vacuum generation valve when you use clean type robot.
- (5) If the air supply temperature (primary piping) used for the tool etc. is lower than ambient air temperature, the dew condensation may occur on the coupling or the hose surface.

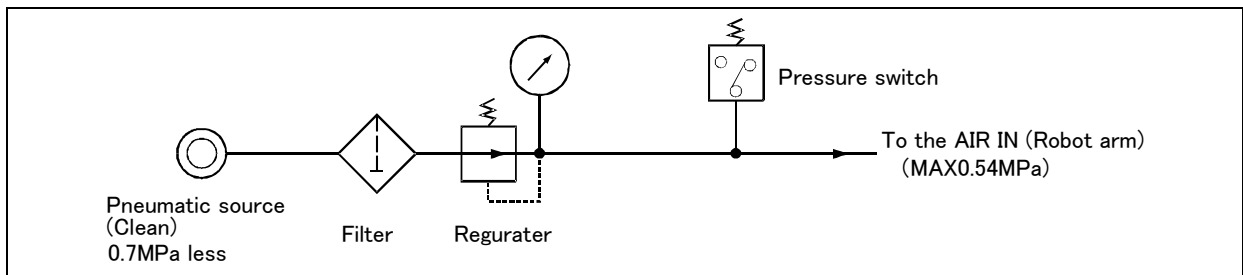

Fig.2-9 : Air supply circuit example for the hand

2.6 Shipping special specifications, options, and maintenance parts

2.6.1 Shipping special specifications

■ What are shipping special specifications?

Shipping special specifications are changed before shipping from the factory. Consequently, it is necessary to confirm the delivery date by the customer.

To make changes to the specifications after shipment, service work must be performed at the work site or the robot must be returned for service.

■ How to order

(1) Confirm beforehand when the factory special specifications can be shipped, because they may not be immediately available.

(2) Specified method ····· Specify the part name, model, and robot model type.

(1) Machine cable

■ Order type: ● Fixed type 1S-02CBL-1 (2m)

■ Outline

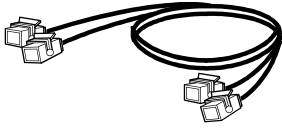

This cable is exchanged for the machine cable (5 m for fixed type) that was supplied as standard to shorten the distance between the controller and the robot arm.

■ Configuration

Table 2-11 : Configuration equipments and types

Part name		Type	Qty.	Mass(kg) ^{Note1)}	Remarks
Fixed	Set of signal and power cables	1S-02CBL-1	1 set	3.4	2m
	Motor signal cable	BKO-FA0741H02	(1 cable)	-	
	Motor power cable	BKO-FA0739H02	(1 cable)	-	

Note1) Mass indicates one set.

Note) Standard 5 m (for fixed type) is not attached.

[Caution] Orders made after purchasing a robot are treated as purchases of optional equipment. In this case, the machine cable (5 m for fixed type) that was supplied as standard is not reclaimed.

2.7 Options

■ What are options?

There are a variety of options for the robot designed to make the setting up process easier for customer needs. customer installation is required for the options. Options come in two types: "set options" and "single options".

1. Set optionsA combination of single options and parts that together, from a set for serving some purpose.
2. Single optionsThat are configured from the fewest number of required units of a part. Please choose customer's purpose additionally.

(1) Machine cable extension

- Order type : ● Fixed type 1S- □□ CBL-01
- Flexed type 1S- □□ LCBL-01 Note) The numbers in the boxes □□ refer the length.

■ Outline

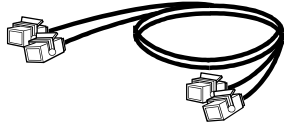

The distance between the robot controller and the robot arm is extensible by this option. This cable is extended to the machine cable attached as standard. (5m for fix type)

A fixed type and flexible type are available. The fix and flexible types are both configured of the motor signal cable and motor power cable.

■ Configuration

Table 2-12 : Configuration equipments and types

Part name	Type ^{Note1)}	Qty.		Mass(kg) Note2)	Remarks
		Fixed	Flexed		
Fixed	Set of signal and power cables	1S- □□ CBL-01	1 set	-	6.7(5m) 12(10m) 17(15m) 5m, 10m, or 15m each
	Motor signal cable	1S- □□ CBL(S)-01	(1 cable)	-	
	Motor power cable	1S- □□ CBL(P)-01	(1 cable)	-	
Flexed	Set of signal and power cables	1S- □□ LCBL-01	-	1 set	7(5m) 13(10m) 17(15m) 5m, 10m, or 15m each
	Motor signal cable	1S- □□ LCBL(S)-01	-	(1 cable)	
	Motor power cable	1S- □□ LCBL(P)-01	-	(1 cable)	
Nylon clamp	NK-14N	-	2 pcs.	-	for motor signal cable
Nylon clamp	NK-18N	-	2 pcs.	-	for motor power cable
Silicon rubber		-	4 pcs.	-	

Note1) The numbers in the boxes □□ refer the length.

Note2) Mass indicates one set.

■ Specifications

The specifications for the fixed type cables are the same as those for standard cables.

Shows usage conditions for flexed type cables in [Table 2-13](#).

Table 2-13 : Conditions for the flexed type cables

Item	Specifications	
Minimum flexed radius	100R or more	
Cableveyor, etc., occupation rate	50% or less	
Maximum movement speed	2000mm/s or less	
Guidance of life count	7.5 million times	
Environmental proof	Oil-proof specification sheath (for silicon grease, cable sliding lubricant type)	
Cable configuration	Motor signal cable	$\phi 6 \times 5$, $\phi 8.5 \times 1$ and $\phi 1.7 \times 1$
	Motor power cable	$\phi 7.5 \times 2$ and $\phi 6 \times 8$

[Caution] The guidance of life count may greatly differ according to the usage state (items related to [Table 2-13](#) and to the amount of silicon grease applied in the cable conduit.

[Caution] This option can be installed on clean-type, but its cleanliness is not under warranty.

■ Cable configuration

The configuration of the flexible cable is shown in Table 2-14. Refer to this table when selecting the cable bare.

Table 2-14 : Cable configuration

Item	Motor signal cable 1S- □ □ LCBL(S)-01			Motor power cable 1D- □ □ LCBL(P)-01	
	AWG#24(0.2mm ²)-4P	AWG#24(0.2mm ²)-7P	AWG#18(0.75mm ²)	AWG#17(1.25mm ²)-4C	AWG#19(0.75mm ²)-4C
No. of cores	Approx. φ 6mm	Approx. φ 8.5mm	Approx. φ 1.7mm	Approx. φ 7.5mm	Approx. φ 6mm
No. of cables used	5 cables	1 cable	1 cable	2 cable	8 cable
No. in total	7 cables			10 cables	

Note) The square in the cable name indicates the cable length.

■ Fixing the flexible cable

- (1) Connect the connector to the robot arm .
- (2) Wind the silicon rubber around the cable at a position 300 to 400 mm from the side of robot arm and extension section as shown in Fig. 2-10, and fix with the nylon clamp to protect the cable from external stress.

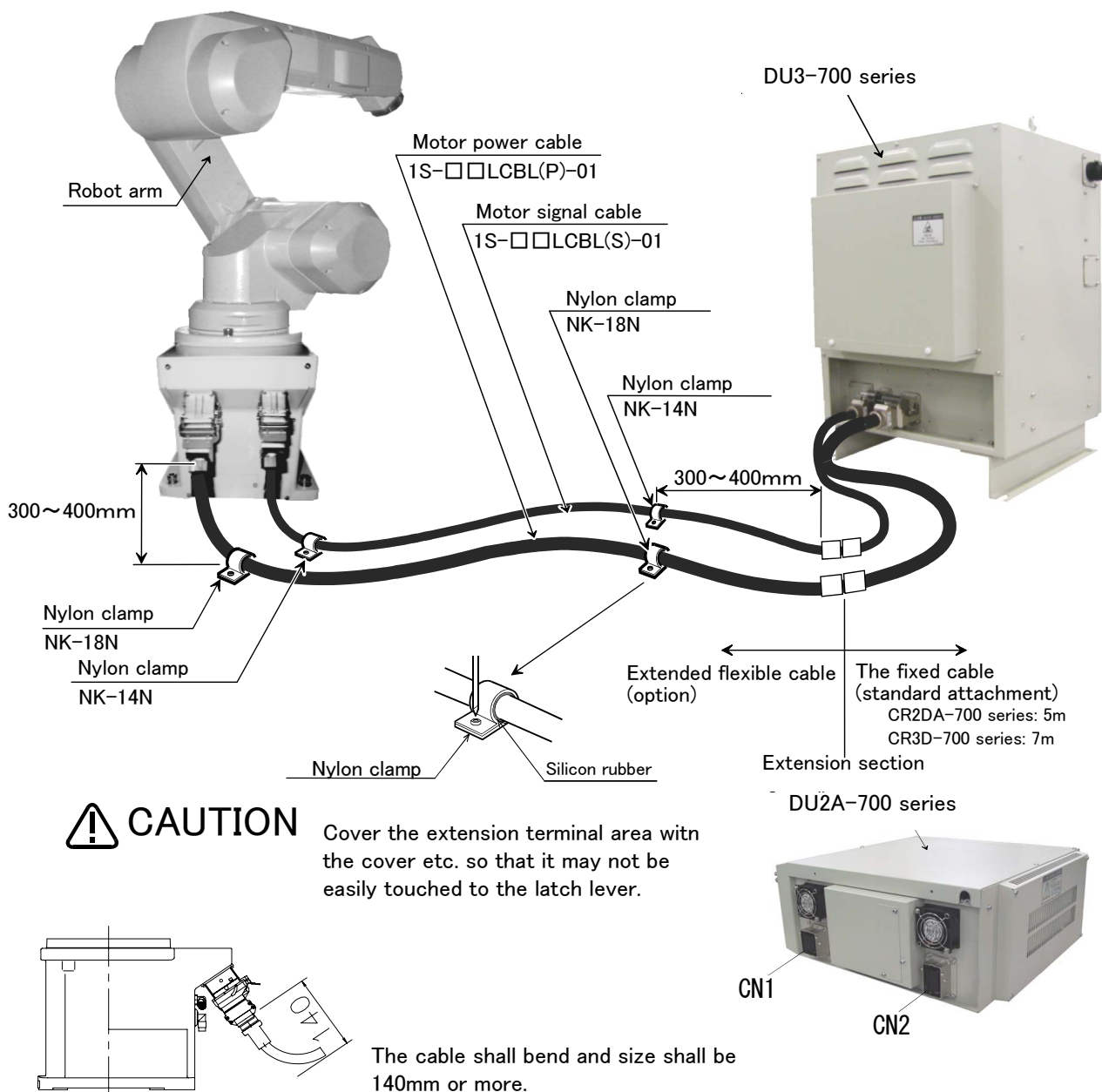

Fig.2-10 : Fixing the flexible cable

(2) Changing the operating range

■ Order type: J1 axis.....1S-DH -02

■ Outline



The operating range of J1 axis is limited by the robot arm's mechanical stopper and the controller parameters.
If the axis could interfere with the peripheral devices, etc., and the operating range need to be limited, use this.

■ Configuration

Table 2-15 : Configuration devices

Part name	Type	Qty.	Mass(kg)	Remarks
Stopper for changing the operating range of J1	1S-DH-02	2 pcs.	0.1	Hexagon socket bolt: M12 x 20 plating (strength classification 10.9)

■ Specifications

Table 2-16 : Specifications

Axis		Standard	Changeable angle
J1	+ side	+170 degree	One point from +135° , +90° , +45°
	- side	-170 degree	One point from -135° , -90° , -45°

- (1) The changeable angle shown in [Table 2-16](#) indicates the operation range by the software.
The limit by the mechanical stopper is positioned 1 degrees outward from that angle, so take care when designing the layout.
- (2) The changeable angle can be set independently on the + side and - side.
- (3) The operating range is changed with robot arm settings and parameter settings. Refer to the separate "Instruction Manual/ROBOT ARM SETUP & MAINTENANCE" or "Instruction Manual/Detailed Explanation of Functions and Operations" for details.

(3) Solenoid valve set

- Order type: One set: 1S-VD01-02(Sink type)/1S-VD01E-02(Source type)
Two sets: 1S-VD02-02(Sink type)/1S-VD02E-02(Source type)
Three sets: 1S-VD03-02(Sink type)/1S-VD03E-02(Source type)
Four sets: 1S-VD04-02(Sink type)/1S-VD04E-02(Source type)

■ Outline

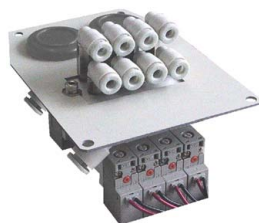

The solenoid valve set is an option that is used for controlling toolings when various toolings, such as the hand, are installed at the end of the arm. All have double solenoid specification, and either one or two or three sets can be selected. This solenoid valve set has a hand output cable attached to the solenoid valve. Also, for easy installation of this electromagnetic set onto the robot, it comes equipped with a manifold, couplings, silencers, among other things.

When using the robot arm's hand output signal, the pneumatic hand interface option*1) must be installed on the separate controller.

■ Configuration

Table 2-17 : Configuration equipment

Part name	Type	Q'ty				Mass(kg) Note1)	Remark
		One set	Two sets	Three sets	Four sets		
Solenoid valve set (1 set)	1S-VD01-02/ 1S-VD01E-02	1 pc.	—	—	—	0.3	M4x8 four screws (installation screws). 1S-VD01-02/VD02-02/VD03-02/ VD04-02 are the sink type. 1S-VD01E-02/VD02E-02/VD03E-02/ VD04E-02 are the source type.
Solenoid valve set (2 sets)	1S-VD02-02/ 1S-VD02E-02	—	1 pc.	—	—	0.4	
Solenoid valve set (3 sets)	1S-VD03-02/ 1S-VD03E-02	—	—	1 pc.	—	0.4	
Solenoid valve set (4 sets)	1S-VD04-02/ 1S-VD04E-02	—	—	—	1 pc.	0.5	

Note1) Mass indicates one set.

■ Specifications

Table 2-18 : Valve specifications

Item	Specifications
Number of positions	2
Port	5 Note1)
Valve function	Double solenoid
Operating fluid	Clean air Note2)
Operating method	Internal pilot method
Effective sectional area (CV value)	1.1mm ² (0.06)
Oiling	Unnecessary
Operating pressure range	0.1 ~ 0.7MPa
Response time	22msec or less (at 0.5 MPa)
Max. operating frequency	5Hz
Ambient temperature	-10 to 50 °C (However, there must be no condensation.)

Note1) Couplings of unused solenoid valves must be blocked with plugs. If they are not blocked, supplied air will blow out from the couplings, lowering the air pressure of the solenoid valves being used and making them nonfunctional (recommended plugs: KQ2P-04 plugs made by SMC).

Note2)



CAUTION The air to be provided must be clean, i.e., filtered with a mist separator or air filter. Failing to do so may lead to malfunctions.

Table 2-19 : Solenoid specifications

Item	Specifications
Coil rated voltage	DC24V ±10%
Power consumption	0.55W
Voltage protection circuit with power surge protection	Diode

1) Use "2A-RZ365" for "1S-VD0-02 (sink type) " and use "2A-RZ375" for "1S-VD0*-02E (source type) "

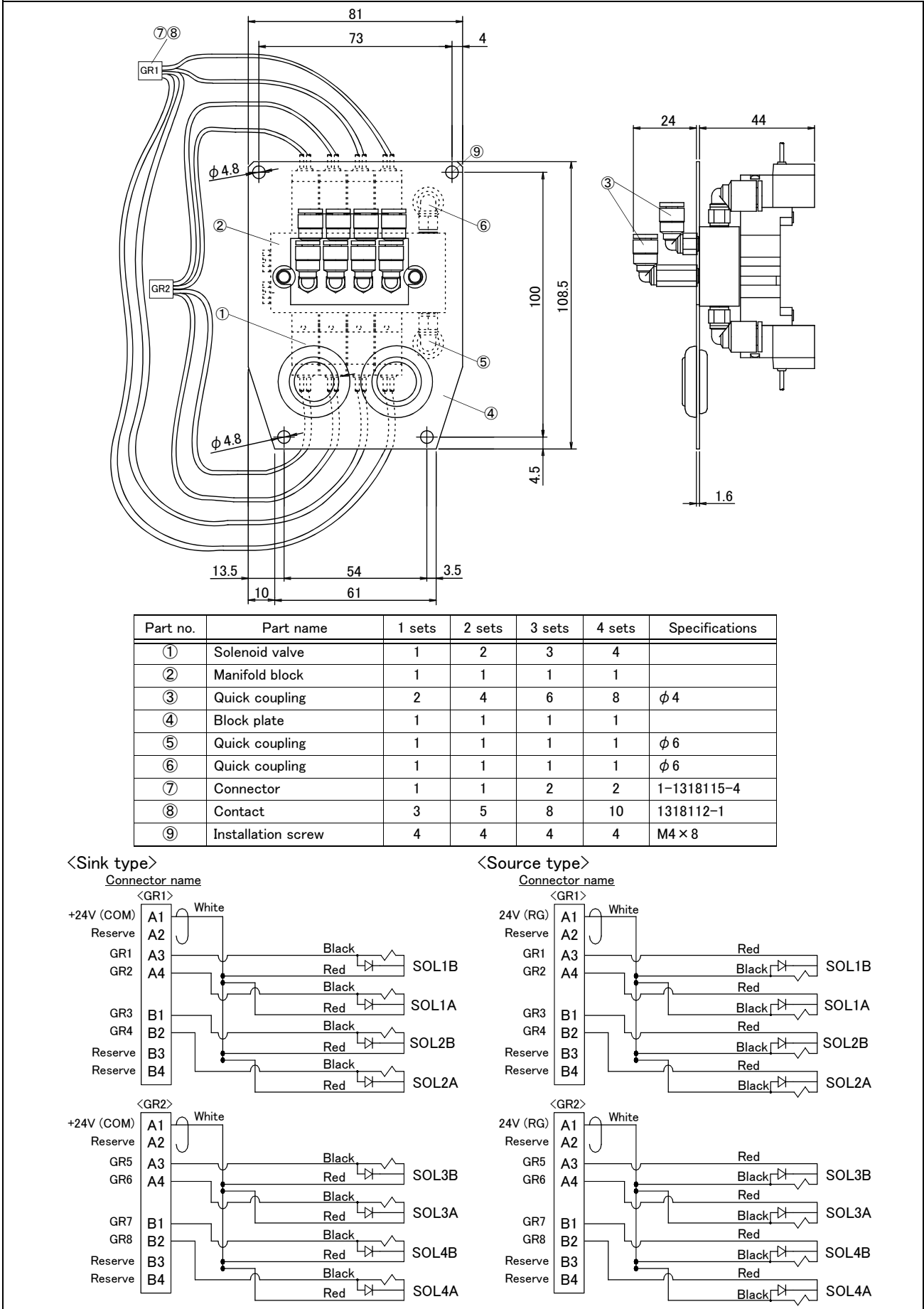
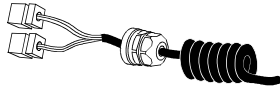

Fig.2-11 : Outline dimensional drawing

(4) Hand input cable

■ Order type: 1S-HC25C-01

■ Outline



The hand input cable is used for customer-designed pneumatic hands. It is necessary to use this to receive the hand's open/close confirmation signals and grasping confirmation signals, at the controller. One end of the cable connects to the connector for hand input signals, which is in the wrist section of the hand. The other end of the cable connects to the sensor inside the hand customer designed.

■ Configuration

Table 2-20 : Configuration equipment

Part name	Type	Qty.	Mass(kg) ^{Note1)}	Remarks
Hand input cable	1S-HC25C-01	1 cable	0.2	

Note1) Mass indicates one set.

■ Specifications

Table 2-21 : Specifications

Item	Specifications	Remarks
Size x cable core	AWG#24 (0.2mm ²) × 12	One-sided connector, one-sided cable bridging
Total length	800mm (Including the curl section, which is 300mm long)	

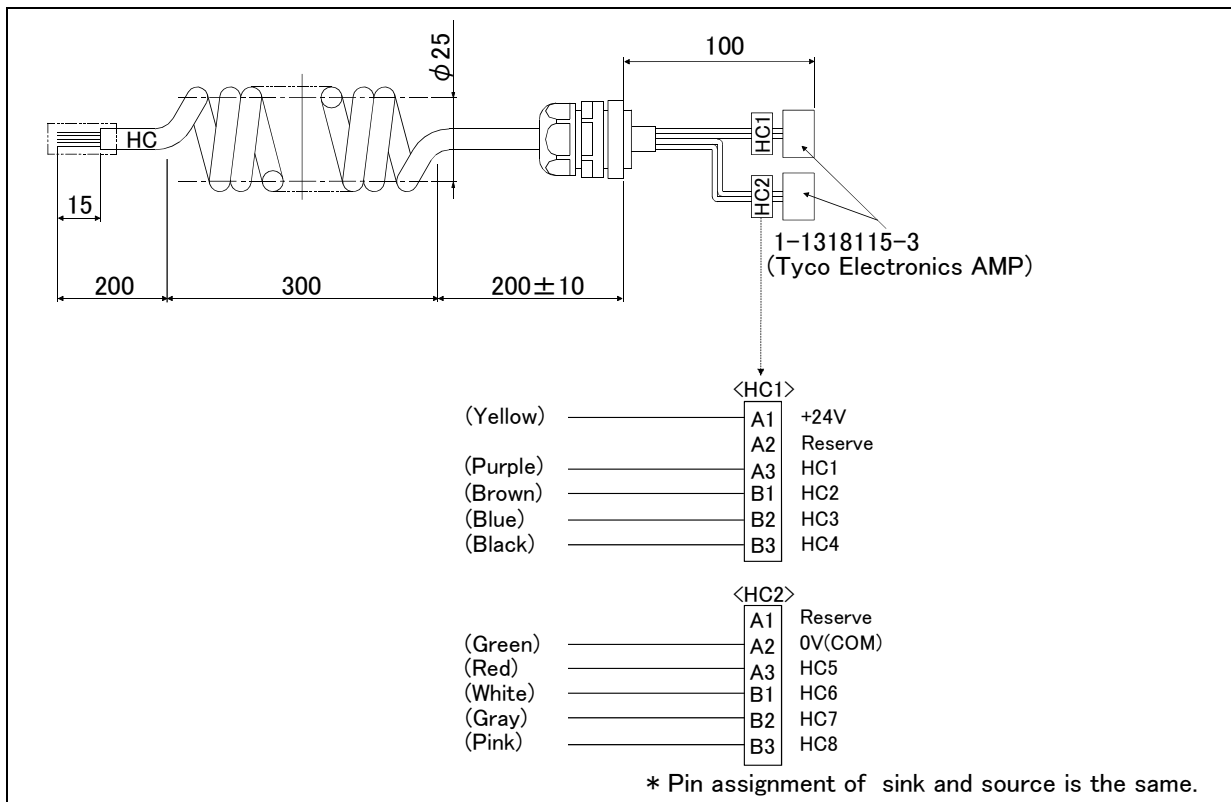

Fig.2-12 : Outside dimensional drawing and pin assignment

[Caution] This option can be installed on clean-type, but its cleanliness is not under warranty.

(5) Hand output cable

■ Order type: 1S-GR35S-01

■ Outline

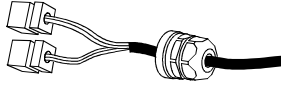

The hand output cable (solenoid valve connection cable) is an option that is used when an solenoid valve other than one of the solenoid valve set options, is used. One end of the cable has a connector that connects to the input terminal inside the robot. The other end of the cable is connected.

■ Configuration

Table 2-22 : Configuration equipment

Part name	Type	Qty.	Mass(kg) ^{Note1)}	Remarks
Hand output cable	1S-GR35S-01	1 cable	0.1	

Note1) Mass indicates one set.

■ Specifications

Table 2-23 : Specifications

Item	Specifications	Remarks
Size x Cable core	AWG#24(0.2mm ²) x 12 cores	One side connector and one side cable connection
Total length	400mm	

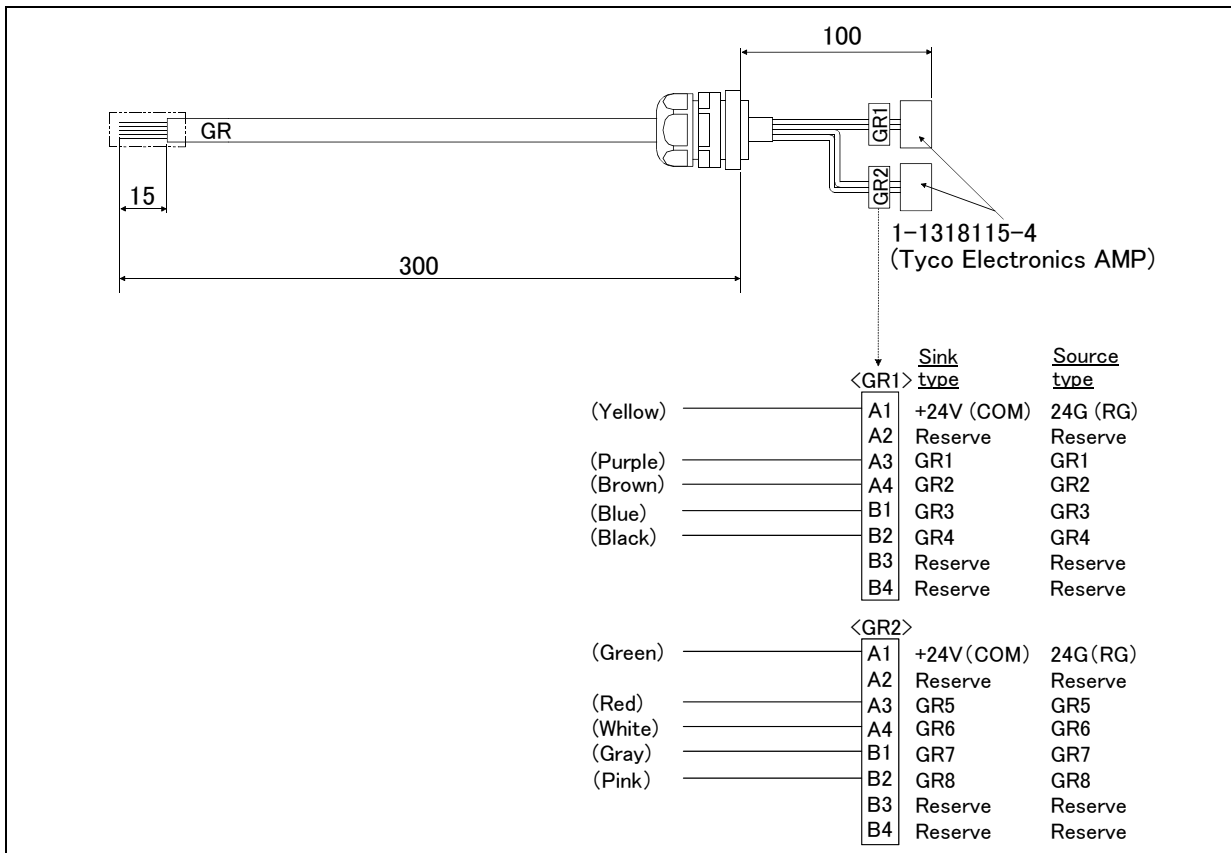

Fig.2-13 : Outline dimensional drawing and pin assignment

[Cautions] When you install this optional one in the protection specification type, please seal the fixing section of the robot with silicon rubber by the customer.

[Caution] This option can be installed on clean-type, but its cleanliness is not under warranty.

(6) Hand curl tube

- Order type: One set :1E-ST0402C
- Two sets :1E-ST0404C
- Three sets :1E-ST0406C
- Four sets :1E-ST0408C

■ Outline

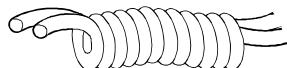

The hand curl tube is a curl tube for the pneumatic hand.

■ Configuration

Table 2-24 : Configuration equipment

Part name	Type	Qty.	Mass(kg) ^{Note1)}	Remarks
Hans curl tube (One set: 2 pcs.)	1E-ST0402C	1 pc.	0.1	Φ4 tube, 2pcs.
Hans curl tube (Two set: 4 pcs.)	1E-ST0404C	1 pc.	0.1	Φ4 tube, 4pcs.
Hans curl tube (Three set: 6 pcs.)	1E-ST0406C	1 pc.	0.1	Φ4 tube, 6pcs.
Hans curl tube (Four set: 8 pcs.)	1E-ST0408C	1 pc.	0.1	Φ4 tube, 8pcs.

Note1) Mass indicates one set.

■ Specifications

Table 2-25 : Specifications

Item	Specifications
Material	Urethane
Size	Outside diameter: $\phi 4$ x Inside diameter: $\phi 2.5$

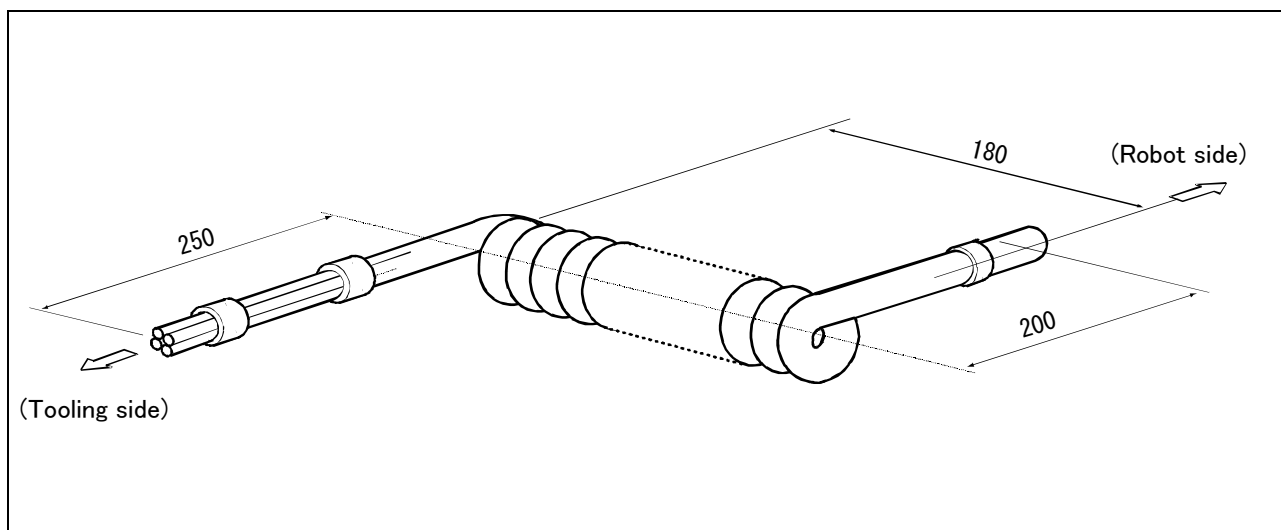

Fig.2-14 : Outline dimensional drawing

[Caution] This option can be installed on clean-type, but its cleanliness is not under warranty.

2.8 About Overhaul

Robots which have been in operation for an extended period of time can suffer from wear and other forms of deterioration. In regard to such robots, we define overhaul as an operation to replace parts running out of specified service life or other parts which have been damaged, so that the robots may be put back in shape for continued use. Overhaul interval for robots presumably varies with their operating conditions and thus with the degree of the equipment's wear and loss of performance. As a rule of thumb, however, it is recommended that overhaul be carried out before the total amount of servo-on time reaches the predetermined levels (24,000 hours for the robot body and 36,000 hours for the controller). (See Fig. 2-15.) For specific information about parts to be replaced and timing of overhaul, contact your local service representative.

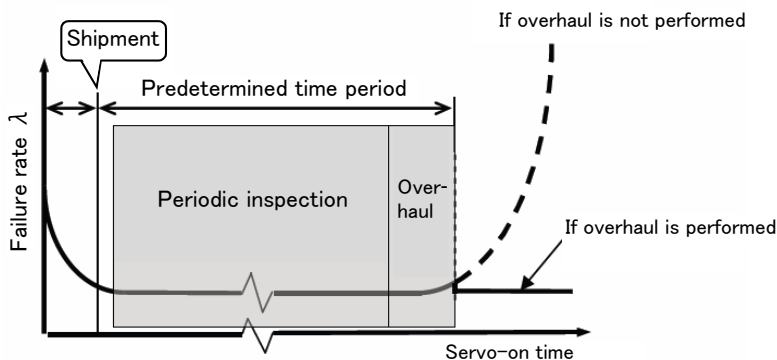

Fig.2-15 : Periodic inspection/overhaul periods

2.9 Maintenance parts

The consumable parts used in the robot arm are shown in Table 2-26. Purchase these parts from the designated maker or dealer when required. Some Mitsubishi-designated parts differ from the maker's standard parts. Thus, confirm the part name, robot arm and controller serial No. and purchase the parts from the dealer.

Table 2-26 : Consumable part list

No.	Part name	Type ^{Note1)}	Usage place	Qty.	Supplier
1	Grease	SK-1A	Reduction gears of each axis	As needed	Mitsubishi Electric
2	Lithium battery	A6BAT	In the battery cover	5 pcs.	

Note1) Confirm the robot arm serial No., and contact the dealer or service branch of Mitsubishi Electric Co., for the type.

Table 2-27 : Consumable part (packing) list

No.	part name	Details of configuration		Usage place		
		Packing name	Qty.	Cover name	Qty.	Sticking side
RV-6SQ/6SQC						
1	Shoulder cover packing Part Code : K07S24317151	Shoulder cover packing A	2	Shoulder cover	1	Cover side
		Shoulder cover packing B	2		1	Cover side
2	Elbow cover packing Part Code : K07S24344901	Elbow cover packing	1	Elbow cover A	1	Cover side
3	No.2 arm cover packing Part Code : K07S24342001	No.2 arm cover packing	1	No. 2 arm cover A	1	Cover side
				No. 2 arm cover B	1	Cover side
4	No.1arm cover packing Part Code : K07S24317251	No.1arm cover packing A	1	No. 1 arm cover	1	Robot arm side
		No.1arm cover packing B	1		1	Robot arm side
		No.1arm cover packing C	2		2	Robot arm side
5	Wrist cover packing Part Code : K07S24401602	Wrist cover packing	1	Wrist cover	1	Robot arm side
6	No.2 arm cover C packing Part Code : K07S24401502	No.2 arm cover C packing	1	No. 2 arm cover C	1	Robot arm side
7	Base Packing Part Code : K07S24345651	Conbox cover packing A	1	CONBOX cover	1	Robot arm side
		Conbox cover packing B	1		1	Robot arm side
		Base bottom cover packing A	1	Bottom plate	1	Robot arm side
		Base bottom cover packing B	1		1	Robot arm side
8	Battery bracket packing Part Code : K07S24412401	Battery bracket packing	1	Battery cover	1	Cover side
9	Shoulder cover B packing Part Code : K07S24319401	Shoulder cover B packing	1	Shoulder cover B	1	Robot arm side
RV-6SQL/6SQCL						
10	Shoulder cover packing Part Code : K07S24317151	Shoulder cover packing A	2	Shoulder cover	1	Cover side
		Shoulder cover packing B	2		1	Cover side
11	Elbow cover packing Part Code : K07S24344901	Elbow cover packing	1	Elbow cover A	1	Cover side
12	No.2 arm cover packing Part Code : K07S24342001	No.2 arm cover packing	1	No. 2 arm cover A	1	Cover side
				No. 2 arm cover B	1	Cover side
13	No.1arm L cover packing Part Code : K07S24322451	No.1 arm L cover packing A	1	No. 1 arm cover	1	Robot arm side
		No.1 arm L cover packing B	1		1	Robot arm side
		No.1 arm L cover packing C	2		2	Robot arm side
14	Wrist cover packing Part Code : K07S24401602	Wrist cover packing	1	Wrist cover	1	Robot arm side
15	No.2 arm cover C packing Part Code : K07S24401502	No.2 arm cover C packing	1	No. 2 arm cover C	1	Robot arm side
16	Base Packing Part Code : K07S24345651	Conbox cover packing A	1	CONBOX cover	1	Robot arm side
		Conbox cover packing B	1		1	Robot arm side
		Base bottom cover packing A	1	Bottom plate	1	Robot arm side
		Base bottom cover packing B	1		1	Robot arm side
17	Battery bracket packing Part Code : K07S24412401	Battery bracket packing	1	Battery cover	1	Cover side
18	Shoulder cover B packing Part Code : K07S24319401	Shoulder cover B packing	1	Shoulder cover B	1	Robot arm side
19	Joint arm cover U packing Part Code : K07S24430301	Joint arm cover U packing	1	Joint arm cover U	1	Robot arm side
20	Joint arm cover R packing Part Code : K07S24430401	Joint arm cover R packing	1	Joint arm cover R	1	Robot arm side

3 Controller

3.1 Standard specifications

3.1.1 Standard specifications

Table 3-1 : Standard specifications of controller

Item		Unit	Specification	Remarks
Type			CR2QA-711 or CR3Q-711M	Note1) RV-6SQ/6SQL/6SQC/6SQLC: CR2QA-711 RV-6SQ-SM/6SQL-SM: CR3Q-711M
Number of control axis			Simultaneously 6(Maximum)	
CPU			64 bit RISC / DSP	
Memory capacity	Programmed positions and No. of steps	point step	13,000 26,000	
	Number of programs		256	
Robot language			MELFA-BASIC V or MELFA-BASIC V ^{Note2)}	
Teaching method			Pose teaching method, MDI method ^{Note3)}	
External input and output	input and output	point	Input 0 point/Output 0 point	Multi-CPU share device Input 8192/Output 8192 (Max.)
	Dedicated input/output		Assign to the multi-CPU share device.	
	Special stop input	point	1	
	Hand open/close input/output	point	Input 8 point/Output 0 point	Up to 8 output points can be added as an option ^{Note4)}
	Emergency stop input	point	1	Dual line, normal close
	Door switch input	point	1	Dual line, normal close
	Enabling device input	point	1	Dual line, normal close
	Mode output	point	1	Dual line
	Robot error output	point	1	Dual line
Additional axis synchronization	point	1	Dual line	
Interface	RS-422	port	1	Only for the teaching pendant
	Ethernet	port	1 : Only for the teaching pendant	100BASE-TX
	Hand dedicated slot	slot	1	Dedicated for pneumatic hand interface
	Additional axis interface	Channel	1	SSCNET III

Note1)The drive unit which consists of CR3Q-711M controller has the protection structure which fitted IP54.

Note2)The program of MELFA-BASIC IV can be used by MELFA-BASIC V, if program is converted by RT ToolBox2 (option).

Note3)Pose teaching method: The method to register the current position of the robot arm.

MDI method: The method to register by inputting the numerical value Immediate.

Note4)It is when an pneumatic hand interface (2A-RZ365/2A-RZ375) is installed.

Table 3-2 : Standard specifications of drive unit

Item		Unit	Specification		Remarks
Type			DU2A-711	DU3-711M	RV-6SQ/6SQL/RV-6SQC/6SQLC: DU2A-711 RV-6SQ-SM/6SQL-SM: DU3-711M
External input and output	input and output	point	0/0		Multi-CPU share device Input 8192/Output 8192 (Max.)
	Dedicated input/output		Assign to the multi-CPU share device.		
	Special stop input	point	1		
	Hand open/close input/output	point	Input 8 point/Output 0 point		Up to 8 output points can be added as an option ^{Note1)}
	Emergency stop input	point	1		Dual line, normal close
	Door switch input	point	1		Dual line, normal close
	Enabling device input	point	1		Dual line, normal close
	Mode output	point	1		Dual line
	Robot error output	point	1		Dual line
Interface	Addition axis synchronization	point	1		Dual line
	RS-422	port	1		Only for the teaching pendant
	Ethernet	port	1 : Only for the teaching pendant		100BASE-TX
Power source	Hand dedicated slot	slot	1		icated for pneumatic hand interface
	Input voltage range	V	1-phase, AC180 to 253V	3-phase, AC180 to 253V	Note2)
	Power capacity	kVA	2.0		Does not include rush current ^{Note3)} Note4)
	Power supply frequency	Hz	50 / 60		
Outline dimensions		mm	467(W) x 400(D) x 200(H)	450(W) x 440(D) x 625(H)	Does not include rush current ^{Note5)}
Mass		kg	Approx. 2.0	Approx. 6.0	
Construction			Opened type (IP20) ^{Note6)}	Self-contained floor type, Closed type(IP54) ^{Note7)}	
Operating temperature range		°C	0 ~ 40		
Ambient humidity		%RH	45 ~ 85		Without dew drops
Grounding		Ω	100 or less		D class grounding earth ^{Note8)}
Paint color			Light gray		Munsell 0.08GY7.64/0.81

Note1) It is when an pneumatic hand interface (2A-RZ365/2A-RZ375) is installed.

Note2) Please use the controller with an input power supply voltage fluctuation rate of 10% or less.

Note3)The power capacity is the rating value for normal operation. The power capacity does not include the rush current when the power is turned ON. The power capacity is a guideline and the actual operation is affected by the input power voltage. The short circuit breaker should use the following.

*Operate by the current leakage under the commercial frequency domain (50-60Hz).

If sensitive to the high frequency ingredient, it will become the cause in which below the maximum leak current value carries out the trip.

Note4)If the earth leakage breaker is installed in the primary side power supply circuit of the drive unit, please select the earth leakage breaker of the specification of the amperage rating 20A and 10mA of sensed current. (The leak current of the controller is set to about 7.5mA)

Note5)Becomes 615(H) at the caster specification. (DU3-711M only)

Note6)The DU2-700 series drive unit is a general environment specification. For use in an oil-mist environment or in an environment with excess dust, use the drive unit of protection specification.

Note7)The DU3-700M series drive unit exchanges heat using the internal air circulation self-cooling method. Furthermore, the rear side sucks in the outside air and the top and bottom sections of the rear side discharges the inside air. And, has the protection structure which fitted IP54.

Note8)The robot must be grounded by the customer.

Table 3-3 : Robot CPU unit standard specification

Item		Unit	Specification	Remarks
Type			Q172DRCPU	
Interface	Addition axis synchronization	port	1	
Power source	Power capacity (DC5V)	A	1 . 2 5	
Outline dimensions		mm	2 7 . 4 (W) x 9 8 (D) x 1 1 9 . 3 (H)	
Mass		kg	0 . 3 3	
Operating temperature range		°C	0 ~ 5 5	
Ambient humidity		%RH	5 ~ 9 5	Without dew drops

3.1.2 Protection specifications and operating supply

The standard drive unit has used the protection method which fitted IP20 (open type) of the IEC standard. Oil mist environment also prepares the drive unit (IP54 of the IEC standard (encapsulated type)) of the protection specification which can be used.

The IEC IP symbols refer only to the degree of protection between the solid and the fluids, and don't indicated that any special protection has been constructed for the prevention against oil and water.

【Information】

- The IEC IP20

It indicates the protective structure that prevents an iron ball $12^{+0.05}_0$ mm diameter, which is being pressed with the power of $3.1 \text{ kg} \pm 10\%$, from going through the opening in the outer sheath of the supplied equipment.

- The IEC IP54

The IEC IP54 standard refers to protection structure designed to prevent any harmful effects by fresh water scattering vertically onto the testing equipment in a radius of 180 degrees from a distance of 300 to 500 mm, with 10 ± 0.5 liters of water every minute, at a water pressure of 80 to 100kPa , covering the entire area of the robot with the exception of the installation section at 1 m^2 per minute, for a total of 5 minutes or more.

Refer to the section [Page 105, "6.2 Working environment"](#) for details on the working environment.

3.2 Names of each part

3.2.1 Names of each part of the drive unit

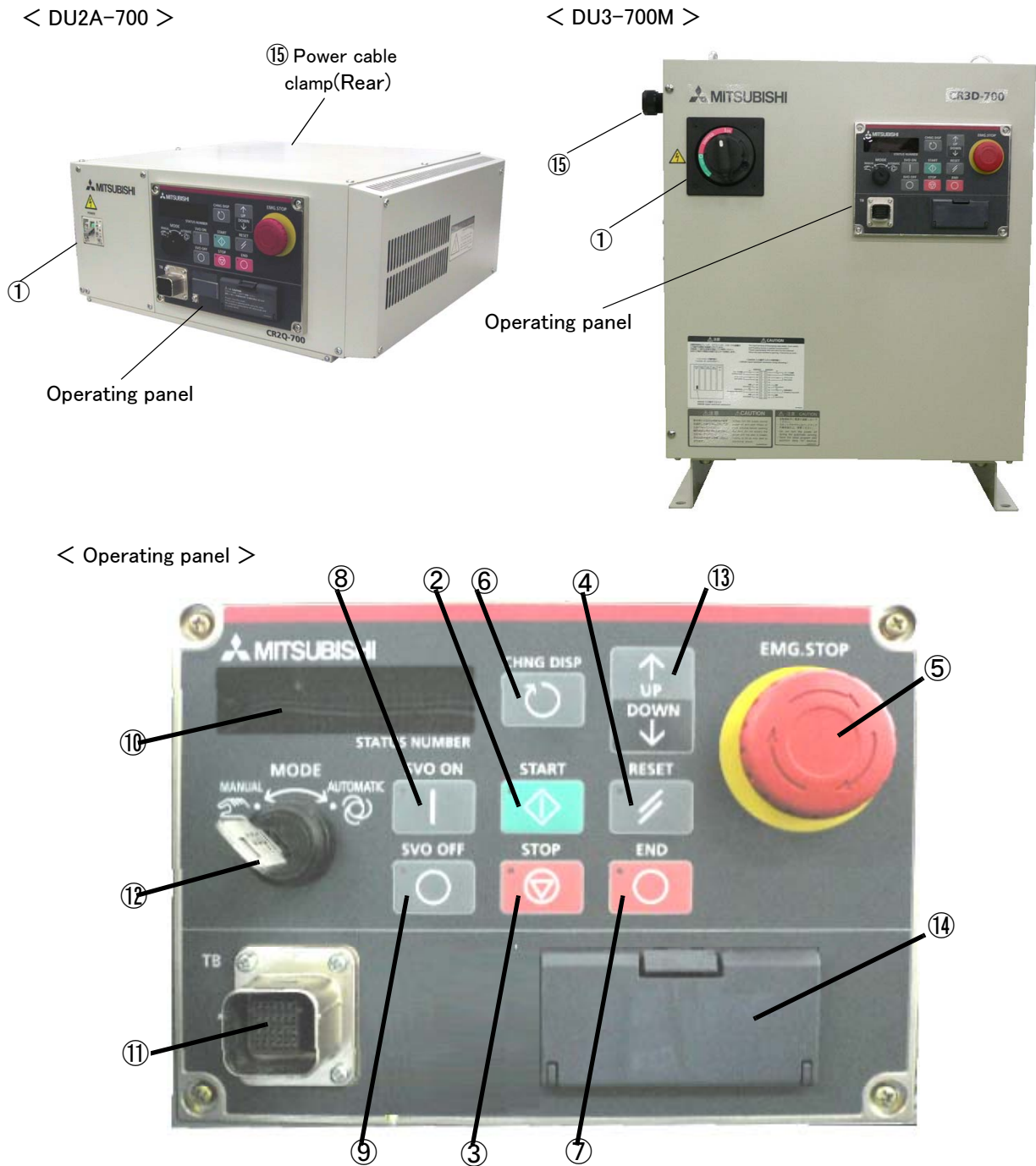

Fig.3-1 : Names of drive unit parts

- ① POWER switch.....This turns the control power ON/OFF. (With earth leakage breaker function) * 1)
- ② START button.....This executes the program and operates the robot. The program is run continuously.
- ③ STOP buttonThis stops the robot immediately. The servo does not turn OFF.
- ④ RESET button.....This resets the error. This also resets the program's halted state and resets the program.
- ⑤ Emergency stop switch.....This stops the robot in an emergency state. The servo turns OFF.
- ⑥ CHNGDISP buttonThis changes the details displayed on the display panel in the order of "Override" → "Program No." → "Line No.".
- ⑦ END button.....This stops the program being executed at the last line or END statement.
- ⑧ SVO.ON button.....This turns ON the servo power. (The servo turns ON.)
- ⑨ SVO.OFF button This turns OFF the servo power. (The servo turns OFF.)

- ⑩ STATUS NUMBER
(display panel)..... The alarm No., program No., override value (%), etc., are displayed.
- ⑪ T/B connection connector This is a dedicated connector for connecting the T/B. When not using T/B, connect the attached dummy connector.
- ⑫ MODE key switch..... This changes the robot's operation mode.
 - AUTOMATIC.....operations from the controller or external equipment are valid. Operations for which the operation mode must be at the external device or T/B are not possible. It is necessary to set the parameter for the rights of operation to connection between the operation panel and external equipment. For details, please refer to "INSTRUCTION MANUAL/Detailed explanations of functions and operations" of the separate volume.
 - MANUAL.....When the T/B is valid, only operations from the T/B are valid. Operations for which the operation mode must be at the external device or controller are not possible.
- ⑬ UP/DOWN button..... This scrolls up or down the details displayed on the "STATUS. NUMBER" display panel.
- ⑭ Interface coverUnused in this drive unit. Please use closing this cover, because of to prevent deterioration of protection performance.
- ⑮ Cable lead-in port(CR2QA-700 series)
 -Draw in the primary power cable.
 - Power cable clamp (CR3Q-700 series)
 -Fix the primary power cable.

*1)The power switch of DU2A-700/DU3-700 series can be locked by installing the padlock etc. Please prepare the padlock by the customer. Padlock specification is shown in [Page 44](#), "(1) Padlock specification"

[Note] The RS232 connection connector is not prepared by this controller. If you use it, please prepare sequencer CPU or the unit corresponding to the sequencer

(1) Padlock specification

If the robot is not used, the power switch can be locked with the padlock so that power supply ON cannot be done easily. The specification is shown in the following.

< DU2A-700 >

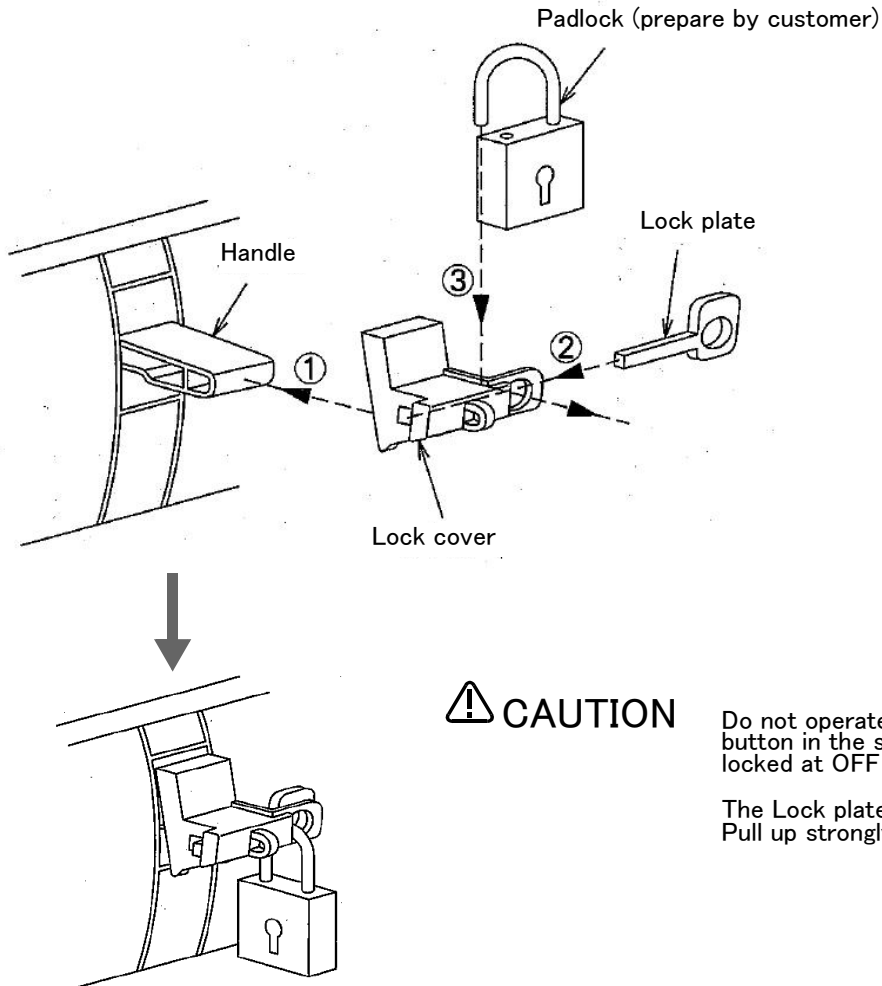

⚠ CAUTION

Do not operate the trip test by the trip button in the state of the power switch locked at OFF position.
The Lock plate is installed strongly. Pull up strongly and remove.

The lock device which can be used

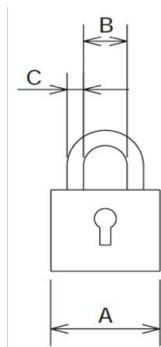

Dimension of the padlock

Dimension (mm)		
A	B	C
25	14	4mm or less

Fig.3-2 : operation lock of the power switch(DU2A-700)

< DU3-700 >

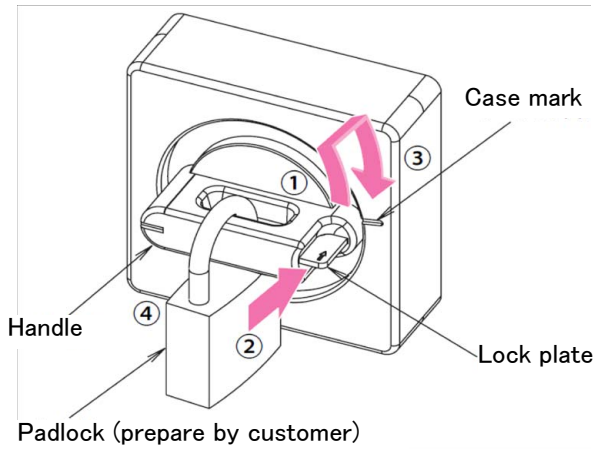

Usage of lock function

- ① Turn the handle to the reset direction until the mark of the lock plate and the case mark is in match.
- ② Push in the lock plate.
- ③ Return the handle to the OFF position, with pushing the lock plate.
- ④ Lock the handle with the padlock.

The lock device which can be used

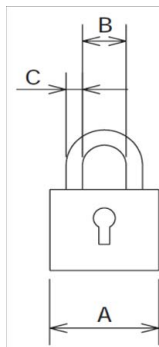

Dimension of the padlock

Dimension (mm)		
A	B	C
35(0.11)	19	5
40(0.13)	22 or 23	5.5

The maximum size of "C" which can be installed is 8mm.

Fig.3-3 : Operation lock of the power switch(DU3-700)

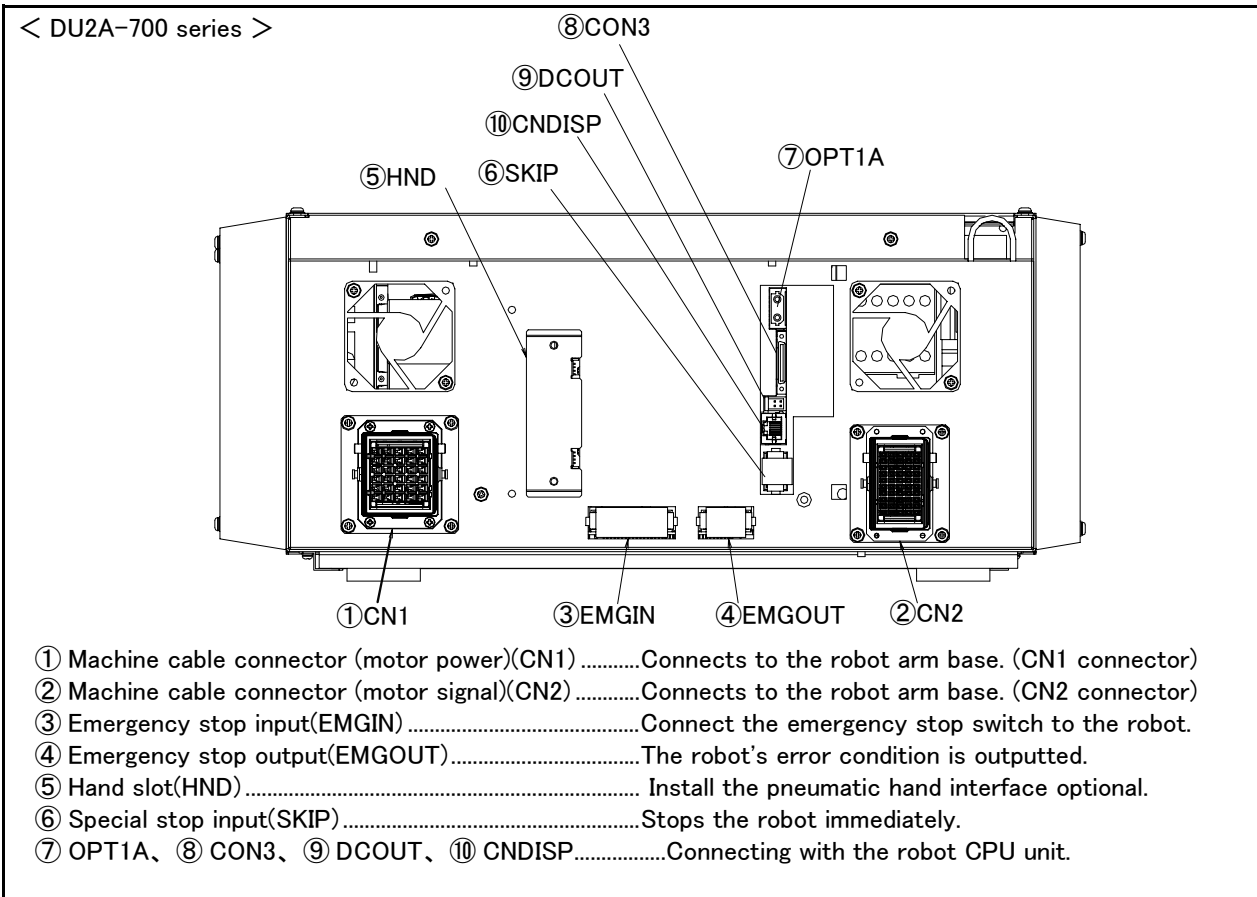

Fig.3-4 : Names of each part (Rear side DU2A-700 series)

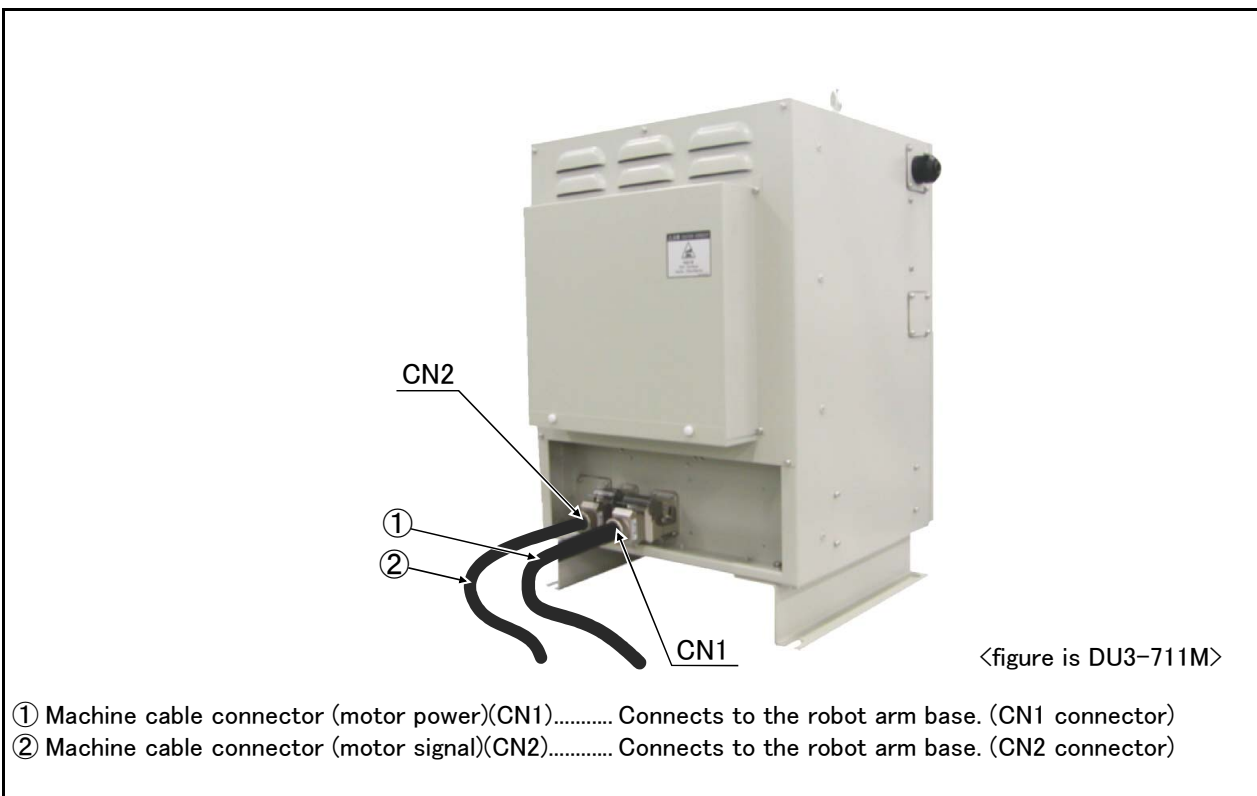

Fig.3-5 : Names of each part (Rear side DU3-700 series)

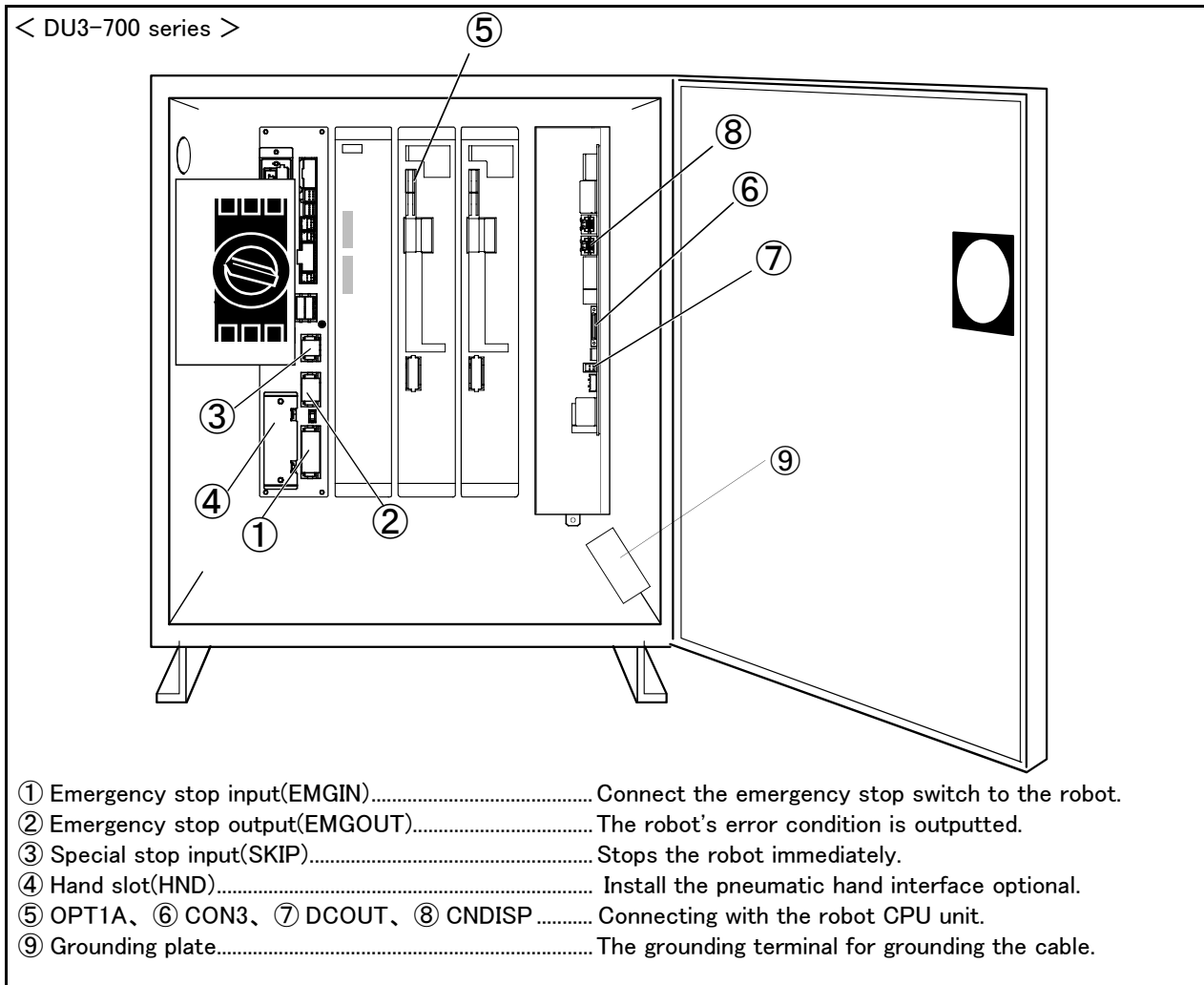

Fig.3-6 : Names of each part (Rear side DU3-700 series)

3.2.2 Names of each part of the robot CPU

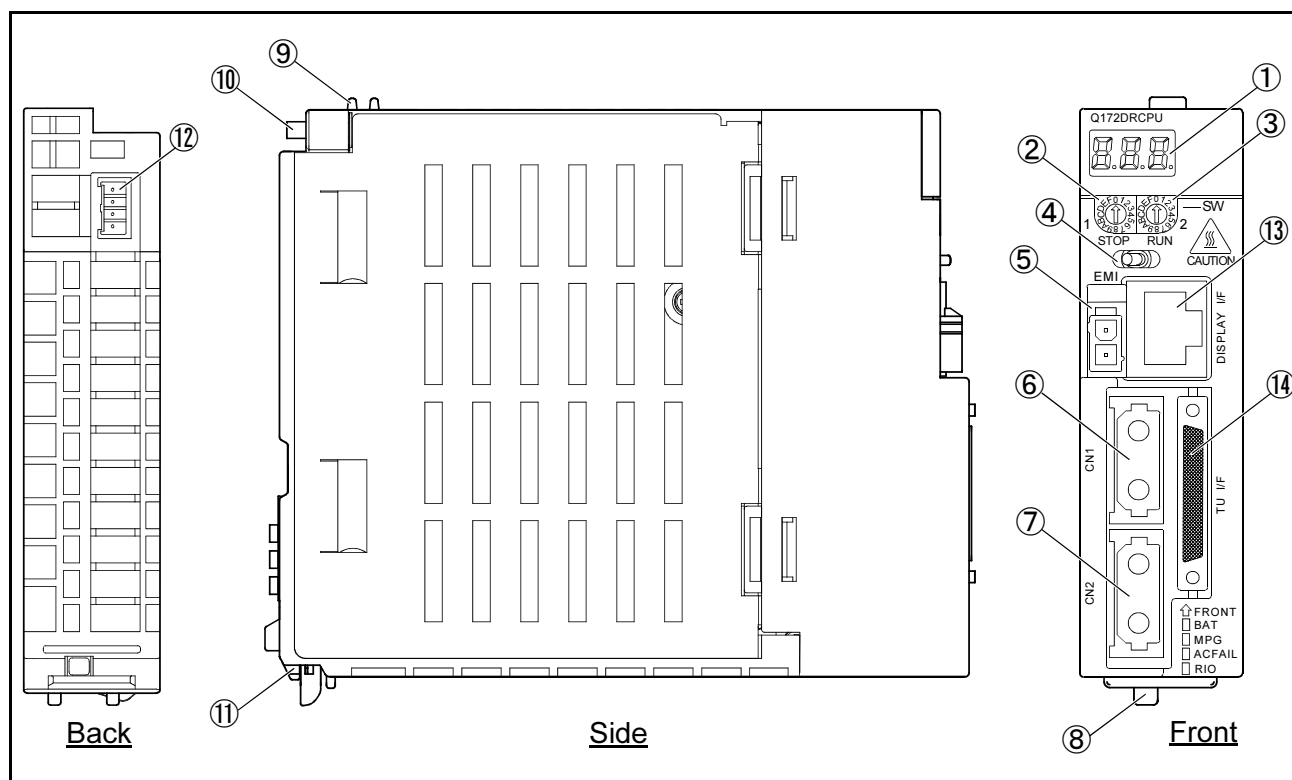

Fig.3-7 : Names of each part of the robot CPU

- ① Seven segments LED.....Indicates operational status and error information
- ② Rotary switch(SW1).....Set up operation mode. Always set it as "0."
- ③ Rotary switch(SW2).....Set up operation mode. Always set it as "0."
- ④ RUN/STOPswitch.....Unused
- ⑤ Emergency stop input(EMI)*1) The input connector which makes the servo amplifier of all the axes the emergency stop at once.
EMI ON (open) : Emergency stop
EMI OFF (Supply DC24V.) : Emergency stop release
- ⑥ CN1 connector*2)Connect to the drive unit
- ⑦ CN2 connector*2)Connect to the servo amplifier of the addition axis(Eight axes)
- ⑧ Lever for unit installation.....Use this lever, when installing the unit in the base unit.
- ⑨ Hook for unit fixing*3) The hook which fixes the unit to the base unit (For the support at installation)
- ⑩ Unit fixing screw..... The screw for fixing to the base unit (M3×13)
- ⑪ The projection for unit fixing The projection for fixing to the base unit
- ⑫ Battery connector(BAT)*4) The connector for connection with battery holder unit Q170DBATC
- ⑬ The connector for the networks (DISPLAY I/F)
The connector of the LAN access for T/B (For R56TB).
- ⑭ RS-422 connector(TU I/F)..... The connector for RS-422 connection with the drive unit

*1) Please be sure to use the emergency stop input cable. The emergency stop cannot be canceled if it does not use. If it manufactures the emergency stop input cable in the customer, cable length should use 30m or less.

*2) Please store in the duct or fix the cable section near robot CPU with the bunch wire rod so that prudence of the cable is not applied to CN1 and CN2 connector section.

*3) It is equipment for the support when installing the unit in the basic base unit. Please be sure to fix the unit to the basic base unit with the attached fixing screw.

*4) Please be sure to use the external battery. Unless the battery cable is connected surely, the program in SRAM with a built-in robot CPU, the parameter, origin position data, etc. are not held.

3.3 Outside dimensions/Installation dimensions

3.3.1 Outside dimensions

(1) Drive unit outside dimension

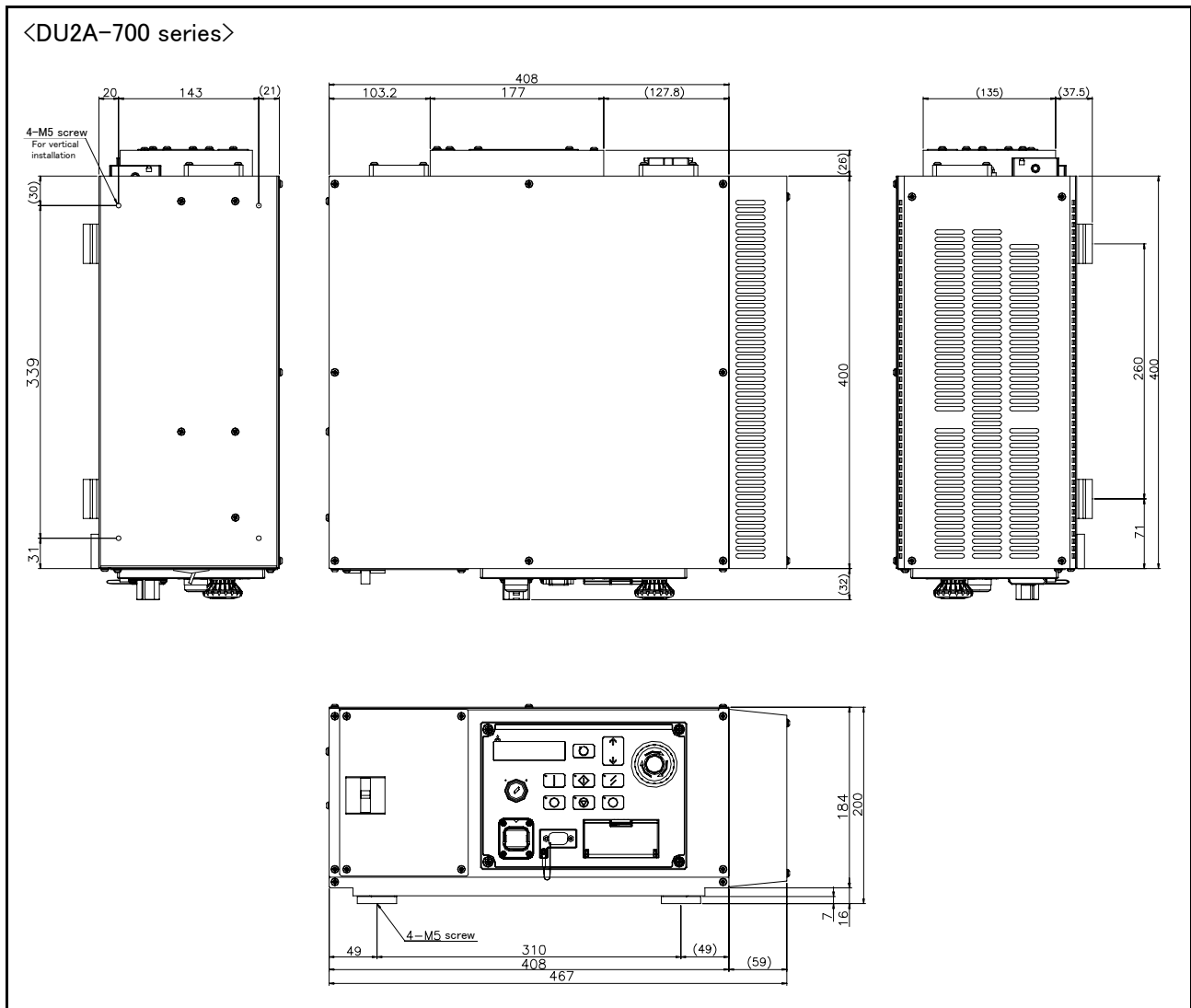

Fig.3-8 : Outside dimensions(DU2A-700 series)

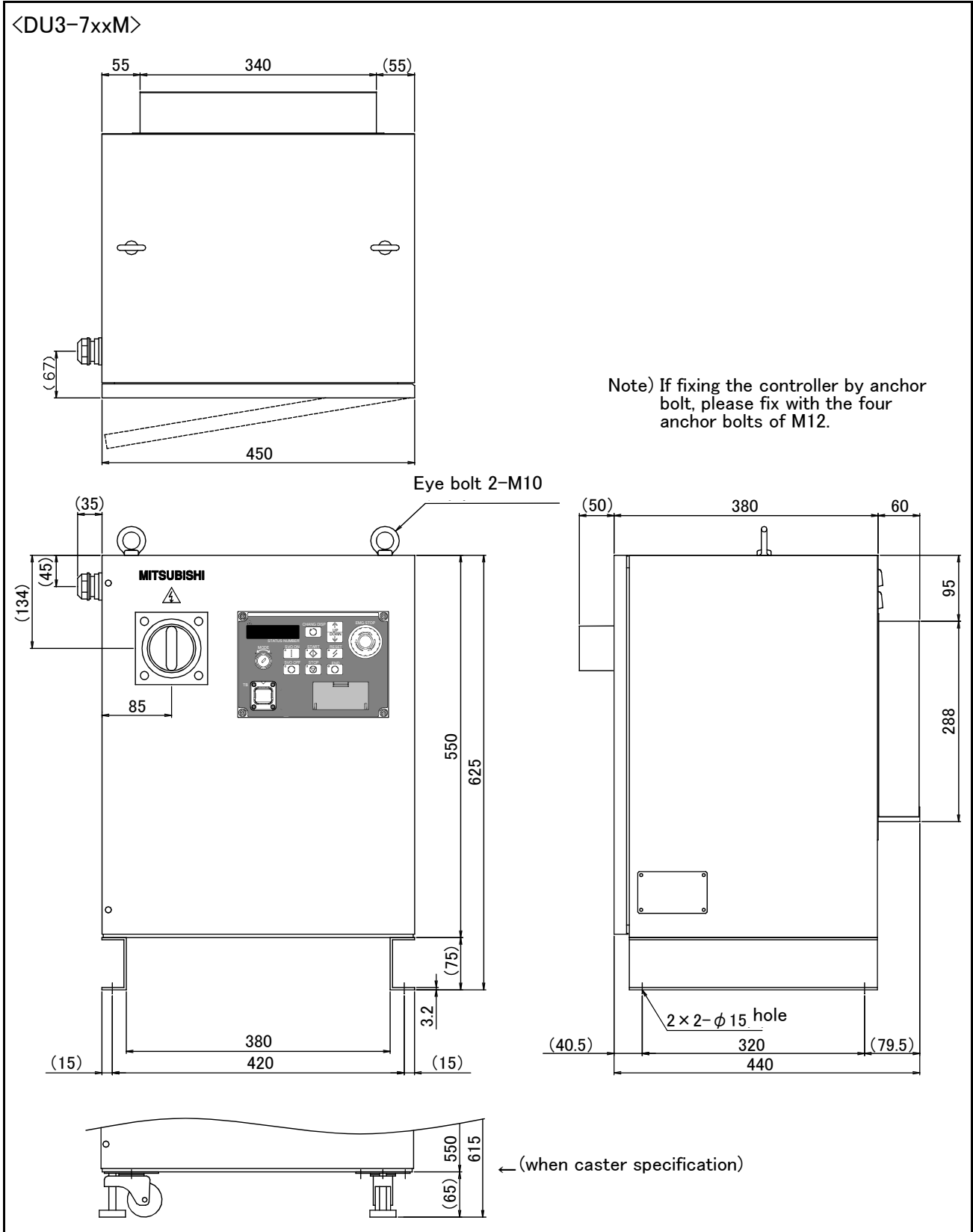

Fig.3-9 : Outside dimensions(DU3-7xxM)

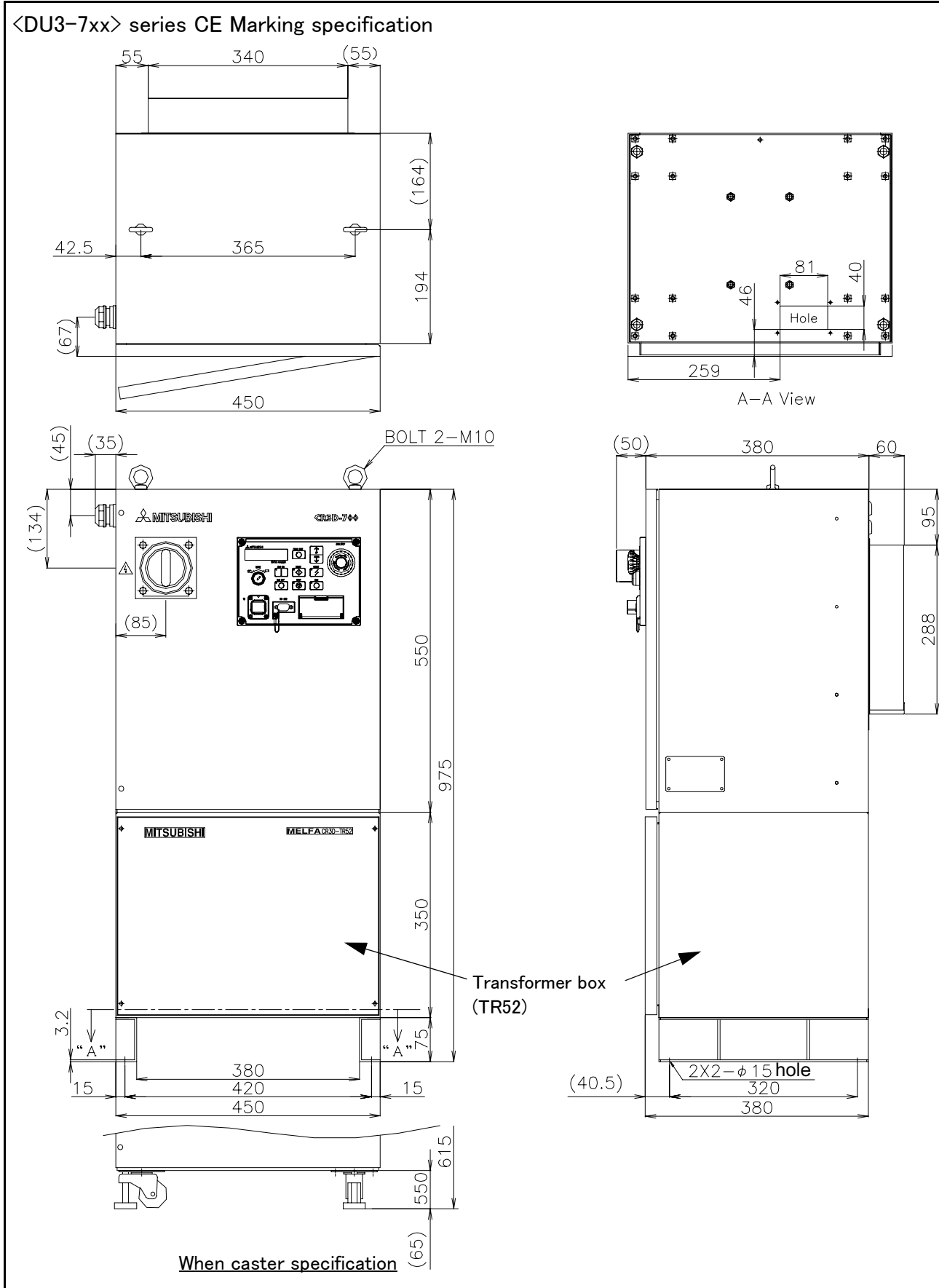

Fig.3-10 : Outside dimensions of controller(DU3-7xx CE Marking)

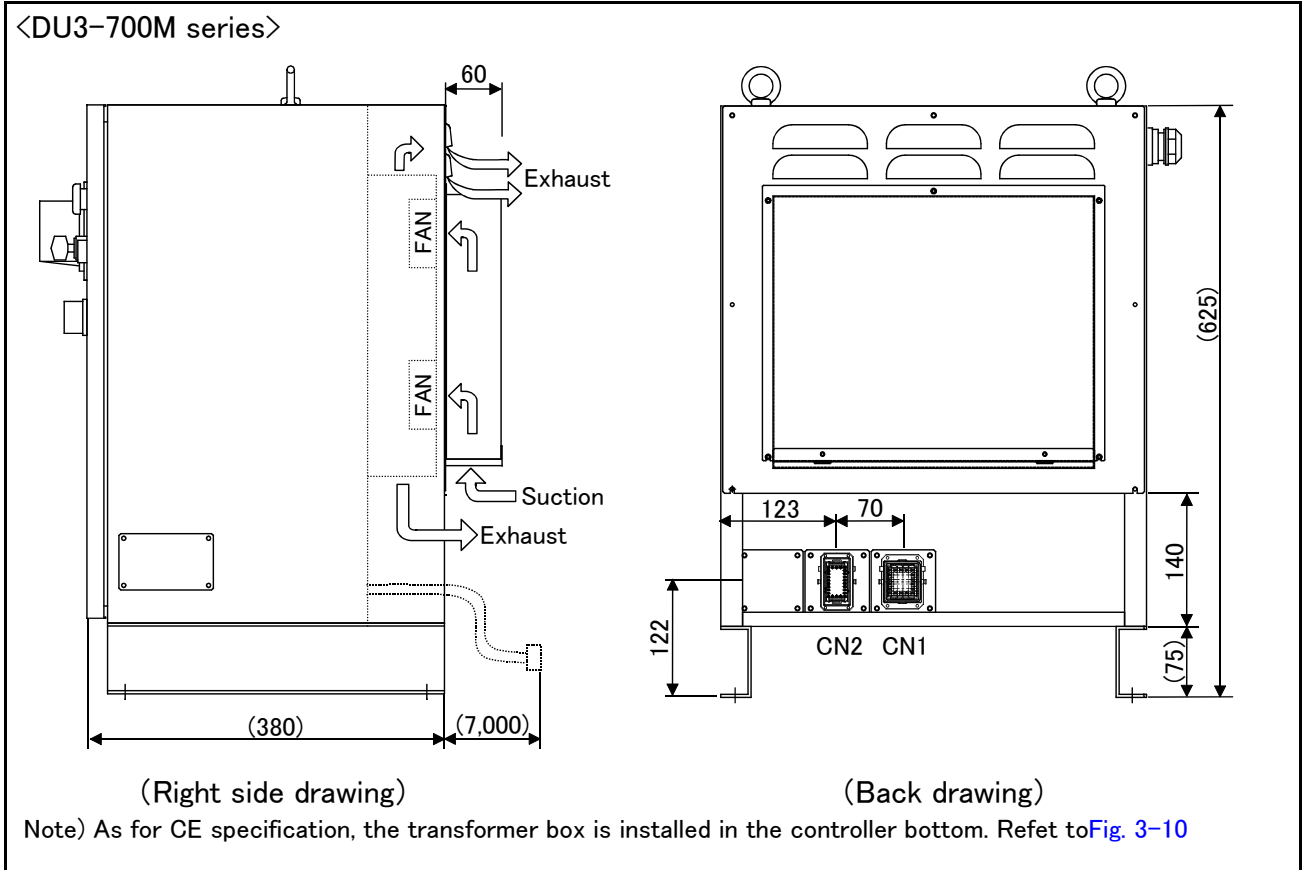

Fig.3-11 : Outside dimensions of controller (DU3-700M Supplement)

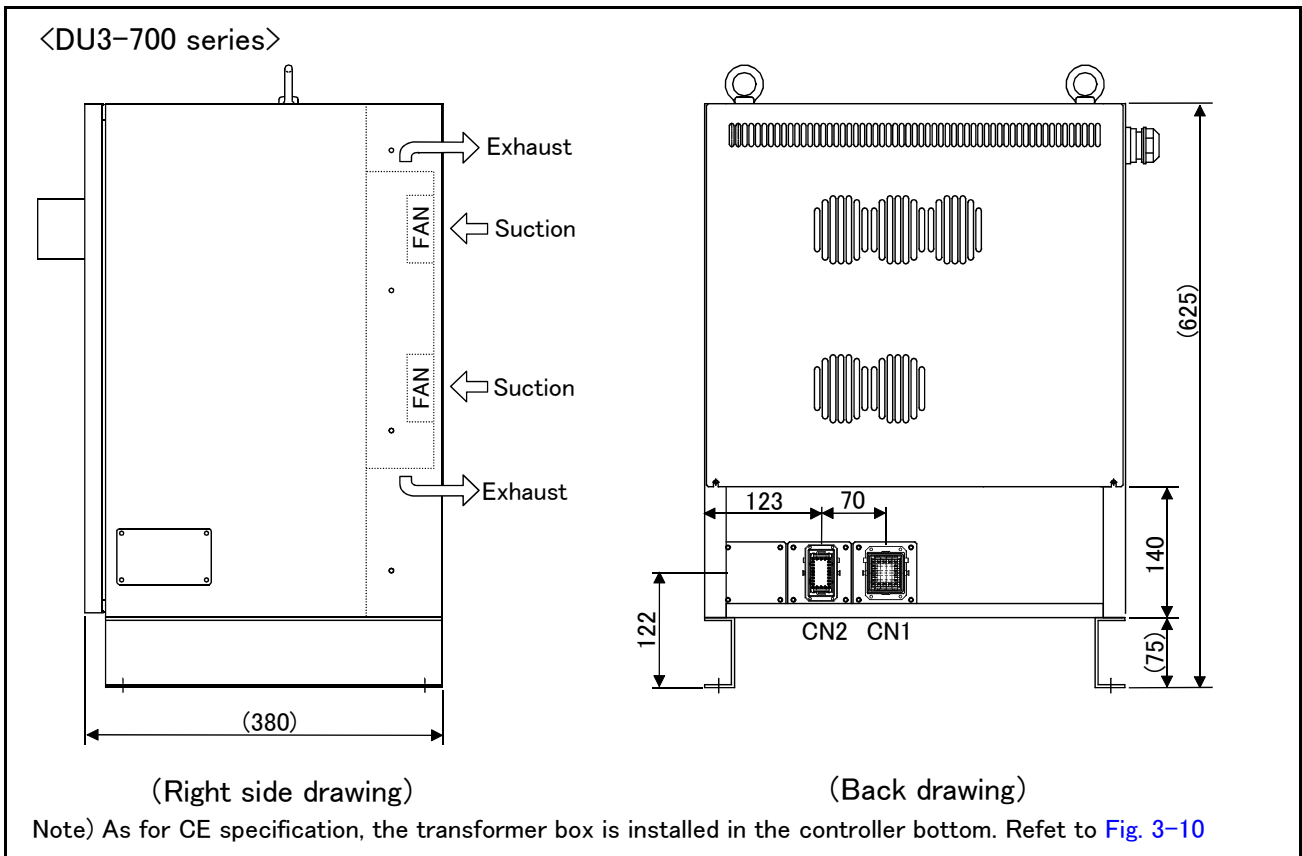

Fig.3-12 : Outside dimensions of controller (DU3-700 Supplement)

(2) Outside dimensions of robot CPU unit

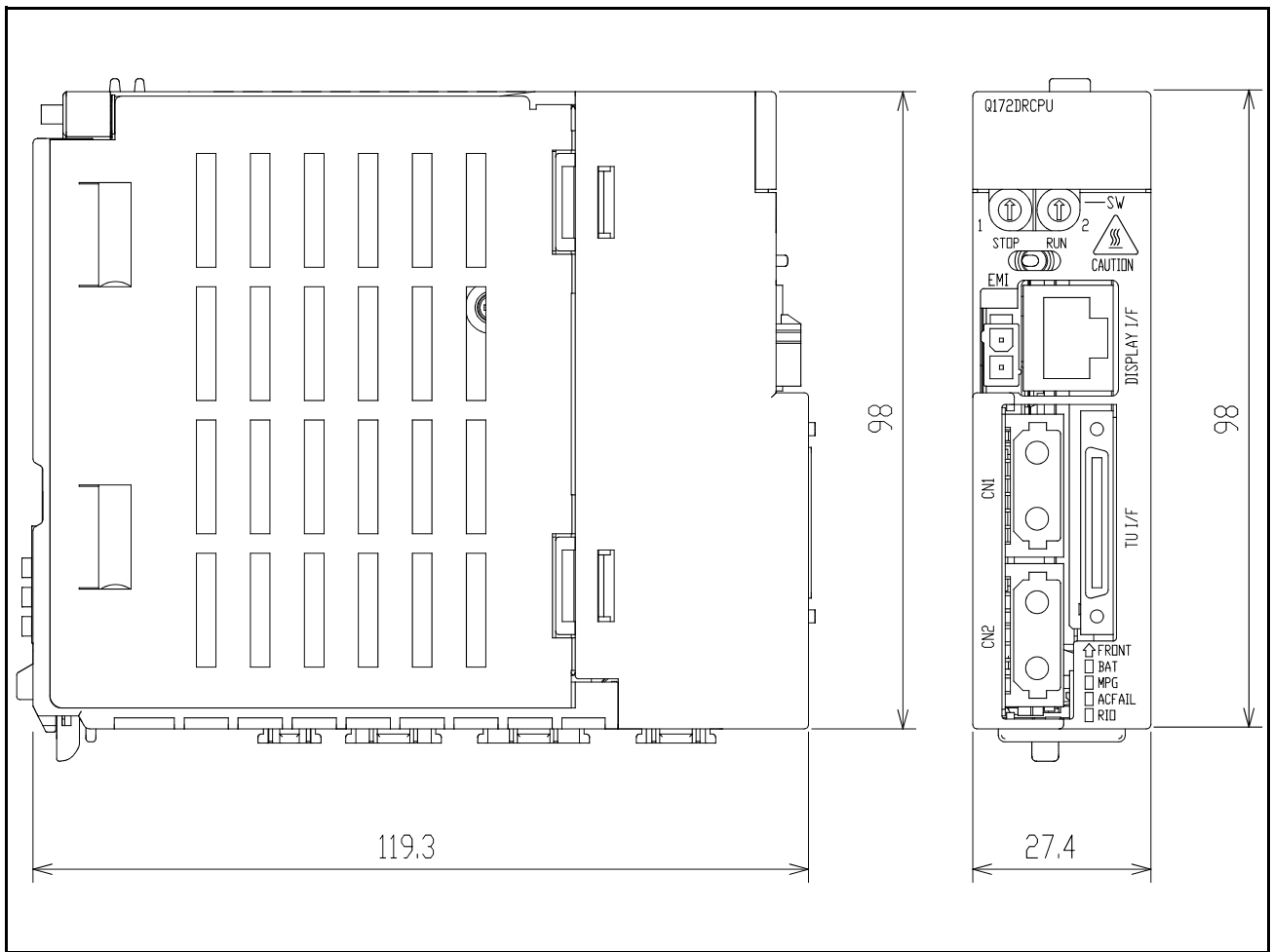

Fig.3-13 : Outside dimensions of robot CPU

(3) Battery unit outside dimension

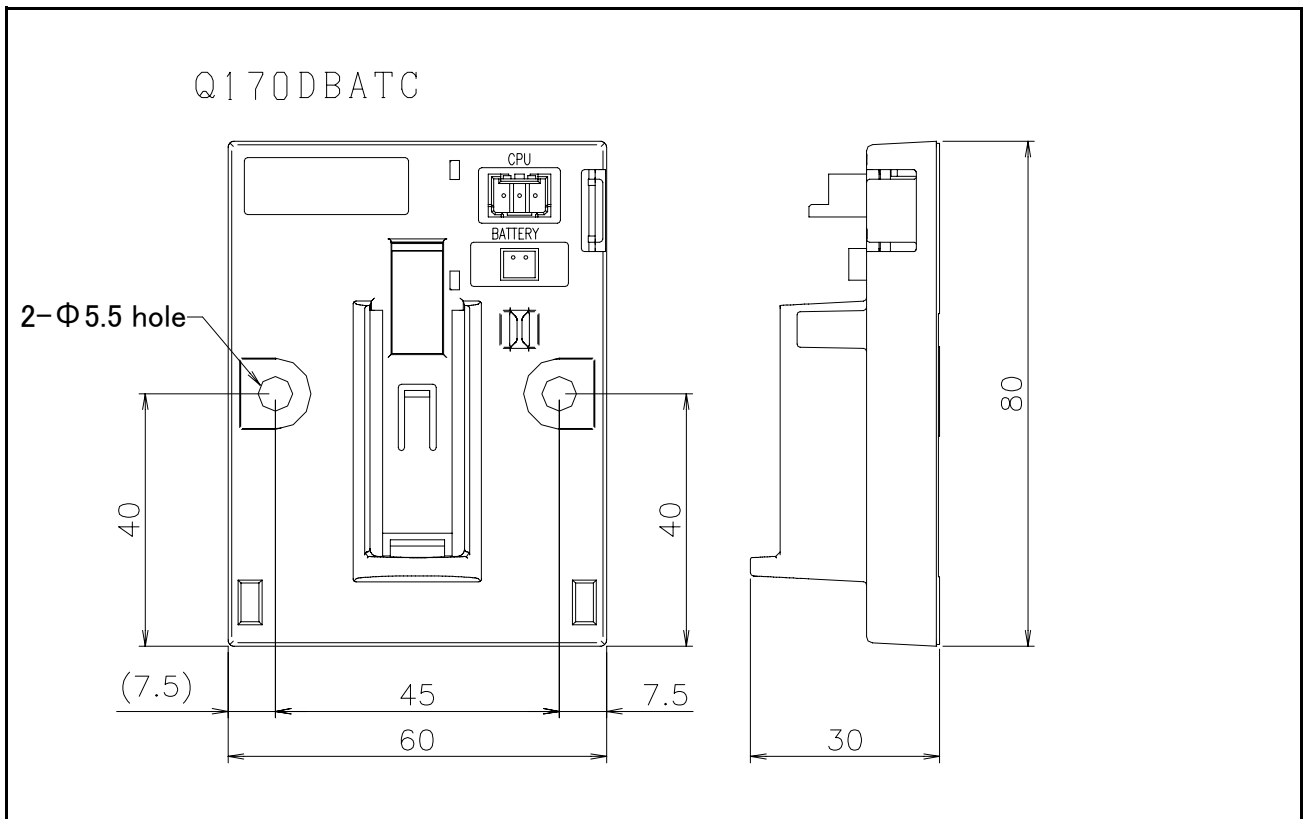
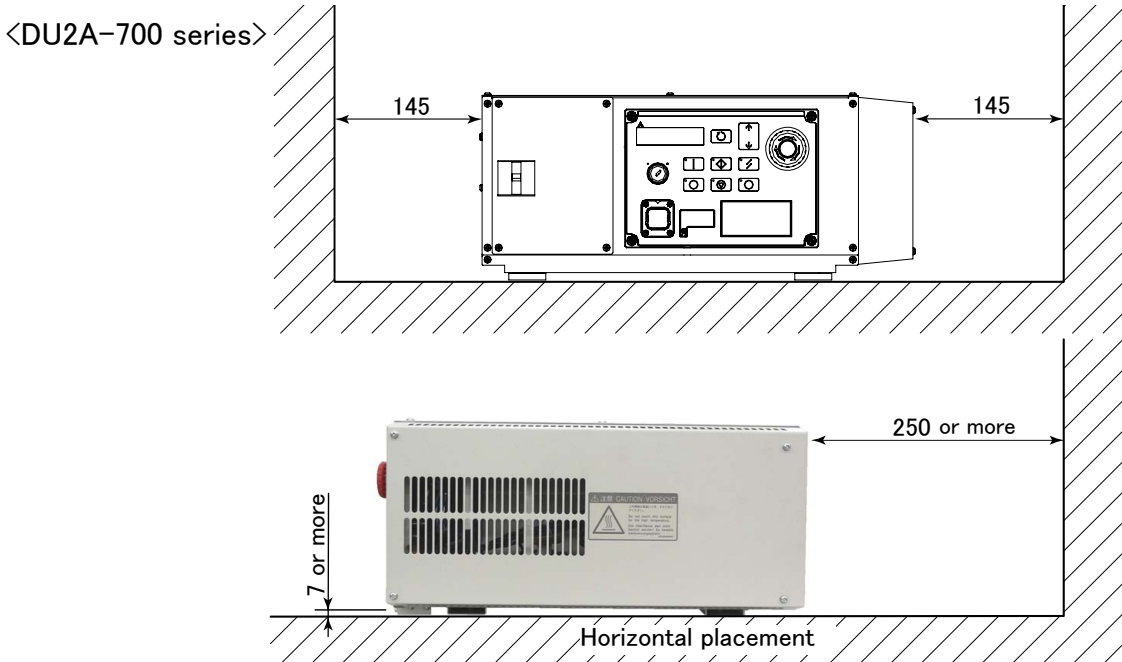

Fig.3-14 : Outside dimensions of battery unit

3.3.2 Installation dimensions

(1) Installation dimensions of drive unit



CAUTION

Use the rubber foot (4 positions) at the bottom of the drive unit as it is, or put the spacer, and leave the space between the installation side and the drive unit installation side more than 7mm when you fix the drive unit with the installation screw. In smaller than 7mm case, the air intake hole at the bottom of the drive unit is occupied, and temperature rises in the board, and causes the trouble.

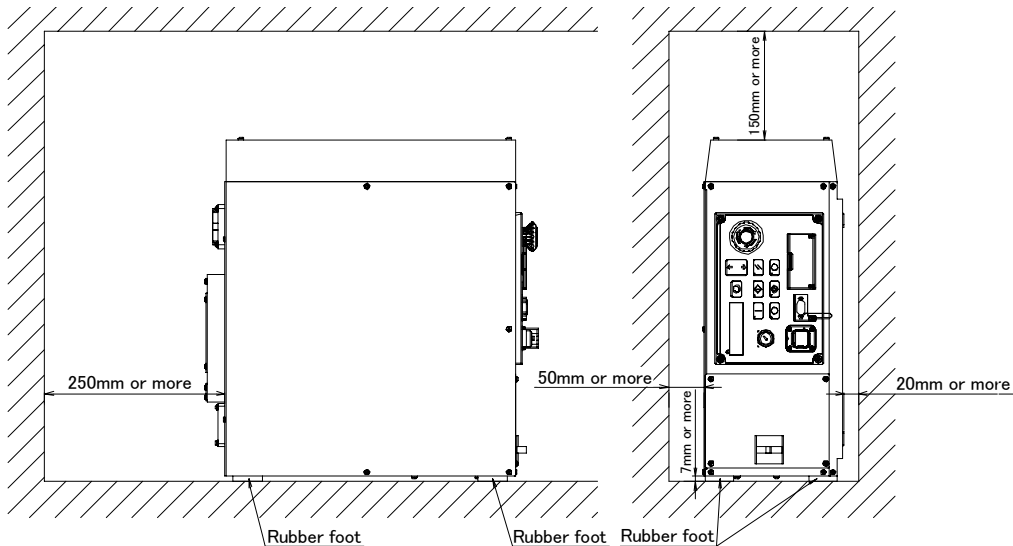

CAUTION

The installation section needs to be fixed so that the drive unit may not fall. When fixing the drive unit with the bolt, please use the bolt of the length which does not protrude 5mm or more into the drive unit case.

- (1) Remove the rubber foot at the bottom of the drive unit (four places, M5 x 10 screws).
- (2) Remove the drive unit side white round seal (four places).
- (3) Use the rubber foot and the 5xM10 screw which were removed by above-mentioned (1), and fix the rubber foot to the screw hole of the seal pasting place of (2).

Fig.3-15 : Installation of drive unit(DU2A-700 series)

CAUTION

When storing the drive unit in a cabinet, etc., take special care to the heat radiating properties and ventilation properties so that the ambient temperature remains within the specification values.

<DU3-700M series>

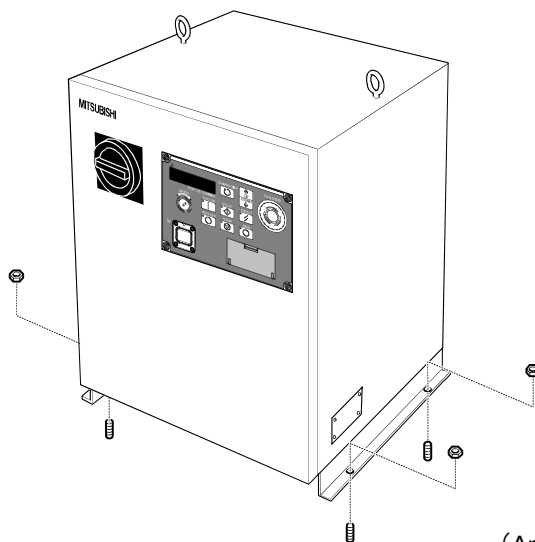

(Anchor bolt installation: 4 places)

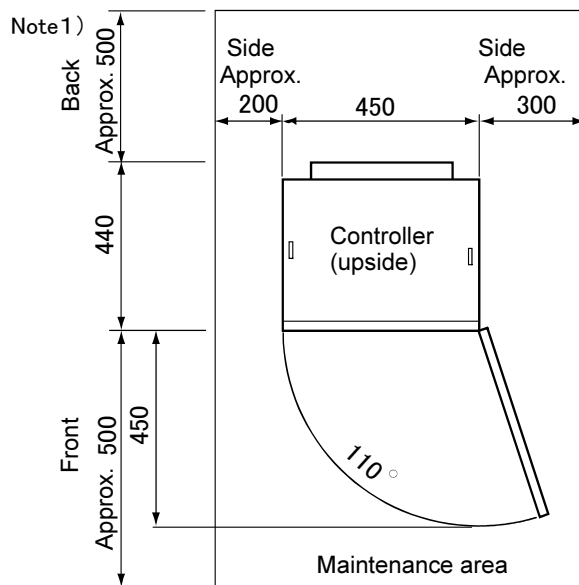

(View from upside)

Note1) The controller sucks in the outside air and discharges the inside air after cooling (Fig. 3-11). The space required for cooling is 100 mm minimum. Reserve approximately 500 mm of space behind the unit as the maintenance work area.

Fig.3-16 : Installation of controller (DU3-700M series)

(2) Robot CPU Unit installation dimensions

Because to improve ventilation and to make unit replacement easy, please secure the following distance between the upper and lower sides of the unit and the structure, etc.

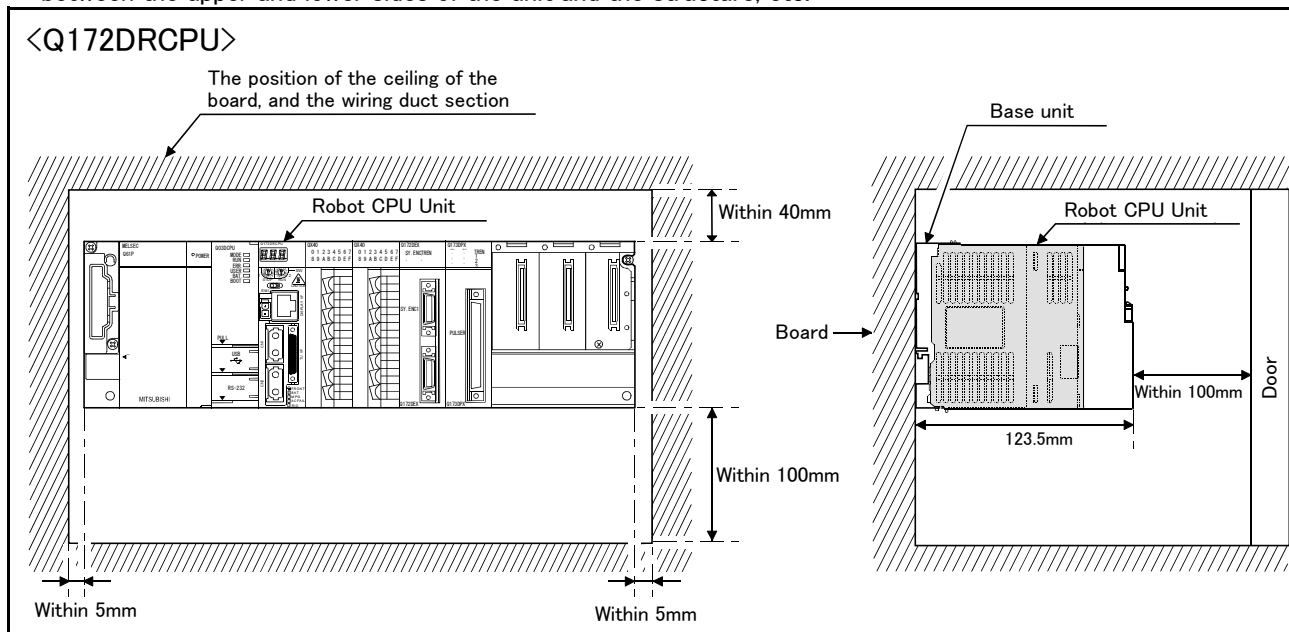

Fig.3-17 : Installation of robot CPU Unit

3.3.3 Cable lead-in and dimension

The controller has the openings parts for pulling out the cable as shown in Fig. 3-18 and Fig. 3-19.

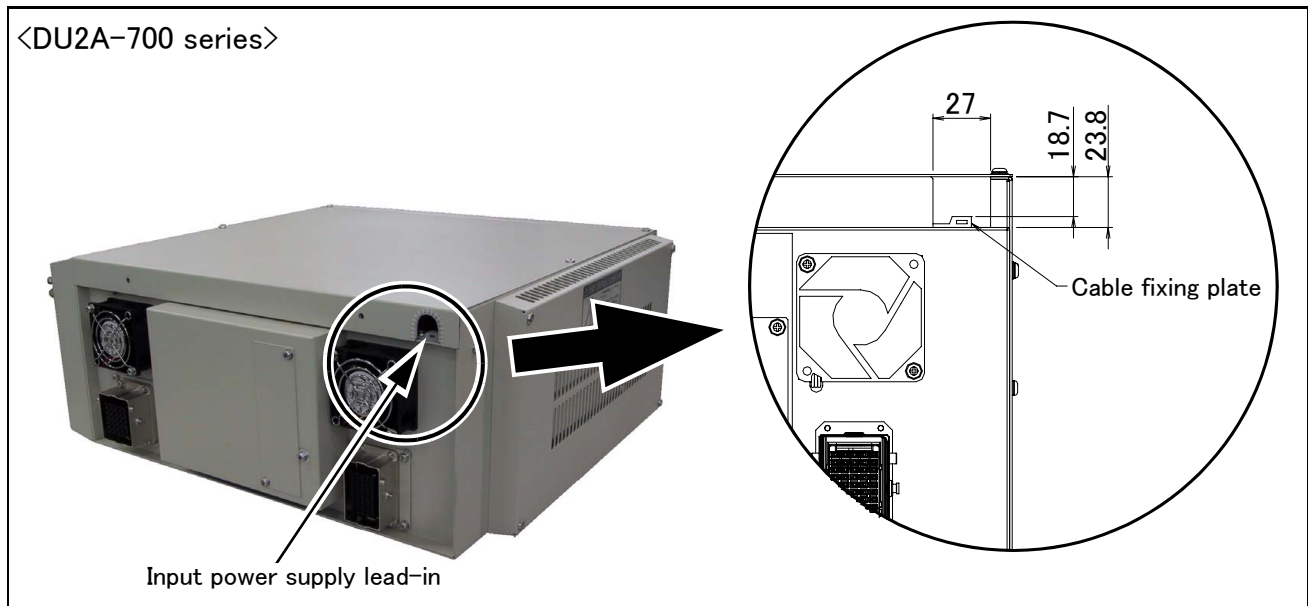

Fig.3-18 : Cable lead-in and dimension of the controller (DU2A-700 series)

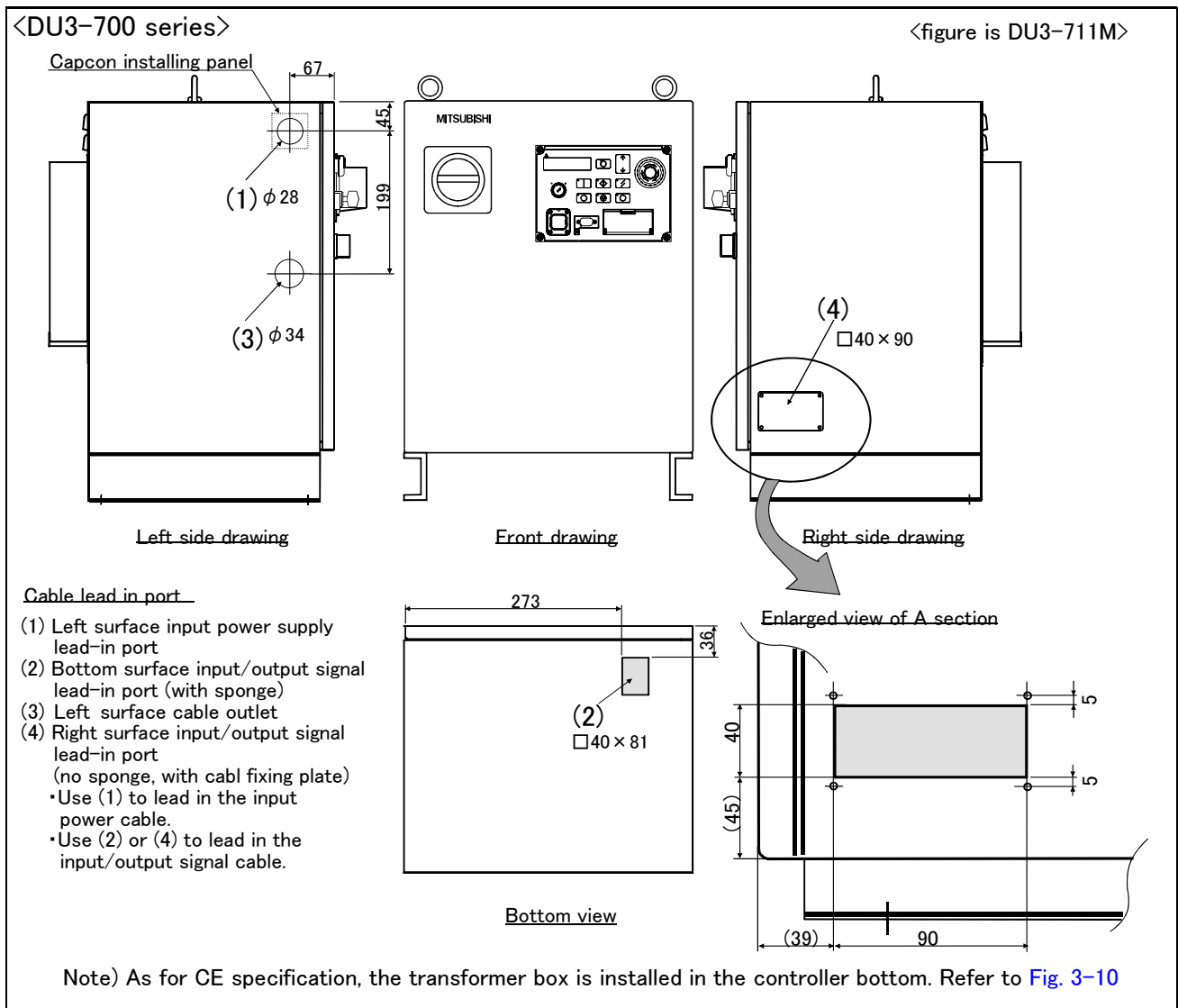

Fig.3-19 : Cable lead-in and dimension of the controller (DU3-700 Series)

3.4 External input/output

3.4.1 Types

- (1) Dedicated input/output.....These inputs and outputs carry out the robot remote operation and status display.
- (2) General-purpose input/output.....These are inputs and outputs that the customer can program for peripheral device control.
- (3) Hand input/output.....These are inputs and outputs related to the hand that the customer can program. (The hand output is an option. The [Page 83, "\(2\) Pneumatic hand interface"](#) is required.)
- (4)Emergency stop/Door switch input.....The wiring for the safe security of the emergency stop etc. is shown in on [Page 63, "3.6 Emergency stop input and output etc."](#) and on [Page 100, "6.1.7 Examples of safety measures"](#).

<For Reference>

Linking our GOT1000 Series (GT15) display equipment to the robot controller over the Ethernet permits you to control robot controller's input/output from a GOT (graphic operation terminal). Refer to the examples of the use of GOT1000 Series display equipment given in a separate document titled "Detail Description of Functions and Operation."

3.5 Dedicated input/output

Show the main function of dedicated input/output in the [Table 3-4](#). Refer to attached instruction manual "Detailed explanations of functions and operations" in the product for the other functions. Each parameter indicated with the parameter name is used by designated the signal No., assigned in the order of input signal No. and output signal No.

Table 3-4 : Dedicated input/output list

Parameter name	Input <small>Note1)</small>			Output	
	Name	Function	Level	Name	Function
TEACHMD	None			Teaching mode output signal	Outputs that the teaching mode is entered.
ATTOPMD	None			Automatic mode output signal	Outputs that the automatic mode is entered.
ATEXTMD	None			Remote mode output signal	Outputs that the remote mode is entered.
RCREADY	None			Controller power ON complete signal	Outputs that external input signals can be received.
AUTOENA	Automatic operation enabled input signal	Allows automatic operation.	L	Automatic operation enabled output signal	Outputs the automatic operation enabled state.
START	Start input signal	Starts all slots.	E	Operating output signal	Outputs that the slot is operating.
STOP	Stop input signal	Stops all slots. The input signal No. is fixed to 0. Note) Use the emergency stop input for stop inputs related to safety.	L	Wait output signal	Outputs that the slot is temporarily stopped.
STOP2	Stop input signal	The program during operation is stopped. Unlike the STOP parameter, change of the signal number is possible. Notes) specification is the same as the STOP parameter.	L	Wait output signal	Outputs that the slot is temporarily stopped.
SLOTINIT	Program reset input signal	Resets the wait state.	E	Program selection enabled output signal	Outputs that the slot is in the program selection enabled state.
ERRRESET	Error reset input signal	Resets the error state.	E	Error occurring output signal	Outputs that an error has occurred.
CYCLE	Cycle stop input signal	Carries out cycle stop.	E	In cycle stop operation output signal	Outputs that the cycle stop is operating.
SRVOFF	Servo ON enabled input signal	Turns the servo OFF for all mechanisms.	L	Servo ON enabled output signal	Outputs servo-on disable status. (Echo back)
SRVON	Servo ON input signal	Turns the servo ON for all mechanisms.	E	In servo ON output signal	Outputs the servo ON state.
IOENA	Operation rights input signal	Requests the operation rights for the external signal control.	L	Operation rights output signal	Outputs the operation rights valid state for the external signal control.
MELOCK	Machine lock input signal	Sets/resets the machine lock state for all mechanisms.	E	In machine lock output signal	Outputs the machine lock state.
SAFEPOS	Evasion point return input signal	Requests the evasion point return operation.	E	In evasion point return output signal	Outputs that the evasion point return is taking place.
OUTRESET	General-purpose output signal reset	Resets the general-purpose output signal.	E	None	
EMGERR	None			Emergency stop output signal	Outputs that an emergency stop has occurred.
S1START : S32START	Start input	Starts each slot.	E	In operation output	Outputs the operating state for each slot.
S1STOP : S32STOP	Stop input	Stops each slot.	L	In wait output	Outputs that each slot is temporarily stopped.

Parameter name	Input Note 1)			Output	
	Name	Function	Level	Name	Function
PRGSEL	Program selection input signal	Designates the setting value for the program No. with numeric value input signals.	E	None	
OVRDSEL	Override selection input signal	Designates the setting value for the override with the numeric value input signals.	E	None	
IODATA Note2)	Numeric value input (start No., end No.)	Used to designate the program name, override value., mechanism value.	L	Numeric value output (start No., end No.)	Used to output the program name, override value., mechanism No.
PRGOUT	Program No. output request	Requests output of the program name.	E	Program No. output signal	Outputs that the program name is being output to the numeric value output signal.
LINEOUT	Line No. output request	Requests output of the line No.	E	Line No. output signal	Outputs that the line No. is being output to the numeric value output signal.
OVRDOUT	Override value output request	Requests the override output.	E	Override value output signal	Outputs that the override value is being output to the numeric value output signal.
ERROUT	Error No. output request	Requests the error No. output.	E	Error No. output signal	Outputs that the error No. is being output to the numeric value output signal.
JOGENA	Jog valid input signal	Validates jog operation with the external signals	E	Jog valid output signal	Outputs that the jog operation with external signals is valid.
JOGM	Jog mode input 2-bit	Designates the jog mode.	L	Jog mode output 2-bit	Outputs the current jog mode.
JOG+	Jog feed + side for 8-axes	Requests the + side jog operation.	L	None	
JOG-	Jog feed - side for 8-axes	Requests the - side jog operation.	L	None	
HNDCTRL1 : HNDCTRL3	None			Mechanism 1 hand output signal status : Mechanism 3 hand output signal status	Mechanism 1: Outputs the status of general-purpose outputs 900 to 907. Mechanism 2: Outputs the status of general-purpose outputs 910 to 917. Mechanism 3: Outputs the status of general-purpose outputs 920 to 927.
HNDSTS1 : HNDSTS3	None			Mechanism 1 hand input signal status : Mechanism 3 hand input signal status	Mechanism 1: Outputs the status of hand inputs 900 to 907. Mechanism 2: Outputs the status of hand inputs 910 to 917. Mechanism 3: Outputs the status of hand inputs 920 to 927.
HNDERR1 : HNDERR3	Mechanism 1 hand error input signal : Mechanism 3 hand error input signal	Requests the hand error occurrence.	L	Mechanism 1 hand error output signal : Mechanism 3 hand error output signal	Outputs that a hand error is occurring.
AIRERR1 : AIRERR3	Pneumatic pressure error 1 input signal : Pneumatic pressure error 3 input signal	Request the pneumatic pressure error occurrence.	L	Pneumatic pressure error 1 output signal. : Pneumatic pressure error 3 output signal.	Outputs that a pneumatic pressure error is occurring.
M1PTEXC : M3PTEXC	None		L	Maintenance parts replacement time warning signal	Outputs that the maintenance parts have reached the replacement time.
USERAREA Note3)	None			User-designated area 8-points	Outputs that the robot is in the user-designated area.

Note1) The level indicates the signal level.

L: Level signal → The designated function is validated when the signal is ON, and is invalidated when the signal is OFF.

E: Edge signal → The designated function is validated when the signal changes from the OFF to ON state, and the function maintains the original state even when the signal then turns OFF.

Note2) Four elements are set in the order of input signal start No., end No., output signal start No. and end No.

Note3) Up to eight points can be set successively in order of start output signal No. and end output signal No.

3.6 Emergency stop input and output etc.

Do wiring of the external emergency stop, the special stop input, the door switch, and the enabling device from the "special input/output" terminal connector.

Table 3-5 : Special input/output terminal

Item	Name	Function
Input	Emergency stop	Applies the emergency stop. Dual emergency line
Input	Special stop input	Applies the stop. (Refer to Page 67, "3.6.2 Special stop input(SKIP)")
Input	Door switch	Servo-off. Dual line, normal close (Page 69, "3.6.3 Door switch function")
Input	Enabling device	Servo-off. Dual line, normal close (Page 69, "3.6.4 Enabling device function")
Output	Robot error output	Contact is opening during error occurrence
Output	Mode output	MANUAL mode: contactor is opening, AUTO mode: contactor is closing.
Output	Magnet contactor control connector output for addition axes	When an additional axis is used, the servo ON/OFF status of the additional axis can be synchronized with the robot arm. (Page 76, "3.8 Magnet contactor control connector output (AXMC) for addition axes")

*At the time of the power supply OFF, the output point of contact is always open.

[Note] The contact capacity of each input/output terminal is DC24V/10mA – 500mA. Don't connect the equipment except for this range. The use exceeding contact capacity causes failure.

Pin number assignment of each terminal and the circuit diagram are shown in Fig. 3-22.

3.6.1 Connection of the external emergency stop

The external emergency stop input and door switch input and enabling device input are opened at shipment as shown in Fig. 3-22.

Connect the external emergency stop switch and door switch with the following procedure.

[Caution] Since the emergency stop, the enabling device, and the door switch circuits are made dual circuits inside the controller, all the emergency stop switches should use dual contact type. Remove the contact capacity sticker stuck on the connector (EMGIN, EMGOUT, SKIP) and connect the emergency switch.

- 1) Prepare the "emergency stop switch", "enabling device" and "door switch".
- 2) Securely connect the external emergency stop's contacts across 3A-4A, 3B-4B, and the door switch's contacts across 8A-9A, 8B-9B, and the enabling device switch's contacts across 10A-11A, 10B-11B, on the terminal block.

[Caution] When wiring the emergency stop switch (double emergency line type) and SKIP input signal, wire both contacts to the two terminal blocks on the controller. If both contacts are wired to only one of the terminal blocks, errors cannot be cancelled using the door switch. The cable uses the shielded cable and installs the ferrite core. Install the ferrite core in less than 30cm from the contact button.



CAUTION You should always connect doubly connection of the emergency stop, the door switch, and the enabling switch. (Connect with both of side-A and side-B of the controller rear connector) In connection of only one side, if the relay of customer use should break down, it may not function correctly.



CAUTION Please be sure to check that each function operates normally for the prevention of malfunction. Surely check that the operation of the emergency stop of the robot controller, the emergency stop of the teaching pendant, the customer's emergency stop, etc are normally.

⚠ CAUTION Be sufficiently careful and wiring so that two or more emergency stop switches work independently. Don't function only on AND conditions (Two or more emergency stop switch status are all ON).

<DU2A-700>

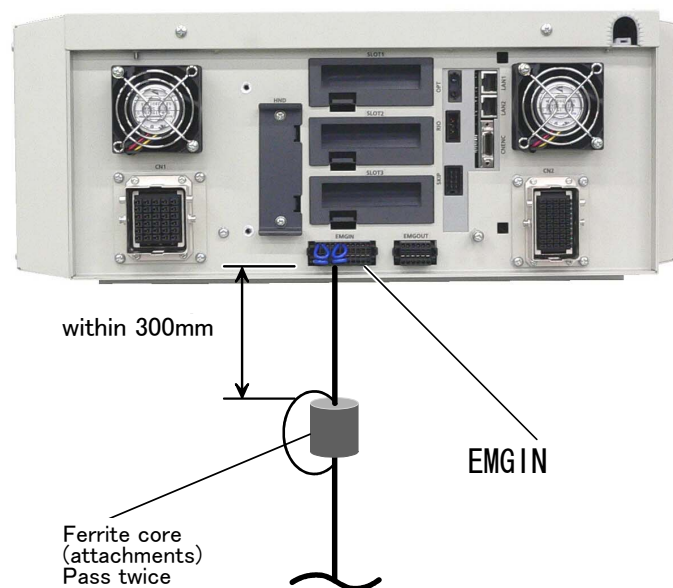

Pin allotment of EMGIN and the EMGOUT connector is shown in [Fig. 3-22](#).

Fig.3-20 : emergency stop cable connection(DU2A-700)

<DU3-700/700M>

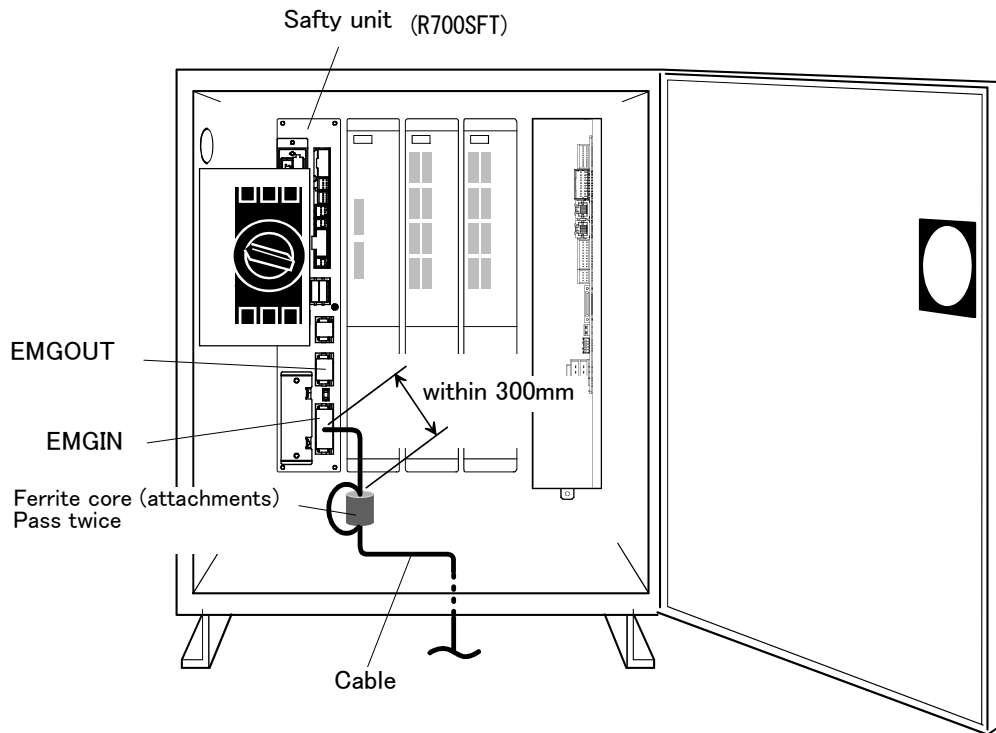

Pin allotment of EMGIN and the EMGOUT connector is shown in [Fig. 3-22](#).

Fig.3-21 : Emergency stop cable connection(DU3-700)

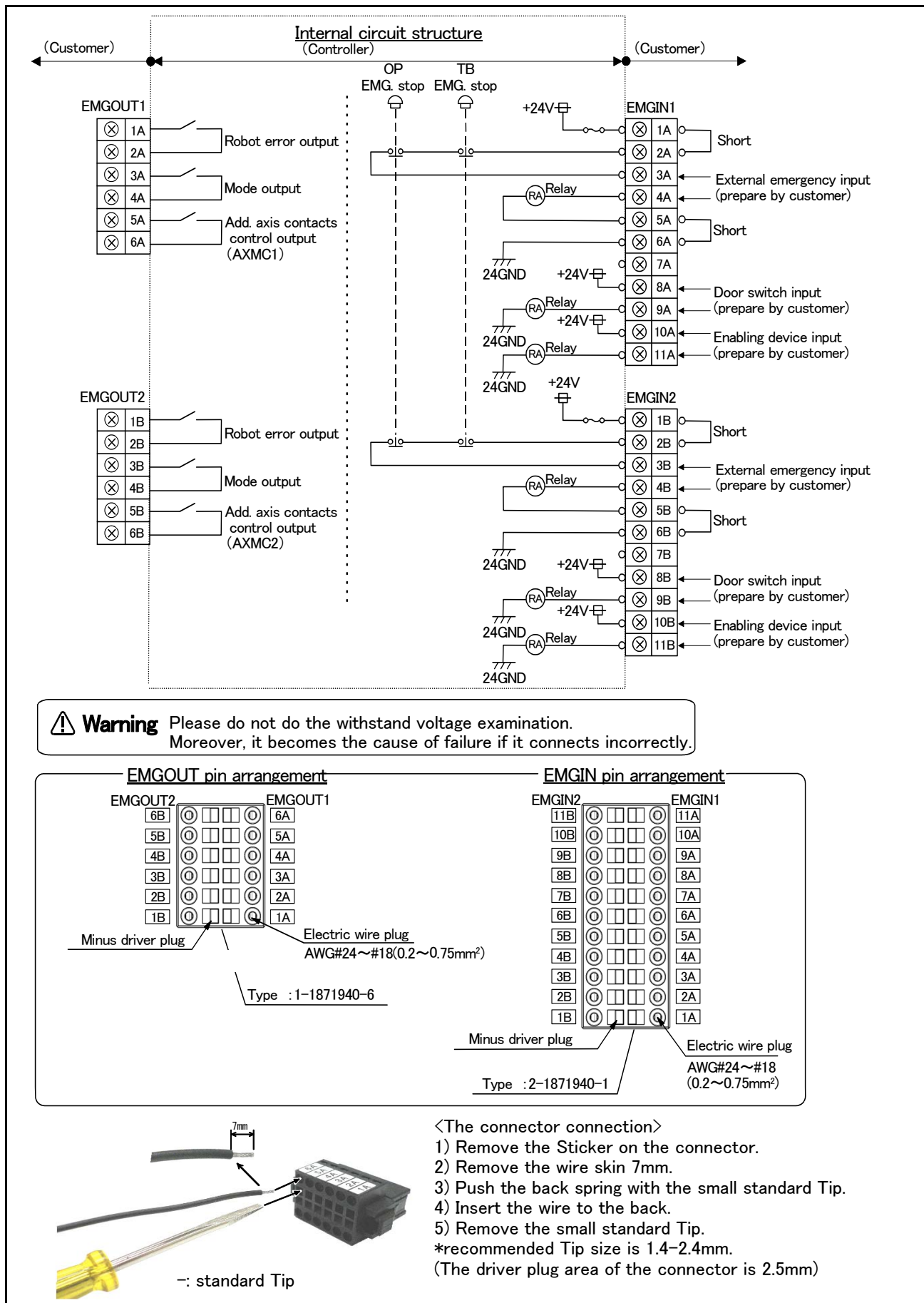

Fig.3-22 : External emergency stop connection

⚠ CAUTION Please be sure to install the emergency stop switch and its connection to the controller, to stop the robot immediately at emergency

⚠ CAUTION Be careful of the short circuit at cable connection. And, don't give plating solder to the electric wire. Loose connection may occur.

3.6.2 Special stop input(SKIP)

The skip is the input signal to stop the robot. Wire 1A-1B of the special stop connector (SKIP) shown in [Page 68, "Fig.3-23 : Connection of the special-stop-input"](#).

Table 3-6 : Special stop input electric specification

Item		Specifications	Internal circuit
Type		DC input	
No. of input point		1	
Insulation method		Photo-coupler insulation	
Rated input voltage		DC24V	
Rated input current		approx. 11mA	
Working voltage range		DC 21.6 ~ 26.4V (Ripple rate within 5%)	
ON voltage/ON current		DC 8V or more / 2mA or more	
OFF voltage/OFF current		DC 4V or less / 1mA or less	
Input resistance		approx. 2.2 k Ω	
Response time	OFF → ON	1ms or less	
	ON → OFF	1ms or less	
Common method		1 point per common	
External wire connection method		Connector	

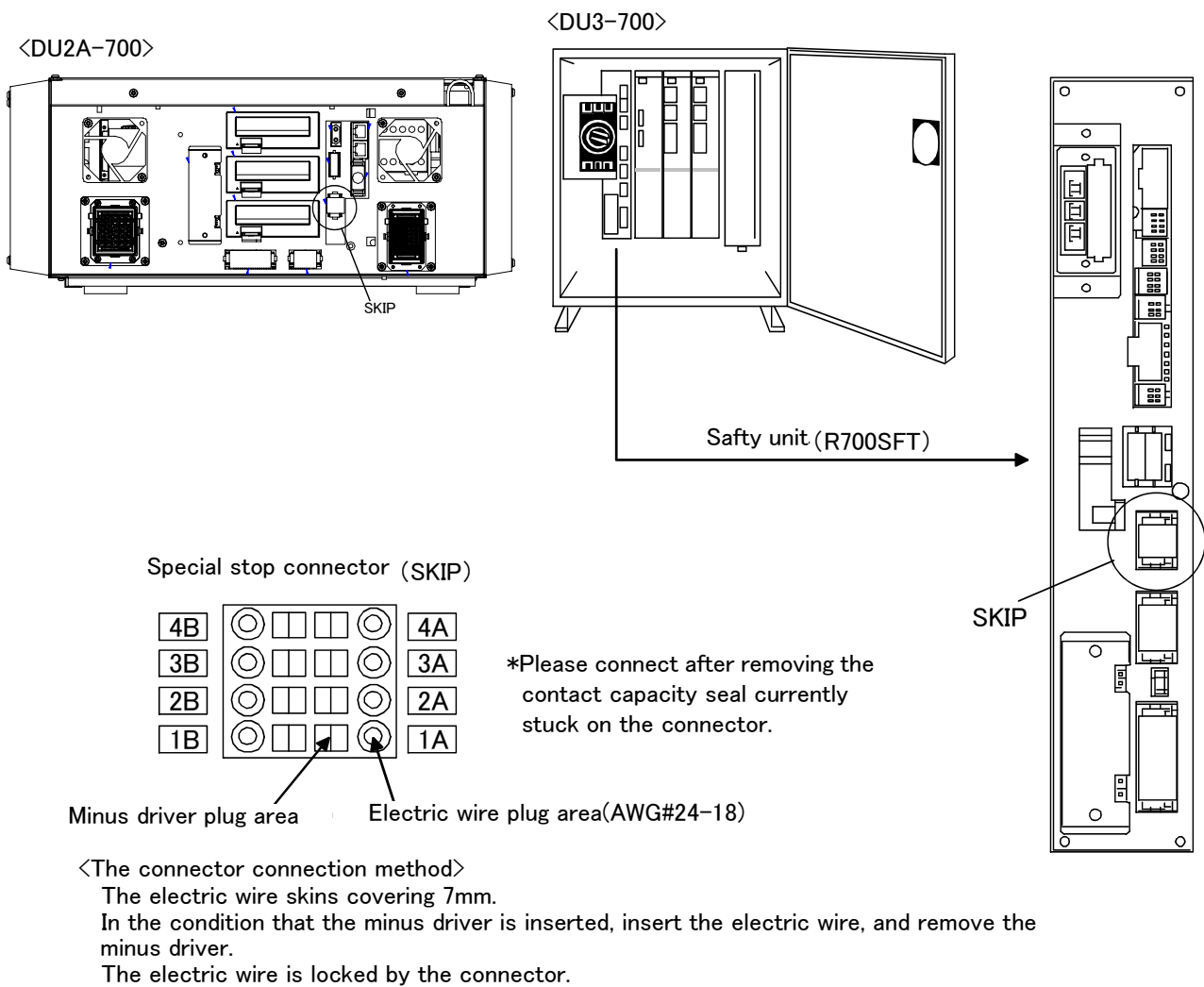

Fig.3-23 : Connection of the special-stop-input

3.6.3 Door switch function

This function retrieves the status of the switch installed on the door of the safety fence, etc., and stops the robot when the door is opened. This differs from an emergency stop in that the servo turns OFF when the door is opened and an error does not occur. Follow the wiring example shown in Fig. 3-22, and wire so that the contact closes when the door is closed. Details of this function according to the robot status are shown below.

*During automatic operationWhen the door is opened, the servo turns OFF and the robot stops. An error occurs.

The process of the restoration : Close the door, reset the alarm, turn on the servo, and restart

*During teaching.....Even when the door is opened, the servo can be turned ON and the robot moved using the teaching pendant.

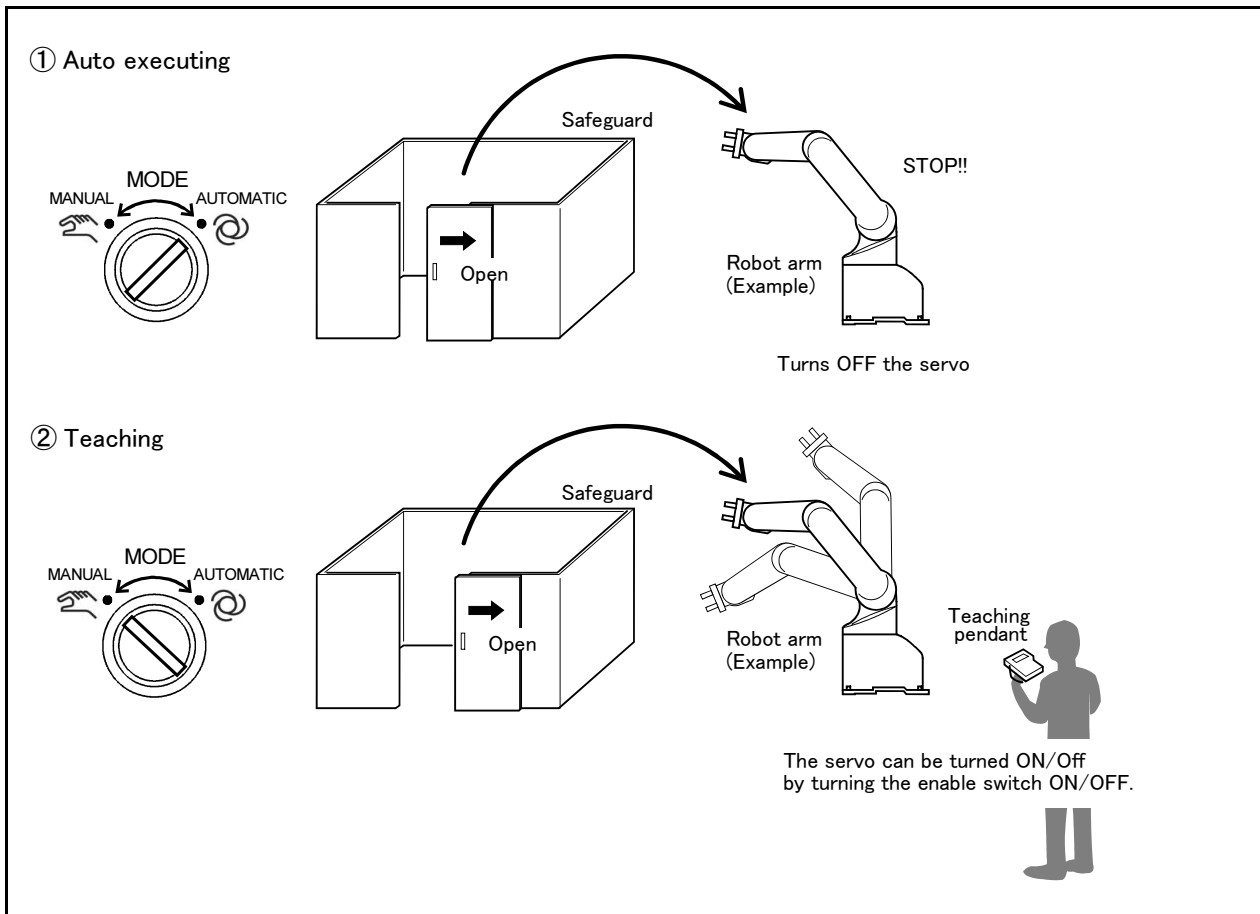

Fig.3-24 : Door switch function

3.6.4 Enabling device function

When the abnormalities occur in teaching operations etc., the robot's servo power can be immediately cut only by switch operation of the enabling device*1) (servo-off), and the safety increases. To use the robot safely, please be sure to connect the enabling device.

(1) When door is opening

Please do teaching by two-person operations. One person has T/B, the other has enabling device. Turn on the servo power, in the condition that both of switches are pushed. (Enable switch of T/B and enabling device) Then the jog operation will be available. You can off the servo power only by releasing the switch of the enabling device. And, care that the servo-on and releasing the brake cannot be done in the condition that the switch of the enabling device is released.

(2) When door is closing

You can turn on the servo power by operation of only T/B. In this case perform jog operation outside the safeguard sure.

*1) Recommendation products: HE1G-L20MB (IDEC)

(3) Automatic Operation/Jog Operation/Brake Release and Necessary Switch Settings

The following is a description of various operations performed on the robot and switch settings that are required.

Table 3-7 : Various operations and necessary switch settings

No	Operation	Related switch settings ^{Note1)}					Description
		Mode of controller	T/B enable/disable	T/B enable switch	Enabling device input terminal	Door switch input terminal	
1	Jog operation	Manual	Enable	ON	Close(ON)	—	If the enabling device input is set to Close (On), the state of door switch input does not matter.
2	Jog operation ^{Note2)}	Manual	Enable	ON	Open(OFF)	Close (Door Close)	If the enabling device input is set to Open (Off), door switch input must be in a state of Close
3	Brake release ^{Note3)}	Manual	Enable	ON	Close(ON)	—	Irrespective of the state of door switch input, enabling device input must be in a state of Close (On).
4	Automatic operation	Automatic	Disable	—	—	Close (Door Close)	Door switch input must always be in a state of Close (Door Close).

Note1) “—” in the table indicates that the state of switch concerned does not matter.

Note2) Jog operation, if door switch input is set for Close (Door Close), must be performed outside the safety barrier.

Note3) It is imperative that brake release operation be carried out by two persons. One person turns on the enabling device (“Close” on the enabling device input terminal) while the other manipulates the T/B. Brake release can be effected only when both of the enabling switch device and the T/B enable switch are placed in intermediate position (lightly gripped position). At this point, the state of door switch input does not matter.

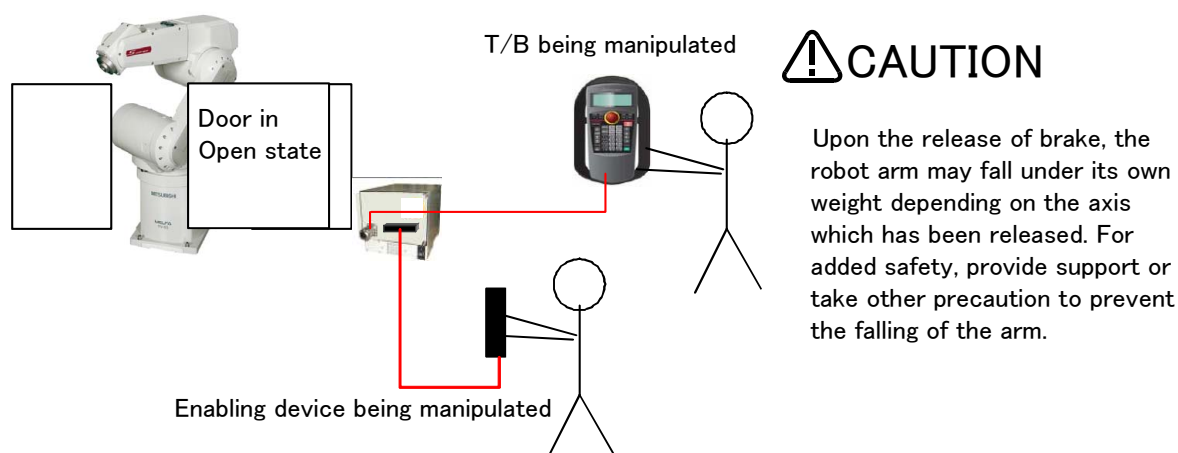

Fig.3-25 : Brake release operation

3.7 Additional Axis Function

This controller is equipped with an additional axis interface for controlling an additional axis when a traveling axis or rotary table is added to the robot. A maximum of eight axes of servo motors can be controlled at the same time by connecting a general-purpose servo amplifier (MR-J3-B series) that supports Mitsubishi's SSC Net III . Refer to the separate "Additional axis interface Instruction Manual" for details on the additional axis function.

3.7.1 Wiring of the Additional Axis Interface

Table 3-8 shows the connectors for additional axes inside the controller and Fig. 3-26, Fig. 3-27, shows a connection example (configuration example). The magnet contactor control connector for additional axes, AXMC1, is designed to accommodate circuit connection with improved safety in Mitsubishi's industrial robot systems connecting additional axes.

Please be sure to install the noise filter in the power supply line of addition axis servo amplifier and to use the robot safely. The example of the installation of the noise filter is shown in Page 74, "(1) Example of the installation of the noise filter". Install by one of the methods.

Please implement the appropriate circuit connection by refer to Page 76, "3.8 Magnet contactor control connector output (AXMC) for addition axes".

Table 3-8 : Dedicated Connectors inside the Controller

Name	Connector name	Details
Connector for additional axes	CN2 ^{Note1)}	The connector for connecting robot CPU with general-purpose servo amplifier.
Magnet contactor control connector for additional axes	EMGOUT	This contact output is used to turn ON/OFF the motor power by connecting to general-purpose servo amplifiers.

Note1) Since the CN1 connector is used for the robot arms, it cannot be used for the addition axis.

<DU2A-700>

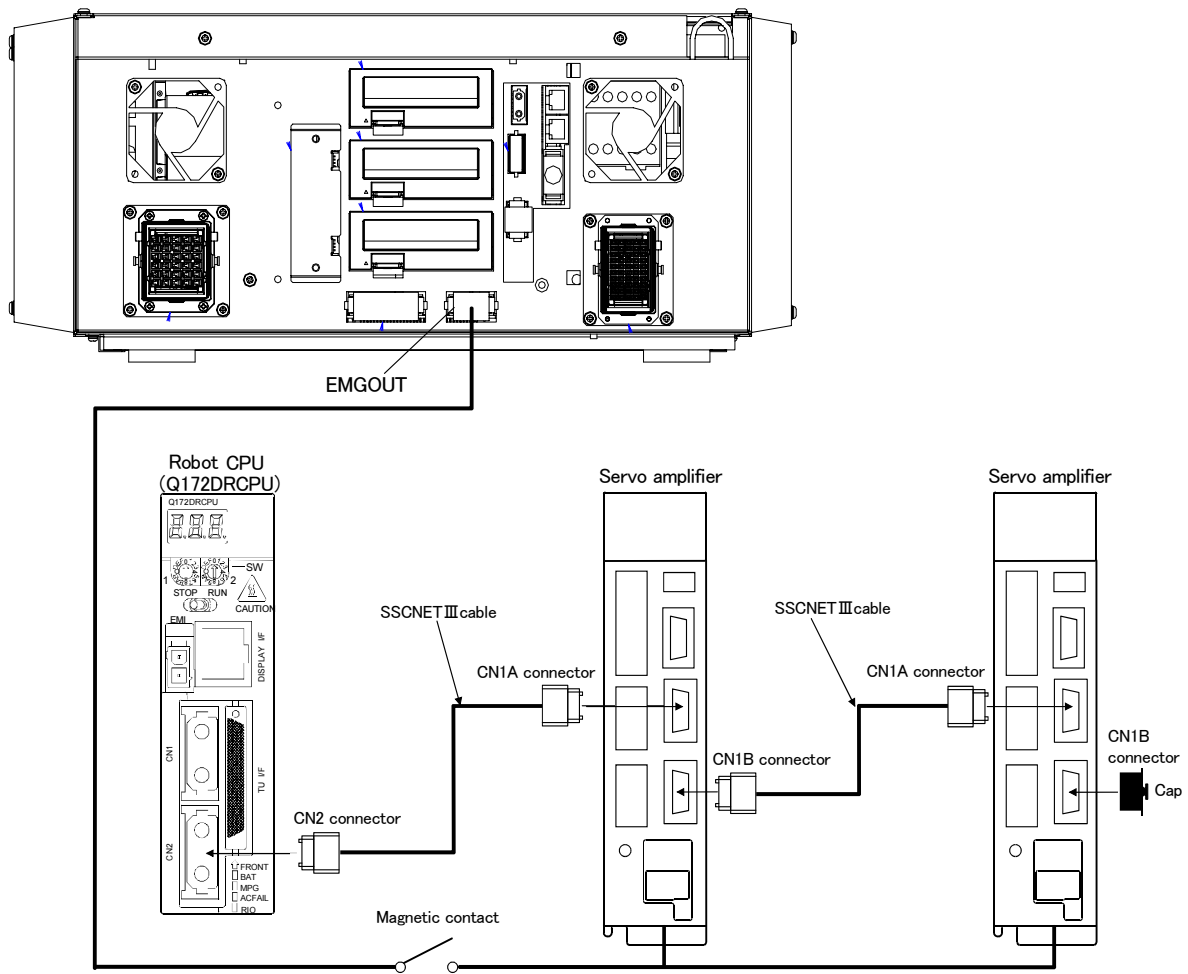
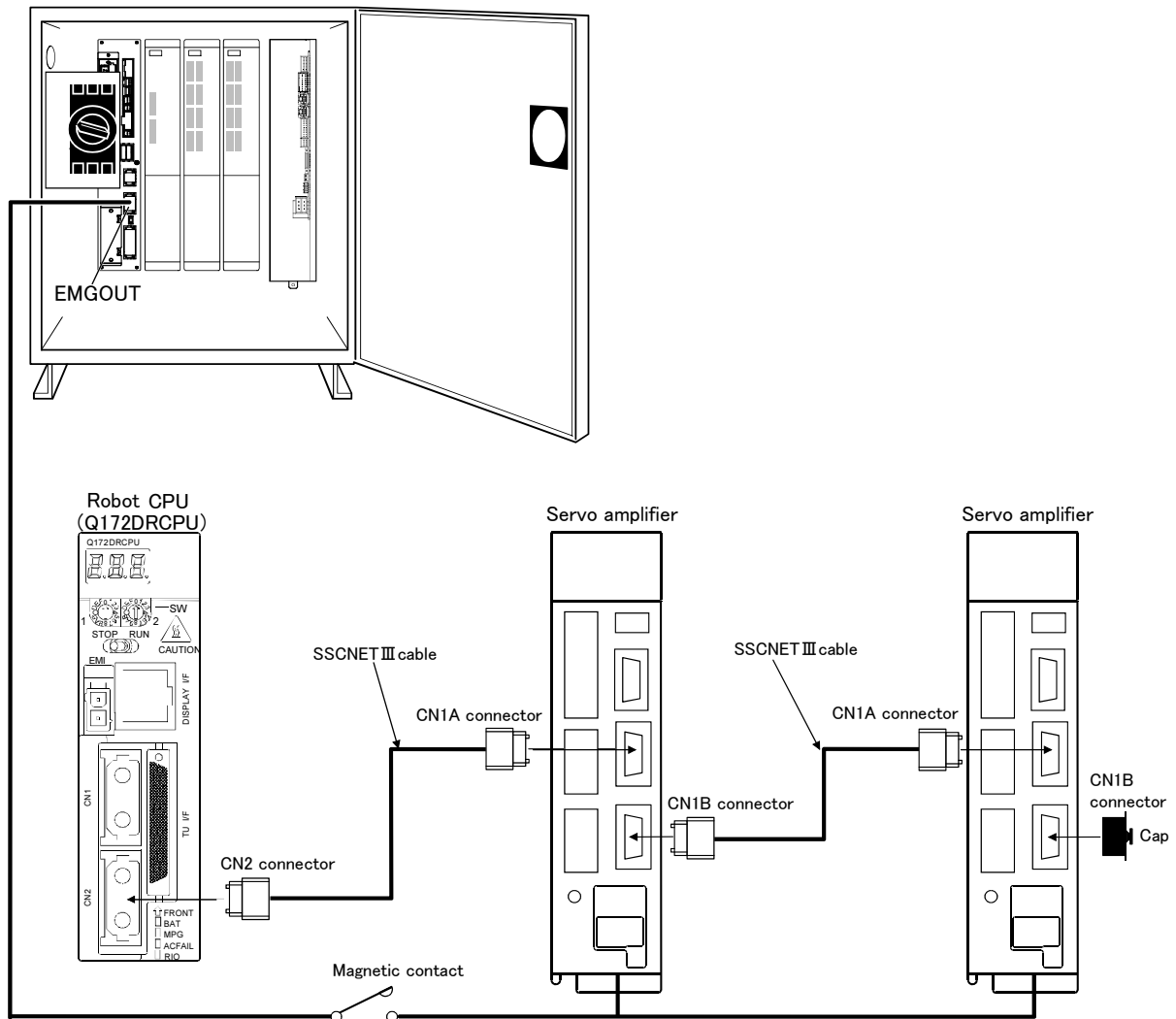

Fig.3-26 : Example of addition axis connection (DUA2-700)

<DU3-700/700M>



*It cannot communicate, if connection of CN1A and CN1B is mistaken.

Fig.3-27 : Example of addition axis connection (DU3-700/700M)

(1) Example of the installation of the noise filter

1) EMC filter (recommended)

Please install the recommendation filter shown below according to the example of connection.

1) Combination with the servo amplifier

Servo amplifier	Recommended filter (Soshin Electric)		Mass [kg]([lb])
	Model	Leakage current [mA]	
MR-J3-10B to MR-J3-100B MR-J3-10B1 to MR-J3-40B1	(Note) HF3010A-UN	5	3 (6.61)
MR-J3-250B ▪ MR-J3-350B	(Note) HF3030A-UN		5.5 (12.13)
MR-J3-500B ▪ MR-J3-700B	(Note) HF3040A-UN	1.5	6.0 (13.23)
MR-J3-11KB to MR-J3-22KB	(Note) HF3100A-UN	6.5	15 (33.07)
MR-J3-60B4 ▪ MR-J3-100B4	TF3005C-TX	5.5	6(13.23)
MR-J3-200B4 to MR-J3-700B4	TF3020C-TX		7.5(16.54)
MR-J3-11KB4	TF3030C-TX		12.5(27.56)
MR-J3-15KB4	TF3040C-TX		
MR-J3-22KB4	TF3060C-TX		

Note. A surge protector is separately required to use any of these EMC filters.

2) Connection example

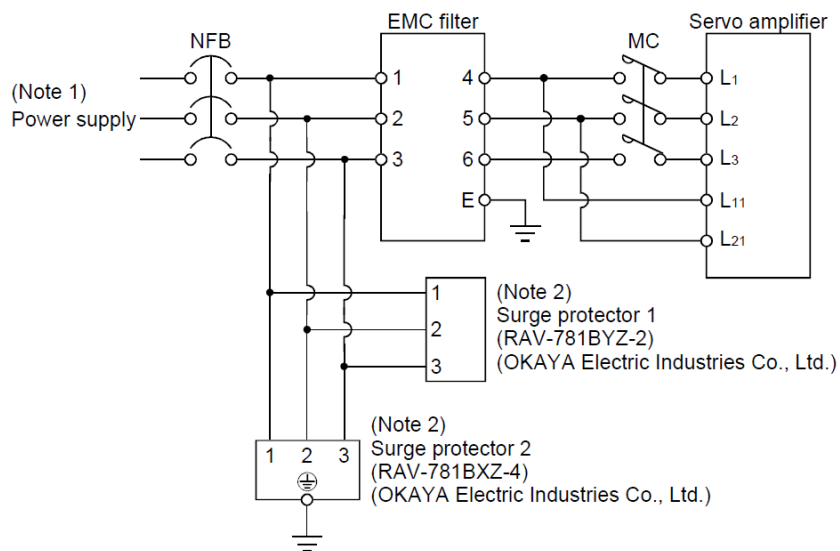

Note 1. For 1-phase 200V to 230VAC power supply, connect the power supply to L1,L2 and leave L3 open.

There is no L3 for 1-phase 100 to 120VAC power supply. Refer to section 1.3 for the power supply specification.

2. The example is when a surge protector is connected.

Fig.3-28 : Example of EMC noise filter installation

2) Line noise filter

This filter is effective in suppressing noises radiated from the power supply side and output side of the servo amplifier and also in suppressing high-frequency leakage current (zero-phase current) especially within 0.5MHz to 5MHz band.

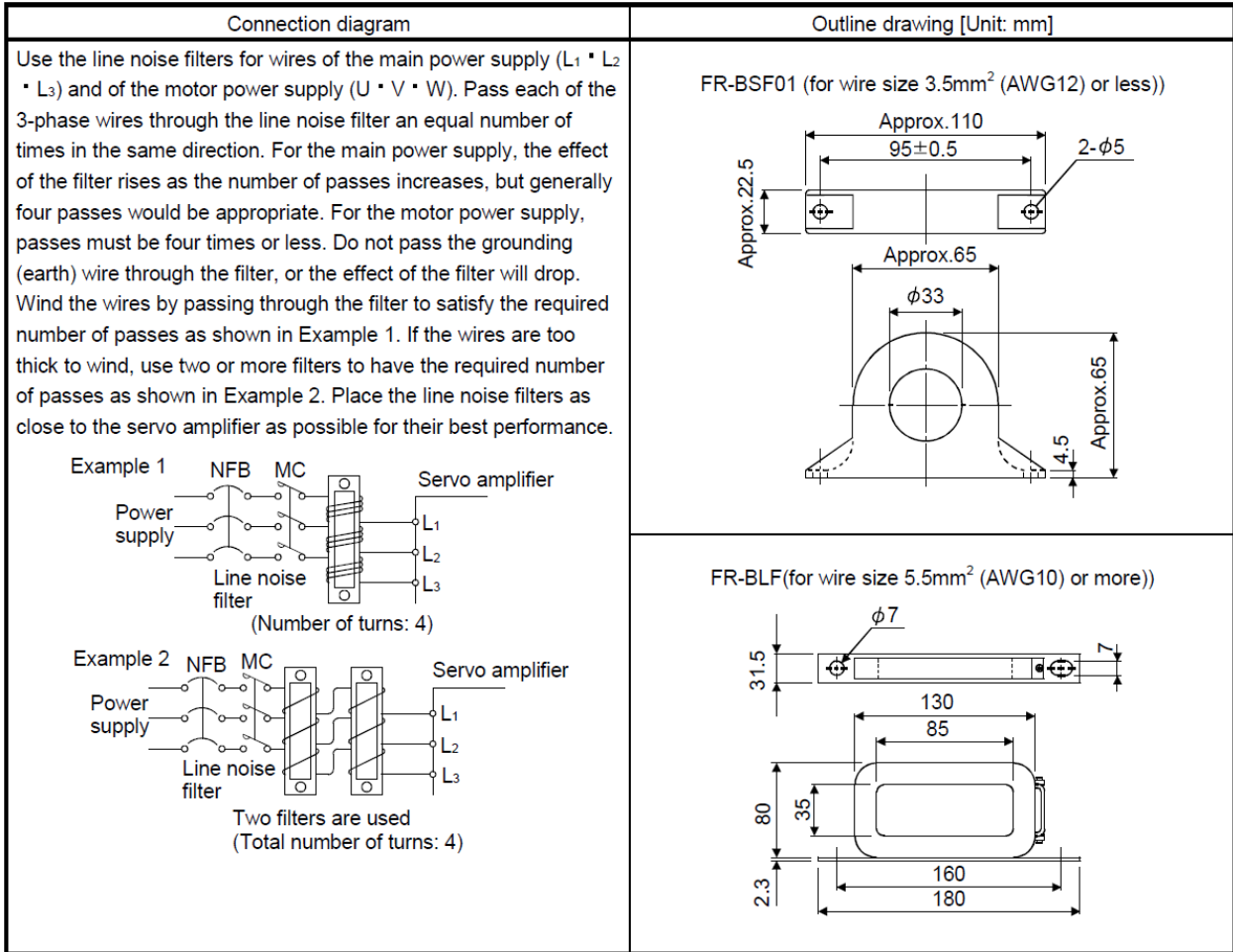

Fig.3-29 : Example of noise filter installation

3.8 Magnet contactor control connector output (AXMC) for addition axes

When an additional axis is used, the servo ON/OFF status of the additional axis can be synchronized with the servo ON/OFF status of the robot itself by using the output contact (AXMC) provided on the rear or inside of the controller and configuring a circuit so that the power to the servo amplifier for the additional axis can be turned off when this output is open.

Fig. 3-30 shows an example of its circuit, and Fig. 3-31, Fig. 3-32 show the layout drawings of the output contact (EMGOUT). When you are using an additional axis, please perform appropriate circuit connections by referring to these drawings.

Refer to the separate "Additional axis interface Instruction Manual" for details on the additional axis function.

Note1) you use the addition axis function as a user mechanism who became independent of the robot arm, please do not connect this output signal. Servo-on of the user mechanism may be unable.

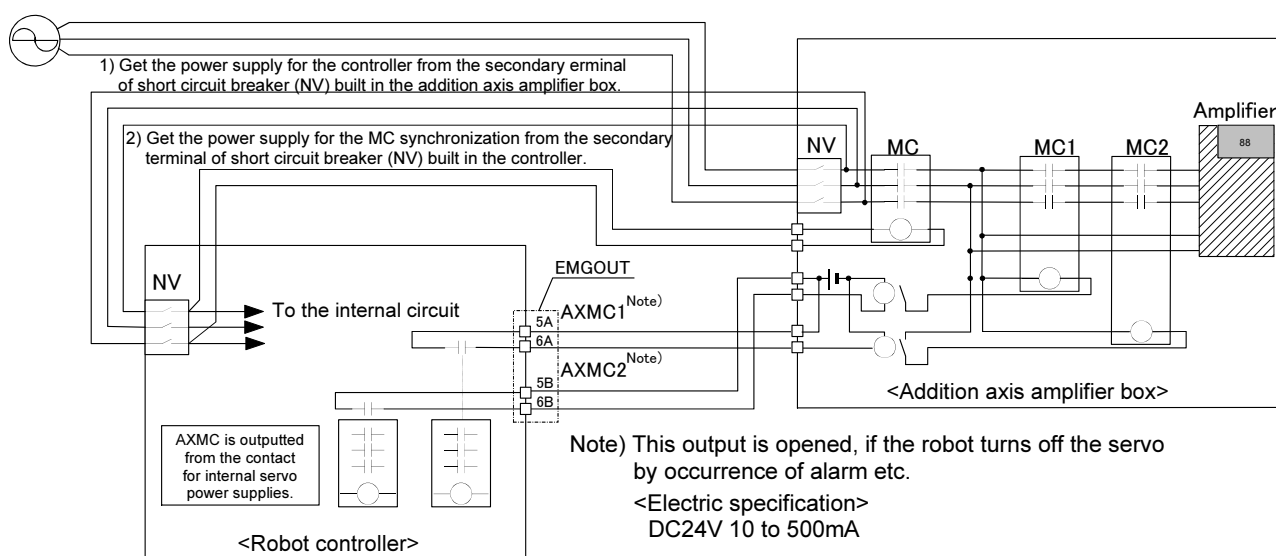

Fig.3-30 : Example of circuit for addition axes of Magnet contactor control output

<DU2A-700>

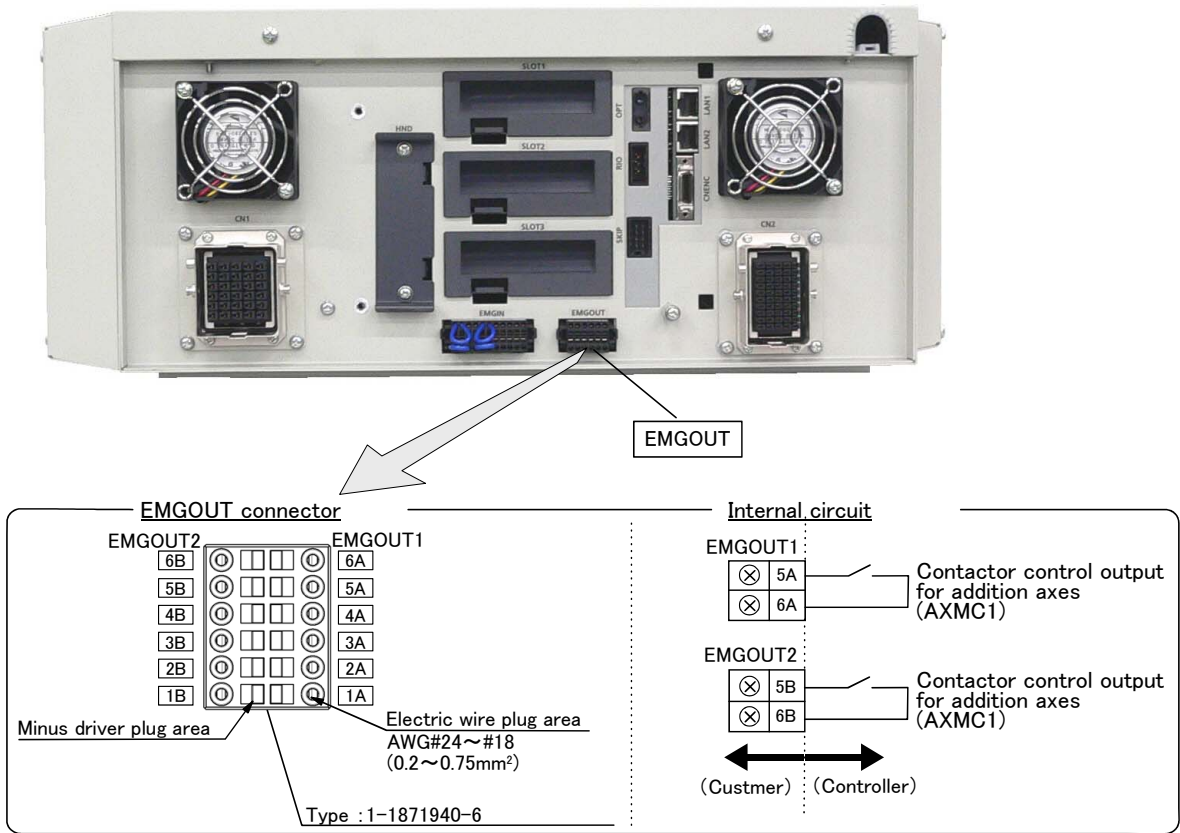

Fig.3-31 : EMGOUT connector (DU2A-700)

<DU3-700/700M>

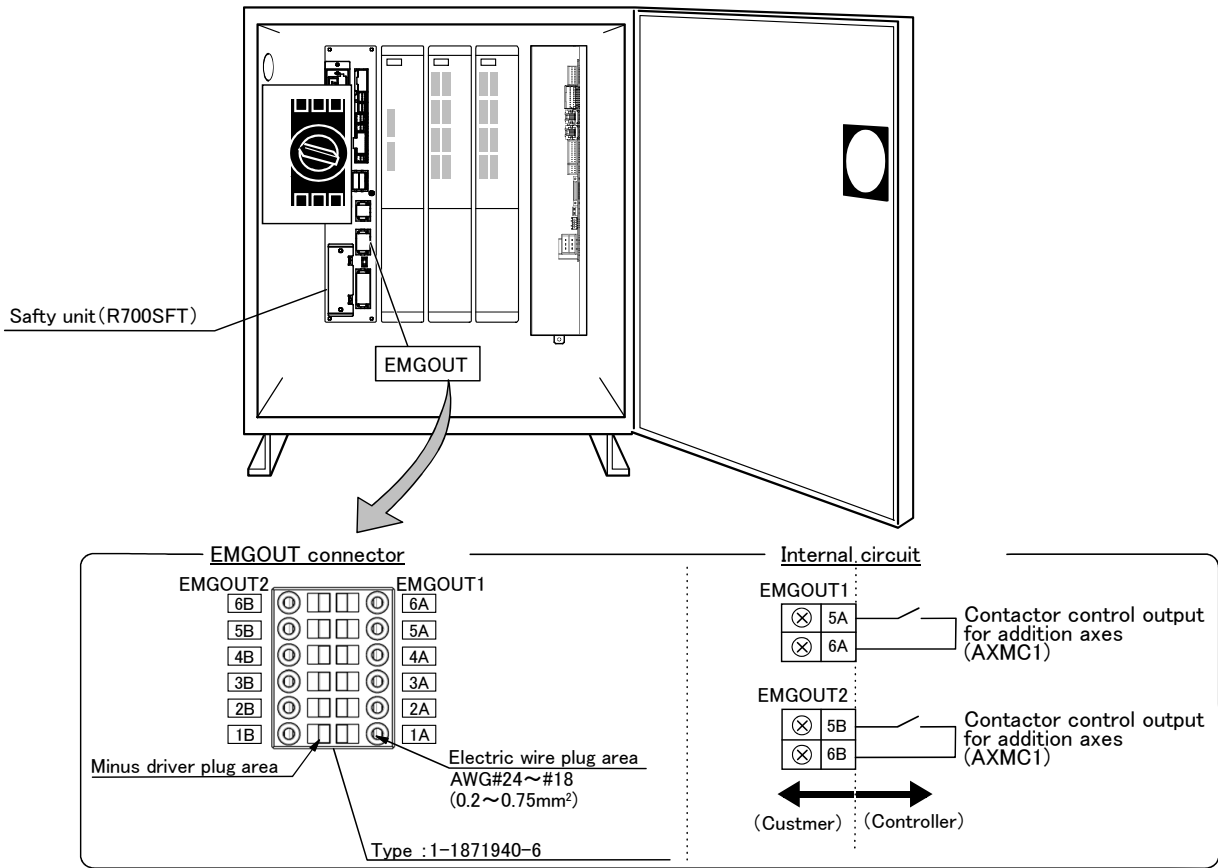

Fig.3-32 : EMGOUT connector (DU3-700/700M)

3.9 Options

■ What are options?

There are a variety of options for the robot designed to make the setting up process easier for user needs.

User installation is required for the options.

Options come in two types: "set options" and "single options".

1. Set optionsA combination of single options and parts that together, form a set for serving some purpose.
2. Single optionsThat are configured from the fewest number of required units of a part. Please choose user's purpose additionally.

(1) Teaching pendant (T/B)

- Order type: R32TB :Cable length 7m
R32TB-15 :Cable length 15m

■ Outline



This is used to create, edit and control the program, teach the operation position and for jog feed, etc.

For safety proposes, a 3-position enable switch is mounted.*1)

■ Configuration

Table 3-9 : Configuration device

Part name	Type	Qty.	Mass(kg) ^{Note1)}	Remarks
Teaching pendant	R32TB	Either one pc.	1.7	Cable length is 7m. Hand strap is attached.
	R32TB-15		2.8	Cable length is 15m. Hand strap is attached.

Note1) Mass indicates one set.

■ Specifications

Table 3-10 : Specifications

Items	Specifications	Remarks
Outline dimensions	195(W) x 292(H) x 106(D) (refer to outline drawing)	
Body color	Dark gray	
Mass	Approx. 0.9kg (only arm, excluding cable)	
Connection method	Connection with controller and square connector (24-pin)	
Interface	RS-422	
Display method	LCD method: 24 characters x 8 lines, LCD illumination: with backlight	At 8x8 font
Operation section	36 keys	

*1) <3-position enable switch>

In ISO/10218 (1992) and JIS-B8433 (1993), this is defined as an "enable device". These standards specify that the robot operation using the teaching pendant is enabled only when the "enable device" is at a specified position. With the Mitsubishi Electric industrial robot, the above "enable device" is configured of an "Enable/Disable switch" and "Deadman switch".

The 3-position deadman switch has three statuses. The following modes are entered according to the switch state.

- a) "Not pressed"The robot does not operate. *)
- b) "Pressed lightly"The robot can be operated and teaching is possible.
- c) "Pressed with force"The robot does not operate. *)

*) Operations, such as program editing and status display, other than robot operation are possible.

Safety is secured as the servo power is turned OFF simultaneously with the input of the emergency stop.

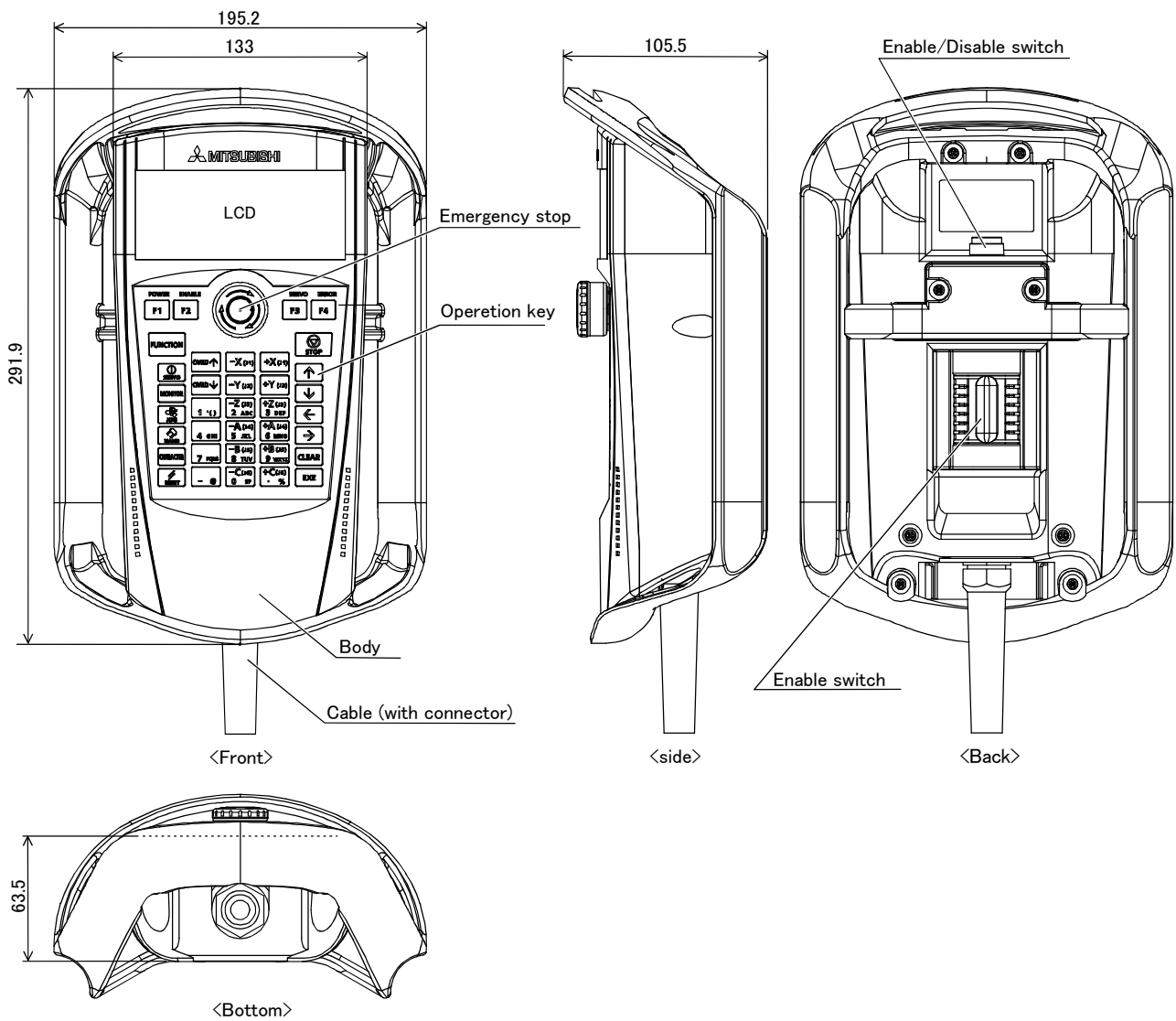

Fig.3-33 : Outside dimensions of teaching pendant

■ Installation method

The teaching pendant is connected to the T/B connector on the front of the controller.

Note) The connector may be felt hard if installation and removal of the teaching pendant or the dummy plug is repeated to the frequent.

■ Key layout and main functions

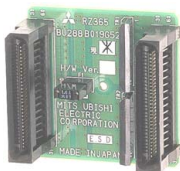

Fig.3-34 : Teaching pendant key layout and main functions

(2) Pneumatic hand interface

■ Order type: 2A-RZ365(Sink type)/2A-RZ375(Source type)

■ Outline



This interface is required to use the robot arm's hand output signals.

- Up to eight hand output points can be used with this interface.
- The eight hand input points can be used without this interface.
- The previous pneumatic hand interface can be used.

■ Configuration

Table 3-11 : Configuration device

Part name	Type	Qty.	Mass(kg) ^{Note1)}	Remarks
Pneumatic hand interface	2A-RZ365(Sink type)	Either one pc.	0.1	Output 8 points expansion.
	2A-RZ375(Source type)		0.1	

Note1) Mass indicates one set.

■ Specifications

Table 3-12 : Specifications

Item	Specification	Internal circuit	
Type	Transistor output	<div style="display: flex; flex-direction: column; align-items: center;"> <div style="text-align: center;"> <p><Sink type></p> </div> <div style="text-align: center; margin-top: 20px;"> <p><Source type></p> </div> </div> <p>* GRn = GR1 ~ GR8</p>	
No. of output points	8		
Insulation method	Photo coupler insulation		
Rated load voltage	DC24V		
Rated load voltage range	DC21.6 to 26.4VDC		
Max. current load	0.1A/ 1 point (100%)		
Current leak with power OFF	0.1mA or less		
Maximum voltage drop with power ON	DC0.9V(TYP.) ^{Note1)}		
Response time	OFF-ON		2ms or less (hardware response time)
	ON-OFF		2 ms or less (resistance load) (hardware response time)
Fuse rating	Fuses 1.0A (each one common)		
Common method	8 points, 1 common		

Note1) The drop voltage maximum value at turning on the signal.
 The available solenoid valve is that the specification of rated voltage is DC24V ± 10%

■ Installation method

This is mounted in the controller.

Attach the pneumatic hand interface (2A-RZ365/2A-RZ375) to the CNHNDOUT/CNHND connector of the hand interface relay card (2D-TZ315) securely. Refer to separate "Instruction Manual/ Controller setup, basic operation, and maintenance" for details on the installing method.

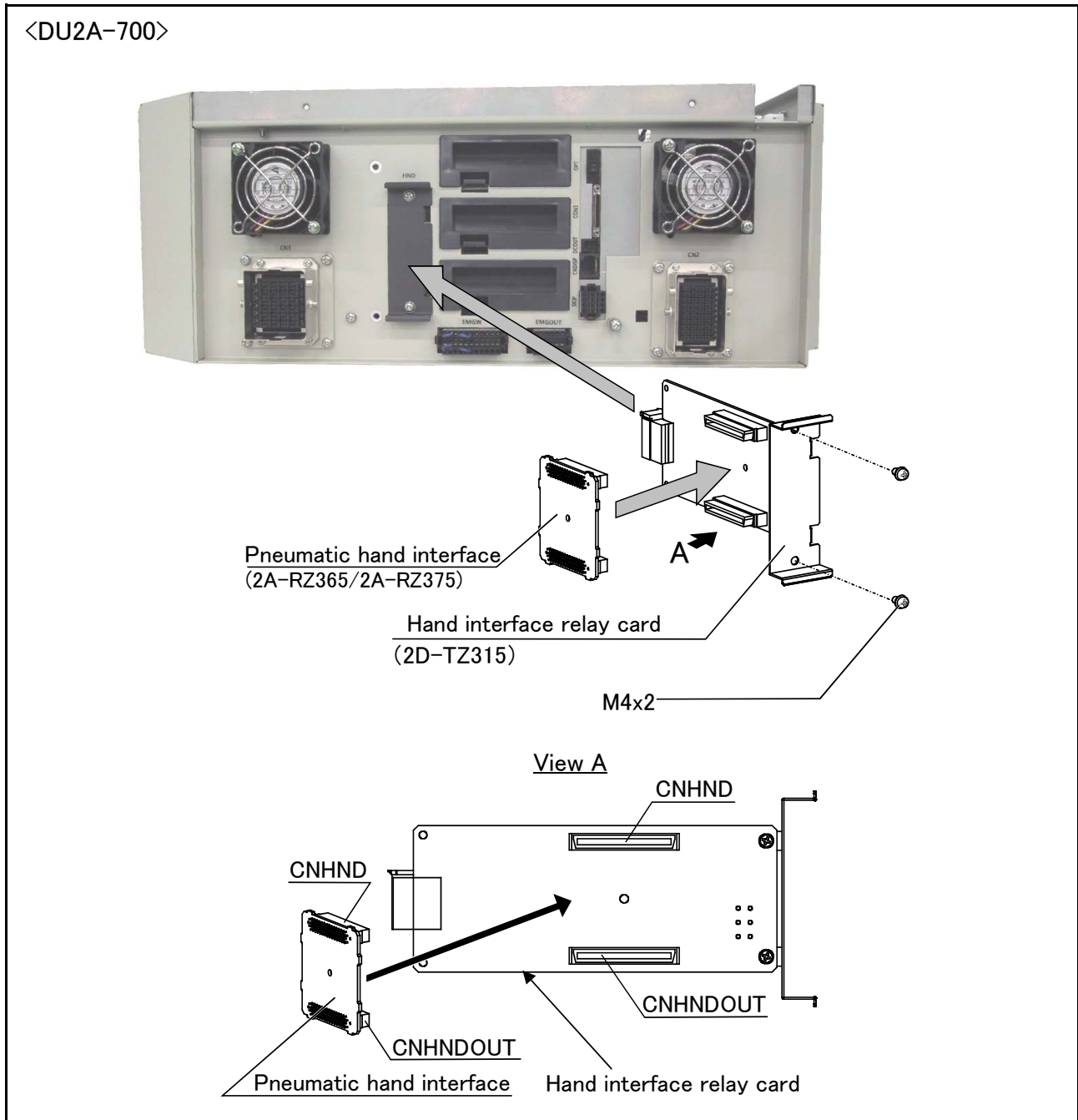

Fig.3-35 : Installation of the pneumatic hand interface (DU2A-700)

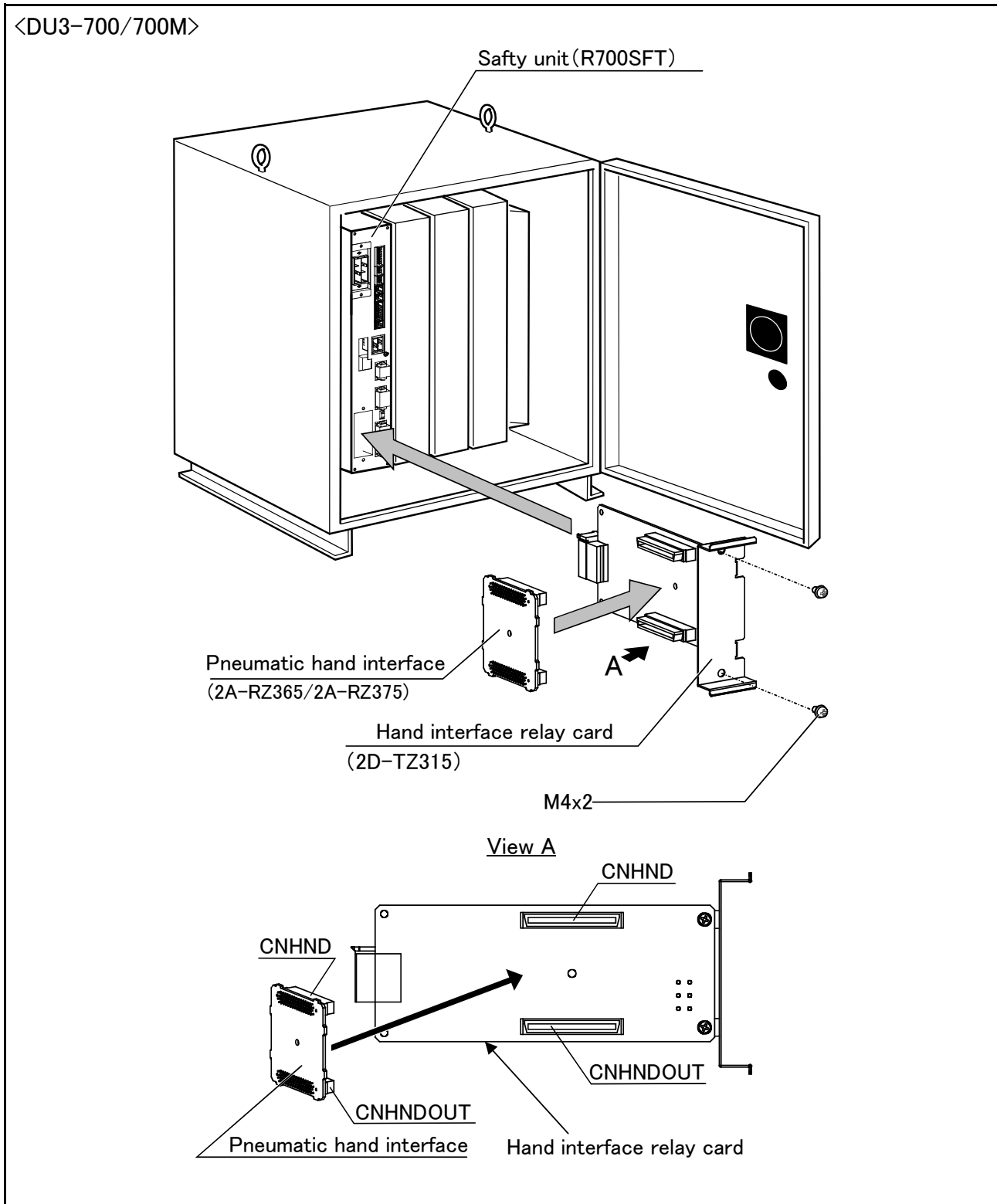

Fig.3-36 : Installation of the pneumatic hand interface (DU3-700/700M)

(3) RT ToolBox2/RT ToolBox2 mini

- Order type : ● RT ToolBox2
 *For windows CD-ROM : 3D-11C-WINE
 ● RT ToolBox2 mini
 *For windows CD-ROM : 3D-12C-WINE

■ Outline



This is handy software that fully uses the personal computer functions. It can be used in various stages from the robot specifications study (tact study, etc.) to the design support (creation and editing of programs), start up support (execution, control and debugging of program), and maintenance (remote maintenance.)

The "personal computer support software" which supports these function fully, and the "personal computer support software mini" which does not have the simulation function are available.

■ Configuration

Table 3-13 : Product configuration

Part name	Type	Medium	Mass(kg) ^{Note1)}	Remarks
RT ToolBox2	3D-11C-WINE	CD-ROM	0.2	
RT ToolBox2 mini	3D-12C-WINE	CD-ROM	0.2	

Note1) Mass indicates one set.

■ Features

- (1) Simple operation with guidance method and menu method
 The Windows standard is used for windows operation, so the controller initialization and startup operations can be carried out easily by following the instructions given on the screen. Even a beginner can easily carry out the series of operations from program creation to execution.
- (2) Increased work efficiency with ample support functions
 The work efficiency is greatly improved with the multi-window method that carries out multiple steps and displays in parallel. The renumbering function, and copy, search, syntax check and step execution are especially sufficient, and are extremely useful when editing or debugging the program.
 With the simulation function support, the program can be debugged and the tact checked before starting the machine at the site. This allows the on-site startup work efficiently to be greatly improved.
- (3) The maintenance forecast function increases the efficiency of maintenance work. Analyze the load condition while the robot is actually operating. Based on this analysis, calculate the time for maintenance, such as lubrication and belt replacement. By utilizing this information, the line stop time as well as the maintenance costs can be reduced.
- (4) The position recovery support function increases the recovery efficiency in the event of origin position displacement. This function compensates the origin settings and position data by just reproducing several previous teaching points when hand and/or arm displacement occurs, when replacing the motor and the belts, or when reloading the robot. This function can reduce the time required for recovery.

■ Functions

Table 3-14 : Functions

Function		Functional existence ^{Note1)}		Details
Compatible model		○	○	Personal computer running Microsoft Windows2000/XP/Vista.
Program editing functions	Editing functions	○	○	<ul style="list-style-type: none"> ▪ MELFA BASIC V language compatible ▪ Multiple editing screen simultaneously display ▪ Command input, comment writing ▪ Position data editing ▪ File operation (writing to controller, floppy disk, personal computer) ▪ Search and replace function (using characters, line Nos., labels) ▪ Copy, cut, paste, insert (per character, line), undo (per command statement, position conversion) ▪ Line No. automatic generation, renumbering ▪ Batch syntax check ▪ Command template ▪ Position conversion batch editing ▪ Position variable template ▪ Print, print preview
	Control functions	○	○	<ul style="list-style-type: none"> ▪ Program file control (list, copy, movement, delete, content comparison, name change, protect)
	Debugging functions	○	○	<ul style="list-style-type: none"> ▪ Direct editing of program in controller ▪ Confirmation of robot program operation (step execution, direct execution)
Simulation function		○	×	<ul style="list-style-type: none"> ▪ Off-line simulation of robot program operation using CG (computer graphics) ▪ Tact time calculation
Monitor functions		○	○	<ul style="list-style-type: none"> ▪ Robot operation monitor (robot operation state, stop signal, error monitor, program monitor (execution program, variables), general-purpose input/output signals (forced output possible), dedicated input/output signals, operation confirmation (operation range, current position, hand, etc.)) ▪ Operation monitor (working time statistics, production information, robot version) ▪ Servo monitor (load)
Maintenance function		○	○	<ul style="list-style-type: none"> ▪ Parameter setting ▪ Batch, divided backup

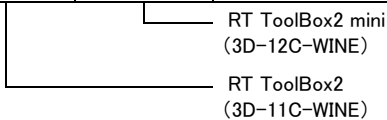

Note1) The functions included with the RT ToolBox2 and the RT ToolBox2 mini are shown below.

○ : Function provided × : Function not provided

(4) Instruction Manual(bound edition)

■ Order type : ● 5S-QB00-PE01 (RV-6SQ/6SQL series)

■ Outline



This is a printed version of the CD-ROM (instruction manual) supplied with this product.

■ Configuration

Table 3-15 : Product configuration(RV-6SQ/6SQL series)

Name	Type	Mass(kg) ^{Note1)}	Specifications
Instruction Manual	5S-QB00-PE01	2.4	
Safety Manual	BFP-A8006	-	Items relating to safety in handling the robot
Standard Specifications	BFP-A8690	-	Specification of the robot arm and controller
Robot Arm Setup & Maintenance	BFP-A8691	-	Installation method of the robot arm, jog operation, and maintenance and inspection procedures
Controller Setup, Basic Operation and Maintenance	BFP-A8688	-	Installation method of the controller, basic operation, and maintenance and inspection procedures
Detailed Explanation of Functions and Operations	BFP-A8586	-	Functions of the controller and T/B, operation method, and explanation of MELFA-BASIC V
Troubleshooting	BFP-A8588	-	Causes of errors occurred and their countermeasures
Additional axis function	BFP-A8663	-	Function of the additional axis, operation method.
Tracking Function Manual	BFP-A8664	-	Function of the Tracking, operation method.
Extended Function Instruction Manual	BFP-A8787	-	Function of the Extended, operation method.

Note1) Mass indicates one set.

3.10 Maintenance parts

The consumable parts used in the controller are shown in [Table 3-16](#). Purchase these parts from your dealer when required. Some Mitsubishi-designated parts differ from the maker's standard parts. Thus, confirm the part name, robot arm and controller serial No. and purchase the parts from your dealer.

Table 3-16 : Controller consumable parts list

No.	Name	Type ^{Note1)}	Qty.	Usage place	Supplier
CR2QA-700 controller					
1	Lithium battery	Q6BAT	1	Robot CPU unit	Mitsubishi Electric System Service;Co.,Ltd
2	Filter		1	Front of the controller	
CR3Q-700 controller					
1	Lithium battery	Q6BAT	1	Robot CPU unit	Mitsubishi Electric System Service;Co.,Ltd
2	Fan (40 square)		5	Amplifier unit Converter unit	
3	Fan (90 square)		1	Control unit	
4	Filter		1	Controller rear	

Note1) Confirm the robot arm serial No., and contact the dealer or service branch of Mitsubishi Electric Co., for the type.

4 Software

4.1 List of commands

The available new functions in MELFA-BASIC V are given in Table 4-1.

Table 4-1 : List of MELFA-BASIC V commands

Type	Class	Function	Input format (example)
Position and operation control	Joint interpolation	Moves to the designated position with joint interpolation.	Mov P1
	Linear interpolation	Moves to the designated position with linear interpolation.	Mvs P1
	Circular interpolation	Moves along a designated arc (start point → passing point → start point (end point)) with 3-dimensional circular interpolation (360 degrees).	Mvc P1,P2,P1
		Moves along a designated arc (start point → passing point → end point) with 3-dimensional circular interpolation.	Mvr P1,P2,P3
		Moves along the arc on the opposite side of a designated arc (start point → reference point → end point) with 3-dimensional circular interpolation.	Mvr2 P1,P9,P3
		Moves along a set arc (start point → end point) with 3-dimensional circular interpolation.	Mvr3 P1,P9,P3
		Speed designation	Designates the speed for various interpolation operations with a percentage (0.1% unit).
	Designate the speed for joint interpolation operation with a percentage (0.1% unit).		JOvrd 100
	Designates the speed for linear and circular interpolation with a numerical value (mm/s unit).		Spd 123.5
	Designates the acceleration/deceleration time as a percentage in respect to the predetermined maximum acceleration/deceleration. (1% unit)		Accel 50,80
	Automatically adjusts the acceleration/deceleration according to the parameter setting value.		Oadl ON
	sets the hand and work conditions for automatic adjustment of the acceleration/deceleration.		LoadsetT 1,1
	Operation		Performance of movement is upgraded corresponding to the application.
		Adds a process unconditionally to the operation.	Wth
		Adds a process conditionally to the operation.	Wthif
		Designates smooth operation.	Cnt 1,100,200
		Designates the positioning completion conditions with a No. of pulses.	Fine 200
		Designates the positioning completion conditions with a joint interpolation.	Fine 0.5, J, 2
		Designates the positioning completion conditions with a distance in a straight line	Fine 1, P
		Turns the servo power ON/OFF for all axes.	Servo OFF
		Limits the operation of each axis so that the designated torque is not exceeded.	Torq 4,10
	Position control	Designates the base conversion data.	Base P1
		Designates the tool conversion data.	Tool P1
	Float control	The robot arm rigidity is lowered and softened. (XYZ coordinate system)	Cmp Pos ,&B00000011
		The robot arm rigidity is lowered and softened. (JOINT coordinate system)	Cmp Jnt ,&B00000011
		The robot arm rigidity is lowered and softened. (TOOL coordinate system)	Cmp Tool ,&B00000011
		The robot arm rigidity is returned to the normal state.	Cmp Off
		The robot arm rigidity is designated.	Cmpg 1.0,1.0,1.0,1.0,1.0,1.0,1.0,1.0
	Pallet	Defines the pallet.	Def Plt 1,P1,P2,P3,P4,5,3,1
		Operates the pallet grid point position.	Plt 1,M1
	Singular point passage	Move to a specified position using linear interpolation passing through a singular point.	Mvs P1 TYPE 0,2

Type	Class	Function	Input format (example)
Program control	Branching	Branches unconditionally to the designated place.	GoTo 120
		Branches according to the designated conditions.	If M1=1 Then GoTo *L100 Else GoTo 20 End If
		Repeats until the designated end conditions are satisfied.	For M1=1 TO 10 Next M1
		Repeats while the designated conditions are satisfied.	While M1<10 Wend
		Branches corresponding to the designated expression value.	On M1 GoTo *La1, *Lb2, *Lc3
		Executes program block corresponding to the designated expression value..	Select Case 1 Break Case 2 Break End Select
		Moves the program process to the next line.	Skip
	Impact detection	Set to enable/disable the impact detection.	CoLChk ON/OFF
		Set the detection level of the impact detection.	CoLvl 100,80,.....
	Subroutine	Executes the designated subroutine. (Within program)	GoSub *L200
		Returns from the subroutine.	Return
		Executes the designated program.	CallP "P10",M1,P1
		Defines the program argument executed with the CALLP command.	FPrm M10,P10
		Executes the subroutine corresponding to the designated expression value.	On M1 GoSub *La1, *Lb2, *Lc3
	Interrupt	Defines the interrupt conditions and process.	Def Act 1, M1=1 GoTo *L100
		Enables/disables the interrupt.	Act 1=1
		Defines the start line of the program to be executed when an interrupt is generated from the communication line.	On Com(1) GoSub *L100
		Enables the interrupt from the communication line.	Com(1) On
		Disables the interrupt from the communication line.	Com(1) Off
		Stops the interrupt from the communication line.	Com(1) Stop
	Wait	Designates the wait time, and the output signal pulse output time. (0.01s unit)	Dly 0.5
		Waits until the variable becomes the designated value.	Wait M_In(1)=1
	Stop	Stops the program execution.	Hlt
		Generates an error. During program execution, continue, stop or servo OFF can be designated.	Error 9000
	End	Ends the program execution.	End
	Hand	Hand open	Opens the designated hand.
Hand close		Closes the designated hand.	HClose 1
Input/output	Assignment	Defines the input/output variables.	Def IO PORT1=BIT,0
	Input	Retrieves the general-purpose input signal.	M1=M_In(1)
	Output	Calls out the general-purpose output signal.	M_Out(1)=0
Parallel execution	Mechanism designation	Acquires the mechanism with the designated mechanism No.	GetM 1
		Releases the mechanism with the designated mechanism No.	RelM 1
	Selection	Selects the designated program for the designated slot.	XLoad 2,"P102"
	Start/stop	Carries out parallel execution of the designated program.	XRun 3,"100",0
		Stops parallel execution of the designated program.	XStp 3
	Returns the designated program's execution line to the head and enters the program selection enabled state.	XRst 3	

Type	Class	Function	Input format (example)
Others	Definition	Defines the integer type or real number type variable.	Def Inte KAISUU
		Defines the character string variable.	Def Char MESSAGE
		Defines the layout variable. (Up to 3-dimensional possible)	Dim PDATA(2,3)
		Defines the joint variable.	Def Jnt TAIHI
		Defines the position variable.	Def Pos TORU
		Defines the function.	Def FN TASU(A,B)=A+B
	Clear	Clears the general-purpose output signal, variables in program, variables between programs, etc.	Clr 1
	File	Opens a file.	Open "COM1:" AS #1
		Closes a file.	Close #1
		Inputs data from a file.	Input# 1,M1
		Outputs data to a file.	Print# 1,M1
	Comment	Describes a comment.	Rem "ABC"
	Label	Indicates the branching destination.	*SUB1

4.2 List of parameters

show the main parameter in the [Table 4-2](#).

Table 4-2 : List of parameters

Parameter		Details
Standard tool coordinates.	MEXTL	Set the default value for the tool data. Unit: mm or deg.
Standard base coordinates	MEXBS	Set the relation of the world coordinate system and robot coordinate system. Unit: mm or deg.
XYZ operation range	MEPAR	Designate the overrun limit value for the world coordinate system.
JOINT operation range	MEJAR	Set the overrun limit value for each joint axis.
Free plane limit		This is the overrun limit set with the free plane. Create a plane with the three coordinates x1, y1, z1 to x3, y3, z3, and set the outer side of the plane as the outside operation range (error). The following three types of parameters are used.
	SFC1P : SFC8P	Eight types of free plane limits can be set in SFC1P to SFC8P. There are nine elements, set in the order of x1, y1, z1, x2, y2, z2, x3, y3, z3.
	SFC1ME : SFC8ME	Designate which mechanism to use eight types of set free plane limits. The mechanism No. to use is set with 1 to 3.
	SFC1AT : SFC8AT	Set the validity of the eight types of set free plane limits. (Valid 1/Valid 2/invalid = 1/-1/0)
User-defined area		An area (cube) defined with two XYZ coordinate points can be designated and that area set as the outside operation range. Furthermore, a signal can be output when the axis enters that area. Up to 32 types of area can be designated.
	AREA1CS : AREA32CS	Specify the coordinate system of the user definition area *. 0: Base coordinate system (conventional compatibility) 1: Robot coordinate system
	AREA1P1 : AREA32P1	Designated the 1st point of the area. There are eight elements, set in the order of x, y, z, a, b, c, L1, L2. (L1 and L2 are the additional axes.)
	AREA1P2 : AREA32P2	Designated the 2nd point of the area. There are eight elements, set in the order of x, y, z, a, b, c, L1, L2. (L1 and L2 are the additional axes.)
	AREA1ME : AREA32ME	Designate which mechanism to use the 32 types of set area. The mechanism No. to use is set with 1 to 3.
	AREA1AT : AREA32AT	Designate the area check type. (Invalid/zone/interference = 0/1/2) Zone: The dedicated output signal USRAREA turns ON. Interference: An error occurs..
Automatic return setting	RETPATH	Set to restart the program after returning to the interrupt position when resuming operation after an interruption.
Buzzer ON/OFF	BZR	Designate whether to the turn buzzer ON or OFF.
Jog setting	JOGJSP	Designate the joint jog and step operation speed. (Set dimension H/L amount, max. override.)
	JOGPSP	Designate the linear jog and step operation speed. (Set dimension H/L amount, max. override.)
Jog speed limit value	JOGSPMX	Limit the operation speed during the teaching mode. Max. 250[mm/s]

Parameter		Details
Hand type	HANDTYPE	Set the hand type of the single/double solenoid, and the signal No. (Single/double = S/D) Set the signal No. after the hand type. Example) D900
Stop input B contact designation	INB	Change the dedicated input (stop) between the A contact and B contact.
User-designated origin	USERORG	Designate the user-designated origin position.
Program selection memory	SLOTON	Select the program selected previously when initializing the slot. The non-selected state will be entered when not set.
Communication setting	CBAU232	Set the baud rate.
	CLEN232	Set the character length.
	CPRTY232	Set the parity.
	CSTOP232	Set the stop bit.
	CTERM232	Set the end code.
Slot table	SLT1 : SLT32	Make settings (program name, operation type, order of priority, etc.) for each slot during slot initialization.
No. of multi-tasks	TASKMAX	Designate the No. of programs to be executed simultaneously. (Max. 32)
Select the function of singular point adjacent alarm	MESNGLSW	Designate the valid/invalid of the singular point adjacent alarm. (Invalid/Valid = 0/1) When this parameter is set up "VALID", this warning sound is buzzing even if parameter: BZR (buzzer ON/OFF) is set up "OFF".
Display language.	LNG	Change the language to display on the LCD display of teaching pendant.

5 Instruction Manual

5.1 The details of each instruction manuals

The contents and purposes of the documents enclosed with this product are shown below. Use these documents according to the application.

Instruction manuals enclosed in dashed lines in the list below are for optional products.

For special specifications, a separate instruction manual describing the special section may be enclosed.

Safety Manual	Explains the common precautions and safety measures to be taken for robot handling, system design and manufacture to ensure safety of the operators involved with the robot.
Standard Specifications or special Specifications	Explains the product's standard specifications, factory-set special specifications, option configuration and maintenance parts, etc. Precautions for safety and technology, when incorporating the robot, are also explained.
Robot Arm Setup & Maintenance	Explains the procedures required to operate the robot arm (unpacking, transportation, installation, confirmation of operation), and the maintenance and inspection procedures.
Controller Setup, Basic Operation and Maintenance	Explains the procedures required to operate the controller (unpacking, transportation, installation, confirmation of operation), basic operation from creating the program to automatic operation, and the maintenance and inspection procedures.
Detailed Explanation of Functions and Operations	Explains details on the functions and operations such as each function and operation, commands used in the program, connection with the external input/output device, and parameters, etc.
Troubleshooting	Explains the causes and remedies to be taken when an error occurs. Explanations are given for each error No.
Additional axis function	Explains the specifications, functions and operations of the additional axis control.
Tracking Function Manual	Explains the control function and specifications of conveyor tracking

Extended Function Instruction Manual

Explains the detailed description of data configuration of shared memory, monitoring, and operating procedures, about the PLC (CRnD-700 series controller).

6 Safety

6.1 Safety

Measures to be taken regarding safety of the industrial robot are specified in the "Labor Safety and Sanitation Rules". Always follow these rules when using the robot to ensure safety.

6.1.1 Self-diagnosis stop functions

This robot has the self-diagnosis stop functions shown in [Table 6-1](#) and the stop functions shown in [Table 6-2](#) for safe use.

Table 6-1 : Self-diagnosis stop functions

No.	Function		Details	Remarks
1	Overload protection function		Activates when the total servo current time exceeds the specified value.	The drive circuit is shut off. The robot stops, and an alarm displays.
2	Overcurrent diagnosis function		Activates when an overcurrent flows to the motor circuit.	The drive circuit is shut off. The robot stops, and an alarm displays.
3	Encoder disconnection diagnosis function		Activates when the encoder cable is disconnected.	The drive circuit is shut off. The robot stops, and an alarm displays.
4	Deflection over diagnosis function		Activates when an error occurs between the command value and actual position, and the error exceeds the specified amount.	The drive circuit is shut off. The robot stops, and an alarm displays.
5	AC power voltage drop diagnosis function		Activates when the AC power voltage drops below the specified value.	The drive circuit is shut off. The robot stops, and an alarm displays.
6	CPU error detection function		Activates when an error occurs in the CPU.	The drive circuit is shut off. The robot stops, and an alarm displays.
7	Overrun prevention function	Software limit detection	This is the limit provided by the software to enable operation only in the operation range.	The drive circuit is shut off. The robot stops, and an alarm displays.
		Mechanical stopper	This is the mechanical stopper provided outside the software.	The robot mechanically stops, and function 1 or 2 activates.

Table 6-2 : List of stop functions

Stop function	Operation panel	Teaching pendant	External input	Details
Emergency stop	○	○	○	This is the stop with the highest degree of emergency. The servo power is shut off, and the mechanical brakes (all axes) activate to stop the robot. To recover, reset the alarm, and turn the servo ON with the servo ON command.
Stop	○	○	○	This is a stop operation with a high degree of emergency. The robot immediately decelerates and stops. Note that the servo power is not shut off. Use this when using the collision evasion sensor, etc.

6.1.2 External input/output signals that can be used for safety protection measures

Table 6-3 : External input/output signals that can be used for safety protection measures

Signal	Connection point	Parameter	Functions	Usage method			
Input	External emergency stop	Terminal (EMG IN)	-	This servo power is shut off, and the robot stops immediately.	Externally installed emergency stop switch. Door switch on safety protection fence. Stopping at high-level error occurrence.		
	Door switch					-	The door switch of the safe protection fence
	Enabling device input						Enabling device. The safety switch during teaching work
	Stop	Sequencer unit	STOP	The program execution is stopped, and the robot stops. The servo power is not shut off.	The robot is stopped when a peripheral device fault occurs. The servo power is not shut off.		
	Servo OFF		SRVOFF	The servo power can be shut off.	The robot is stopped when a peripheral device fault occurs. The servo power is not shut off.		
	Automatic operation enable		AUTOENA	Disables automatic operation when inactive.	Door switch on safety protection fence		
Output	In servo ON	Sequencer unit	SRVON	The servo power ON/OFF state is output.	The servo power ON/OFF state is shown and alerted with the display lamps.		
	Waiting		STOP	Outputs that the robot is temporarily stopped.	The temporary stop state is shown and alerted with the display lamps.		
	In alarm		ERRRESET	Outputs when an alarm occurs in the robot.	The alarm state is shown and alerted with the display lamps.		

[Caution] The external emergency stop input is prepared as a b contact for safety proposes. Thus, if the emergency stop input circuit is opened when the robot is started up, the robot will not operate. Refer to Page 100, "6.1.7 Examples of safety measures" for details.

6.1.3 Precautions for using robot

The safety measures for using the robot are specified in the "Labor Safety and Sanitation Rules". An outline of the rules is given below.

(1) Robot installation

- Secure sufficient work space required to safely perform work such as teaching and maintenance related to the robot.
- Install the controller outside the robot's motion space. (If a safety fence is provided, install outside the fence.)
- Install the controller where the entire robot operation can be viewed.
- Install display lamps, etc., to indicate the robot's operation state.
- Securely fix the robot arm onto the fixing table with the designated bolts.

(2) Prevention of contact with operator

- Install a safety fence or enclosure so that the operator cannot easily enter the robot's motion space.
- Install an interlock function that will stop the robot if the safety fence or enclosure door is opened.

(3) Work procedures

- Create and observe work procedures for the robot teaching, operation, inspection and emergencies.
- Create hand signals to be followed when several operators are working together.
- Create displays such as "Teaching in Progress" and "Inspection in Progress" to be put up when an operator is in the robot's motion space so that other operators will not operate the operation panel (controller, control panel).

(4) Training

- Train the operators about the operations, maintenance and safety required for the robot work.
- Only trained and registered operators must operate the robot.
Participation in the "Special training for industrial robots" sponsored by the Labor Safety and Sanitation Committee, etc., is recommended for safety training.

(5) Daily inspection and periodic inspection

- Always inspect the robot before starting daily operations and confirm that there are no abnormalities.
- Set the periodic inspection standards in view of the robot's ambient environment and operation frequency, and perform periodic inspections.
- Make records when periodic inspections and repairs have been done, and store the records for three or more years.

6.1.4 Safety measures for automatic operation

- (1) Install safety fences so that operators will not enter the operation area during operation and indicate that automatic operation is in progress with lamps, etc.
- (2) Create signals to be given when starting operation, assign a person to give the signal, and make sure that the operator follows the signals.

6.1.5 Safety measures for teaching

Observe the following measures when teaching, etc., in the robot's operation range.

- (1) Specify and follow items such as procedures related to teaching work, etc.
- (2) Take measures so that operation can be stopped immediately in case of trouble, and measures so that operation can be restarted.
- (3) Take measures with the robot start switch, etc., to indicate that teaching work is being done.
- (4) Always inspect that stop functions such as the emergency stop device before starting the work.
- (5) Immediately stop the work when trouble occurs, and correct the trouble.
- (6) Take measures so that the work supervisor can immediately stop the robot operation when trouble occurs.
- (7) The teaching operator must have completed special training regarding safety. (Training regarding industrial robots and work methods, etc.)
- (8) Create signals to be used when several operators are working together.

6.1.6 Safety measures for maintenance and inspections, etc.

Turn the power OFF and take measures to prevent operators other than the relevant operator from pressing the start switch when performing inspections, repairs, adjustments, cleaning or oiling.

If operation is required, take measures to prevent hazards caused by unintentional or mistaken operations.

- (1) Specify and follow items such as procedures related to maintenance work, etc.
- (2) Take measures so that operation can be stopped immediately in case of trouble, and measures so that operation can be restarted.
- (3) Take measures with the robot start switch, etc., to indicate that work is being done.
- (4) Take measures so that the work supervisor can immediately stop the robot operation when trouble occurs.
- (5) The operator must have completed special training regarding safety. (Training regarding industrial robots and work methods, etc.)
- (6) Create signals to be used when several operators are working together.

6.1.7 Examples of safety measures

Two emergency-stop input circuits are prepared on the user wiring terminal block of the controller. Create a circuit as shown below for safety measures. In addition, the figure shows the normal state which is not in the emergency stop state.

[Caution] Since we have omitted the information in part because of explanation, there is the section different from the product. Also refer to Page 104, "(1) External emergency stop connection [supplementary explanation]" and Page 63, "3.6.1 Connection of the external emergency stop".

[Note] In the emergency-stop related wiring by the customer, if the coil (is not the contact points) of the relay prepared by the customer is connected to the controller, please be sure to implement the measure against the noise by the customer in the coil section. And, please also take the lifetime of noise suppression parts into consideration.

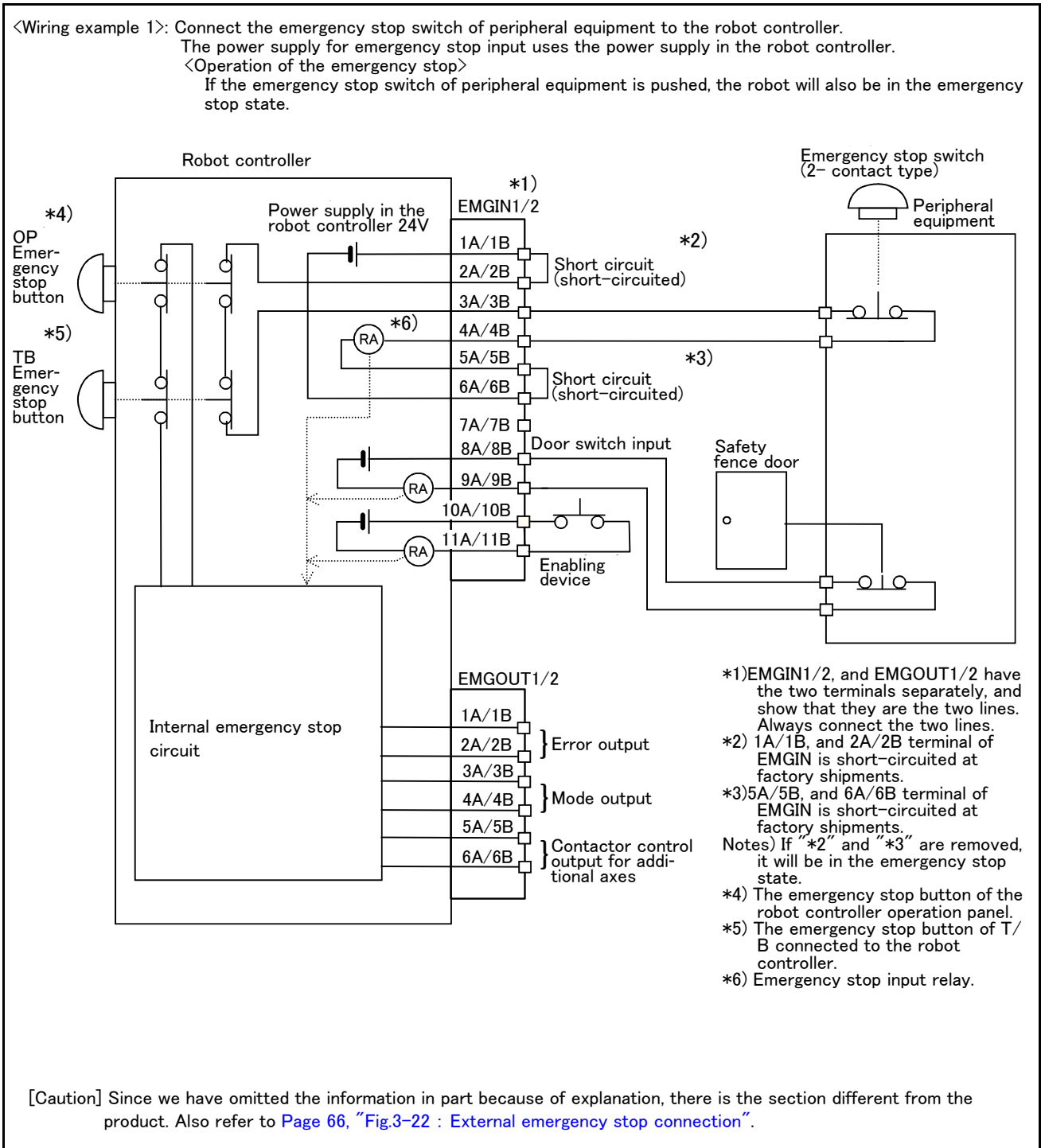
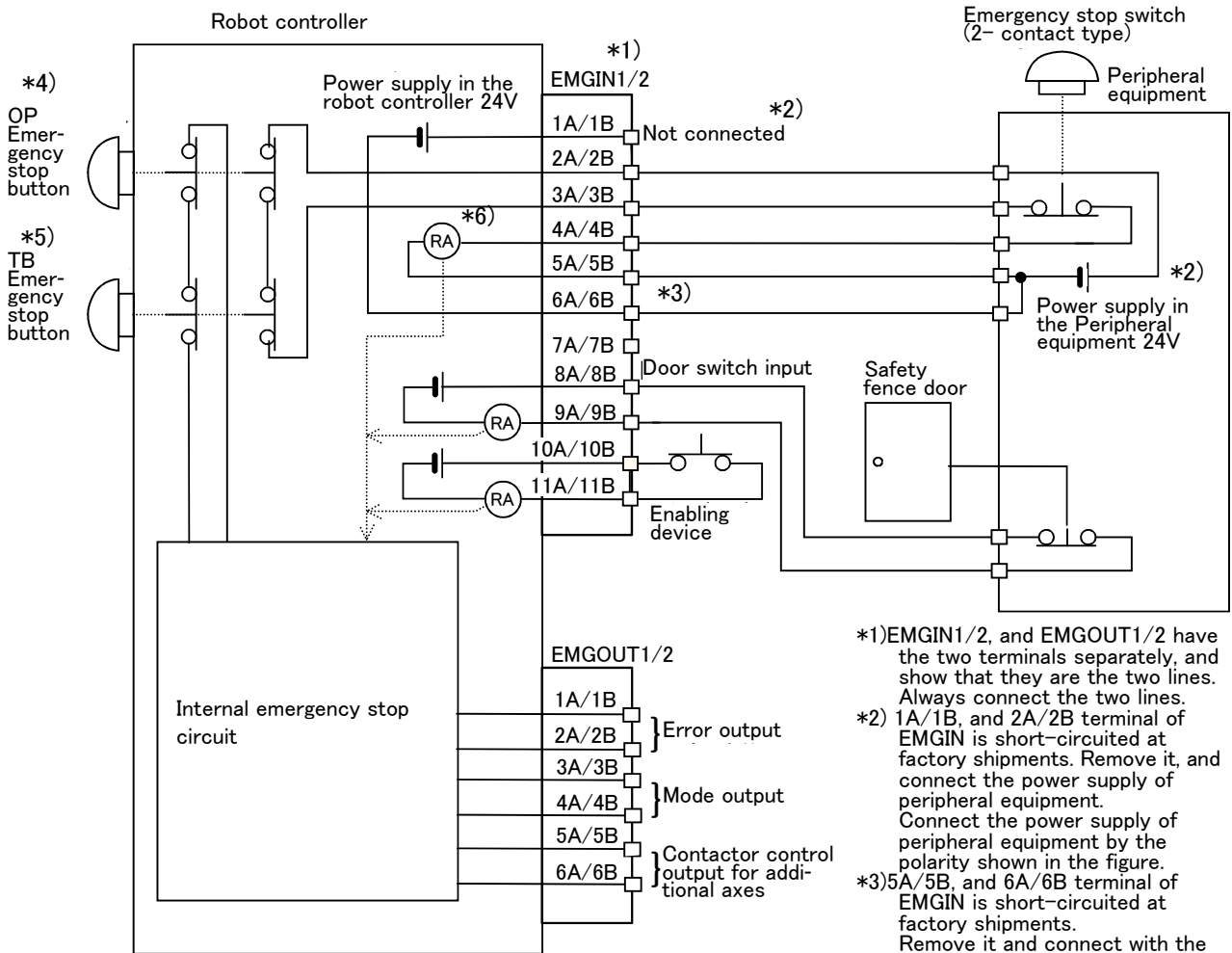

Fig.6-1 : Example of safety measures (Wiring example 1)

<Wiring example 2>: Connect the emergency stop switch of peripheral equipment to the robot controller.
 The power supply for emergency stop input uses the power supply of peripheral equipment.
 <Operation of the emergency stop>
 If the emergency stop switch of peripheral equipment is pushed, the robot will also be in the emergency stop state.



- *1)EMGIN1/2, and EMGO1/2 have the two terminals separately, and show that they are the two lines. Always connect the two lines.
- *2) 1A/1B, and 2A/2B terminal of EMGIN is short-circuited at factory shipments. Remove it, and connect the power supply of peripheral equipment by the polarity shown in the figure.
- *3)5A/5B, and 6A/6B terminal of EMGIN is short-circuited at factory shipments. Remove it and connect with the power supply ground of peripheral equipment.
- *4) The emergency stop button of the robot controller operation panel.
- *5) The emergency stop button of T/B connected to the robot controller.
- *6) Emergency stop input relay.

[Caution] Since we have omitted the information in part because of explanation, there is the section different from the product. Also refer to Page 66, "Fig.3-22 : External emergency stop connection".

Fig.6-2 : Example of safety measures (Wiring example 2)

<Wiring example 3>: Connect the emergency stop switch, door switch, and enabling device of peripheral equipment to the robot controller. The power supply for emergency stop input uses the power supply of peripheral equipment. Monitor the emergency stop state by the peripheral equipment side.

<Operation of the emergency stop>

If the emergency stop switch of peripheral equipment is pushed, the robot will also be in the emergency stop state. And, if the emergency stop switch of OP or T/B is pushed in the state of the power of robot controller OFF, peripheral equipment state can be the emergency stop also.

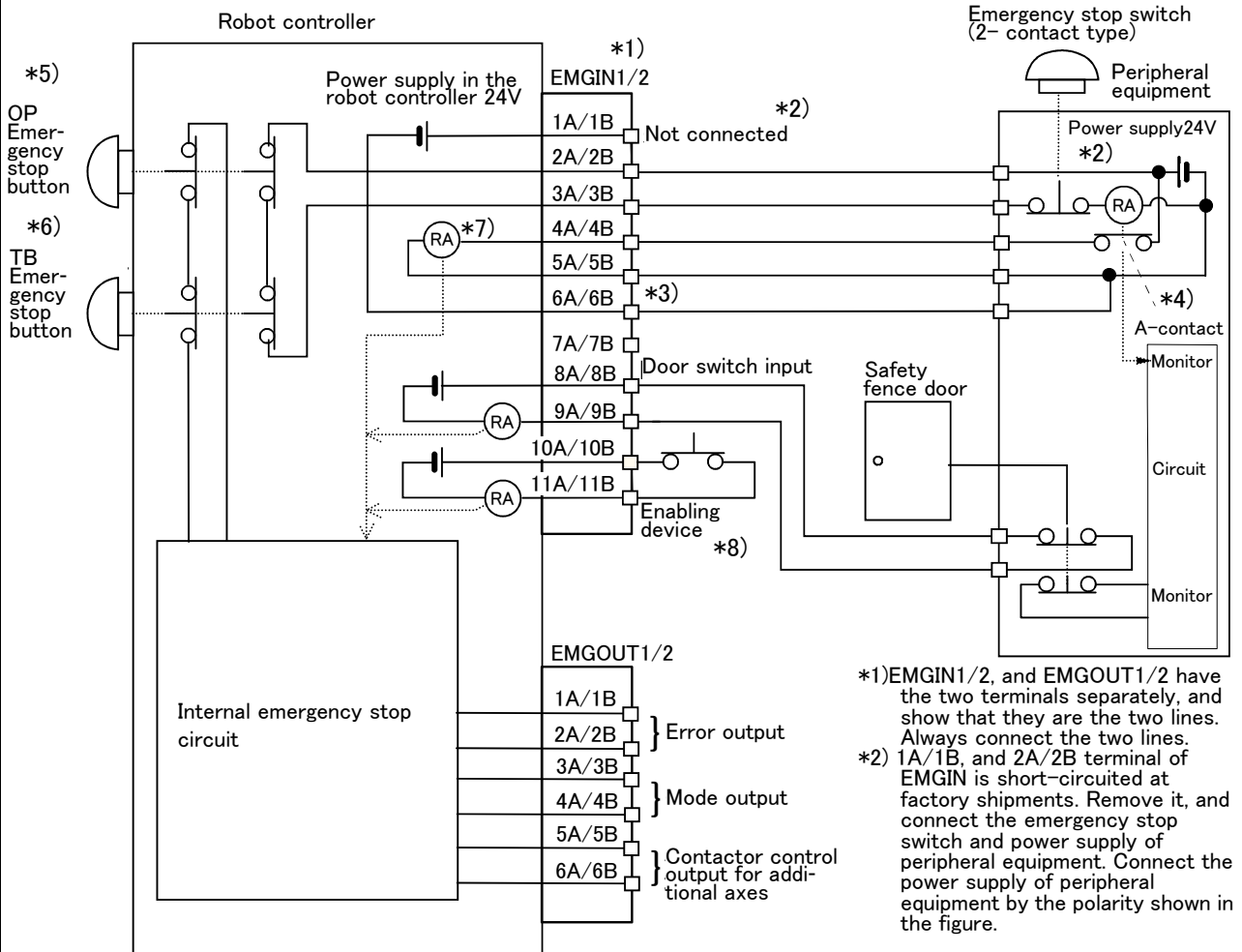

- *1) EMGIN1/2, and EMGOUT1/2 have the two terminals separately, and show that they are the two lines. Always connect the two lines.
- *2) 1A/1B, and 2A/2B terminal of EMGIN is short-circuited at factory shipments. Remove it, and connect the emergency stop switch and power supply of peripheral equipment. Connect the power supply of peripheral equipment by the polarity shown in the figure.

- *3) 5A/5B, and 6A/6B terminal of EMGIN is short-circuited at factory shipments. Remove it and connect with the power supply ground of peripheral equipment.
- *4) Please use a A contact type of the relay with the compulsive guide.
- *5) The emergency stop button of the robot controller operation panel.
- *6) The emergency stop button of T/B connected to the robot controller.
- *7) Emergency stop input relay.
- *8) Refer to Page 69, "3.6.4 Enabling device function" for the enabling device.

[Caution] Since we have omitted the information in part because of explanation, there is the section different from the product. Also refer to Page 66, "Fig.3-22 : External emergency stop connection".

Fig.6-3 : Example of safety measures (Wiring example 3)

<Wiring example 4>: Connect the emergency stop switch of peripheral equipment, and the door switch to two robot controllers, and it interlocks. Connect the enabling device to the robot controller. The power supply for emergency stop input uses the power supply of peripheral equipment. Monitor the emergency stop state by the peripheral equipment side.

<Operation of the emergency stop>

If the emergency stop switch of peripheral equipment is pushed, the robot will also be in the emergency stop state. And, if the emergency stop switch of OP or T/B is pushed in the state of the power of robot controller OFF, peripheral equipment state can be the emergency stop also.

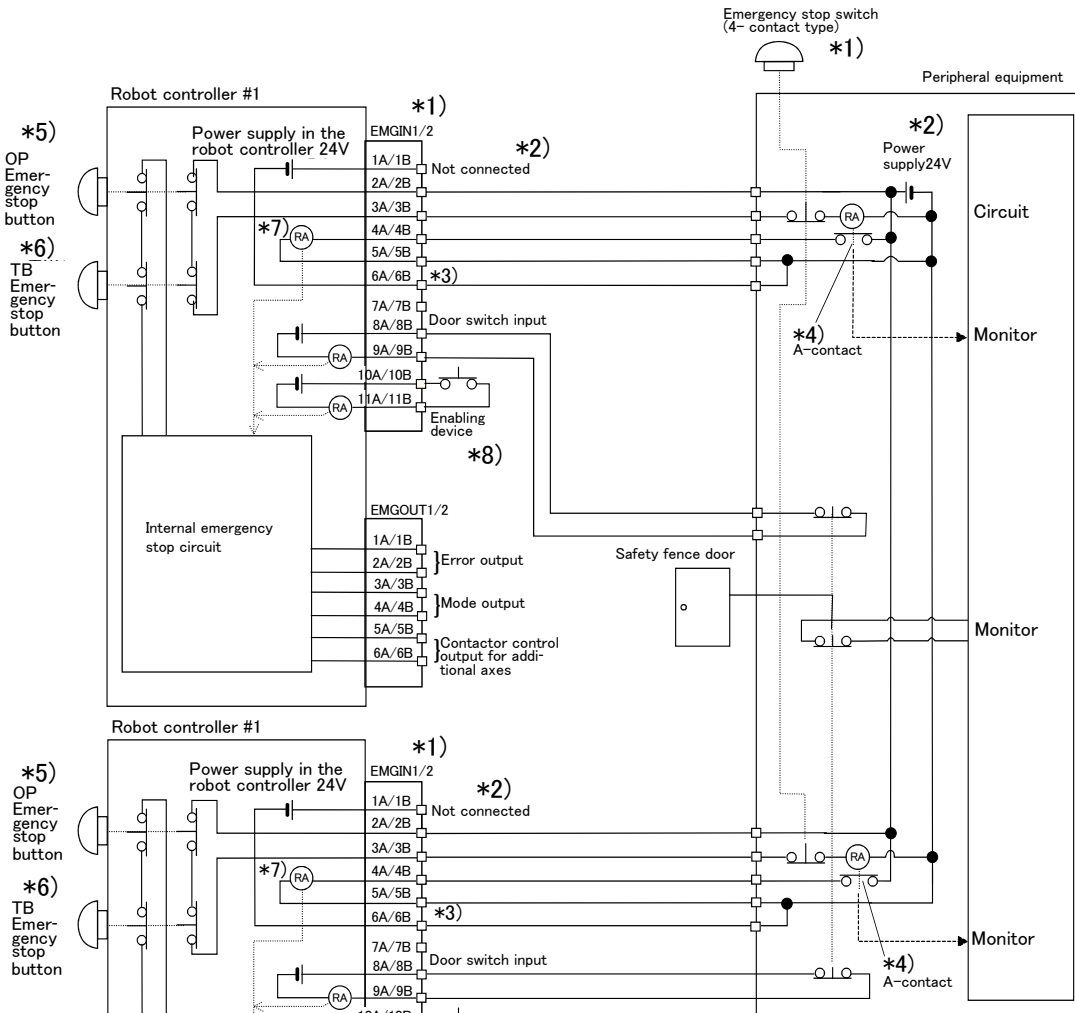

- *1) EMGIN1/2, and EMGOUT1/2 have the two terminals separately, and show that they are the two lines. Always connect the two lines.
If necessary to stop two robots simultaneously by one emergency stop switch please use the 4 contact type emergency stop switch.
- *2) 1A/1B, and 2A/2B terminal of EMGIN is short-circuited at factory shipments. Remove it, and connect the emergency stop switch and power supply of peripheral equipment. Connect the power supply of peripheral equipment by the polarity shown in the figure.
- *3) 5A/5B, and 6A/6B terminal of EMGIN is short-circuited at factory shipments. Remove it and connect with the power supply ground of peripheral equipment.
- Notes) Please use 5A/5B and 6A/6B terminal, connected.
- *4) Please use a A contact type of the relay with the compulsive guide.

- *5) The emergency stop button of the robot controller operation panel.
- *6) The emergency stop button of T/B connected to the robot controller.
- *7) Emergency stop input relay.
- *8) Refer to Page 69, "3.6.4 Enabling device function" for the enabling device.

[Caution] Since we have omitted the information in part because of explanation, there is the section different from the product. Also refer to Page 66, "Fig.3-22 : External emergency stop connection".

Fig.6-4 : Example of safety measures (Wiring example 4)

(1) External emergency stop connection [supplementary explanation]

- (1) Use a 2-contact type switch for all switches.
- (2) Install a limit switch on the safety fence's door. With a constantly open contact (a contact), wire to the door switch input terminal so that the switch turns ON (is conducted) when the door is closed, and turns OFF (is opened) when the door is open.
- (3) Use a manual-return type 2b-contact for the emergency stop button.
- (4) Classify the faults into minor faults (faults that are easily restored and that do not have a great effect) and major faults (faults that cause the entire system to stop immediately, and that require care in restoration), and wire accordingly.

[Caution] The emergency stop input (terminal block) on the user wiring in the controller can be used for safety measures as shown in Fig. 6-1 to Fig. 6-4. Note that there are limits to the No. of switch contacts, capacity and cable length, so refer to the following and install.

- Switch contact.....Prepare a 2-contact type.*1)
- Switch contact capacity.....Use a contact that operates with a switch contact capacity of approx. 1mA to 100mA/24V. *1)
If you connect the relay etc., rated current of the coil should use the relay which is 100mA/24V or less. (Refer to Fig. 6-5)
- Cable length.....The length of the wire between the switch and terminal block must be max. 15m or less. Please use the shield line, in case of the cable may receive the noise etc. by other equipment, such as servo amplifier. And, since the ferrite core is attached as noise measures parts, please utilize.

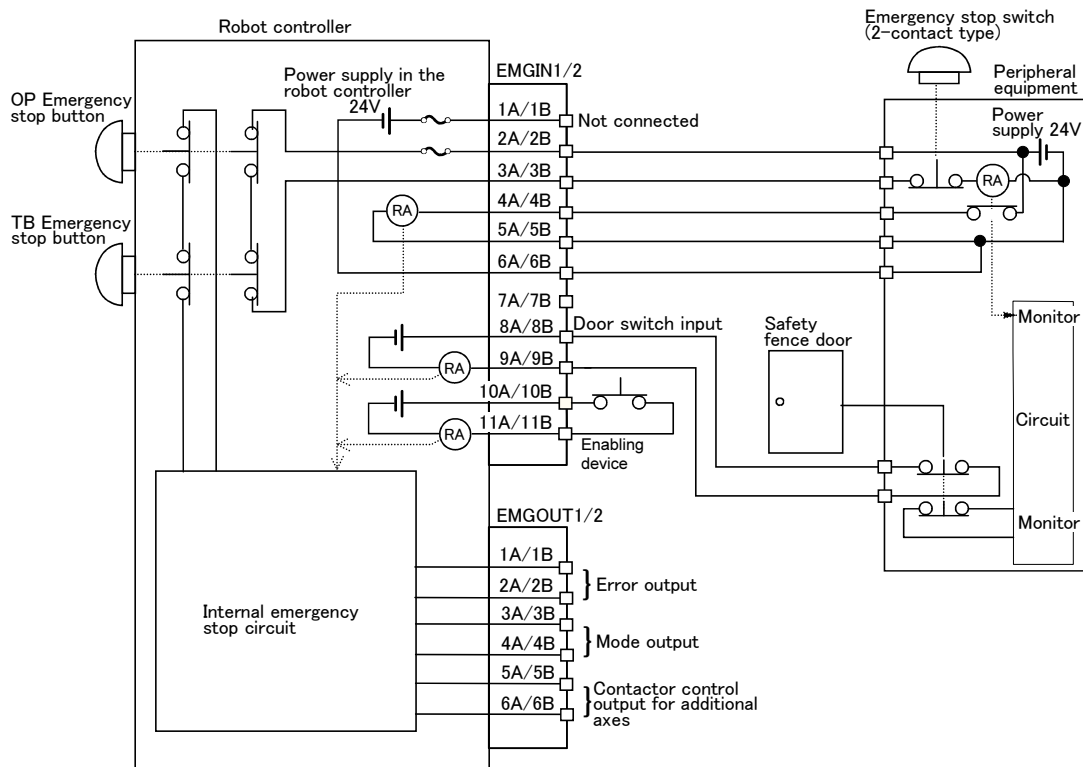

Fig.6-5 : Limitations when connecting the relay etc.

CAUTION You should always connect doubly connection of the emergency stop, the door switch, and the enabling switch. (Connect with both of side-A and side-B of the controller rear connector) In connection of only one side, if the relay of customer use should break down, it may not function correctly.

CAUTION Be sufficiently careful and wiring so that two or more emergency stop switches work independently. Don't function only on AND conditions (Two or more emergency stop switch status are all ON).

*1) The minimum load electric current of the switch is more than 5mA/24V.

6.2 Working environment

Avoid installation in the following places as the equipment's life and operation will be affected by the ambient environment conditions. When using in the following conditions, the customer must pay special attention to the preventive measures.

(1) Power supply

- Where the voltage fluctuation will exceed the input voltage range.
- Where a momentary power failure exceeding 20ms may occur.
- Where the power capacity cannot be sufficiently secured.

CAUTION

Please use the controller with an input power supply voltage fluctuation rate of 10% or less. In the case of 200 VAC input, for example, if the controller is used with 180 VAC during the day and 220 VAC during the night, turn the servo off once and then on again. If this is not performed, an excessive regeneration error may occur.

(2) Noise

- Where a surge voltage exceeding 1000V, 1 μ s may be applied on the primary voltage. Near large inverters, high output frequency oscillator, large contactors and welding machines. Static noise may enter the lines when this product is used near radios or televisions. Keep the robot away from these items.

(3) Temperature and humidity

- Where the atmospheric temperature exceeds 40 degree , lower than 0 degree.
- Where the relative humidity exceeds 85%, lower than 45%, and where dew may condense.
- Where the robot will be subject to direct sunlight or near heat generating sources such as heaters.

(4) Vibration

- Where excessive vibration or impact may be applied. (Use in an environment of 34m/s² or less during transportation and 5m/s² or less during operation.)

(5) Installation environment

- Where strong electric fields or magnetic fields are generated.
- Where the installation surface is rough. (Avoid installing the robot on a bumpy or inclined floor.)
- Where there is heavy powder dust and oil mist present.

6.3 Precautions for handling

- (1) This robot has brakes on all axes. The precision of the robot may drop, looseness may occur and the reduction gears may be damaged if the robot is moved with force with the brakes applied.
- (2) Avoid moving the robot arm by hand. When unavoidable, gradually move the arm. If moved suddenly, the accuracy may drop due to an excessive backlash, or the backed up data may be destroyed.
- (3) Note that depending on the posture, even when within the movement range, the wrist section could interfere with the base section. Take care to prevent interference during jog. ^{*1)}
- (4) The robot arm is configured of precision parts such as bearings. Grease is used for lubricating these parts. When cold starting at low temperatures or starting operation after long-term stoppage, the position accuracy may drop or servo alarms may occur. If these problems occur, perform a 5 to 10 minute running-in operation at a low speed (about a half of normal operating speed).
- (5) The robot arm and controller must be grounded with Class D grounding to secure the noise resistance and to prevent electric shocks.
- (6) The items described in these specifications are conditions for carrying out the periodic maintenance and inspections described in the instruction manual.
- (7) When using the robot arm on a mobile axis or elevating table, the machine cables enclosed as standard configuration may break due to the fixed installation specifications. In this case, use the machine cable extension (for flexed)" factory shipment special specifications or options.
- (8) If this robot interferes with the workpiece or peripheral devices during operation, the position may deviate, etc. Take care to prevent interference with the workpiece or peripheral devices during operation.
- (9) The hanging installation jig can be borrowed from the maker. Order to dealer when need.

*1) Jog operation refers to operating the robot manually using the teaching pendant.

-
- (10) Do not attach a tape or a label to the robot arm and the controller. If a tape or a label with strong adhesive power, such as a packaging tape, is attached to the coated surfaces of the robot arm and controller, the coated surface may be damaged when such tape or label is peeled off.
 - (11) If the robot is operated with a heavy load and at a high speed, the surface of the robot arm gets very hot. It would not result in burns, however, it may cause secondary accidents if touched carelessly.
 - (12) Do not shut down the input power supply to stop the robot. If the power supply is frequently shut down during a heavy load or high-speed operation, the speed reducer may be damaged, backlash may occur, and the program data may be destroyed.
 - (13) If the J1, J2 and J3 axes collide with the mechanical stopper during the automatic operation of the robot, it is necessary to replace the resin part of the mechanical stopper unit. For the replacement of the resin parts, please contact Mitsubishi or Mitsubishi's dealer.
If the resin part is not replaced, the mechanism unit and the speed reducer may be damaged significantly when the axes collide with the mechanical stopper next or subsequent time.
 - (14) During the robot's automatic operation, a break is applied to the robot arm when the input power supply is shut down by a power failure, for instance. When a break is applied, the arm may deviate from the operation path predetermined by automatic operation and, as a result, it may interfere with the mechanical stopper depending on the operation at shutdown. In such a case, take an appropriate measure in advance to prevent any dangerous situation from occurring due to the interference between the arm and peripheral devices.
Example) Installing a UPS (uninterruptible power supply unit) to the primary power source in order to reduce interference.
 - (15) Do not conduct an insulated voltage test. If conducted by mistake, it may result in a breakdown.
 - (16) Fretting may occur on the axis which moving angle or moving distance move minutely, or not moves. Fretting is that the required oil film becomes hard to be formed if the moving angle is small, and wear occurs. The axis which not moved is moving slightly by vibration etc. To make no fretting recommends to move these axes about once every day the 30 degree or more, or the 30mm or more.
 - (17) The United Nations' Recommendations on the Transport of Dangerous Goods must be observed for trans-border transportation of lithium batteries by air, sea, and land. The lithium batteries (Q6BAT,A6BAT) used in Mitsubishi industrial robots contain less than 1 g of lithium and are not classified as dangerous goods. However, if the quantity of lithium batteries exceeds 24 batteries for storage, etc., they will be classified as Class 9: Miscellaneous dangerous substances and articles. Shipping less than 24 batteries is recommended to avoid having to carry out transport safety measures as the customer's consignor. Note that some transportation companies may request an indication that the batteries are not dangerous goods be included on the invoice. For shipping requirement details, please contact your transportation company.
 - (18) If the air supply temperature (primary piping) used for the tool etc. is lower than ambient air temperature, the dew condensation may occur on the coupling or the hose surface.

7 Appendix

Appendix 1 : Specifications discussion material

■ Customer information

Company name		Name	
Address		Telephone	

■ Purchased mode

Specification	Type ^{Note1)}
Standard specification	<input type="checkbox"/> RV-6SQ <input type="checkbox"/> RV-6SQL <input type="checkbox"/> RV-6SQ-SM <input type="checkbox"/> RV-6SQL-SM
Clean specification	<input type="checkbox"/> RV-6SQC <input type="checkbox"/> RV-6SQLC
CE Marking specification ^{Note2)}	<input type="checkbox"/> Not provided <input type="checkbox"/> "-S12" specification(CR2QA-700-S12) <input type="checkbox"/> "-SM612" specification(CR3Q-700M-SM612)

Note1) Refer to the Page 2, "1.2 Model type name of robot" for the details of the robot arm type name.

Note2) The brake is attached to all axes for CE marking specification.

■ Shipping special specifications (Settings can be made only at time of shipment)

Item	Standard specifications	Special shipping specifications
Controller	Structure <input type="checkbox"/> CR2QA-711 Floor type	<input type="checkbox"/> CR3Q-711M (IP54) <input type="checkbox"/> Floor type <input type="checkbox"/> Caster type

■ Options (Installable after shipment)

Item	Type	Provision, and specifications when provided.
Robot arm	Operating range change	1S-DH-02 <input type="checkbox"/> Not provided <input type="checkbox"/> Provided
	Machine cable extention	1S- <input type="checkbox"/> <input type="checkbox"/> CBL-01 <input type="checkbox"/> Not provided <input type="checkbox"/> 5m fixing <input type="checkbox"/> 10m fixing <input type="checkbox"/> 15m fixing
		1S- <input type="checkbox"/> <input type="checkbox"/> LCBL-01 <input type="checkbox"/> Not provided <input type="checkbox"/> 5m bending <input type="checkbox"/> 10m bending <input type="checkbox"/> 15m bending
	Solenoid valve set	1S-VD0 <input type="checkbox"/> -02 <input type="checkbox"/> Not provided Sink <input type="checkbox"/> 1 set <input type="checkbox"/> 2 sets <input type="checkbox"/> 3 sets <input type="checkbox"/> 4 stes Source <input type="checkbox"/> 1 set <input type="checkbox"/> 2 sets <input type="checkbox"/> 3 sets <input type="checkbox"/> 4 stes
	Hand input cable	1S-HC25C-01 <input type="checkbox"/> Not provided <input type="checkbox"/> Provided
	Hand output cable	1S-GR35S-01 <input type="checkbox"/> Not provided <input type="checkbox"/> Provided
Hand curl tube	1E-ST040 <input type="checkbox"/> C <input type="checkbox"/> Not provided <input type="checkbox"/> 1 set <input type="checkbox"/> 2 sets <input type="checkbox"/> 3 sets <input type="checkbox"/> 4 stes	
Controller	Teaching pendant	R32TB- <input type="checkbox"/> <input type="checkbox"/> <input type="checkbox"/> Not provided <input type="checkbox"/> 7m <input type="checkbox"/> 15m
		R56TB- <input type="checkbox"/> <input type="checkbox"/> <input type="checkbox"/> Not provided <input type="checkbox"/> 7m <input type="checkbox"/> 15m
	Pneumatic hand interface	2A-RZ365/2A-RZ375 <input type="checkbox"/> Not provided <input type="checkbox"/> 2A-RZ365(Sink) <input type="checkbox"/> 2A-RZ375(Source)
	The set of cable between drive unit and robot CPU ^{Note1)}	2Q-RC-CBL <input type="checkbox"/> <input type="checkbox"/> M <input type="checkbox"/> Not provided <input type="checkbox"/> 5m <input type="checkbox"/> 10m <input type="checkbox"/> 20m <input type="checkbox"/> 30m
	RT ToolBox2	3D-11C-WINE <input type="checkbox"/> Not provided <input type="checkbox"/> Windows2000/XP/Vista English CD-ROM
	RT ToolBox2 mini	3D-12C-WINE <input type="checkbox"/> Not provided <input type="checkbox"/> Windows2000/XP/Vista English CD-ROM
Instructions manual	5S-QB00-PE01 <input type="checkbox"/> Not provided <input type="checkbox"/> Provided () set	

Note1) The four type cables shown in below are contained.

- 1)2Q-TUCBL M, 2)2Q-DISPCBL M, 3)2QEMICBL M,
- 4)MR-J3BUS M-A (5m, 20m) or MR-J3BUS M-A (30m)

■ Maintenance parts (Consumable parts)

Maintenance parts	<input type="checkbox"/> Backup batteries A6BAT () pcs. <input type="checkbox"/> Backup batteries Q6BAT () pcs. <input type="checkbox"/> Grease () cans
-------------------	--

■ Robot selection check list

Work description	<input type="checkbox"/> Material handling <input type="checkbox"/> Assembly <input type="checkbox"/> Machining L/UL <input type="checkbox"/> Sealing <input type="checkbox"/> Testing and inspection <input type="checkbox"/> Other ()		
Workpiece mass ()g	Hand mass ()g	Atmosphere <input type="checkbox"/> General environment <input type="checkbox"/> Clean <input type="checkbox"/> Dust provided <input type="checkbox"/> Other()	
Remarks			

Copy this page and use the copy.



Product Service

EC-Statement of Compliance

No. E6 12 03 25554 042

Holder of Certificate: Mitsubishi Electric CorporationTokyo BILD., 2-7-3 Marunouchi,
Chiyoda-ku
Tokyo
100-8310 JAPAN**Name of Object:** Industrial, Scientific and Medical
equipment
Industrial Robot**Model(s):** SQ series
(See Attachment for Nomenclature)**Description of
Object:**

Rated Voltage:	230 VAC (1 phase)/ 230 VAC, 400 VAC (3 phase)
Rated Power:	0.6 kW (230 VAC)/ 1.7 kW (230 VAC)/ 3.4 kW (230 VAC, 400 VAC)
Protection Class:	I

**Tested
according to:** EN 61000-6-4:2007
EN 61000-6-2:2005

This EC-Statement of Compliance is issued according to the Directive 2004/108/EC relating to electromagnetic compatibility. It confirms that the listed apparatus complies with such aspects of the essential requirements of the EMC directive as specified by the manufacturer or his authorized representative in the European Community and applies only to the sample and its technical documentation submitted to TÜV SÜD Product Service GmbH for testing and certification. See also notes overleaf.

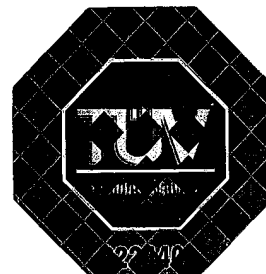
Technical report no.: 73536415**Date,** 2012-03-05 (Johann Roidt)

TÜV SÜD Product Service GmbH is Notified Body to the Directive 2004/108/EC of the European Parliament and of the council with the identification number 0123.

Page 1 of 10



E6 12 03 25554 042

SQ series Grouping Items

1. AC 400V /230V 3 phase 3.4kW

- | | |
|--------------------------|----------------------------|
| 1. RV-12SQ(-S**) | 33. RH-12SQH7030M-SULM6** |
| 2. RV-12SQL(-S**) | 34. RH-12SQH5530M-SULM6** |
| 3. RV-12SQC(-S**) | 35. RH-12SQH8530M-SULM6** |
| 4. RV-12SQLC(-S**) | 36. RH-18SQH8530M-SULM6** |
| 5. RV-12SQ-SUL** | 37. RH-6SQH4527M-SM6** |
| 6. RV-12SQL-SUL** | 38. RH-6SQH3527M-SM6** |
| 7. RV-12SQC-SUL** | 39. RH-6SQH5527M-SM6** |
| 8. RV-12SQLC-SUL** | 40. RH-6SQH4527M-SULM6** |
| 9. RV-18SQ(-S**) | 41. RH-6SQH3527M-SULM6** |
| 10. RV-18SQC(-S**) | 42. RH-6SQH5527M-SULM6** |
| 11. RV-18SQ-SUL** | 43. RH-12SQH7038M-SM6** |
| 12. RV-18SQC-SUL** | 44. RH-12SQH5538M-SM6** |
| 13. RV-6SQ-SM6** | 45. RH-12SQH8538M-SM6** |
| 14. RV-6SQL-SM6** | 46. RH-12SQH7038M-SULM6** |
| 15. RV-6SQ-SULM6** | 47. RH-12SQH5538M-SULM6** |
| 16. RV-6SQL-SULM6** | 48. RH-12SQH8538M-SULM6** |
| 17. RV-3SQ-SM6** | 49. RH-20SQH8538M-SM6** |
| 18. RV-3SQB-SM6** | 50. RH-20SQH8530M-SM6** |
| 19. RV-3SQB-SULM6** | 51. RH-20SQH10038M-SM6** |
| 20. RV-3SQJ-SM6** | 52. RH-20SQH10030M-SM6** |
| 21. RV-3SQJB-SM6** | 53. RH-20SQH8538M-SULM6** |
| 22. RV-3SQJB-SULM6** | 54. RH-20SQH8530M-SULM6** |
| 23. RH-6SQH4517M-SM6** | 55. RH-20SQH10038M-SULM6** |
| 24. RH-6SQH3517M-SM6** | 56. RH-20SQH10030M-SULM6** |
| 25. RH-6SQH5517M-SM6** | 57. RH-3SQHR3512MW-SM6** |
| 26. RH-6SQH4517M-SULM6** | 58. RH-3SQHR5512MW-SM6** |
| 27. RH-6SQH3517M-SULM6** | 59. RH-3SQHR3512MW-SULM6** |
| 28. RH-6SQH5517M-SULM6** | 60. RH-3SQHR5512MW-SULM6** |
| 29. RH-12SQH7030M-SM6** | 61. RH-3SQHR3512M-SM6** |
| 30. RH-12SQH5530M-SM6** | 62. RH-3SQHR5512M-SM6** |
| 31. RH-12SQH8530M-SM6** | 63. RH-3SQHR3512M-SULM6** |
| 32. RH-18SQH8530M-SM6** | 64. RH-3SQHR5512M-SULM6** |

Attachment
Statement No.



Product Service

E6 12 03 25554 042

65. RH-3SQHR3512W-SM6**
66. RH-3SQHR5512W-SM6**
67. RH-3SQHR3512W-SULM6**
68. RH-3SQHR5512W-SULM6**

2. AC 230V 1 phase 1.7kW

- | | |
|-----------------------|-------------------------|
| 1. RV-6SQ(-S**) | 30. RH-6SQH4520-SUL3** |
| 2. RV-6SQL(-S**) | 31. RH-6SQH3520-SUL3** |
| 3. RV-6SQC(-S**) | 32. RH-6SQH5520-SUL3** |
| 4. RV-6SQLC(-S**) | 33. RH-6SQH4517M-SUL3** |
| 5. RV-6SQ-SUL** | 34. RH-6SQH3517M-SUL3** |
| 6. RV-6SQL-SUL** | 35. RH-6SQH5517M-SUL3** |
| 7. RV-6SQC-SUL** | 36. RH-6SQH4517C-SUL3** |
| 8. RV-6SQLC-SUL** | 37. RH-6SQH3517C-SUL3** |
| 9. RV-3SQ-S3** | 38. RH-6SQH5517C-SUL3** |
| 10. RV-3SQC-S3** | 39. RH-12SQH7035(-S**) |
| 11. RV-3SQB-S3** | 40. RH-12SQH5535(-S**) |
| 12. RV-3SQBC-S3** | 41. RH-12SQH8535(-S**) |
| 13. RV-3SQB-SUL3** | 42. RH-18SQH8535(-S**) |
| 14. RV-3SQBC-SUL3** | 43. RH-12SQH7030M(-S**) |
| 15. RV-3SQJ-S3** | 44. RH-12SQH5530M(-S**) |
| 16. RV-3SQJC-S3** | 45. RH-12SQH8530M(-S**) |
| 17. RV-3SQJB-S3** | 46. RH-18SQH8530M(-S**) |
| 18. RV-3SQJBC-S3** | 47. RH-12SQH7030C(-S**) |
| 19. RV-3SQJB-SUL3** | 48. RH-12SQH5530C(-S**) |
| 20. RV-3SQJBC-SUL3** | 49. RH-12SQH8530C(-S**) |
| 21. RH-6SQH4520-S3** | 50. RH-18SQH8530C(-S**) |
| 22. RH-6SQH3520-S3** | 51. RH-12SQH7035-SUL** |
| 23. RH-6SQH5520-S3** | 52. RH-12SQH5535-SUL** |
| 24. RH-6SQH4517M-S3** | 53. RH-12SQH8535-SUL** |
| 25. RH-6SQH3517M-S3** | 54. RH-18SQH8535-SUL** |
| 26. RH-6SQH5517M-S3** | 55. RH-12SQH7030M-SUL** |
| 27. RH-6SQH4517C-S3** | 56. RH-12SQH5530M-SUL** |
| 28. RH-6SQH3517C-S3** | 57. RH-12SQH8530M-SUL** |
| 29. RH-6SQH5517C-S3** | 58. RH-18SQH8530M-SUL** |

Page 3 of 10



E6 12 03 25554 042

- | | |
|--------------------------|--------------------------|
| 59. RH-12SQH7030C-SUL** | 94. RH-12SQH8538C-SUL** |
| 60. RH-12SQH5530C-SUL** | 95. RH-20SQH8545 (-S**) |
| 61. RH-12SQH8530C-SUL** | 96. RH-20SQH8535(-S**) |
| 62. RH-18SQH8530C-SUL** | 97. RH-20SQH10045(-S**) |
| 63. RV-12SQ-S3** | 98. RH-20SQH10035(-S**) |
| 64. RV-12SQL-S3** | 99. RH-6SQH4532-S3** |
| 65. RV-12SQC-S3** | 100. RH-6SQH3532-S3** |
| 66. RV-12SQLC-S3** | 101. RH-6SQH5532-S3** |
| 67. RV-12SQ-SUL3** | 102. RH-6SQH4527M-S3** |
| 68. RV-12SQL-SUL3** | 103. RH-6SQH3527M-S3** |
| 69. RV-12SQC-SUL3** | 104. RH-6SQH5527M-S3** |
| 70. RV-12SQLC-SUL3** | 105. RH-6SQH4527C-S3** |
| 71. RH-20SQH8538M(-S**) | 106. RH-6SQH3527C-S3** |
| 72. RH-20SQH8530M(-S**) | 107. RH-6SQH5527C-S3** |
| 73. RH-20SQH10038M(-S**) | 108. RH-6SQH4532-SUL3** |
| 74. RH-20SQH10030M(-S**) | 109. RH-6SQH3532-SUL3** |
| 75. RH-20SQH8538C(-S**) | 110. RH-6SQH5532-SUL3** |
| 76. RH-20SQH8530C(-S**) | 111. RH-6SQH4527M-SUL3** |
| 77. RH-20SQH10038C(-S**) | 112. RH-6SQH3527M-SUL3** |
| 78. RH-20SQH10030C(-S**) | 113. RH-6SQH5527M-SUL3** |
| 79. RH-20SQH8545 -SUL** | 114. RH-6SQH4527C-SUL3** |
| 80. RH-20SQH8535-SUL** | 115. RH-6SQH3527C-SUL3** |
| 81. RH-20SQH10045-SUL** | 116. RH-6SQH5527C-SUL3** |
| 82. RH-20SQH10035-SUL** | 117. RH-12SQH7045(-S**) |
| 83. RH-20SQH8538M-SUL** | 118. RH-12SQH5545(-S**) |
| 84. RH-20SQH8530M-SUL** | 119. RH-12SQH8545(-S**) |
| 85. RH-20SQH10038M-SUL** | 120. RH-12SQH7038M(-S**) |
| 86. RH-20SQH10030M-SUL** | 121. RH-12SQH5538M(-S**) |
| 87. RH-20SQH8538C-SUL** | 122. RH-12SQH8538M(-S**) |
| 88. RH-20SQH8530C-SUL** | 123. RH-12SQH7038C(-S**) |
| 89. RH-20SQH10038C-SUL** | 124. RH-12SQH5538C(-S**) |
| 90. RH-20SQH10030C-SUL** | 125. RH-12SQH8538C(-S**) |
| 91. RH-12SQH8538M-SUL** | 126. RH-12SQH7045-SUL** |
| 92. RH-12SQH7038C-SUL** | 127. RH-12SQH5545-SUL** |
| 93. RH-12SQH5538C-SUL** | 128. RH-12SQH8545-SUL** |

Attachment
Statement No.



Product Service

E6 12 03 25554 042

- | | | | |
|------|----------------------|------|----------------------|
| 129. | RH-12SQH7038M-SUL** | 142. | RH-3SQHR5512MW(-S**) |
| 130. | RH-12SQH5538M-SUL** | 143. | RH-3SQHR3515W-SUL** |
| 131. | RH-3SQHR3515W(-S**) | 144. | RH-3SQHR5515W-SUL** |
| 132. | RH-3SQHR5515W(-S**) | 145. | RH-3SQHR3512MW-SUL** |
| 133. | RH-3SQHR3512MW(-S**) | 146. | RH-3SQHR5512MW-SUL** |
| 134. | RH-3SQHR5512MW(-S**) | 147. | RH-3SQHR3512W (-S**) |
| 135. | RH-3SQHR3515W-SUL** | 148. | RH-3SQHR5512W (-S**) |
| 136. | RH-3SQHR5515W-SUL** | 149. | RH-3SQHR3512C (-S**) |
| 137. | RH-3SQHR3512MW-SUL** | 150. | RH-3SQHR5512C(-S**) |
| 138. | RH-3SQHR5512MW-SUL** | 151. | RH-3SQHR3512W-SUL** |
| 139. | RH-3SQHR3515W(-S**) | 152. | RH-3SQHR5512W-SUL** |
| 140. | RH-3SQHR5515W(-S**) | 153. | RH-3SQHR3512C-SUL** |
| 141. | RH-3SQHR3512MW(-S**) | 154. | RH-3SQHR5512C-SUL |

3. AC 230V 1 phase 0.6kW

- | | | | |
|-----|------------------|-----|---------------------|
| 1. | RV-2SQ(-S**) | 17. | RH-6SQH3517M-S** |
| 2. | RV-2SQB(-S**) | 18. | RH-6SQH5517M-S** |
| 3. | RV-2SQ-S12 | 19. | RH-6SQH4517C-S** |
| 4. | RV-2SQB-S12 | 20. | RH-6SQH3517C-S** |
| 5. | RV-3SQ-S** | 21. | RH-6SQH5517C-S** |
| 6. | RV-3SQC-S** | 22. | RH-6SQH4532(-S**) |
| 7. | RV-3SQB-S** | 23. | RH-6SQH3532(-S**) |
| 8. | RV-3SQBC-S** | 24. | RH-6SQH5532(-S**) |
| 9. | RV-3SQJ-S** | 25. | RH-6SQH4527M(-S**) |
| 10. | RV-3SQJC-S** | 26. | RH-6SQH3527M(-S**) |
| 11. | RV-3SQJB-S** | 27. | RH-6SQH5527M(-S**) |
| 12. | RV-3SQJBC-S** | 28. | RH-6SQH4527C(-S**) |
| 13. | RH-6SQH4520-S** | 29. | RH-6SQH3527C(-S**) |
| 14. | RH-6SQH3520-S** | 30. | RH-6SQH5527C(-S**) |
| 15. | RH-6SQH5520-S** | 31. | RH-3SQHR3515N(-S**) |
| 16. | RH-6SQH4517M-S** | 32. | RH-3SQHR5515N(-S**) |

Attachment
Statement No.



Product Service

E6 12 03 25554 042

Nomenclature

Group A, B Model name description is shown as follows.

R V - x SQ x - x

(1) (2) (3) (4) (5)

(1) V: Vertical Robot

(2) Maximum Payload specification:

6 : 6kg

12 : 12kg

18 : 18kg

(3) **SQ** : **SQ** series robot

(4) **L** : Arm extension model

C : Clean room model

LC : Clean room arm

extension model

(5) Dimension and Ambient specification:

[none] : driven by R/C

CR3Q-7*1M (for RV-12SQ/18SQ)

CR2Q-7*1/ CR2QA-7*1 (for RV-6SQ)

SM6xx: Oil mist model driven by R/C

CR3Q-7*1M-SM6xx (only RV-6SQ)

SULxx:UL specification/driven by R/C

CR3Q-7*1M-SULxx (for RV-12SQ/18SQ)

CR2Q-7*1-SULxx (for RV-6SQ)

SULM6xx:UL specification/

Oil mist model driven by R/C

CR3Q-7*1M-SULM6xx(only RV-6SQ)

S3xx: driven by R/C CR2Q-7*1-S3xx/ CR2QA-7*1-S3xx(only RV-12SQ)

Attachment
Statement No.



Product Service

E6 12 03 25554 042

Group C Model name description is shown as follows.

RV-3 SQ J B x - x
(1) (2) (3) (4) (5) (6) (7)

(1) **V**: Vertical Robot

(2) Rated Payload specification:

3 : 3kg

(3) **SQ** : **SQ** series robot

(4) **J** : 5 axes exist

[none] : 6 axes exist

(5) **B** : All axes are equipped with brake

[none] : Basic model

J4 axis and J6 axis are not equipped with brake.

(6) **C** : Clean room model

[none] : Basic model

(7) Special specification number

Pilot number and specification as follows

Sxx : driven by R/C CR1QA-7*1-Sxx

S3xx : driven by R/C CR2Q-7*1-S3xx/ CR2QA-7*1-S3xx

SM6xx : R/C Oil mist model

driven by R/C CR3Q-7*1M-SM6xx

SUL3xx: UL specification and R/C Oil mist model

driven by R/C CR2Q-7*1-SUL3xx

SULM6xx: UL specification R/C Oil mist model

driven by R/C CR3Q-7*1M-SULM6xx

Attachment
Statement No.



Product Service

E6 12 03 25554 042

Group D Model name description is shown as follows.

RH-x SQH xx xx x - xx

(1) (2) (3) (4) (5) (6) (7)

(1)H: Horizontal Robot

(2) Maximum Payload specification:

6 : 6kg

12 : 12kg

18 : 18kg

20 : 20kg

(3) **SQ** : **SQ** series robot

(4) Arm length(No1 and No2 arm) specification:

35 : 350 mm arm **70** : 700 mm arm

45 : 450 mm arm **85** : 850 mm arm

55 : 550 mm arm **100** : 1000 mm arm

(5) Z axis working area specification:

17 : 170 mm arm **32** : 320 mm arm

20 : 200 mm arm **35** : 350 mm arm

27 : 270 mm arm **38** : 380 mm arm

30 : 300 mm arm **45** : 450 mm arm

(6) Dimension and Ambient specification:

M : Oil mist model

C : Clean room model

[none] : Basic model

Attachment
Statement No.



Product Service

E6 12 03 25554 042

(7) Optional specification:

Sxx : RH-6SQH driven by R/C CR1QA-7*1-Sxx
RH-12/18/20SQH driven by R/C CR2Q-7*1-Sxx/ CR2QA-7*1-Sxx

S3xx : driven by R/C CR2Q-7*1-S3xx/ CR2QA-7*1-S3xx
(only RH-6SQH)

SM6xx: Oil mist model driven by R/C
CR3Q-7*1-SM6xx

SULxx: UL specification driven by R/C
CR3Q-7*1M-SULxx
(only RH-12 / 18SQH)

SUL3xx: UL specification driven by R/C
CR2Q-7*1-SUL3xx (only RH-6SQH)

SULM6xx: UL specification /
Oil mist model driven by R/C
CR3Q-7*1M-SULM6xx
(only RV-12 / 18SQH)

Group E Model name description is shown as follows.

<u>RV-2</u>	<u>SQ</u>	<u>B</u>	-	<u>x</u>
(1) (2)	(3)	(4)		(5)

(1) V: Vertical Robot

(2) Rated Payload specification:

2 : 2kg

(3) **SQ** : **SQ** series robot

(4) **B** : All axes are equipped with brake

[none] : Basic model

J4 axis and J6 axis are not equipped with brake.

(5) Special specification number

Pilot number and specification as follows

Sxx : driven by R/C CR1QA-77*-Sxx

S12 : machine cable connectors (between Robot arm and Robot controller) are original square type.
driven by R/C CR1QA-77*-S12

Page 9 of 10



E6 12 03 25554 042

Group F Model name description is shown as follows.

RH-3 SQHR xx xx x x - xx

(1) (2) (3) (4) (5) (6) (7) (8) (9)

(1)H: Horizontal Robot

(2) Maximum Payload specification:

3 : 3kg

(3) **SQ** : **SQ** series robot

(4) **R** : Reverse mount model

(5) Arm length(No1 and No2 arm) specification:

35 : 350 mm arm

55 : 550 mm arm

(6) Z axis working area specification:

12 : 120 mm arm

15 : 150 mm arm

(7) Dimension and Ambient specification:

[none] : Basic model

M : Oil mist model

W : Water proof model

C : Clean room model

(8) Special specification:

W : Basic model

N : the special machine cable model driven by CR1QA-781-Sxx

[none] : Basic model ,regular type (same with "W")

(9) Optional specification:

Sxx : RH-3SQHRxxxxN driven by R/C, CR1DA-781-Sxx

RH-3SQHRxxxxW

and RH-3SQHRxxxx driven by R/C, CR2QA-781-Sxx

SM6xx: Oil mist model driven by R/C, CR3Q-781M-SM6xx

SULxx: UL specification driven by R/C, CR3Q-781M-SULxx

SULM6xx:UL specification /Oil mist model driven by R/C, CR3Q-781M-SULM6xx

EC Declaration of Conformity

We, the undersigned,

Manufacturer	MITSUBISHI ELECTRIC CORPORATION NAGOYA WORKS
Address, City	1-14,Yada-minami 5-chome, Higashi-ku, Nagoya 461-8670
Country	Japan
Phone number	+81 52 712 2354
Fax number/e-mail	+81 52 722 0384
Authorized representative in Europe	MITSUBISHI Electric Europe B.V
Address, City	40880 Ratingen
Country	Germany

Certify and declare under our sole responsibility that the following apparatus:

Type Name	Industrial Robot
Manufacturer	MITSUBISHI ELECTRIC CORPORATION NAGOYA WORKS
Brand	MELFA
Model No.	SQ series
Restrictive use	For industrial environment only

Conforms with the essential requirements of the **EMC Directive 2004/108/EC** and the **Machinery Directive 2006/42/EC**, based on the following specifications applied:

EU Harmonized Standards		Non-harmonized Standard
EMC(2004/108/EC)	EN61000-6-4:2007 EN61000-6-2:2005	N/A
Machinery(2006/42/EC)	Type A: Fundamental safety standards EN ISO12100-1:2003 EN ISO12100-2:2003 EN 1050:1997 Type B: Group safety standards B1: Safety aspects EN60204-1:2006, EN294:1992, EN349:1993 ISO13849-1:2006 Type C: Machine Safety standard ISO10218-1:2011	N/A

and therefore complies with the essential requirements and provisions of the EMC Directive and the Machinery

Directive.

The Technical documentation is kept at the following address:

Company	MITSUBISHI Electric Europe B.V
Address, City	Gothaer St. 8 40880 Ratingen
Country	Germany
Phone number	+49 2102 486 0
Fax number	+49 2102 486 1120

Date	February 20, 2012
Name and position of person binding the manufacturer	<p><i>Tomoyuki Kobayashi</i></p> <hr/> <p>Tomoyuki Kobayashi Senior Manager Robot Manufacturing Department MITSUBISHI ELECTRIC CORPORATION NAGOYA WORKS</p>

■ Declaration Type of models

Table 1 : The list of RV-12SQ series for grouping certification. ;A group

No.	Classification	Model name	Robot Controller
		12/18kg-Load	
1	Oil mist basic model	RV-12SQ(-S**)	CR3Q-701M(-S**)
2	Oil mist arm extension model	RV-12SQL(-S**)	
3	Clean room basic model (Class 10)	RV-12SQC(-S**)	CR3Q-701(-S**)
4	Clean room arm extension model (Class 10)	RV-12SQLC(-S**)	
5	Oil mist basic model , 1Phase Power model Robot controller	RV-12SQ-S3**	CR2Q-701-S3**/ CR2QA-701-S3**
6	Oil mist arm extension model, with 1Phase Power model Robot controller	RV-12SQL-S3**	
7	Clean room basic model (Class 10) 1Phase Power model Robot controller	RV-12SQC-S3**	
8	Clean room arm extension model (Class 10) with 1Phase Power model Robot controller	RV-12SQLC-S3**	
9	UL specification oil mist basic model with 1Phase Power model Robot controller	RV-12SQ-SUL3**	CR2Q-701-SUL3**
10	UL specification oil mist arm extension model with 1Phase Power model Robot controller	RV-12SQL-SUL3**	
11	UL specification oil mist basic model with 1Phase Power model Robot controller	RV-12SQC-SUL3**	
12	UL specification oil mist arm extension model with 1Phase Power model Robot controller	RV-12SQLC-SUL3**	
13	UL specification oil mist basic model including oil mist model robot controller	RV-12SQ-SUL**	CR3Q-701M-SUL**
14	UL specification oil mist arm extension model including oil mist model robot controller	RV-12SQL-SUL**	
15	UL specification clean room basic model (Class 10)	RV-12SQC-SUL**	CR3Q-701-SUL**
16	UL specification clean room arm extension model (Class 10)	RV-12SQLC-SUL**	
17	Oil mist basic model	RV-18SQ(-S**)	CR3Q-709M(-S**)
18	Clean room basic model (Class 10)	RV-18SQC(-S**)	
19	UL specification oil mist basic model including oil mist model robot controller	RV-18SQ-SUL**	CR3Q-709-SUL**
20	UL specification clean room basic model (Class 10)	RV-18SQC-SUL**	

Table 2 : The list of RV-6SQ series for grouping certification. B group

No.	Classification	Model name	Robot Controller
		6kg-Load	
1	Oil mist basic model	RV-6SQ(-S**)	CR2Q-711(-S**)/ CR2QA-711(-S**)
2	Oil mist arm extension model	RV-6SQL(-S**)	
3	Clean room basic model (Class 10)	RV-6SQC(-S**)	
4	Clean room arm extension model (Class 10)	RV-6SQLC(-S**)	
5	Oil mist basic model including oil mist model robot controller	RV-6SQ-SM6**	CR3Q-711M(-S**)
6	Oil mist arm extension model including oil mist model robot controller	RV-6SQL-SM6**	
7	UL specification oil mist basic model	RV-6SQ-SUL**	CR2Q-711-SUL**
8	UL specification oil mist arm extension model	RV-6SQL-SUL**	
9	UL specification clean room basic model (Class 10)	RV-6SQC-SUL**	
10	UL specification clean room arm extension model (Class 10)	RV-6SQLC-SUL**	
11	UL specification oil mist basic model including oil mist model robot controller	RV-6SQ-SULM6**	CR3Q-711M-SULM6**
12	UL specification oil mist arm extension model including oil mist model robot controller	RV-6SQL-SULM6**	

Table 3 : The list of RV-3SQseries robots for grouping certification; C group-1.

No.	Classification	Model name	Robot Controller
		6-axis	
1	Basic model (standard) *1	RV-3SQ-S3**	CR2Q-721-S3**/ CR2QA-721-S3**
2	Clean room basic model (standard) *1	RV-3SQC-S3**	
3	Basic model with brakes on all axis (standard)	RV-3SQB-S3**	
4	Clean room basic model with brakes on all axis (standard)	RV-3SQBC-S3**	
5	Oil mist basic model including robot controller *1	RV-3SQ-SM6**	CR3Q-721M-SM6**
6	Oil mist basic model with brakes on all axis including robot controller	RV-3SQB-SM6**	
7	UL specification and basic model with brakes on all axis (standard)	RV-3SQB-SUL3**	CR2Q-721-SUL3**
8	UL specification clean room basic model with brakes on all axis (standard)	RV-3SQBC-SUL3**	
9	UL specification oil mist basic model with brakes on all axis including robot controller	RV-3SQB-SULM6**	CR3Q-721M-SULM6**

Table 4 : The list of RV-3SQseries robots for grouping certification; C group-2.

No.	Classification	Model name	Robot Controller
		6-axis	
10	Basic model (standard) *1	RV-3SQ(-S**)	CR1QA-721(-S**)
11	Clean room basic model (standard) *1	RV-3SQC(-S**)	
12	Basic model with brakes on all axis (standard)	RV-3SQB(-S**)	
13	Clean room basic model with brakes on all axis (standard)	RV-3SQBC(-S**)	

Table 5 : The list of RV-3SQseries robots for grouping certification; C group -3.

No.	Classification	Model name	Robot Controller
		5-axis	
14	Basic model (standard) *1	RV-3SQJ-S3**	CR2Q-731-S3**/ CR2QA-731-S3**
15	Clean room basic model (standard) *1	RV-3SQJC-S3**	
16	Basic model with brakes on all axis (standard)	RV-3SQJB-S3**	
17	Clean room basic model with brakes on all axis (standard)	RV-3SQJBC-S3**	
18	Oil mist basic model including robot controller *1	RV-3SQJ-SM6**	CR3Q-731M-SM6**
19	Oil mist basic model with brakes on all axis including robot controller	RV-3SQJB-SM6**	
20	UL specification basic model with brakes on all axis (standard)	RV-3SQJB-SUL3**	CR2Q-731-SUL3**
21	UL specification clean room basic model with brakes on all axis (standard)	RV-3SQJBC-SUL3**	
22	UL specification oil mist basic model with brakes on all axis including robot controller	RV-3SQJB-SULM6**	CR3Q-731M-SULM6**

Table 6 : The list of RV-3SQseries robots for grouping certification;C group -4.

No.	Classification	Model name	Robot Controller
		5-axis	
23	Basic model (standard) *1	RV-3SQJ(-S**)	CR1QA-731(-S**)
24	Clean room basic model (standard) *1	RV-3SQJC(-S**)	
25	Basic model with brakes on all axis (standard)	RV-3SQJB(-S**)	
26	Clean room basic model with brakes on all axis (standard)	RV-3SQJBC(-S**)	

Table 7 : The list of RH-xSQH series robots for grouping certification; D group-1.

No.	Classification	Model name	Robot Controller
		6kg-Load	
1	Basic model	RH-6SQH4520-S3**	CR2Q-761 -S3**/ CR2QA-761 -S3**
2	Short arm model	RH-6SQH3520-S3**	
3	Long arm model	RH-6SQH5520-S3**	
4	Oil mist model	RH-6SQH4517M-S3**	
5	Short arm/Oil mist model	RH-6SQH3517M-S3**	
6	Long arm/Oil mist model	RH-6SQH5517M-S3**	
7	Clean room model (Class 10)	RH-6SQH4517C-S3**	
8	Short arm/Clean room model	RH-6SQH3517C-S3**	
9	Long arm/Clean room model	RH-6SQH5517C-S3**	
10	Oil mist model including R/C	RH-6SQH4517M-SM6**	CR3Q-761M -SM6**
11	Short arm/Oil mist model including R/C	RH-6SQH3517M-SM6**	
12	Long arm/Oil mist model including R/C	RH-6SQH5517M-SM6**	
13	UL specification basic model	RH-6SQH4520-SUL3**	CR2Q-761 -SUL3**
14	UL specification short arm model	RH-6SQH3520-SUL3**	
15	UL specification long arm model	RH-6SQH5520-SUL3**	
16	UL specification oil mist model	RH-6SQH4517M-SUL3**	
17	UL specification short arm/Oil mist model	RH-6SQH3517M-SUL3**	
18	UL specification long arm/Oil mist model	RH-6SQH5517M-SUL3**	
19	UL specification clean room model (Class 10)	RH-6SQH4517C-SUL3**	
20	UL specification short arm/Clean room model	RH-6SQH3517C-SUL3**	
21	UL specification long arm/Clean room model	RH-6SQH5517C-SUL3**	
22	UL specification oil mist model including R/C	RH-6SQH4517M-SULM6**	
23	UL specification short arm/Oil mist model including R/C	RH-6SQH3517M-SULM6**	
24	UL specification long arm/Oil mist model including R/C	RH-6SQH5517M-SULM6**	

Table 8 : The list of RH-xSQH series robots for grouping certification; D group-2

No.	Classification	Model name	Robot Controller
		6kg-Load	
25	Basic model	RH-6SQH4520-S**	CR1QA-761 -S**
26	Short arm model	RH-6SQH3520-S**	
27	Long arm model	RH-6SQH5520-S**	
28	Oil mist model	RH-6SQH4517M-S**	
29	Short arm/Oil mist model	RH-6SQH3517M-S**	
30	Long arm/Oil mist model	RH-6SQH5517M-S**	
31	Clean room model (Class 10)	RH-6SQH4517C-S**	
32	Short arm/Clean room model	RH-6SQH3517C-S**	
33	Long arm/Clean room model	RH-6SQH5517C-S**	

Table 9 : The list of RH-xSQH series robots for grouping certification; D group -3.

No.	Classification	Model name	Robot Controller
		12/18kg-Load	
34	Basic model	RH-12SQH7035(-S**)	CR2Q-741(-S**)/ CR2QA-741(-S**)
35	Short arm model	RH-12SQH5535(-S**)	
36	Long arm model	RH-12SQH8535(-S**)	
37	Long arm and heavy load model	RH-18SQH8535(-S**)	CR2Q-751(-S**)/ CR2QA-751(-S**)
38	Oil mist model	RH-12SQH7030M(-S**)	CR2Q-741(-S**)/ CR2QA-741(-S**)
39	Short arm/Oil mist model	RH-12SQH5530M(-S**)	
40	Long arm/Oil mist model	RH-12SQH8530M(-S**)	
41	Long arm and heavy load/Oil mist model	RH-18SQH8530M(-S**)	CR2Q-751(-S**)/ CR2QA-751(-S**)
42	Clean room model (Class 10)	RH-12SQH7030C(-S**)	CR2Q-741(-S**)/ CR2QA-741(-S**)
43	Short arm/Clean room model	RH-12SQH5530C(-S**)	
44	Long arm/Clean room model	RH-12SQH8530C(-S**)	
45	Long arm and heavy load/Clean room model (Class 10)	RH-18SQH8530C(-S**)	CR2Q-751(-S**)/ CR2QA-751(-S**)
46	Oil mist model including R/C	RH-12SQH7030M-SM6**	CR3Q-741M -SM6**
47	Short arm/Oil mist model including R/C	RH-12SQH5530M-SM6**	
48	Long arm/Oil mist model including R/C	RH-12SQH8530M-SM6**	
49	Long arm and heavy load/Oil mist model including R/C	RH-18SQH8530M-SM6**	CR3Q-751M -SM6**
50	UL specification basic model	RH-12SQH7035-SUL**	CR2Q-741-SUL**
51	UL specification short arm model	RH-12SQH5535-SUL**	
52	UL specification long arm model	RH-12SQH8535-SUL**	
53	UL specification long arm and heavy load model	RH-18SQH8535-SUL**	CR2Q-751-SUL**
54	UL specification oil mist model	RH-12SQH7030M-SUL**	CR2Q-741-SUL**
55	UL specification short arm/Oil mist model	RH-12SQH5530M-SUL**	
56	UL specification long arm/Oil mist model	RH-12SQH8530M-SUL**	
57	UL specification long arm and heavy load/Oil mist model	RH-18SQH8530M-SUL**	CR2Q-751-SUL**
58	UL specification clean room model (Class 10)	RH-12SQH7030C-SUL**	CR2Q-741-SUL**
59	UL specification short arm/Clean room model	RH-12SQH5530C-SUL**	
60	UL specification long arm/Clean room model	RH-12SQH8530C-SUL**	
61	UL specification long arm and heavy load/Clean room model (Class 10)	RH-18SQH8530C-SUL**	CR2Q-751-SUL**
62	UL specification oil mist model including R/C	RH-12SQH7030M -SULM6**	CR3Q-741M -SULM6**
63	UL specification short arm/Oil mist model including R/C	RH-12SQH5530M -SULM6**	
64	UL specification long arm/Oil mist model including R/C	RH-12SQH8530M -SULM6**	
65	UL specification long arm and heavy load/Oil mist model including R/C	RH-18SQH8530M -SULM6**	CR3Q-751M -SULM6**

Table 10 : The list of robots for grouping certification; D group -4 .

No.	Classification	Model name	Robot Controller
		6kg-Load	
57	Z-Stroke variation , Basic model	RH-6SQH4532(-S**)	CR1QA-761 (-S**)
58	Z-Stroke variation , Short arm model	RH-6SQH3532(-S**)	
59	Z-Stroke variation , Long arm model	RH-6SQH5532(-S**)	
60	Z-Stroke variation , Oil mist model	RH-6SQH4527M(-S**)	
61	Z-Stroke variation , Short arm/Oil mist model	RH-6SQH3527M(-S**)	
62	Z-Stroke variation , Long arm/Oil mist model	RH-6SQH5527M(-S**)	
63	Z-Stroke variation , Clean room model (Class 10)	RH-6SQH4527C(-S**)	
64	Z-Stroke variation , Short arm/Clean room model	RH-6SQH3527C(-S**)	
65	Z-Stroke variation , Long arm/Clean room model	RH-6SQH5527C(-S**)	

RV-3SQ is the test models.

Table 11 : The list of robots for grouping certification; D group-5.

No.	Classification	Model name	Robot Controller
		6kg-Load	
75	Z-Stroke variation , Basic model	RH-6SQH4532-S3**	CR2QA-761 -S3**
76	Z-Stroke variation , Short arm model	RH-6SQH3532-S3**	
77	Z-Stroke variation , Long arm model	RH-6SQH5532-S3**	
78	Z-Stroke variation , Oil mist model	RH-6SQH4527M-S3**	
79	Z-Stroke variation , Short arm/Oil mist model	RH-6SQH3527M-S3**	
80	Z-Stroke variation , Long arm/Oil mist model	RH-6SQH5527M-S3**	
81	Z-Stroke variation , Clean room model (Class 10)	RH-6SQH4527C-S3**	
82	Z-Stroke variation , Short arm / Clean room model	RH-6SQH3527C-S3**	
83	Z-Stroke variation , Long arm / Clean room model	RH-6SQH5527C-S3**	
84	Z-Stroke variation , Oil mist model including R/C	RH-6SQH4527M-SM6**	CR3Q-761M -SM6**
85	Z-Stroke variation , Short arm/Oil mist model including R/C	RH-6SQH3527M-SM6**	
86	Z-Stroke variation , Long arm/Oil mist model including R/C	RH-6SQH5527M-SM6**	
87	Z-Stroke variation , UL specification basic model	RH-6SQH4532-SUL3**	CR2Q-761 -SUL3**
88	Z-Stroke variation , UL specification short arm model	RH-6SQH3532-SUL3**	
89	Z-Stroke variation , UL specification long arm model	RH-6SQH5532-SUL3**	
90	Z-Stroke variation , UL specification oil mist model	RH-6SQH4527M-SUL3**	
91	Z-Stroke variation , UL specification short arm /Oil mist model	RH-6SQH3527M-SUL3**	
92	Z-Stroke variation , UL specification long arm /Oil mist model	RH-6SQH5527M-SUL3**	
93	Z-Stroke variation , UL specification clean room model (Class 10)	RH-6SQH4527C-SUL3**	
94	Z-Stroke variation , UL specification short arm /Clean room model	RH-6SQH3527C-SUL3**	
95	Z-Stroke variation , UL specification long arm /Clean room model	RH-6SQH5527C-SUL3**	
96	Z-Stroke variation , UL specification oil mist model including R/C	RH-6SQH4527M-SULM6**	CR3Q-761M -SULM6**
97	Z-Stroke variation , UL specification short arm /Oil mist model including R/C	RH-6SQH3527M-SULM6**	
98	Z-Stroke variation , UL specification long arm /Oil mist model including R/C	RH-6SQH5527M-SULM6**	

RV-12SQL-SUL** and **RV-6SQL-SUL**** are the tested models.

Table 12 : The list of RH-xSQH robots for grouping certification; D group -6.

No.	Classification	Model name	Robot Controller
		12/18kg-Load	
99	Z-Stroke variation , Basic model	RH-12SQH7045(-S**)	CR2QA-741(-S**)
100	Z-Stroke variation , Short arm model	RH-12SQH5545(-S**)	
101	Z-Stroke variation , Long arm model	RH-12SQH8545(-S**)	
102	Z-Stroke variation , Oil mist model	RH-12SQH7038M(-S**)	
103	Z-Stroke variation , Short arm/Oil mist model	RH-12SQH5538M(-S**)	
104	Z-Stroke variation , Long arm/Oil mist model	RH-12SQH8538M(-S**)	
105	Z-Stroke variation , Clean room model (Class 10)	RH-12SQH7038C(-S**)	
85	Z-Stroke variation , Short arm/Clean room model	RH-12SQH5538C(-S**)	
86	Z-Stroke variation , Long arm/Clean room model	RH-12SQH8538C(-S**)	
87	Z-Stroke variation , Oil mist model including R/C	RH-12SQH7038M-SM6**	CR3Q-741M -SM6**
88	Z-Stroke variation , Short arm/Oil mist model including R/C	RH-12SQH5538M-SM6**	
89	Z-Stroke variation , Long arm/Oil mist model including R/C	RH-12SQH8538M-SM6**	
90	Z-Stroke variation , UL specification basic model	RH-12SQH7045-SUL**	CR2Q-741-SUL**
91	Z-Stroke variation , UL specification short arm model	RH-12SQH5545-SUL**	
92	Z-Stroke variation , UL specification long arm model	RH-12SQH8545-SUL**	
93	Z-Stroke variation , UL specification oil mist model	RH-12SQH7038M-SUL**	
94	Z-Stroke variation , UL specification short arm /Oil mist model	RH-12SQH5538M-SUL**	
95	Z-Stroke variation , UL specification long arm/Oil mist model	RH-12SQH8538M-SUL**	
96	Z-Stroke variation , UL specification clean room model (Class 10)	RH-12SQH7038C-SUL**	
97	Z-Stroke variation , UL specification short arm /Clean room model	RH-12SQH5538C-SUL**	
98	Z-Stroke variation , UL specification long arm/Clean room model	RH-12SQH8538C-SUL**	
99	Z-Stroke variation , UL specification oil mist model including R/C	RH-12SQH7038M -SULM6**	CR3Q-741M -SULM6**
100	Z-Stroke variation , UL specification short arm /Oil mist model including R/C	RH-12SQH5538M -SULM6**	
101	Z-Stroke variation , UL specification long arm/Oil mist model including R/C	RH-12SQH8538M -SULM6**	

Table 13 : The list of RH-xSQH robots for grouping certification; D group -7.

No.	Classification	Model name	Robot Controller
		20kg-Load	
102	Heavy load variation , Basic model	RH-20SQH8545 (-S**)	CR2QA-751(-S**)
103	Heavy load variation , Short Z-Stroke model	RH-20SQH8535(-S**)	
104	Heavy load variation , Long arm model	RH-20SQH10045(-S**)	
105	Heavy load variation , Long arm and Short Z-Stroke model	RH-20SQH10035(-S**)	
106	Heavy load variation / Oil mist model	RH-20SQH8538M(-S**)	
107	Heavy load variation , Short Z-Stroke /Oil mist model	RH-20SQH8530M(-S**)	
108	Heavy load variation , Long Arm /Oil mist model	RH-20SQH10038M(-S**)	
109	Heavy load variation , Long arm and Short Z-Stroke /Oil mist model	RH-20SQH10030M(-S**)	
110	Heavy load variation /Clean room model	RH-20SQH8538C(-S**)	
111	Heavy load variation , Short Z-Stroke /Clean room model	RH-20SQH8530C(-S**)	
112	Heavy load variation, Long arm /Clean room model	RH-20SQH10038C(-S**)	
113	Heavy load variation , Long arm and Short Z-Stroke /Clean room model	RH-20SQH10030C(-S**)	
114	Heavy load variation / Oil mist model including R/C	RH-20SQH8538M-SM6**	
115	Heavy load variation , Short Z-Stroke /Oil mist model including R/C	RH-20SQH8530M-SM6**	
116	Heavy load variation , Long Arm /Oil mist model including R/C	RH-20SQH10038M-SM6**	
117	Heavy load variation , Long arm and Short Z-Stroke /Oil mist model including R/C	RH-20SQH10030M-SM6**	
118	Heavy load variation , Basic model	RH-20SQH8545 -SUL**	CR2Q-751 -SUL**
119	Heavy load variation , Short Z-Stroke model	RH-20SQH8535-SUL**	
120	Heavy load variation , Long arm model	RH-20SQH10045-SUL**	
121	Heavy load variation , Long arm and Short Z-Stroke model	RH-20SQH10035-SUL**	
122	Heavy load variation / Oil mist model	RH-20SQH8538M-SUL**	
123	Heavy load variation , Short Z-Stroke /Oil mist model	RH-20SQH8530M-SUL**	
124	Heavy load variation , Long Arm /Oil mist model	RH-20SQH10038M-SUL**	
125	Heavy load variation , Long arm and Short Z-Stroke /Oil mist model	RH-20SQH10030M-SUL**	
126	Heavy load variation /Clean room model	RH-20SQH8538C-SUL**	
127	Heavy load variation , Short Z-Stroke /Clean room model	RH-20SQH8530C-SUL**	
128	Heavy load variation, Long arm /Clean room model	RH-20SQH10038C-SUL**	
129	Heavy load variation , Long arm and Short Z-Stroke /Clean room model	RH-20SQH10030C-SUL**	
130	Heavy load variation / Oil mist model including R/C	RH-20SQH8538M-SULM6**	CR3Q-751M -SULM6**
131	Heavy load variation , Short Z-Stroke /Oil mist model including R/C	RH-20SQH8530M-SULM6**	
132	Heavy load variation , Long Arm /Oil mist model including R/C	RH-20SQH10038M-SULM6**	
133	Heavy load variation , Long arm and Short Z-Stroke /Oil mist model including R/C	RH-20SQH10030M-SULM6**	

Table 14 : The list of RV-2SQ series robots for grouping certification; E group.

No.	Classification	Model name	Robot Controller
		6-axis	
1	Basic model (standard) *1	RV-2SQ(-S**)	CR1QA-771(-S**)
2	Basic model with brakes on all axis	RV-2SQB(-S**)	CR1QA-772(-S**)
3	Special machine cable model *1	RV-2SQ-S12	CR1QA-771-S12
4	Special machine cable model with brakes on all axis	RV-2SQB-S12	CR1QA-772-S12

Table 15 : The list of RH-3SQHR series robots for grouping certification; F group -1.

No.	Classification	Model name	Robot Controller
		4-axis	
1	Basic model (standard)	RH-3SQHR3515W(-S**)	CR2QA-781(-S**)
2	Special machine cable model	RH-3SQHR3515N (-S**)	CR1QA-781(-S**)
3	Oil mist model	RH-3SQHR3512MW (-S**)	CR2QA-781(-S**)
4	Oil mist model including R/C	RH-3SQHR3512MW -SM6**	CR3Q-781M-SM6**
5	Long arm model	RH-3SQHR5515W(-S**)	CR2QA-781(-S**)
6	Special machine cable model, Long arm type	RH-3SQHR5515N (-S**)	CR1QA-781(-S**)
7	Oil mist model , Long arm type	RH-3SQHR5512MW (-S**)	CR2QA-781(-S**)
8	Oil mist model including R/C, Long arm type	RH-3SQHR5512MW -SM6**	CR3Q-781M-SM6**
9	UL specific type	RH-3SQHR3515W-SUL**	CR2QA-781-SUL**
10	Oil mist model, UL specific type	RH-3SQHR3512MW-SUL**	CR2QA-781-SUL**
11	Oil mist model including R/C,UL specific model	RH-3SQHR3512MW -SULM6**	CR3Q-781M-SULM6**
12	Long arm model ,UL specific type	RH-3SQHR5515W-SUL**	CR2QA-781-SUL**
13	Oil mist model , Long arm and UL specific type	RH-3SQHR5512MW -SUL**	CR2QA-781-SUL**
14	Oil mist model including R/C, Long arm and UL specific type	RH-3SQHR5512MW -SULM6**	CR3Q-781M-SULM6**
15	Basic model, regular type	RH-3SQHR3515(-S**)	CR2QA-781(-S**)
16	Oil mist model , regular type	RH-3SQHR3512M (-S**)	CR2QA-781(-S**)
17	Oil mist model including R/C, regular type	RH-3SQHR3512M -SM6**	CR3Q-781M-SM6**
18	Long arm model, regular type	RH-3SQHR5515(-S**)	CR2QA-781(-S**)
19	Oil mist model , Long arm type, regular type	RH-3SQHR5512M (-S**)	CR2QA-781(-S**)
20	Oil mist model including R/C, Long arm type regular type	RH-3SQHR5512M -SM6**	CR3Q-781M-SM6**
21	UL specific type, regular type	RH-3SQHR3515-SUL**	CR2QA-781-SUL**
22	Oil mist model, UL specific type regular type	RH-3SQHR3512M-SUL**	CR2QA-781-SUL**
23	Oil mist model including R/C,UL specific model regular type	RH-3SQHR3512M-SULM6**	CR3Q-781M-SULM6**
24	Long arm model ,UL specific type	RH-3SQHR5515-SUL**	CR2QA-781-SUL**
25	Oil mist model , Long arm and UL specific type regular type	RH-3SQHR5512M-SUL**	CR2QA-781-SUL**
26	Oil mist model including R/C, Long arm and UL specific type regular type	RH-3SQHR5512M-SULM6**	CR3Q-781M-SULM6**
27	Water proof model , regular type	RH-3SQHR3512W (-S**)	CR2QA-781(-S**)
28	Clean room model (ISO Class 5), regular type	RH-3SQHR3512C (-S**)	CR2QA-781(-S**)
29	Water proof model including R/C, regular type	RH-3SQHR3512W -SM6**	CR3Q-781M-SM6**

Table 16 : The list of RH-3SQHR series robots for grouping certification; F group -2.

No.	Classification	Model name	Robot Controller
		4-axis	
30	Water proof model, UL specific type regular type	RH-3SQHR3512W -SUL**	CR2QA-781-SUL**
31	Clean room model (ISO Class 5), UL specific type regular type	RH-3SQHR3512C-SUL**	CR2QA-781-SUL**
32	Water proof model including R/C,UL specific model regular type	RH-3SQHR3512W-SULM6**	CR3Q-781M-SULM6**
33	Water proof model , Long arm type, regular type	RH-3SQHR5512W (-S**)	CR2QA-781(-S**)
34	Clean room model (ISO Class 5), Long arm type, regular type	RH-3SQHR5512C (-S**)	CR2QA-781(-S**)
35	Water proof model including R/C, Long arm type, regular type	RH-3SQHR5512W -SM6**	CR3Q-781M-SM6**
36	Water proof model, Long arm and UL specific type regular type	RH-3SQHR5512W -SUL**	CR2QA-781-SUL**
37	Clean room model (ISO Class 5), Long arm and UL specific type regular type	RH-3SQHR5512C-SUL**	CR2QA-781-SUL**
38	Water proof model including R/C, Long arm and UL specific model regular type	RH-3SQHR5512W-SULM6**	CR3Q-781M-SULM6**

Revision history

Date	Specifications No.	Details of revisions	Rev.
July 1, 2009		First print	*
October 13, 2009	P1	Standards update(2006/42/EC)	A
April 7, 2010	P7	RV-2SQseries added	B
May 11, 2010	P4, P5	RV-3SQ-Sxx series added RH-6SQH-Sxx series added	C
July 2, 2010	P3 P3-P7	Added RV-12SQ-S3** series Added CR2QA-7** controller	D
September 3, 2010	P8-11	Added RH-xSQH series ,Arm length,Z-Stroke,and Heavy load models	E
October 1, 2010	P12	Added RH-3SQHR series	F
November 9, 2010	P13	Added RH-3SQHR series No.15-No.25	G
January 26, 2012	P1	Changed ISO10218-1 from 2006 version to 2011 version	H
February 20, 2012	P13, 14	Added variation models(No.27 to 38) to RH-3SQHR series	J

사용자안내문 User's Guide

기종별 Type of Equipment	사용자안내문 User's Guide
<p>A 급 기기 (업무용 방송통신기자재)</p> <p>Class A Equipment (Industrial Broadcasting & Communication Equipment)</p>	<p>이 기기는 업무용(A 급) 전자파적합기기로서 판매자 또는 사용자는 이 점을 주의하시기 바라며, 가정외의 지역에서 사용하는 것을 목적으로 합니다.</p> <p>This equipment is Industrial (Class A) electromagnetic wave suitability equipment and seller or user should take notice of it, and this equipment is to be used in the places except for home.</p>
<p>B 급 기기 (가정용 방송통신기자재)</p> <p>Class B Equipment (For Home Use Broadcasting & Communication Equipment)</p>	<p>이 기기는 가정용(B 급) 전자파적합기기로서 주로 가정에서 사용하는 것을 목적으로 하며, 모든 지역에서 사용할 수 있습니다.</p> <p>This equipment is home use (Class B) electromagnetic wave suitability equipment and to be used mainly at home and it can be used in all areas.</p>

HEADQUARTERS

MITSUBISHI ELECTRIC EUROPE B.V. German Branch Gothaer Straße 8 D-40880 Ratingen Phone: +49 (0)2102 / 486-0 Fax: +49 (0)2102 / 486-1120	EUROPE
MITSUBISHI ELECTRIC EUROPE B.V.-org.sl. Czech Branch Avenir Business Park, Radlická 714/113a CZ-158 00 Praha 5 Phone: +420 (0)251-551 470 Fax: +420 (0)251-551-471	CZECH REP.
MITSUBISHI ELECTRIC EUROPE B.V. French Branch 25, Boulevard des Bouvets F-92741 Nanterre Cedex Phone: +33 (0)1 / 55 68 55 68 Fax: +33 (0)1 / 55 68 57 57	FRANCE
MITSUBISHI ELECTRIC EUROPE B.V. Irish Branch Westgate Business Park, Ballymount IRL-Dublin 24 Phone: +353 (0)1 4198800 Fax: +353 (0)1 4198890	IRELAND
MITSUBISHI ELECTRIC EUROPE B.V. Italian Branch Viale Colleoni 7 I-20041 Agrate Brianza (MB) Phone: +39 039 / 60 53 1 Fax: +39 039 / 60 53 312	ITALY
MITSUBISHI ELECTRIC EUROPE B.V. Poland Branch Krakowska 50 PL-32-083 Balice Phone: +48 (0)12 / 630 47 00 Fax: +48 (0)12 / 630 47 01	POLAND
MITSUBISHI ELECTRIC EUROPE B.V. 52, bid. 3 Kosmodamianskaya nab 8 floor RU-115054 Moscow Phone: +7 495 721-2070 Fax: +7 495 721-2071	RUSSIA
MITSUBISHI ELECTRIC EUROPE B.V. Spanish Branch Carretera de Rubí 76-80 E-08190 Sant Cugat del Vallés (Barcelona) Phone: 902 131121 // +34 935653131 Fax: +34 935891579	SPAIN
MITSUBISHI ELECTRIC EUROPE B.V. UK Branch Travellers Lane UK-Hatfield, Herts. AL10 8XB Phone: +44 (0)1707 / 27 61 00 Fax: +44 (0)1707 / 27 86 95	UK
MITSUBISHI ELECTRIC CORPORATION Office Tower "Z" 14 F 8-12,1 chome, Harumi Chuo-Ku Tokyo 104-6212 Phone: +81 3 622 160 60 Fax: +81 3 622 160 75	JAPAN
MITSUBISHI ELECTRIC AUTOMATION, Inc. 500 Corporate Woods Parkway Vernon Hills, IL 60061 Phone: +1 847 478 21 00 Fax: +1 847 478 22 53	USA

EUROPEAN REPRESENTATIVES

GEVA Wiener Straße 89 AT-2500 Baden Phone: +43 (0)2252 / 85 55 20 Fax: +43 (0)2252 / 488 60	AUSTRIA
Koning & Hartman b.v. Woluwelaan 31 BE-1800 Vilvoorde Phone: +32 (0)2 / 257 02 40 Fax: +32 (0)2 / 257 02 49	BELGIUM
INEA RBT d.o.o. Aleja Lipa 56 BA-71000 Sarajevo Phone: +387 (0)33 / 921 164 Fax: +387 (0)33 / 524 539	BOSNIA AND HERZEGOVINA
AKHNATON 4, Andrei Ljapchev Blvd., PO Box 21 BG-1756 Sofia Phone: +359 (0)2 / 817 6000 Fax: +359 (0)2 / 97 44 06 1	BULGARIA
AutoCont C.S. s.r.o. Technologická 374/6 CZ-708 00 Ostrava-Pustkovec Phone: +420 595 691 150 Fax: +420 595 691 199	CZECH REPUBLIC
Beijer Electronics A/S Lykkegårdsvej 17 DK-4000 Roskilde Phone: +45 (0)46 / 75 76 66 Fax: +45 (0)46 / 75 56 26	DENMARK
Beijer Electronics OY Peltoie 37 FIN-28400 Ulvila Phone: +358 (0)207 / 463 540 Fax: +358 (0)207 / 463 541	FINLAND
UTEKO 5, Mavrogenous Str. GR-18542 Piraeus Phone: +30 211 / 1206 900 Fax: +30 211 / 1206 999	GREECE
AXICONT AUTOMATIKA Kft. (ROBOT CENTER) Reitter F. U. 132 HU-1131 Budapest Phone: +36 1 / 412-0882 Fax: +36 1 / 412-0883	HUNGARY
ALFATRADE Ltd. 99, Paola Hill Malta- Paola PLA 1702 Phone: +356 (0)21 / 697 816 Fax: +356 (0)21 / 697 817	MALTA
HIFLEX AUTOM. TECHNIK B.V. Wolweverstraat 22 NL-2984 CD Ridderkerk Phone: +31 (0)180 - 46 60 04 Fax: +31 (0)180 - 44 23 55	NETHERLANDS

EUROPEAN REPRESENTATIVES

Koning & Hartman b.v. Haarlerbergweg 21-23 NL-1101 CH Amsterdam Phone: +31 (0)20 / 587 76 00 Fax: +31 (0)20 / 587 76 05	NETHERLANDS
Beijer Electronics AS Postboks 487 NO-3002 Drammen Phone: +47 (0)32 / 24 30 00 Fax: +47 (0)32 / 84 85 77	NORWAY
Fonseca S.A. R. João Francisco do Casal 87/89 PT - 3801-997 Aveiro, Esigueira Phone: +351 (0)234 / 303 900 Fax: +351 (0)234 / 303 910	PORTUGAL
SIRIUS TRADING & SERVICES SRL Aleea Lacul Morii Nr. 3 RO-060841 Bucuresti, Sector 6 Phone: +40 (0)21 / 430 40 06 Fax: +40 (0)21 / 430 40 02	ROMANIA
INEA RBT d.o.o. Izletnicka 10 SER-113000 Smederevo Phone: +381 (0)26 / 615 401 Fax: +381 (0)26 / 615 401	SERBIA
SIMAP s.r.o. Jána Derku 1671 SK-911 01 Trenčín Phone: +421 (0)32 743 04 72 Fax: +421 (0)32 743 75 20	SLOVAKIA
PROCONT, spol. s r.o. Prešov Kúpeľná 1/A SK-080 01 Prešov Phone: +421 (0)51 7580 611 Fax: +421 (0)51 7580 650	SLOVAKIA
INEA RBT d.o.o. Stegne 11 SI-1000 Ljubljana Phone: +386 (0)1 / 513 8116 Fax: +386 (0)1 / 513 8170	SLOVENIA
Beijer Electronics Automation AB Box 426 SE-20124 Malmö Phone: +46 (0)40 / 35 86 00 Fax: +46 (0)40 / 93 23 01	SWEDEN
Robotronic AG Schlachthofstrasse 8 CH-8406 Winterthur Phone: +41 (0)52 / 267 02 00 Fax: +41 (0)52 / 267 02 01	SWITZERLAND
GTS Bayraktar Bulvari Nutuk Sok. No:5 TR-34775 Yukarı Dudullu-Ümraniye-İSTANBUL Phone: +90 (0)216 526 39 90 Fax: +90 (0)216 526 3995	TURKEY
CSC Automation Ltd. 4-B, M. Raskovoyi St. UA-02660 Kiev Phone: +380 (0)44 / 494 33 55 Fax: +380 (0)44 / 494-33-66	UKRAINE

MIDDLE EAST REPRESENTATIVE

I.C. SYSTEMS LTD. 23 Al-Saad-Al-Alee St. EG-Saray, Maadi, Cairo Phone: +20 (0) 2 / 235 98 548 Fax: +20 (0) 2 / 235 96 625	EGYPT
ILAN & GAVISH Ltd. 24 Shenkar St., Kiryat Arie IL-49001 Petah-Tiqva Phone: +972 (0)3 / 922 18 24 Fax: +972 (0)3 / 924 0761	ISRAEL

AFRICAN REPRESENTATIVE

CBI Ltd. Private Bag 2016 ZA-1600 Isando Phone: + 27 (0)11 / 977 0770 Fax: + 27 (0)11 / 977 0761	SOUTH AFRICA
--	---------------------