

# RH-FH Series

## Industrial robots

**Intelligent solutions**  
for complex manufacturing processes



0.29 s 12" cycle time enables high-precision, high-performance applications to be used to increase on-site productivity



IP54 and food-grade grease for full integration



Fully enclosed cabling to end of spindle for protection and safety



Fitted with many interfaces such as Ethernet, USB, camera interface, additional axis controller, hand I/O etc. as standard

# More productivity and efficiency



Speed and easy integration allow wide-ranging applications.

## The fastest in their class

The robots of the RH-F series achieve the highest speeds in their class thanks to the new motors developed by Mitsubishi Electric, high arm rigidity and unique control technology. The resulting reduced cycle time of only 0.29 seconds for a 12" cycle make for significantly increased productivity and improved continuous operation.

The dramatically extended movement range ensures more flexibility and thus simplifies system planning. Effective access to the entire, almost circular working range has many advantages: it reduces cycle times by avoiding unnecessary movements and increases the tasks which the robot can perform in its working range.

## Easy integration and application

It makes no difference whether you are modernising your manufacturing system or setting it up for the first time. Straight from the factory, the RH-F series offers many features which are only available as optional extras on comparable products. For example, every model has connections for pneumatic grippers, Ethernet, USB, tracking functions, camera interface, hand I/O, additional axis controller and an interface for GOT HMIs with freely programmable user interfaces. The standard grease is food-grade H1 grease – ideal for the food and beverage industry. An ISO Level III clean-room model is also available for pharmaceutical and microelectronics applications.

Even the RH-3FH entry-level model is equally well equipped, and with a load capacity of 3 kg is suitable for most applications. Anyone requiring to move heavier loads can call upon the top-of-the-range RH-6/20FH with a maximum load capacity of 20 kg. The RH-6/12/20FH has the tried-and-tested protection class IP54 for industrial systems which protects against dust and spray water. For use in particularly contaminated or dusty environments, the model can be retrospectively upgraded to IP65 at relatively little cost and without any problems thanks to the closed housing concept.



The RH-F series is supported by high-performance controllers.

## Forward-looking, fascinating and flexible

When it comes to their modern production systems, companies are placing increasing importance on high production speeds and efficient integration into existing systems as well as a full range of connection options. Characteristics which are easily fulfilled by the Mitsubishi Electric RH-F series in a forward-looking, flexible and fascinating manner.

Mitsubishi Electric SCARA robots are used wherever maximum precision is required. The innovative Mitsubishi Electric MELFA robots are known for their wide-ranging applications, whether for fast palletising, accurate sorting or parts assembly. The RH-F series also confirms this approach. These SCARA robots are suitable for a variety of industrial applications straight from the factory and without the need to purchase additional modules.

## Wide-ranging applications

The RH-F series is a range of robust, high-quality robots with an outstanding price/performance ratio. They are suitable straight from the factory for a wide range of industrial applications and can be deployed in many industries. Examples include industrial sectors such as food and beverage, packaging, laboratory automation, automobile manufacturing and cell manufacturing. In addition, MELFA RH-F robots can be easily and cost-effectively adapted to suit most requirements and situations.

## More safety

When several robots are used in one work cell, a CPU connection between the controllers ensures that individual robots are controlled in a co-ordinated manner. They can be operated individually as easily as in normal operation.

In jog or automatic mode, an anti-collision function ensures that robots are stopped in good time before they can collide, thus preventing damage. This avoids additional expensive working time for carrying out repairs following a collision due to incorrect position information or wrongly set interlocks.

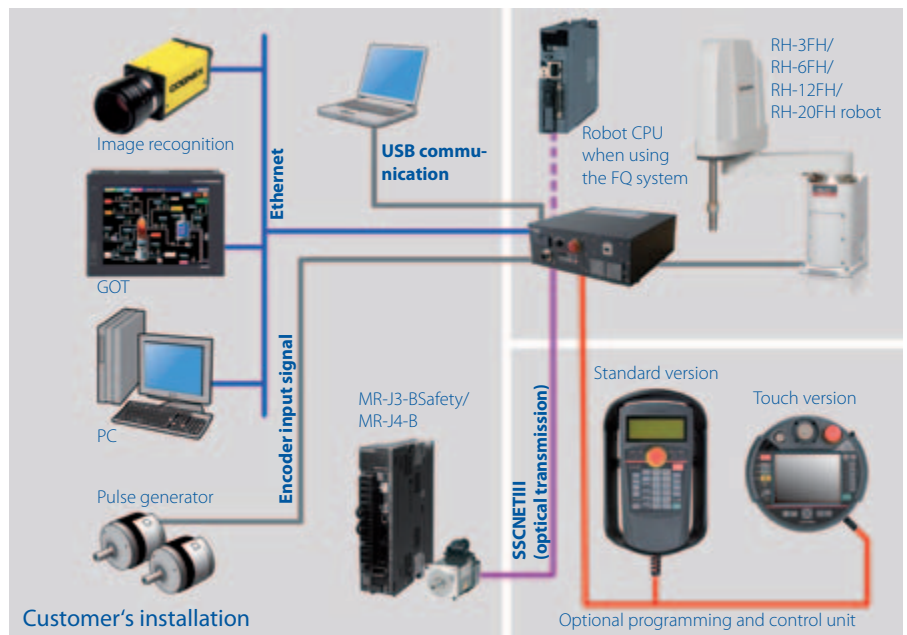

Standard robot control interfaces

## Advanced programming

A further advantage is the quick and easy commissioning via PC. Models of the RH-F series can be quickly and easily programmed using the supplied RT ToolBox2 software.

The RT ToolBox2 programming software's graphical interface enables imported 3D CAD files, program variables and robot simulations to be displayed quickly and easily.

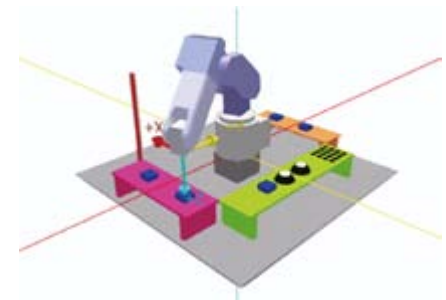

Simulation with CAD data

## Movement range and dimensions

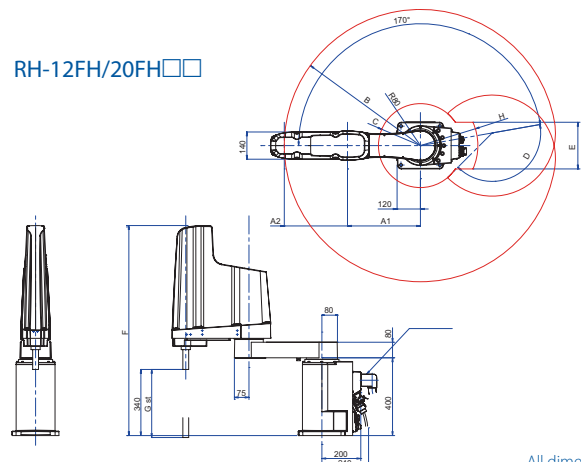
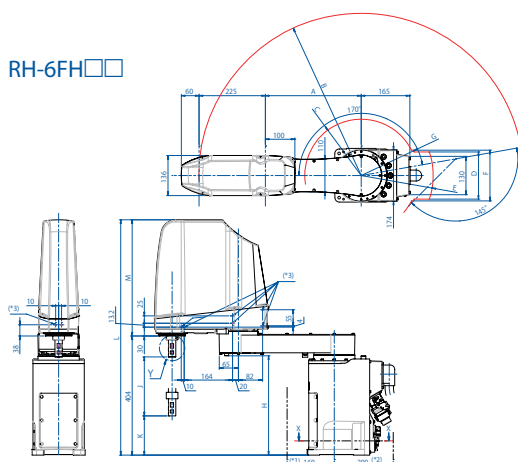

All dimensions in mm

Dimensions for type	A	A1	A2	B	C	D	E	F	G	H	J	K	L	M
RH-6FH5520-S15	325	—	—	R550	R191	160	R244	172	R197	337	200	133	798	386
RH-12FH/20FH8535-S15	—	525	325	R850	R278	153°	—	1080/1180	350/450	—	—	—	—	—

The shown data in the table are only an extract of all data about standard reach arms.

# Specifications

Robot	RH-3FH 5515-S15	RH-6FH 5520-S15	RH-12FH 8535N-S15	RH-20FH 8535N-S15		
Installation	Floor mounting					
Degrees of freedom	4					
Design	Horizontal articulated arm (SCARA)					
Drive system	AC servo motor					
Position detection method	Absolute encoder					
Arm length	Arm 1	mm	325	525		
	Arm 2	mm	225	325		
Max. working range (Arm 1 + Arm 2)	mm	550	850			
Maximum speed	J1-axis	deg/s	420	400	250	
	J2-axis	deg/s	720	670	450	
	J3(Z)-axis	mm/s	1100	2400	2800	2400
	J4(θ)-axis	deg/s	3000	2500	2400	1700
Maximum composite speed	mm/s	8300		11350	11372	
Cycle time (with 2 kg load)	s	0.41	0.29	0.30		
Lifting capacity	Nominal	kg	1	3	3	5
	Maximum	kg	3	6	12	20
Repeat accuracy	X-,Y-direction	mm	±0.012		±0.015	
	J3(Z)-axis	mm	±0.010			
	J4(θ)-axis	deg	±0.004		±0.005	
Operating temperature	°C	0–40				
Weight	kg	32	37	69	75	
Tool wiring	Hand: 8 inputs/8 outputs (20 pins total) Serial signal cable for parallel I/O (2-pin and 2 pins for power supply) LAN 100BASE-TX (RJ45)					
Tool pneumatic pipes	Primary: Ø6 x 2, Secondary: Ø4 x 8					
Protection class	IP20	IP54 (IP65 optional)				
Compatible robot controller*	CR750-D/Q					

\* Select the control unit suitable for your application.  
CR750-D: Stand-alone unit, CR750-Q: Unit for incorporating in iQ Platform.

Robot controller	CR750-Q	CR750-D	
Programming language	MELFA-BASIC V		
Position determination	Teaching, manual data input (MDI)		
General-purpose I/O	up to 8192	up to 256	
	Dedicated I/O	Common I/O for multiple CPU	User-defined
External I/O	Gripper status signal inputs		8 inputs
	External emergency stop		1 (redundant)
	Door closed contact		1 (redundant)
	Enabling switch		1 (redundant)
	Emergency stop additional axes		1 (redundant)
Interfaces	RS422	1 (Teaching Box)	
	Ethernet	1 (Teaching Box)	1 (Teaching Box) 1 (spare) 10BASE-T/100BASE-TX
	USB	1 (USB port for PLC CPU)	1 (Mini-B connector, Ver. 2.0)
	Additional axis	up to 8 (SSCNETIII)	
	Conveyor belt tracking encoder	Q173DPX (optional)	2
	Expansion slot	—	2
	Power supply	Input voltage	Single phase 180 V to 253 V AC ①
Power consumption kVA ②		2.0	
Ambient temperature	°C	0–40 (drive unit)/ 0–55 (robot CPU)	0–40
Dimensions (WxHxD)	mm	430x425x174	
Weight	kg	approx. 20	
Housing/protection class	Floor mounting/IP20		

① The supply voltage should not vary by more than 10%.  
② Without switch-on current.

## European Branches

Mitsubishi Electric Europe B.V. Gothaer Straße 8 D-40880 Ratingen Phone: +49 (0)2102 / 486-0	Germany
Mitsubishi Electric Europe B.V.-org.srl Radická 714/113a CZ-158 00 Praha 5 Phone: +420-251 551 470	Czech Rep.
Mitsubishi Electric Europe B.V. 25, Boulevard des Bouvets F-92741 Nanterre Cedex Phone: +33 (0)1 / 55 68 55 68	France
Mitsubishi Electric Europe B.V. Viale Colonna 7 I-20041 Agrate Brianza (MB) Phone: +39 039 / 60 53 1	Italy
Mitsubishi Electric Europe B.V. Kraakowska 50 PL-32-083 Balice Phone: +48 (0)12 / 630 47 00	Poland
Mitsubishi Electric Europe B.V. 52, bld. 3 Kosmodamienskaya nab 8 floor RU-115054 Moscow Phone: +7 495 721-2070	Russia
Mitsubishi Electric Europe B.V. Carretera de Rubí 76-80 E-08190 Sant Cugat del Valles (Barcelona) Phone: 902 131121 / +34 935653131	Spain
Mitsubishi Electric Europe B.V. Travellers Lane UK-Hatfield, Herts. AL10 8XB Phone: +44 (0)1707 / 27 61 00	UK

## Representatives

GEVA Wiener Straße 89 AT-2500 Baden Phone: +43 (0)2252 / 85 55 20	Austria	UTEKO S, Mavrogenous Str. GR-18542 Piraeus Phone: +30 211 / 1206 900	Greece	Fonseca S.A. R. João Francisco do Casal 87/89 PT - 3801-997 Aveiro, Esqueira Phone: +351 (0)234 / 303 900	Portugal	PROCONT, spol. s r.o. Prešov Kúpeľná 1/A SK-080 01 Prešov Phone: +421 (0)51 7580 611	Slovakia	Robotronic AG Schlachthofstrasse 8 CH-8406 Winterthur Phone: +41 (052) / 267 02 00	Switzerland	I.C. SYSTEMS LTD. 23 Al-Saad-Al-Alee St. EG - Sarayat, Maadi, Cairo Phone: +20 (0) 2 / 235 98 548	Egypt
Koning & Hartman b.v. Woluwelaan 31 BE-1800 Vilvoorde Phone: +32 (0)2 / 257 02 40	Belgium	AXICONT AUTOMATIKA Kft. Reitter F. U. 132 HU-1131 Budapest Phone: +36 (0)1 / 412-0882	Hungary	SIRIUS T & S SRL Aleea Lacul Morii Nr. 3 RO-060841 Bucuresti, Sector 6 Phone: +40 (0)21 / 430 40 06	Romania	INEAR RBT d.o.o. Stegne 11 SI-1000 Ljubljana Phone: +386 (0)1 / 513 8116	Slovenia	GTS Bayraktar Bulvarı Nutuk Sok. No:5 TR-34775 Yukarı İSTANBUL Phone: +90 (0)216 526 39 90	Turkey	ILAN & GAVISH Ltd. 24 Shenkar St., Kiryat Anie IL-49001 Petah-Tiqva Phone: +972 (0)3 / 922 18 24	Israel
INEAR RBT d.o.o. Aleja Lipa 56 BA-71000 Sarajevo Phone: +387 (0)33 / 921 164	Bosnia and Herzeg.	ALFATRADE Ltd. 99, Paola Hill Malta-Paola PLA 1702 Phone: +356 (0)21 / 697 816	Malta	INEAR RBT d.o.o. Izletnicka 10 SER-113000 Smederevo Phone: +381 (0)26 / 615 401	Serbia	Bejeer Electronics AB Box 426 SE-20124 Malmö Phone: +46 (0)40 / 35 86 00	Sweden	CSC Automation Ltd. 4-B, M. Raskovoyi St. UA-02660 Kiev Phone: +380 (0)44 / 494 33 55	Ukraine	CBI Ltd. Private Bag 2016 ZA-1600 Isando Phone: 27 (0)11 / 977 0770	South Africa
AKHNATON 4, Andrei Lipachev Blvd., PO Box 21 BG-1756 Sofia Phone: +359 (0)2 / 817 6000	Bulgaria	HIFLEX AUTOM. B.V. Wolweverstraat 22 NL-2984 CD Ridderkerk Phone: +31 (0)180 - 46 60 04	Netherlands	SIMPAP s.r.o. Jána Derku 1671 SK-911 01 Trenčín Phone: +421 (0)32 743 04 72	Slovakia						
AutoCont C.S. s.r.o. Technologická 374/6 CZ-708 00 Ostrava-Pustkovec Phone: +420 595 691 150	Czech Republic	Koning & Hartman b.v. Haarlerbergweg 21-23 NL-1101 CH Amsterdam Phone: +31 (0)20 / 587 76 00	Netherlands								
Bejeer Electronics A/S Lykkegårdsvej 17 DK-4000 Roskilde Phone: +45 (0)46 / 75 76 66	Denmark	Bejeer Electronics AS Postboks 487 NO-3002 Drammen Phone: +47 (0)32 / 24 30 00	Norway								
Bejeer Electronics OY Peltola 37 FIN-28400 Ulvila Phone: +358 (0)207 / 463 540	Finland										



Version check

Mitsubishi Electric Europe B.V. / FA - European Business Group / Gothaer Straße 8 / D-40880 Ratingen / Germany / Tel.: +49(0)2102-4860 / Fax: +49(0)2102-4861120 / info@mitsubishi-automation.com / www.mitsubishi-automation.com

Art. no. 251389-B / 11.2012 / Specifications subject to change / All trademarks and copyrights acknowledged.

