



# TRANSISTORIZED INVERTER

-INSTRUCTION MANUAL-

---

RELAY OUTPUT/  
COMPUTER LINK (RS-485)

---

# FR-A5NR

Thank you for choosing the Mitsubishi transistorized inverter option unit.

This instruction manual gives handling information and precautions for use of this equipment. Incorrect handling might cause an unexpected fault. Before using the equipment, please read this manual carefully to use the equipment to its optimum.

Please forward this manual to the end user.

### This section is specifically about safety matters

Do not attempt to install, operate, maintain or inspect this product until you have read through this instruction manual and appended documents carefully and can use the equipment correctly. Do not use this product until you have a full knowledge of the equipment, safety information and instructions.

In this instruction manual, the safety instruction levels are classified into "WARNING" and "CAUTION".



Assumes that incorrect handling may cause hazardous conditions, resulting in death or severe injury.



Assumes that incorrect handling may cause hazardous conditions, resulting in medium or slight injury, or may cause physical damage only.

Note that the CAUTION level may lead to a serious consequence according to conditions. Please follow the instructions of both levels because they are important to personnel safety.

## SAFETY INSTRUCTIONS

### 1. Electric Shock Prevention

#### **WARNING**

- While power is on or when the inverter is running, do not open the front cover. You may get an electric shock.
- Do not run the inverter with the front cover removed. Otherwise, you may access the exposed high-voltage terminals and charging part and get an electric shock.
- If power is off, do not remove the front cover except for wiring or periodic inspection. You may access the charged inverter circuits and get an electric shock.
- Before starting wiring or inspection, switch power off, wait for more than 10 minutes, and check for no residual voltage with a tester or the like.



## WARNING

- Any person who is involved in the wiring or inspection of this equipment should be fully competent to do the work.
- Always install the option unit before wiring. Otherwise, you may get an electric shock or be injured.
- Handle this option unit with dry hands to prevent an electric shock.
- Do not subject the cables to scratches, excessive stress, heavy loads or pinching. Otherwise, you may get an electric shock.

### 2. Injury Prevention



## CAUTION

- Apply only the voltage specified in the instruction manual to each terminal to prevent burst, damage, etc.
- Ensure that the cables are connected to the correct terminals. Otherwise, burst, damage, etc. may occur.
- Always make sure that polarity is correct to prevent burst, damage, etc.
- While power is on or for some time after power-off, do not touch the inverter as it is hot and you may get burnt.

### 3. Additional instructions

Also note the following points to prevent an accidental failure, injury, electric shock, etc.:

#### (1) Transportation and mounting



## CAUTION

- Do not install or operate the option unit if it is damaged or has parts missing.
- Do not stand or rest heavy objects on the product.
- Check that the mounting orientation is correct.
- Prevent screws, metal fragments or other conductive bodies or oil or other flammable substance from entering the inverter.

#### (2) Test operation and adjustment



## CAUTION

- Before starting operation, confirm and adjust the parameters. A failure to do so may cause some machines to make unexpected motions.

### (3) Usage

 <b>WARNING</b>
--

- |                                |
|--------------------------------|
| ● Do not modify the equipment. |
|--------------------------------|

 <b>CAUTION</b>
--

- |  |
|--|
| ● When parameter clear or all parameter clear is performed, each parameter returns to the factory setting. Re-set the required parameters before starting operation. |
| ● For prevention of damage due to static electricity, touch nearby metal before touching this product to eliminate static electricity from your body.                |

### (4) Maintenance, inspection and parts replacement

 <b>CAUTION</b>
--

- |  |
|--|
| ● Do not test the equipment with a megger (measure insulation resistance). |
|--|

### (5) Disposal

 <b>CAUTION</b>
--

- |                              |
|------------------------------|
| ● Treat as industrial waste. |
|------------------------------|

### (6) General instruction

All illustrations given in this manual may have been drawn with covers or safety guards removed to provide in-depth description. Before starting operation of the product, always return the covers and guards into original positions as specified and operate the equipment in accordance with the manual.
--

# CONTENTS

<b>1.PRE-OPERATION INSTRUCTIONS</b>	<b>1</b>
1.1 Unpacking and Product Confirmation .....	1
1.2 Packing Confirmation .....	1
1.3 Structure .....	2
<b>2.INSTALLATION</b>	<b>3</b>
2.1 Pre-Installation Instructions.....	3
2.2 Installation Procedure .....	3
2.3 Wiring.....	5
<b>3.RELAY OUTPUT</b>	<b>6</b>
3.1 Internal Block Diagram.....	6
3.2 Terminals .....	6
<b>4.COMPUTER LINK FUNCTION</b>	<b>7</b>
4.1 Configuration.....	7
4.2 Connection with a Computer.....	9
4.3 Operation Mode .....	10
4.3.1 Operation mode indication .....	10
4.3.2 Operation mode switching .....	11
4.4 Input from computer to inverter .....	16
4.5 Input from inverter to computer .....	17
4.6 Operation mode-based functions.....	20
4.7 Operation .....	21

4.8	Programming of the Computer.....	22
4.9	Adjustment and Setting.....	24
4.10	Instructions.....	35
4.11	Troubleshooting.....	36
4.12	Setting Items and Set Data.....	37
4.13	Error Code List.....	41
4.14	ASCII Code List (Reference).....	42
4.15	Specifications.....	43

# 1. PRE-OPERATION INSTRUCTIONS

## 1.1 Unpacking and Product Confirmation

Take the option unit out of the package, check the unit name, and confirm that the product is as you ordered and intact.

Functions available differ between FR-A500(L)/F500(L) series and FR-V500 series, always check before using.

- SERIAL number check

This product may be used with the FR-A520-0.4K to 55K and FR-A540-0.4K to 22K manufactured in and after November 1997. Any of the models may be used with this unit if its SERIAL number indicated on the rating plate and package has the following version or later.

SERIAL is made up of 1 version symbol and 8 numeric characters indicating year, month, and control number as shown below.

  R      7      Y      ○○○○○○    
Symbol Year Month Control number  
SERIAL number

Inverter	Model	SERIAL Number	Date Manufactured
FREQROL-A500 series	FR-A520-0.4, 0.75K, 11K to 22K	R7Y○○○○○○	in and after November 1997
	FR-A520-1.5 to 7.5K	Q7Y○○○○○○	
	FR-A520-30 to 55K	G7Y○○○○○○	
	FR-A540-0.4 to 22K	G7Y○○○○○○	

## 1.2 Packing Confirmation

Make sure that the package includes the following

- Instruction manual.....1
- Mounting screws M3 × 10 .....2
- Terminal resistor jumpers (Jumpers fitted to the terminal block)...1

## 1.3 Structure

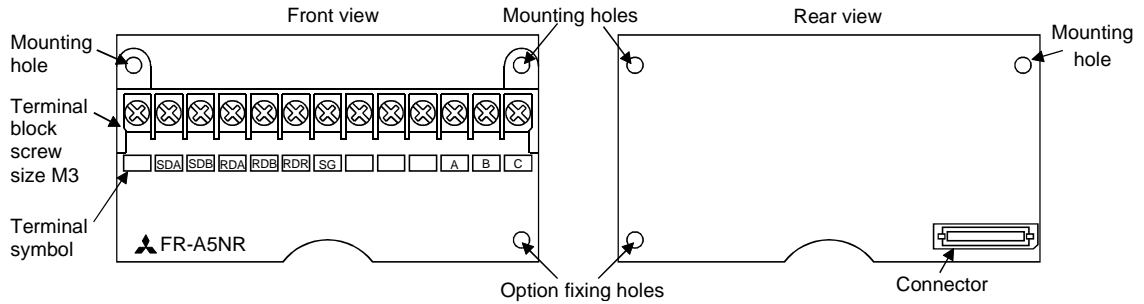



## 2.INSTALLATION

---

### 2.1 Pre-Installation Instructions

---

Make sure that the input power of the inverter is off.



#### **CAUTION**



**With input power on, do not install or remove the option unit. Otherwise, the inverter and option unit may be damaged.**

### 2.2 Installation Procedure

---

- (1) Securely insert the connector of the option unit far into the connector of the inverter. At this time, fit the option fixing holes snugly. For the position of slot, refer to the next page.  
Also be sure to fit the unit into the option fixing hook (For the FR-A500(L)/ FR-F500(L) series, it is available in Aug., 2000).
- (2) Securely fix the option unit to the inverter on both sides with the accessory mounting screws. If the screw holes do not match, the connector may not have been plugged snugly. Check for loose plugging.

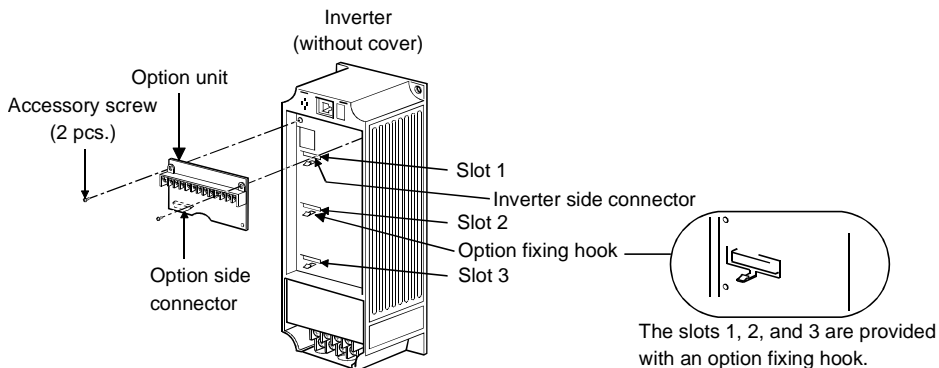

**CAUTION**

1. Only one type of option per inverter may be used. When two or more options are mounted, priority is in order of slots 1, 2 and 3, the options having lower priority are inoperative.
2. When the inverter cannot recognize that the option is mounted, it displays the option error. The errors shown differ according to the mounting slots 1, 2, 3.
3. When one FR- A5NR is used with the other communication option than the FR- A5NR, no error is displayed and the relay output of the FR- A5NR and the communication function of the other communication option are made valid.

Mounting Position	Error Display
Slot 1	E.OP1
Slot 2	E.OP2
Slot 3	E.OP3

### 2.3 Wiring

Route the wires so that they do not take up a lot of space in the control circuit terminal block of the option unit. During wiring, do not leave wire off-cuts in the inverter. They may cause a fault, failure or malfunction. Use the space on the left side of the control circuit terminal unit to route the wires.

Cable routing

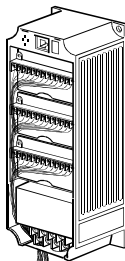



#### REMARKS

The wires with large gauge may not be connected to the terminal block. When connected in parallel, all wires may not fit in the wiring space due to the increased number of wires. In such cases, perform wiring by using a junction terminal block.



#### CAUTION

-  **Do not use empty terminals as junction terminals because they are used in the option unit. If they are used as the junction terminals, the option unit may be damaged.**
-  **When installing the inverter front cover, the cables to the inverter's control circuit terminals and option terminals should be routed properly in the wiring space to prevent them from being caught between the inverter and its cover.**

## 3. RELAY OUTPUT

You can select any of the standard output signals of the inverter and output it as a relay contact signal.

### 3.1 Internal Block Diagram

- (1) To make relay (RA) signal setting, set Pr. 330 "RA output selection". Select the output signal setting from output terminal function selection (Pr. 190 to). For parameter details, refer to the Inverter Instruction Manual.  
Set a positive logic value.

#### CAUTION

**No output signal is given when the Pr. 330 value is "9999" (factory setting).**

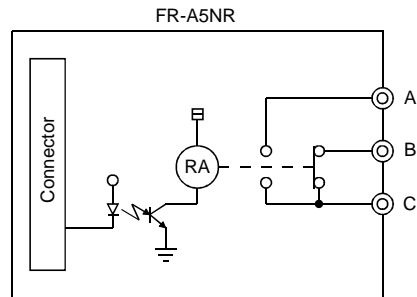

Internal circuit diagram

### 3.2 Terminals

Terminal Symbol	Description
A	Normally open contact terminal of the relay (RA)
B	Normally closed contact terminal of the relay (RA)
C	Contact common terminal of the relay (RA)

\* The operation of the relay depends on the output signal selected.

## 4.COMPUTER LINK FUNCTION

This function allows inverters connected with a computer (such as a personal computer or a factory automation computer) by communication cables to be operated, monitored and their parameters to be transferred by user programs.

### 4.1 Configuration

#### (1) Basic configuration

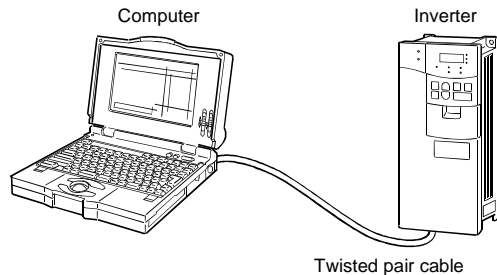

#### (2) System configuration examples

##### 1) Inverters used with a computer having RS-485 or RS-422 interface

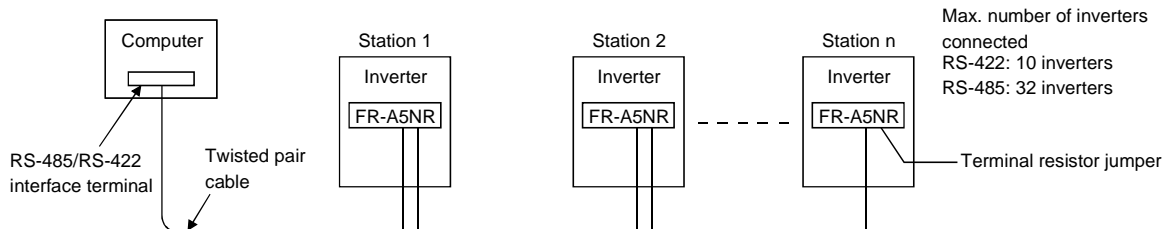

2) Inverters used with a computer having RS-232C interface

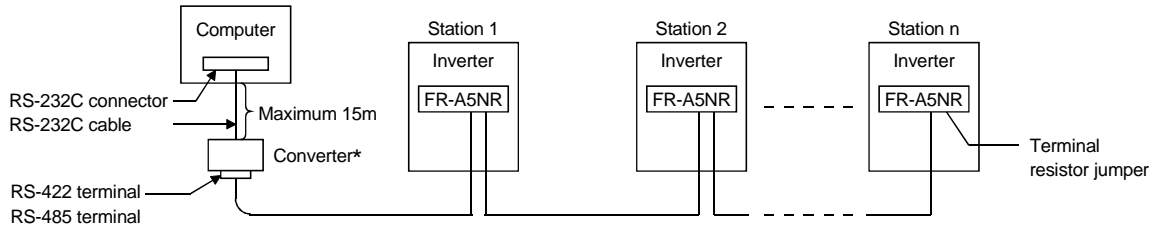

**CAUTION**

**\*Commercially available converter is required.**

**Commercially available converter examples**

**Model: FA-T-RS40**

**Converter**

**Industrial System Division Mitsubishi Electric Engineering Co., Ltd.**

## 4.2 Connection with a Computer

### (1) Connection of one computer and one inverter

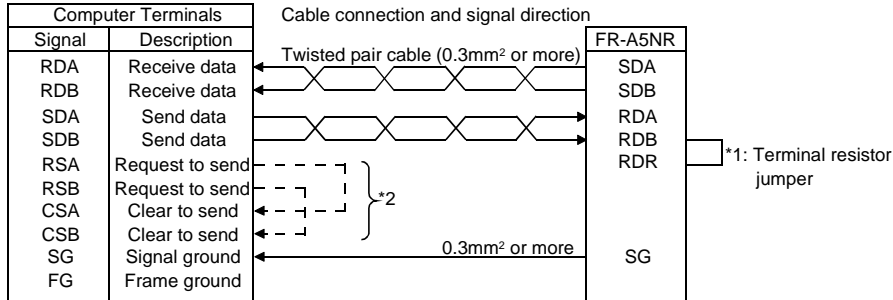

### (2) Connection of one computer and "n" inverters (two or more inverters)

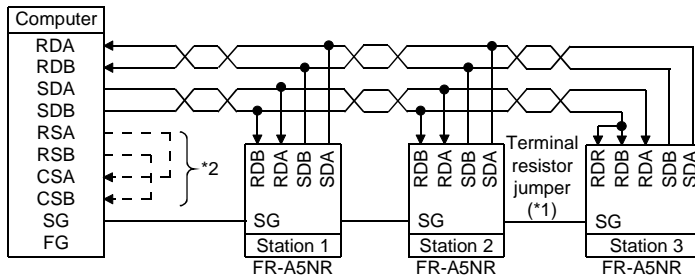

\*1. The terminal resistor jumper should only be connected to the remotest FR-A5NR from the computer.  
(Terminal resistor: 100Ω)

\*2. Connect in accordance with the manual of the computer used.

Note that the computer terminal numbers depend on the model used.

## 4.3 Operation Mode

The inverter mounted with the option unit (FR-A5NR) has the following operation modes:

- (1) PU operation [PU]..... Controls the inverter from the keyboard of the operation panel (FR-DU04(-1)) or parameter unit (FR-PU04(V)) (referred to as the "PU") installed to the inverter.
- (2) External operation [EXT] ..... Controls the inverter by switching on/off external signals connected to the control circuit terminals of the inverter. (The inverter is factory-set to this mode.)
- (3) Network operation [NET] ..... Controls the inverter in accordance with the computer program via the computer link unit (FR-A5NR).  
(The operation signal and running frequency can be entered from the control circuit terminals depends on the Pr. 338 "operation command right" and Pr. 339 "speed command right" setting.)

### 4.3.1 Operation mode indication

FR-DU04(-1)

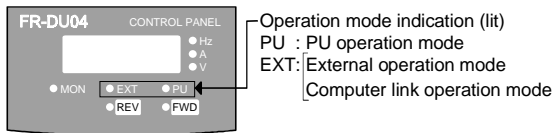

FR-PU04(V)

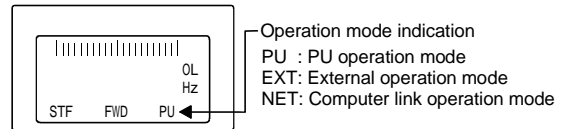



### 4.3.2 Operation mode switching

(1) Operation mode switching conditions

Before switching the operation mode, check that:

- 1) The inverter is at a stop;
- 2) Both the forward and reverse rotation signals are off; and
- 3) The Pr. 79 "operation mode selection" setting is correct.

(For setting, use the inverter's operation panel or optional parameter unit.)

#### REMARKS

The operation mode differs in function between inverters. For details, refer to the Inverter Instruction Manual (Pr. 79 "operation mode selection").

Pr. 79 Setting	Operation Mode Selection	Switching to Network Operation Mode
0	PU or external operation	Disallowed when the PU mode is selected. Allowed when the external mode is selected.
1	PU operation	Disallowed
2	External operation	Allowed
3, 4	External/PU combined operation	Disallowed
5*	Programmed operation	Disallowed (Parameter values write-enabled in the external operation mode may be changed)
6	Switch-over	Allowed
7	External operation (PU operation interlock)	Allowed only in the external operation mode when the PU interlock signal (X12) is on.
8	PU or external (signal switching)	Allowed only in the external operation mode (X16 on).

\* Programmed operation is available only with the FR-A500(L) series.

(2) Operation mode switching method

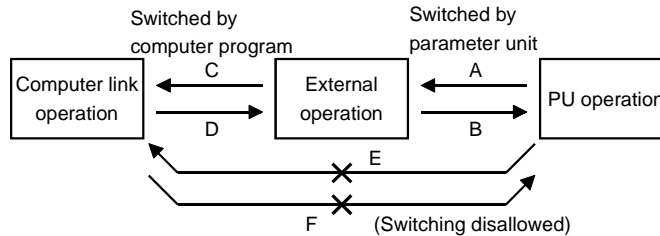

Symbol	Switching Type	Switching Method
A	PU operation → External operation	Operate the external operation key sheet on the PU.
B	External operation → PU operation	Operate the PU operation key sheet on the PU.
C	External operation → Computer link operation	By the user program of the computer (refer to page 22).
D	Computer link operation → External operation	By the user program of the computer (refer to page 22).
E	PU operation → Computer link operation	Switching disallowed. Allowed if external operation is selected in A and computer link operation is then selected in C. **
F	Computer link operation → PU operation	Switching disallowed. Allowed if external operation is selected in D and PU operation is then selected in B. **

\* When "1" or "2" is set in Pr. 340 "link startup mode selection", the operation mode is computer link operation at power on or inverter reset.

**CAUTION**

1. When setting "1" or "2" in Pr. 340, the initial settings (station number setting, etc.) of the inverter must be made without fail. Refer to page 24 for the parameter details.
2. \*\*: In the switch-over mode (Pr. 79 = 6), switching in E and F is allowed.

## COMPUTER LINK FUNCTION

### (3) Link startup mode selection (Pr. 340)

The operation mode at power on and at restoration from instantaneous power failure can be selected.

To choose the Computer link operation mode, set "1" or "2" in Pr. 340.

The Pr. 340 "link startup mode selection" value may be changed in any operation mode.

Pr. 340 Setting	Operation Mode		Mode at Power On or at Restoration from Instantaneous Power Failure
	Pr. 79		
0 (Factory Setting)	0	PU or external operation	Inverter operates in the external operation mode.
	1	PU operation	Inverter operates in the PU operation mode.
	2	External operation	Inverter operates in the external operation mode.
	3	External/PU combined operation	Operation command is set in the PU operation mode and the start signal is set in the external operation mode.
	4	External/PU combined operation	Operation command is set in the external operation mode and the start signal is set in the PU operation mode.
	5*	Programmed operation	Inverter operates in the programmed operation mode.
	6	Switch-over	Inverter operates in the external operation mode. Operation mode is switched while running.
	7	PU operation interlock	X12 signal ON..... Inverter operates in the external operation mode. (Operation mode can be switched to the PU operation mode from the parameter unit.) X12 signal OFF ..... Inverter operates in the external operation mode.
	8	Operation mode switch-over by the external signal	X16 signal ON..... Inverter operates in the external operation mode. X16 signal OFF ..... Inverter operates in the PU operation mode.

\* Programmed operation is available only with the FR-A500(L) series.

Pr. 340 Setting	Operation Mode		Mode at Power On or at Restoration from Instantaneous Power Failure
	Pr. 79		
1, 2	0	PU or external operation	Inverter operates in the computer link operation mode. (Program need not be used for switching)
	1	PU operation	Inverter operates in the PU operation mode.
	2	External operation	Inverter operates in the computer link operation mode. (Program need not be used for switching.)
	3	External/PU combined operation	Operation command is set in the PU operation mode and the start command is set in the external operation mode.
	4	External/PU combined operation	Operation command is set in the external operation mode and the start command is set in the PU operation mode.
	5*	Programmed operation	Inverter operates in the programmed operation mode.
	6	Switch-over	Inverter operates in the computer link operation mode. Operation mode is switched while running. Refer to the inverter manual for details.
	7	PU operation interlock	X12 signal ON..... Inverter operates in the computer link operation mode. (Operation mode can be switched to the external operation mode by the program.) X12 signal OFF ..... Inverter operates in the external operation mode.
8	Operation mode switch-over by the external signal	X16 signal ON..... Inverter operates in the computer link operation mode. (Operation mode can be switched to the external operation mode by the program.) X16 signal OFF ..... Inverter operates in the PU operation mode.	

\* Programmed operation is available only with the FR-A500(L) series.

**CAUTION**

---

---

**Computer programming, which has stopped due to an instantaneous power failure or like during computer link operation, remains stopped even if power is recovered.**

---

---



**CAUTION**



**If an instantaneous power failure occurs with "2" set in Pr. 340 "link startup mode selection", the inverter continues operation in the status prior to the instantaneous power failure. (When Pr. 57≠"9999")**

## 4.4 Input from computer to inverter

### (1) Operation commands

The following commands can be given:

bit	FREQROL-A500(L)/FR-F500(L) Series		FREQROL-V500 Series	
	Terminal name	Operation command (Signal name)	Terminal name	Operation command (Signal name)
0	AU	Current input selection(AU)*	-	-
1	STF	Forward rotation(STF)	STF	Forward rotation(STF)
2	STR	Reverse rotation(STR)	STR	Reverse rotation(STR)*
3	RL	Low speed(RL)*	DI1	Low speed(RL)*
4	RM	Middle speed(RM)*	DI2	Middle speed(RM)*
5	RH	High speed(RH)*	DI3	High speed(RH)*
6	RT	Second acceleration/ deceleration(RT)*	DI4	Second acceleration/ deceleration(RT)*
7	MRS	Output halt(MRS)	-	-

The terminal signals marked \* are factory-setting. They can be changed using input terminal function selection (Pr. 180 to). Input terminal function selection differ in function between inverters. For details, refer to the Inverter Instruction Manual.

### (2) Output frequency (Running speed)

Within the output range, the output frequency can be set for the FR-A500(L)/F500(L) series, and the running speed for the FR-V500 series.

#### REMARKS

- For the FR-A500(L)/F500(L) series, operation speed setting can be made by using Pr. 37 "speed display".
- For the FR-V500 series, the operation speed can be set in 0.1r/min increments when command code FF=1.
- The setting range of the set frequency differs according to inverters. Refer to the Inverter Instruction Manual for details.

### (3) Inverter reset

The inverter can be reset from the computer.

**(4) Parameter setting write**

For the parameters indicated in the "data code list" of the Inverter Instruction Manual, their settings can be written.

**4.5 Input from inverter to computer****(1) Inverter status**

The following operating status can be monitored.

bit	FREQROL-A500(L)/FR-F500(L) Series		FREQROL-V500 Series	
	Terminal symbol	Operation command (Signal name)	Terminal symbol	Operation command (Signal name)
0	RUN	Running(RUN)*	—	Running(RUN)
1	—	Forward running	—	Forward running
2	—	Reverse running	—	Reverse running
3	SU	Up to frequency(SU)*	DO1	Running(RUN)*
4	OL	Overload(OL)*	DO2	Up to speed(SU)*
5	IPF	Instantaneous power failure(IPF)*	DO3	Instantaneous power failure(IPF)*
6	FU	Frequency detection(FU)*	—	Speed detection(FU)
7	ABC	Alarm occurrence(ABC)*	ABC	Alarm occurrence(ABC)*

The terminal signals marked \* are factory-setting. The output signals can be changed using output terminal function selection (Pr. 190 to). Output terminal function selection differ in function between inverters. For details, refer to the Inverter Instruction Manual.

**(2) Inverter monitoring**

- Output frequency (speed).. Binary in 0.01Hz (1r/min) increments (FR-A500/F500 series)  
Running speed..... Binary in 1r/min [FF=0], 0.1r/min [FF=1] increments
- Output current..... Binary in 0.1A increments
- Output voltage ..... Binary in 0.1V increments
- Special monitor ..... For details, refer to the Inverter Instruction Manual.
- Alarm definition..... Binary (up to eight most recent alarms)

- (3) Parameter setting read  
For the parameters indicated in the "data code list" of the Inverter Instruction Manual, their settings can be read.
- (4) Operation at alarm occurrence

Alarm Occurrence	Status		Operation Mode		
			PU operation	External operation	Computer link operation (when FR-A5NR is used)
Inverter fault	Inverter operation		Stop	Stop	Stop
	Data communication	PU connector	Continued	Continued	Continued
		FR-A5NR	Continued	Continued	Continued
Communication error (communication from PU connector)	Inverter operation		Stop/continued (*1)	Continued	Continued
	Data communication	PU connector	Stop	Stop	Stop
		FR-A5NR	Continued	Continued	Continued
Communication error (inboard option)	Inverter operation		Continued	Continued	Stop/continued (*2)
	Data communication	PU connector	Continued	Continued	Continued
		FR-A5NR	Stop	Stop	Stop

\*1. Can be selected by parameter setting (factory-set to continued).

\*2. Can be selected by parameter setting (factory-set to stop).



## **COMPUTER LINK FUNCTION**

### (5) Communication error

<b>Error Occurrence</b>	<b>Error Code</b>
Communication error (communication from PU connector)	E.PUE
Communication error (FR-A5NR)	E.OP1 to E.OP3

### (6) Inverter reset

<b>Resetting Method</b>	<b>Operation Mode</b>		
	<b>Computer link operation</b>	<b>External operation</b>	<b>PU operation</b>
Computer user program	Allowed (CAUTION)	Disallowed	Disallowed
Terminals RES-SD ON	Allowed	Allowed	Allowed
Inverter power OFF	Allowed	Allowed	Allowed

### **CAUTION**

**When the inverter is reset in the computer link operation mode, it is put in the external operation mode. Accordingly, to resume computer link operation, switch the operation mode to computer link operation again.**

## 4.6 Operation mode-based functions

### (1) Operation mode-based functions

Control Location	Item	Operation Mode		
		PU operation	External operation	Computer link operation (when FR-A5NR is used)
Computer user program via PU connector	Operation command (start)	Allowed	Disallowed	Disallowed
	Running frequency setting (*1)	Allowed	Allowed (combined operation mode)	Disallowed
	Monitoring	Allowed	Allowed	Allowed
	Parameter write	Allowed (*5)	Disallowed (*5)	Disallowed (*5)
	Parameter read	Allowed	Allowed	Allowed
	Inverter reset (*3)	Allowed	Allowed	Allowed
	Stop command (*4)	Allowed	Allowed	Allowed
Computer user program via FR-A5NR	Operation command	Disallowed	Disallowed	Allowed
	Running frequency setting(*1)	Disallowed	Disallowed	Allowed (*2)
	Monitoring	Allowed	Allowed	Allowed
	Parameter write	Disallowed (*5)	Disallowed (*5)	Allowed (*5)
	Parameter read	Allowed	Allowed	Allowed
	Inverter reset (*3)	Disallowed	Disallowed	Allowed
	Stop command (*4)	Disallowed	Disallowed	Allowed
Control circuit terminal	Inverter reset	Allowed	Allowed	Allowed
	Operation command	Disallowed	Allowed	Allowed (*2)
	Running frequency setting (*1)	Disallowed	Allowed	Allowed (*2)

\*1. "Running speed setting" for the FR-V500 series.

\*2. Depends on the Pr. 338 "operation command right" and Pr. 399 "speed command right" settings.

\*3. Cannot be reset from the computer when an RS-485 communication error occurs.

\*4. Depends on the Pr. 75 "reset selection" setting.

\*5. Depends on the Pr. 77 "parameter write inhibit selection" setting.

## 4.7 Operation

- (1) General operation
  - 1) The computer CPU decodes and executes the user program.
  - 2) Communication data in accordance with the user program is converted into serial signals in the computer and is then converted at the interface level conforming to the RS-422 or RS-485 standard, then transmitted to the inverter by the driver.
  - 3) The communication data is received by the receiver in the FR-A5NR unit, converted into parallel signals by the communication LSI, and transmitted to the inverter CPU.
  - 4) The inverter CPU checks the data for errors, processes the data in accordance with the check result, and creates reply data.
  - 5) The reply data is converted into serial signals by the communication LSI in the FR-A5NR unit and is then converted at the interface level conforming to the RS-422 or RS-485 standard, then returned to the computer.
  - 6) The reply data is received by the receiver in the computer, read and checked in accordance with the user program.
- (2) Function block diagram

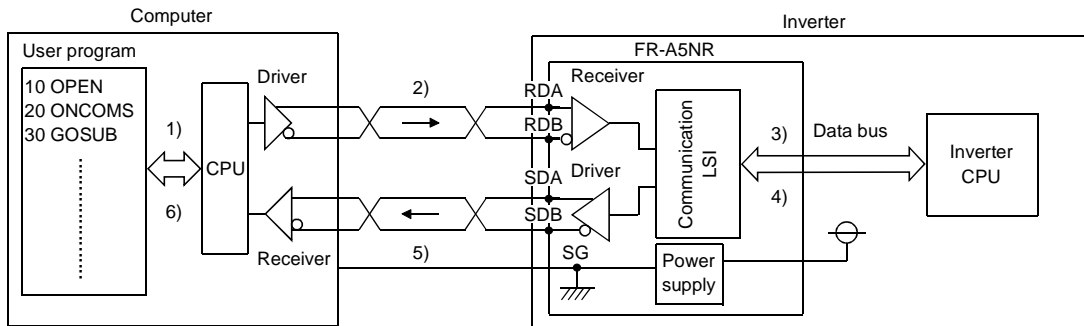

## 4.8 Programming of the Computer

- (1) For full information on the communication protocols, whether communication operation is performed or not, data format types, data formats, and data explanations, refer to the "Pr. 117 to Pr. 124" sections of the inverter manual.
- (2) Program example

When the operation mode is switched to computer link operation.

### Program

Line number		Initial setting of I/O file
10	OPEN"COM1:9600,E,8,2,HD"AS #1	: Communication file opening
20	COMST1,1,1:COMST1,2,1	: Circuit control signal (RS, ER) ON/OFF setting
30	ON COM(1)GOSUB*REC	: Interrupt definition at data receive
40	COM(1)ON	: Interrupt enable
50	D\$="01FB10000"	Transmission data setting
60	S=0	
70	FOR I=1 TO LEN(D\$)	
80	A\$=MID\$(D\$,I,1)	
90	A=ASC(A\$)	Sum code calculation
100	S=S+A	
110	NEXT I	
120	D\$=CHR\$(&H5)+D\$+RIGHT\$(HEX\$(S),2)	: Addition of control and sum codes
130	PRINT#1,D\$	Data transmission
140	GOTO 50	
1000	*REC	
1010	IF LOC(1)=0 THEN RETURN	Interrupt data receive
1020	PRINT"RECEIVE DATA"	: Interrupt occurrence at data receive
1030	PRINT INPUT\$(LOC(1),#1)	
1040	RETURN	

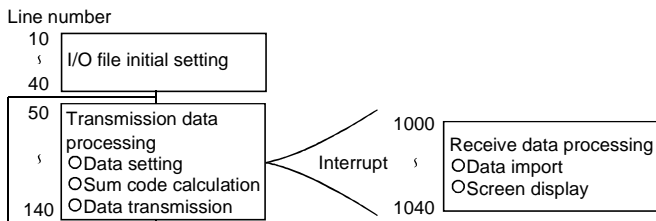

### Programming instructions

- 1) The inverter does not accept data from the computer if it has an error. For this reason, a retry program for data error must be included in the user program.
- 2) A request of any data communication, e.g. operation command, monitoring, is always given by the computer and the inverter will return data to the computer. Hence, the program should be written to give a data read request as required from the computer at the time of monitoring, etc.

### ⚠ CAUTION

- ⚠ **When the inverter's communication check time interval is not set, switching to computer link operation causes any of "E.OP1 to E.OP3" to occur. Always set the communication check time interval before starting operation.**
- ⚠ **Data communication is not started automatically but is made only once when the computer provides a communication request. If communication is disabled during operation due to signal cable breakage etc., the inverter cannot be stopped. When the communication check time interval has elapsed, the inverter will come to an alarm stop (E.OP1 to E.OP3). (Pr. 336≠9999) The inverter can be coasted to a stop by switching on its RES signal or by switching power off.**
- ⚠ **If communication is broken due to signal cable breakage, computer fault etc., the inverter does not detect such a fault. This should be fully noted.**

## 4.9 Adjustment and Setting

### Parameters

Fitting this option unit adds the following parameters.

Parameter Number	Name	Setting Range	Setting Increments	Factory Setting	Refer to
331	Inverter station number	0 to 31	1	0	24
332	Communication speed	3, 6, 12, 24, 48, 96, 192	1	96	25
333	Stop bit length/data length	0, 1 (data length 8) 10, 11 (data length 7)	1	1	25
334	Parity check presence/absence	0, 1, 2	1	2	25
335	Number of communication retries	0 to 10, 9999	1	1	26
336*	Communication check time interval	0 to 999.8 s, 9999	0.1	0	27
337	Waiting time setting	0 to 150ms, 9999	1ms	9999	27
338	Operation command write	0, 1	1	0	28
339	Speed command write	0, 1	1	0	28
340	Link startup mode selection	0, 1, 2	1	0	13
341	CR, LF presence/absence selection	0, 1, 2	1	1	25
342	E <sup>2</sup> PROM write yes/no	0, 1	1	0	34

\* To make communication, set a value other than 0 in Pr. 336 "communication check time interval".

(1) Station number setting (Pr. 331 "inverter station number")

1) The station number may be set between 0 and 31.

When the RS-422 interface is used, the station number may be set between 0 and 31 but the number of inverters connected must be 10 or less.

2) Note that the same station number cannot be set for different inverters. (If such setting has been made, proper communication cannot be performed.)

## COMPUTER LINK FUNCTION

3) Station numbers do not have to be sequential and may be skipped, e.g. as shown below:

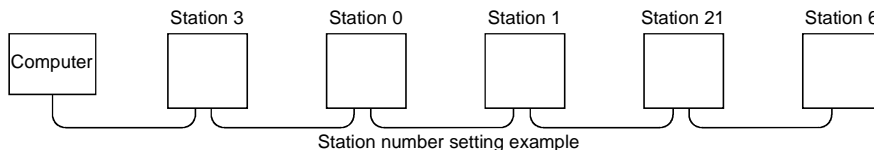

(2) Communication specifications

Refer to the following table and set the parameters: (★: Factory setting)

Parameter Number	Description	Instruction Code	Data Setting	Definition
332	Communication speed	H20: Read HA0: Write (When HFF=3)	3, 6, 12, 24, 48, 96★, 192	3: 300bps, 6: 600bps, 12: 1200bps, 24: 2400bps, 48: 4800bps, 96: 9600bps, 192: 19200bps
333	Stop bit length/ data length	H21: Read HA1: Write (When HFF=3)	0, 1★, 10, 11	0, 10: Stop bit length = 1 bit 1, 11: Stop bit length = 2 bits 0, 1: Data length = 8 bits 10, 11: Data length = 7 bits
334	Parity check presence/absence	H22: Read HA2: Write (When HFF=3)	0, 1, 2★	0: No parity check 1: Odd parity 2: Even parity
341	CR, LF instruction presence/absence	H29: Read HA9: Write (When HFF=3)	0, 1★, 2	0: Without CR and LF 1: With CR only 2: With CR and LF

### CAUTION

The inverter communication will not error if the Pr. 333 "stop bit length" setting differs from the actual data value.

(3) Number of data communication error retries

Set the permissible number of retries at occurrence of data receive error. If the number of consecutive errors exceeds the permissible value, the inverter will come to an alarm stop.

Parameter Number	Name	Instruction Code	Data Setting	Definition
335	Number of communication retries	H23: Read HA3: Write (When HFF=3)	0 to 10	Permissible number of retries at error occurrence (If the number of retries exceeds the preset value, the inverter will come to an alarm stop. (Factory-set to 1))
			9999 (65535)	If a communication error occurs, the inverter will not come to an alarm stop. At this time, the inverter can be coasted to a stop by MRS or RES input. During an error, the minor fault signal (LF) is given to the open collector output. Allocate the terminal used with any of Pr. 190 to Pr. 195 (output terminal function selection).



## COMPUTER LINK FUNCTION

### (4) Permissible communication time interval

Set the permissible communication time interval between the computer and inverter.

(If no-communication with the computer persists for more than the permissible time, the inverter will come to an alarm stop due to time-out error.)

Parameter Number	Name	Instruction Code	Data Setting	Definition
336	Communication check time interval	H24: Read HA4: Write (When HFF=3)	0.1 to 999.8	Permissible communication time interval (0.1 s. increments)
			(9999) 65535*	Communication check stop
			0 (factory setting)	Computer link operation disallowed

\* The data to be entered from the parameter unit is 9999 and that from the computer is 65535 (HFFFF).

### REMARKS

1. At power-on (or reset), communication time interval check begins when the first communication is made in the computer link operation mode.
2. If the parameter setting is changed, checking begins after parameter values are written.

### CAUTION

 **If communication is broken due to signal cable breakage, computer fault etc., the inverter does not detect such a fault. This should be fully noted.**

### (5) Waiting time setting

Determines the waiting time till the reply data is transmitted.

Parameter Number	Name	Instruction Code	Data Setting	Definition
337	Waiting time setting	H25: Read HA5: Write (When HFF=3)	0 to 150	Set the waiting time between data transmission to the inverter and response.
			9999	Set with communication data.

(6) Control location selection

In the computer link operation mode, operation can be performed by signals from external terminals in accordance with the settings of Pr. 338 "operation command write" and Pr. 339 "speed command write".

●FR-A500(L)/F500(L) series

Control location selection	Operation command write (Pr. 338)		0: Computer	0: Computer	1: External	1: External	Remarks
	Speed command write (Pr. 339)		0: Computer	1: External	0: Computer	1: External	
Fixed functions (Functions equivalent to terminals)	Forward rotation command (STF)		Computer	Computer	External	External	
	Reverse rotation command (STR)		Computer	Computer	External	External	
	Start self-holding selection (STOP)		—	—	External	External	
	Output halt (MRS)		Both	Both	External	External	(Note 1, 4)
	Reset (RES)		Both	Both	Both	Both	
	Computer link operation frequency		Computer	—	Computer	—	
	2		—	External	—	External	
	4		—	External	—	External	
1		Compensation	External	Compensation	External		
Selective functions Pr. 180 to Pr. 186 settings (Caution 2)	0	Low-speed operation command (RL)	Computer	External	Computer	External	Pr. 59 = 0
	1	Middle-speed operation command (RM)	Computer	External	Computer	External	Pr. 59 = 0
	2	High-speed operation command (RH)	Computer	External	Computer	External	Pr. 59 = 0
	3	Second function selection (RT)	Computer	Computer	External	External	
	4	Current input selection (AU)	—	External	—	Both	
	5	Jog operation selection (JOG)	—	—	External	External	
	6	Automatic restart after instantaneous power failure selection (CS)	External	External	External	External	

## COMPUTER LINK FUNCTION

### ●FR-A500(L)/F500(L) series

Control location selection	Operation command write (Pr. 338)		0: Computer	0: Computer	1: External	1: External	Remarks
	Speed command write (Pr. 339)		0: Computer	1: External	0: Computer	1: External	
Selective functions Pr. 180 to Pr. 186 settings (Caution 2)	7	External thermal relay input (OH)	External	External	External	External	
	8	15-speed selection (REX)	Computer	External	Computer	External	Pr. 59 = 0
	9	Third function (X9)	Computer	Computer	External	External	
	10	FR-HC connection, inverter operation enable (X10)	External	External	External	External	
	11	FR-HC connection, instantaneous power failure detection (X11)	External	External	External	External	
	12	PU operation external interlock (X12)	External	External	External	External	
	13	External DC dynamic braking start (X13)	Computer	Computer	External	External	
	14	PID control valid terminal (X14)	Computer	External	Computer	External	
	15	Brake opening completion signal (BRI)	Computer	Computer	External	External	
	16	PU operation-external operation switching (X16)	External	External	External	External	
	17	Load pattern selection-forward/reverse rotation boost switching (X17)	Computer	Computer	External	External	
	18	Magnetic flux-V/F switching (X18)	Computer	Computer	External	External	
	19	Load torque high-speed frequency (X19)	Computer	Computer	External	External	
	20	S-pattern acceleration/deceleration C switching terminal (X20)	Computer	Computer	External	External	
22	Orientation command(X22)	Computer	Computer	External	External	(Caution 3)	
23	Pre-excitation (LX)	Computer	Computer	External	External		

●FR-A500(L)/F500(L) series

Control location selection	Operation command write (Pr. 338)	0: Computer	0: Computer	1: External	1: External	Remarks
	Speed command write (Pr. 339)	0: Computer	1: External	0: Computer	1: External	
RH, RM, RL, RT selection functions	Remote setting (RH, RM, RL)	Computer	External	Computer	External	Pr. 59 = "1, 2"
	Programmed operation group selection (RH, RM, RL)	—	—	—	—	Pr. 79 = "5" Computer link operation disallowed
	Stop-on-contact selection 0 (RL)	Computer	External	Computer	External	Pr. 270 =
	Stop-on-contact selection 1 (RT)	Computer	Computer	External	External	"1, 3"

**[Explanation of table]**

- External : Only control by signal from external terminal is valid.
- Computer : Only control from sequence program is valid.
- Both : Only control from both external terminal and computer is valid.
- : Control from both external terminal and computer is invalid.
- Compensation : Control by signal from external terminal is valid if Pr. 28(multi-speed input compensation) setting is "1".

**CAUTION**

1. If the FR-HC is connected, if the inverter operation enable signal (X10) is not assigned when the FR-HC is used (Pr. 30 = "2") or if the PU operation interlock signal (X12) is not assigned when the PU operation interlock function is set (Pr. 79 = "7"), this function is also used by the MRS signal and therefore the MRS signal is only valid for the external terminals, independently of the Pr. 338 and Pr.339 settings.
2. Pr. 180 to Pr. 186 (input terminal function selection) differ in function between inverters. For details, refer to the Inverter Instruction Manual.
3. The orientation command requires the FR-A5AP and FR-A5AX options.
4. When the MRS signal is assigned for both Computer and External, the output halt command is as indicated in the following table.

Computer	External	Output Halt Command	
		Pr.17="0"	Pr.17="2"
ON	ON	Output stopped	Output not stopped
ON	OFF	Output stopped	Output stopped
OFF	ON	Output stopped	Output stopped
OFF	OFF	Output not stopped	Output stopped

● FR-V500 series

Control location selection	Operation command write (Pr. 338)		0: Computer	0: Computer	1: External	1: External	Remarks	
	Speed command write (Pr. 339)		0: Computer	1: External	0: Computer	1: External		
Fixed functions (Functions equivalent to terminals)	Forward rotation command, (STF)		Computer	Computer	External	External		
	Reverse rotation command (STR)		Computer	Computer	External	External		
	Reset (RES)		Both	Both	Both	Both		
	External thermal relay (OH)		External	External	External	External		
	Computer link operation speed		Computer	—	Computer	—		
	2		—	External	—	External		
	1		Compensation	External	Compensation	External		
	3		—	External	—	External		
6		—	External	—	External			
Selective functions	Pr. 180 to Pr. 187 (Caution 2) settings	0	Low-speed operation command, Remote setting (setting clear) (RL)	Computer	External	Computer	External	Pr. 59≠"0": Remote setting
		1	Middle-speed operation command, Remote setting (deceleration) (RM)	Computer	External	Computer	External	
		2	High-speed operation command, Remote setting (acceleration) (RH)	Computer	External	Computer	External	
		3	Second function selection (RT)	Computer	Computer	External	External	
		5	Jog operation selection (JOG)	—	—	External	External	
		8	15-speed selection (REX)	Computer	External	Computer	External	
		9	Third function (X9)	Computer	Computer	External	External	
		10	FR-HC connection, FR-CV connection (inverter operation enable) (X10)	External	External	External	External	
11	FR-HC connection, instantaneous power failure detection (X11)	External	External	External	External			

## COMPUTER LINK FUNCTION

### ● FR-V500 series

Control location selection	Operation command write (Pr. 338)		0: Computer	0: Computer	1: External	1: External	Remarks
	Speed command write (Pr. 339)		0: Computer	1: External	0: Computer	1: External	
Selective functions Pr. 180 to Pr. 187 settings (Caution 2)	12	PU operation external interlock (X12)	External	External	External	External	
	14	PID control enable terminal (X14)	Computer	External	Computer	External	
	15	Brake sequence opening completion signal (BRI)	Computer	Computer	External	External	
	16	PU-external operation switchover (X16)	External	External	External	External	
	20	S-pattern acceleration/deceleration C switchover (X20)	Computer	Computer	External	External	
	22	Orientation command(X22)	Computer	Computer	External	External	
	23	Pre-excitation/servo ON (LX)	Computer	Computer	External	External	
	24	Output stop (MRS)	Both	Both	External	External	(Caution 2)
	25	Start self-holding selection (STOP)	—	—	External	External	
	26	Control mode changing (MC)	Computer	Computer	External	External	
	27	Torque restriction selection (TL)	Computer	Computer	External	External	
	42	Torque bias selection 1 (X42)	Computer	Computer	External	External	
	43	Torque bias selection 2 (X43)	Computer	Computer	External	External	
44	P control selection (P/PI control switchover) (X44)	Computer	Computer	External	External		

[Explanation of table]

External : Only control by signal from external terminal is valid.

Computer : Only control from sequence program is valid.

Both : Only control from both external terminal and computer is valid.

— : Control from both external terminal and computer is invalid.

Compensation : Control by signal from external terminal is valid if Pr. 28 (multi-speed input compensation) setting is "1".

**CAUTION**

- For details of Pr. 180 to Pr. 183, Pr. 187 (input terminal function selection), refer to the Inverter Instruction Manual.
- When the MRS signal is assigned for both Computer and External, the output halt command is as indicated in the following table.

Computer	External	Output Halt Command	
		Pr.17="0"	Pr.17="2"
ON	ON	Output stopped	Output not stopped
ON	OFF	Output stopped	Output stopped
OFF	ON	Output stopped	Output stopped
OFF	OFF	Output not stopped	Output stopped

- (7) E<sup>2</sup>PROM write yes/no (Pr. 342 "E<sup>2</sup>PROM write yes/no")

Select the write destination of parameter write to be performed from the computer.

The setting of Pr. 342 "E<sup>2</sup>PROM write yes/no" is valid for only computer link communication operation.

Parameter Number	Name	Instruction Code	Data Setting	Description
342	E <sup>2</sup> PROM write yes/no	H2A: Read HAA: Write (When HFF=3)	0	Parameters are written to the E <sup>2</sup> PROM when parameter write is performed from the computer.
			1	Parameters are written to the RAM when parameter write is performed from the computer.

When write to RAM is set, new parameter settings are cleared at power-off of the inverter. Therefore, when the inverter is powered on again, the parameter settings are the values stored into the E<sup>2</sup>PROM previously. When changing the parameter values frequently, set "1" in Pr. 342 to write them to the RAM.



## 4.10 Instructions



### (1) Programming instructions

- 1) The inverter does not accept data from the computer if it has an error. For this reason, a retry program for data error must be included in the user program.
- 2) A request for any data communication, e.g. operation command, monitoring, is always given by the computer and the inverter will return data to the computer. Hence, the program should be written to give a data read request as required from the computer at the time of monitoring, etc.
- 3) Data for link parameter expansion setting differs as indicated below depending on the parameter number (For details, refer to the Inverter Instruction Manual.):

		Instruction Code	Data
Link parameter expansion setting	Read	H7F	(Example: F-A500 series) H00:Pr.0 to Pr.96 H01:Pr.100 to Pr.158, Pr.900 to Pr.905
	Write	HFF	H02:Pr.160 to Pr.287 H09:Pr.990

### (2) Operating instructions

#### CAUTION

-  **To prevent hazard conditions, the inverter is designed to be inoperative when the inverter's permissible communication time interval is not set. Therefore, always set the permissible communication time interval before starting operation.**
-  **Data communication is not started automatically but is made only once when the computer provides a communication request. If communication is disabled during operation due to signal cable breakage etc., the inverter cannot be stopped. When the permissible communication time interval has elapsed, the inverter will come to an alarm stop (E.OP1 to E.OP3). The inverter can be coasted to a stop by shorting the inverter terminals RES-SD or by switching power off.**

## 4.11 Troubleshooting

---

- (1) Data from computer is not recognised by the inverter.
  - 1) Does the computer communication protocol conform to the RS-422 or RS-485 standard?
  - 2) Are the FR-A5NR unit and communication cables fitted correctly? (Check for contact fault, open cable, wrong polarity, etc.)
  - 3) Inverter initialization correct?
  - 4) Is the station number setting (Pr. 331) correct? (Check that inverter station setting and user program matches and that the same station number is not used for different inverters.)
  - 5) Is the correct communication request program being executed in the computer?
- (2) Inverter does not switch to computer link operation
  - 1) Is the inverter in external operation mode? Are signals to external terminals STF or STR off?
  - 2) Is the correct operation mode switching program executed?
- (3) Inverter does not start in computer link mode
  - 1) Inverter starting program executed properly?
  - 2) Is the control location selection condition (page 28) set correctly?
  - 3) Inverter output provided?
  - 4) Is the permissible communication time interval set correctly?
- (4) The inverter is brought to alarm stop during operation due to a communication fault
  - 1) Are the FR-A5NR unit and communication cables fitted properly? (Check for contact fault, open cable, etc.)
  - 2) Is the computer operating correctly?
  - 3) Has the program been written to give communication request from computer periodically?
  - 4) Is the format of the data transferred correct?
  - 5) Is the terminal resistor jumper connected correctly?

## 4.12 Setting Items and Set Data

After completion of parameter setting, setting the instruction codes and data and starting communication from the computer enables various types of operation control and monitoring.

This section gives only the information different from that of computer link operation (RS-485 communication) performed from the PU connector of the inverter fitted with the FR-A5NR. For items not given here, refer to the Inverter Instruction Manual (Pr. 117 to Pr. 124).

- FR-A500(L)/F500(L) series

No.	Item	Instruction Code	Description																
1	Operation mode	Read	H0000: Computer link operation H0001: External operation H0002: PU operation																
		Write	H0000: Computer link operation H0001: External operation H0002: PU operation (Setting is enabled only during switch over mode (Pr.79="6").)																
3	Run command	HFA	<p>H00 to HFF: Run command</p> <p>b15                      b7                      b0</p> <table border="1" style="margin-left: 20px;"> <tr> <td>0</td><td>0</td><td>0</td><td>0</td><td>0</td><td>0</td><td>0</td><td>0</td><td>0</td><td>0</td><td>0</td><td>0</td><td>0</td><td>0</td><td>1</td><td>0</td> </tr> </table> <p>(For example 1) [Example 1] H02.....Forward rotation</p> <p>[Example 2] H00.....Stop</p> <p>b0: Current input selection (AU)* b1: Forward rotation (STF) b2: Reverse rotation (STR) b3: Low speed (RL)* b4: Middle speed (RM)* b5: High speed (RH)* b6: Second function selection (RT)* b7: Output halt (MRS)</p> <p>The input signals marked * change with the settings of Pr. 180 to Pr. 186 (input terminal function selection). For details, refer to the Inverter Instruction Manual.</p>	0	0	0	0	0	0	0	0	0	0	0	0	0	0	1	0
0	0	0	0	0	0	0	0	0	0	0	0	0	0	1	0				

No.	Item	Instruction Code	Description								
4	Inverter status monitor	H7A	<p>H00 to HFF: Inverter status monitor</p> <div style="display: flex; align-items: center; justify-content: center;"> <div style="margin-right: 20px;"> <p style="margin: 0;">b7                      b0</p> <table border="1" style="border-collapse: collapse; text-align: center;"> <tr> <td style="padding: 2px 5px;">0</td> <td style="padding: 2px 5px;">0</td> <td style="padding: 2px 5px;">0</td> <td style="padding: 2px 5px;">0</td> <td style="padding: 2px 5px;">0</td> <td style="padding: 2px 5px;">0</td> <td style="padding: 2px 5px;">1</td> <td style="padding: 2px 5px;">0</td> </tr> </table> </div> <div> <p style="margin: 0;">b0: Inverter running (RUN)*  b1: Forward running (STF)  b2: Reverse running (STR)  b3: Up to frequency (SU)*  b4: Overload (OL)*  b5: Instantaneous power failure (IPF)*  b6: Frequency detection (FU)*  b7: Alarm occurrence*</p> </div> </div> <p>(For example 1)  [Example 1] H02 ..... Forward running  [Example 2] H00 ..... Stop due to alarm occurrence</p> <p>*: Outputs change with the settings of Pr. 190 to Pr. 195 (output terminal function selection). For details, refer to the Inverter Instruction Manual.</p>	0	0	0	0	0	0	1	0
0	0	0	0	0	0	1	0				

## COMPUTER LINK FUNCTION

● FR-V500 series

No.	Item		Instruction Code	Description																
1	Operation mode	Read	H7B	H0000: Computer link operation H0001: External operation H0002: PU operation																
		Write	HFB	H0000: Computer link operation H0001: External operation H0002: PU operation (Setting is enabled only during switch over mode (Pr.79="6").)																
3	Run command		HFA	<p>H00 to HFF: Run command</p> <p>b15                      b7                      b0</p> <table border="1" style="margin-left: 20px;"> <tr> <td>0</td><td>0</td><td>0</td><td>0</td><td>0</td><td>0</td><td>0</td><td>0</td><td>0</td><td>0</td><td>0</td><td>0</td><td>0</td><td>0</td><td>1</td><td>0</td> </tr> </table> <p>(For example 1) [Example 1] H02 ..... Forward rotation</p> <p>[Example 2] H00 ..... Stop</p> <p>b0: - b1: Forward rotation (STF) b2: Reverse rotation (STR)* b3: Low speed (RL/D11)* b4: Middle speed (RM/D12)* b5: High speed (RH/D13)* b6: Second function selection (RT/D14)* b7: -</p> <p>*: The input signals marked * change with the settings of Pr. 180 to Pr. 183, Pr. 187 (input terminal function selection). For details, refer to the Inverter Instruction Manual.</p>	0	0	0	0	0	0	0	0	0	0	0	0	0	0	1	0
0	0	0	0	0	0	0	0	0	0	0	0	0	0	1	0					

No.	Item	Instruction Code	Description								
4	Inverter status monitor	H7A	<p>H00 to HFF: Inverter status monitor</p> <div style="display: flex; justify-content: space-around; align-items: center;"> <span>b7</span> <span>b0</span> </div> <table border="1" style="margin: auto; text-align: center;"> <tr> <td>0</td><td>0</td><td>0</td><td>0</td><td>0</td><td>0</td><td>1</td><td>0</td> </tr> </table> <p>For example 1)            [Example 1]H02 ..... Forward running            [Example 2]H00 ..... Stop due to alarm occurrence</p> <p>b0: Inverter running (RUN)            b1: Forward running            b2: Reverse running            b3: Inverter running (RUN/DO1)*            b4: Up to speed (SU/DO2)*            b5: Instantaneous power failure (IPF/DO3)*            b6: Speed detection            b7: Alarm occurrence*</p> <p>*: Outputs change with the settings of Pr. 190 to Pr. 192, Pr. 195 (output terminal function selection). For details, refer to the Inverter Instruction Manual.</p>	0	0	0	0	0	0	1	0
0	0	0	0	0	0	1	0				



### 4.13 Error Code List

The corresponding error code in the following list is displayed if an error is detected in any communication request data from the computer:



























Error Code	Item	Definition	Inverter Operation
H0	Computer NAK error	The number of errors consecutively detected in communication request data from the computer is greater than the permissible number of retries.	Brought to an alarm stop (E.OP1 to E.OP3) if error occurs continuously more than the permissible number of retries.
H1	Parity error	The parity check result does not match the specified parity.	
H2	Sum check error	Sum check code in the computer does not match that of the data received by the inverter.	
H3	Protocol error	Data received by the inverter is in the wrong syntax, data receive is not completed within the given time, or CR and LF are not as set in the parameter.	
H4	Framing error	The stop bit length is not as specified by initialization.	
H5	Overrun error	New data has been sent by the computer before the inverter completes receiving the preceding data.	
H6	_____	_____	_____
H7	Character error	The character received is invalid (other than 0 to 9, A to F, control code).	Does not accept receive data but is not brought to alarm stop.
H8	_____	_____	_____
H9	_____	_____	_____
HA	Mode error	Parameter write was attempted in other than the computer link operation mode or during inverter operation.	Does not accept receive data but is not brought to alarm stop.
HB	Instruction code error	The specified command does not exist.	
HC	Data range error	Invalid data has been specified for parameter write, frequency setting, etc.	
HD	_____	_____	_____
HE	_____	_____	_____
HF	_____	_____	_____

## 4.14 ASCII Code List (Reference)

### ASCII codes

 Most significant 4 bits
 
 : Indicates codes often used.

Least significant 4 bits

	0	1	2	3	4	5	6	7	8	9	A	B	C	D	E	F
0	 NUL	TC <sub>1</sub> (DEL)	(SP)	0	@	P	'	 p								
1	TC <sub>1</sub> (SOH)	DC <sub>1</sub>	!	1	A	Q	 a	 q								
2	TC <sub>2</sub> (STX)	DC <sub>2</sub>	"	2	B	R	 b	 r								
3	TC <sub>3</sub> (ETX)	DC <sub>3</sub>	#	3	C	S	 c	 s								
4	TC <sub>4</sub> (EOT)	DC <sub>4</sub>	\$	4	D	T	 d	 t								
5	TC <sub>5</sub> (ENQ)	TC <sub>5</sub> (NAK)	%	5	E	U	 e	 u								
6	TC <sub>6</sub> (ACK)	TC <sub>9</sub> (SYN)	&	6	F	V	 f	 v								
7	BEL	TC <sub>10</sub> (ETB)	'	7	G	W	 g	 w								
8	FE <sub>0</sub> (BS)	CAN	(	8	H	X	 h	 x								
9	FE <sub>1</sub> (HT)	EM	)	9	I	Y	 i	 y								
A	FE <sub>2</sub> (LF)	SUB	*	:	J	Z	 j	 z								
B	FE <sub>3</sub> (VT)	ESC	+	;	K	[	 k	{								
C	FE <sub>4</sub> (FF)	IS <sub>4</sub> (FS)	,	<	L	\	 l									
D	FE <sub>5</sub> (CR)	IS <sub>3</sub> (GS)	-	=	M	]	 m	}								
E	SO	IS <sub>2</sub> (RS)	.	>	N	^	 n	~								
F	SI	IS <sub>1</sub> (US)	/	?	O	_	 o	DEL								

Example: Conversion of ASCII code H 3 7 results in 7.

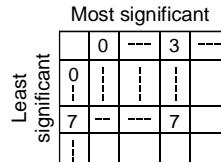
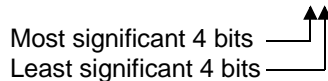



## 4.15 Specifications

- |                                  |   |
|----------------------------------|---|
| 1) Power supply                  | ● Control power: Supplied by the inverter                         |
| 2) Conforming standard           | ● Communication power: 5VDC, max. 60mA                            |
| 3) Transmission form             | ● Shared between RS-422 and RS-485 [EIA Standard]                 |
| 4) Communication cable           | ● Multidrop link system   |
| 5) Transmission distance         | ● Twisted pair cable  |
| 6) Number of inverters connected | ● Max. 500m overall   |
| 7) Applicable computer           | ● Up to 10 inverters for RS-422 computer interface                |
| 8) Communication specifications  | ● Up to 32 inverters for RS-485 computer interface                |
|                                  | ● Computer with RS-422 or RS-485 interface function <sup>*1</sup> |

Conforming standard		RS-485 Standard	
Number of inverters connected		1: N (max. 32 inverters)	
Communication speed		19200/9600 <sup>*2</sup> /4800/2400/1200/600/300	
Control procedure		Asynchronous system	
Communication method		Half duplex system	
Communication specifications	Station number setting	0 to 31 (Pr. 331 "station number" setting)	
	Character system	ASCII (7 bits/8 bits) selectable	
	Stop bit length	1 bit/2 bits selectable	
	Terminator	CR/LF (yes <sup>*2</sup> /no selectable)	
	Check system	Parity check	Yes (even <sup>*2</sup> /odd)/no selectable
		Sum check	Yes
	Waiting time setting	Yes <sup>*2</sup> /no selectable	

\*1.By using a converter, a computer with RS-232C interface function is also applicable.

\*2.Factory setting

9) Response time

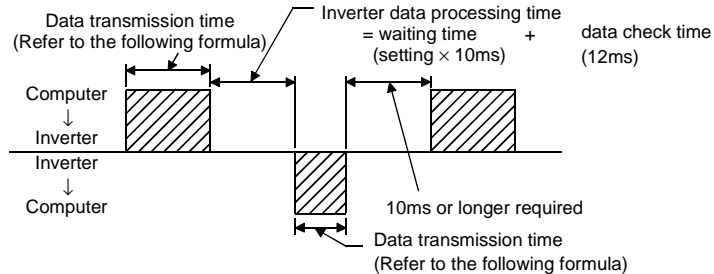

**[Data transmission time formula]**

$$\frac{1}{\text{Communication speed (Baudrate)}} \times \text{Number of data characters(*)} \times \text{Communication specifications* (Total number of bits)} = \text{Data transmission time (s)}$$

\*Refer to the Inverter Instruction Manual (Pr. 117 to Pr. 124).

\*Communication specifications (Refer to the following table)

Name	Number of Bits
Stop bit length	1 bit
	2 bits
Data length	7 bits
	8 bits

Name	Number of Bits	
Parity check	Yes	1 bit
	No	0 bits
Start bit	1 bit	

**REMARKS**

1 bit is always required for the start bit.

Minimum total number of bits: 9 bits, maximum total number of bits: 12 bits

## COMPUTER LINK FUNCTION

- Example: Response time when forward (reverse) rotation command is given by communication

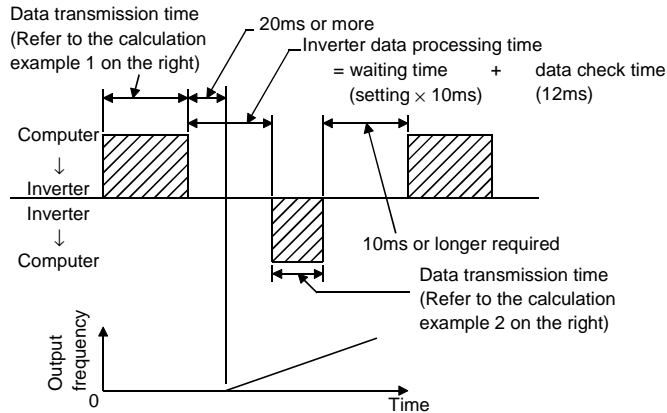

<Calculation example 1>

- 1) Baudrate = 9600 bps, number of data characters = 12, stop bit length = 2 bits, data length = 8 bits, parity check = yes, CR, LF instructions = yes

$$\frac{1}{9600} \times 12 \times 12 = 0.015\text{s} (15.0\text{ms})$$

- 2) Same conditions as above with the exception of baudrate = 19200 bps

$$\frac{1}{19200} \times 12 \times 12 = 0.0075\text{s} (7.5\text{ms})$$

- 3) Same conditions as above with the exception of baudrate = 300 bps

$$\frac{1}{300} \times 12 \times 12 = 0.48\text{s} (480\text{ms})$$

<Calculation example 1>  
Format A'

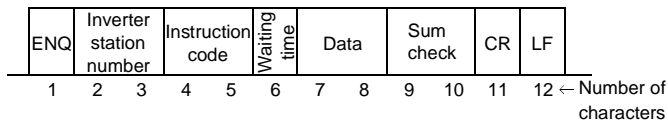

<Calculation example 2>  
Format G

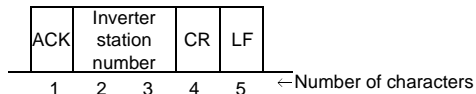

<Calculation example 2>

1) Baudrate = 9600 bps, number of data characters = 5, stop bit length = 2 bits, data length = 8 bits, parity check = yes, CR, LF instructions = yes

$$\frac{1}{9600} \times 5 \times 12 = 0.00625s \text{ (6.25ms)}$$

2) Same conditions as above with the exception of baudrate = 19200 bps

$$\frac{1}{19200} \times 5 \times 12 = 0.003125s \text{ (3.125ms)}$$

3) Same conditions as above with the exception of baudrate = 300 bps

$$\frac{1}{300} \times 5 \times 12 = 0.2s \text{ (200ms)}$$

REVISIONS

\*The manual number is given on the bottom left of the back cover.

Print Date	*Manual Number	Revision	
Oct., 1997	IB(NA)-66835-A	First edition	
Jan., 2002	IB(NA)-66835-B	<table border="1"><tr><td data-bbox="515 259 656 307">Addition</td></tr></table> Adaptable inverters	Addition
Addition			