

Установка 300 мм передней панели сверху

B 14.3.1.1

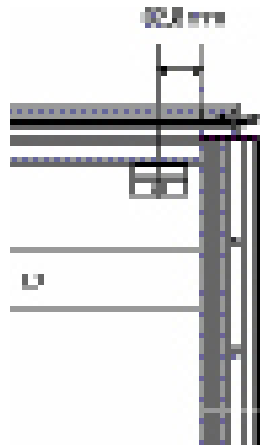

B 14.3.1.2

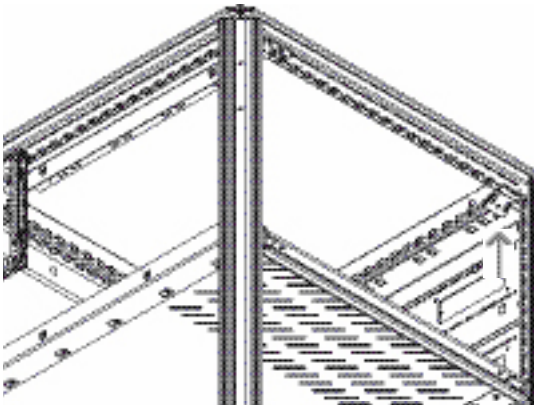
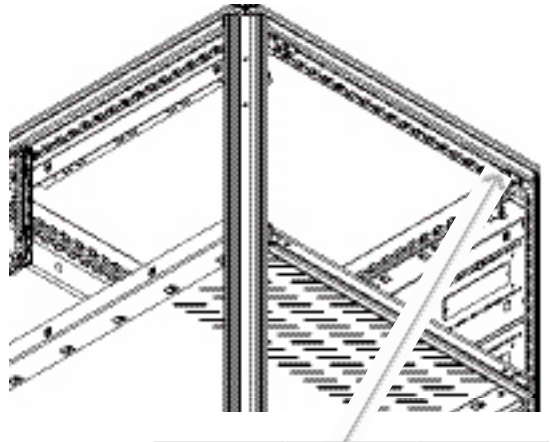

B 14.3.2.1

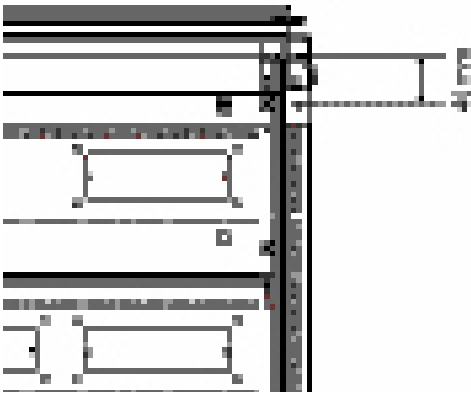

		T 25	5 Nm

B 14.3.2.2
IP 54 / IP 43

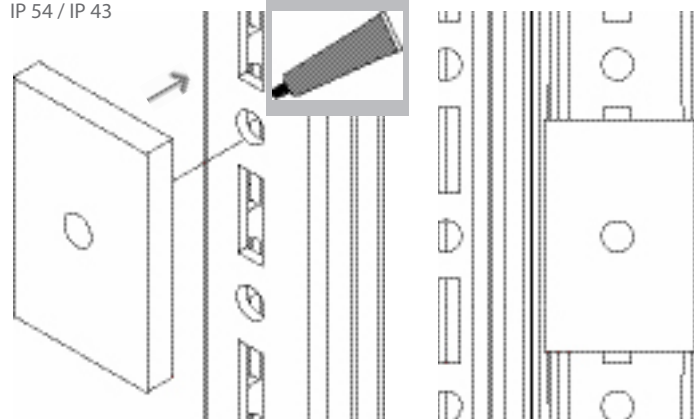

B 14.3.2.3

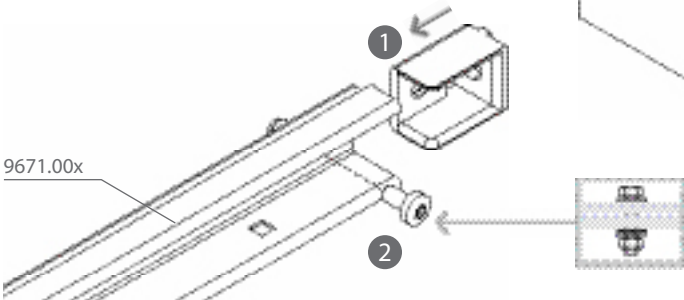

B 14.3.2.4

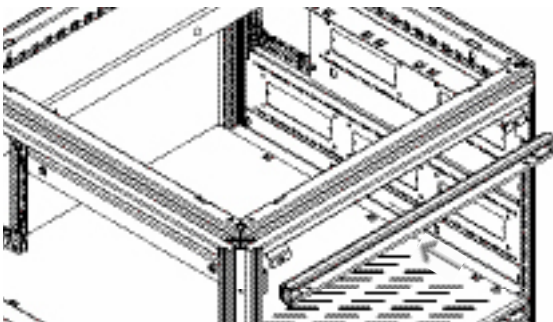

B 14.3.2.5



		T 25	5 Nm

Установка 100 мм передней панели сверху

B 14.3.2.6

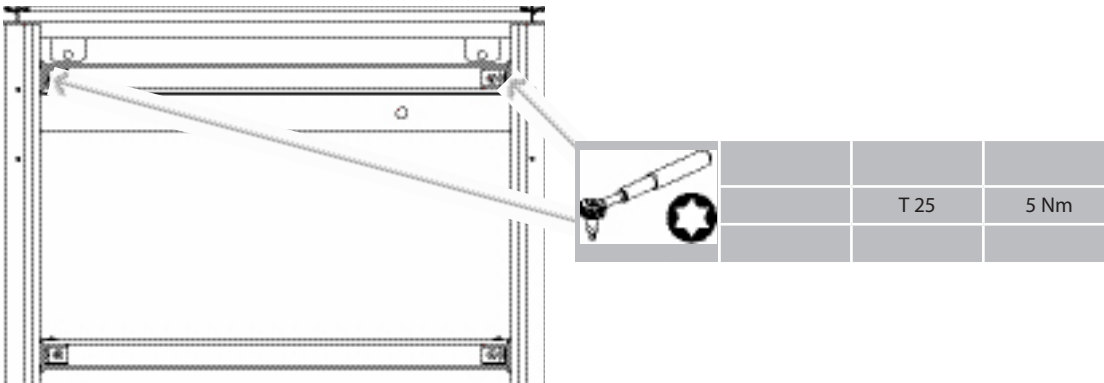

B 14.3.3.1

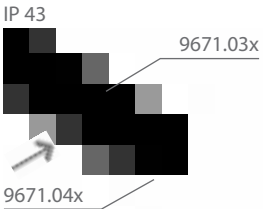

B 14.3.3.2

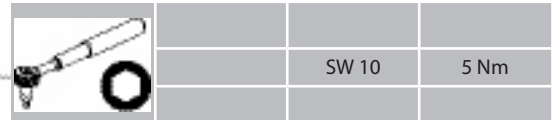
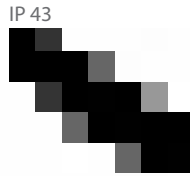

B 14.3.3.3

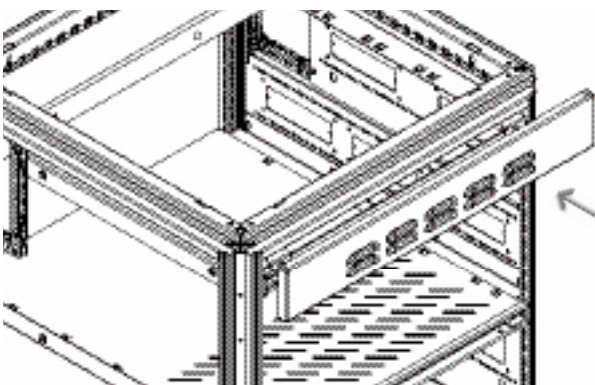

B 14.3.3.4

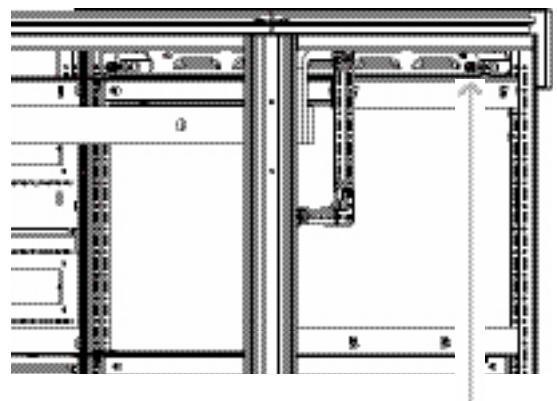

B 14.3.3.5

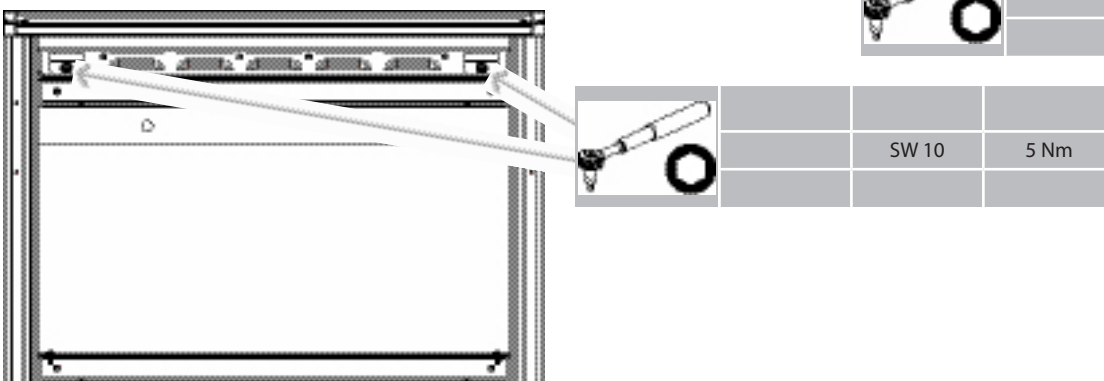

Установка 300 мм передней панели снизу

B 14.3.4.1

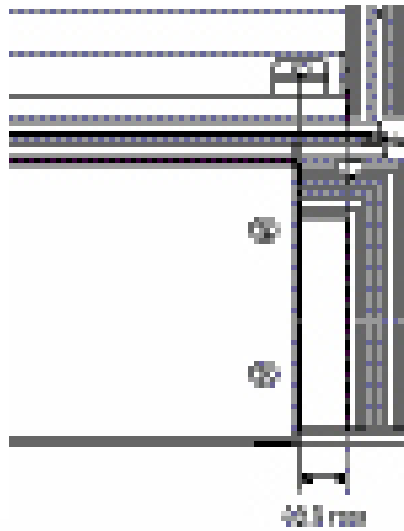
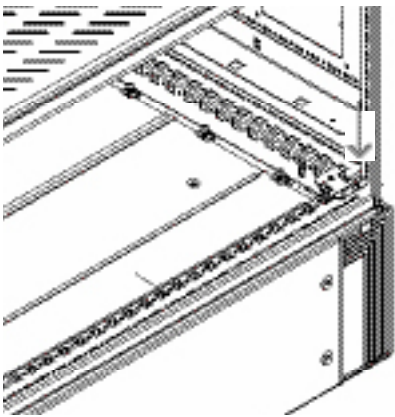

B 14.3.4.2

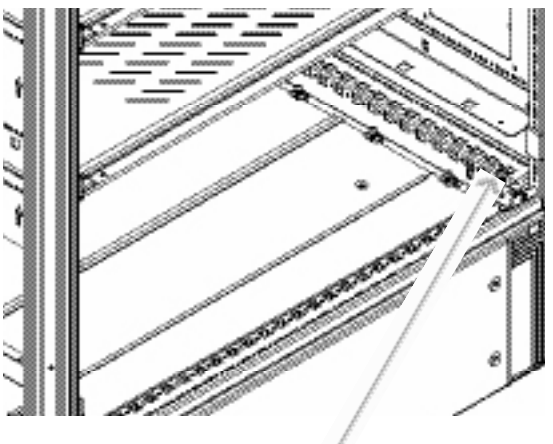

B 14.3.5.1

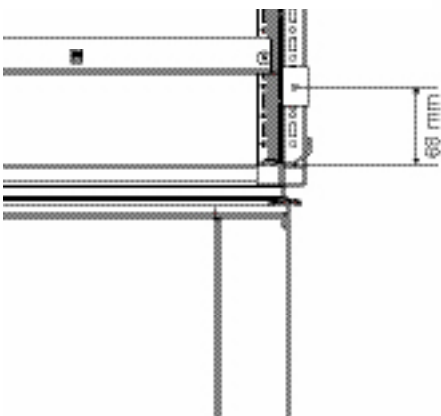

		T 25	5 Nm
--	--	------	------

B 14.3.5.2
IP 54 / IP 43

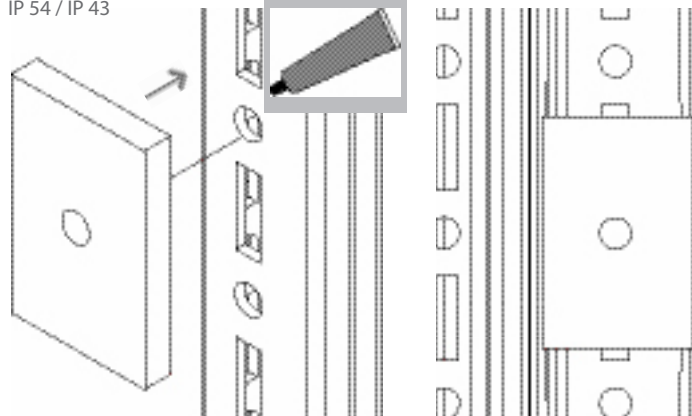

B 14.3.5.3

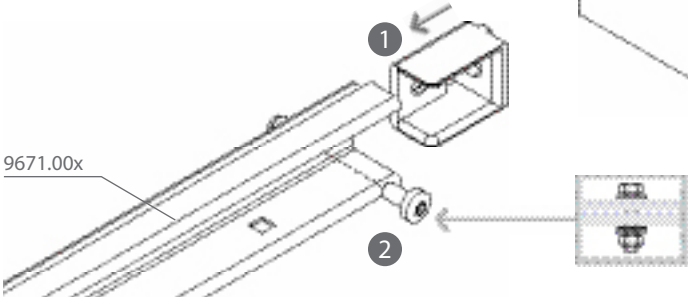

B 14.3.5.4

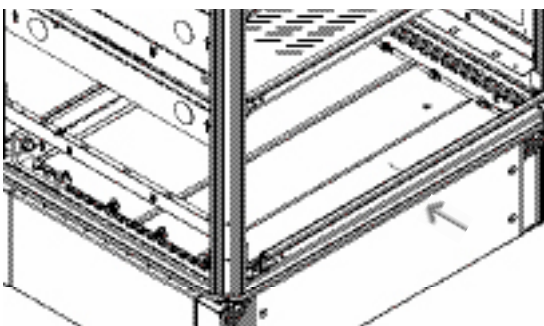

B 14.3.5.5



		T 25	5 Nm
--	--	------	------

Установка 100 мм передней панели снизу

B 14.3.5.6

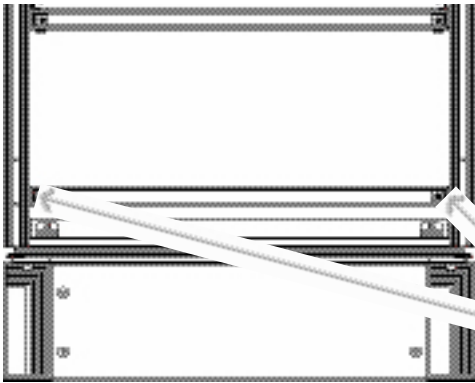

		T 25	5 Nm

B 14.3.6.1

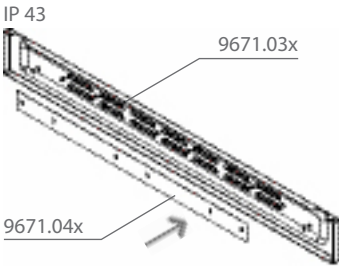

B 14.3.6.2

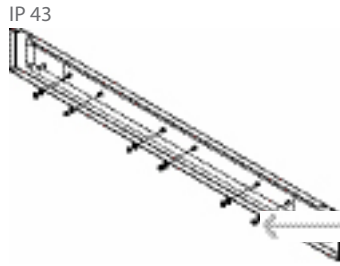

		SW 10	5 Nm

B 14.3.6.3

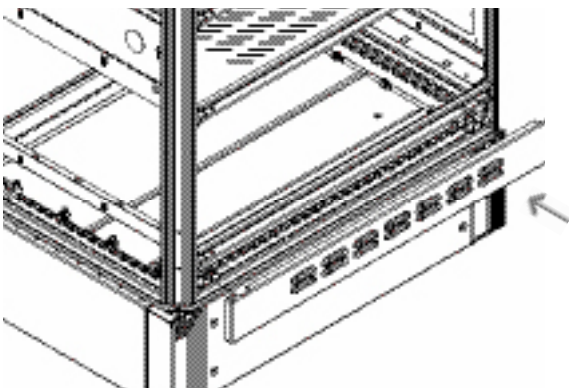

B 14.3.6.4

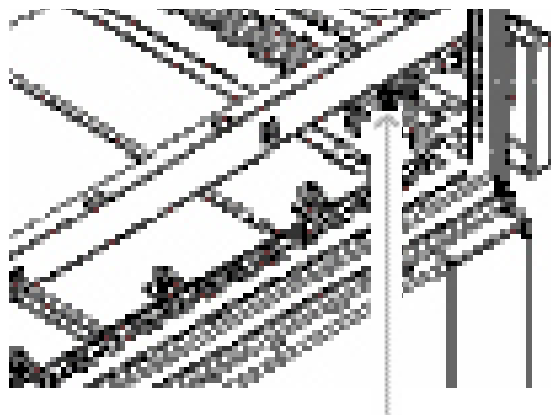

		SW 10	5 Nm

B 14.3.6.5

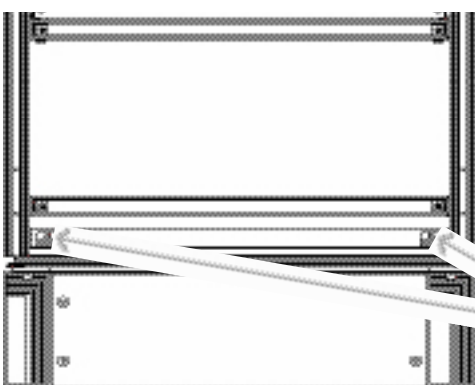

		SW 10	5 Nm

Установка модульных стенок и монтажных уголков

B 15.1

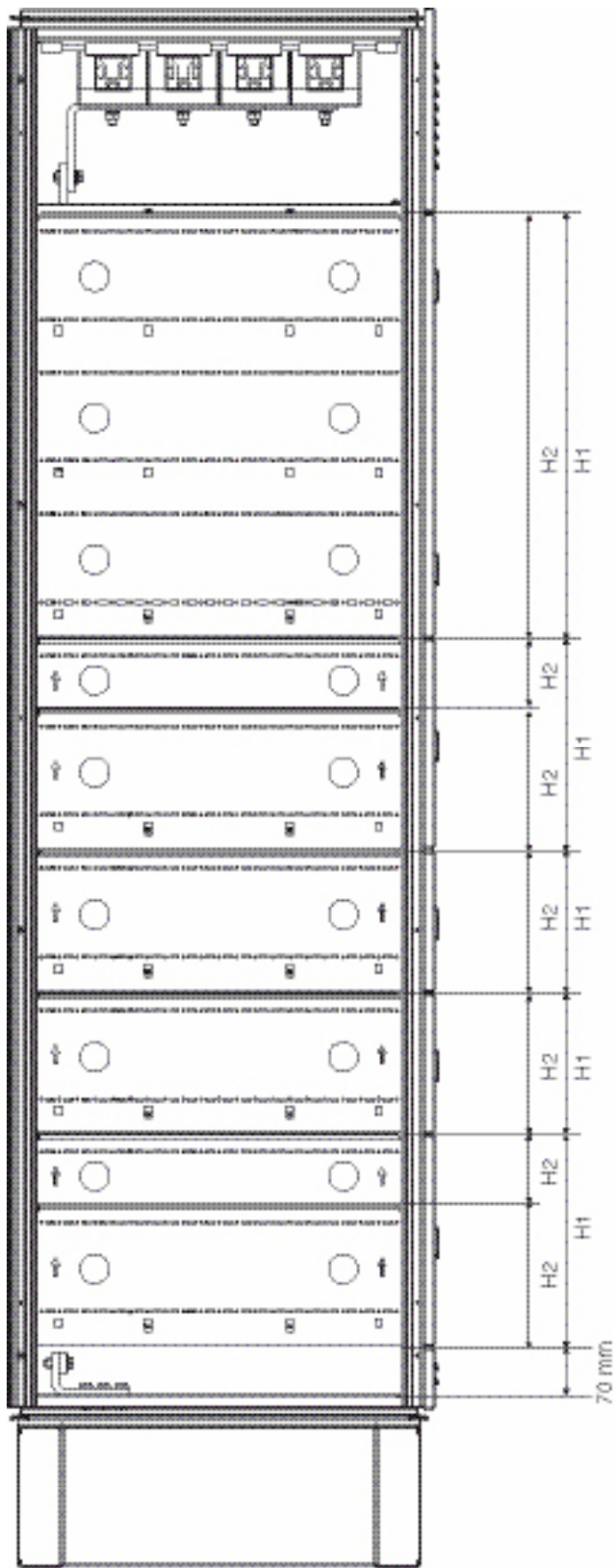

H1	H2
150mm	1 x 150mm
200mm	1 x 200mm +
250mm	1 x 150mm + 1 x 100mm
300mm	1 x 200mm + 1 x 100mm
400mm	2 x 200mm
600mm	1 x 600mm
800mm	1 x 600mm + 1 x 200mm
1000mm	1 x 600mm + 2 x 200mm

H2		
100mm	96730x1	96731x1
150mm	96730x5	96731x5
200mm	96730x2	96731x2
600mm	96730x6	96731x6

B 15.2

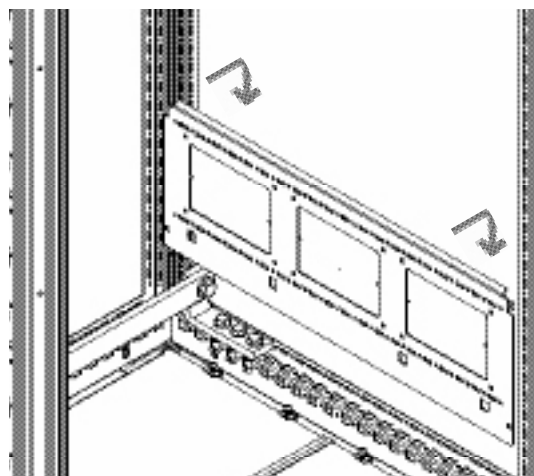

B 15.3

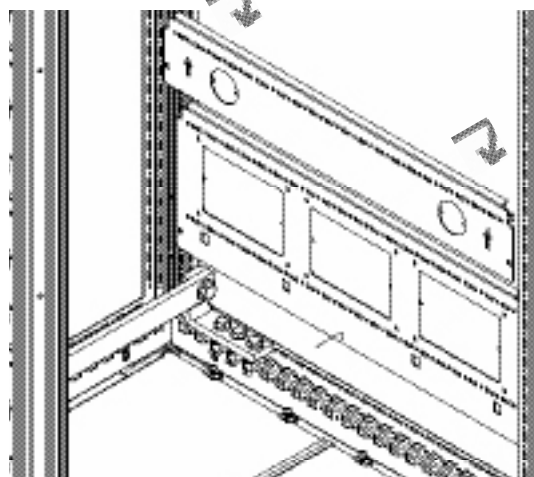

Установка модульных стенок и монтажных уголков

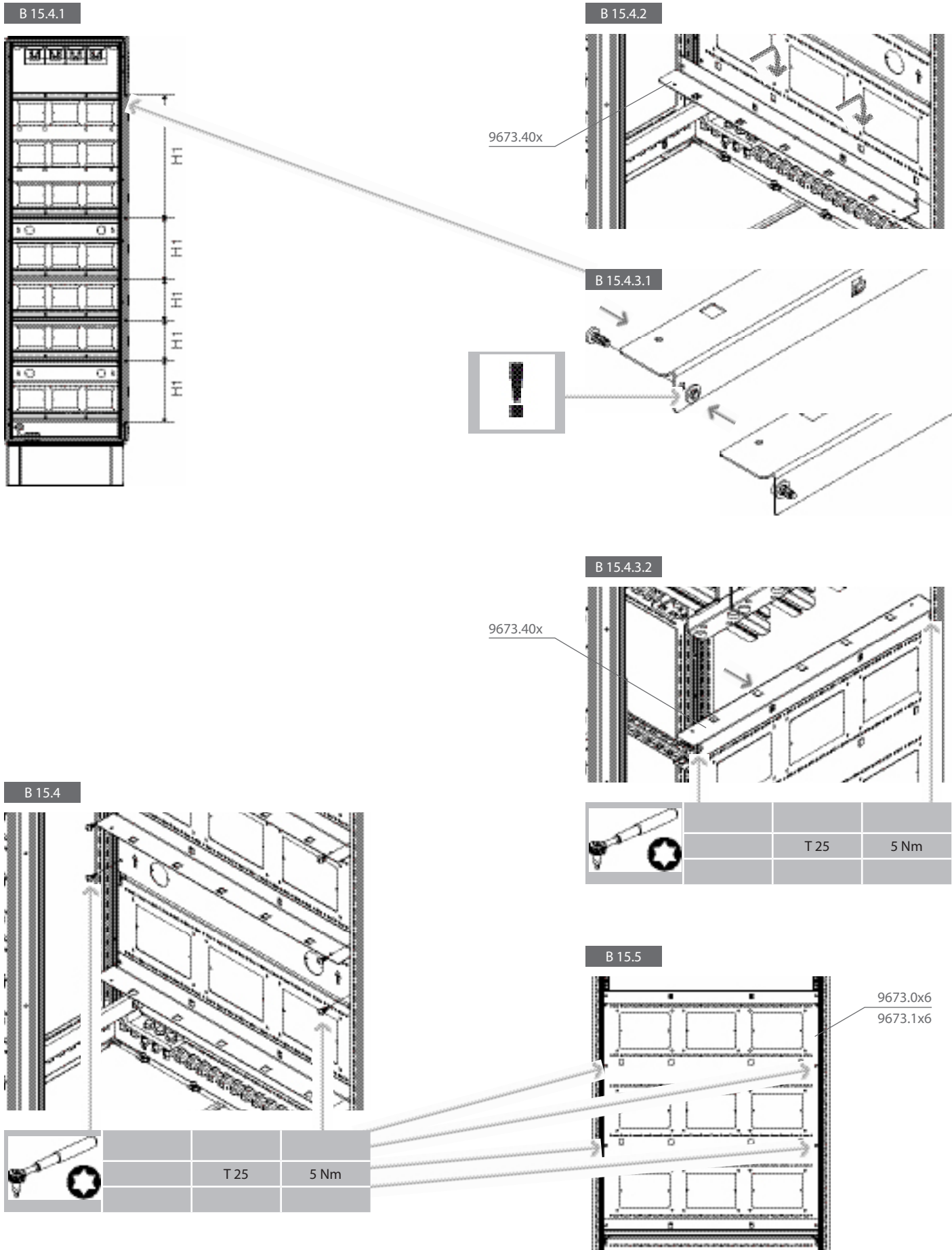

Установка монтажных плат

Установка монтажных плат Assembling the mounting plate inside of functional space

B 16.1.1

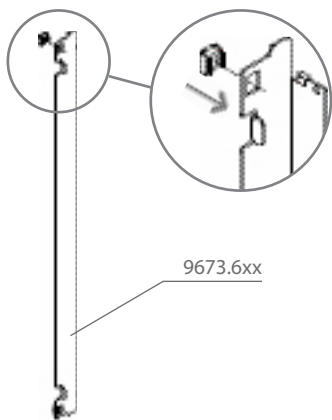

B 16.1.2

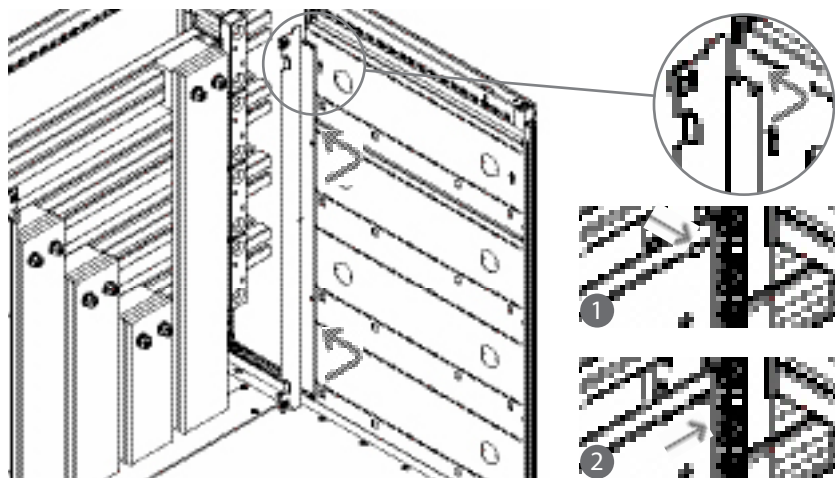

B 16.1.3

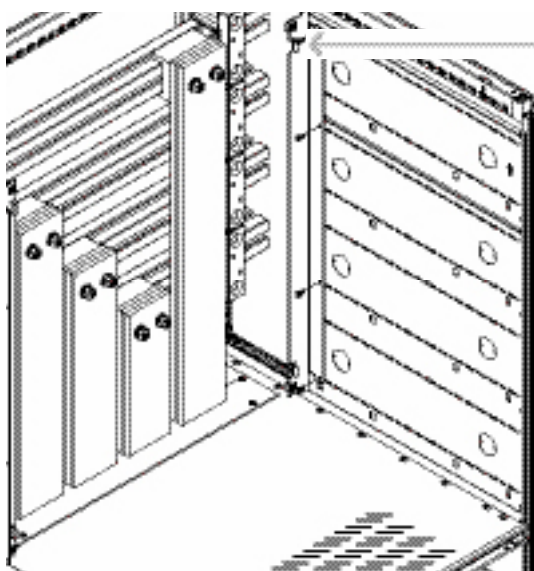

			
		T 25	5 Nm

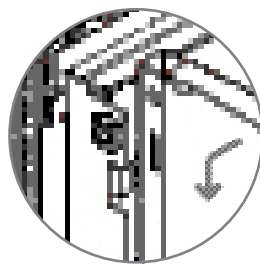

			
		T 30	9 Nm

B 16.2.1

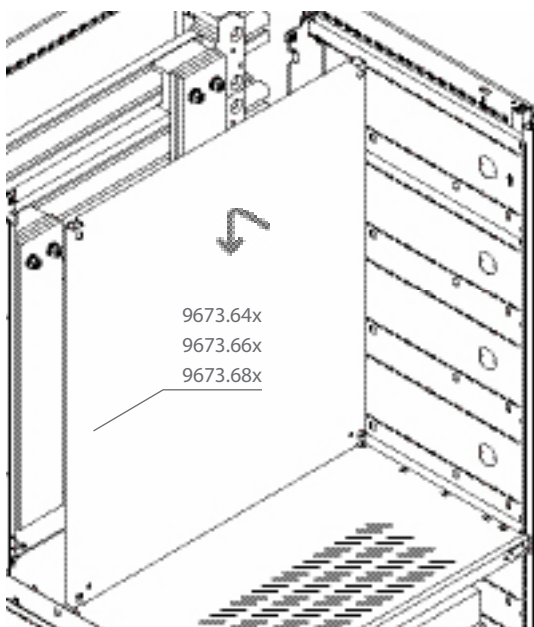

B 16.2.2

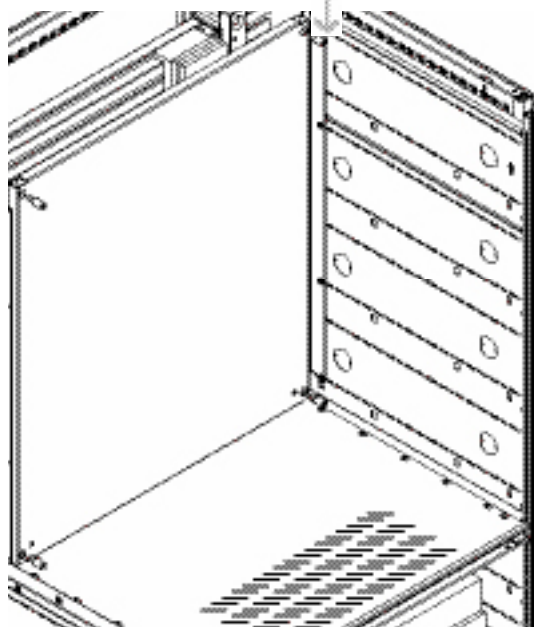

Установка монтажных плат

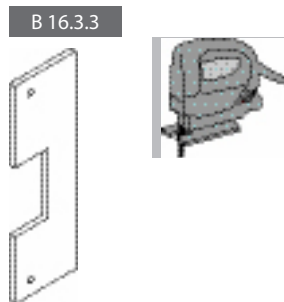
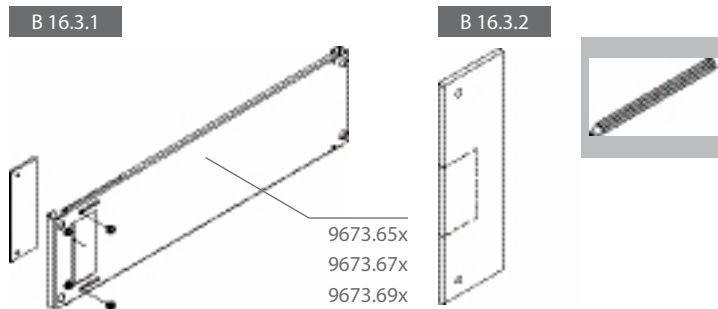

			
		T 30	9 Nm

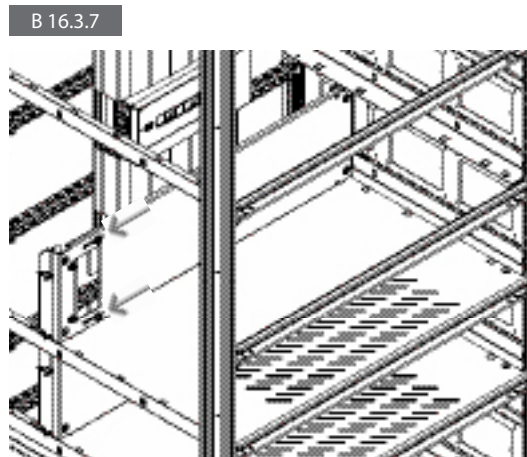
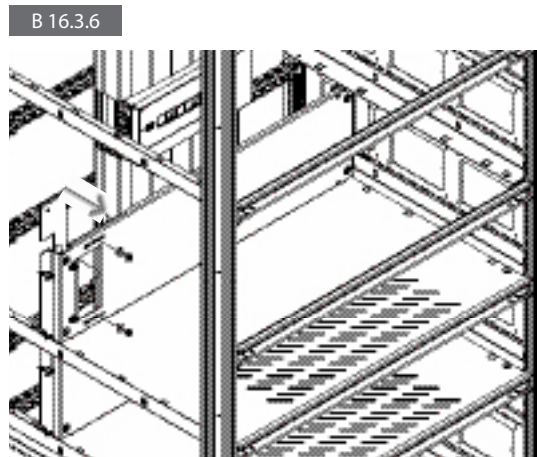

			
		T 30	2 Nm

Установка монтажной платы и рамы под DIN-аппараты

Установка монтажной платы и рамы под DIN аппараты/Assembling the mounting plate and support frame inside of functional space

B 17.1.1

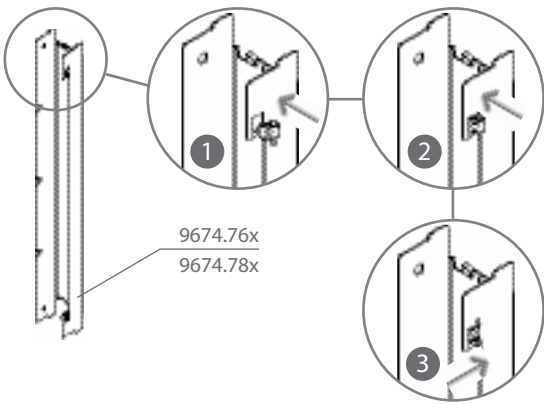

B 17.1.2

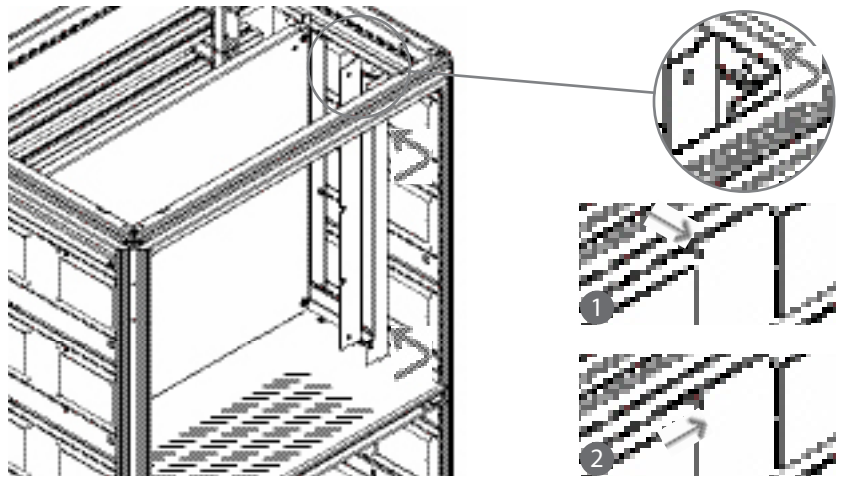

B 17.1.3

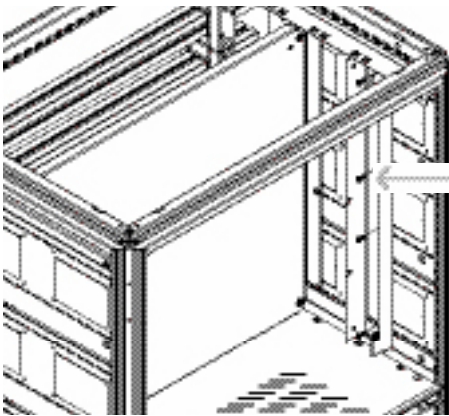

B 17.2.1

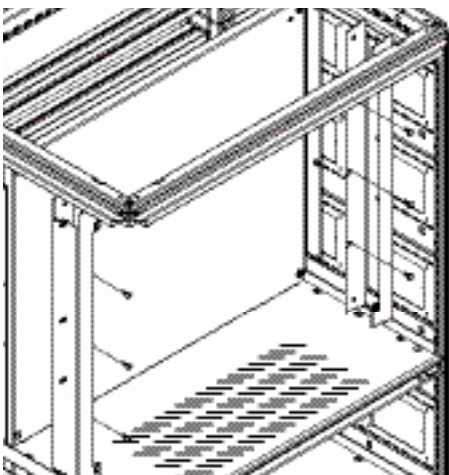

B 17.2.2

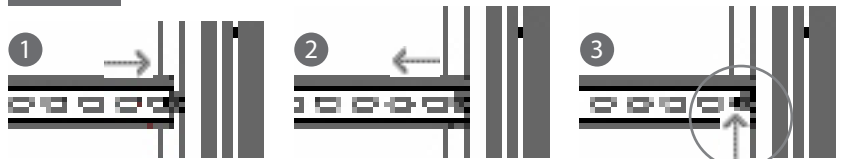

B 17.2.3

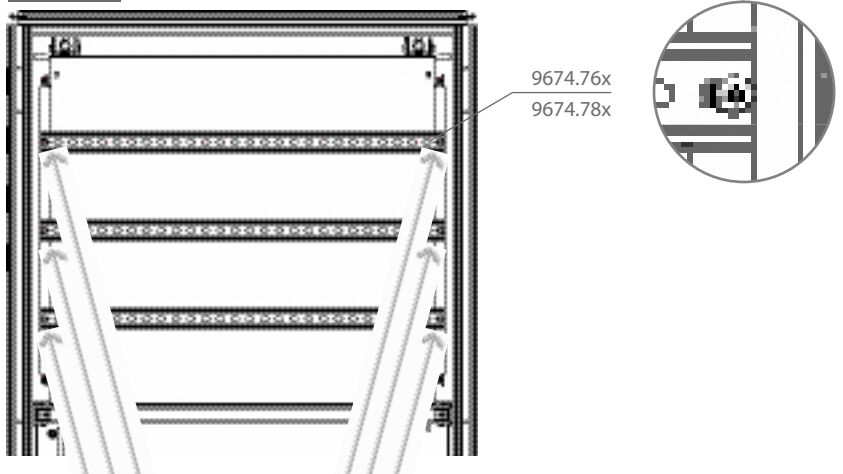

Установка монтажной платы и рамы под DIN-аппараты

B 17.3.1

W = 800mm, 9674.78x

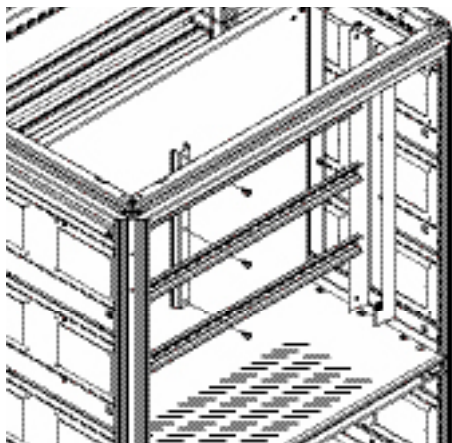

B 17.3.2

W = 800mm

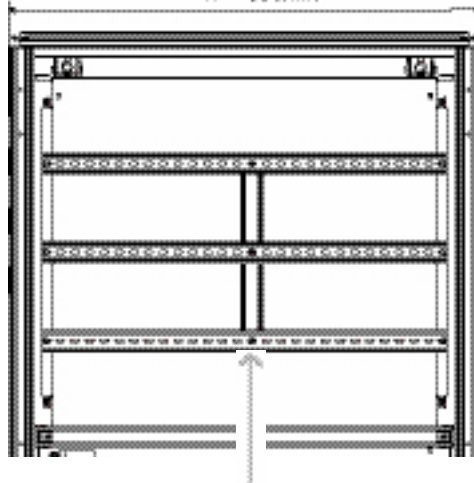

		T 25	5 Nm

B 17.4.1

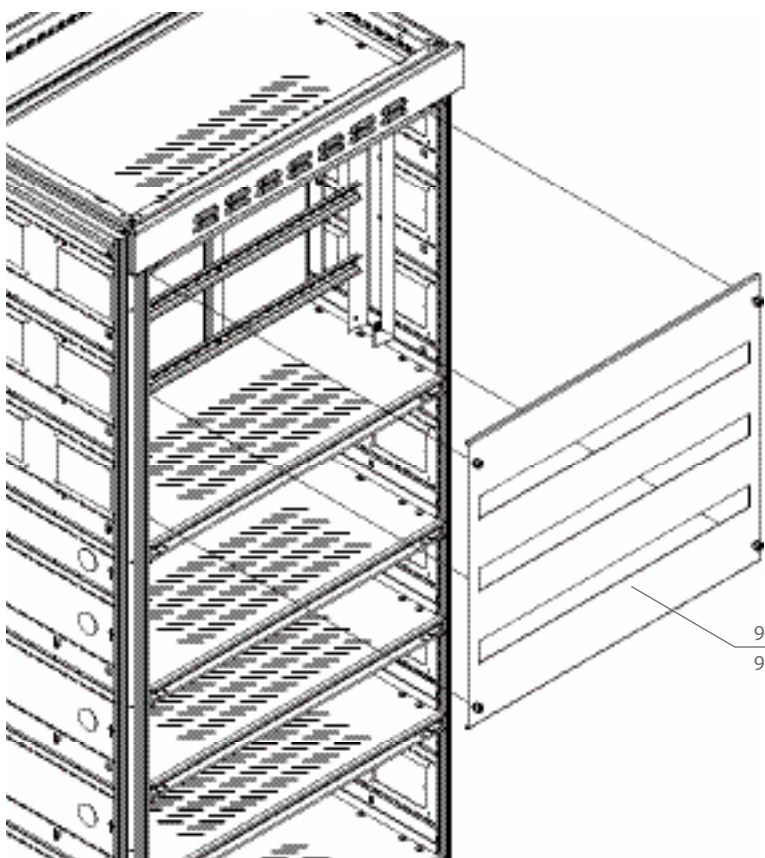

9674.76x
9674.78x

B 17.4.2

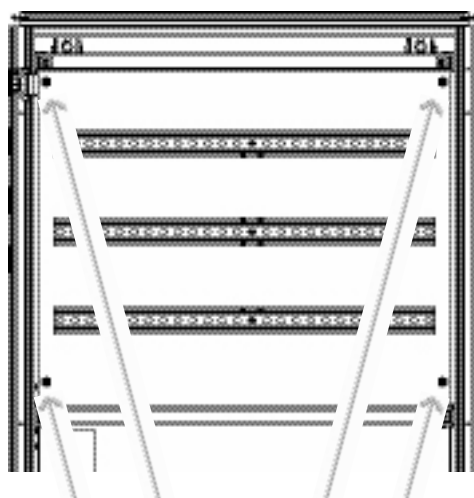

		T 25	3-5 Nm

Установка частичной двери

B 18.1.1

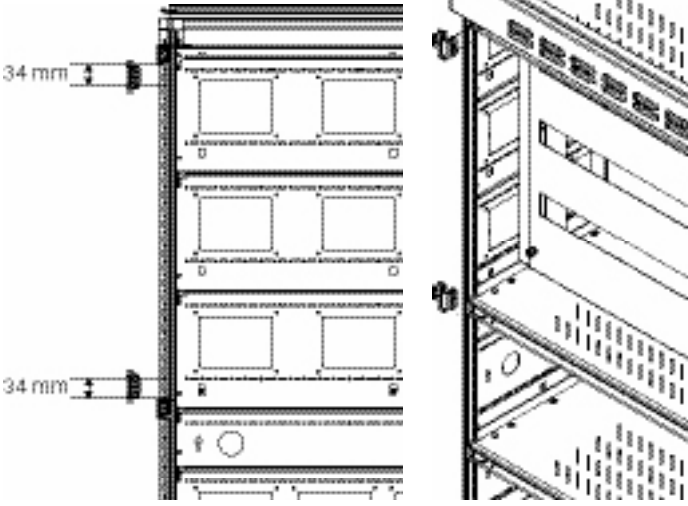

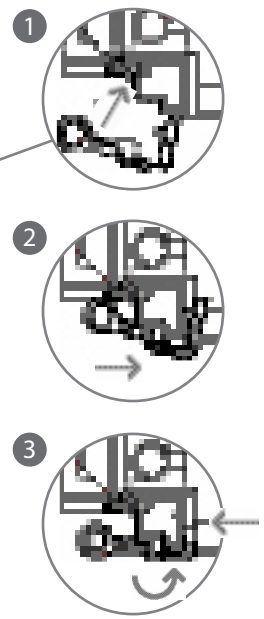
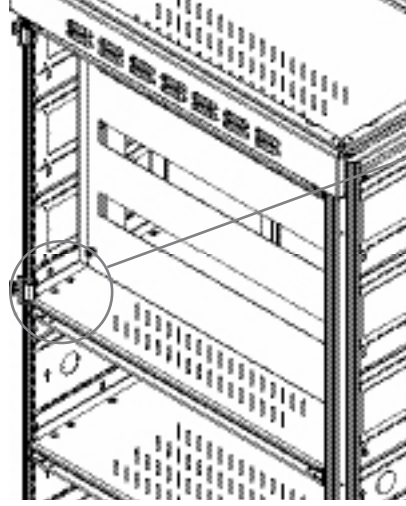

B 18.1.2

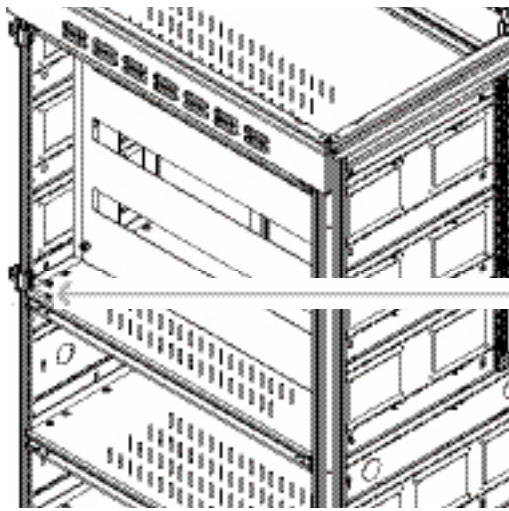

B 18.1.3



				T 25	5 Nm
---	---	--	--	------	------

B 18.1.4

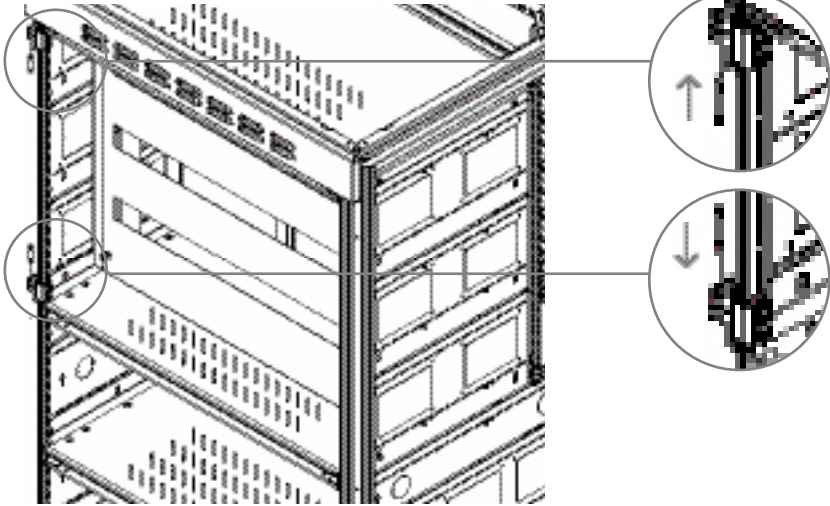

B 18.1.5

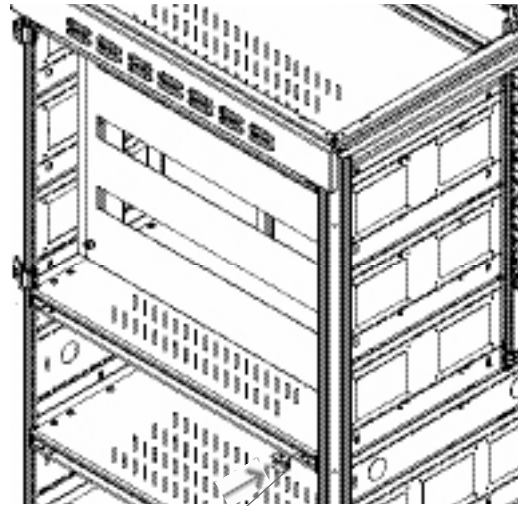

9671.00x

Установка частичной двери

B 18.2.1

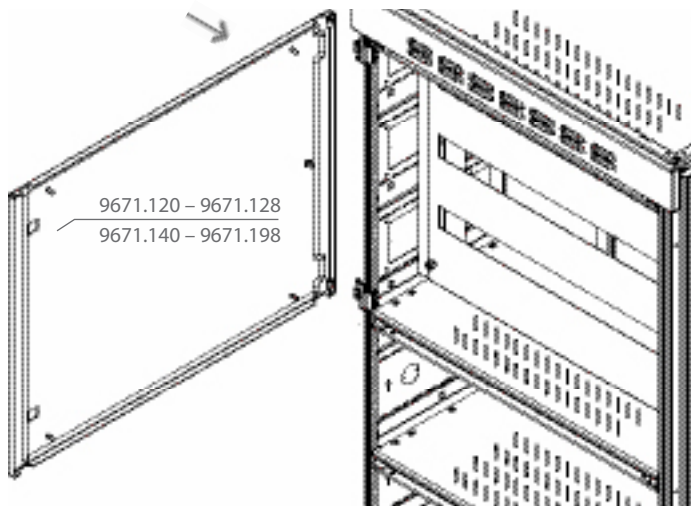

B 18.2.2

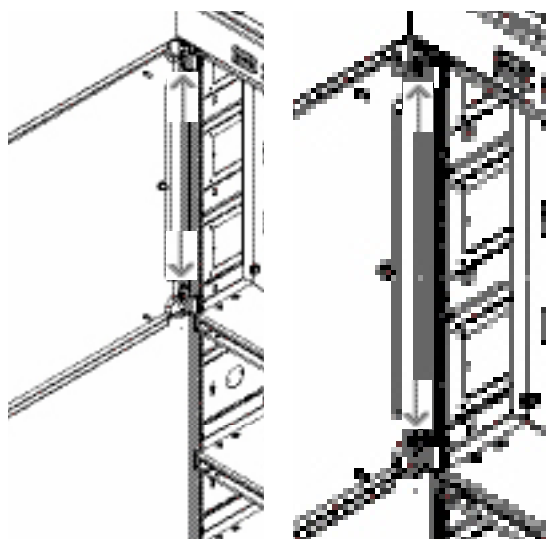

B 18.3.1

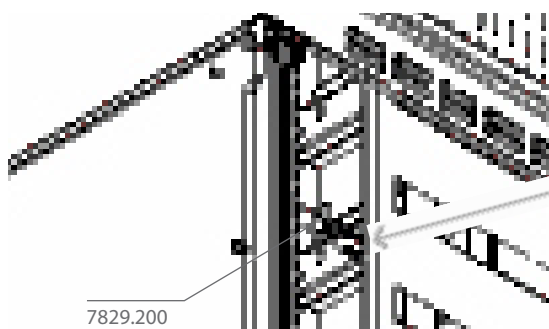

		T 25	5 Nm
--	--	------	------

B 18.3.2

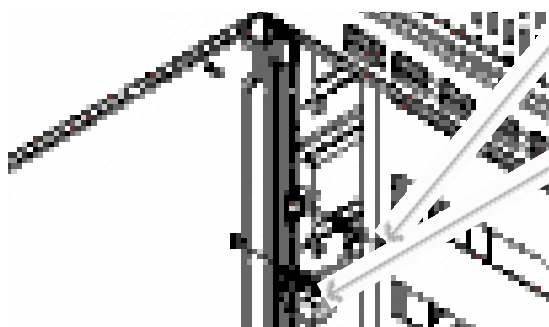

		SW 12/13	8-10 Nm
--	--	----------	---------

		SW 12/13	8-10 Nm
--	--	----------	---------

		T 25	2,5 Nm
--	--	------	--------

B 18.4.1

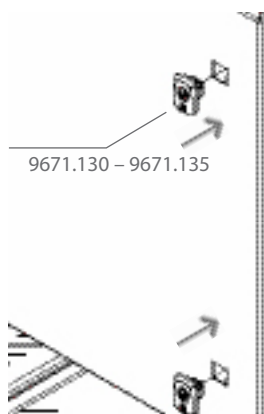

B 18.4.2

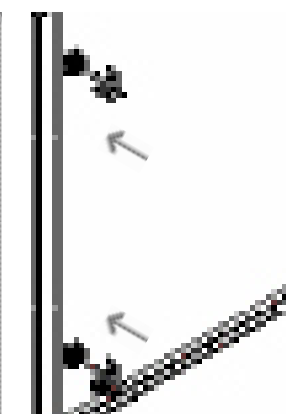

B 18.4.3



B 18.4.4

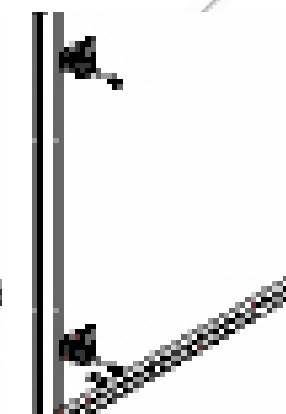

Установка потолочной панели

Установка потолочной панели Assembling the roof plate

B 19.1.1

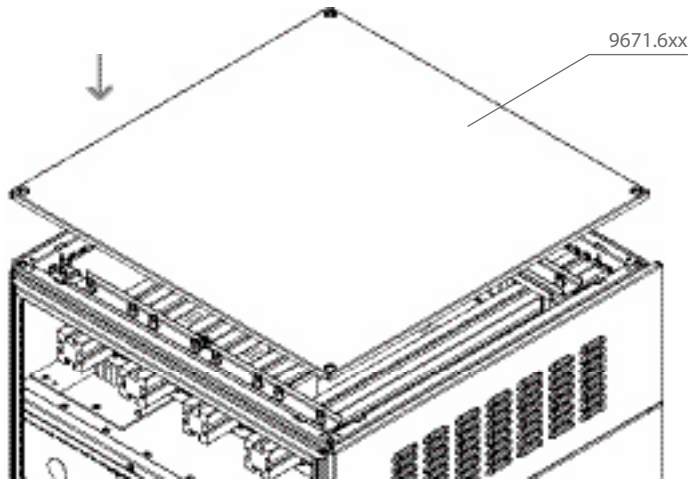

B 19.1.2

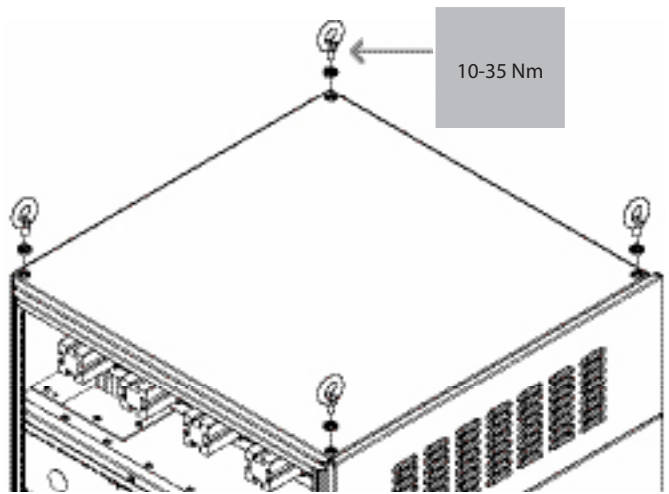

B 19.2.1

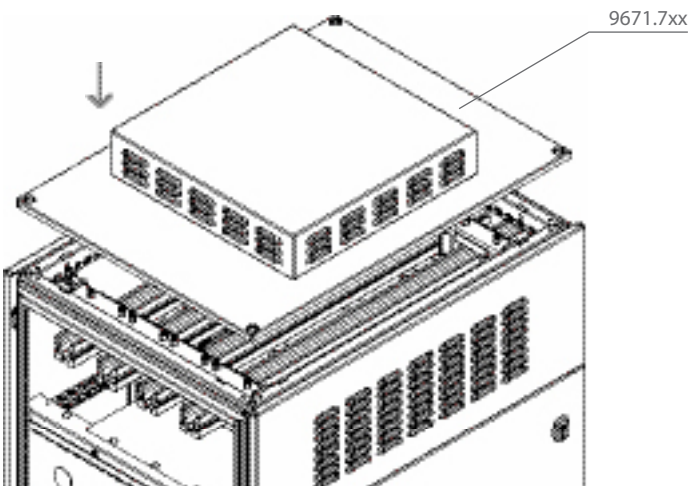

B 19.2.2

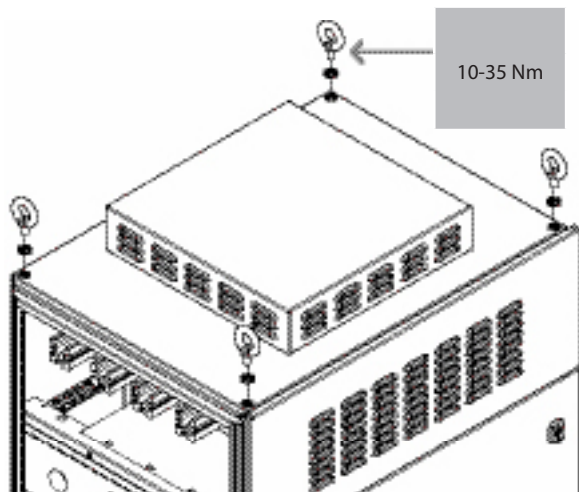

B 19.3.1

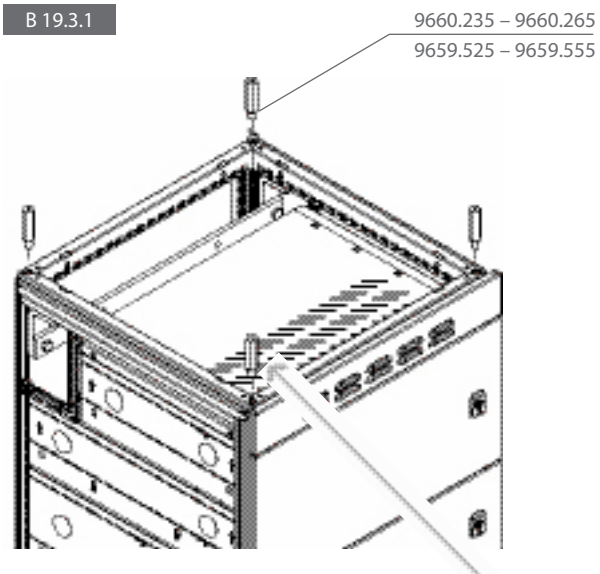

B 19.3.2

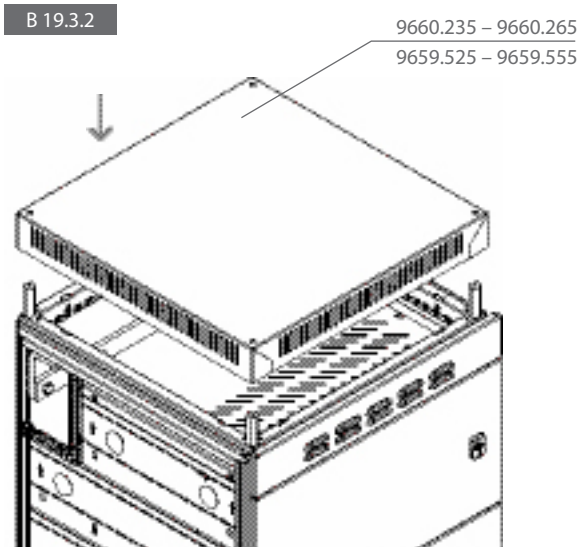

			
		SW 19	10-35 Nm

Установка потолочной панели

В 19.3.3

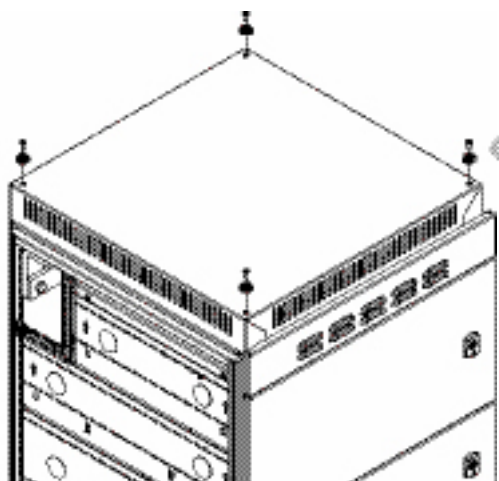

В 19.4.1

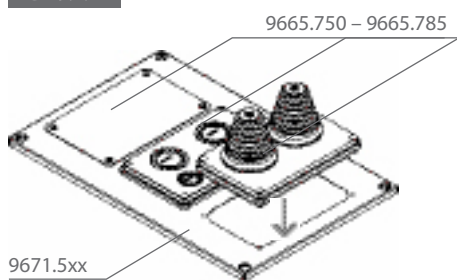

В 19.4.2

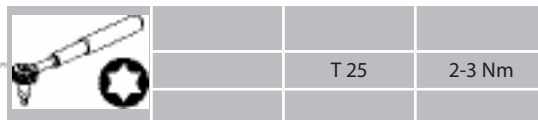
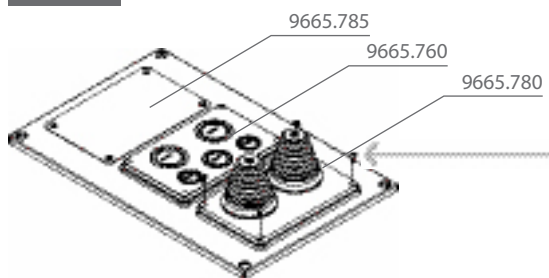

В 19.4.3

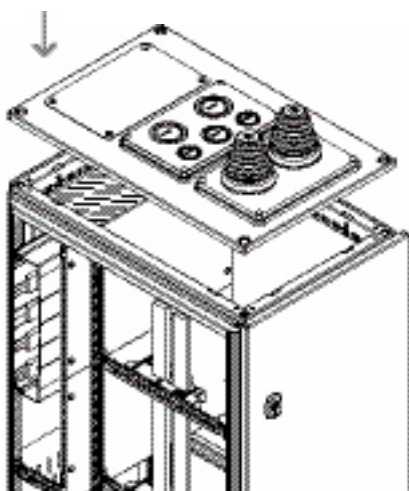

В 19.4.4

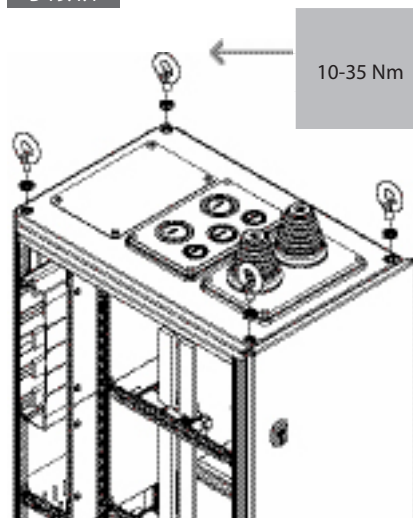

Установка потолочной панели

B 19.5.1

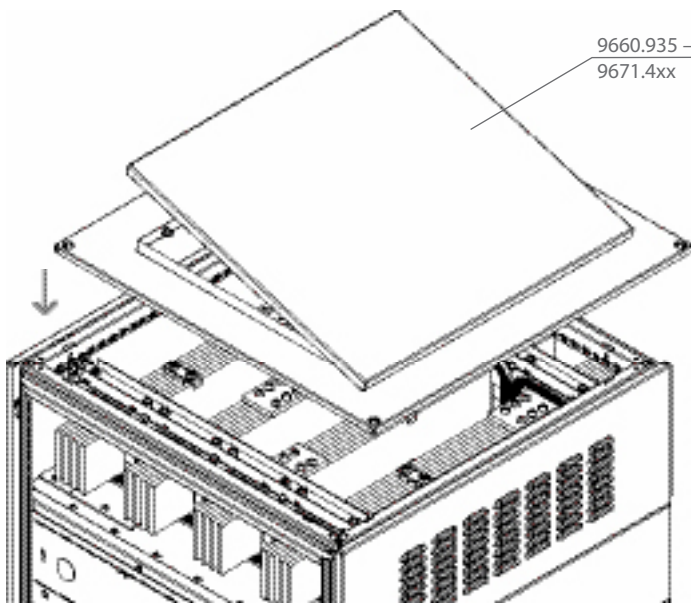

B 19.5.2

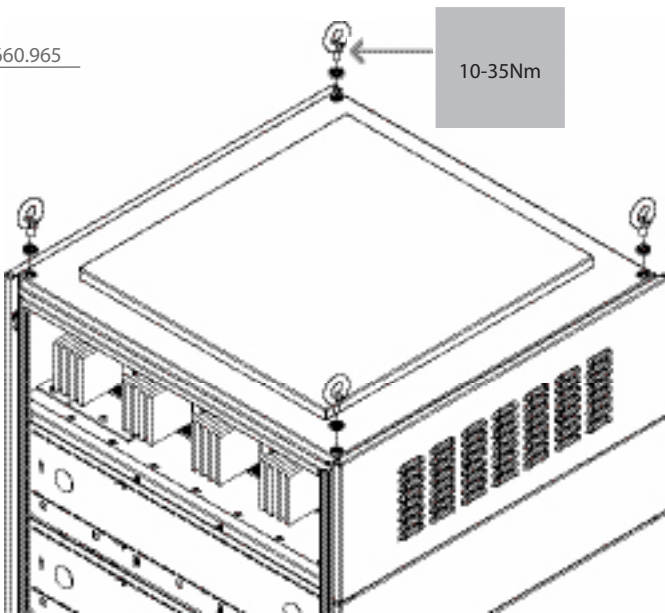

B 19.5.3

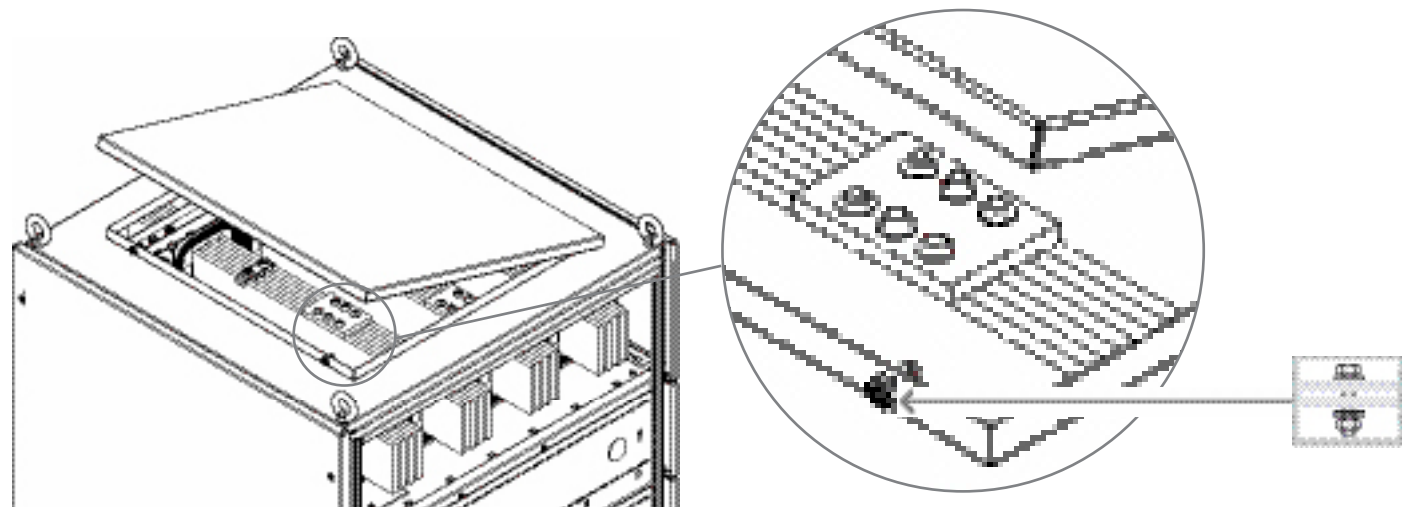

B 19.5.4

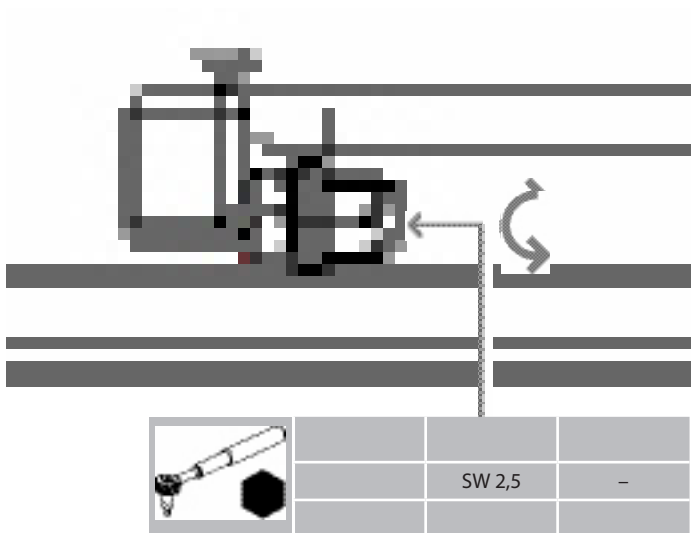

B 19.5.5

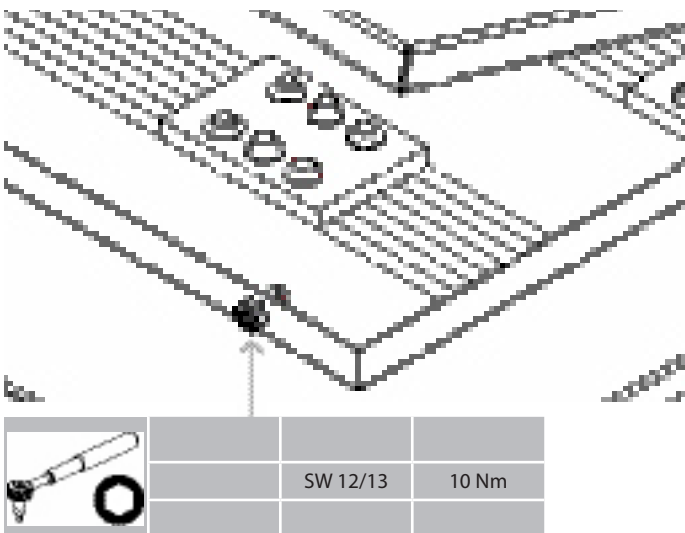

Сборка панели секционной перемычки

B 20.1.1.1

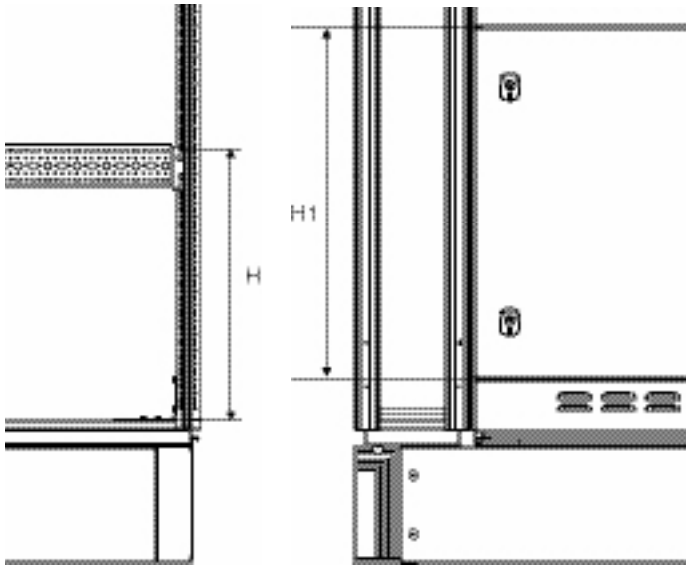

	H		
	direkt unter Schalter directly below the circuit breaker		
H1	600 mm	800 mm	1000 mm
Maxi-PLS 1600/2000	406 mm	606 mm	806 mm
Maxi-PLS 3200	406 mm	606 mm	806 mm
Flat-PLS 60	256 mm	456 mm	656 mm
Flat-PLS 100	256 mm	456 mm	656 mm

B 20.1.1.2

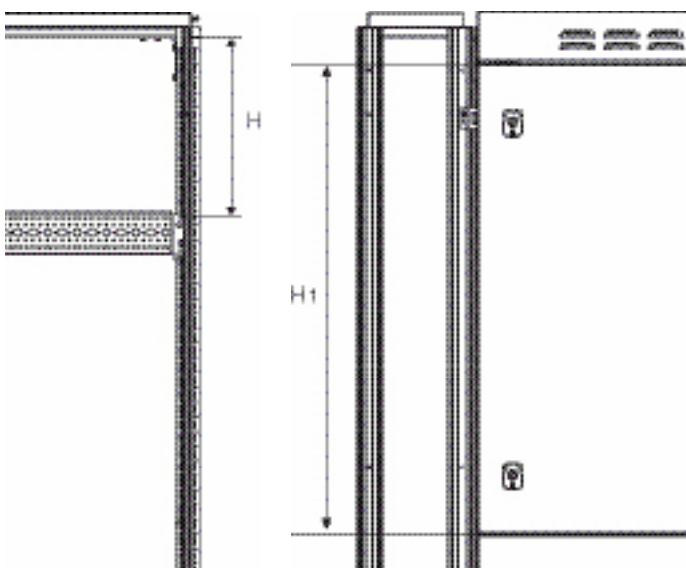

	H		
	direkt über Schalter directly above the circuit breaker		
H1	600 mm	800 mm	1000 mm
Maxi-PLS 1600/2000	556 mm	756 mm	956 mm
Maxi-PLS 3200	556 mm	756 mm	956 mm
Flat-PLS 60	581 mm	781 mm	981 mm
Flat-PLS 100	631 mm	831 mm	1031 mm

	H	
	Rückbereich oben upper rear section	
Maxi-PLS 1600/2000	531 mm	
Maxi-PLS 3200	731 mm	
Flat-PLS 60	631 mm	
Flat-PLS 100	731 mm	

B 20.1.1.3

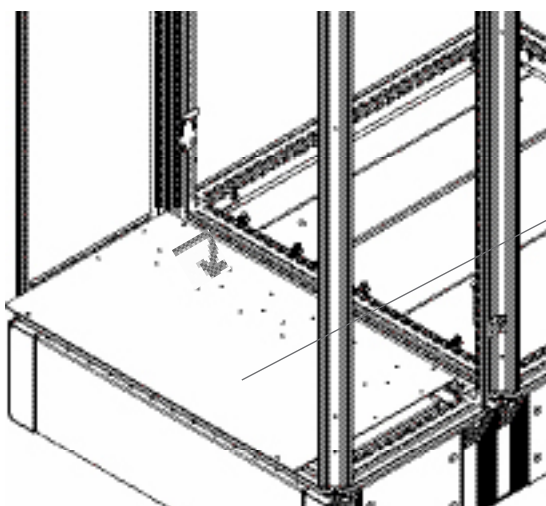

Bodenbereich
In bottom area

Rückbereich unten
In rear bottom section

9674.196 – 9674.198
9674.036 – 9674.048

B 20.1.1.3

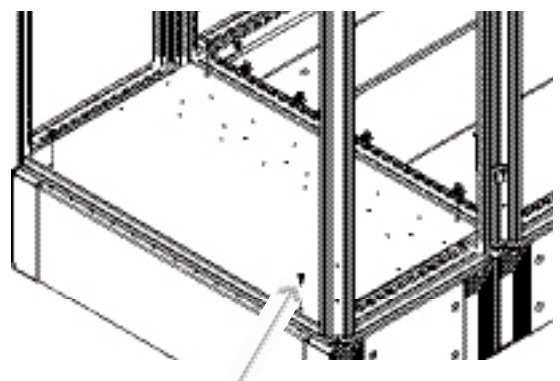

		T 25	5 Nm

Сборка панели секционной перемычки

B 20.1.2.1

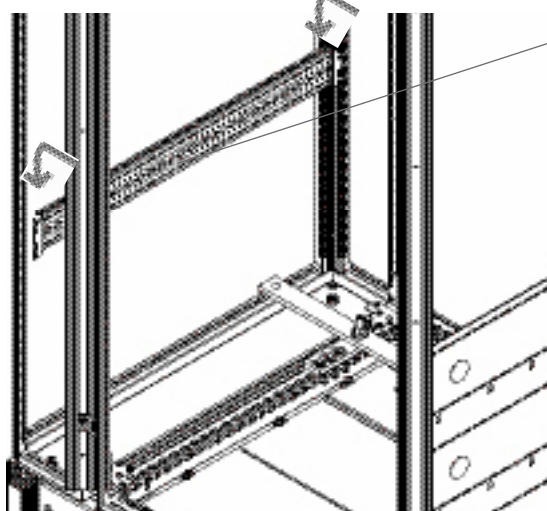

9674.196
9674.198
9674.036
9674.038
9674.046
9674.048

B 20.1.2.2

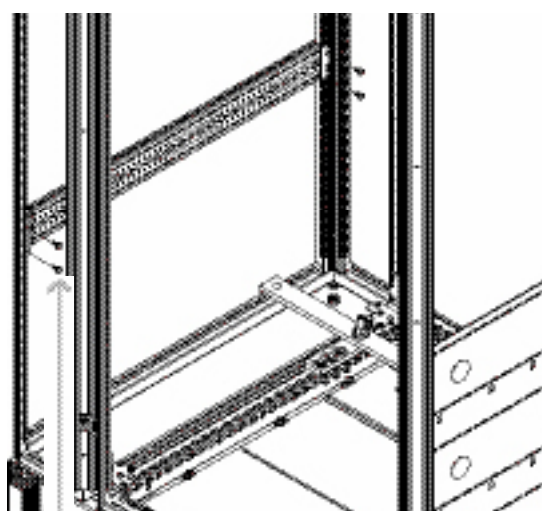

			
		T 25	5 Nm

B 20.1.2.3

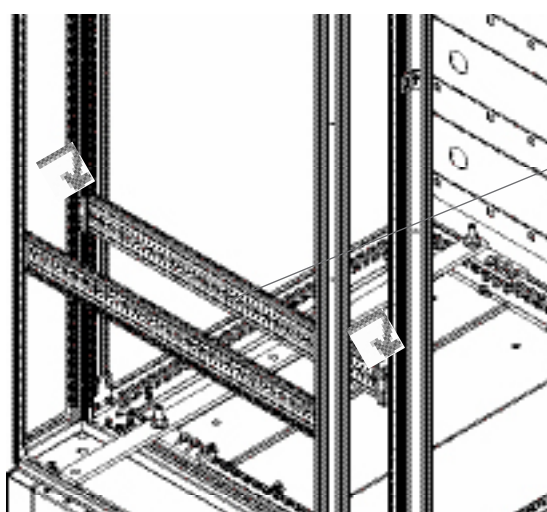

9674.196
9674.198
9674.036
9674.038
9674.046
9674.048

B 20.1.2.4

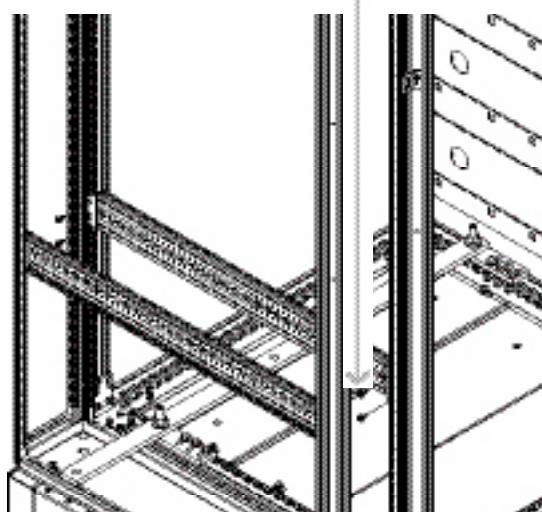

Сборка панели секционной переключки

B 20.2.1
Maxi-PLS
1600
2000

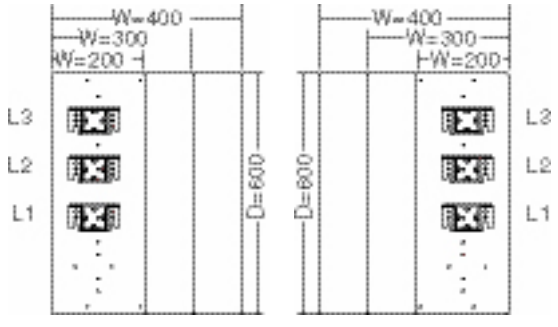

B 20.2.2
Maxi-PLS
1600
2000

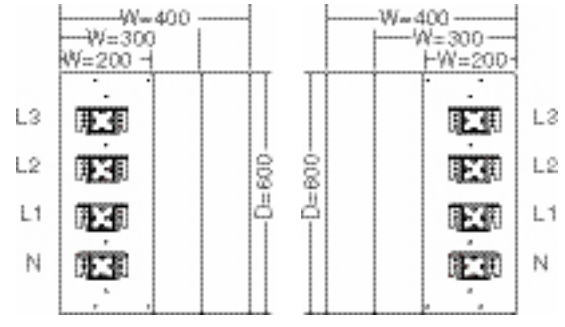

B 20.2.3
Maxi-PLS
1600
2000

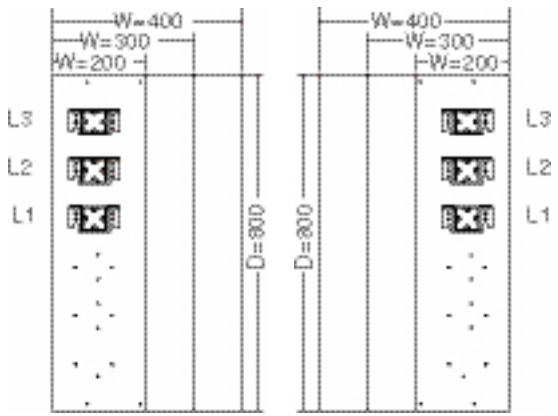

B 20.2.4
Maxi-PLS
1600
2000

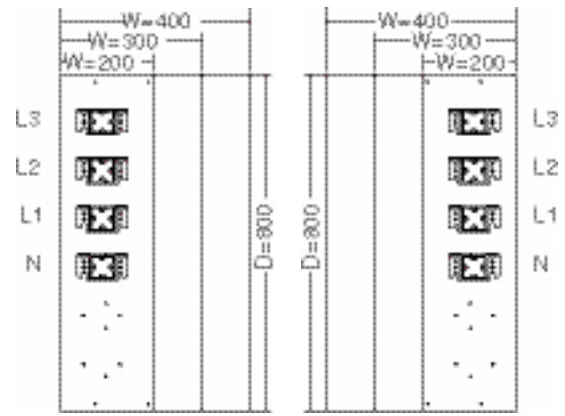

B 20.2.5
Maxi-PLS
3200

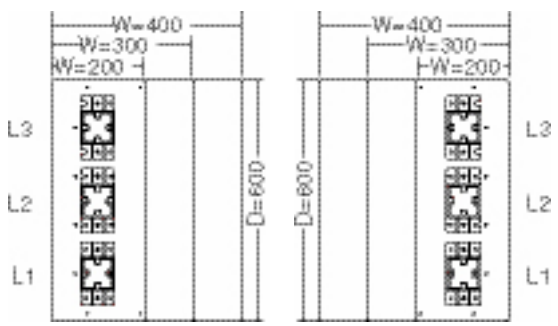

B 20.2.6
Maxi-PLS
3200

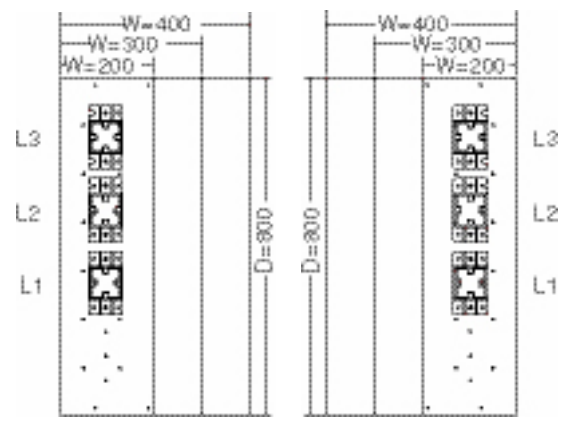

B 20.2.7
Maxi-PLS
3200

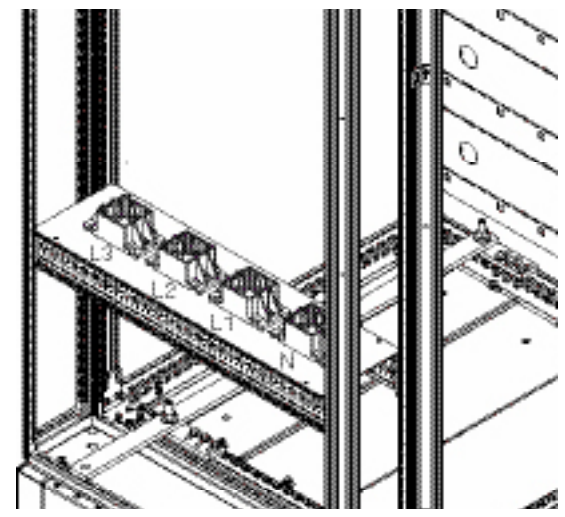
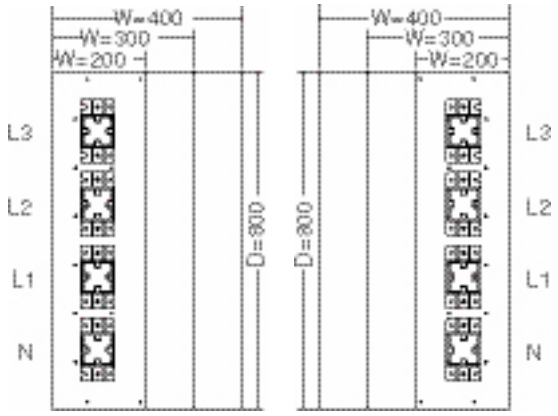

Сборка панели секционной переключки

B 20.2.8

Flat-PLS
60

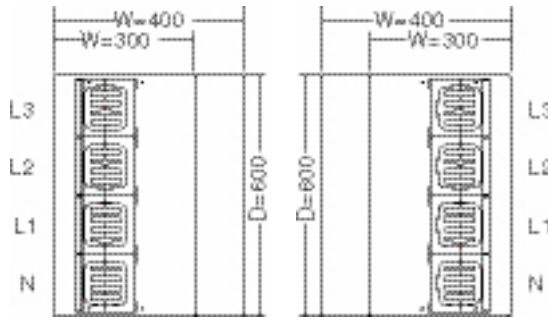

B 20.2.9

Flat-PLS
60

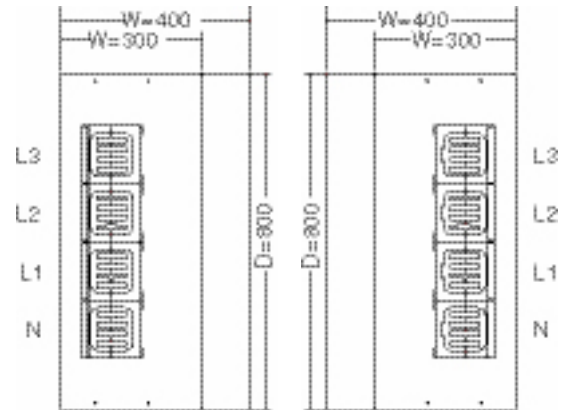

B 20.2.10

Flat-PLS
100

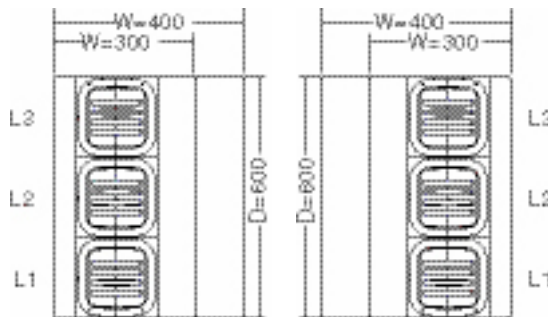

B 20.2.11

Flat-PLS
100

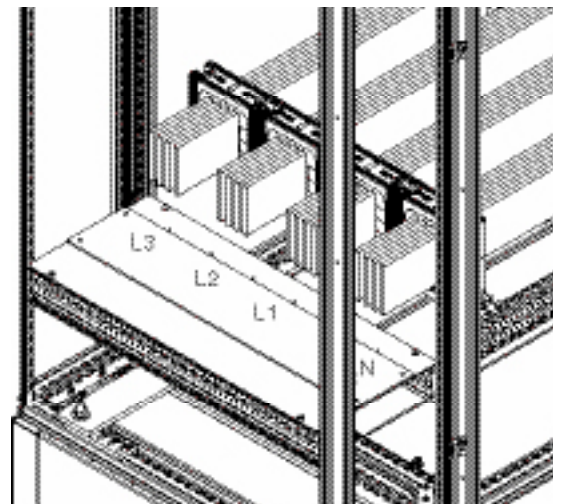
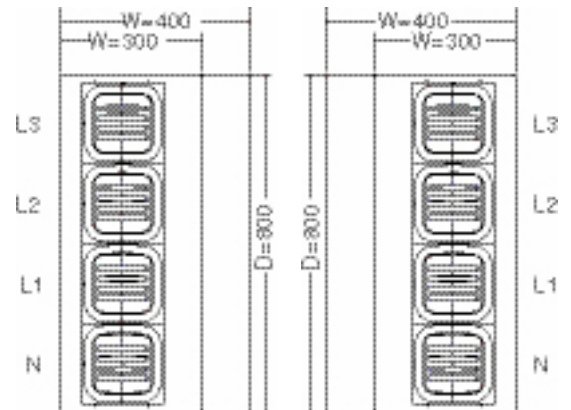

Сборка панели секционной перемычки

B 20.3.1.1

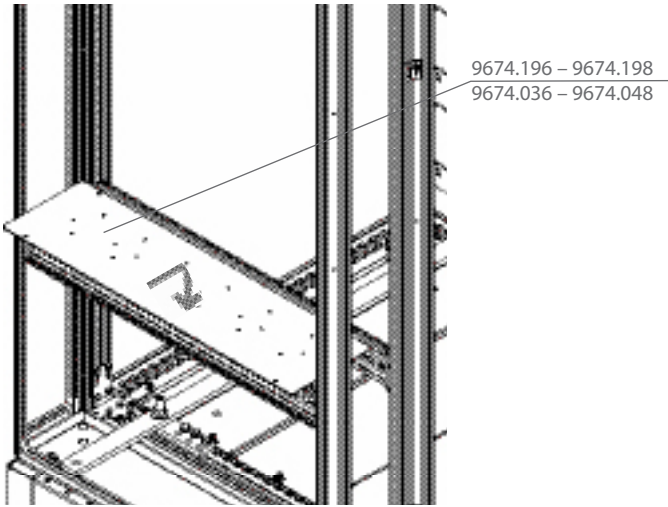

B 20.3.1.2

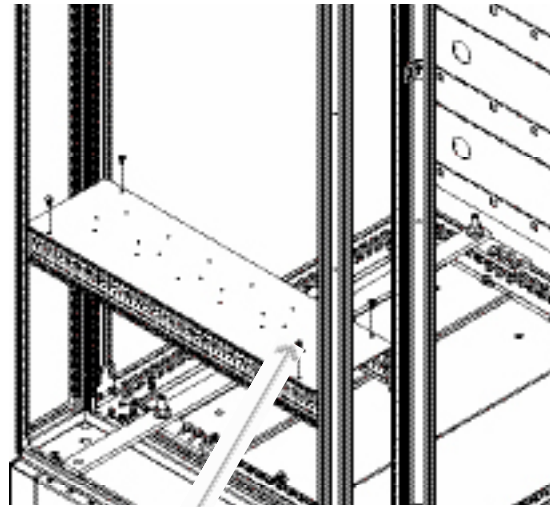

B 20.4.1

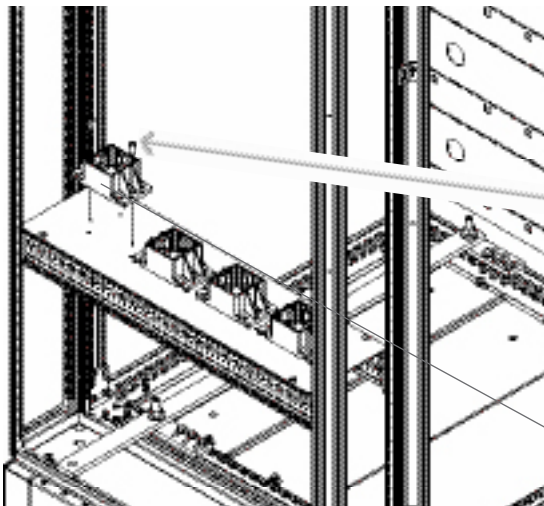

9649.010
9659.010

		T 25	5 Nm

		T 25	5 Nm

B 20.4.2.1

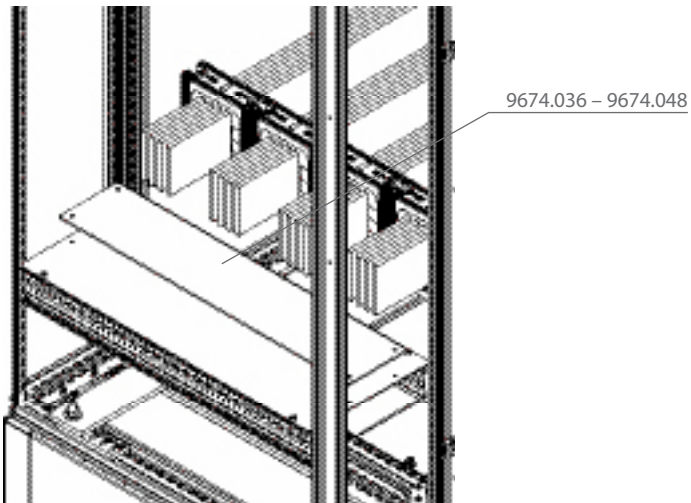

B 20.4.2.2

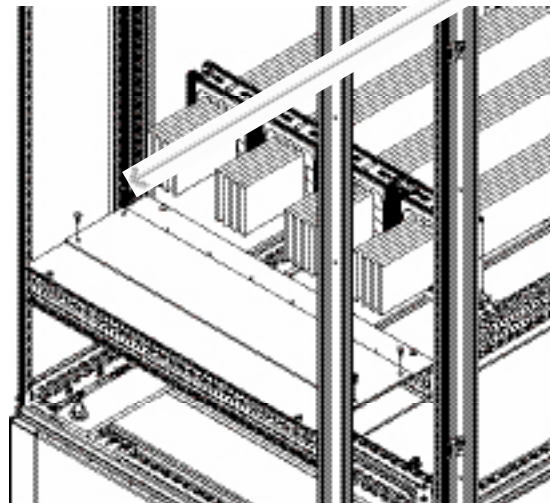

		T 25	5 Nm

Установка профилей под/над выключателем в секционной панели

B 21.1.1

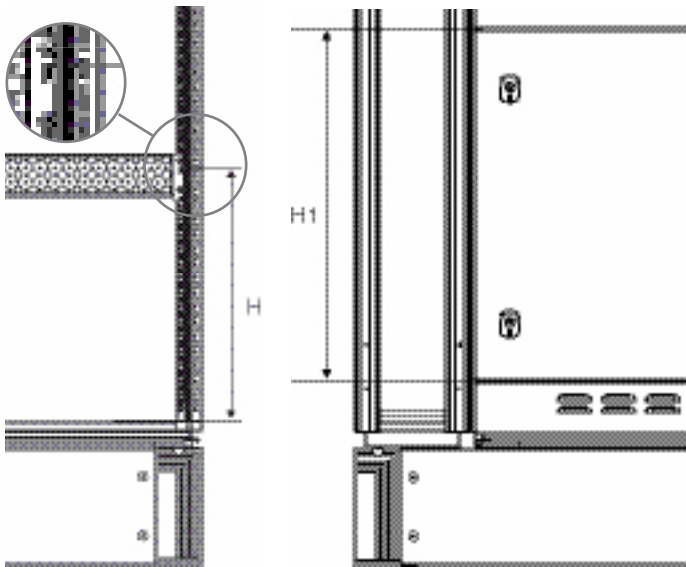

H1	H		
	direkt unter Schalter		
	directly below the circuit breaker		
600 mm	800 mm	1000 mm	
Maxi-PLS 1600/2000	431 mm	631 mm	831 mm
Maxi-PLS 3200	431 mm	631 mm	831 mm
Flat-PLS 60	331 mm	531 mm	731 mm
Flat-PLS 100	331 mm	531 mm	731 mm

B 21.1.2

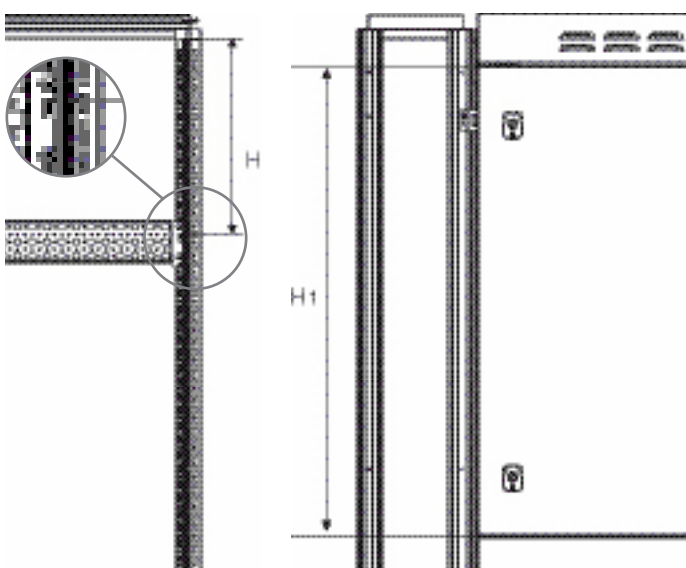

H1	H		
	direkt über Schalter		
	directly above the circuit breaker		
600 mm	800 mm	1000 mm	
Maxi-PLS 1600/2000	331 mm	531 mm	731 mm
Maxi-PLS 3200	331 mm	531 mm	731 mm
Flat-PLS 60	306 mm	506 mm	706 mm
Flat-PLS 100	306 mm	506 mm	706 mm



B 21.2.1

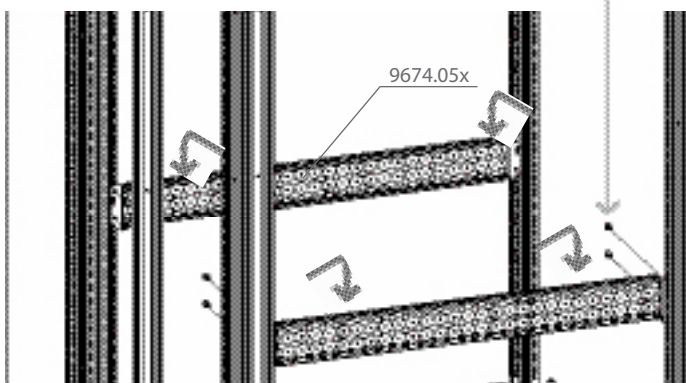

B 21.2.2

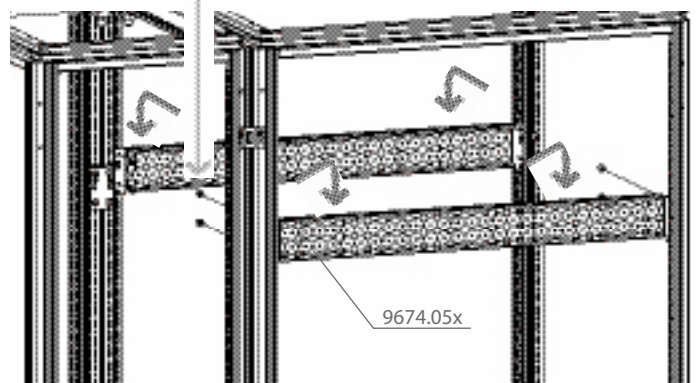

Сборка панели секционной перемычки с Maxi-PLS

B 22.1.1
Maxi-PLS
1600
2000

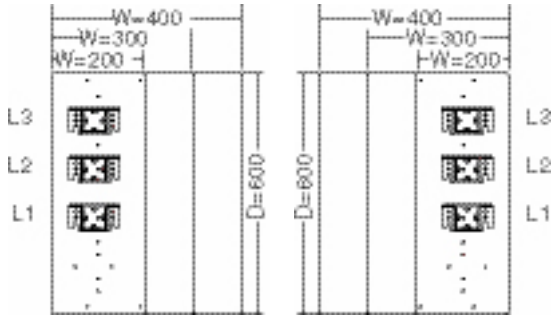

B 22.1.2
Maxi-PLS
1600
2000

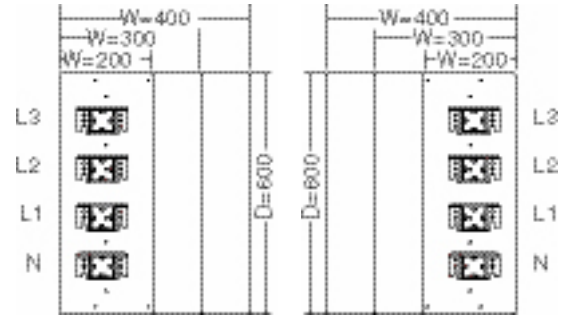

B 22.1.3
Maxi-PLS
1600
2000

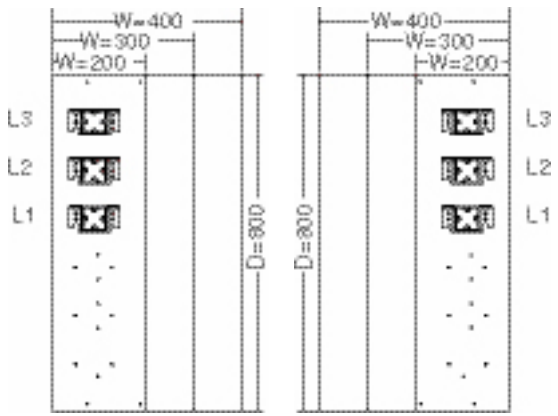

B 22.1.4
Maxi-PLS
1600
2000

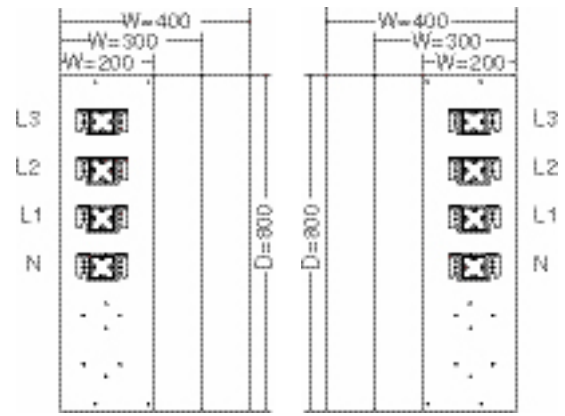

B 22.1.5
Maxi-PLS
3200

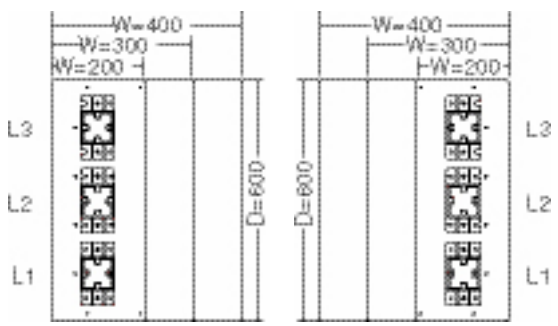

B 22.1.6
Maxi-PLS
3200

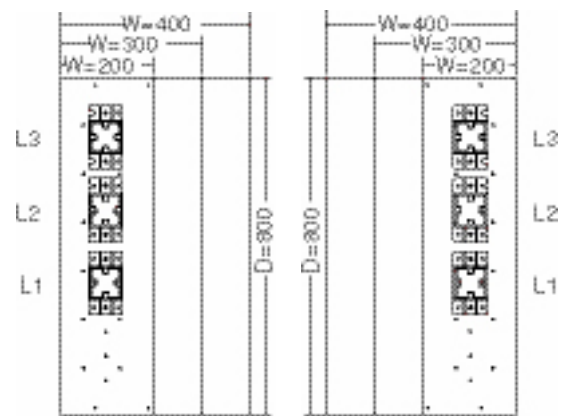

B 22.1.7
Maxi-PLS
3200

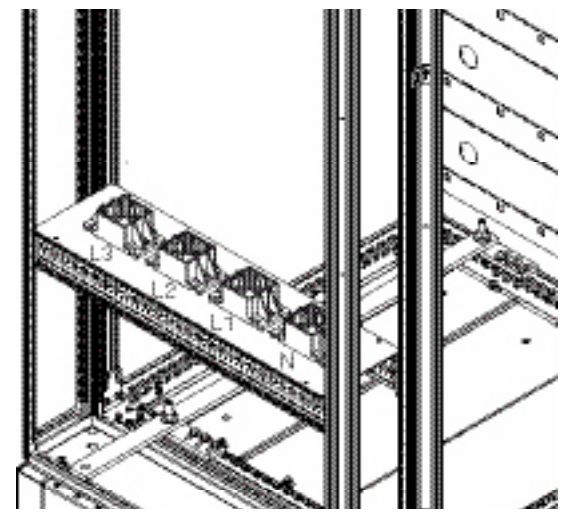
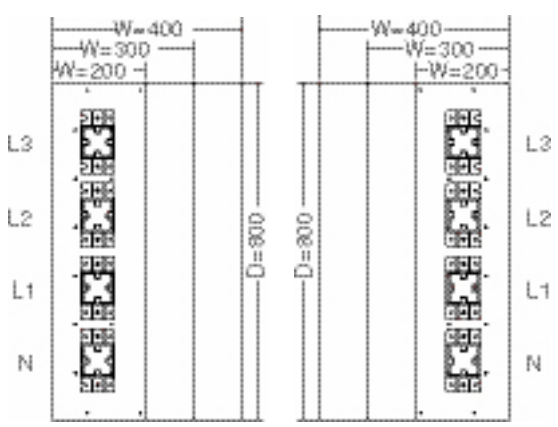

Сборка панели секционной переключки с Flat-PLS

B 22.1.8

Flat-PLS
60

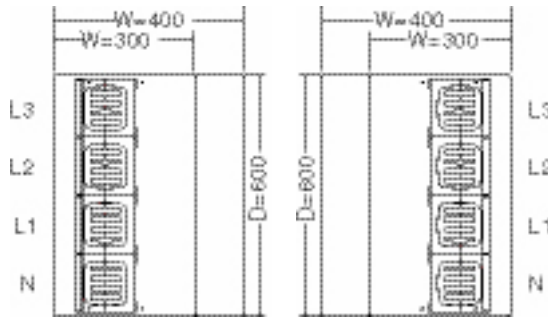

B 22.1.9

Flat-PLS
60

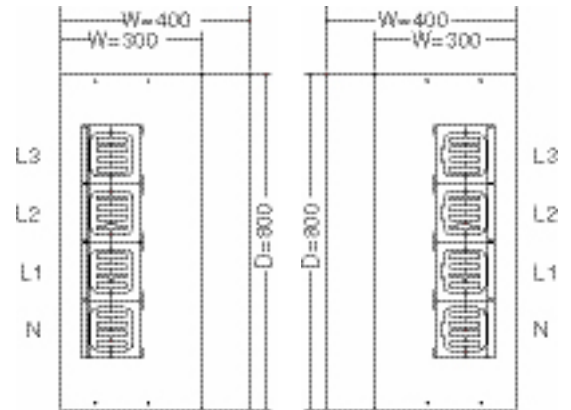

B 22.1.10

Flat-PLS
100

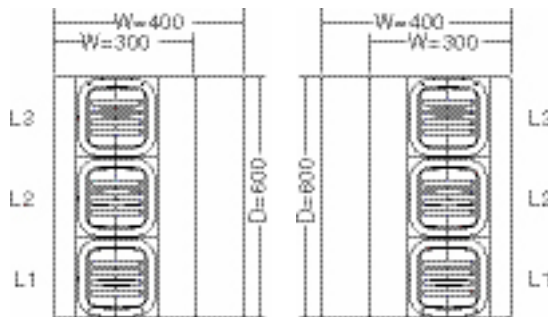

B 22.1.1

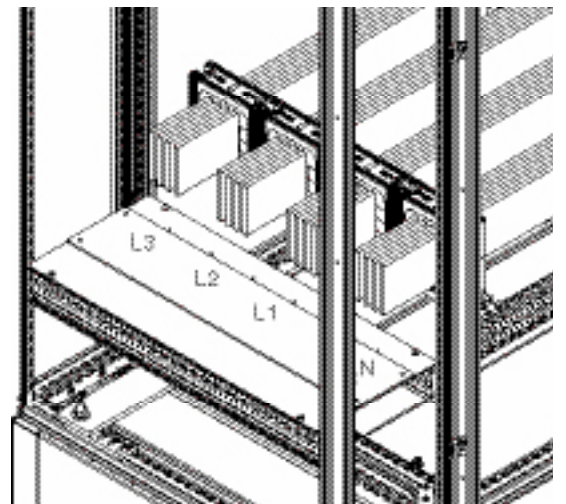
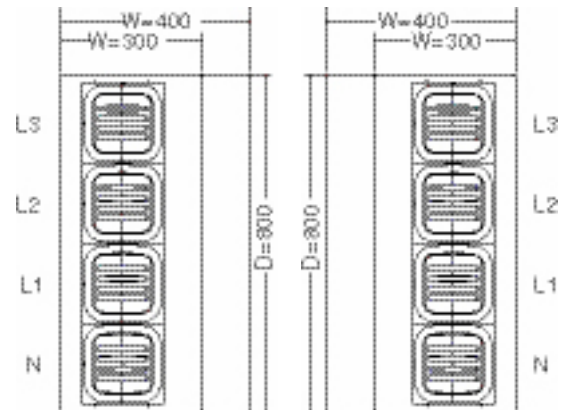

Flat-PLS
100

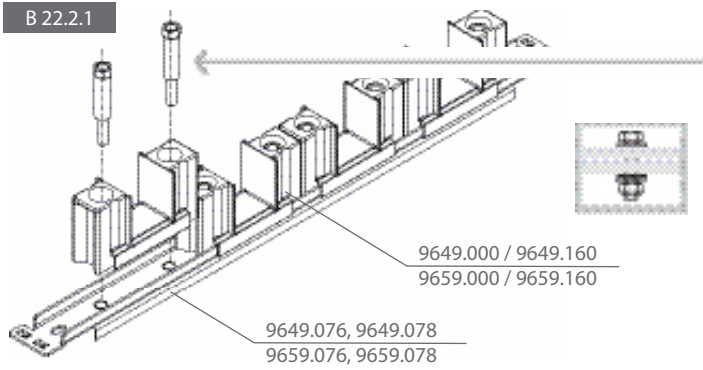

Сборка панели секционной перемишки с Maxi-PLS

B 22.2.1



	1600	SW 13	20 Nm
	2000	SW 13	20 Nm
	3200	SW 17	25 Nm

H	H1	H2	H3	H4	H5
1800mm	323mm	250mm	225mm	200mm	- mm
2000mm	323mm	275mm	300mm	300mm	- mm
2200mm	323mm	250mm	275mm	275mm	275mm

B 22.2.1.2

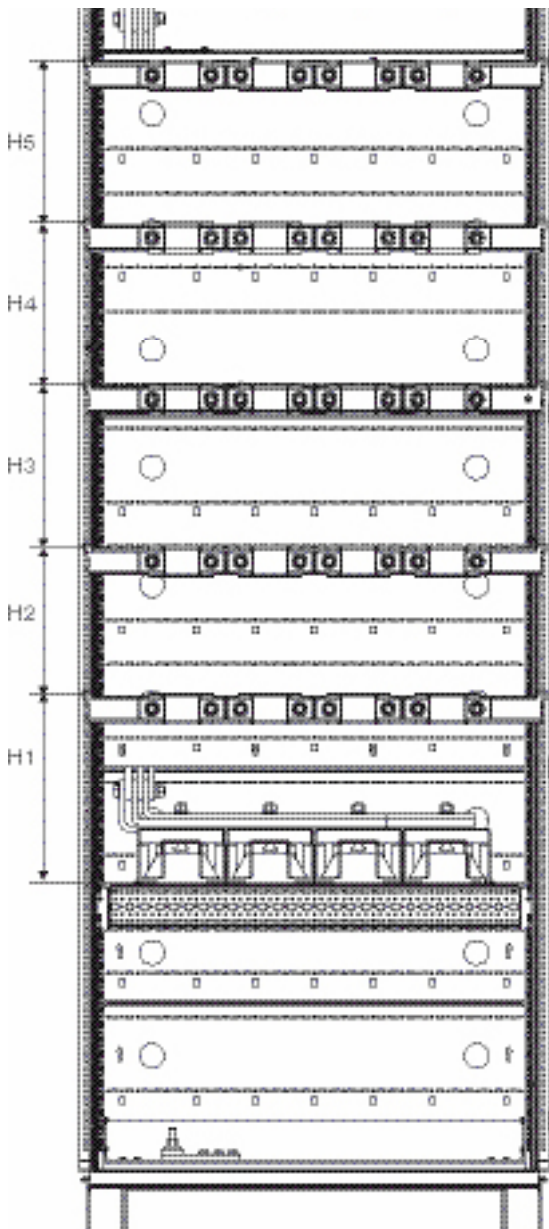

B 22.2.1.3

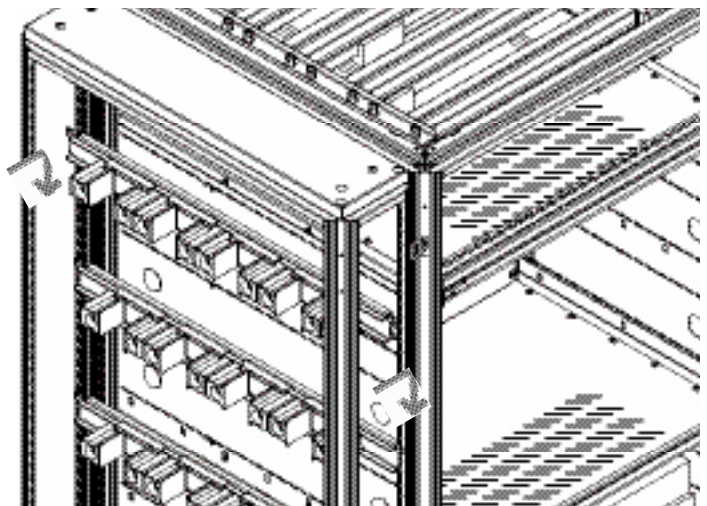

B 22.2.1.4

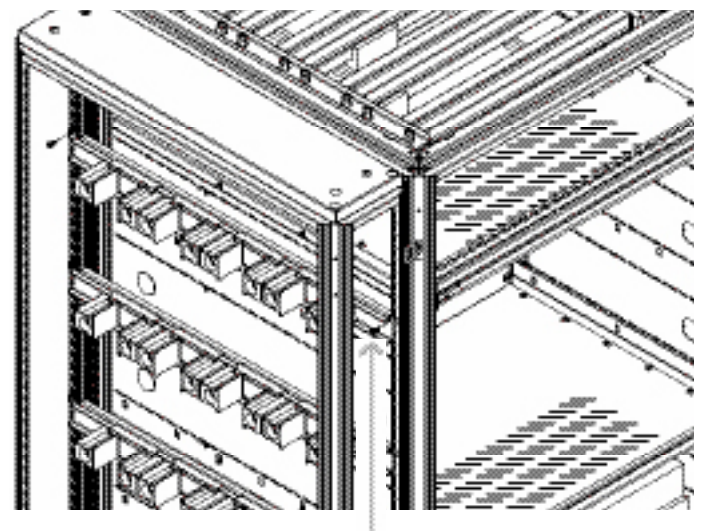

			T 25	5 Nm
--	--	--	------	------

Сборка панели секционной перемишки с Maxi-PLS

B 22.2.2.1

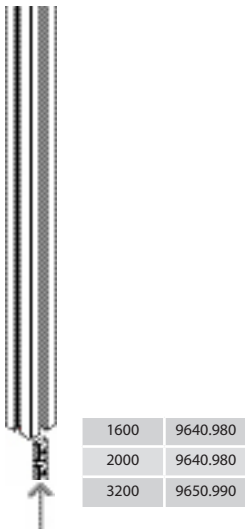

B 22.2.2.2

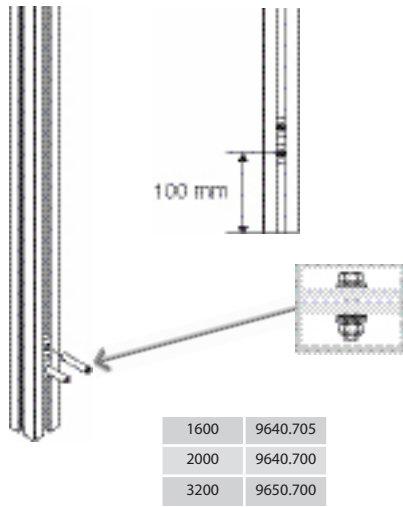

B 22.2.2.3

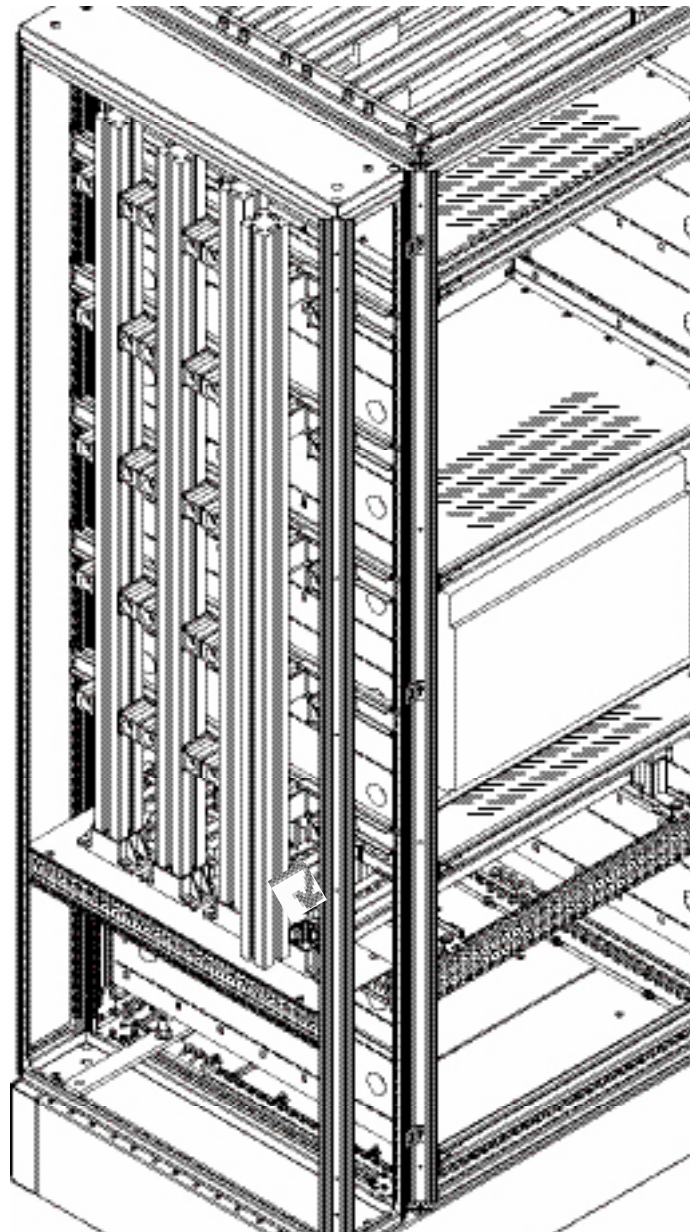

B 22.2.2.4

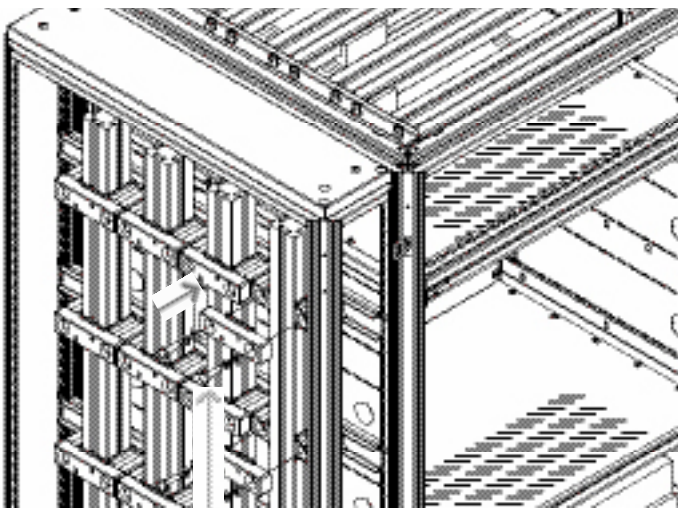

	1600	SW 12/13	15 Nm
	2000	SW 12/13	15 Nm
	3200	SW 16/17	20 Nm

B 22.2.2.5

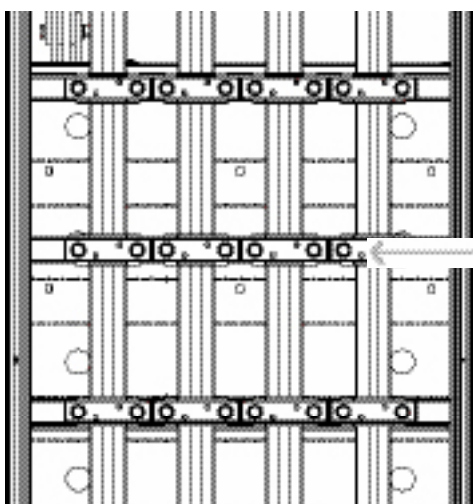

	1600	Gr./Size 2	0,8 Nm
	2000	Gr./Size 2	0,8 Nm
	3200	Gr./Size 2	0,8 Nm

Сборка панели секционной перемычки с Flat-PLS

Сборка панели секционной перемычки Assembling the coupling set assembly kit

B 22.3.1.1

Flat PLS 100

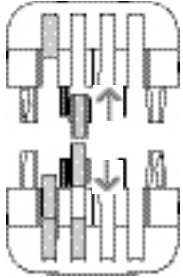

Flat PLS 60



9676.008



	2 x	3 x	4 x
	9676.008	9676.008	9676.008
Flat PLS 60	4	2	-
Flat PLS 100	6	3	-

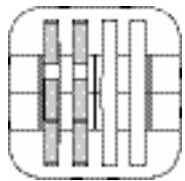

Flat PLS 100
2 x Cu

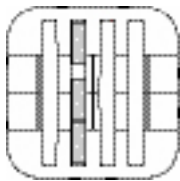

Flat PLS 100
3 x Cu

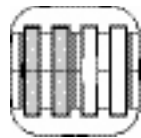

Flat PLS 60
2 x Cu

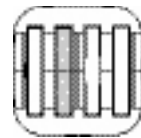

Flat PLS 60
3 x Cu

B 22.3.1.2

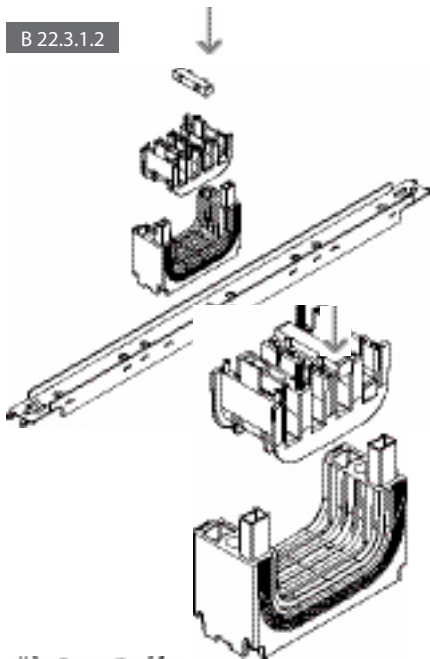

9676.007



	9676.007		
Flat-PLS 60	40 x 10	2	4 x
	50 x 10	1	4 x
	60 x 10	-	-
Flat-PLS 100	80 x 10	2	4 x
	100 x 10	-	-



Flat PLS 100
80 x 10



Flat PLS 60
40 x 10

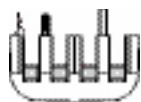

Flat PLS 60
50 x 10

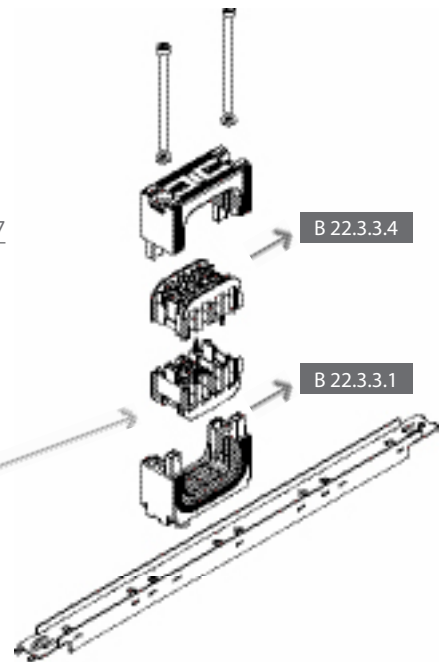

B 22.3.3.4

B 22.3.3.1

Сборка панели секционной перемишки с Flat-PLS

B 22.3.2.1

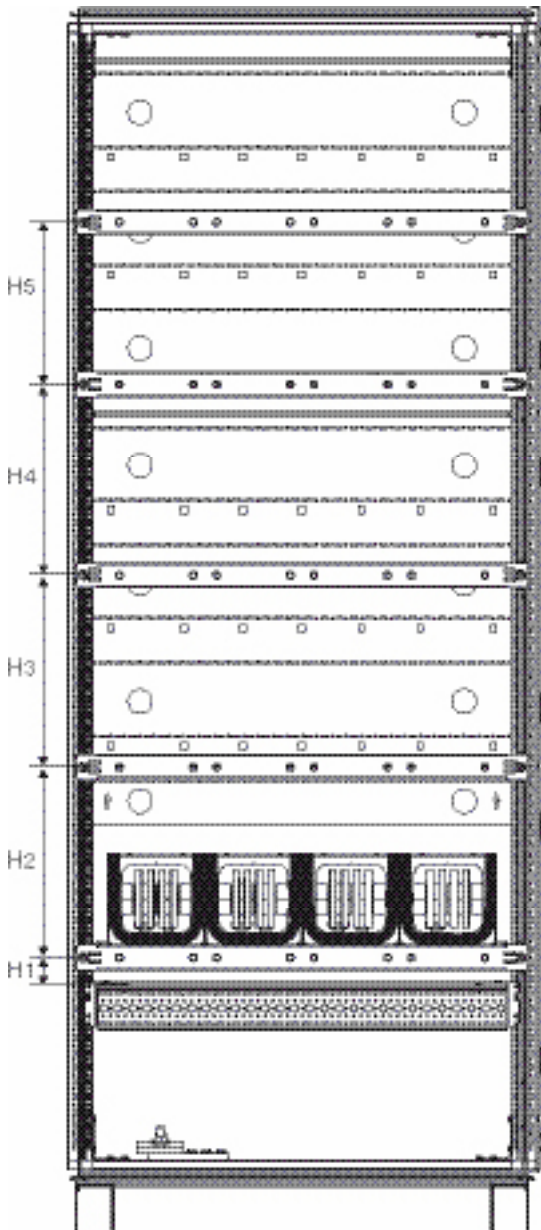

H	H1	H2	H3	H4	H5
2000mm	46mm	325mm	325mm	325mm	275mm
2200mm	46mm	350mm	375mm	375mm	350mm

B 22.3.2.2

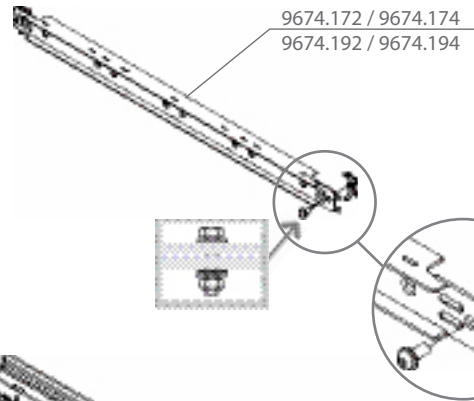

B 22.3.2.3

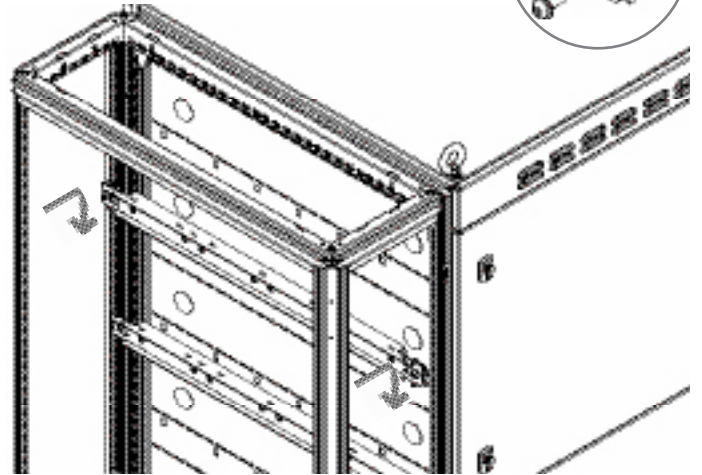

B 22.3.2.4



B 22.3.2.5

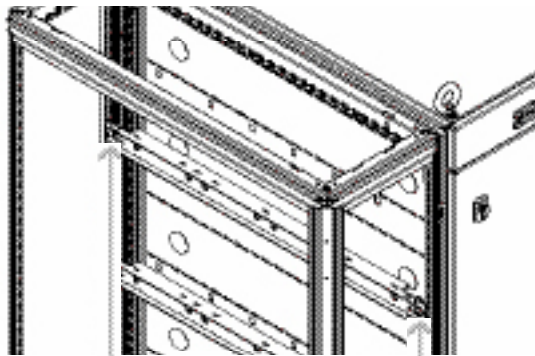

B 22.3.3.1

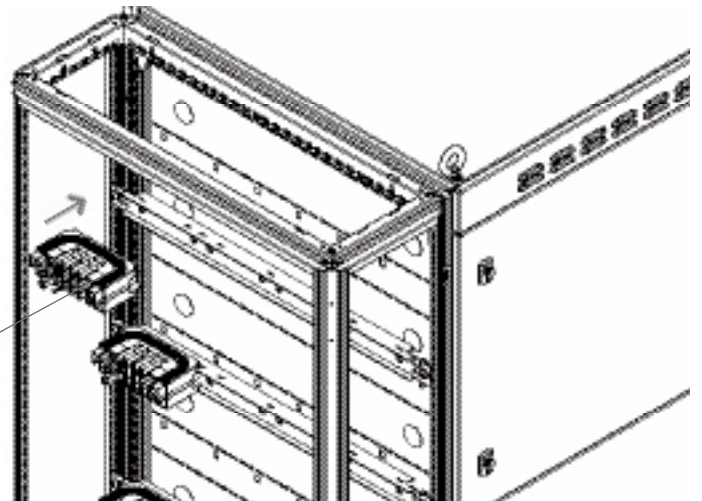

Flat-PLS 60	SW 6	20 Nm
Flat-PLS 100	SW 6	20 Nm

9676.002
9676.004
9676.020
9676.021

Сборка панели секционной перемички Flat-PLS

Сборка панели секционной перемички Assembling the coupling set assembly kit

B 22.3.3.2

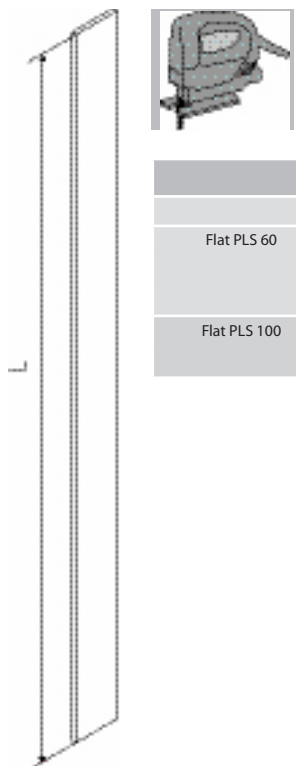

		H = 2000mm	H = 2200mm
		L	L
Flat PLS 60	40 x 10	1510mm	1710mm
	50 x 10	1510mm	1710mm
	60 x 10	1510mm	1710mm
Flat PLS 100	80 x 10	1470mm	1670mm
	100 x 10	1470mm	1670mm

B 22.3.3.3

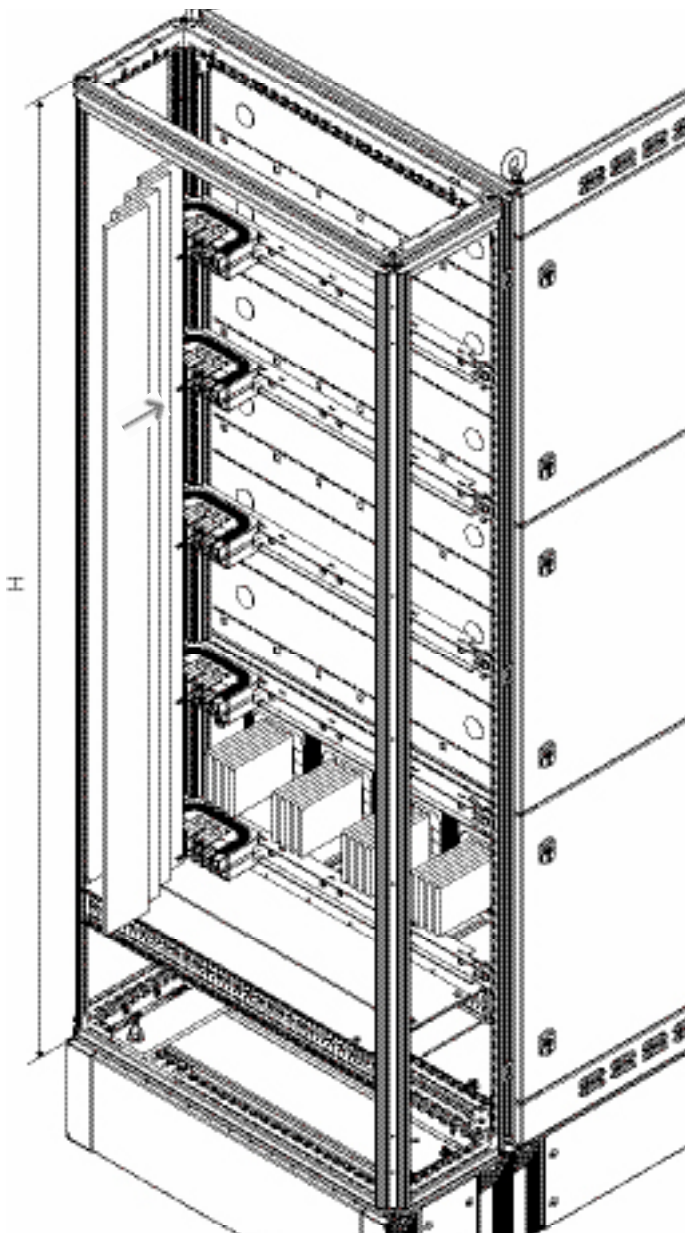

B 22.3.3.4

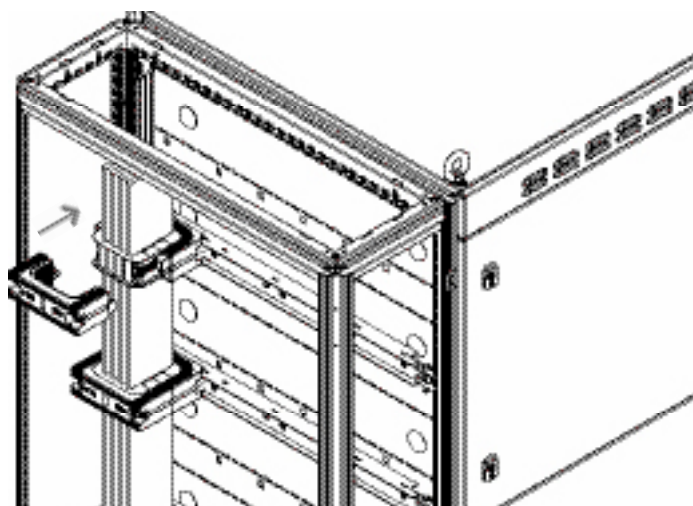

B 22.3.3.5

	Flat-PLS 60	SW 6	8 Nm
	Flat-PLS 100	SW 8	9 Nm

Соединение панели секционной перемычки с Maxi-PLS

В 23.1.1

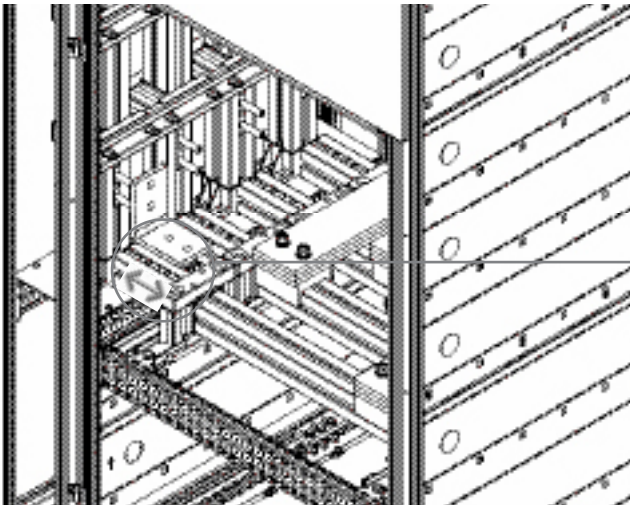

В 23.1.2.1

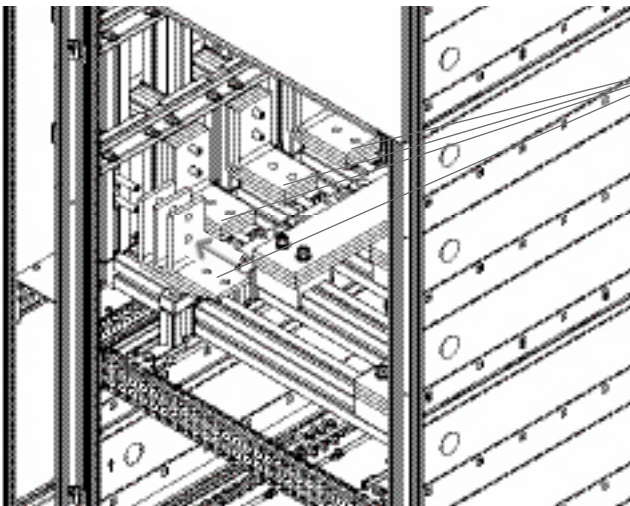

В 23.1.2.2

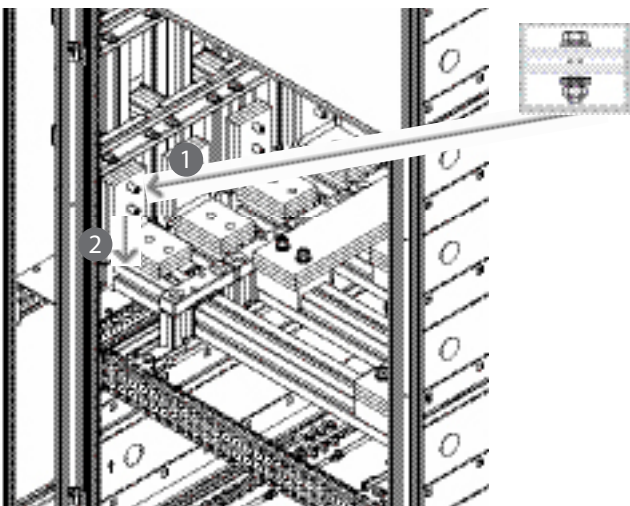

В 23.1.2.3

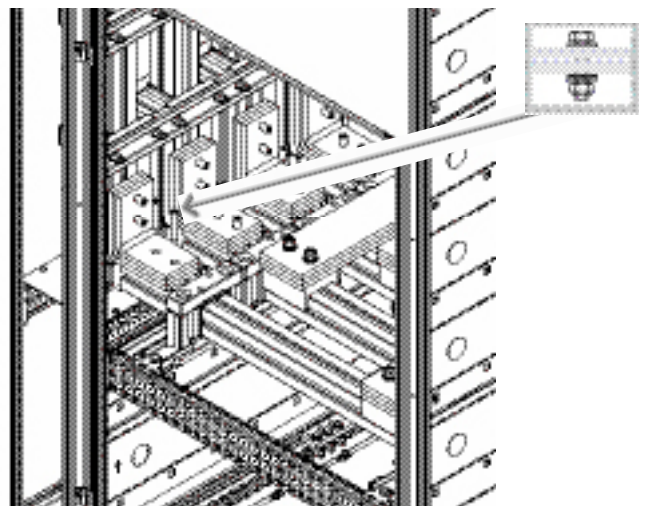

Соединение панели секционной перемычки с Maxi-PLS

B 23.1.2.4

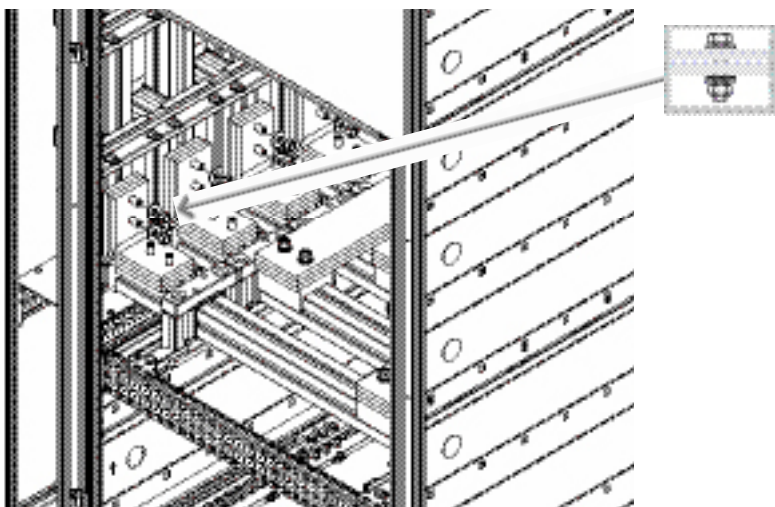

B 23.1.2.5

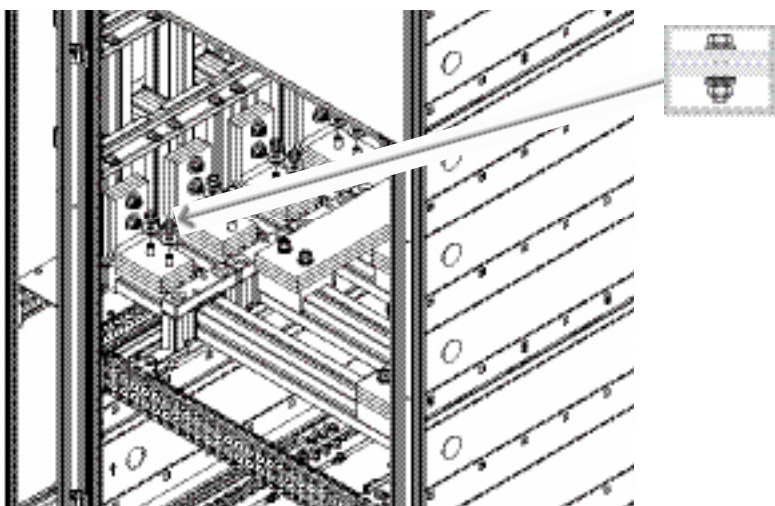

B 23.1.3

2		1600	SW 16/17	20 Nm
		2000	SW 16/17	20 Nm
		3200	SW 18/19	40 Nm
1		1600	SW 5	10 Nm
		2000	SW 5	10 Nm
		3200	SW 6	10 Nm
1		1600	SW 5	10 Nm
		2000	SW 5	10 Nm
		3200	SW 6	10 Nm
2		1600	SW 16/17	20 Nm
		2000	SW 16/17	20 Nm
		3200	SW 18/19	40 Nm

Соединение панели секционной перемычки с Flat-PLS

Сборка панели секционной перемычки Assembling the coupling set assembly kit

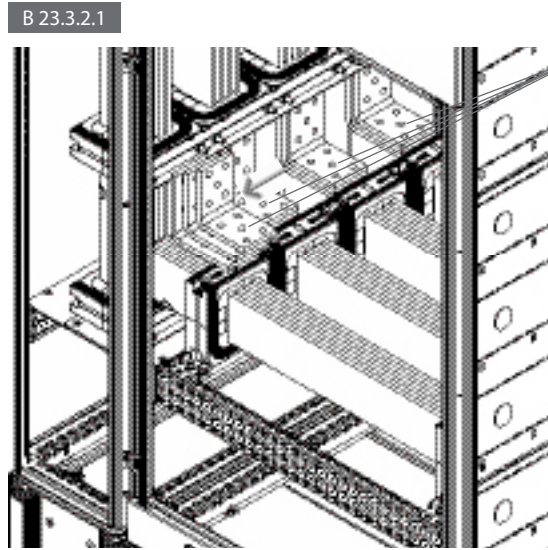
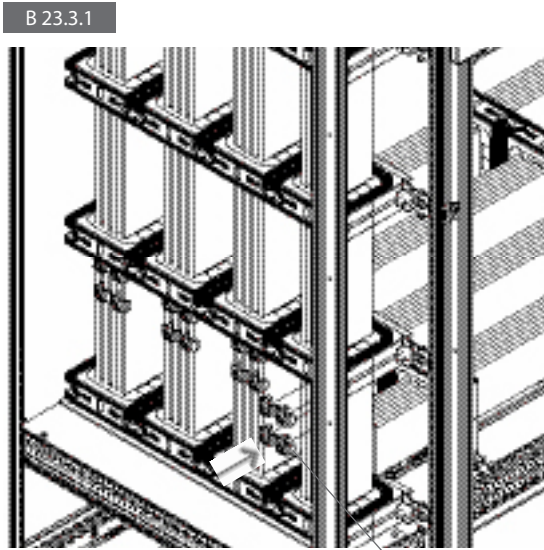

9675.842 – 9675.843
9675.882 – 9675.883
9675.892 – 9675.893

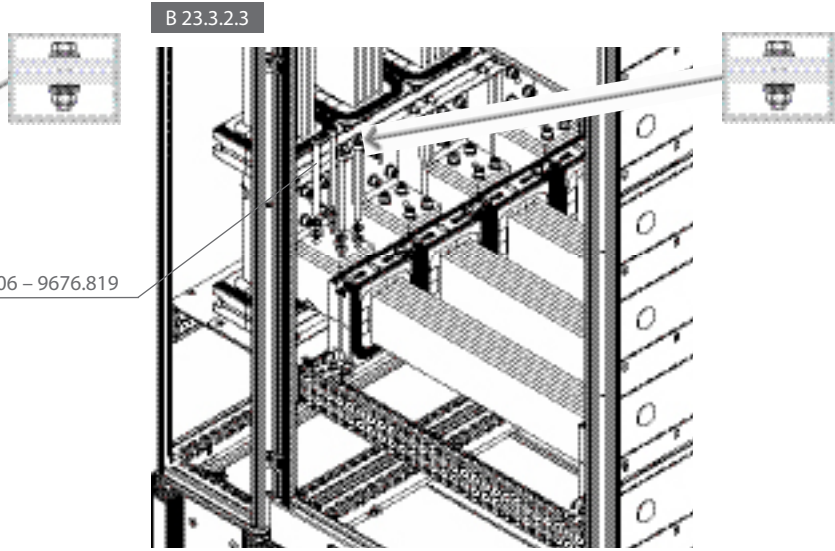
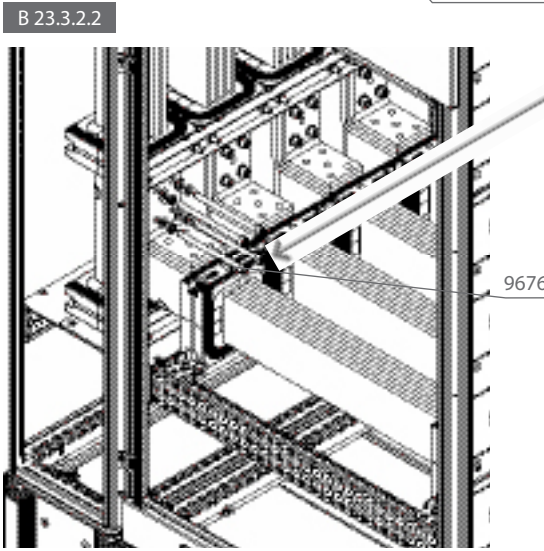

9676.832

9676.806 – 9676.819

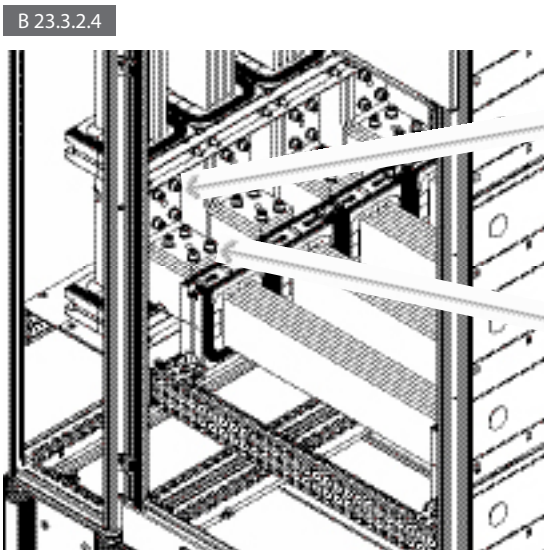

	Flat-PLS 60	SW 8	20 Nm
	Flat-PLS 100	SW 8	20 Nm

	Flat-PLS 60	SW 8	20 Nm
	Flat-PLS 100	SW 8	20 Nm

Соединение панели секционной перемычки с Flat-PLS

B 23.4.1.1

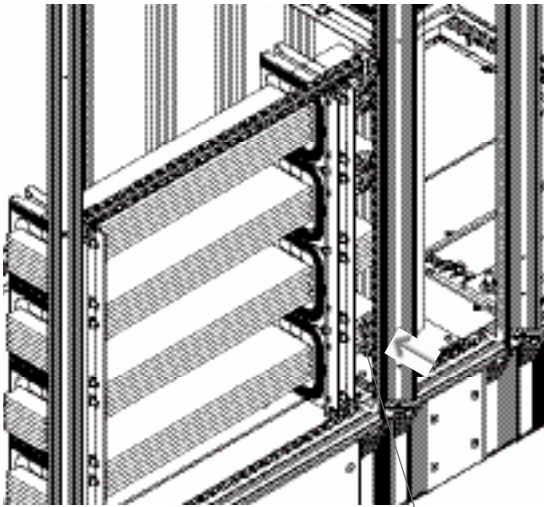

9676.832

B 23.4.1.2

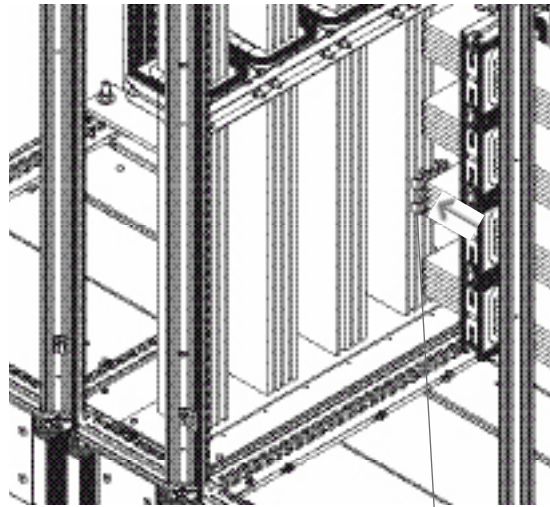

9676.832

B 23.4.2

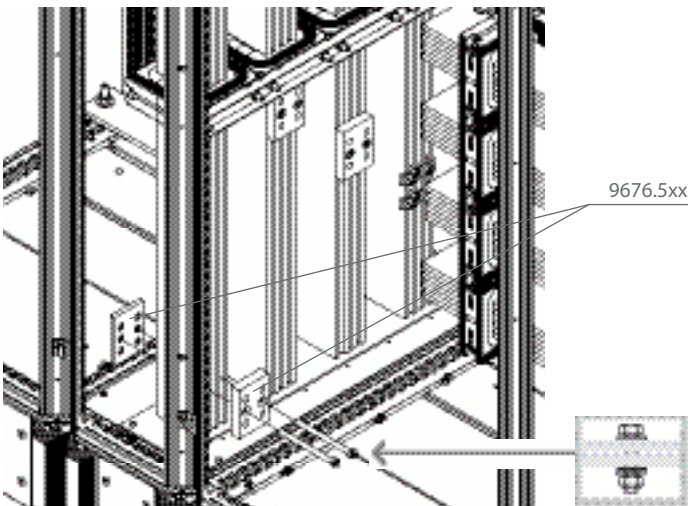

9676.5xx

B 23.4.3.1

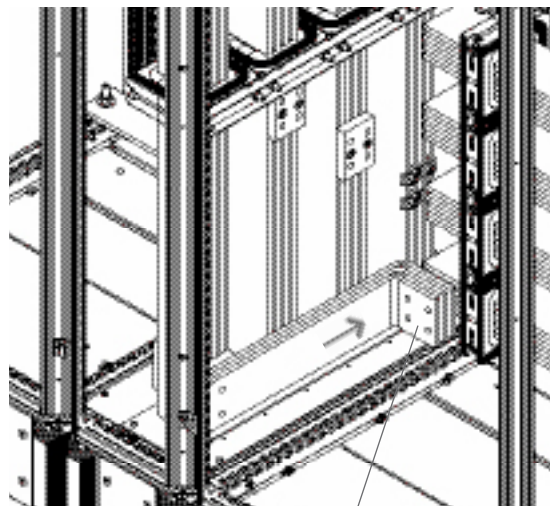

9675.846 – 9675.878
9675.886 – 9675.889
9675.896 – 9675.898

B 23.4.3.2

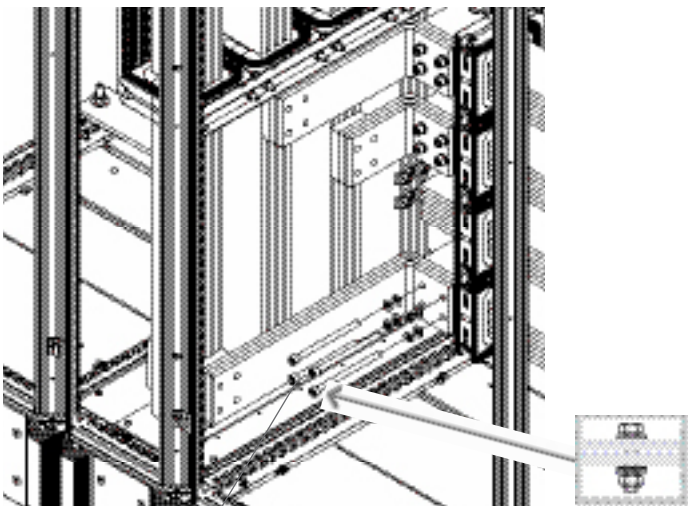

9676.808 – 9676.815

B 23.4.3.3

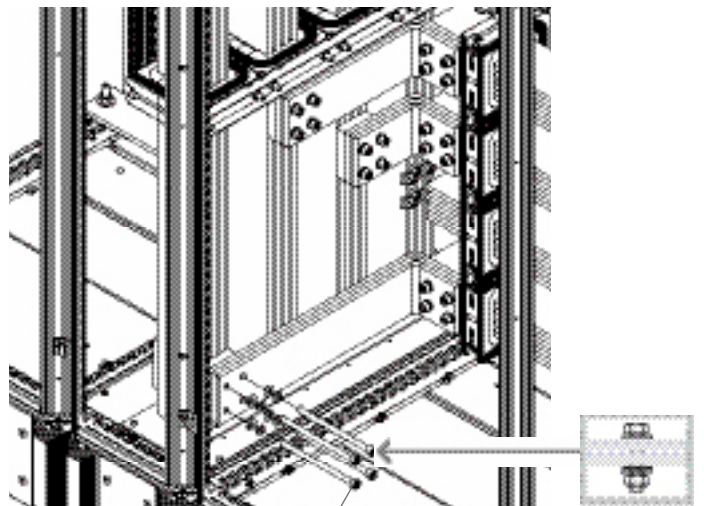

9676.810 – 9676.817

Соединение панели секционной перемычки с Flat-PLS

Сборка панели секционной перемычки Assembling the coupling set assembly kit

B 23.4.4.1

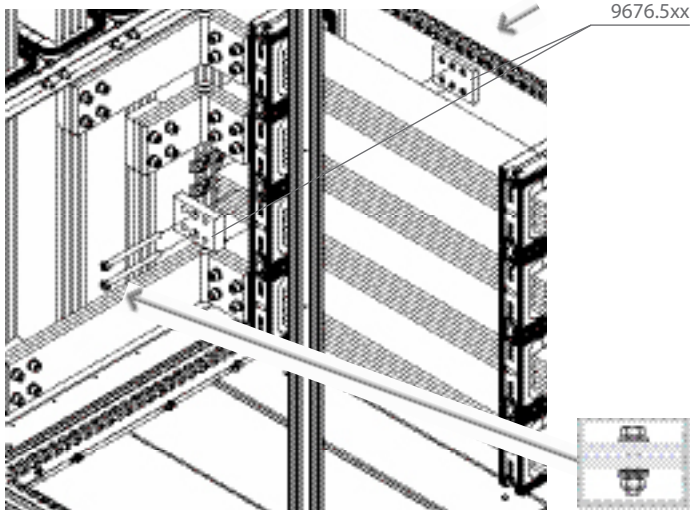

B 23.4.4.2

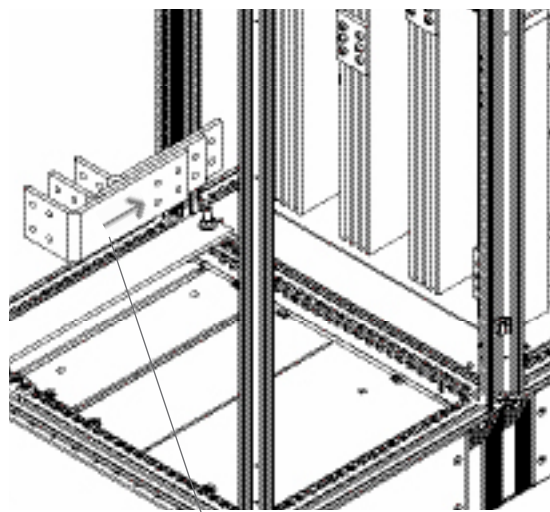

9675.846 - 9675.878
9675.886 - 9675.889
9675.896 - 9675.898

B 23.4.4.3

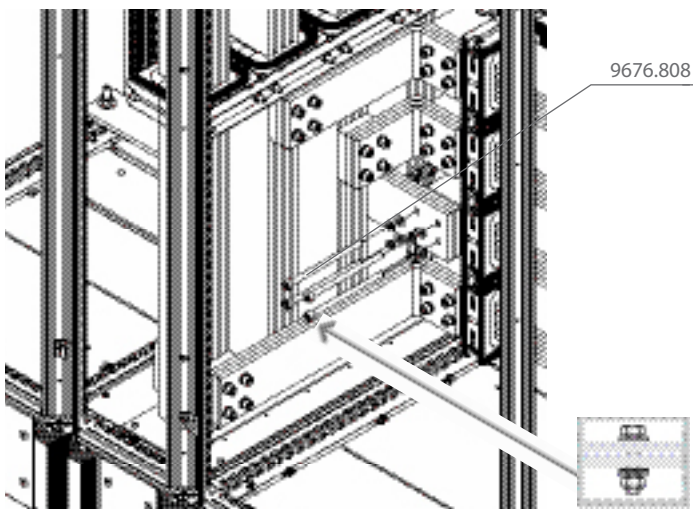



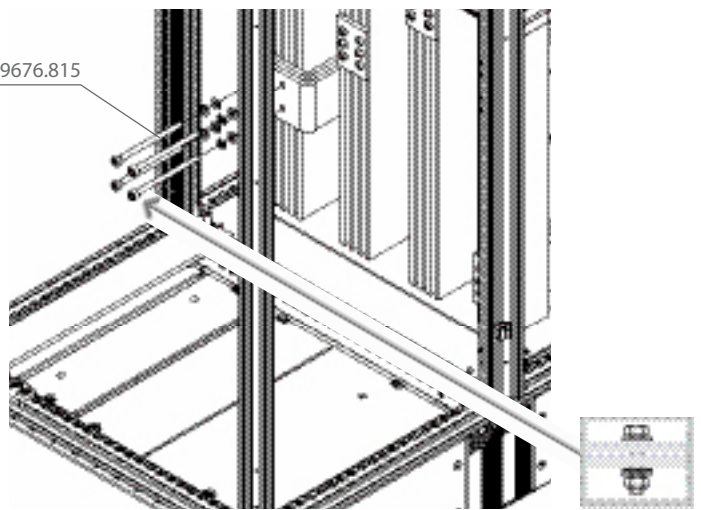

B 23.4.4.4

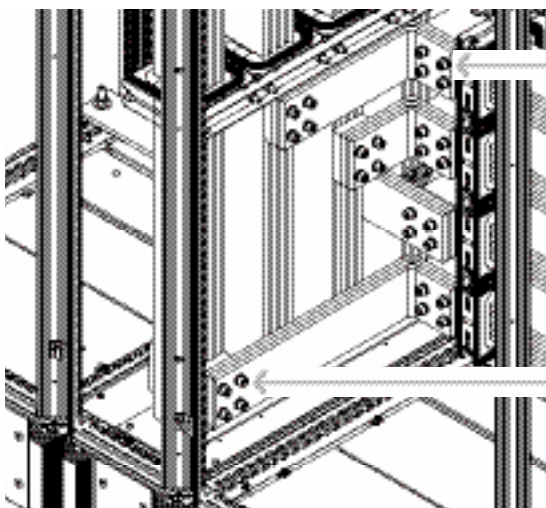

B 23.4.5



	Flat-PLS 60	SW 8	20 Nm
	Flat-PLS 100	SW 8	20 Nm

	Flat-PLS 60	SW 8	20 Nm
	Flat-PLS 100	SW 8	20 Nm

Соединение панели секционной перемычки с Maxi-PLS

В 24.1.1.1

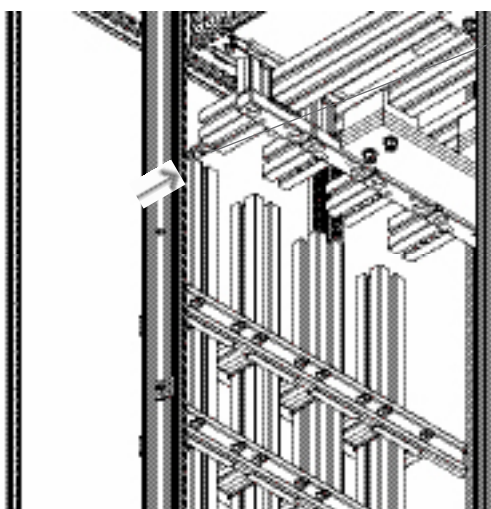

1600	9640.980
2000	9640.980
3200	9650.990

В 24.1.1.2

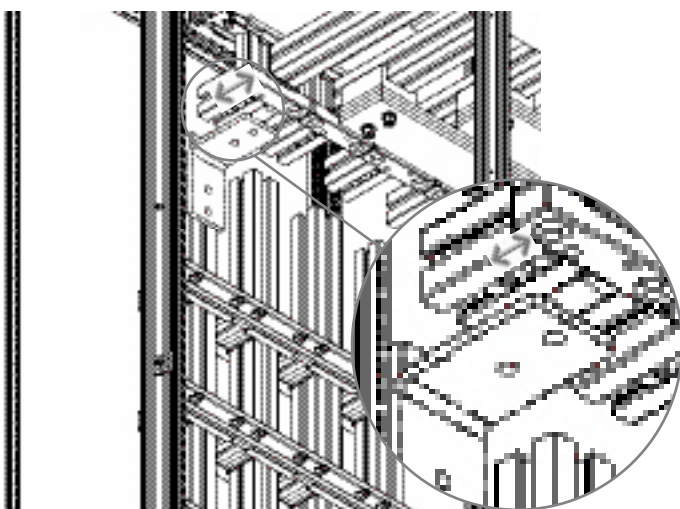

В 24.1.2.1

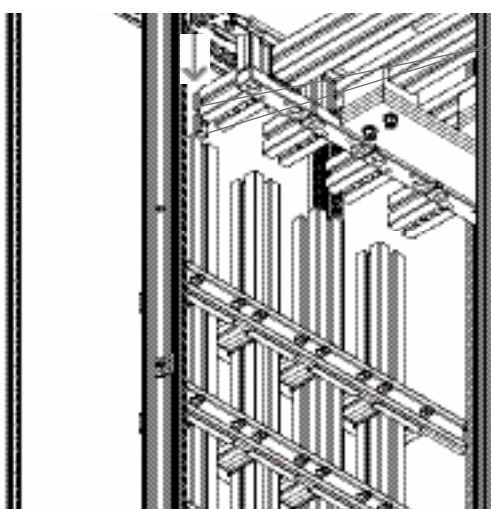

1600	9640.980
2000	9640.980
3200	9650.990

В 24.1.2.2

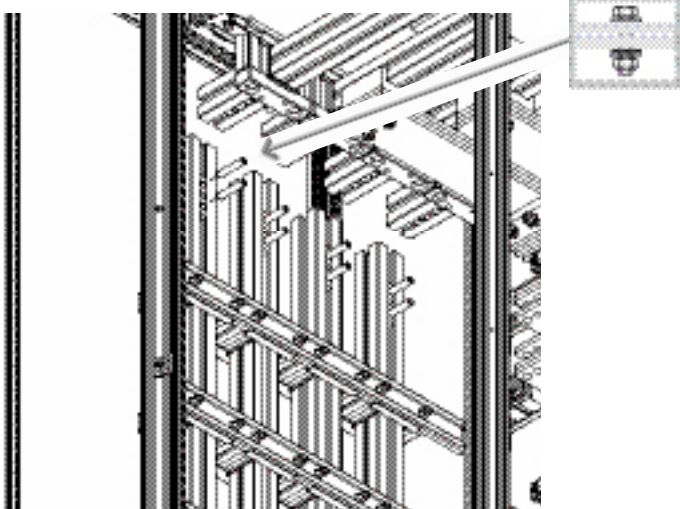

В 24.1.3.1

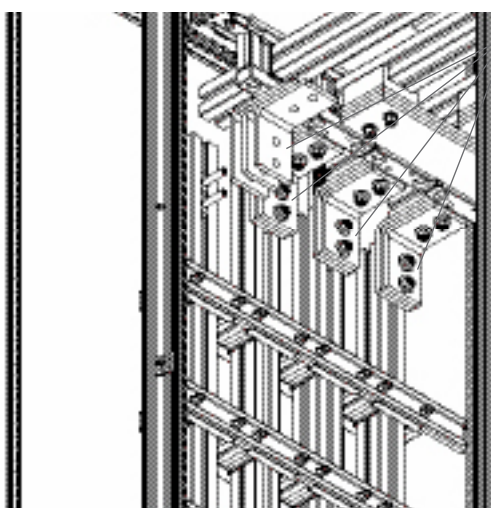

1600	9640.705
2000	9640.700
3200	9650.700

В 24.1.3.2

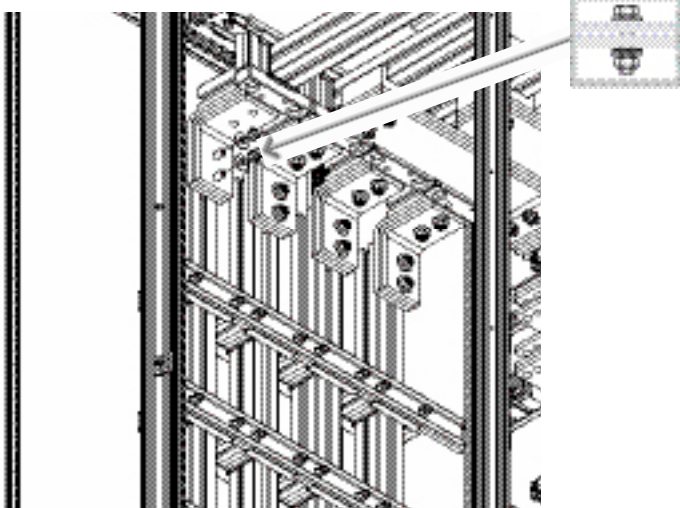

Соединение панели секционной перемычки с Maxi-PLS

B 24.1.3.3

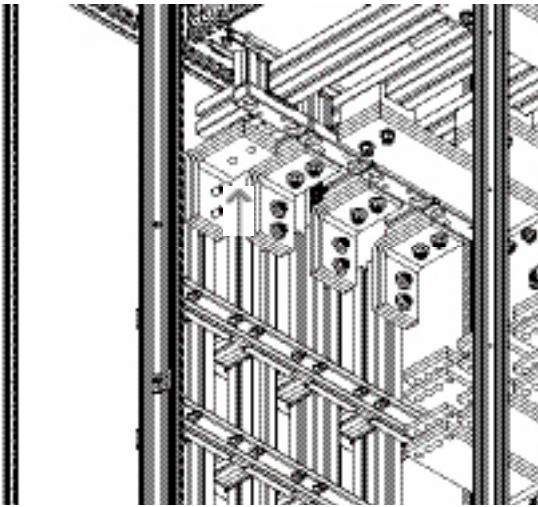

B 24.1.3.4

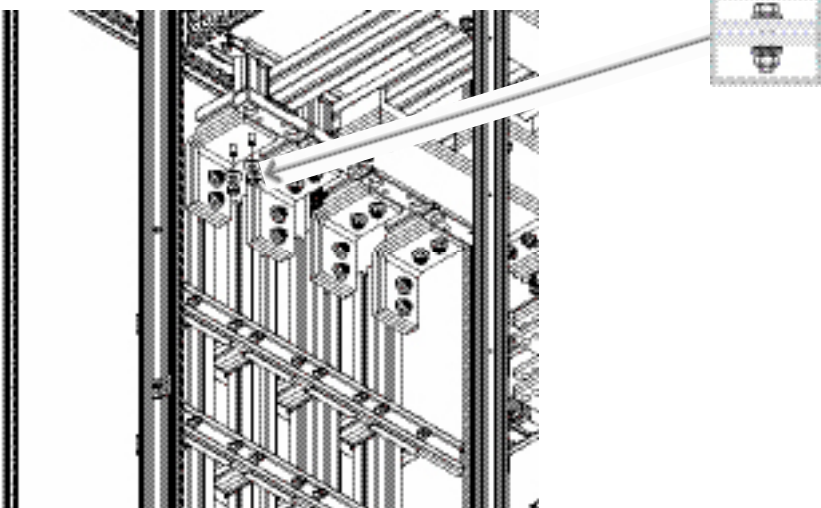

B 24.1.3.5

2	1600	SW 16/17	20 Nm
	2000	SW 16/17	20 Nm
	3200	SW 18/19	40 Nm
1	1600	SW 5	10 Nm
	2000	SW 5	10 Nm
	3200	SW 6	10 Nm
2	1600	SW 16/17	20 Nm
	2000	SW 16/17	20 Nm
	3200	SW 18/19	40 Nm
1	1600	SW 5	10 Nm
	2000	SW 5	10 Nm
	3200	SW 6	10 Nm

Соединение панели секционной перемычки с Maxi-PLS

В 24.2.1.1

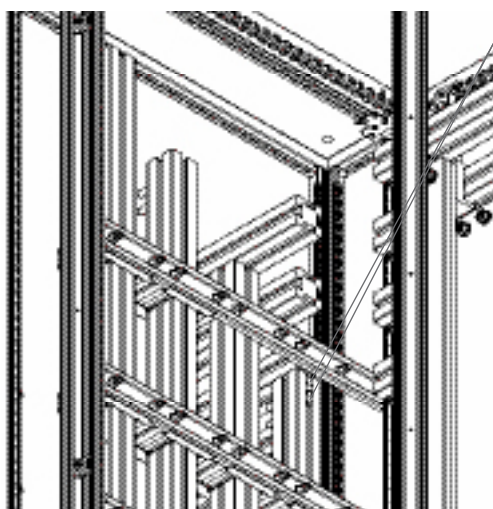

1600	9640.980
2000	9640.980
3200	9650.990

В 24.2.1.2

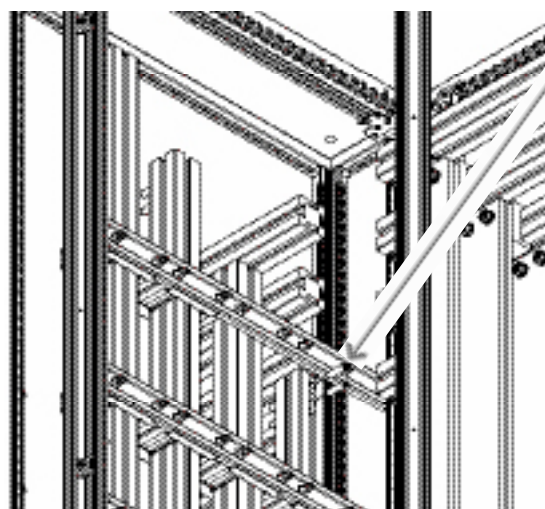

В 24.2.1.3

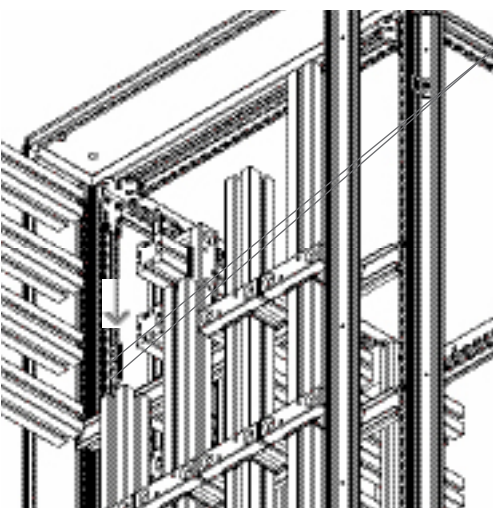

1600	9640.980
2000	9640.980
3200	9650.990

1600	9676.972
2000	9676.973
3200	9676.983

В 24.2.1.4

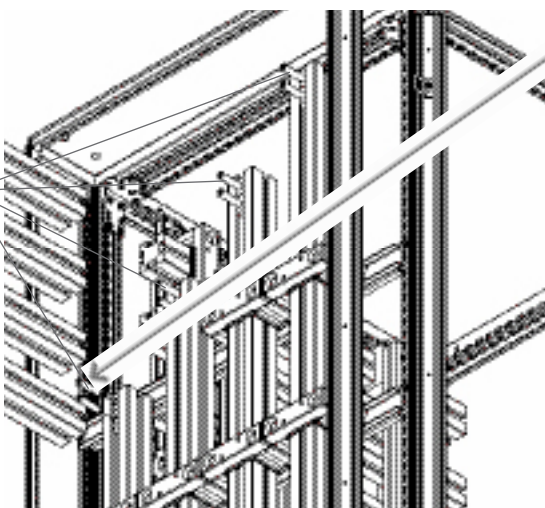

В 24.2.1.5

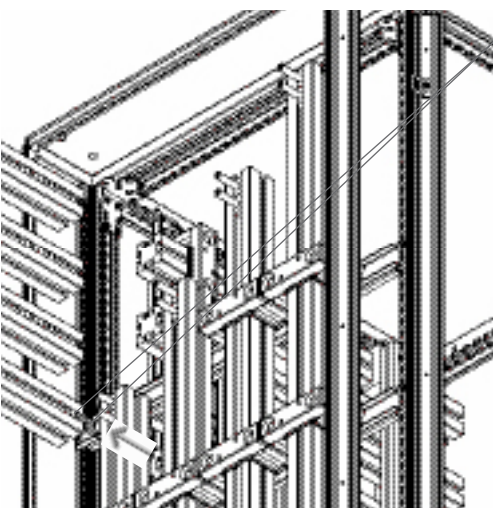

1600	9640.980
2000	9640.980
3200	9650.990

В 24.2.1.6

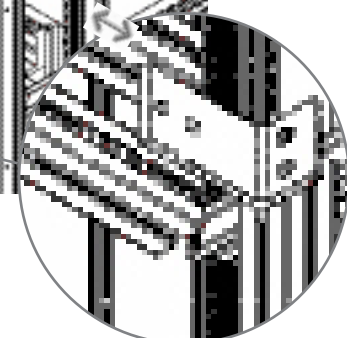
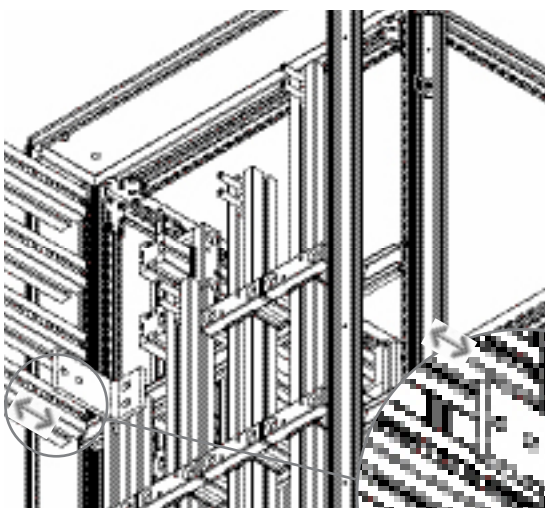

Соединение панели секционной перемычки с Maxi-PLS

Сборка панели секционной перемычки Assembling the coupling set assembly kit

B 24.2.2.1

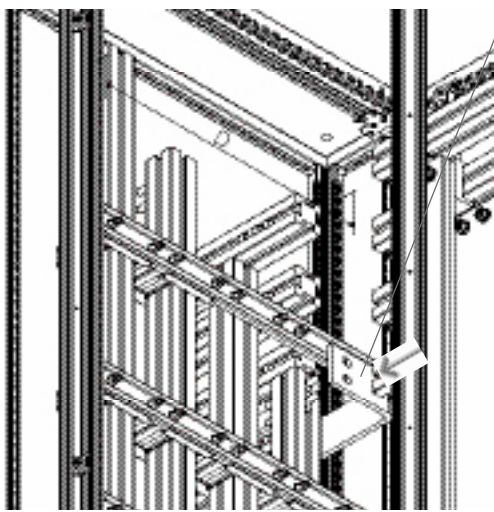

D		
1600	600/800	9660.318
2000	600/800	9660.313
3200	600	9660.363
3200	800	9660.368

B 24.2.2.2

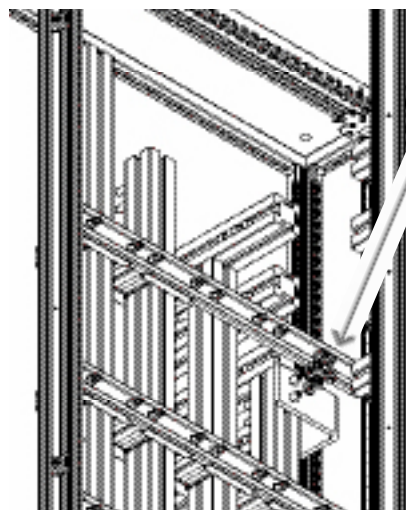

B 24.2.2.3

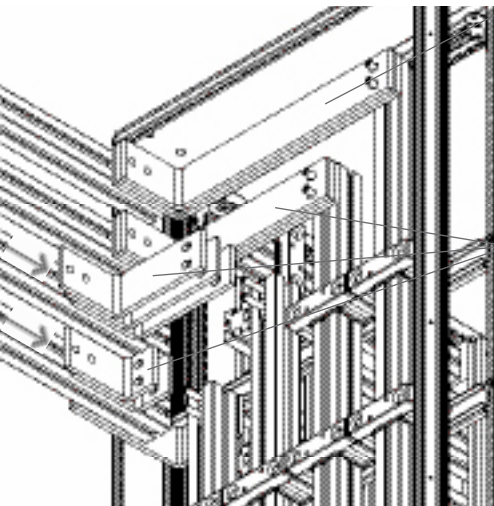

N		
D		
1600	600/800	9660.319
2000	600/800	9660.314
3200	800	9660.369

L1 - L3		
D		
1600	600/800	9660.318
2000	600/800	9660.313
3200	600	9660.363
3200	800	9660.368

B 24.2.2.4

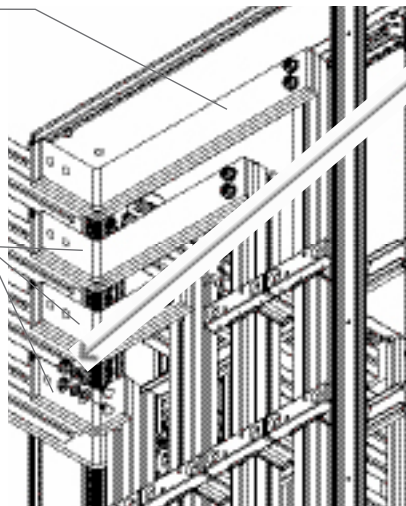

B 24.2.2.5

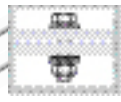
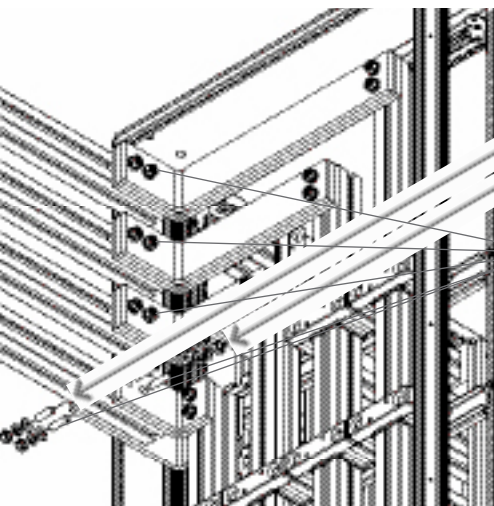

1600	9676.972
2000	9676.973
3200	9676.983

B 24.2.2.6

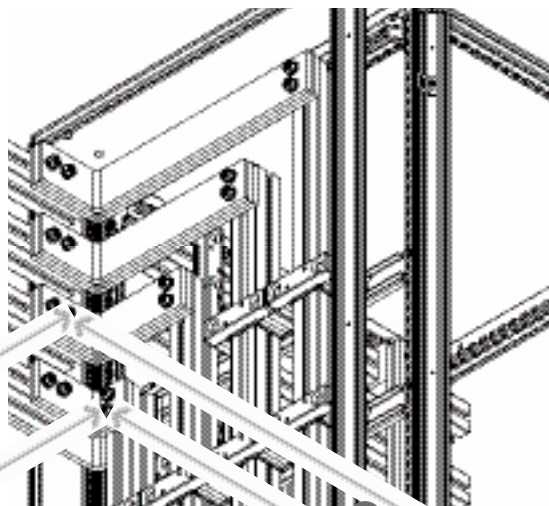

1

2

	1600	SW 5	10 Nm
	2000	SW 5	10 Nm
	3200	SW 6	10 Nm

	1600	SW 16/17	20 Nm
	2000	SW 16/17	20 Nm
	3200	SW 18/19	40 Nm

Соединение панели секционной перемычки с Maxi-PLS

B 24.3.1

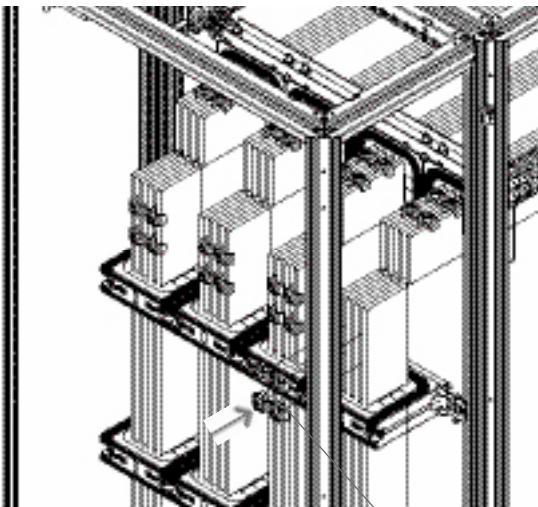

B 24.3.2.1

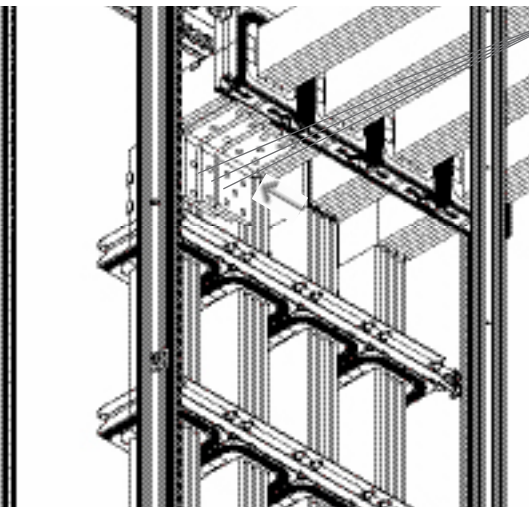

9675.842 – 9675.843
9675.882 – 9675.883
9675.892 – 9675.893

9676.832

B 24.3.2.2

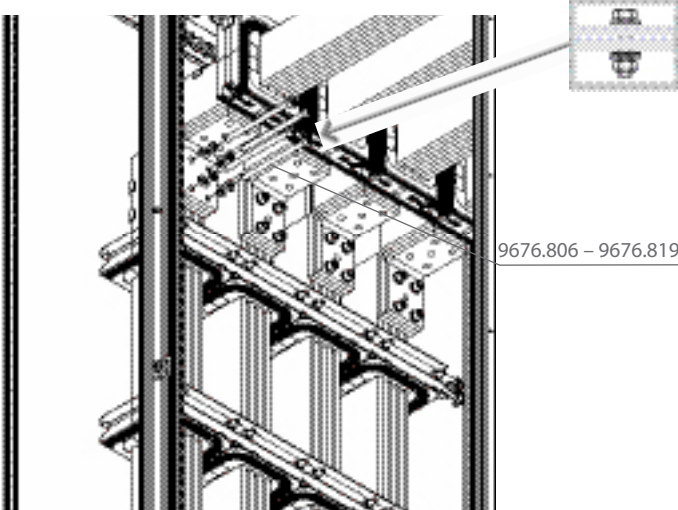

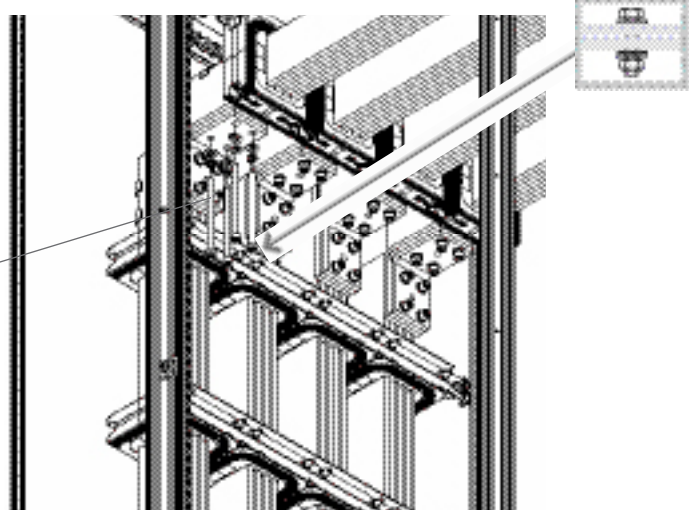

B 24.3.2.3



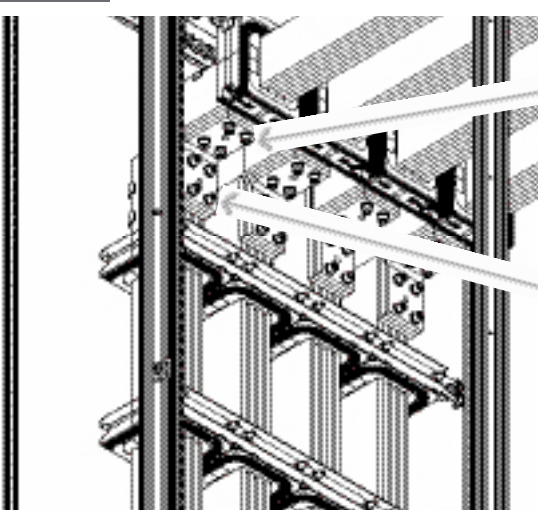

9676.806 – 9676.819

B 24.3.2.4



	Flat-PLS 60	SW 8	20 Nm
	Flat-PLS 100	SW 8	20 Nm

	Flat-PLS 60	SW 8	20 Nm
	Flat-PLS 100	SW 8	20 Nm

Соединение панели секционной перегородки с Flat-PLS

Сборка панели секционной перегородки Assembling the coupling set assembly kit

B 24.4.1.1

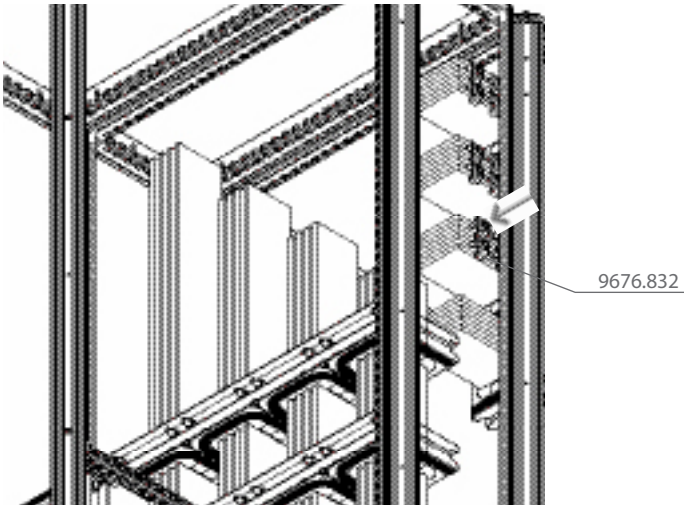

B 24.4.1.2

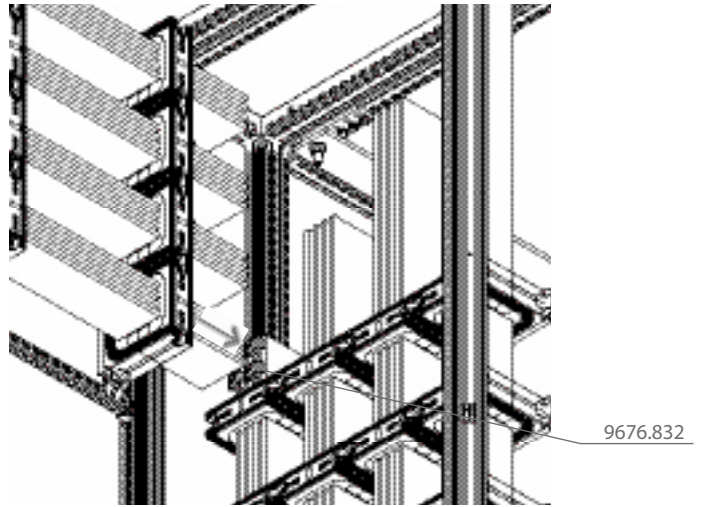

B 24.4.2.1

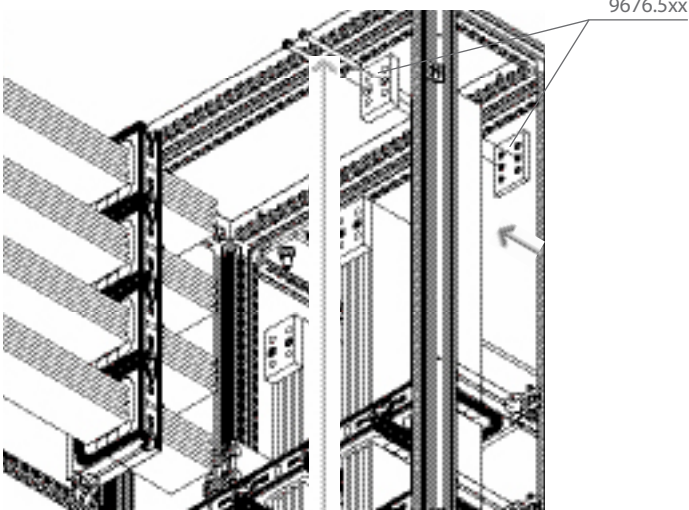

B 24.4.2.2

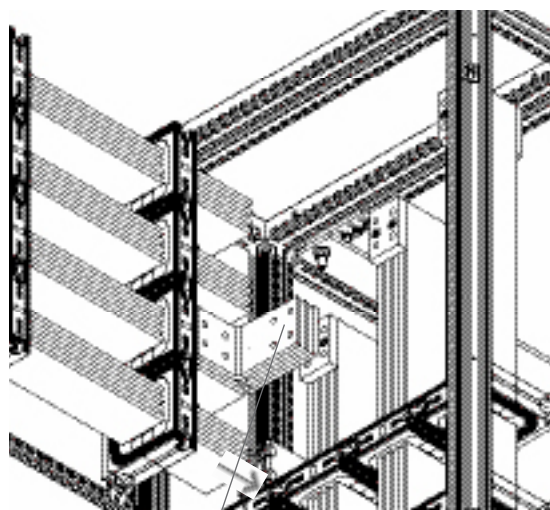

	Flat-PLS 60	SW 8	20 Nm
	Flat-PLS 100	SW 8	20 Nm

9675.846 - 9675.878
9675.886 - 9675.889
9675.896 - 9675.898

B 24.4.2.3

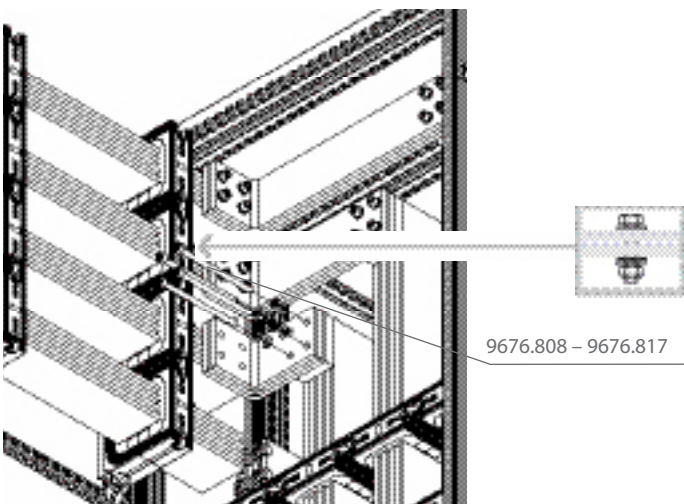

B 24.4.2.4

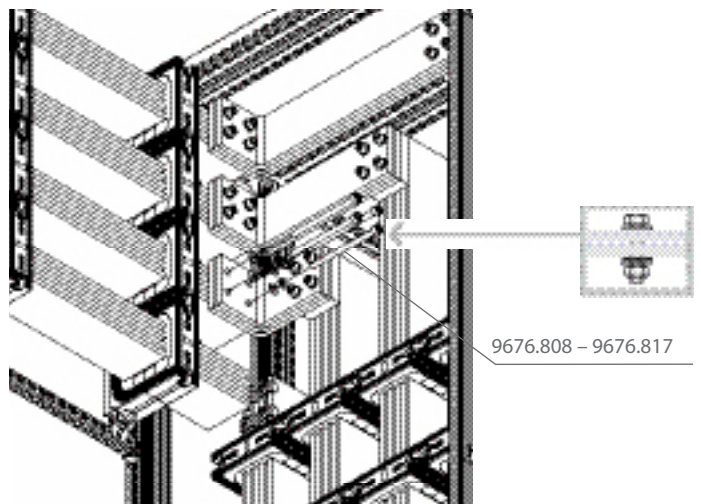

Соединение панели секционной перемычки с Flat-PLS

B 24.4.3.1

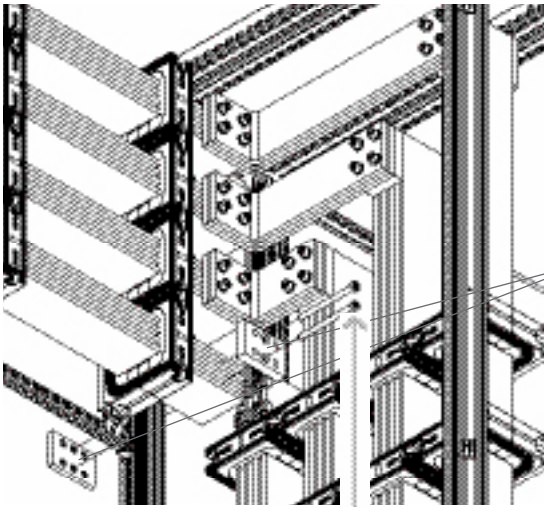

9676.5xx



Flat-PLS 60	SW 8	20 Nm
Flat-PLS 100	SW 8	20 Nm

B 24.4.3.2

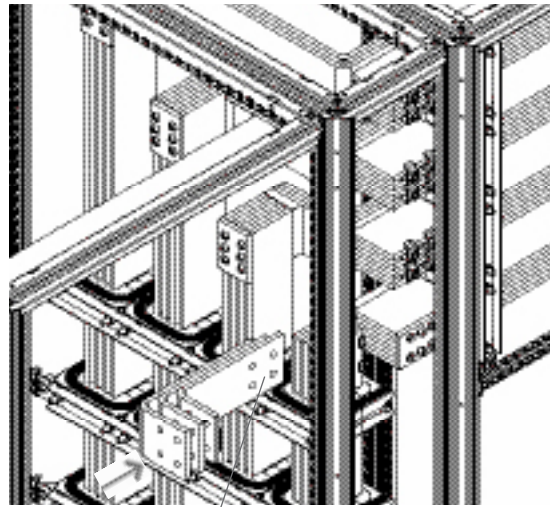

9675.846 – 9675.878
9675.886 – 9675.889
9675.896 – 9675.898

B 24.4.3.3

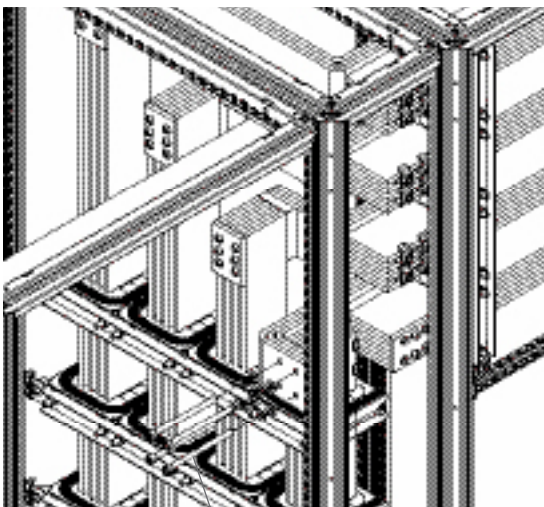

9676.808 – 9679.815



Flat-PLS 60	SW 8	20 Nm
Flat-PLS 100	SW 8	20 Nm



Flat-PLS 60	SW 8	20 Nm
Flat-PLS 100	SW 8	20 Nm

B 24.4.3.4

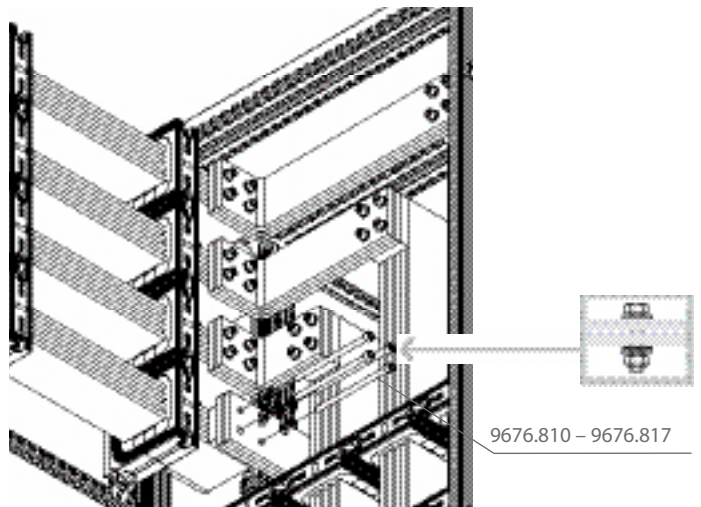

9676.810 – 9676.817

B 24.4.3.5

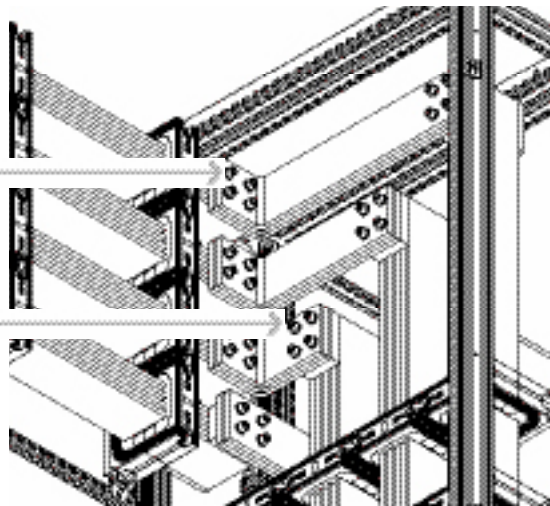

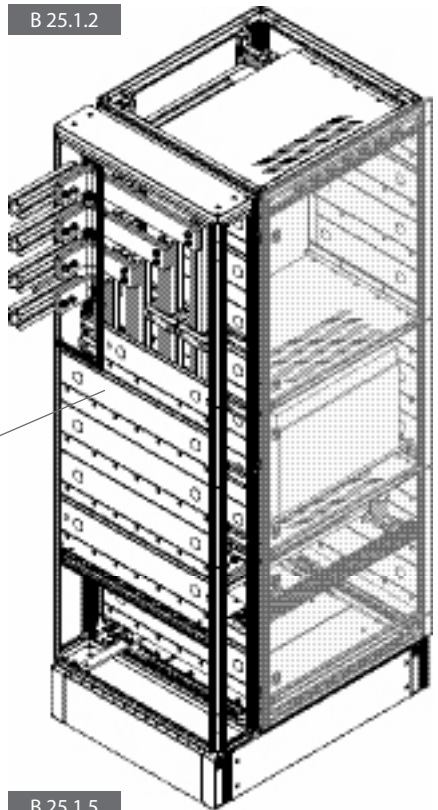
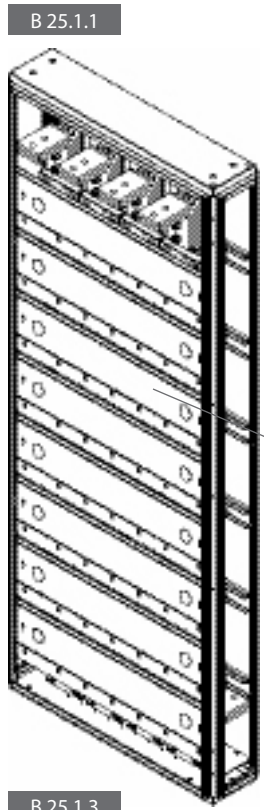

Сборка секционирования для секционной перемычки

Сборка панели секционной перемычки Assembling the coupling set assembly kit

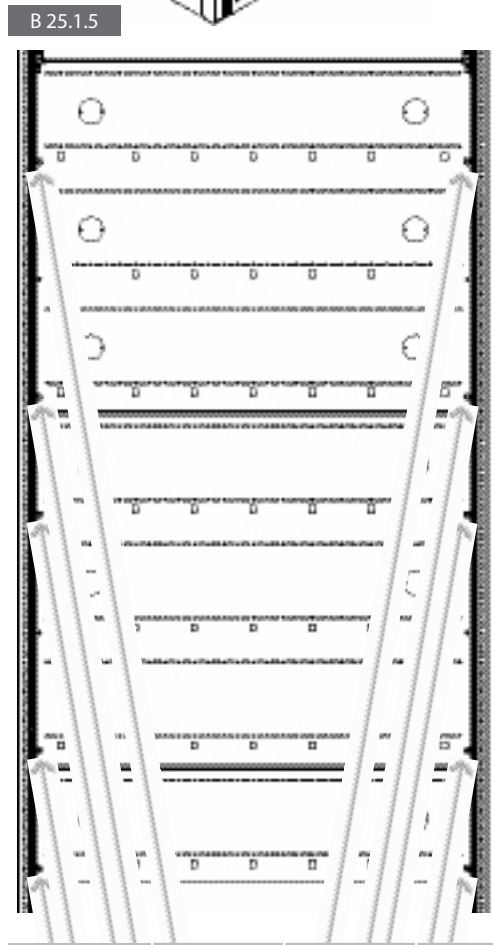
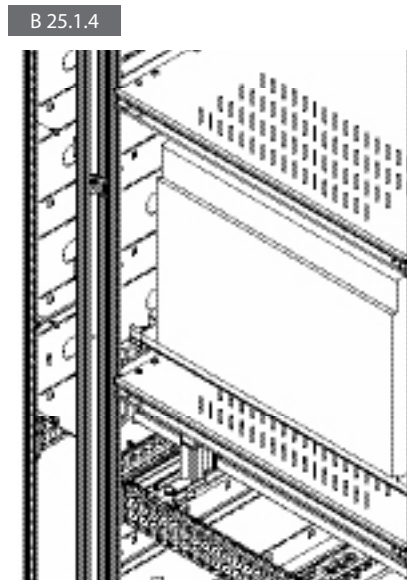
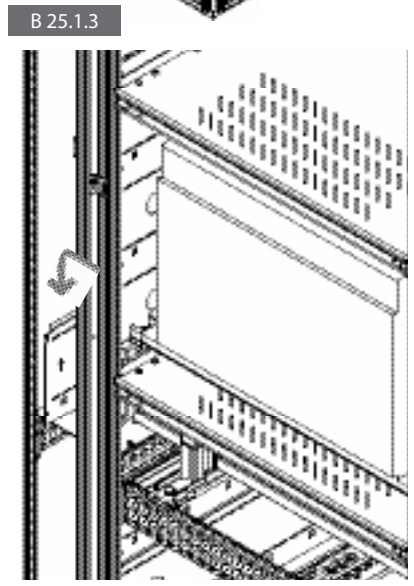

9673.051 – 9673.086



			
		T 25	5 Nm

Установка задней стенки

B 26.1.1

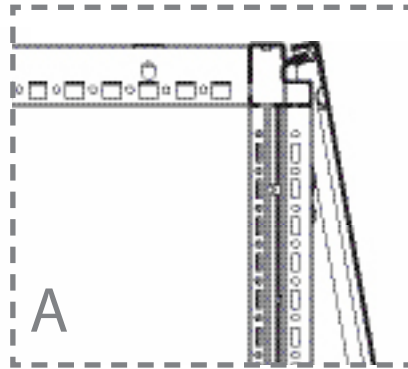
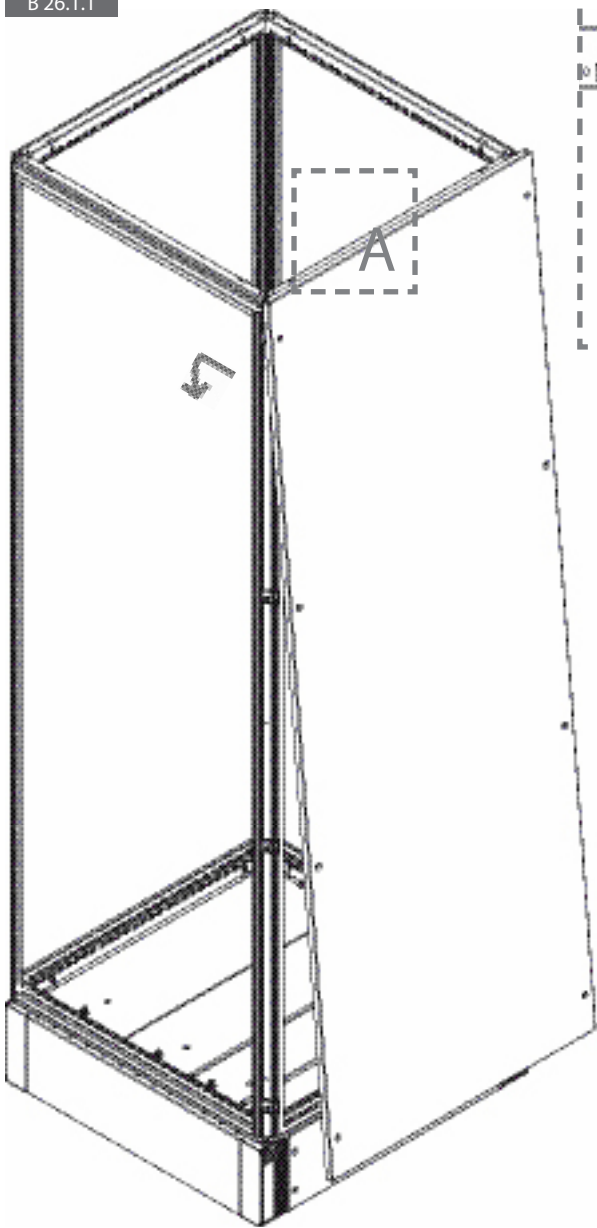

B 26.1.2

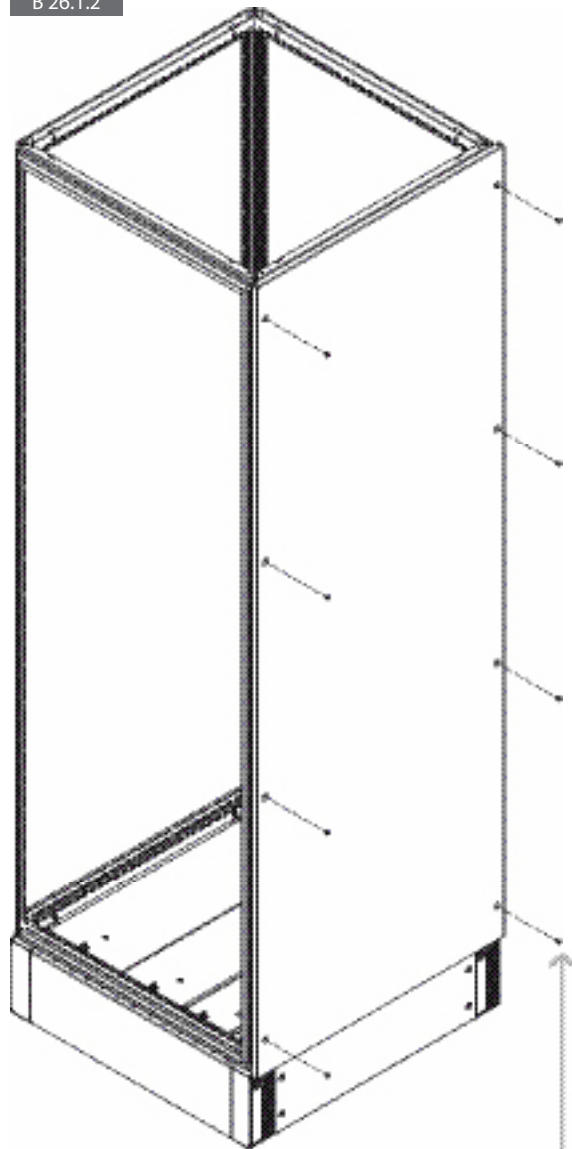

		T 30	5 Nm

Установка передней панели для 200 мм секции

Установка передней панели для 200мм секции Assembling the front panel of 200mm wide busbar enclosure

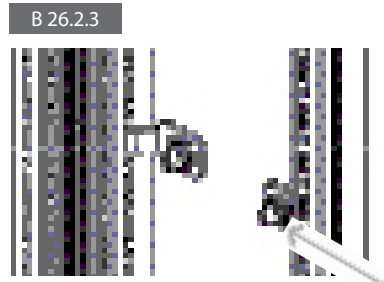
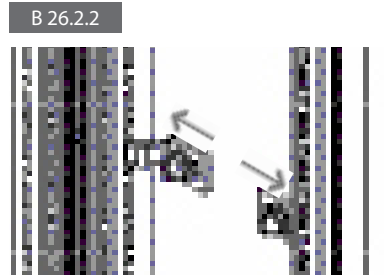
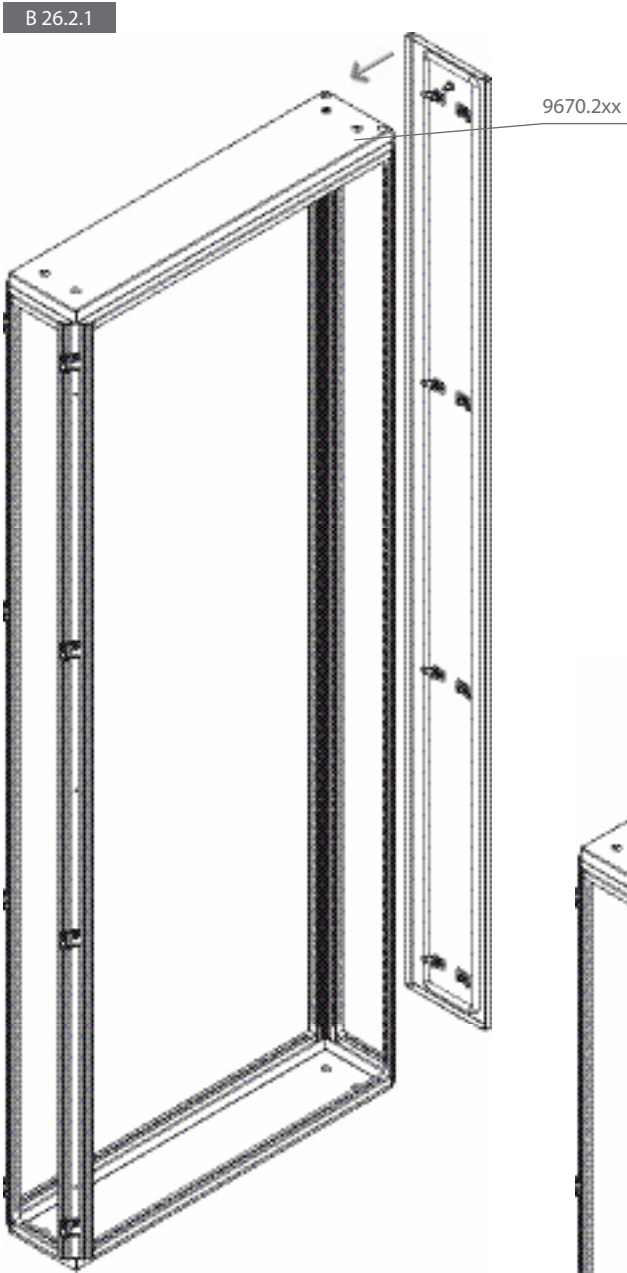

SW 10	5 Nm
-------	------

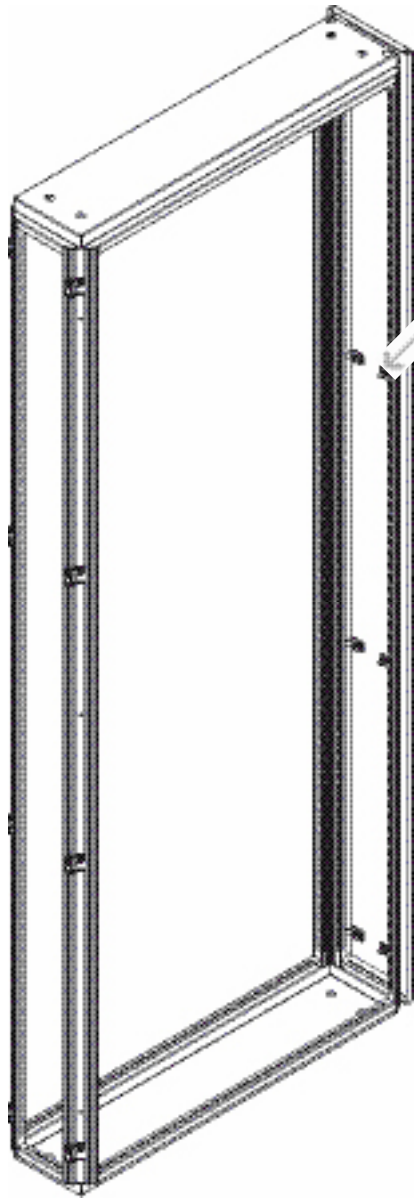

Установка двери для кабельного канала

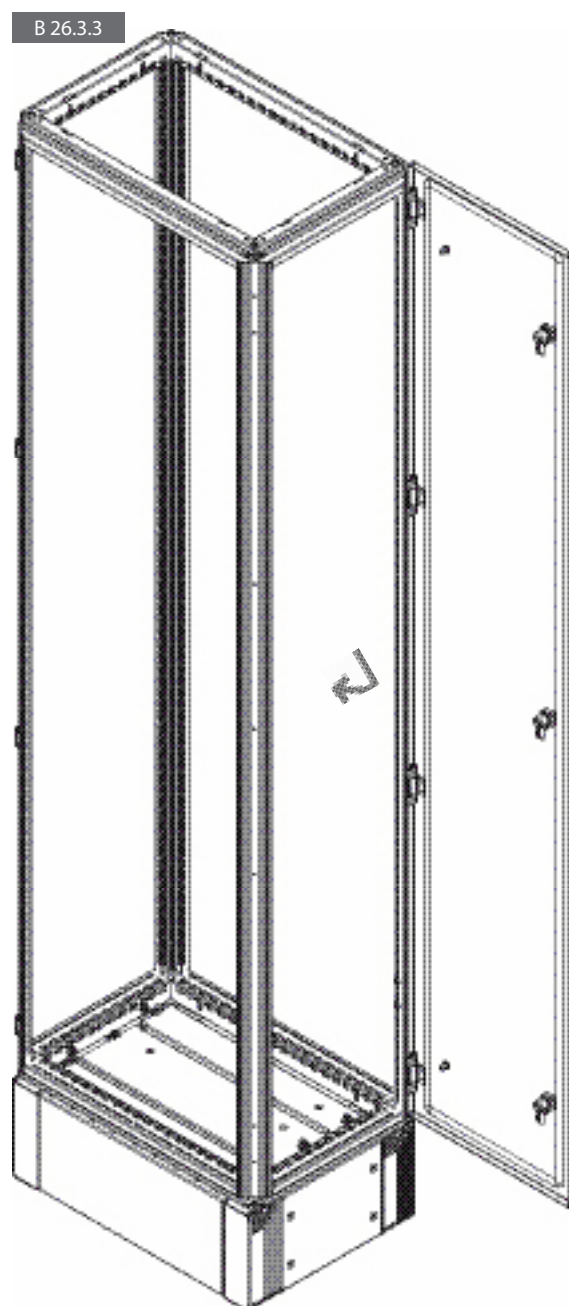
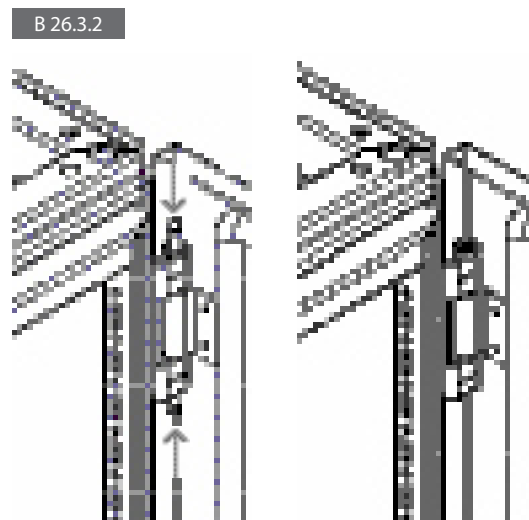

Установка кабельных клемм на Maxi-PLS

B 27.1.1.1



B 27.1.1.2

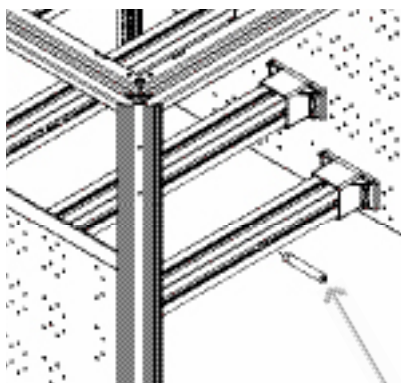

B 27.1.1.3

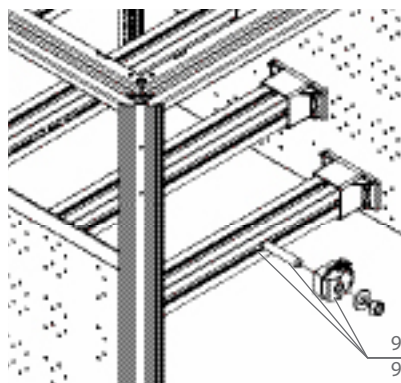

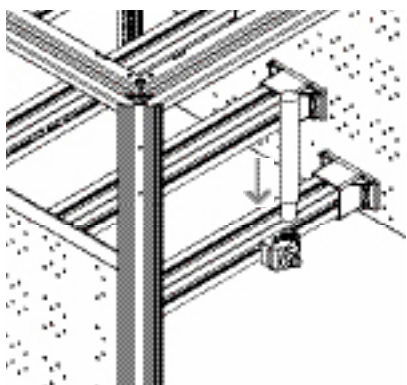

9640.325
9650.325

B 27.1.1.4

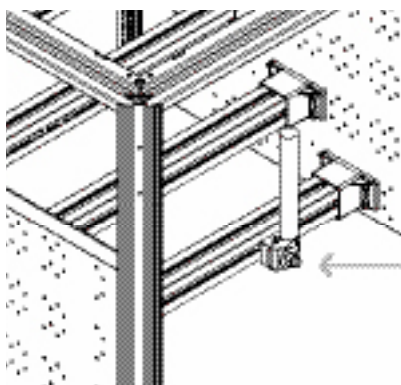

B 27.1.1.5



			
		SW 5/6	10 Nm

			
		SW 18/19	40 Nm

B 27.1.2.1



B 27.1.2.2

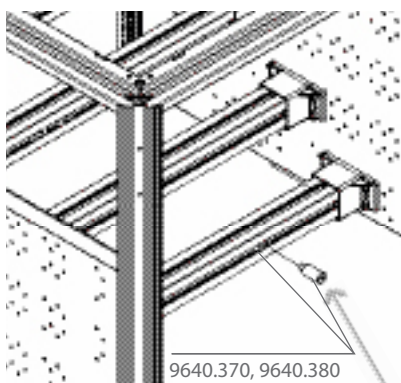

9640.370, 9640.380
9650.370, 9650.380

B 27.1.2.3

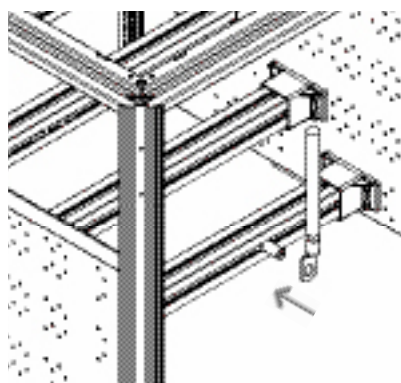

B 27.1.2.4

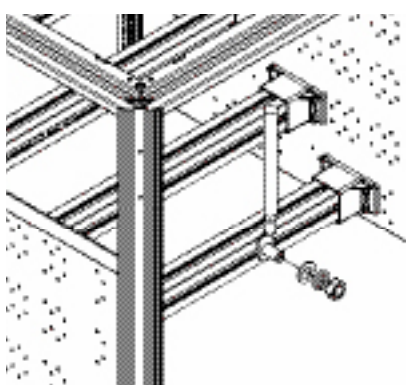

B 27.1.2.5

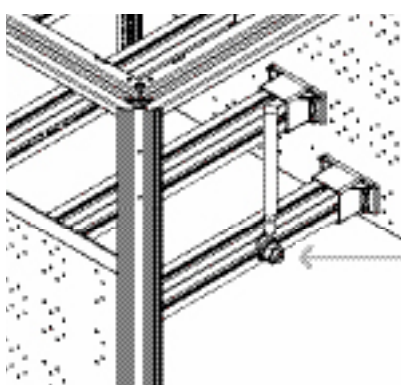

			
		SW 6 SW 8	10 Nm 10 Nm

			
		SW 18/19 SW 23/24	40 Nm 40 Nm

Установка кабельных клемм на Maxi-PLS

B 27.1.3.1



1600/2000			
		35 mm	6 mm
M 6	9640.900	9640.930	-
M 8	9640.910	9640.940	-
M 10	9640.920	9676.971	9676.977
3200			
M 6	9650.900	9640.930	-
M 10	9650.910	9676.971	9676.977
M 12	9650.920	-	9676.987

B 27.1.3.2

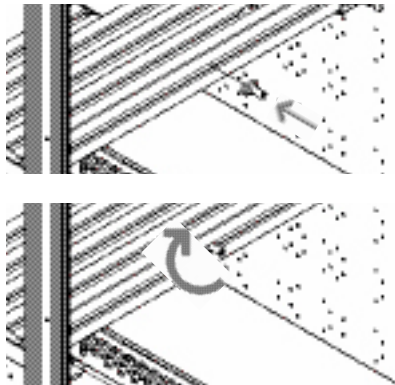

B 27.1.3.3

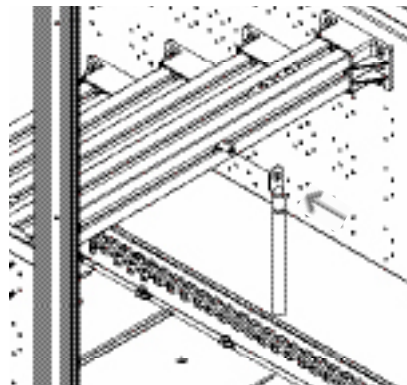

B 27.1.3.4

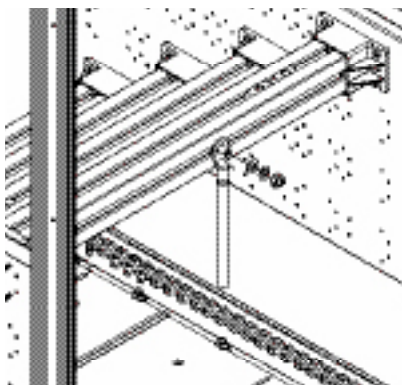

B 27.1.3.5

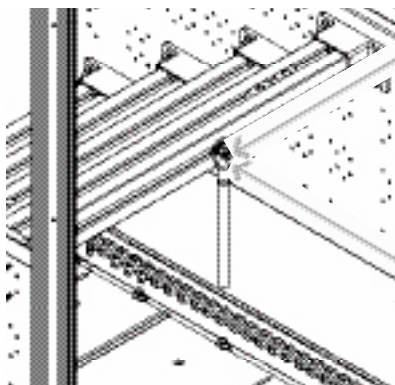

	M 6	SW 3	5 Nm
	M 8	SW 4	10 Nm
	M 10	SW 5	10 Nm
	M 12	SW 6	10 Nm

	M 6	SW 10	5 Nm
	M 8	SW 13	15 Nm
	M 10	SW 16/17	20 Nm
	M 12	SW 18/19	40 Nm

B 27.1.4.1

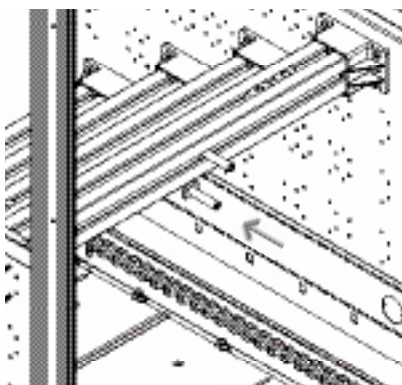

B 27.1.4.2

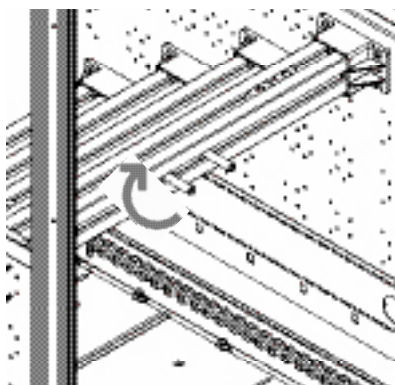

B 27.1.4.3

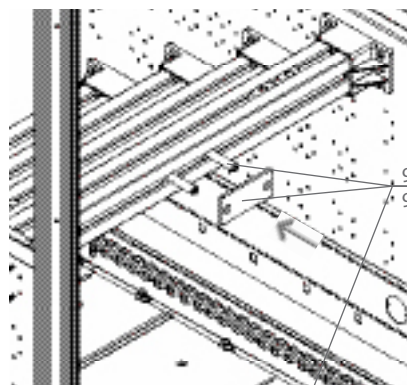

9640.330 - 350
9650.330 - 350

B 27.1.4.4

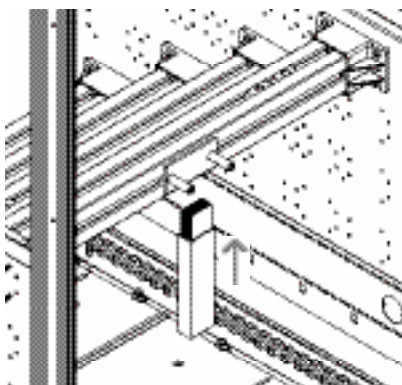

B 27.1.4.5

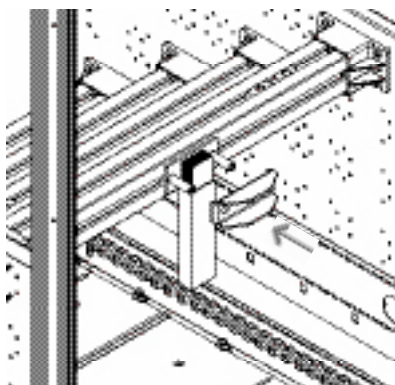

B 27.1.4.6

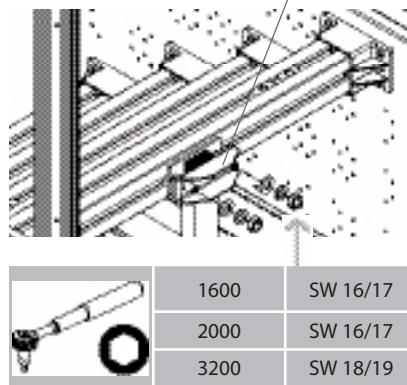

	1600	SW 16/17	20 Nm
	2000	SW 16/17	20 Nm
	3200	SW 18/19	40 Nm

Установка адаптеров подключения RiLine60

B 27.2.1.1

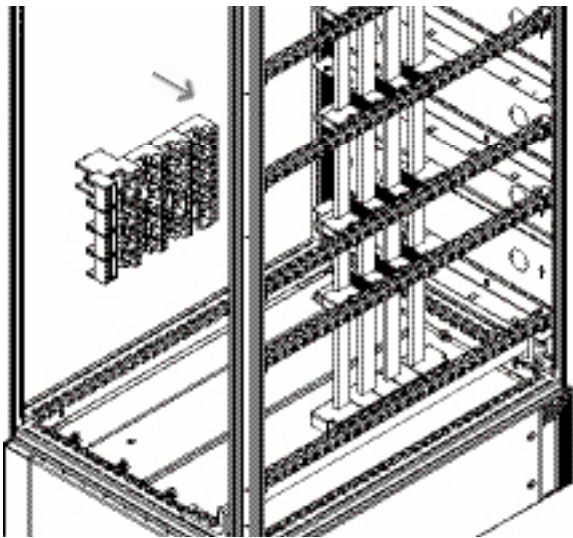

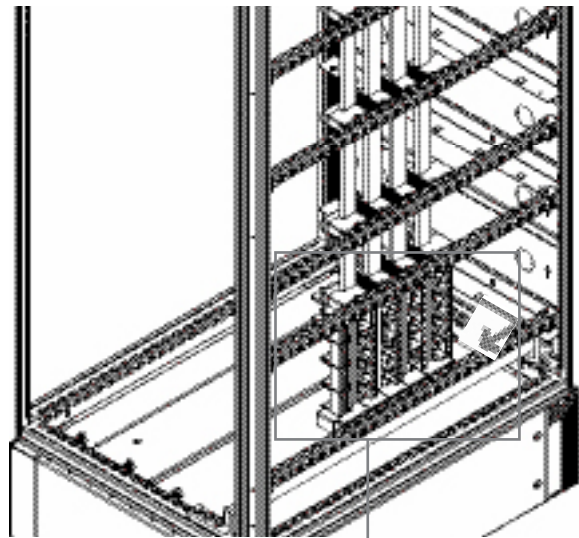

B 27.2.1.2

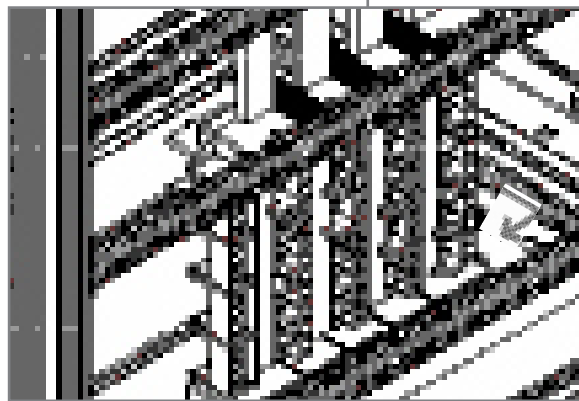
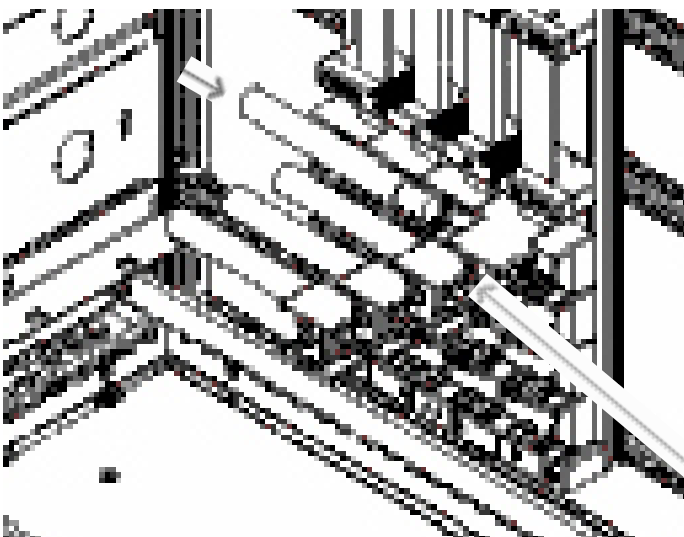

B 27.2.1.3



	9342.31x	SW 5	12 – 14 Nm
	9342.32x	SW 8	15 – 20 Nm

B 27.2.1.4

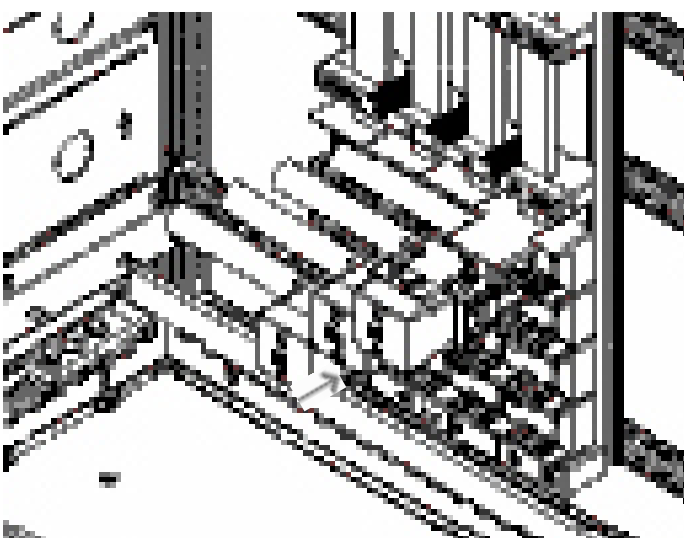

B 27.2.1.5

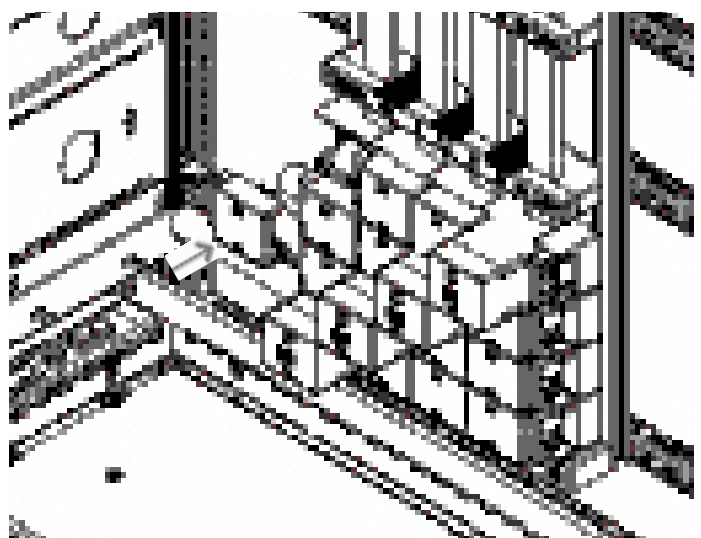

Установка адаптеров подключения RiLine60

B 27.2.2.1

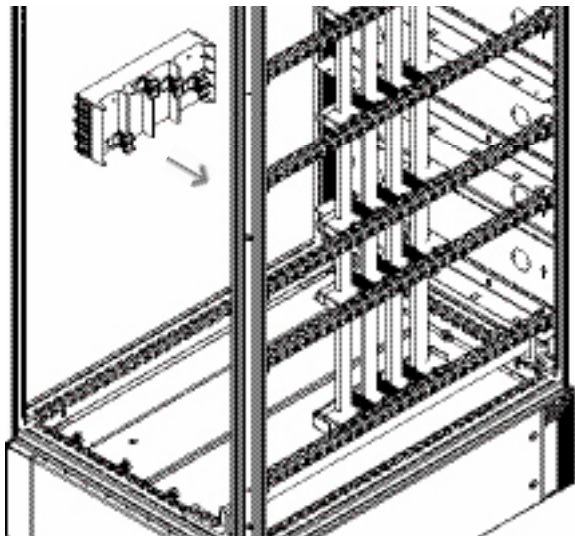

B 27.2.2.2

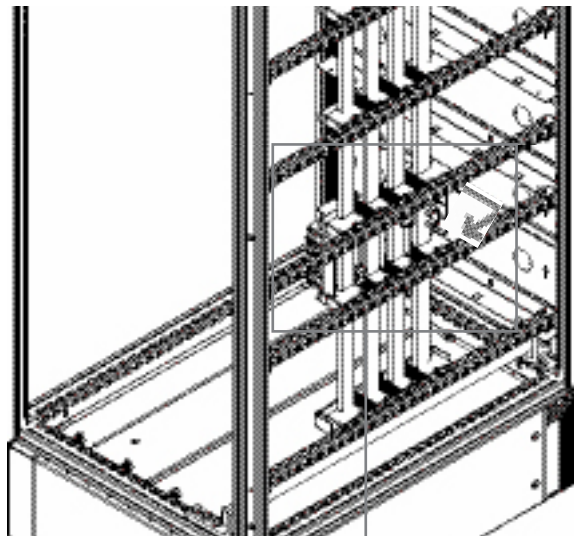

B 27.2.2.3

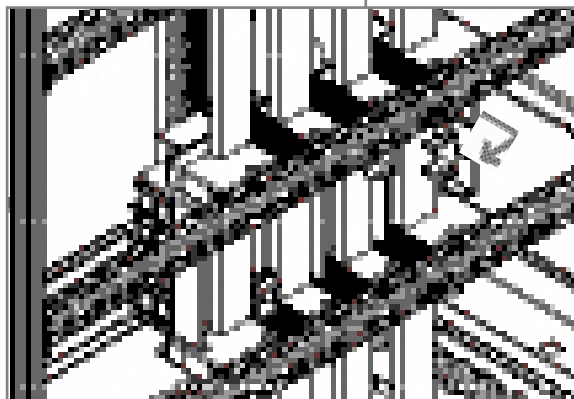
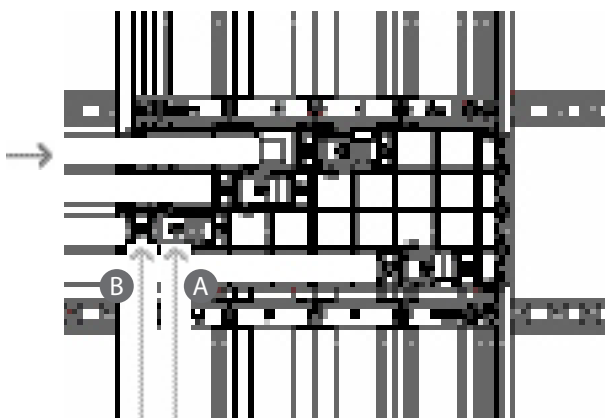

9342.200/9342.210	A	PH 2		2 Nm
	B	PH 2		2,5 Nm
9342.22x/9342.23x 9342.24x	A	PH 2		2 Nm
	B	PZ 2		2 – 3 Nm
9342.25x/9342.26x 9342.27x	A	SW 4		4 – 6 Nm
	B	SW 4		12 Nm
9342.28x/9342.29x 9342.30x	A	SW 4		6 Nm
	B	SW 5		12 – 14Nm

B 27.2.2.4

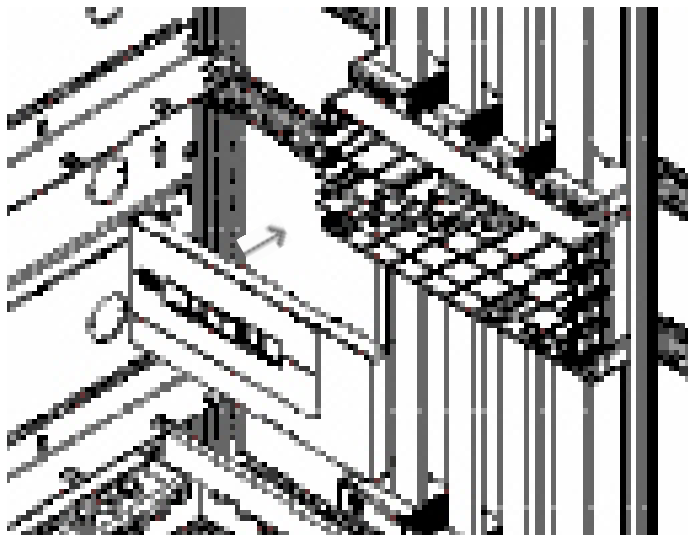

Установка приборных адаптеров RiLine60

B 27.2.3.1

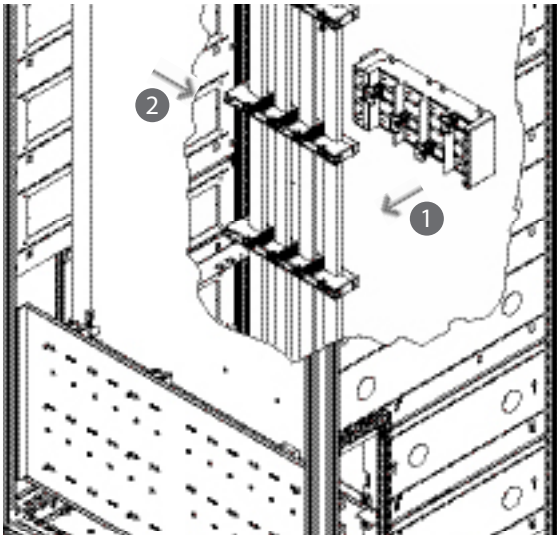

B 27.2.3.2

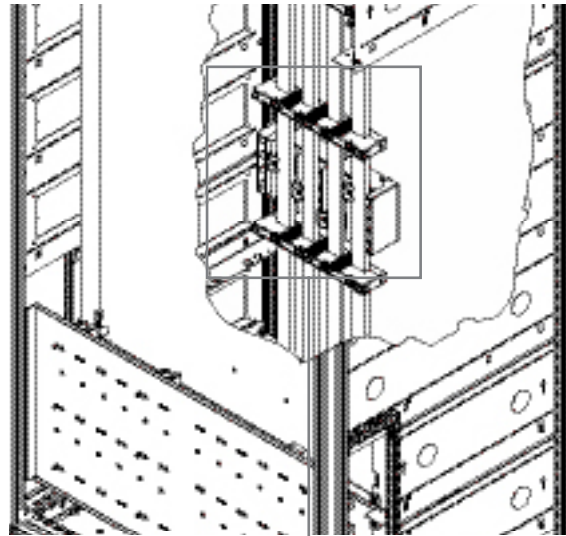

B 27.2.3.3

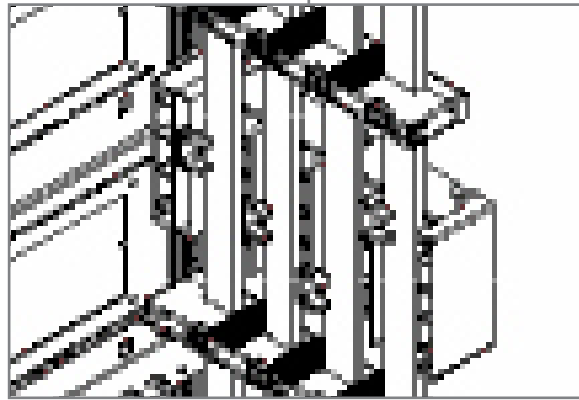
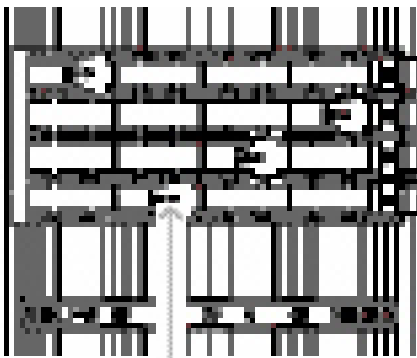

9342.400/9342.410	PZ 2	⊗	2 Nm
9342.50x/9342.51x	SW 4	⬤	4 – 6 Nm
9342.54x/9342.55x	SW 4	⬤	4 – 6 Nm
9342.60x/9342.61x	SW 4	⬤	4 – 6 Nm
9342.700/9342.710	SW 5	⬤	12 – 14 Nm

B 27.2.3.5

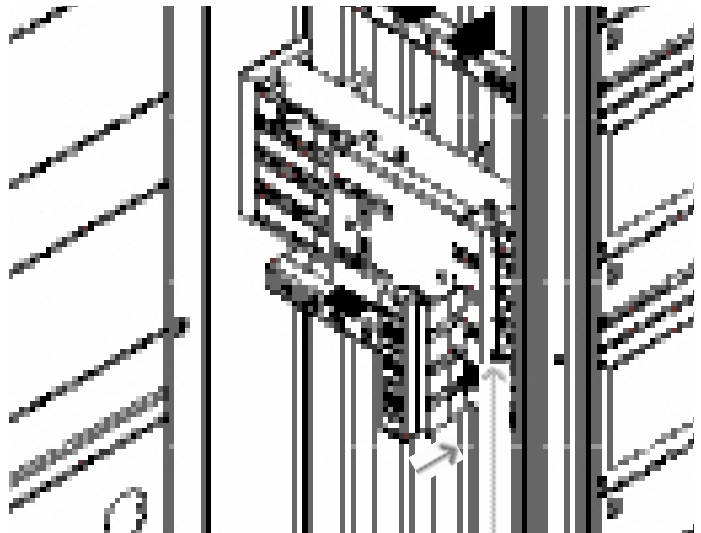

B 27.2.3.4



9342.400/9342.410	PZ 2	⊗	2 – 3 Nm
9342.50x/9342.51x	SW 4	⬤	12 Nm
9342.54x/9342.55x	SW 4	⬤	12 Nm
9342.60x/9342.61x	SW 4	⬤	12 Nm
9342.700/9342.710	SW 16/17	⊙	30 – 32 Nm

Установка приборных адаптеров RiLine60

B 27.2.4.1

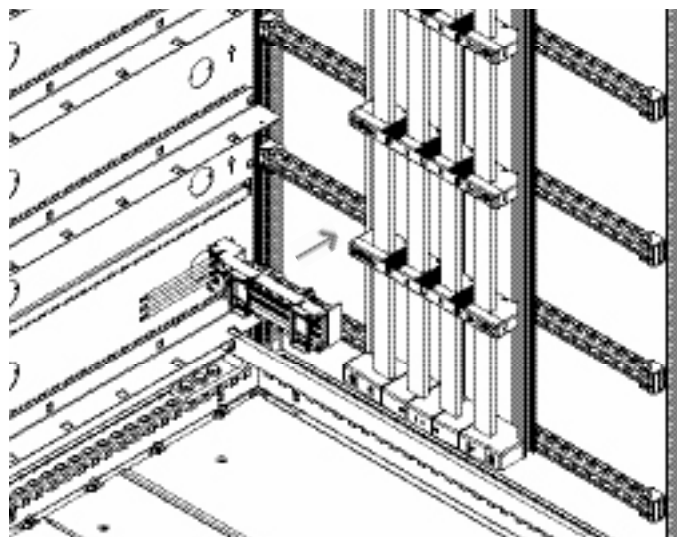
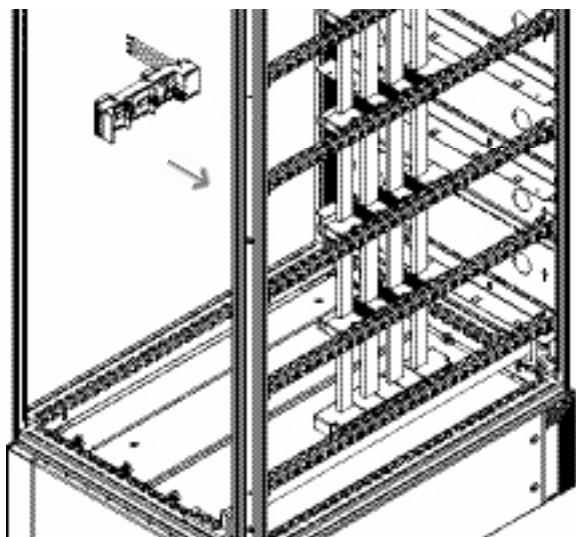

B 27.2.4.2

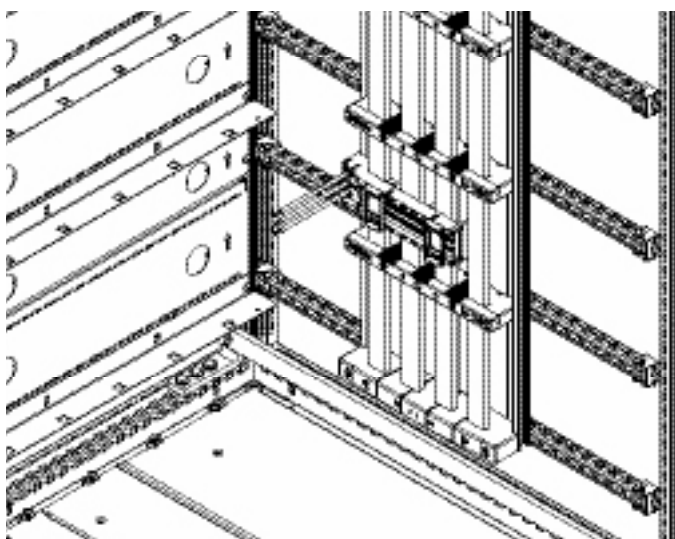

Установка кабельных клемм на Flat-PLS

B 27.3.1.1

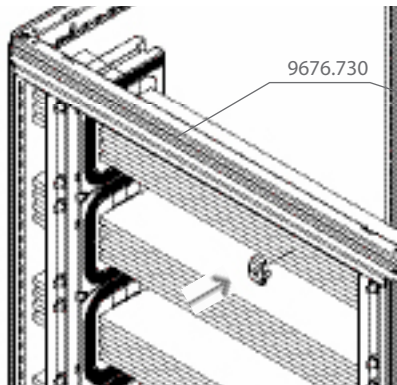

B 27.3.1.2

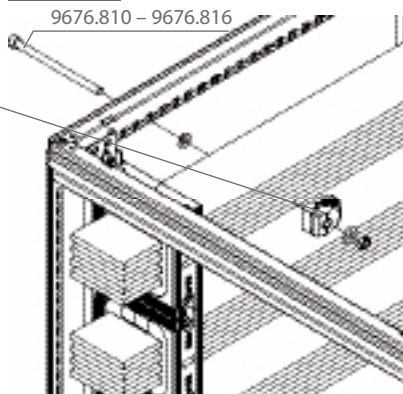

B 27.3.1.3

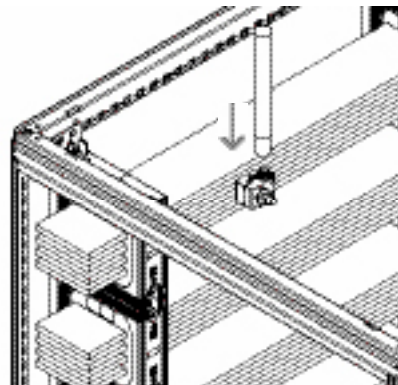

B 27.3.1.4

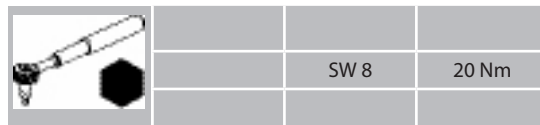
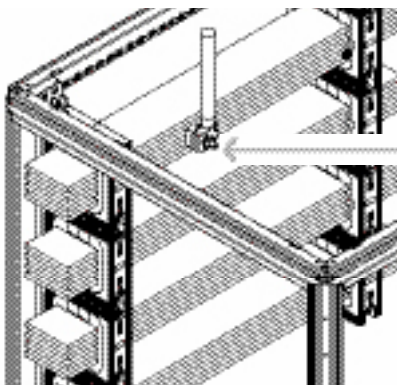

B 27.3.2.1

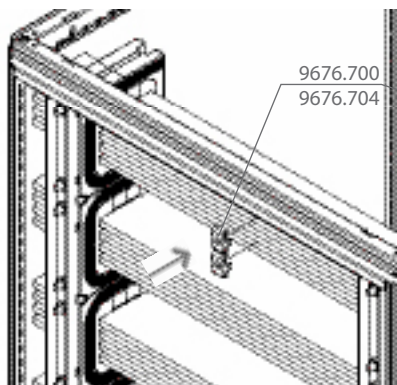

B 27.3.2.2

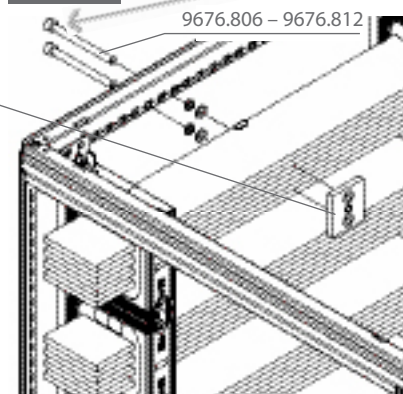

B 27.3.2.3

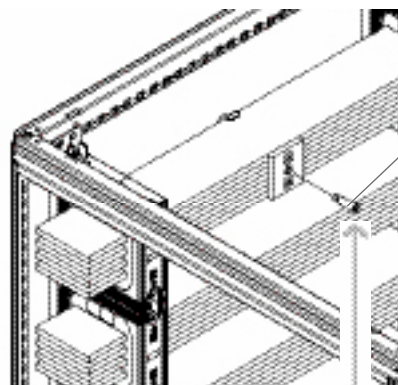

B 27.3.2.4

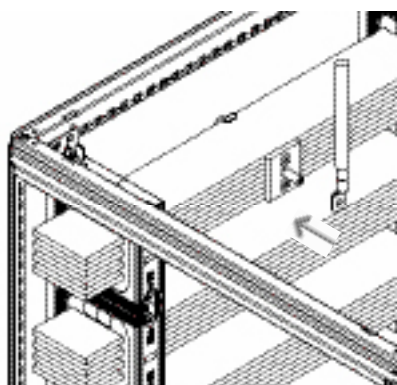

B 27.3.2.5

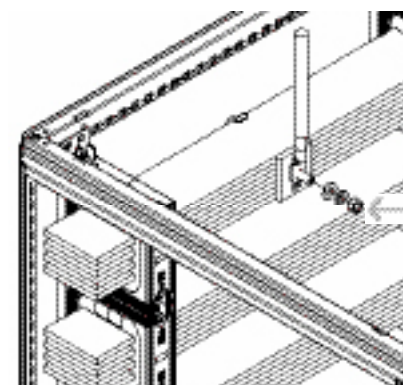

Установка кабельных клемм на Flat-PLS

B 27.3.3.1

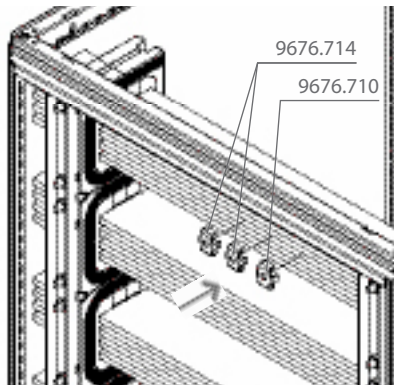

B 27.3.3.2

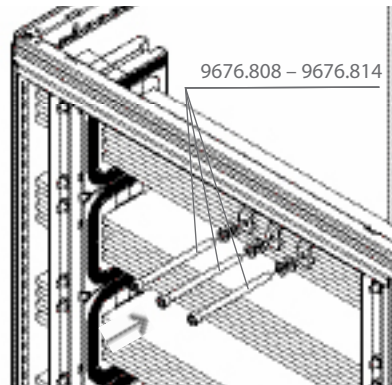

B 27.3.3.3

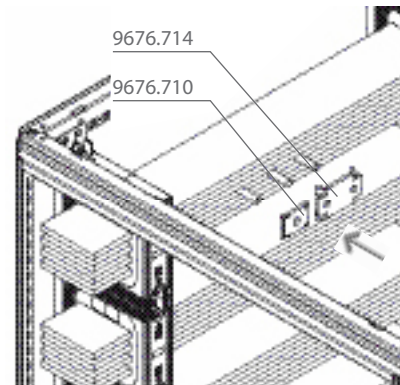

B 27.3.3.4

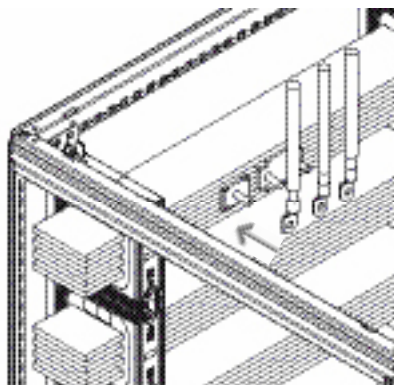

B 27.3.3.5

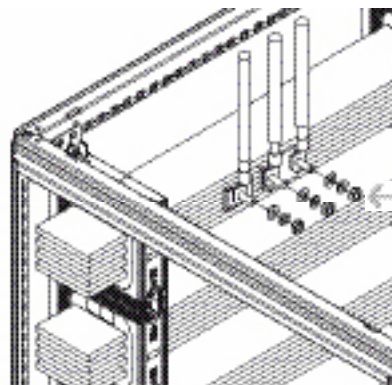

B 27.3.4.1

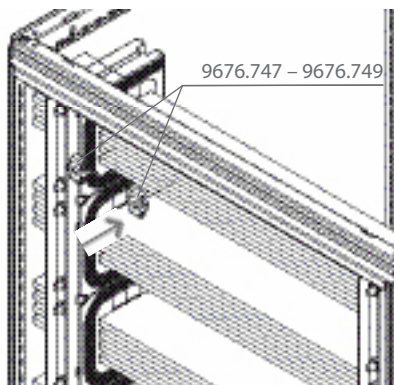

B 27.3.4.2

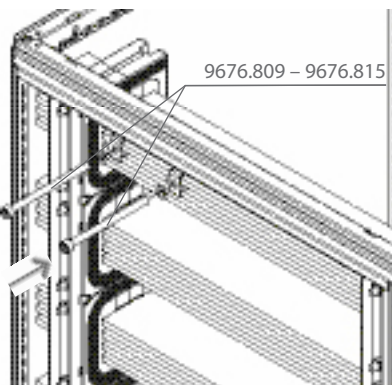

B 27.3.4.3

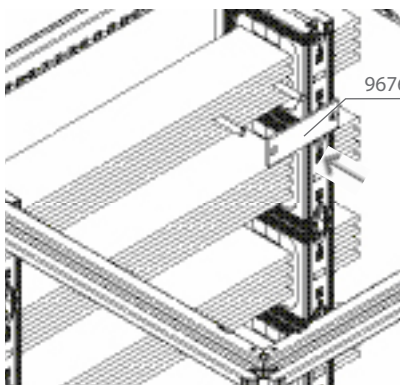

B 27.3.4.4

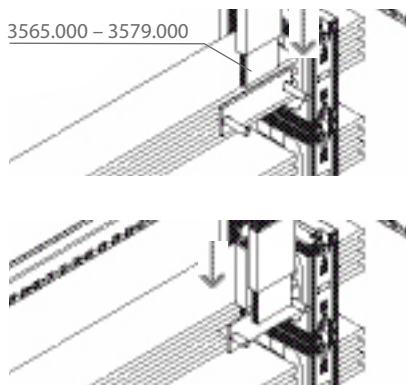

B 27.3.4.5

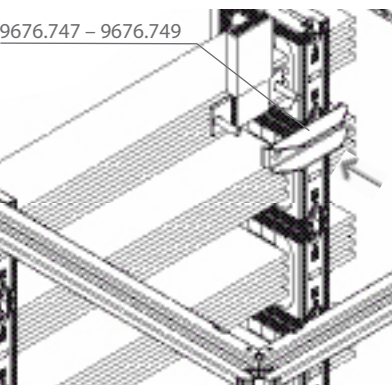

B 27.3.4.6

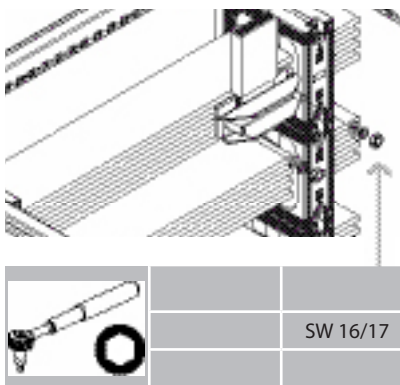

Установка секционирования шинной сборки в кабельном канале

Установка защиты шинной сборки в кабельном канале Assembling the cover of main busbar system

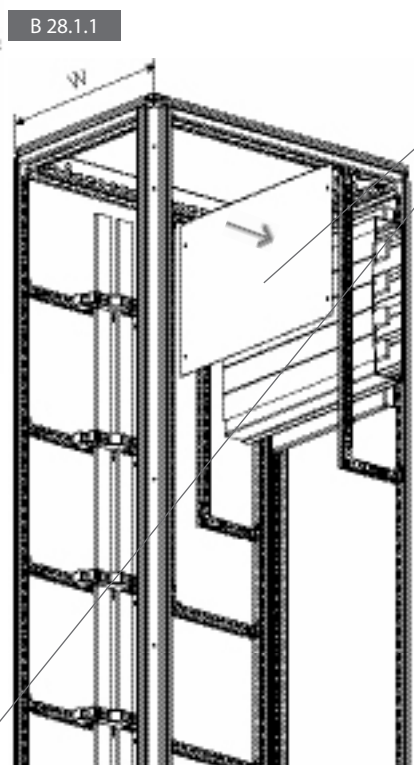
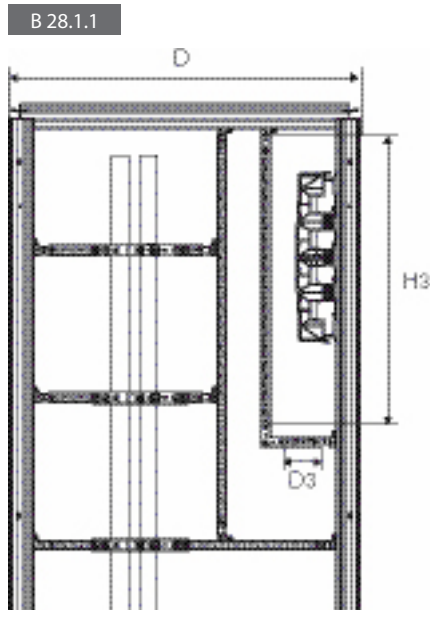

W	D	H3	D3		
300 mm	600 mm			9673.530	RiLine 60 Maxi-PLS 1600/2000
400 mm	600 mm	487,5 mm (9673.953)	62,5 mm (9673.915)	9673.540	
600 mm	600 mm			9673.560	
300 mm	600/800 mm	787,5 mm (9673.983)	137,5 mm (9673.920) oder/or 262,5 mm (9673.940)	9673.532	RiLine 60 Maxi-PLS 1600/2000/3200 Flat-PLS 60/100
400 mm	600/800 mm			9673.542	
600 mm	600/800 mm			9673.562	

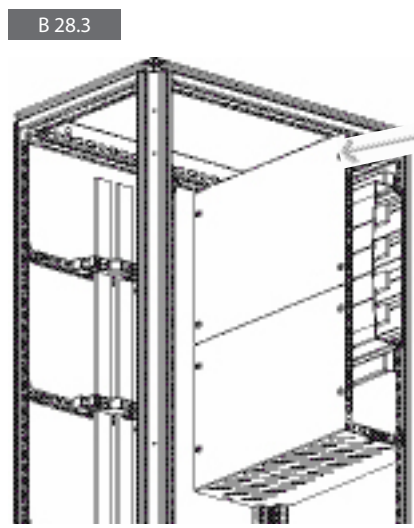
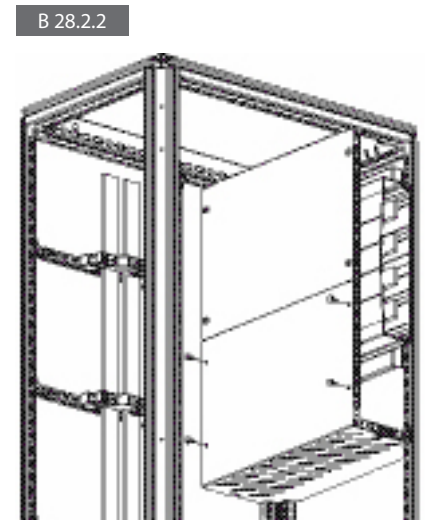
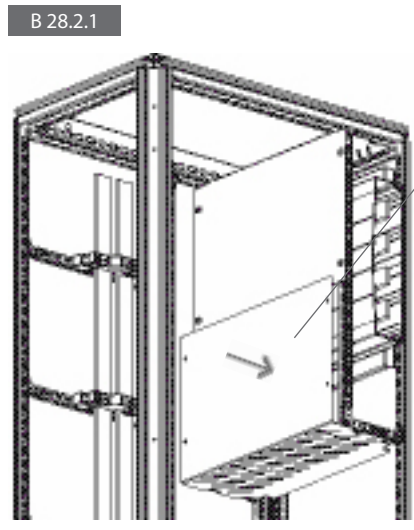
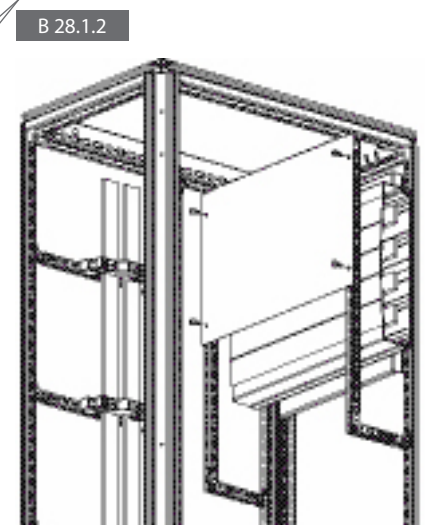

			T 25	5 Nm
---	--	--	------	------

Установка с-профилей для подвязки кабелей в кабельном канале

B 29.1.1

	9676.194	9676.196	9676.198
D	400 mm	600 mm	800 mm
F ↓	800 N	800 N	700 N

≤ 500 mm
 ≤ 600 mm
 ≤ 600 mm
 ≤ 500 mm
 ≤ 600 mm
 143,5 mm

B 29.1.2

		T 25	5 Nm
--	--	------	------

B 29.1.3.1

B 29.2.1

	4193.000	4191.000	4192.000
D	400 mm	600 mm	800 mm
F ↓	800 N	800 N	700 N

≤ 500 mm
 ≤ 600 mm
 ≤ 500 mm
 ≤ 500 mm
 $\geq 18,5$ mm

B 29.2.2

		T 25	5 Nm
		SW 6	20 Nm

B 29.2.3

Установка секционной стенки в панели с планочными разъединителями со сборными шинами сверху

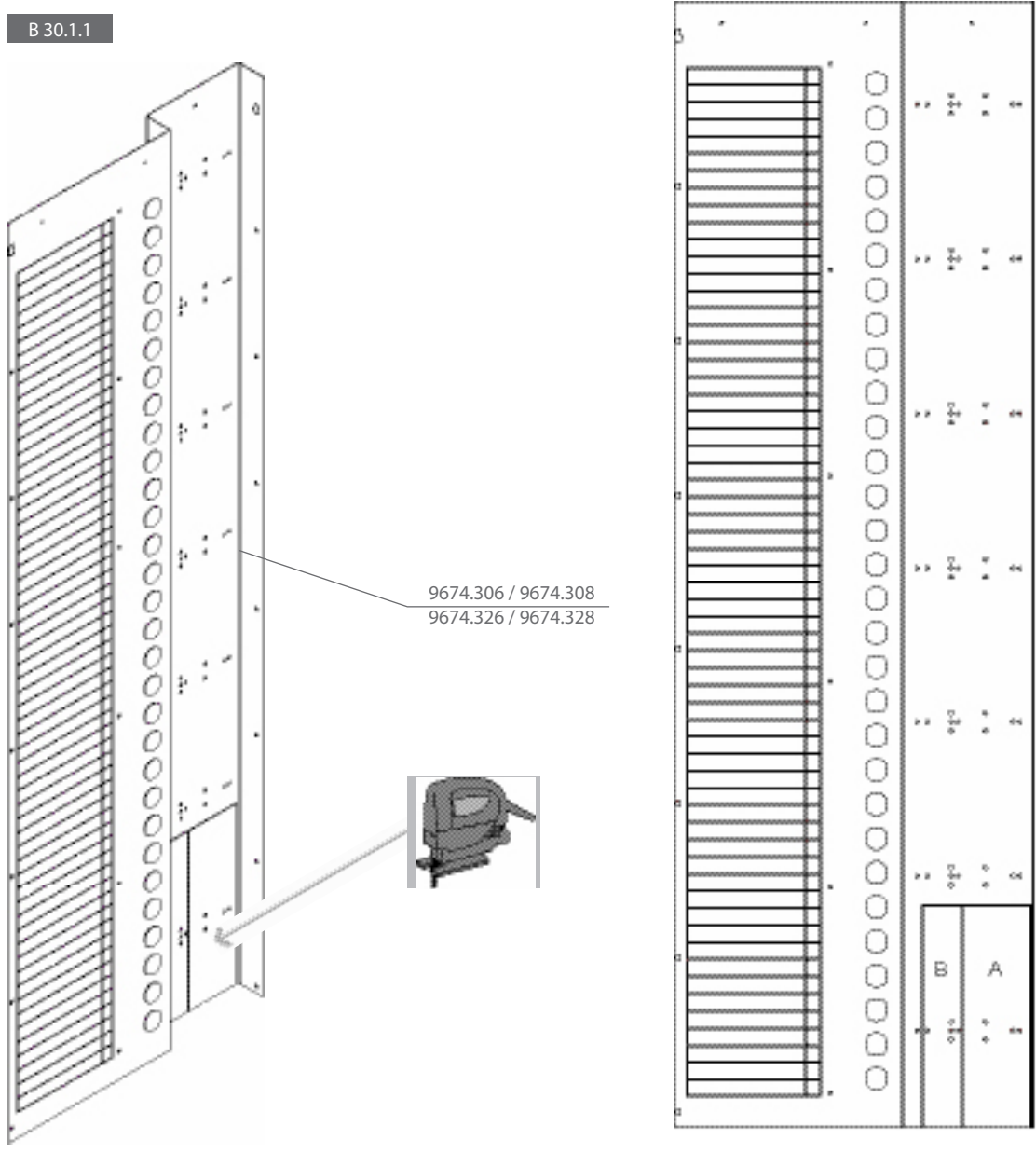

	A	B
PE/PEN в области основания / in bottom area		
PE + N/PEN (Maxi-PLS) в области основания / in bottom area	X	
PE + N/PEN (Flat-PLS) в области основания / in bottom area	X	X

Установка секционной стенки в панели с планочными разъединителями со сборными шинами сверху

B 30.1.2.1

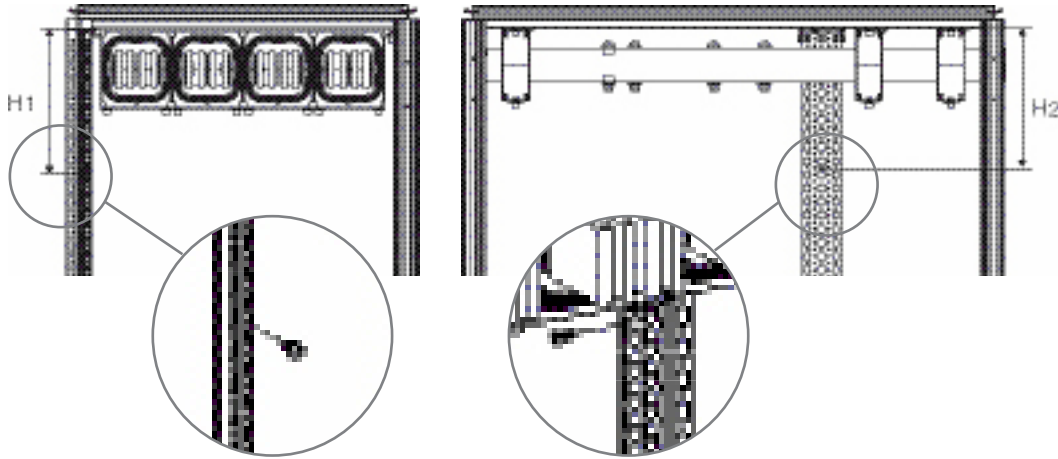

H	H1	H2
2000 mm	243 mm	256 mm
2200 mm	218 mm	231 mm

B 30.1.2.2

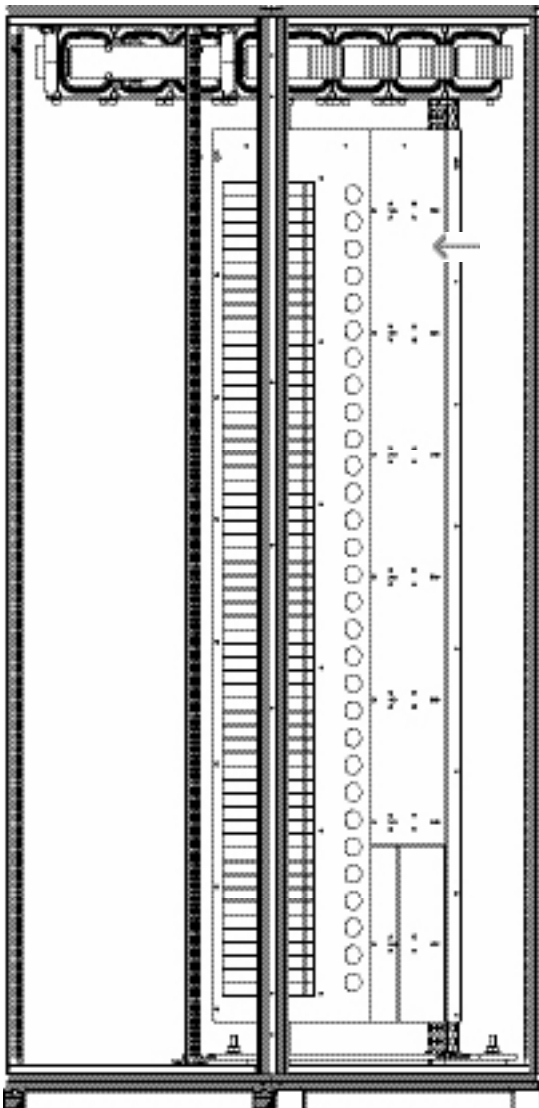

B 30.1.2.3

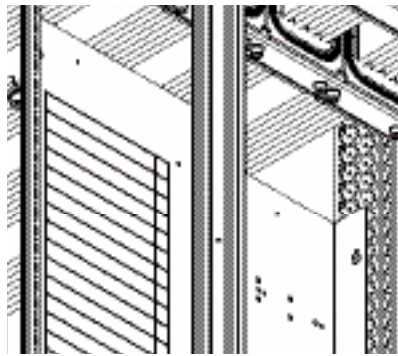

B 30.1.2.4

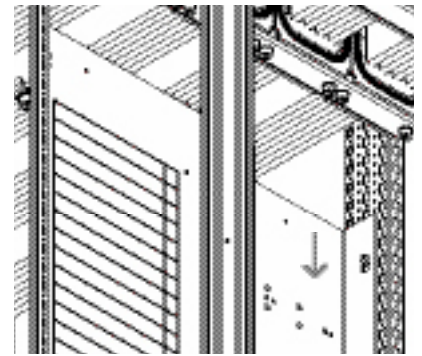

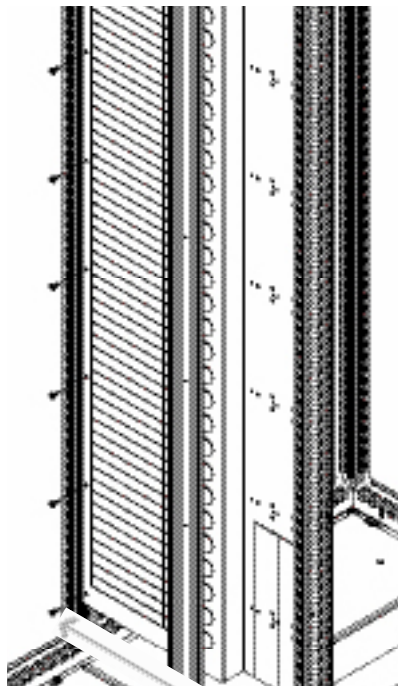

B 30.1.2.5

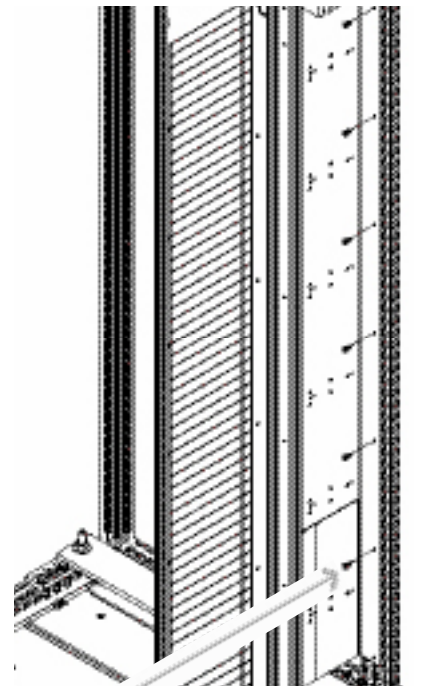

B 30.1.2.6



			
		T 25	5 Nm

Установка секционной стенки в панели с планочными разъединителями со сборными шинами сзади сверху

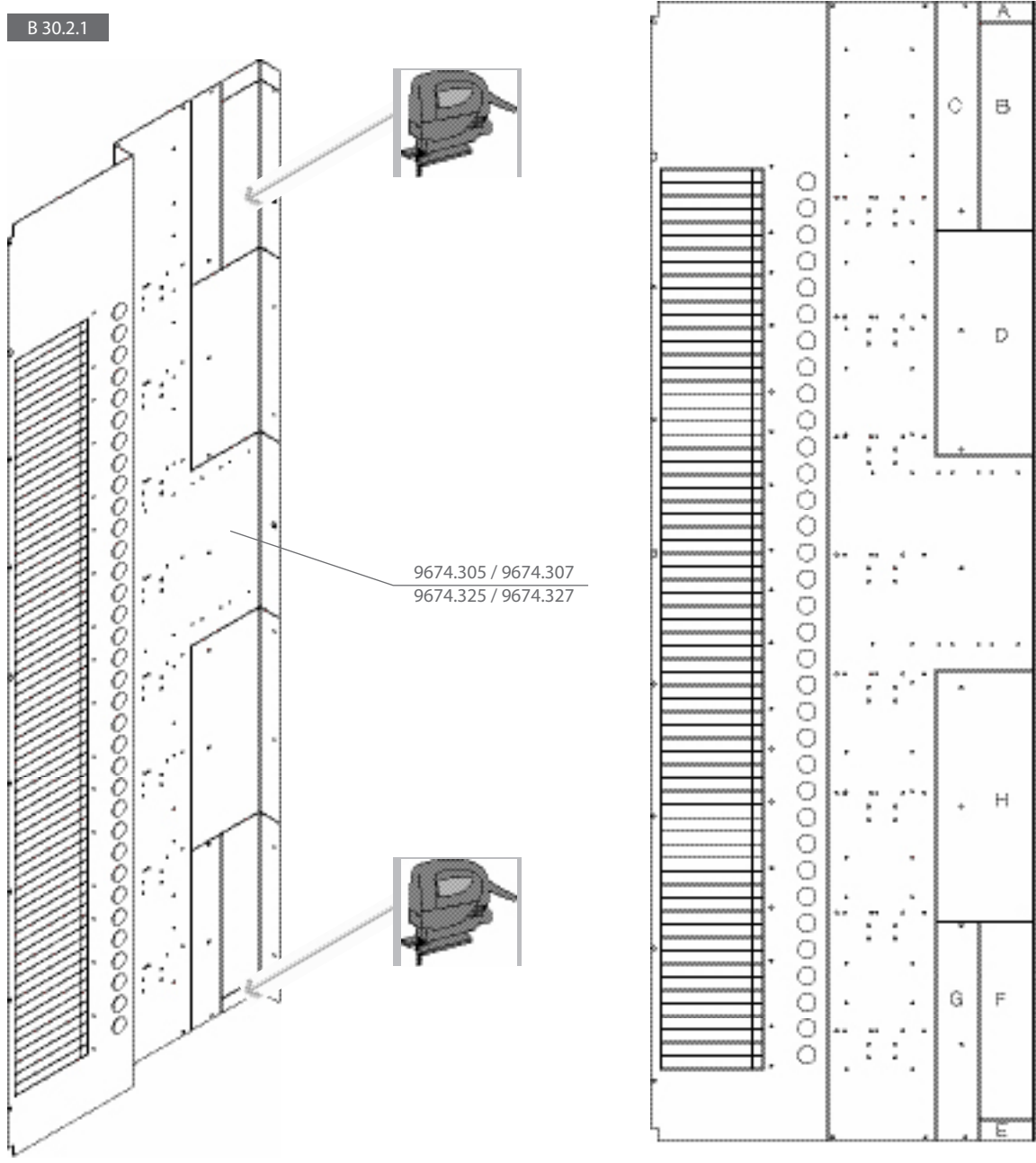

	A	B	C	D	E	F	G	H
Maxi-PLS 1600/2000 сзади сверху / in top rear section	X	X						
Maxi-PLS 1600/2000 сзади снизу / in bottom rear section					X	X		
Maxi-PLS 3200 сзади сверху / in top rear section	X	X	X	X				
Maxi-PLS 3200 сзади снизу / in bottom rear section					X	X	X	X
Flat-PLS 60 сзади сверху / in top rear section	X	X	X	X				
Flat-PLS 60 сзади снизу / in bottom rear section					X	X	X	X
Flat-PLS 100 сзади сверху / in top rear section	X	X	X	X				
Flat-PLS 100 сзади снизу / in bottom rear section					X	X	X	X
PE/PEN в области основания / in bottom area					X			
PE/PEN в области крыши / in roof area	X							
PE + N/PEN (Maxi-PLS) в области основания / in bottom area					X	X		
PE + N/PEN (Maxi-PLS) в области крыши / in roof area	X	X						
PE + N/PEN (Flat-PLS) в области основания / in bottom area					X	X	X	
PE + N/PEN (Flat-PLS) в области крыши / in roof area	X	X	X					

Установка секционной стенки в панели с планочными разъединителями со сборными шинами сзади сверху

B 30.2.2.1

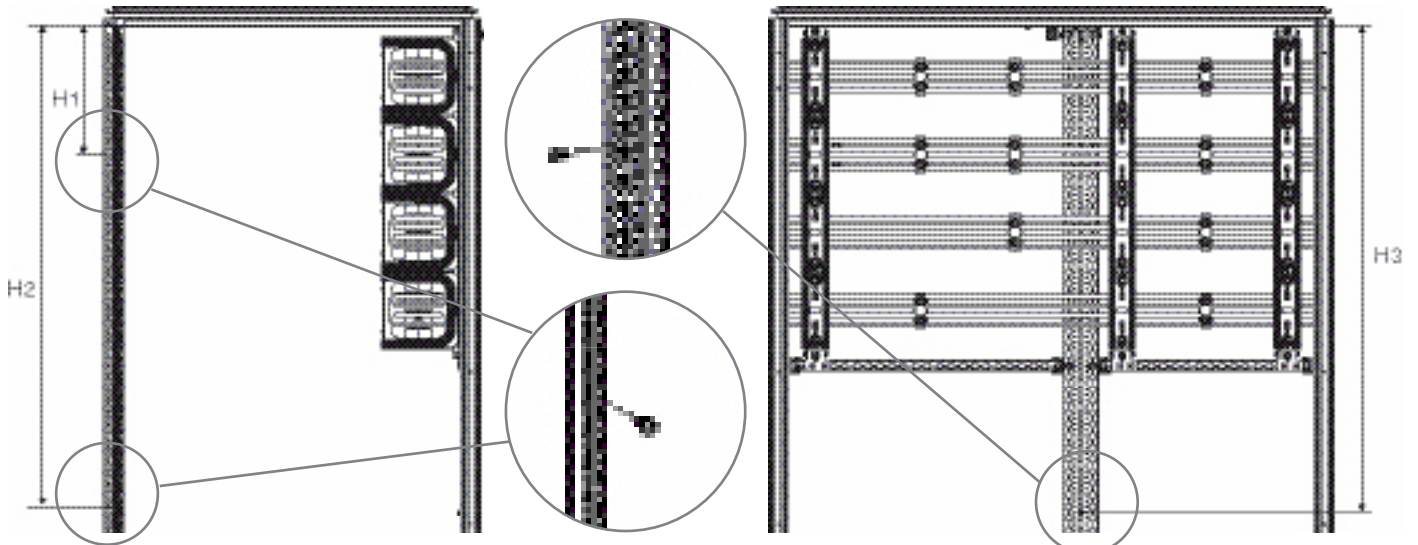

H	H1	H2	H3
2000 mm	68 mm	818 mm	831 mm
2200 mm	268 mm	1018 mm	1031 mm

B 30.2.2.3

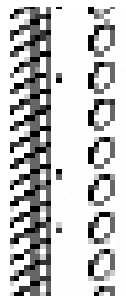

B 30.2.2.4

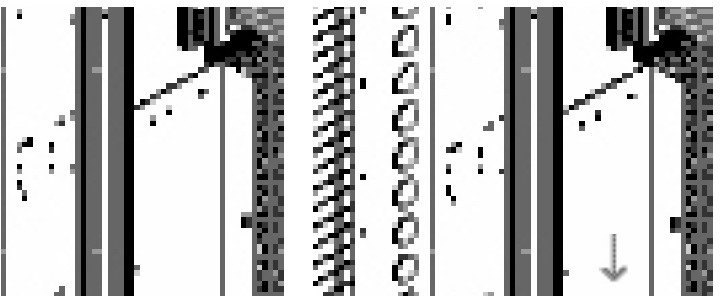

B 30.2.2.2

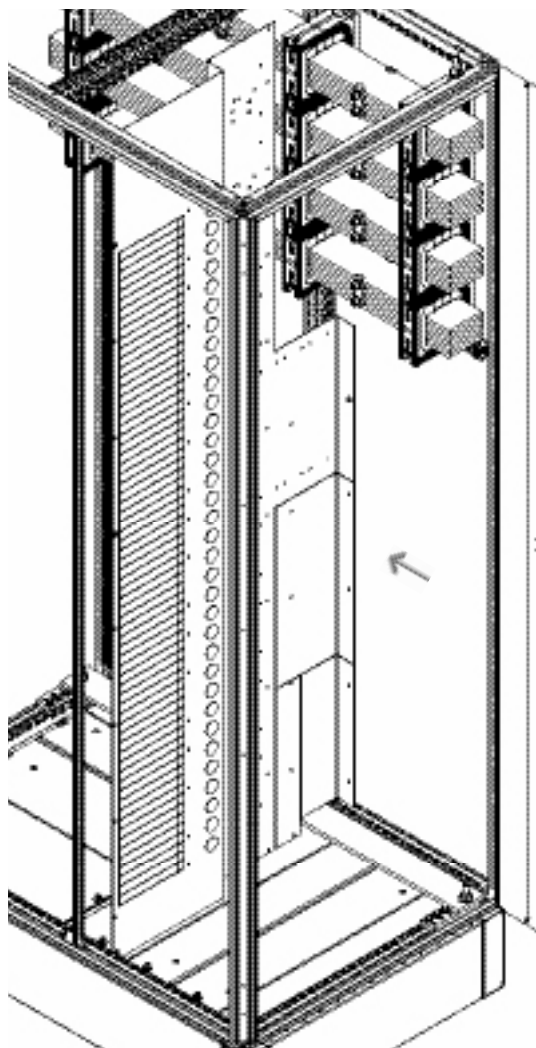

B 30.2.2.5

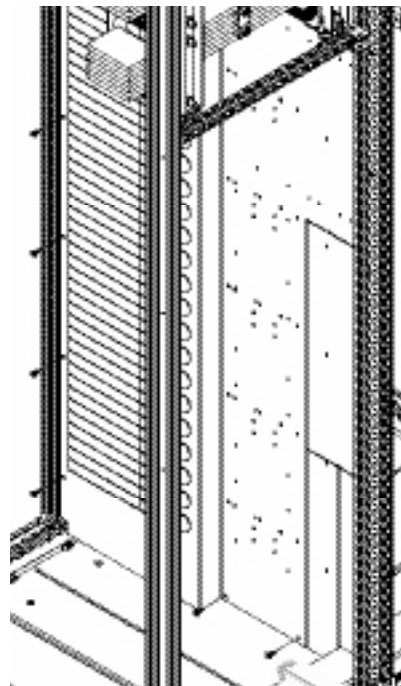

B 30.2.2.6

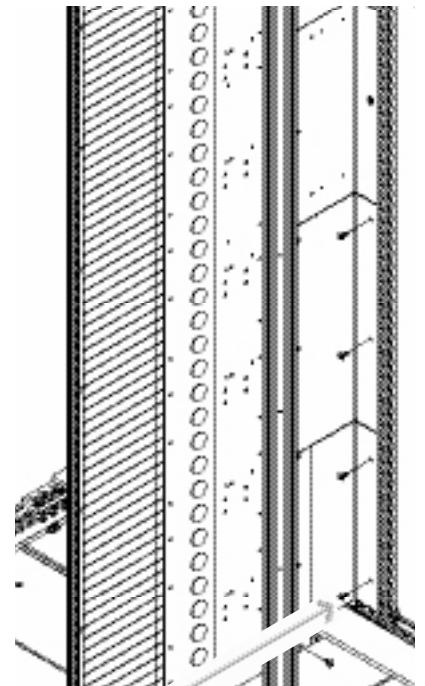

			
		T 25	5 Nm

Установка модульных секционных стенок в панели с планочными разъединителями Форма 1

Установка модульных секционных стенок в панели с планочными разъединителями Форма 1

В 31.1.1

В 31.2.1

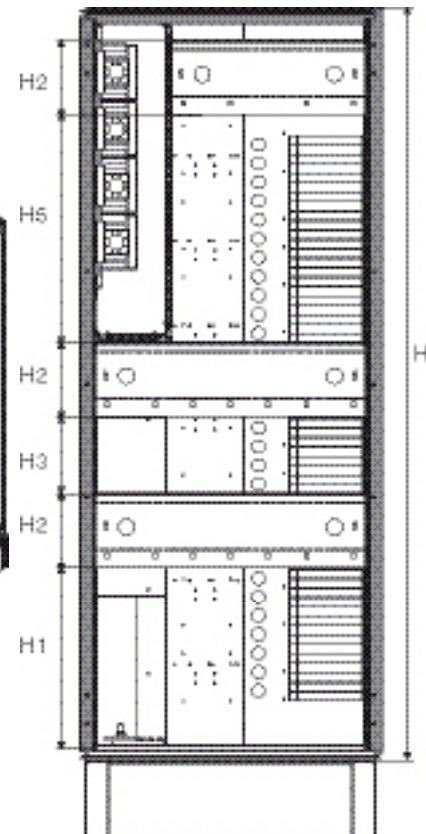
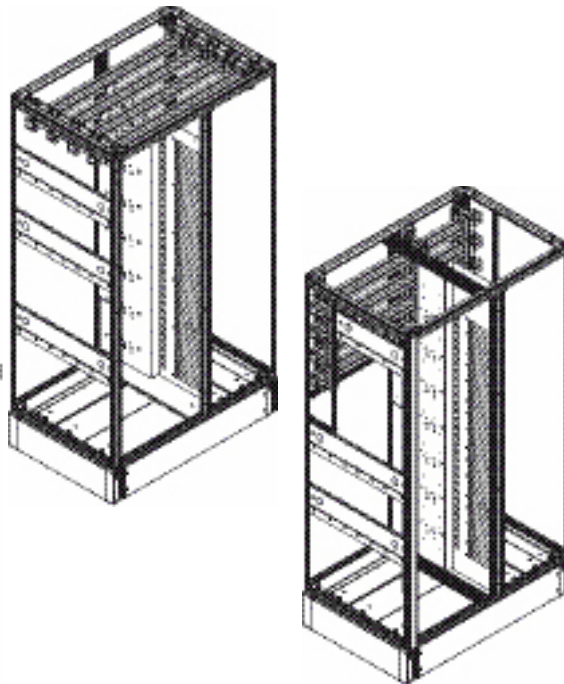
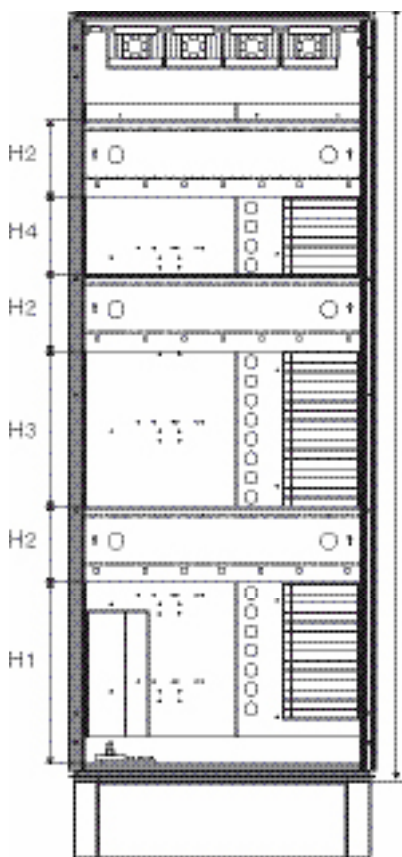

H	2000 mm	2200 mm
H 1	470 mm	470 mm
H 2	200 mm	200 mm
H 3	200 mm	400 mm
H 4	400 mm	400 mm
H 5	600 mm	600 mm

В 31.3.1

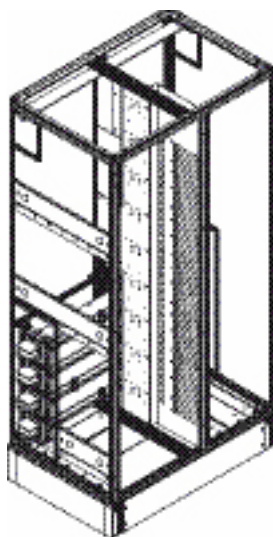
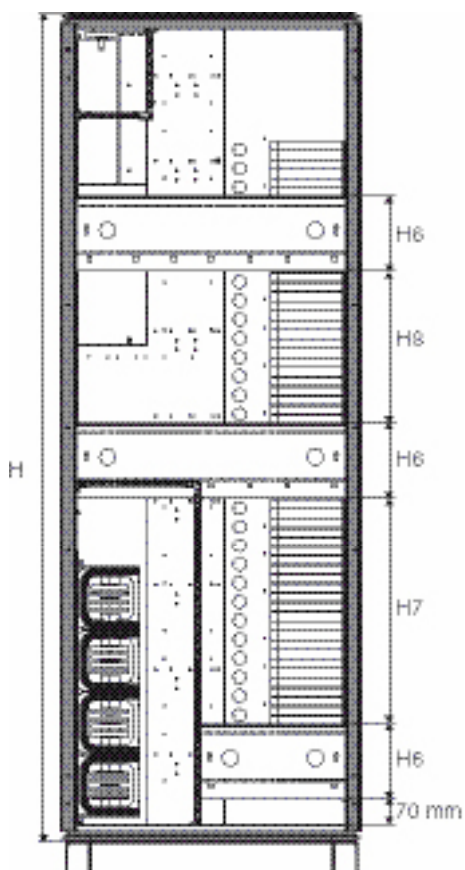

H	2000 mm	2200 mm
H 6	200 mm	200 mm
H 7	600 mm	600 mm
H 8	200 mm	400 mm

Установка модульных секционных стенок в панели с планочными разъединителями Форма 2-4

В 31.1.2



В 31.2.2

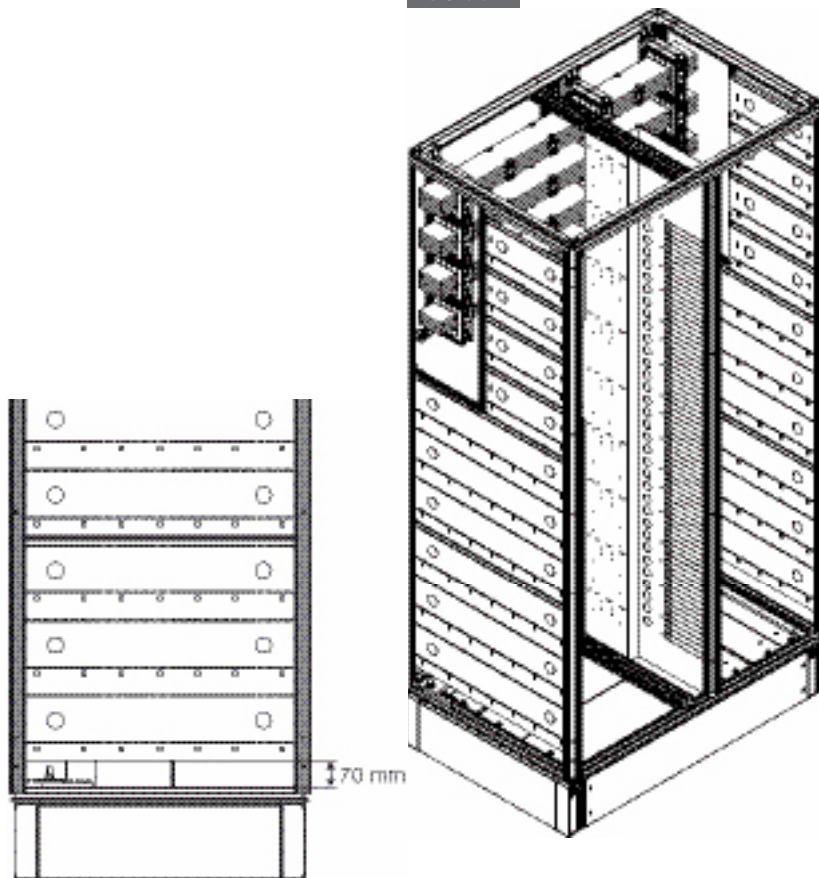

В 31.3.2

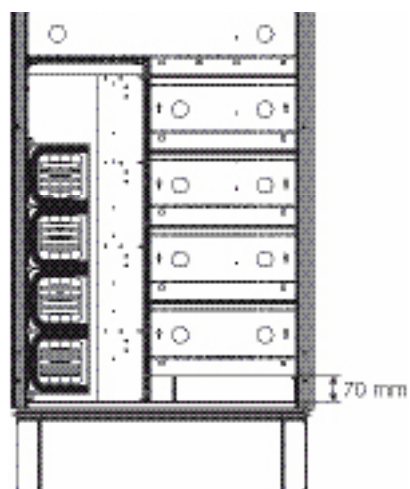
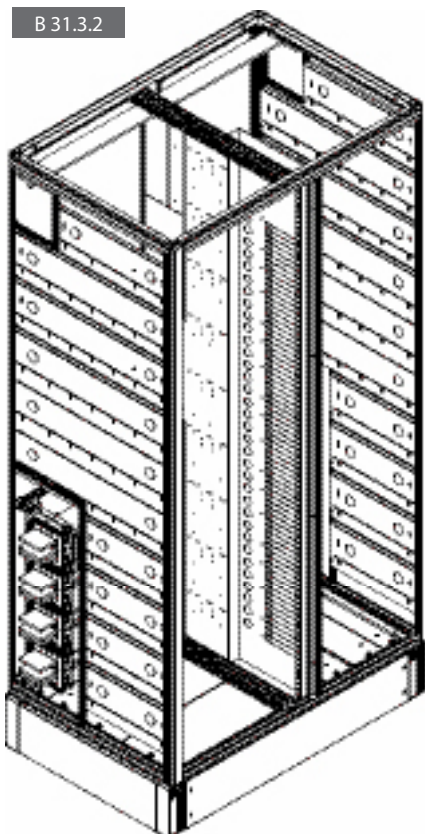

Установка модульных секционных стенок в панели с планочными разъединителями

Установка модульных частичных стенок Assembling of the side panel modules in the switch disconnecter fuse section

B 31.4.1

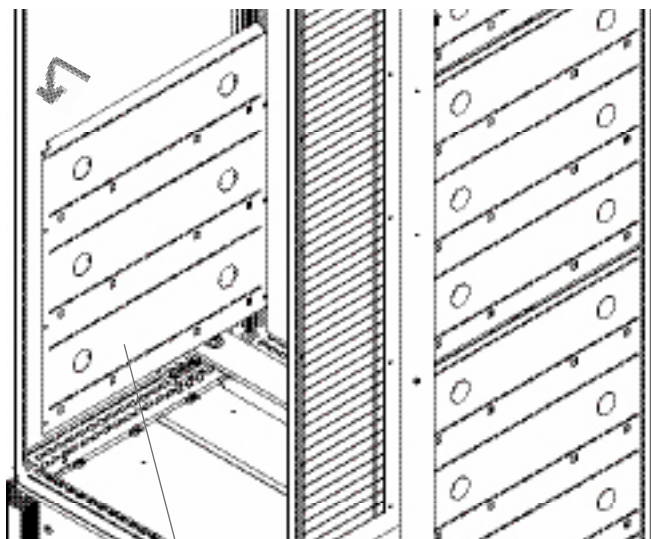

B 31.4.2

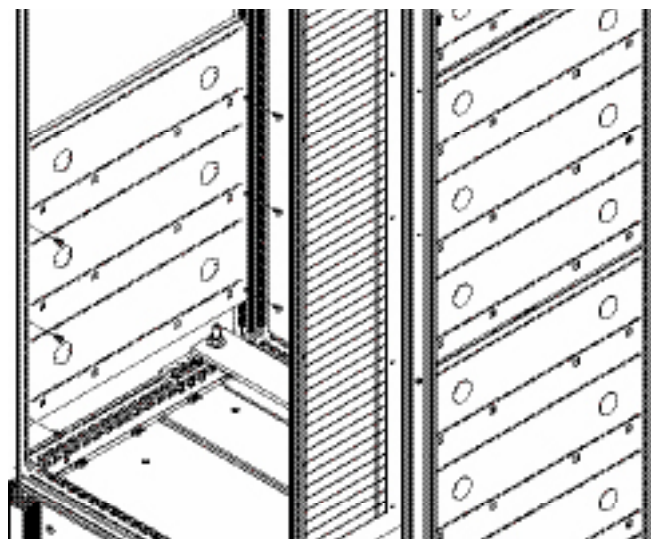

9673.051 – 9673.086

B 31.4.3

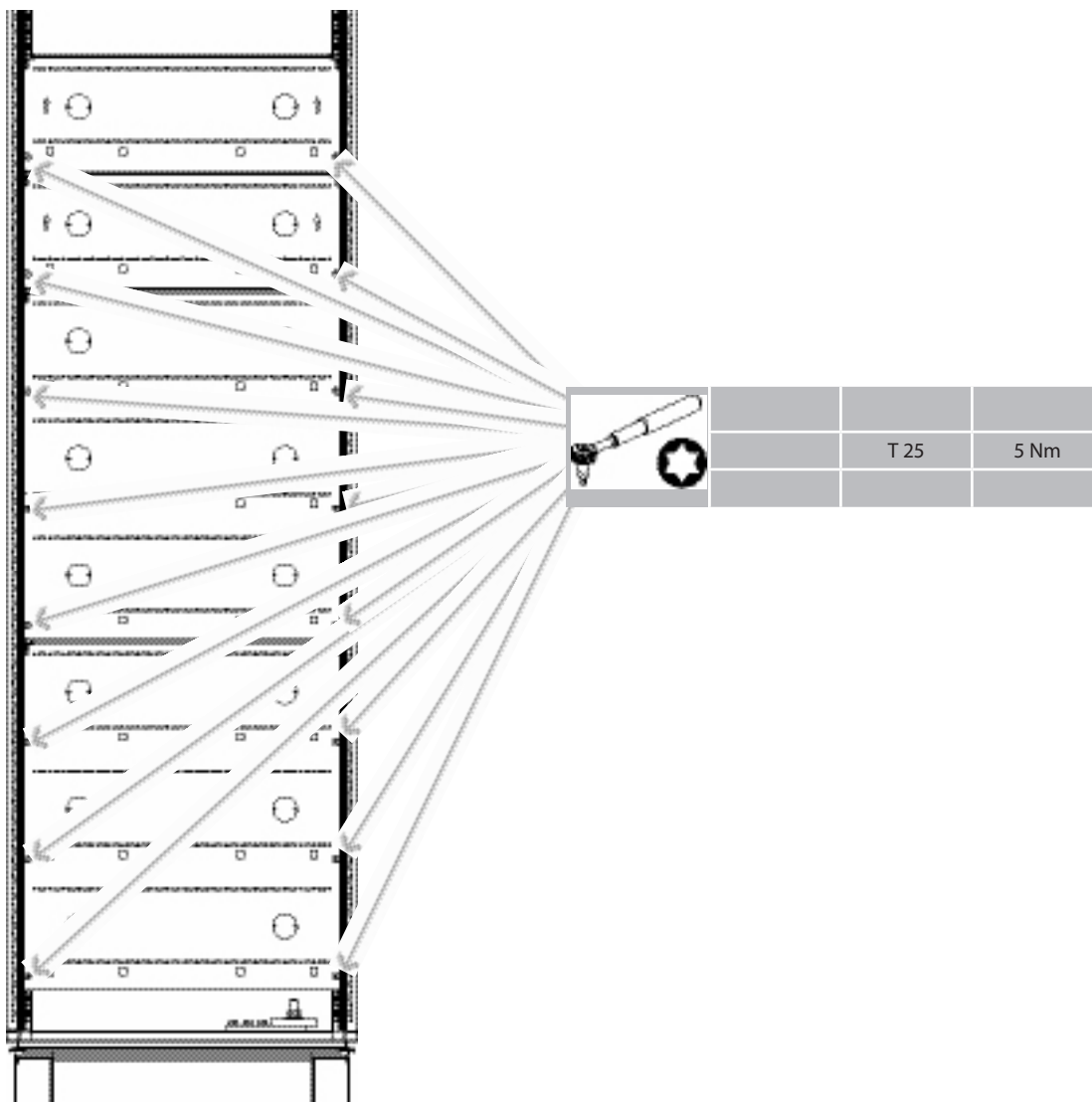

Установка монтажного комплекта в панели с планочными разъединителями

Установка монтажного комплекта Assembling the kit for switch-disconnector-fuse section

B 32.1.1.1

Jean Müller

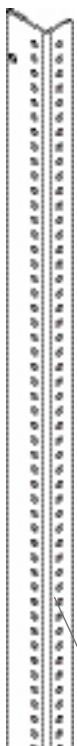

H	
2000 mm	9674.350
2200 mm	9674.352

B 32.1.1.2

ABB/Siemens



H	
2000 mm	9674.356
2200 mm	9674.358

B 32.1.2

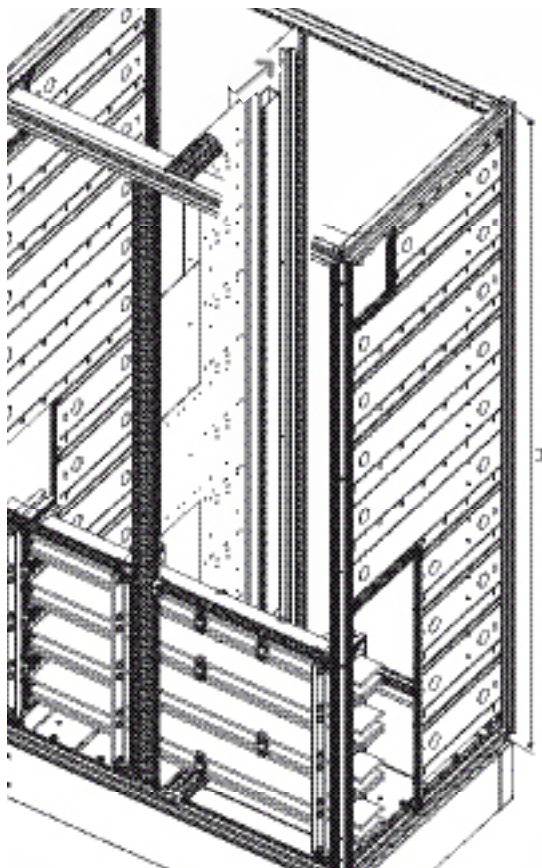

B 32.1.3

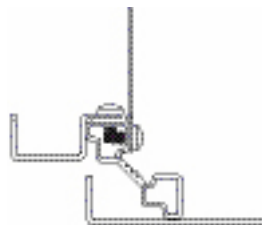
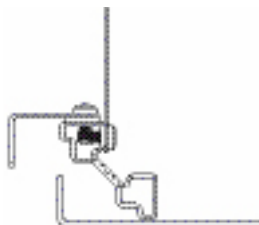
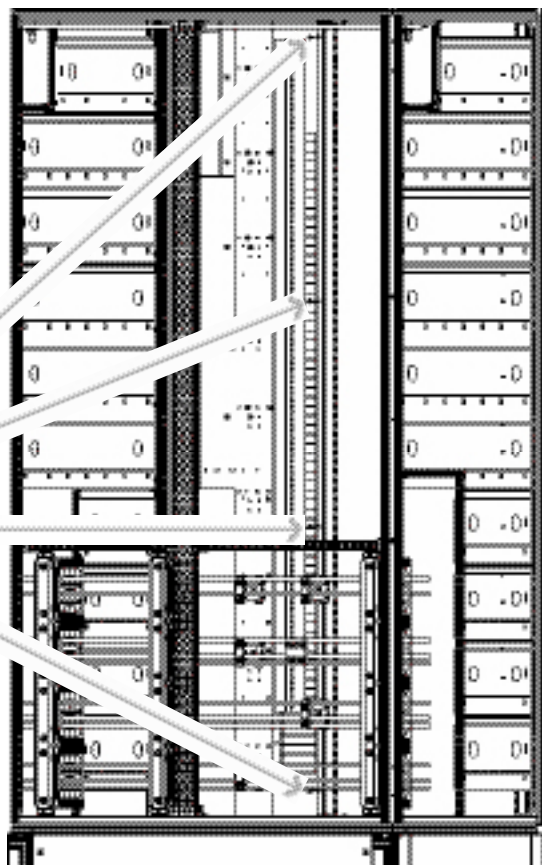

T 25	5 Nm
------	------

Установка монтажного комплекта в панели с планочными разъединителями

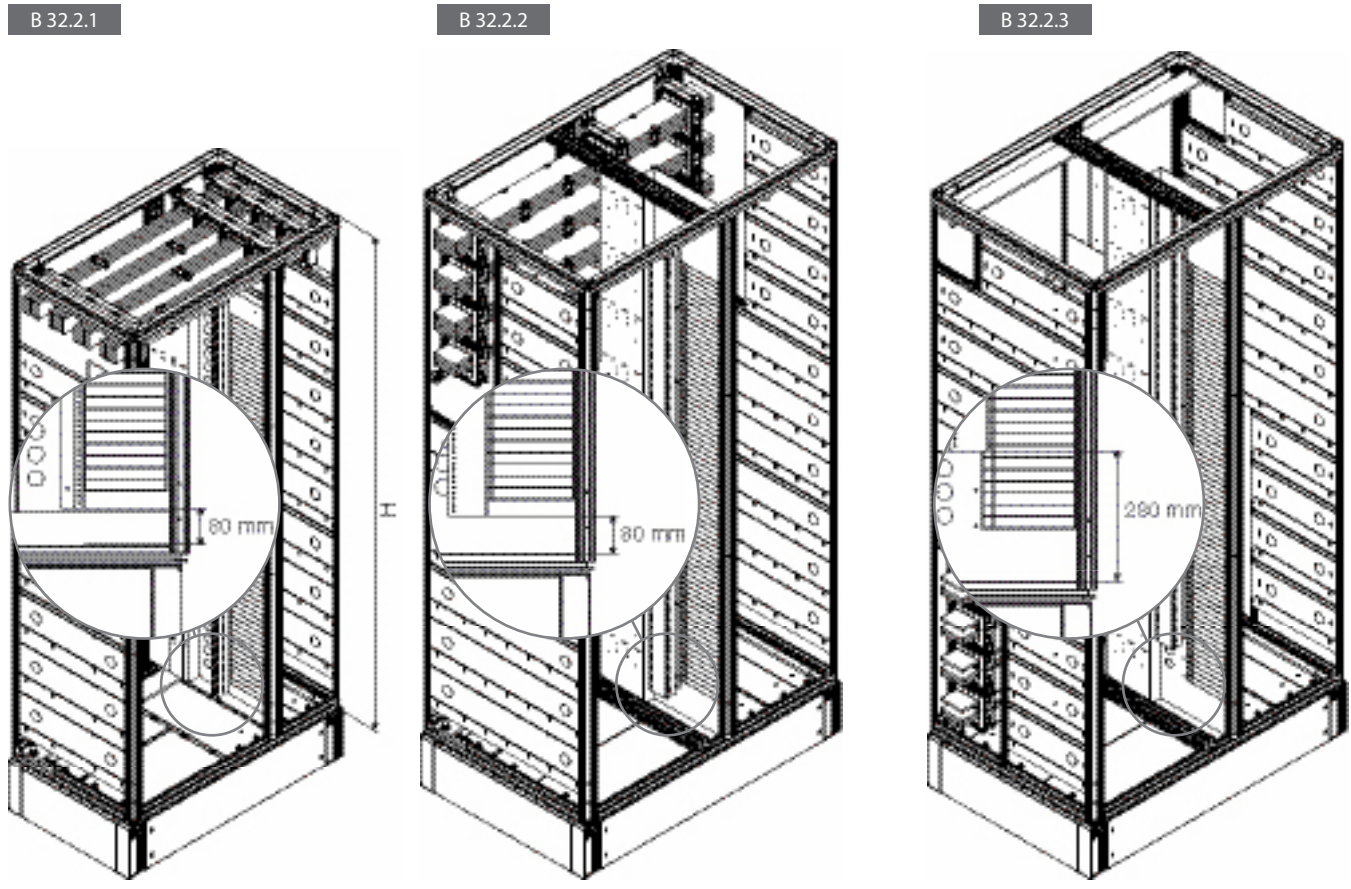

B 32.2.2.1 Jean Müller

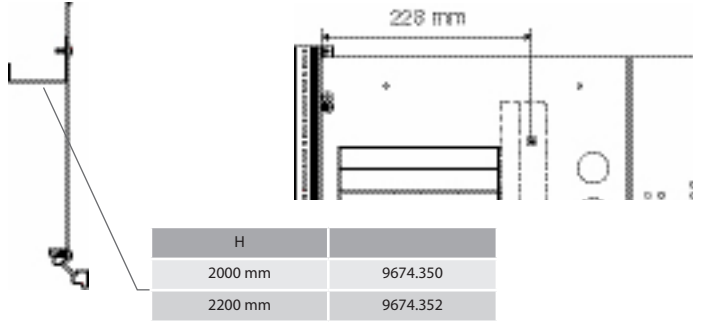

B 32.2.2.2 ABB/Siemens

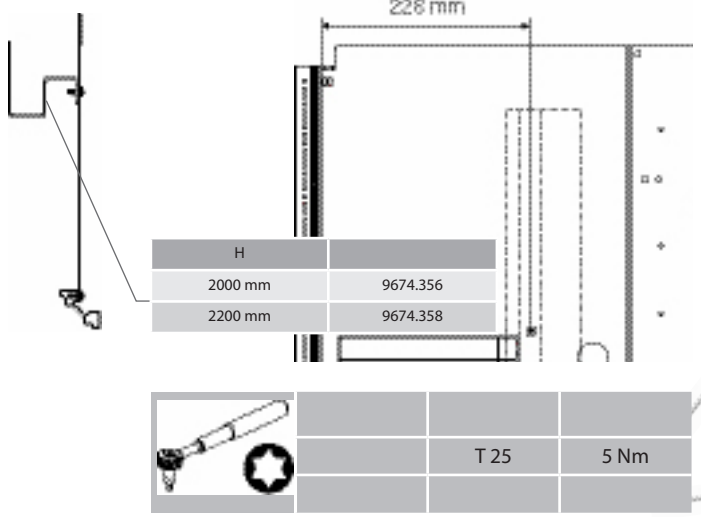

B 32.2.3.1

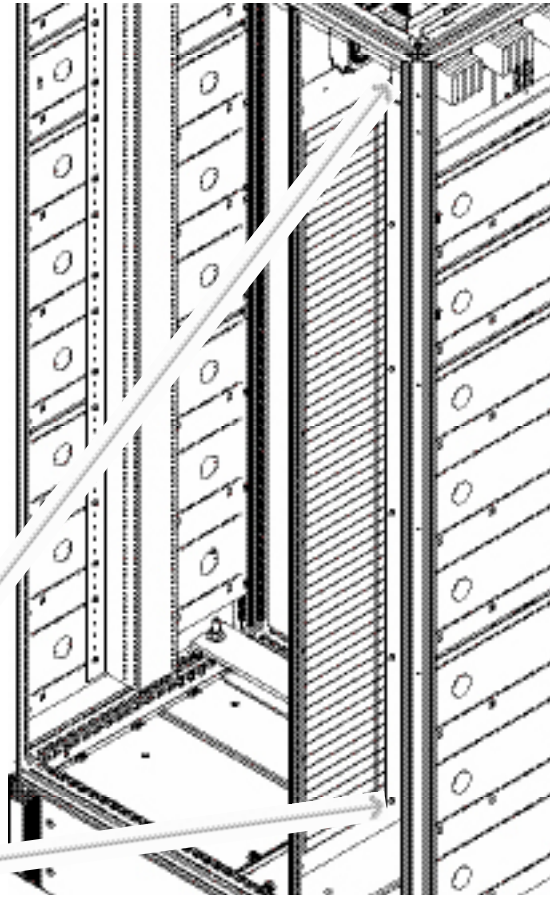

Установка монтажного комплекта в панели с планочными разъединителями

Установка монтажного комплекта Assembling the kit for switch-disconnector-fuse section

B 32.3.1.1

Jean Müller

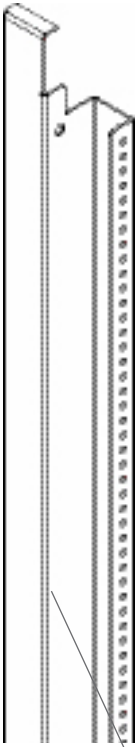

Н	
2000 mm	9674.350
2200 mm	9674.352

B 32.3.1.2

ABB/Siemens

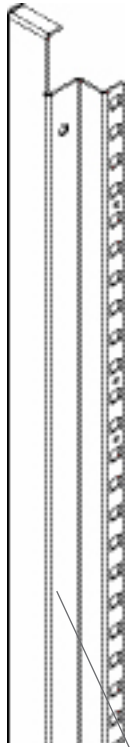

Н	
2000 mm	9674.356
2200 mm	9674.358

B 32.3.2

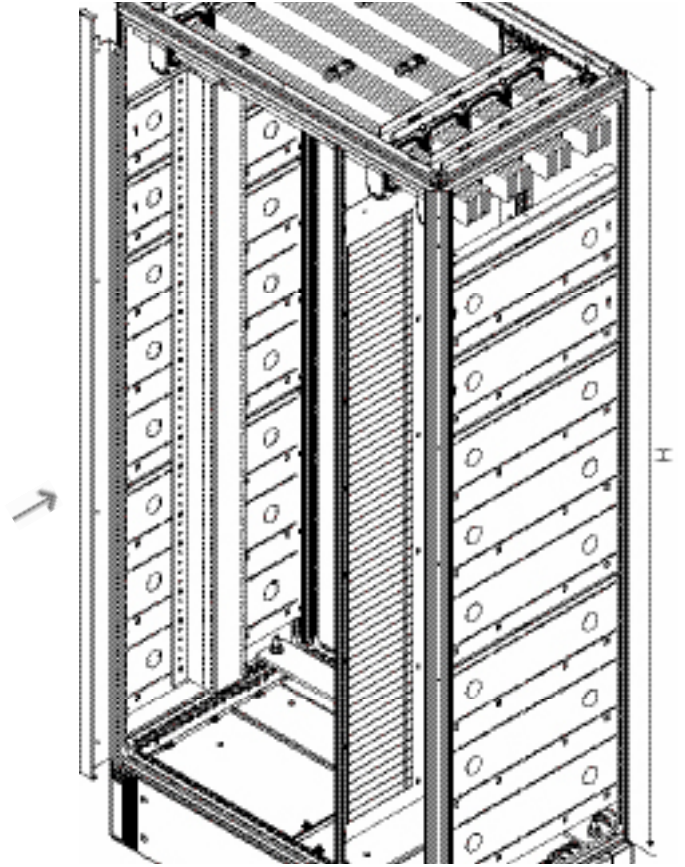

B 32.3.3

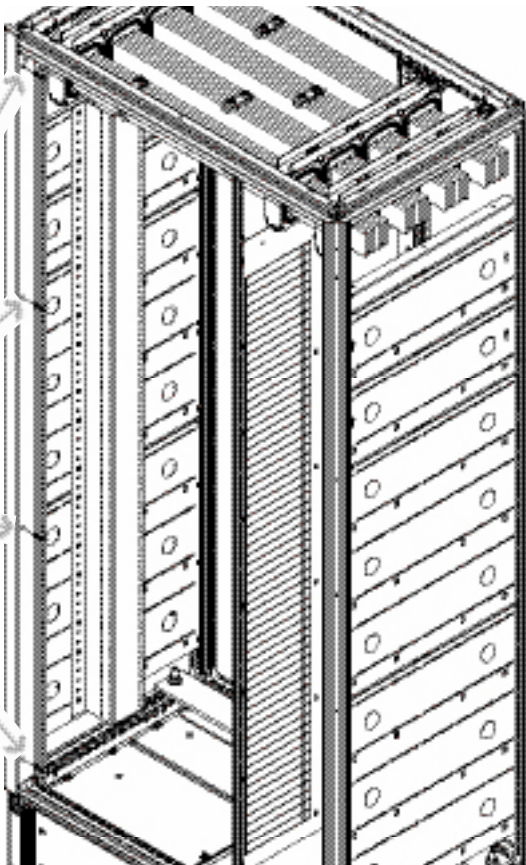

		T 25	5 Nm
--	--	------	------

Установка монтажного комплекта в панели с планочными разъединителями

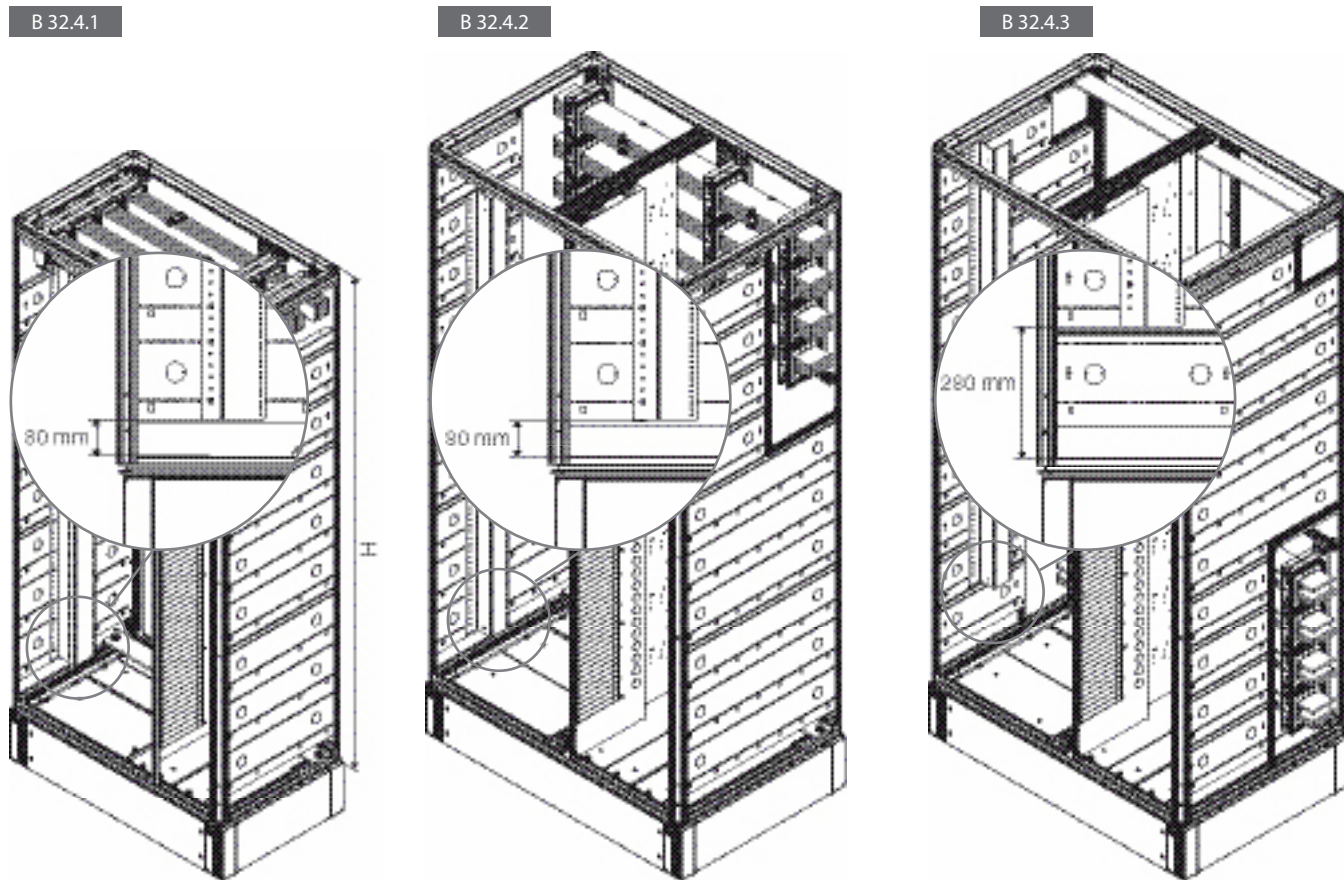

B 32.4.2.1 Jean Müller

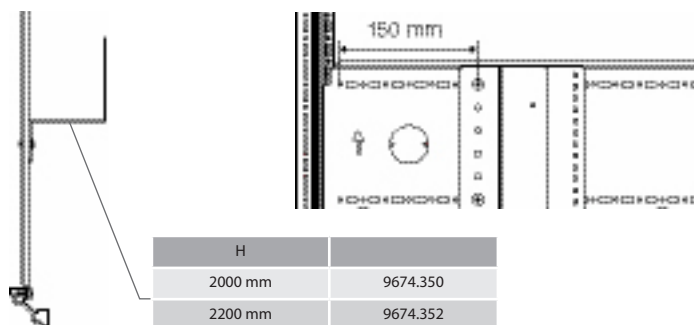

B 32.4.2.2 ABB/Siemens

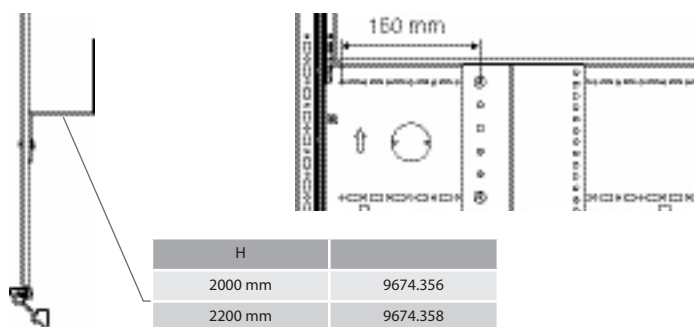

		T 25	5 Nm
--	--	------	------

B 32.4.3.1

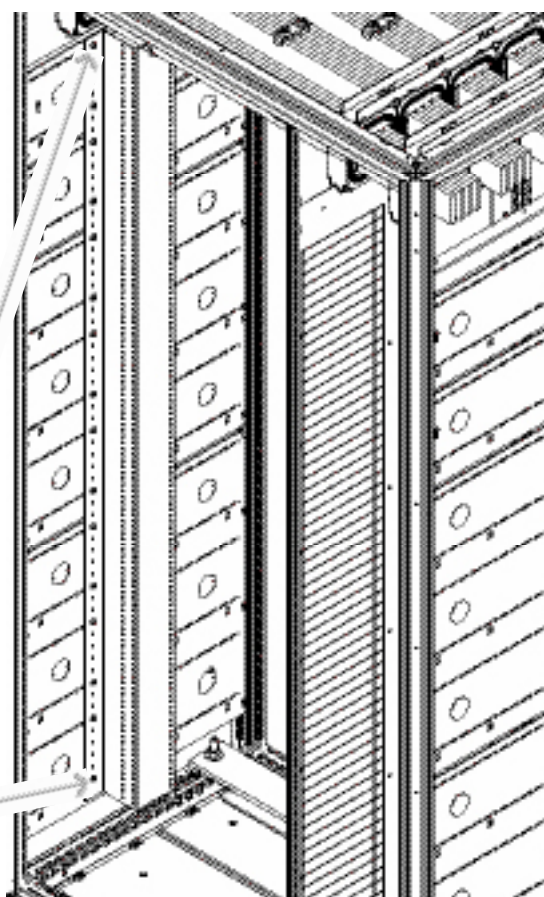

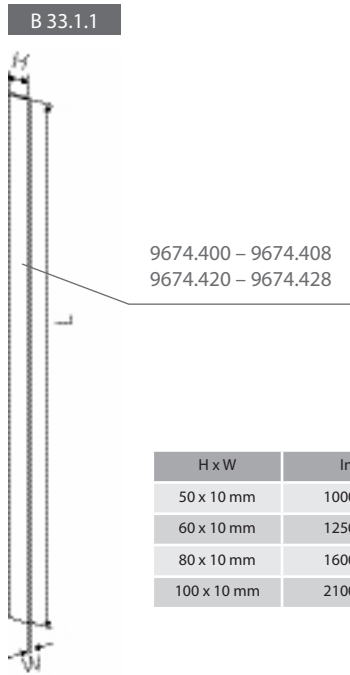

Установка распределительных шин в панели с планочными разъединителями со сборными шинами сверху/сзади сверху

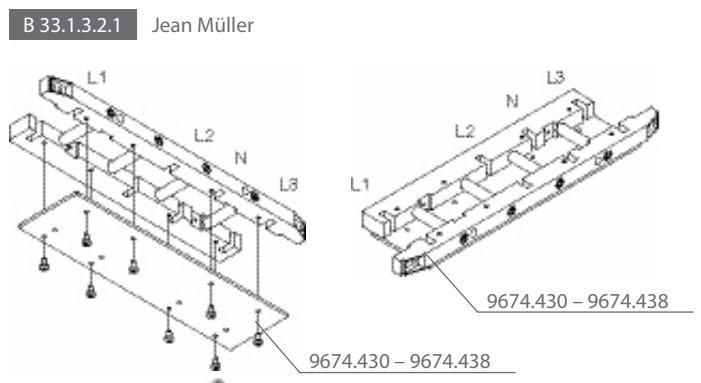
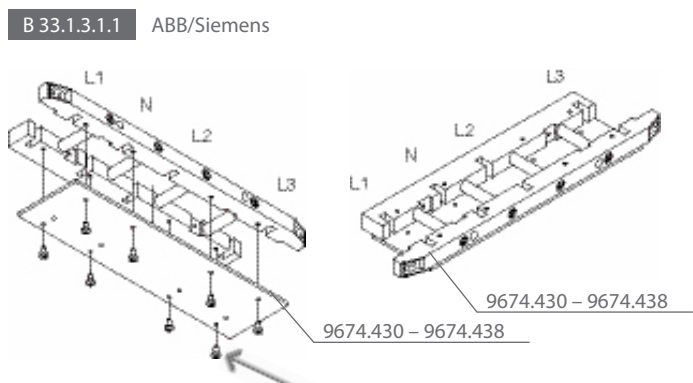
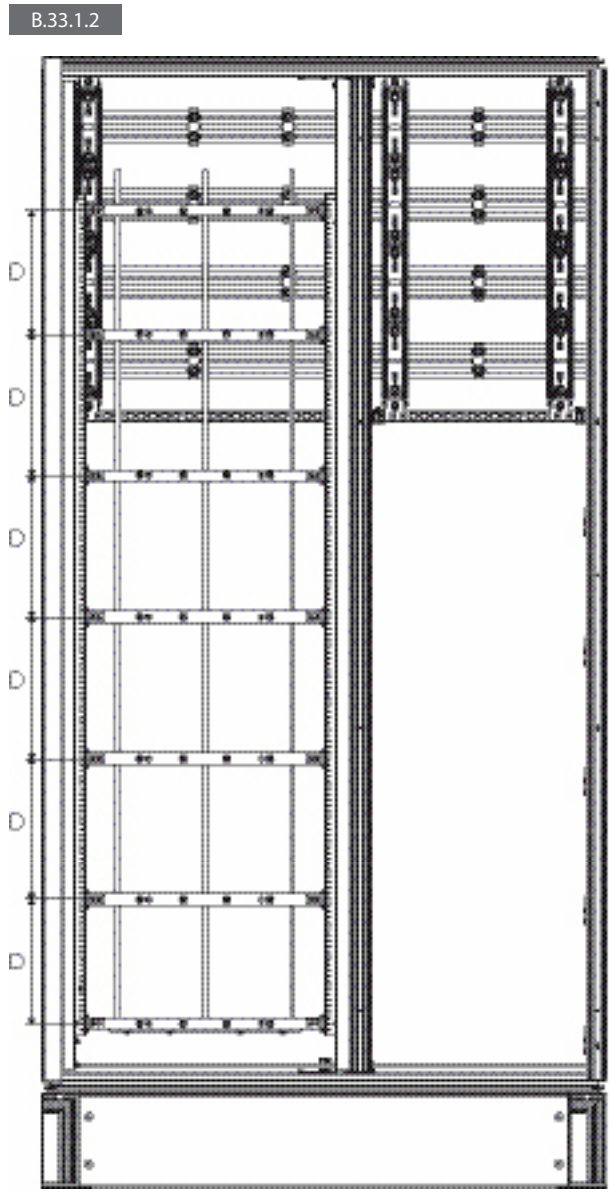

H x W	In
50 x 10 mm	1000 A
60 x 10 mm	1250 A
80 x 10 mm	1600 A
100 x 10 mm	2100 A

H x W	Icw	D max.
50 x 10 mm	50 kA 1sec	500 mm
	70 kA 1sec	275 mm
60 x 10 mm	50 kA 1sec	500 mm
	75 kA 1sec	275 mm
80 x 10 mm	60 kA 1sec	500 mm
	85 kA 1sec	275 mm
100 x 10 mm	70 kA 1sec	500 mm
	100 kA 1sec	275 mm





PH 2
1,5 Nm

Установка распределительных шин в панели с планочными разъединителями со сборными шинами сверху/сзади сверху

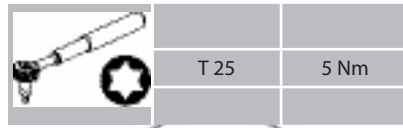
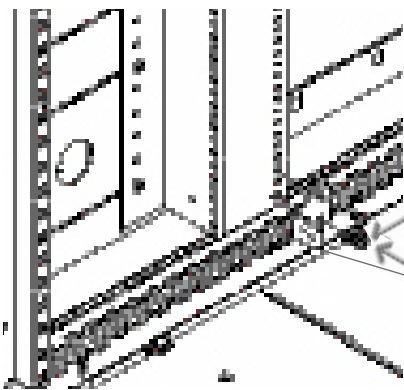
B 33.1.4.1.1 ABB/Siemens

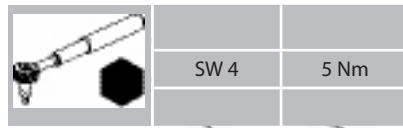
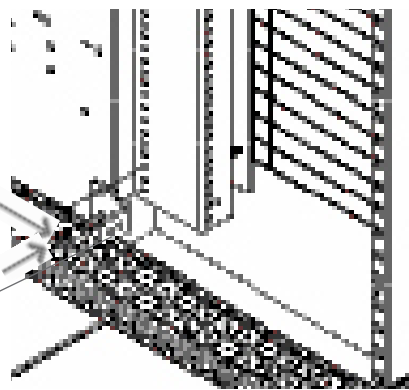

B 33.1.4.1.2



9674.430 – 9674.438

B 33.1.4.1.3

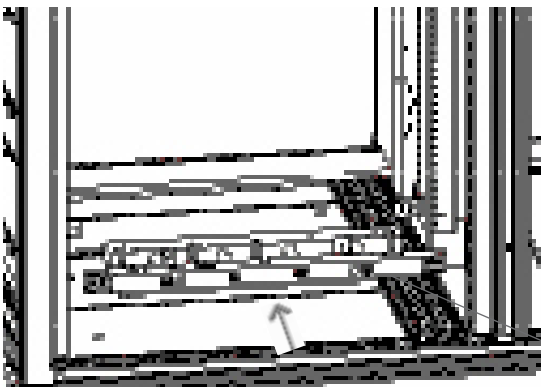

B 33.1.4.1.4

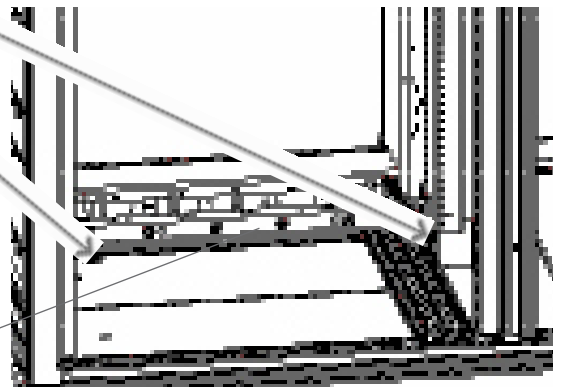

9674.430 – 9674.438

B 33.1.4.2.1 Jean Müller

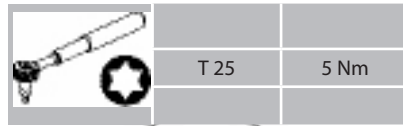
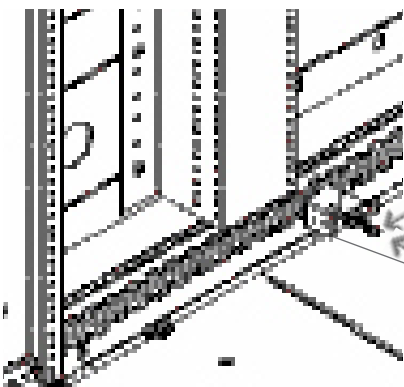

B 33.1.4.2.2

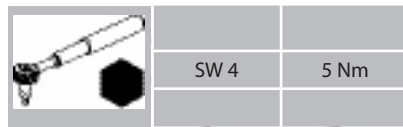
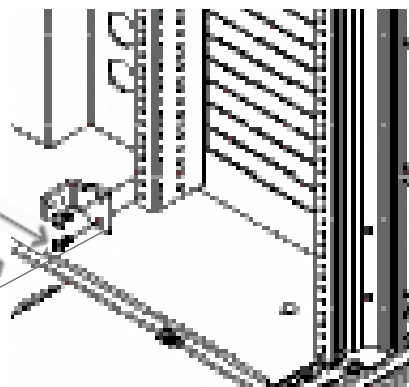

9674.430 – 9674.438

B 33.1.4.2.3

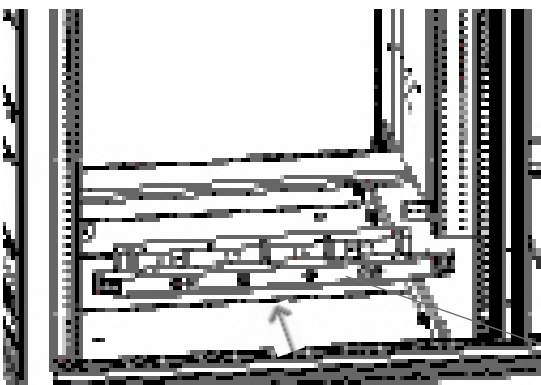

B 33.1.4.2.4

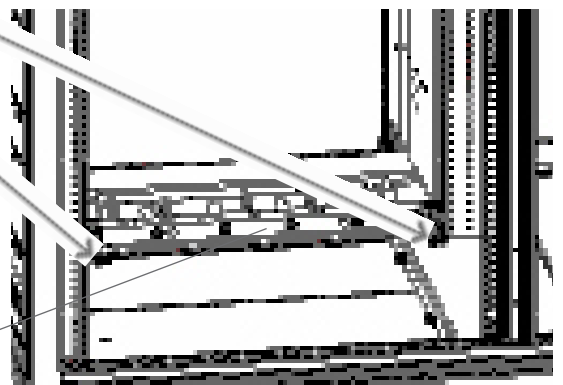

9674.430 – 9674.438

Установка распределительных шин в панели с планочными разъединителями со сборными шинами сверху/сзади сверху

B 33.1.5.1.1 ABB/Siemens

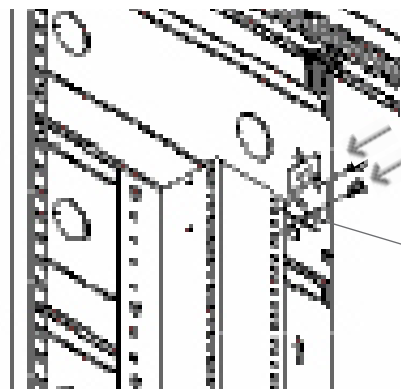

	T 25	5 Nm
---	------	------

B 33.1.5.1.2

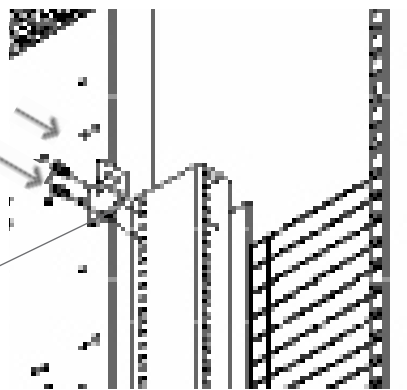

9674.410 – 9674.418

B 33.1.5.1.3

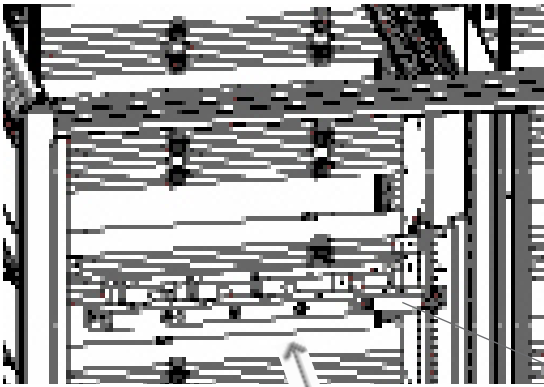

	SW 4	5 Nm
---	------	------

B 33.1.5.1.4

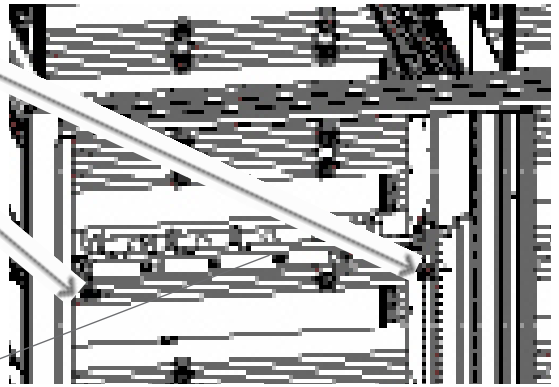

9674.410 – 9674.418

B 33.1.5.2.1 Jean Müller

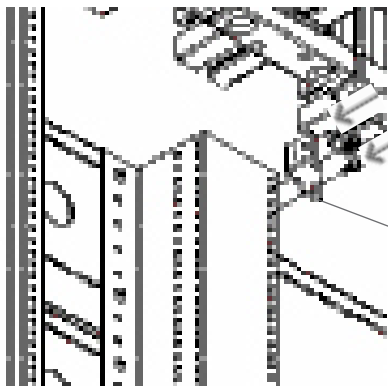

	T 25	5 Nm
---	------	------

B 33.1.5.2.2

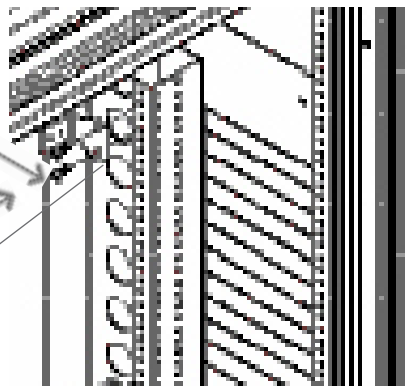

9674.410 – 9674.418

B 33.1.5.2.3

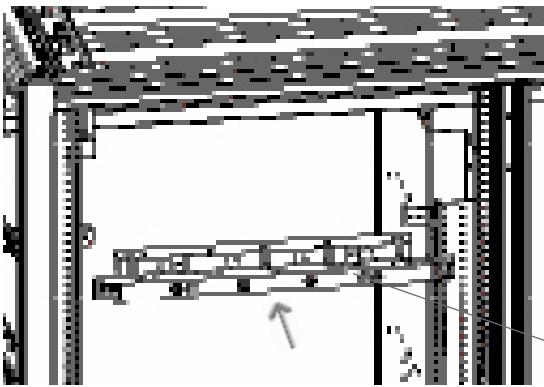

	SW 4	5 Nm
---	------	------

B 33.1.5.2.4

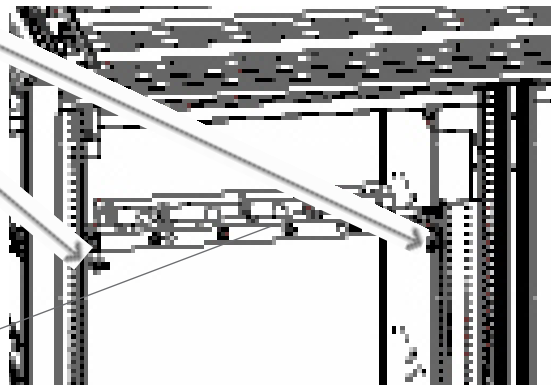

9674.410 – 9674.418

Установка распределительных шин в панели с планочными разъединителями со сборными шинами сверху/сзади сверху

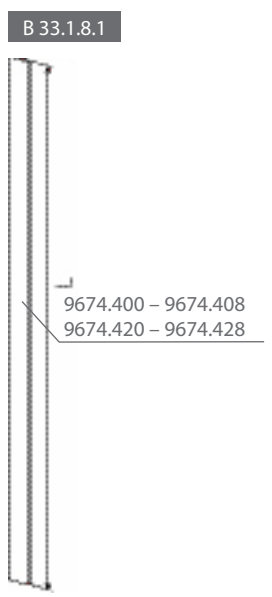
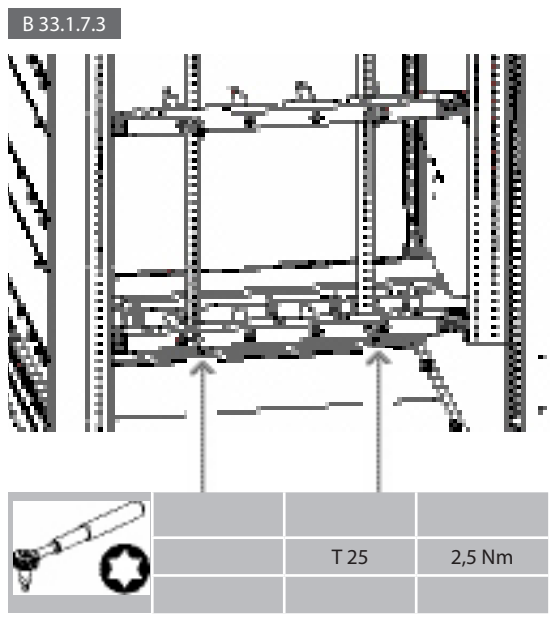
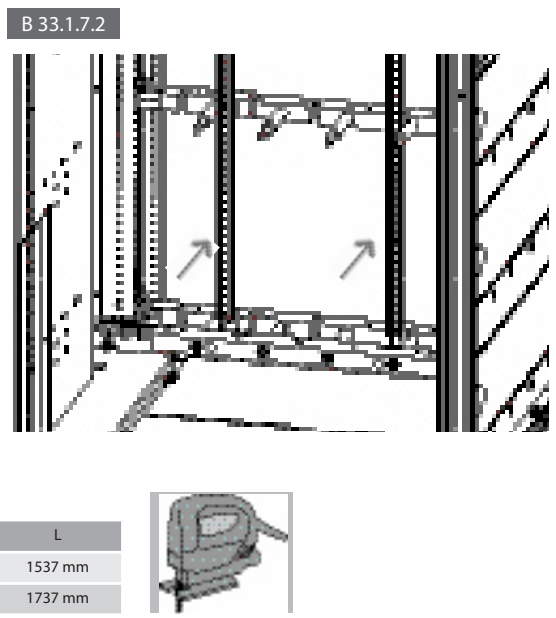
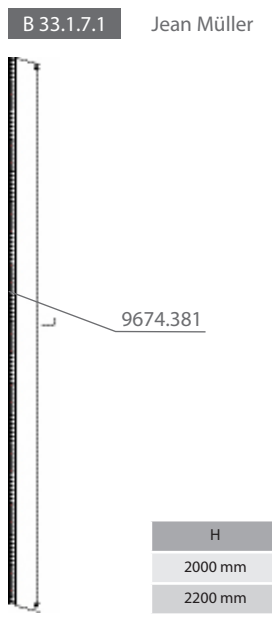
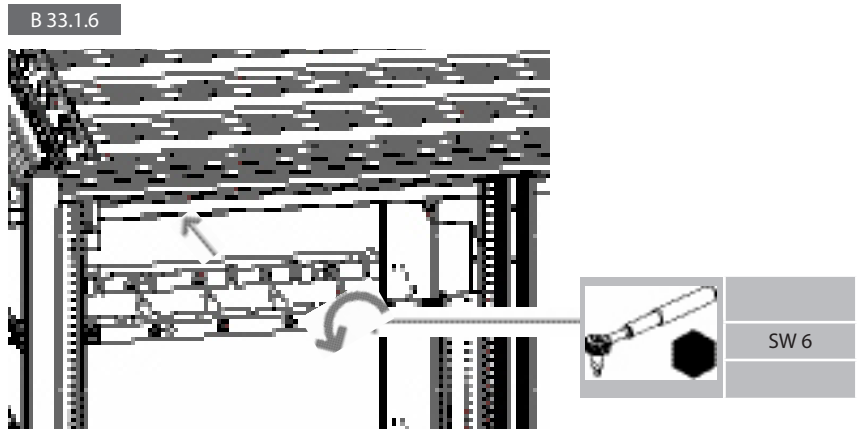

	H = 2000mm	H = 2200mm
Hauptschienensystem im Dachbereich main busbar system in roof area	L	L
Maxi-PLS 1600/2000	1633 mm	1833 mm
Maxi-PLS 3200	1618 mm	1818 mm
Flat-PLS 60	1618 mm	1818 mm
Flat-PLS 100	1593 mm	1793 mm
	H = 2000mm	H = 2200mm
Hauptschienensystem im Rückbereich oben main busbar system in rear top position	L	L
Maxi-PLS 1600/2000	1623 mm	1823 mm
Maxi-PLS 3200	1623 mm	1823 mm
Flat-PLS 60	1623 mm	1823 mm
Flat-PLS 100	1623 mm	1823 mm

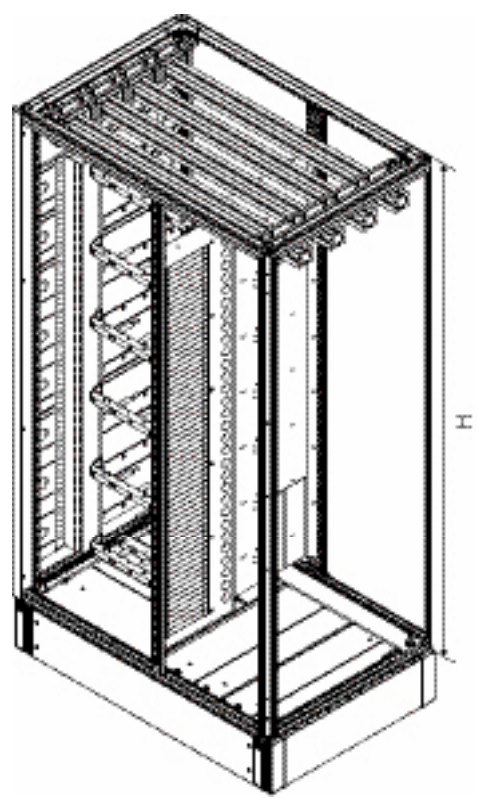

Установка распределительных шин в панели с планочными разъединителями со сборными шинами сверху/сзади сверху

Установка распределительных шин в панели с разъединителями Assembling the distribution busbar system

B 33.1.8.2

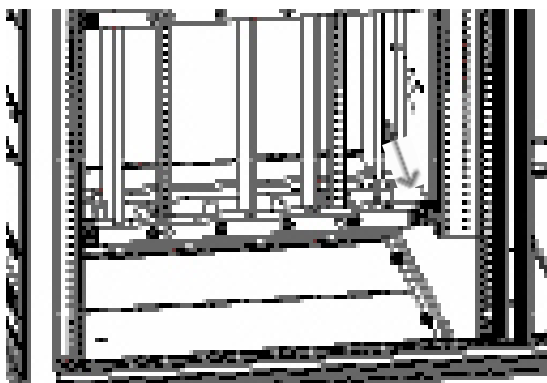

B 33.1.8.3

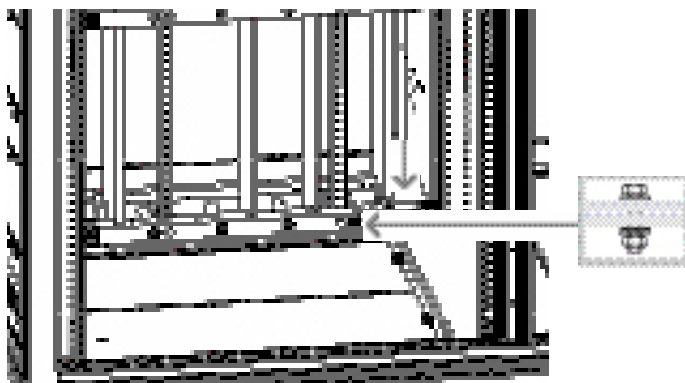

B 33.1.8.4

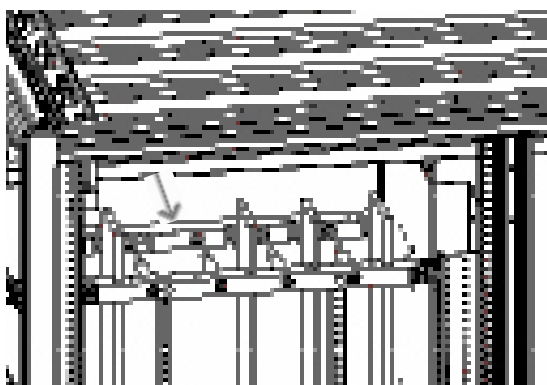

B 33.1.8.5

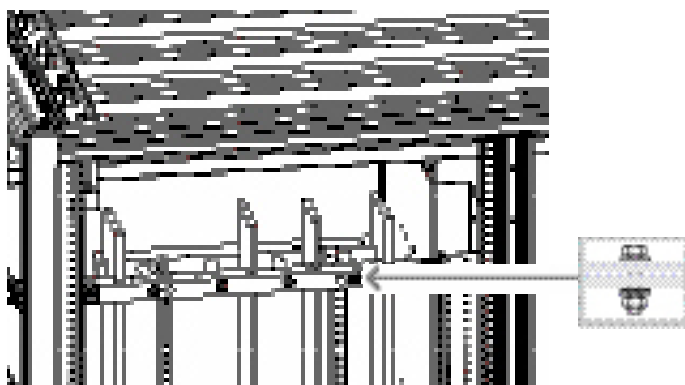

B 33.1.8.6

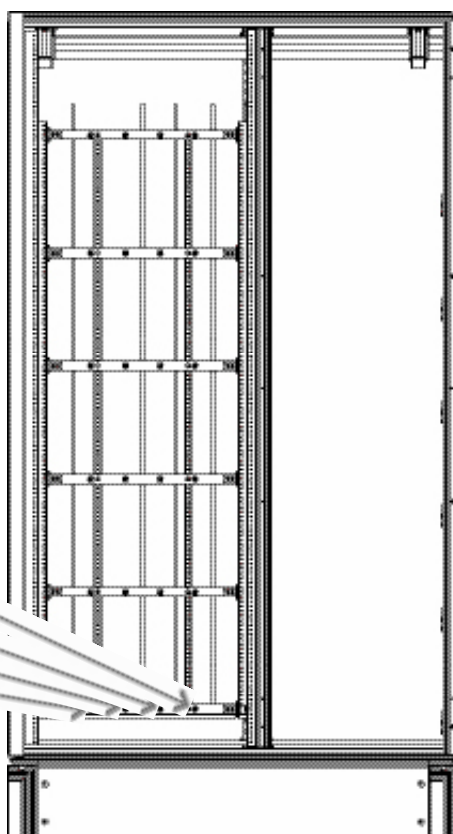

SW 6

5 Nm

Установка распределительных шин в панели с планочными разъединителями со сборными шинами сзади снизу

B 33.2.1

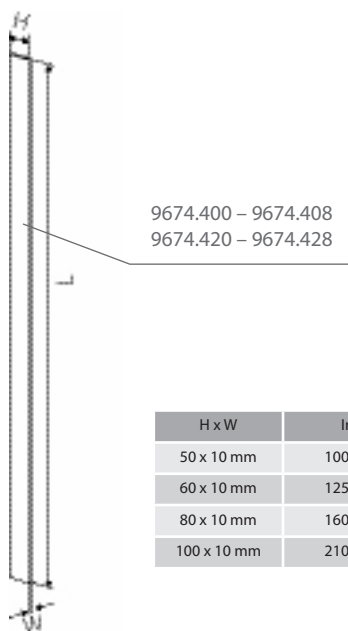

H x W	In
50 x 10 mm	1000 A
60 x 10 mm	1250 A
80 x 10 mm	1600 A
100 x 10 mm	2100 A

H x W	Icw	D max.
50 x 10 mm	50 kA 1sec	500 mm
	70 kA 1sec	275 mm
60 x 10 mm	50 kA 1sec	500 mm
	75 kA 1sec	275 mm
80 x 10 mm	60 kA 1sec	500 mm
	85 kA 1sec	275 mm
100 x 10 mm	70 kA 1sec	500 mm
	100 kA 1sec	275 mm

B.33.2.2

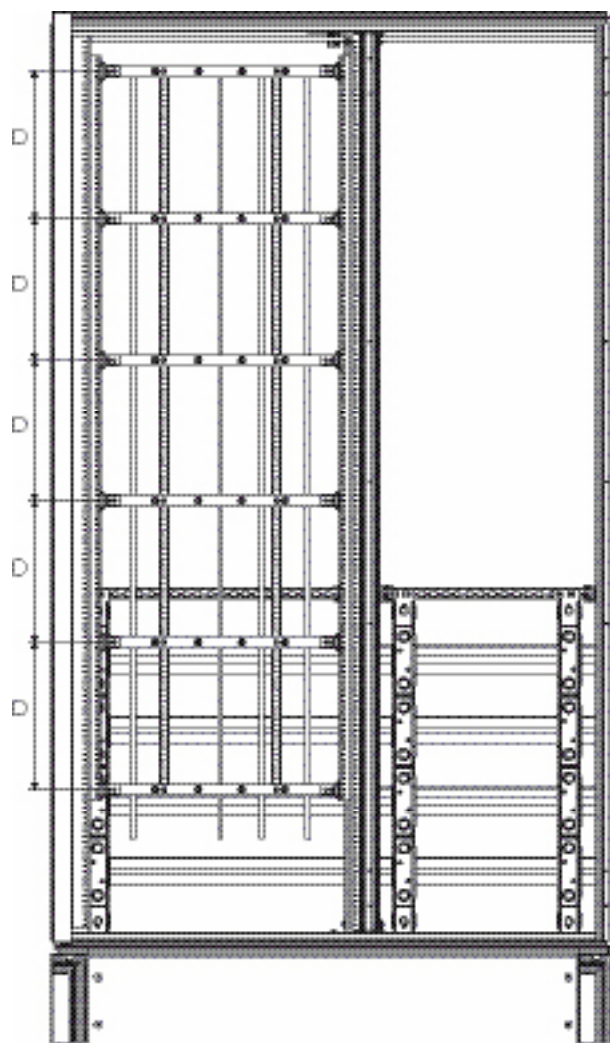

B 33.2.3.1.1 ABB/Siemens

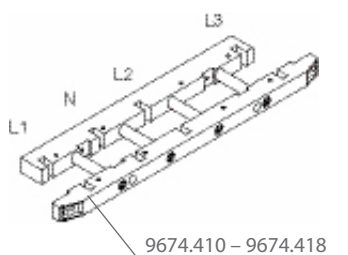

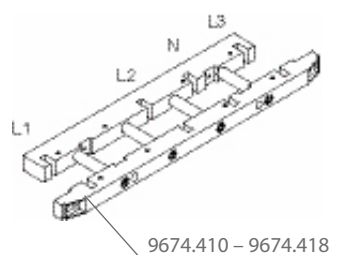

B 33.2.3.2.1 Jean Müller

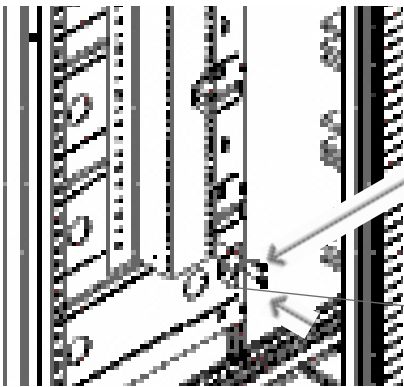

Установка распределительных шин в панели с планочными разъединителями со сборными шинами сзади снизу

B 33.2.4.1.1 ABB/Siemens



	T 25	5 Nm
---	------	------

B 33.2.4.1.2

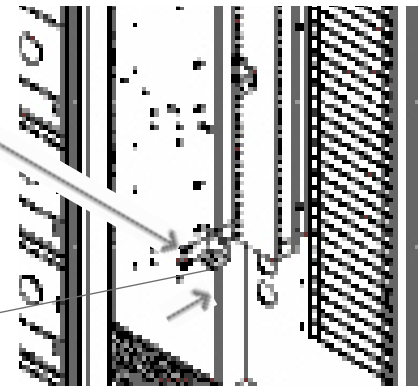

9674.410 – 9674.418

B 33.2.4.1.3

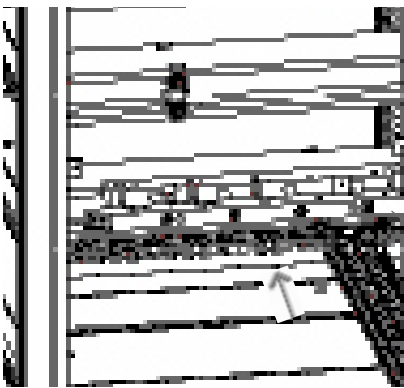

	SW 4	5 Nm
---	------	------

B 33.2.4.1.4

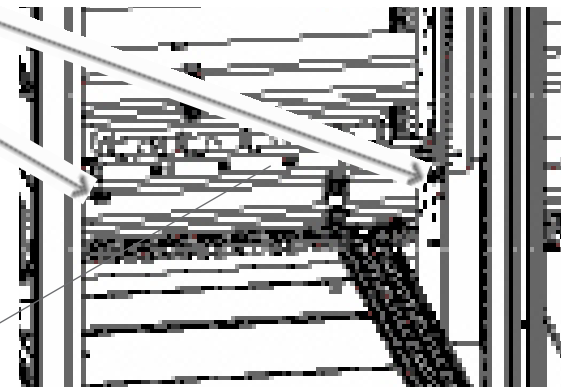

9674.410 – 9674.418

B 33.2.4.2.1 Jean Müller

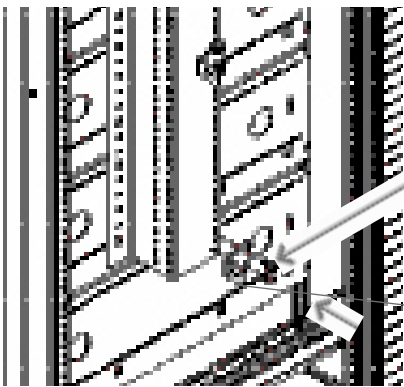

	T 25	5 Nm
---	------	------

B 33.2.4.2.2

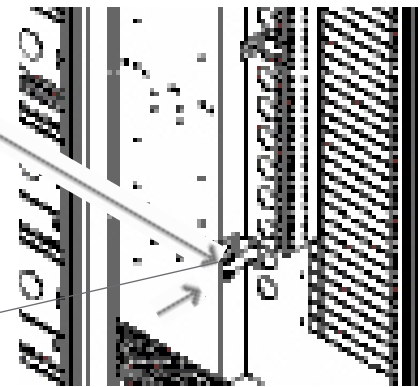

9674.410 – 9674.418

B 33.2.4.2.3

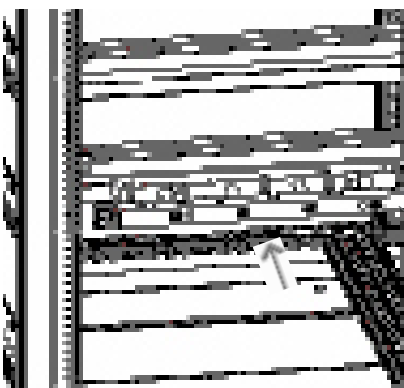

	SW 4	5 Nm
---	------	------

B 33.2.4.2.4

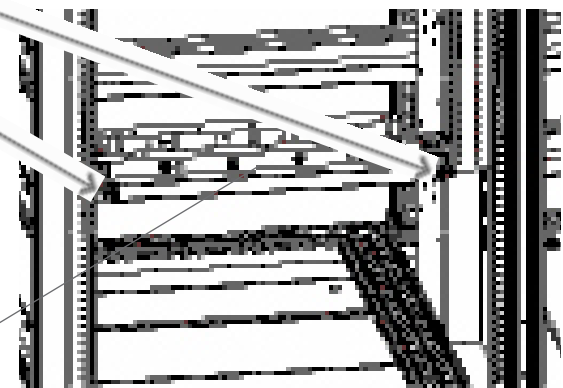

9674.410 – 9674.418

Установка распределительных шин в панели с планочными разъединителями со сборными шинами сзади снизу

B 33.2.5.1.1 ABB/Siemens

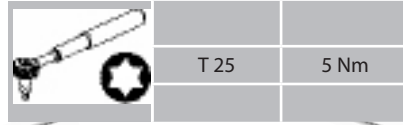
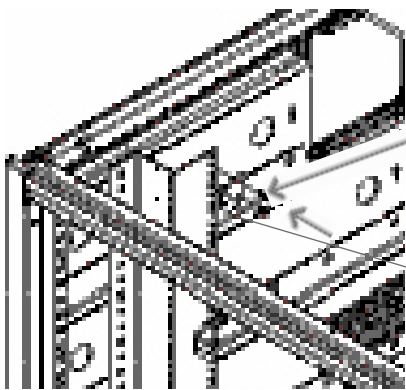

B 33.2.5.1.2

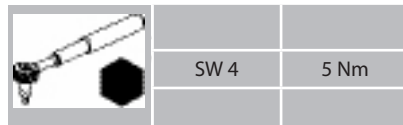
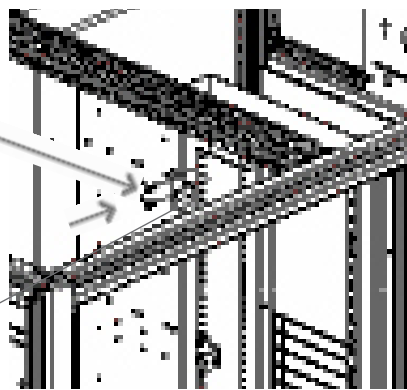

9674.410 – 9674.418

B 33.2.5.1.3

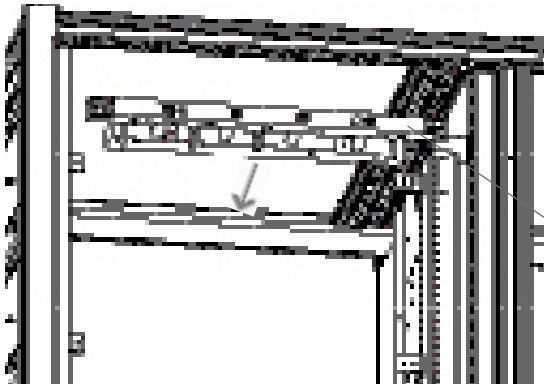

B 33.2.5.1.4

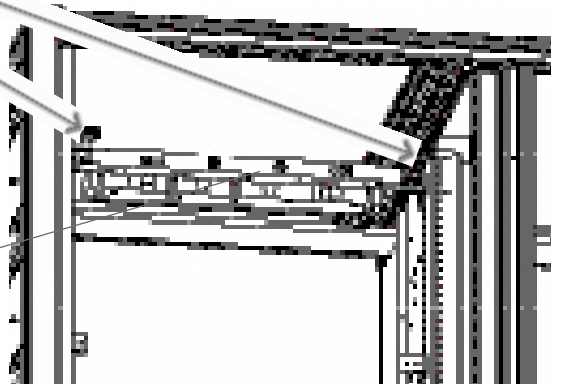

9674.410 – 9674.418

B 33.2.5.2.1 Jean Müller

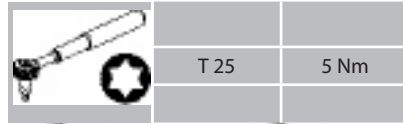
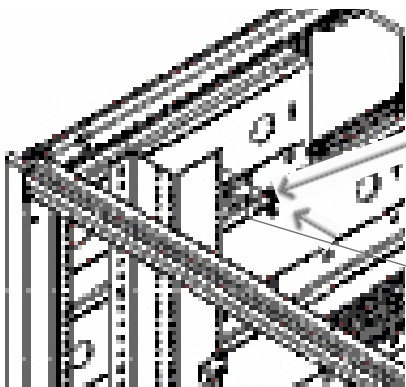

B 33.2.5.2.2

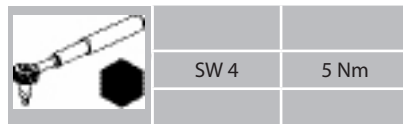
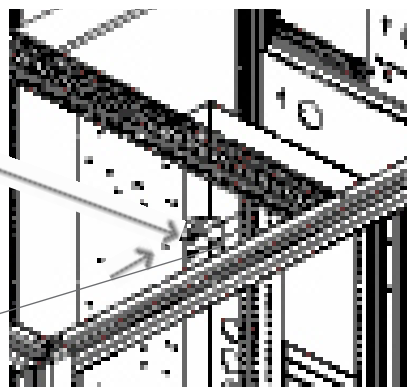

9674.410 – 9674.418

B 33.2.5.2.3

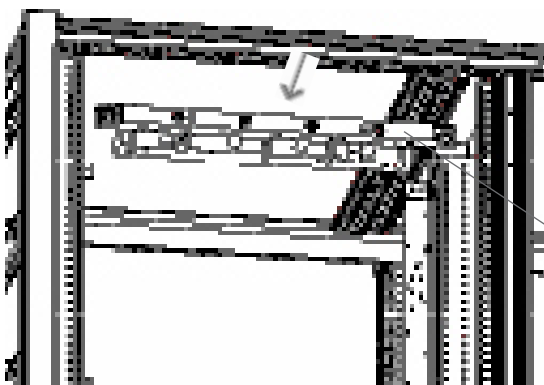

B 33.2.5.2.4

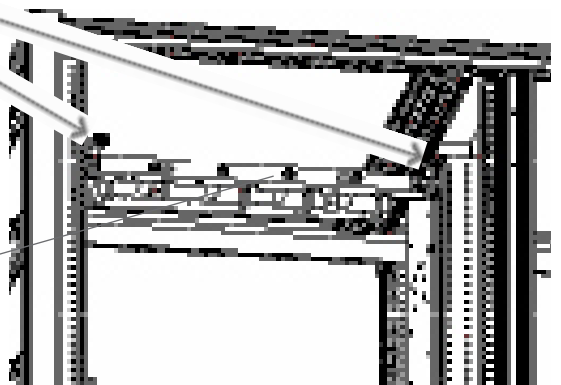

9674.410 – 9674.418

Установка распределительных шин в панели с планочными разъединителями со сборными шинами сзади снизу

Установка распределительных шин в панели с разъединителями Assembling the distribution busbar system

B 33.2.6

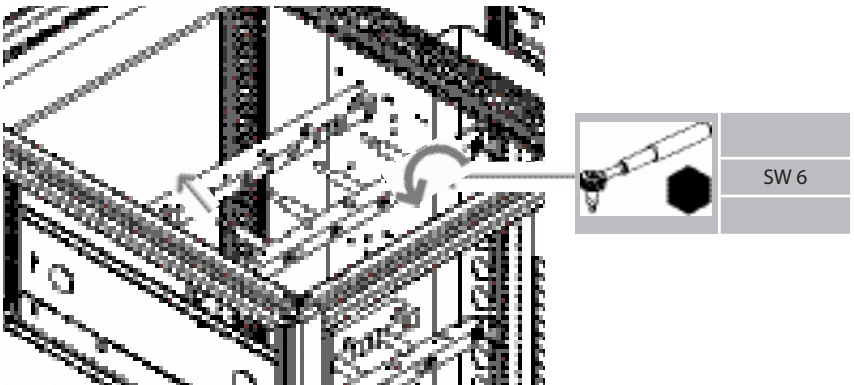

B 33.2.7.1 Jean Müller

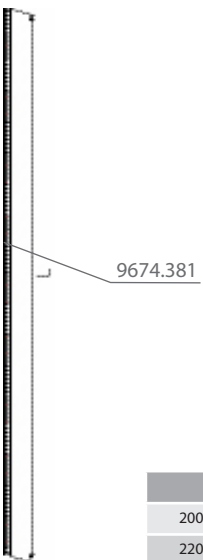

H	L
2000 mm	1537 mm
2200 mm	1737 mm



B 33.2.7.2

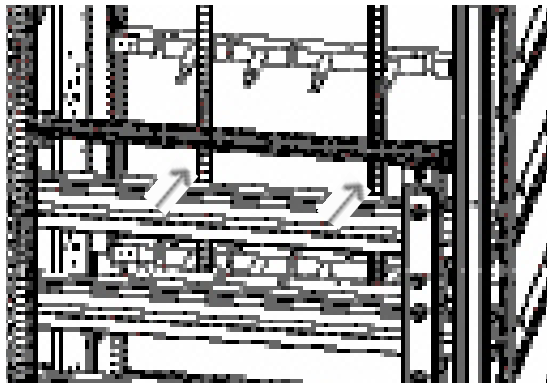

B 33.2.7.3

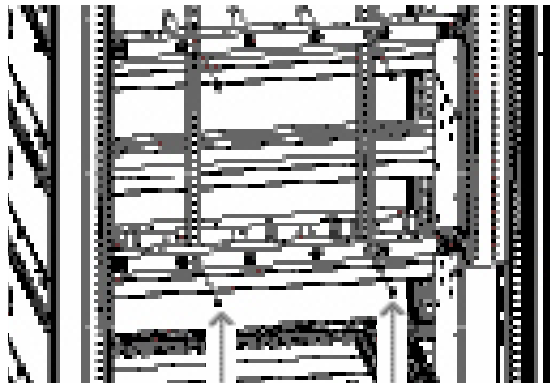

B 33.2.8.1

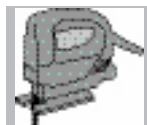
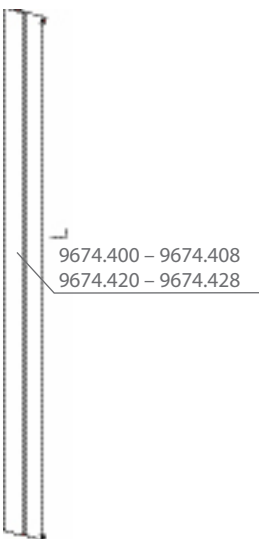

Сборные шины сзади снизу	H = 2000mm	H = 2200mm
	L	L
Maxi-PLS 1600/2000	1642,5 mm	1842,5 mm
Maxi-PLS 3200	1642,5 mm	1842,5 mm
Flat-PLS 60	1642,5 mm	1842,5 mm
Flat-PLS 100	1642,5 mm	1842,5 mm

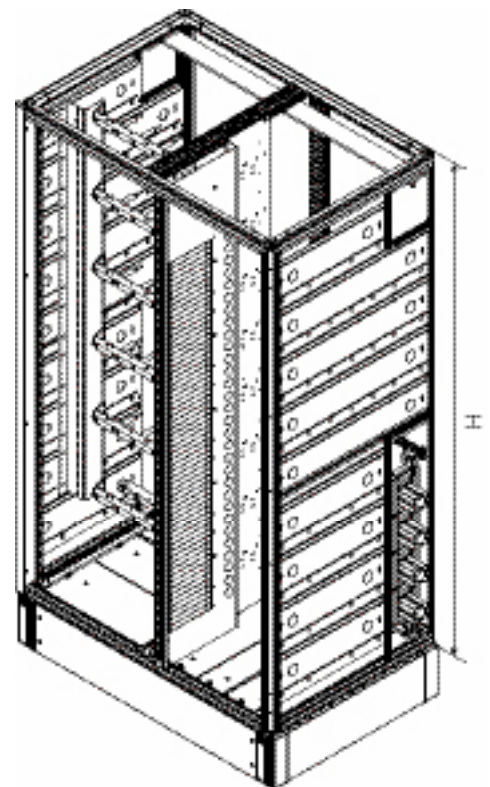

Установка распределительных шин в панели с планочными разъединителями со сборными шинами сзади снизу

B 33.2.8.2

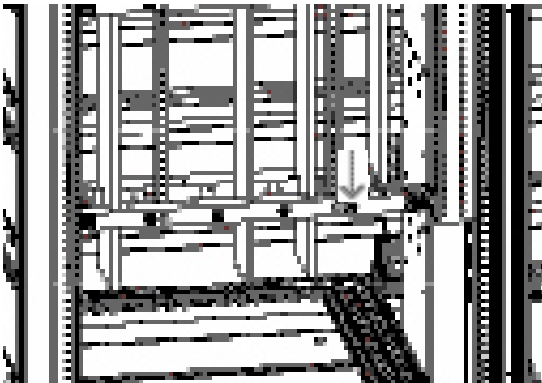

B 33.2.8.3

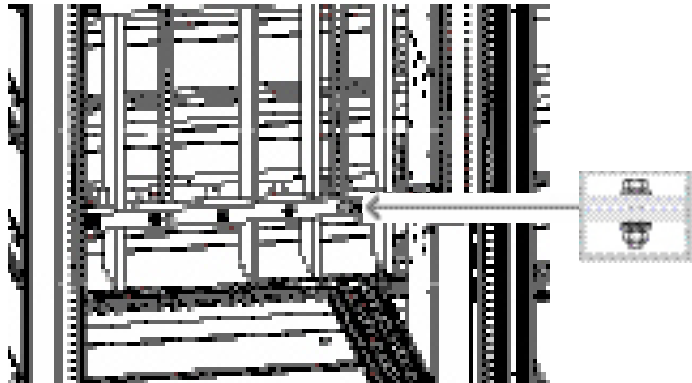

B 33.2.8.4

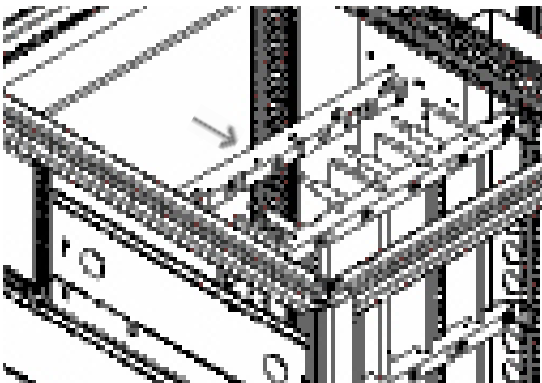

B 33.2.8.5

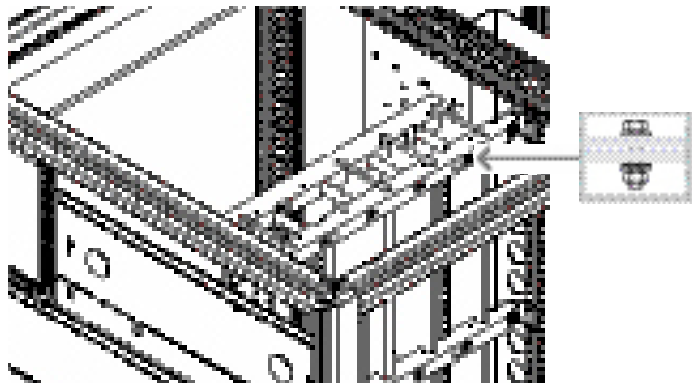

B 33.2.8.6

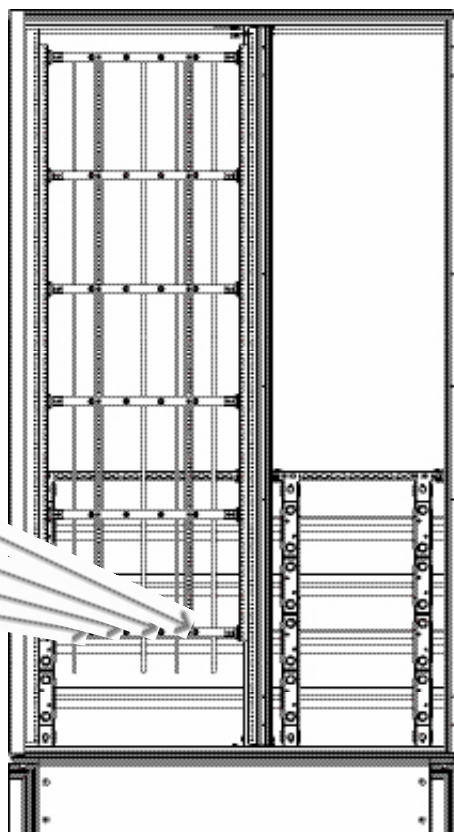

		SW 6	5 Nm
--	--	------	------

Установка соединения сборных шин сверху и вертикальных распределительных шин

Соединение сборных и распределительных шин в панели с разъединителями Assembling the busbar connection to the main busbar system

B 34.1.1.1.1

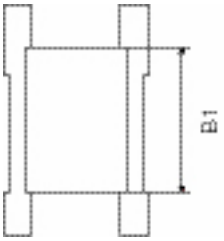

B 34.1.1.1.2

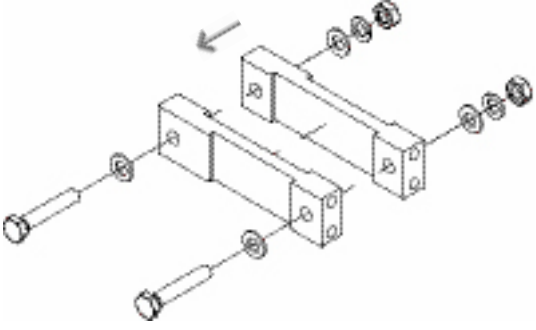

B 34.1.1.1.3

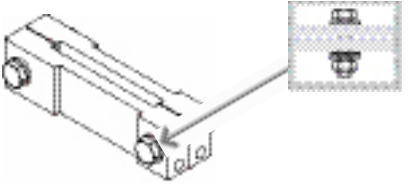

B 34.1.1.2.1

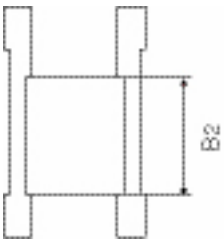

B 34.1.1.2.2

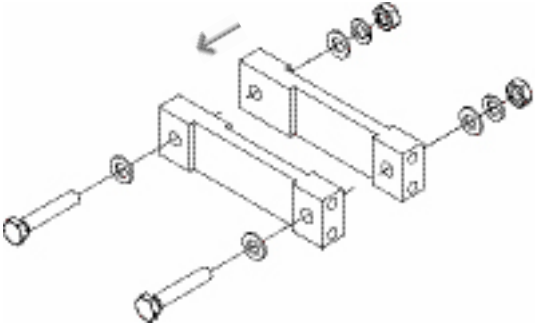

B 34.1.1.2.3

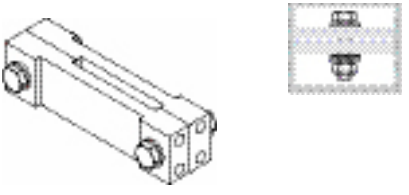

B1	B2	
-	50 mm	9674.485
60 mm	-	
-	80 mm	9674.488
100 mm	-	

B 34.1.1.3

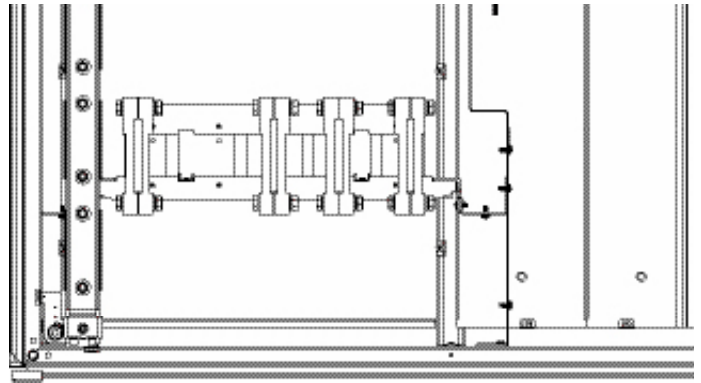

B 34.1.1.4

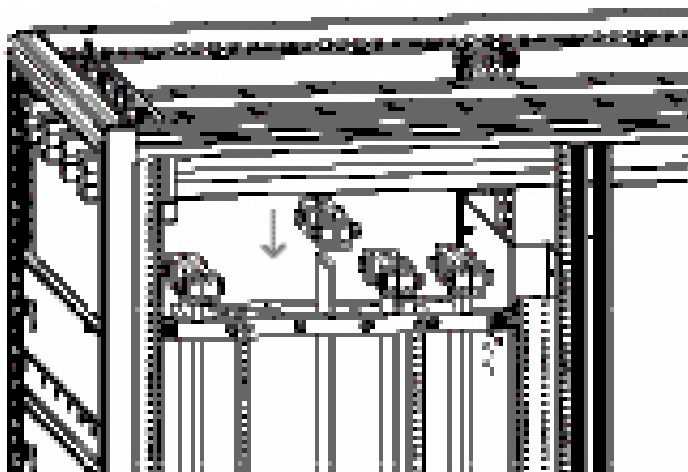

B 34.1.1.5

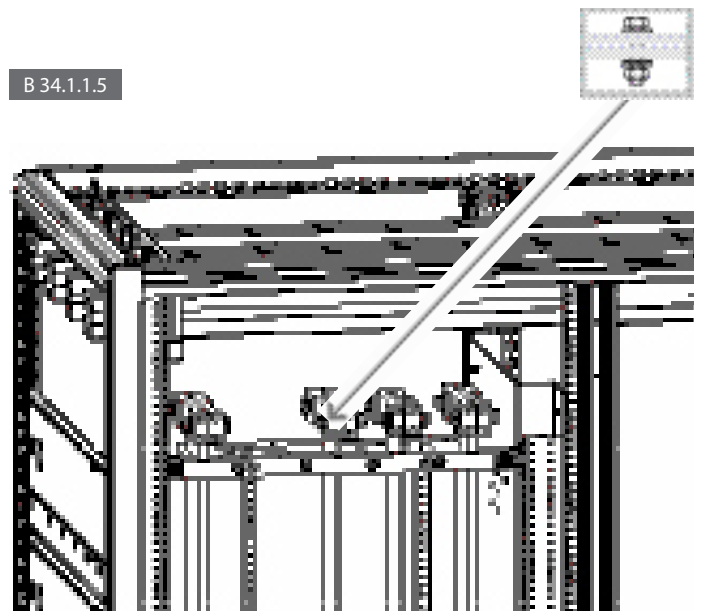

Установка соединения сборных шин Maxi-PLS сверху и вертикальных распределительных шин

В 34.1.2.1

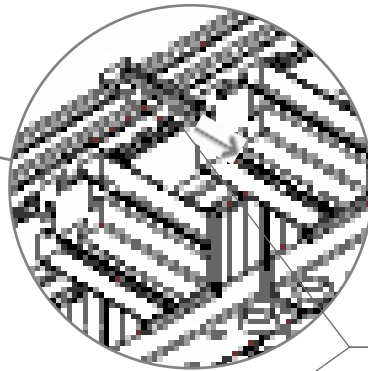
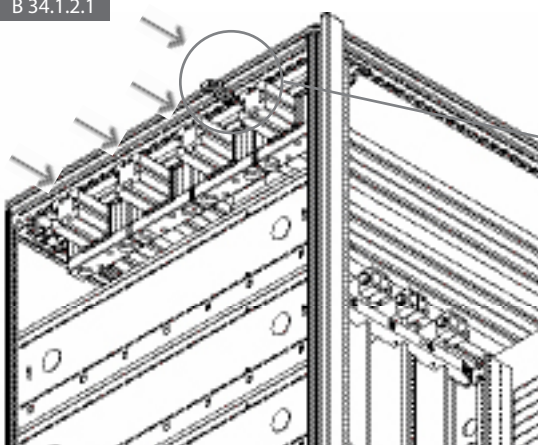

Maxi-PLS 1600	9640.171
Maxi-PLS 2000	9640.171
Maxi-PLS 3200	9650.171

В 34.1.2.2

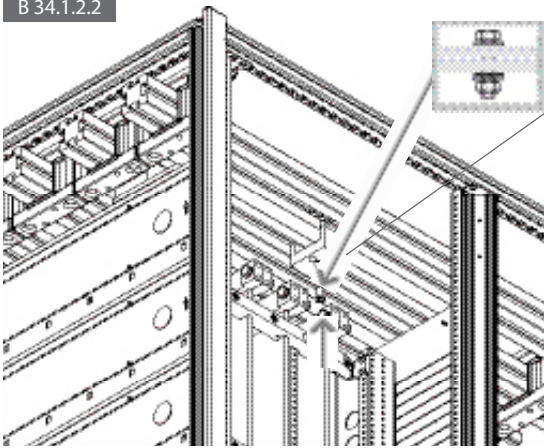

В 34.1.2.3

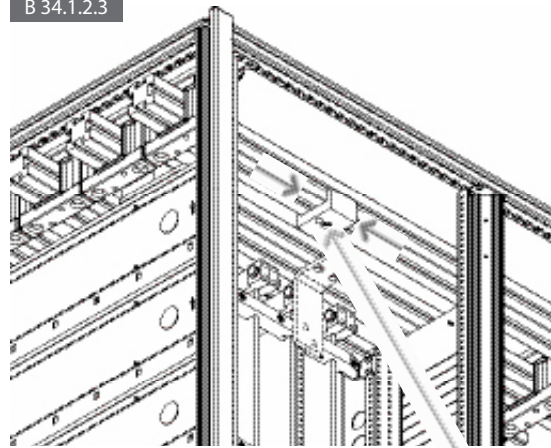

	1600	SW 7	15 Nm
	2000	SW 7	15 Nm
	3200	SW 8	20 Nm

В 34.1.2.4

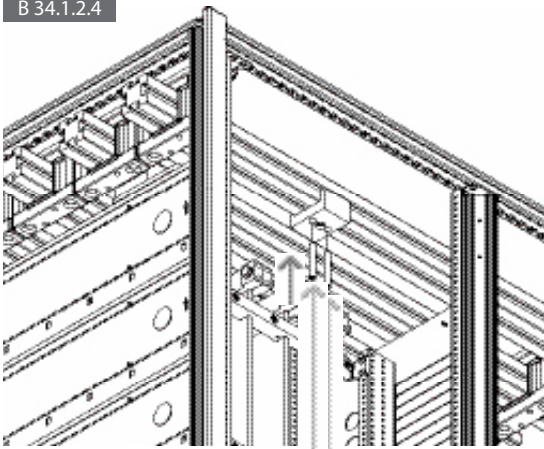

В 34.1.2.5

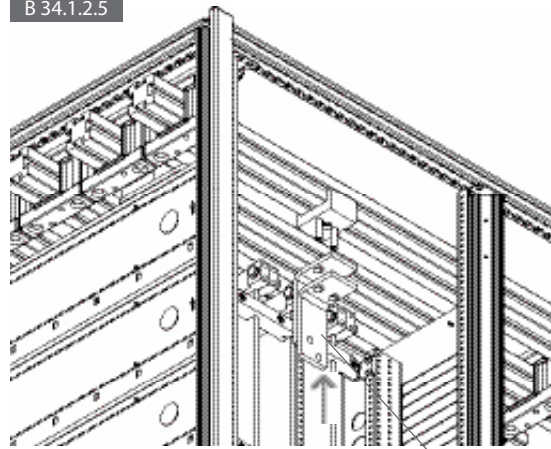

	1600	SW 5/6	10 Nm
	2000	SW 5/6	10 Nm
	3200	SW 5/6	10 Nm

9674.441 – 9674.448