

MELSEC A/Q

Programmable Logic Controllers

User's Manual

AJ95TB□-□□, AJ95FPB□-□□ Profibus Slave Modules

• SAFETY PRECAUTIONS •

(Read these precautions before using.)

When using Mitsubishi equipment, thoroughly read this manual and the associated manuals introduced in the manual. Also pay careful attention to safety and handle the module properly.

These precautions apply only to Mitsubishi equipment. Refer to the CPU module user's manual for a description of the PLC system safety precautions.

These • SAFETY PRECAUTIONS • classify the safety precautions into two categories: "DANGER" and "CAUTION".



DANGER

Procedures which may lead to a dangerous condition and cause death or serious injury if not carried out properly.



CAUTION

Procedures which may lead to a dangerous condition and cause superficial to medium injury, or physical damage only, if not carried out properly.

Depending on circumstances, procedures indicated by  CAUTION may also be linked to serious results. In any case, it is important to follow the directions for usage.

Store this manual in a safe place so that you can take it out and read it whenever necessary.

Always forward it to the end user.

[Design Precautions]



DANGER

- When communication over the data link is abnormal, the abnormal station may enter the state described below.

Use the communication status information to configure an interlock circuit on the sequence program so that the system operates safely.

Erroneous output or erroneous operation may cause an accident.

- (1) All outputs from the slave station are turned off.
- (2) All outputs from the slave station will be turned off after five to six seconds.
- (3) Depending on the slave I/O module trouble, I/O may remain continuously on or continuously off.

For I/O signals related to fatal trouble, provide an external monitoring circuit.



CAUTION

- Do not bundle control lines or communication wires together with main circuit or power lines, or lay them close to these lines.

As a guide, separate the lines by a distance of at least 100 mm (3.94 inch), otherwise malfunction may occur due to noise.

[Installation Precautions]

CAUTION

- Use the module in an environment that conforms to the general specifications in the CPU module user's manual.
Using the module in environments outside the ranges stated in the general specifications will cause electric shock, fire, malfunction, or damage to/deterioration of the product.
- Firmly fasten the module with the DIN rail, or mounting screws, and tighten the mounting screws within the specified torque range.
If the mounting screws are loose, the module may fall out or short circuit. If the mounting screws are too tight, the screw may break and cause the module fall out or short circuit.
- Perform correct pressure-displacement, crimp-contact or soldering for wire connections using the tools specified by the manufacturers. Attach connectors to the module securely.
Incomplete connection for the connectors may cause malfunction or short circuit.

[Wiring Precautions]

DANGER

- Completely turn off the external power when installing or placing wiring.
Not completely turning off all power could result in electric shock or damage to the product.

CAUTION

- Be sure to ground the FG terminal to the protected grounding conductor.
Otherwise there will be a danger of malfunction.
- Carry out wiring to the module correctly, checking the rated voltage and terminal arrangement of the product.
Using a power supply that does not conform to the rated voltage, or carrying out wiring incorrectly, will cause fire or failure.
- Tighten the terminal screws within the specified tighten torque range. Loose terminal screws may cause a short circuit or malfunction. If the screws are too tight, the screws may break and cause a short circuit or malfunction.
- Make sure that no foreign matter such as chips or wiring offcuts get inside the module.
It will cause fire, failure or malfunction.

[Startup and Maintenance Precautions]

DANGER

- Do not touch terminals or connectors while the power is ON.
This will cause electric shock or malfunction.
- Switch all phases of the external power supply off before cleaning or re-tightening terminal screws.
Not doing so could result in electric shock.
If the screws are loose, the module may fall out, short circuit, or malfunction.
If the screws are too tight, the module may fall out, short circuit, or malfunction.

CAUTION

- Do not disassemble or modify the module.
This will cause failure, malfunction, injuries, or fire.
- The module case is made of plastic. Do not drop it or subject it to strong shock. The module may break.
- Always turn off all the power phases at the outside before installing or removing the module to or from the panel. If all the phases are not turned off, the module may fail or operate erroneously.
- Set the connection switch of the terminal resistor before starting the operation.
Setting the switch while in operation may cause a network error, and such errors may not be detected.

[Disposal Precautions]

CAUTION

- Dispose of this product as industrial waste.

REVISIONS

* The manual number is given on the bottom left of the back cover.

Print Date	* Manual Number	Revision
Apr., 1997	SH (NA) 3628-A	First printing
Jan., 2002	SH (NA) 3628-B	AJ95FPBA4-16DE and AJ95FPBA2-16TE, AJ95FPBA42-16DTE are added.

This manual confers no industrial property rights or any rights of any other kind, nor does it confer any patent licenses. Mitsubishi Electric Corporation cannot be held responsible for any problems involving industrial property rights which may occur as a result of using the contents noted in this manual.

© 1997 MITSUBISHI ELECTRIC CORPORATION

INTRODUCTION

Thank you for choosing a Mitsubishi MELSEC-A Series General Purpose Programmable Controller. Before using your new PLC, please read this manual thoroughly to gain an understanding of its functions so you can use it properly. Please forward a copy of this manual to the end user.

CONTENTS

Safety Precautions	A- 1
Revisions	A- 4
Contents	A- 5
About Manuals	A- 7
1 OVERVIEW	1- 1 to 1- 3
1.1 Features	1- 1
1.2 How to Read the Slave I/O Module Model	1- 1
1.3 Cautions When Selecting a Slave I/O Module	1- 2
1.4 Introductory List of Connecting Devices	1- 3
2 NAME AND SETTING OF EACH AREA	2- 1 to 2- 5
3 GENERAL SPECIFICATIONS	3- 1 to 3- 2
4 INPUT MODULE SPECIFICATION	4- 1 to 4- 4
4.1 AJ95TB3-16D Input Module	4- 1
4.2 AJ95FPBA4-16DE 24VDC Input Module (Source type)	4- 3
5 OUTPUT MODULE SPECIFICATION	5- 1 to 5- 4
5.1 AJ95TB2-16T Output Module	5- 1
5.2 AJ65FBTA2-16TE Transistor Output Module (Source type)	5- 3
6 COMPOSITE MODULE SPECIFICATION	6- 1 to 6- 4
6.1 AJ95TB32-16DT Composite Module	6- 1
6.2 AJ95FPBA42-16DTE Composite Module	6- 4
7 HANDLING THE SLAVE I/O MODULE	7- 1 to 7- 5
7.1 Precautions When Handling or Installing the Slave I/O Module	7- 1
7.2 Connection Method	7- 3
7.3 Installing Slave I/O Module to DIN Rail (AJ95TB □ -16□)	7- 4
7.4 Handling of the Low Profile Waterproof Type Slave I/O Module	7- 5
7.4.1 List of model names of waterproof caps	7- 5
7.4.2 Waterproof cap installation method	7- 5
A - 5	A - 5

8 SLAVE I/O MODULE TROUBLE EXAMPLES	8- 1 to 8- 2
-------------------------------------	--------------

8.1 Examples and Countermeasures of Troubles in Input Circuit..... 8- 1

APPENDIX	App- 1 to App- 12
----------	-------------------

Appendix 1 External Dimensions Diagram.....App- 1

- Appendix 1.1 The AJ95TB3-16D module.....App- 1
- Appendix 1.2 The AJ95TB2-1T moduleApp- 2
- Appendix 1.3 The AJ95TB32-16DT moduleApp- 3
- Appendix 1.4 The AJ95FPBA4-16DE moduleApp- 4
- Appendix 1.5 The AJ95FPBA2-16TE module.....App- 5
- Appendix 1.6 The AJ95FPBA42-16DTE module.....App- 6

Appendix 2 DDB File.....App- 7

- Appendix 2.1 AJ95TB3-16DApp- 7
- Appendix 2.2 AJ95TB2-16TApp- 8
- Appendix 2.3 AJ95TB32-16DTApp- 9
- Appendix 2.4 AJ95FPBA4-16DEApp- 10
- Appendix 2.5 AJ95FPBA2-16TEApp- 11
- Appendix 2.6 AJ95FPBA42-16DTE.....App- 12

About Manuals

The following are manuals related to this product.

Request for the manuals as needed according to the chart below.

Related Manuals

Manual Name	Manual Number (Model Code)
PROFIBUS-DP interface module type A1SJ71PB92D User's Manual (Sold separately)	IB-66773 (13JL20)
PROFIBUS interface module type AJ71PB92 User's Manual (Sold separately)	IB-66569 (13J829)

1 OVERVIEW

1

This manual describes the specification of the slave station PROFIBUS-DP I/O module (referred to as slave I/O module hereafter), which can be connected to the PROFIBUS-DP (field system open network) network interface module (referred to as PRDFIBUS-DP master module hereafter).

1.1 Features

- (1) Conforms to DIN19245 (Part 1 and 3)
- (2) Maximum of 60 stations of slave I/O modules can be connected.
A maximum of 60 stations (32 stations per segment) of slave I/O modules can be connected by connecting a repeater.
- (3) The press-down-tightening-type connector enables installation/removal of terminal block to/from the module.
Wiring works can be eased by removing the terminal block from the module.
- (4) Equipped with a function to monitor load power supply of the output module.
- (5) Equipped with a built-in terminal resistor, which can be switched with a DIP switch.
Because the terminal resistor is pre-installed, there is no need of wiring.
- (6) External connection of the PROFIBUS I/F is performed with a 9-pin D-SUB connector.
(Conforms to DIN19245 Part 1 and 3.)
- (7) CE marking/EMC compatible (conforms to IEC 1131-2)

1.2 How to Read the Slave I/O Module Model

The following describes how to read the slave I/O module model:

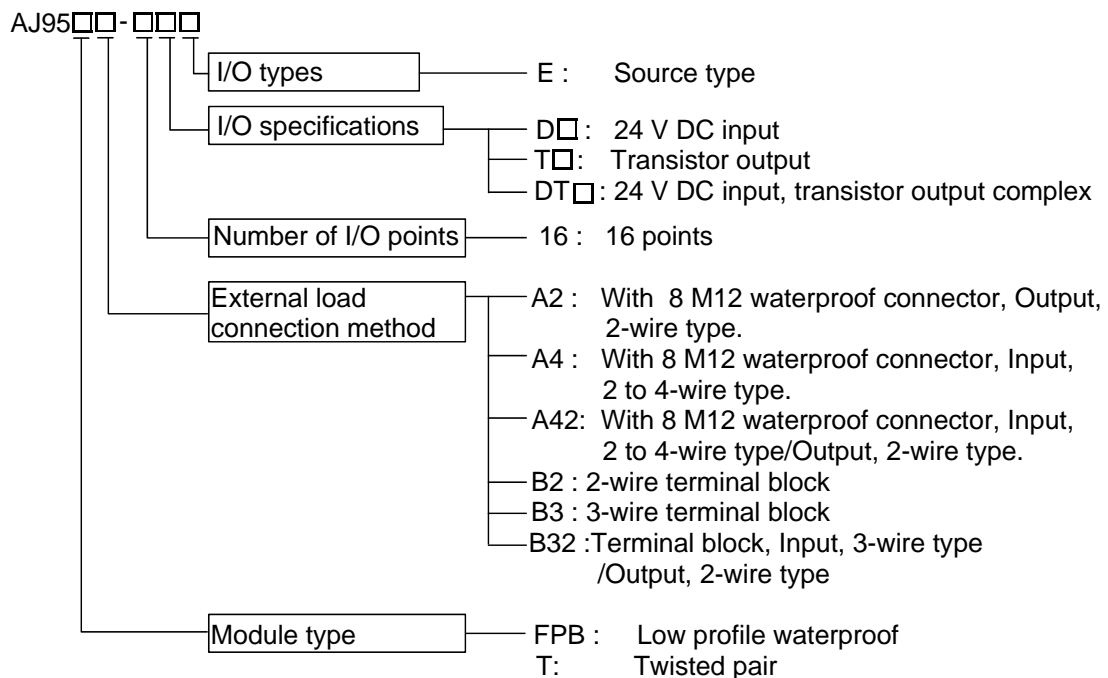

1.3 Cautions When Selecting a Slave I/O Module

Cautions when selecting a slave I/O module to be used with the PROFIBUS-DP master are described below.

- (1) This is a slave I/O module dedicated for the PROFIBUS-DP network. Do not connect this module to a different data link system, such as the MELSECNET/MIN data link system.
- (2) When connecting a sensor directly to the slave I/O module, it is recommended to use a 2-wire-type module with more common lines, which does not require a relay terminal block and thus makes the wiring work easier.
- (3) When using a counter or timer which uses a DC/DC converter as a load to the transistor output module with a maximum load current of 0.8A, breakdowns may occur if the module is selected based on the average current, because rush current flows with constant intervals during ON or while in operation. Therefore, if the above load is used, connect a resistor or inductance in series with the load in order to reduce the effect of rush current, or use an output module with greater maximum load current capacity.

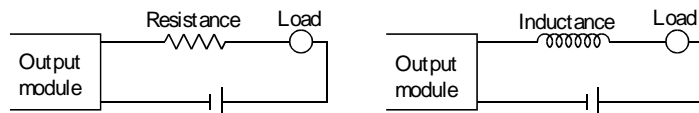

1.4 Introductory List of Connecting Devices

An introductory list of connecting devices needed for use of the low profile waterproof type SLAVE I/O module (AJ95FBA□-16□) is shown below.

(1) Communications Module Waterproof Plug (Male / Female) . . . 5-pin only can be used.

(a) For LINK In Side (Female)

Model Name	Maker	Specifications	Connection Cable Diameter
ELKA 5012 PG9	HIRSCHMANN	M12-5-pin Female Straight Type	φ 6.0 to 8.0mm
CM02A-8DP5S(03)	DDK Ltd.		φ 8.0mm
ELWIKA 5012 PG9	HIRSCHMANN	M12-5-pin Female Right-angle Type	φ 6.0 to 8.0mm

(b) For LINK OUT Side (Male)

Model Name	Maker	Specifications	Connection Cable Diameter
ELST 4012 PG9	HIRSCHMANN	M12-4-pin Male Straight Type	φ 6.0 to 8.0mm
ELST 5012 PG9	HIRSCHMANN	M12-5-pin Male Straight Type	φ 6.0 to 8.0mm
CM02A-8DJ5P(03)	DDK Ltd.		φ 8.0mm
ELWIST 4012 PG9	HIRSCHMANN	M12-4-pin Male Right-angle Type	φ 6.0 to 8.0mm
ELWIST 5012 PG9	HIRSCHMANN	M12-5-pin Male Right-angle Type	φ 6.0 to 8.0mm

(2) Power Supply Module - Waterproof Plug (Female) . . . 5-pin only can be used.

Model Name	Maker	Specifications	Connection Cable Diameter
ELKA 5012 PG7	HIRSCHMANN	M12-5-pin Female Straight Type	φ 4.0 to 6.0mm
ELKA 5012 PG9			φ 6.0 to 8.0mm
CM02A-8DP5S(03)	DDK Ltd.		φ 8.0mm
ELWIKA 5012 PG7	HIRSCHMANN	M12-5-pin Female Right-angle Type	φ 4.0 to 6.0mm
ELWIKA 5012 PG9			φ 6.0 to 8.0mm

2 NAME AND SETTING OF EACH AREA

The name and setting of each area of the slave I/O module are described.

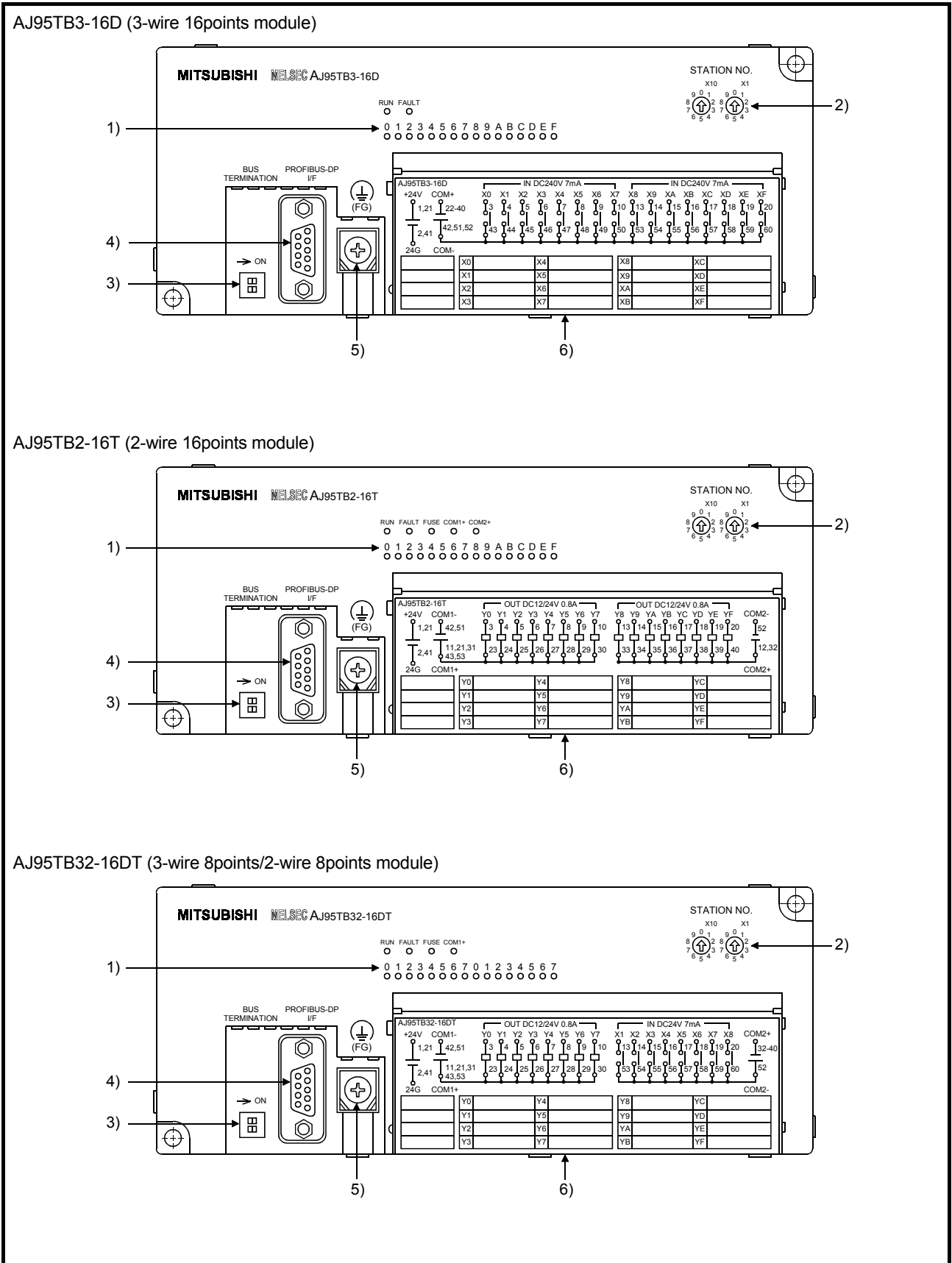

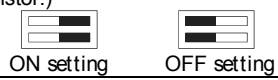
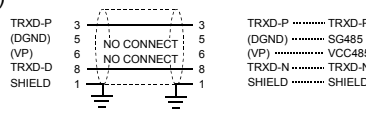
No.	Name	Contents				
1)	Operation indication	LED name	Check contents			
		RUN	Lights when normal power is being supplied to the module.			
		FAULT	Lights when DP I/O cannot communicate normally. (Watchdog timer error after reset, etc.) Lights when the station address does not match the set address.			
		FUSE	Lights when the load voltage of an output module is interrupted. (When a fuse blows or the external power supply is turned off)			
		COM1+	Lights when normal output module load power supply COM1+ voltage is supplied. Goes off when the voltage supply is interrupted or is disconnected.			
		COM2+	Lights when normal output module load power supply COM2+ voltage is supplied. Goes off when the voltage supply is interrupted or is disconnected.			
		0 to F	Indicates the output ON/OFF state. Lights when output is ON.			
2)	Station number setting switch	Sets the module station number from 3 to 99. (Duplicate station numbers cannot be set.) ×10 sets the station number tens digit and ×1 sets the station number modules digit. After changing the station number, 24DC voltage module power supply need to be turned off once, and then turn it on again.				
3)	Terminating resistor connect/disconnect selector switch	Selects whether to connector or disconnect the terminating resistor inside the module. Right (ON): Connect Left (OFF): Disconnect When mounting and dismantling the module offline, set this switch to OFF and use a D-SUB with built-in terminating resistor. (Do not mount or dismount the module while online except when using a signal connector with built-in terminating resistor.) 				
4)	DP I/F PROFIBUS transmission	Complies with RS485 Connection uses a 9-pin D-SUB connector plug type connector (mating threads — inch threads): Provided by the user.				
		1) Pin assignment From DIN19245 PART1				
		Pin No.	Option	Signal name	Application	Installation to product
		1	Standard	SHIELD	Shield Protective Ground	○
		2	Option	RP	Received for power (+24V)	×
		3	Standard	TRXD-P	Receive/Transmit-Data-P	○
		4	Option	CNTR-P	Control-P	×
		5	Option	DGNO	Data Ground	○
		6	Option	VP	Voltage-Plus	○
		7	Option	RP	Received for power (-24V)	×
8	Standard	TRXD-N	Received/Transmit-Data-N	○		
9	Option	CNTR-N	Control-P	×		
2) Wiring specifications (Option)						
3) Transmission line						
Item	Contents		Remarks			
Terminating resistor	$1/4W\ 390\Omega \pm 2\% \times 2$ $1/4W\ 220\Omega \pm 2\% \times 1$		Built-in Connect/disconnect selected by built-in switch			
Cable specifications	Applicable cable	Twisted pair cable		Provided by user: Use shielded cable.		
	Impedance Z	130-165Ω (3-20MHz)				
	Capacitance	<30nF/km				
	Conductor resistance	<110Ω/km				
	Conductor cross sectional area	>0.34mm ²				
5)	FG terminal	Terminal that connects ground to the control panel, etc. (Must be grounded when EMC compatibility is necessary.) M4 Phillips-head and flat-head screw (Crimp terminal can be used)				

No.	Name	Contents
6)	I/O terminal block (including module power supply)	Two-piece insertion type terminal board for I/O signal line and module power line connection. Can be detached from the module Two M3.5 Phillips-head and flat-head screws (Specified torque range 55 to 75N•cm) *1

*1 Only a single wire, or one twisted wire, can be used as the electric wire . The terminal cannot hold multiple wires.

Electric wire processing



To ensure that the terminals are isolated, the end of the electric wire must be processed and inserted into the terminals. The end of twisted wire, in particular, must not be unraveled.

Covering stripping length: 6 to 8mm

AJ95FPBA□-16□ (Low profile waterproof connector 16 points module)

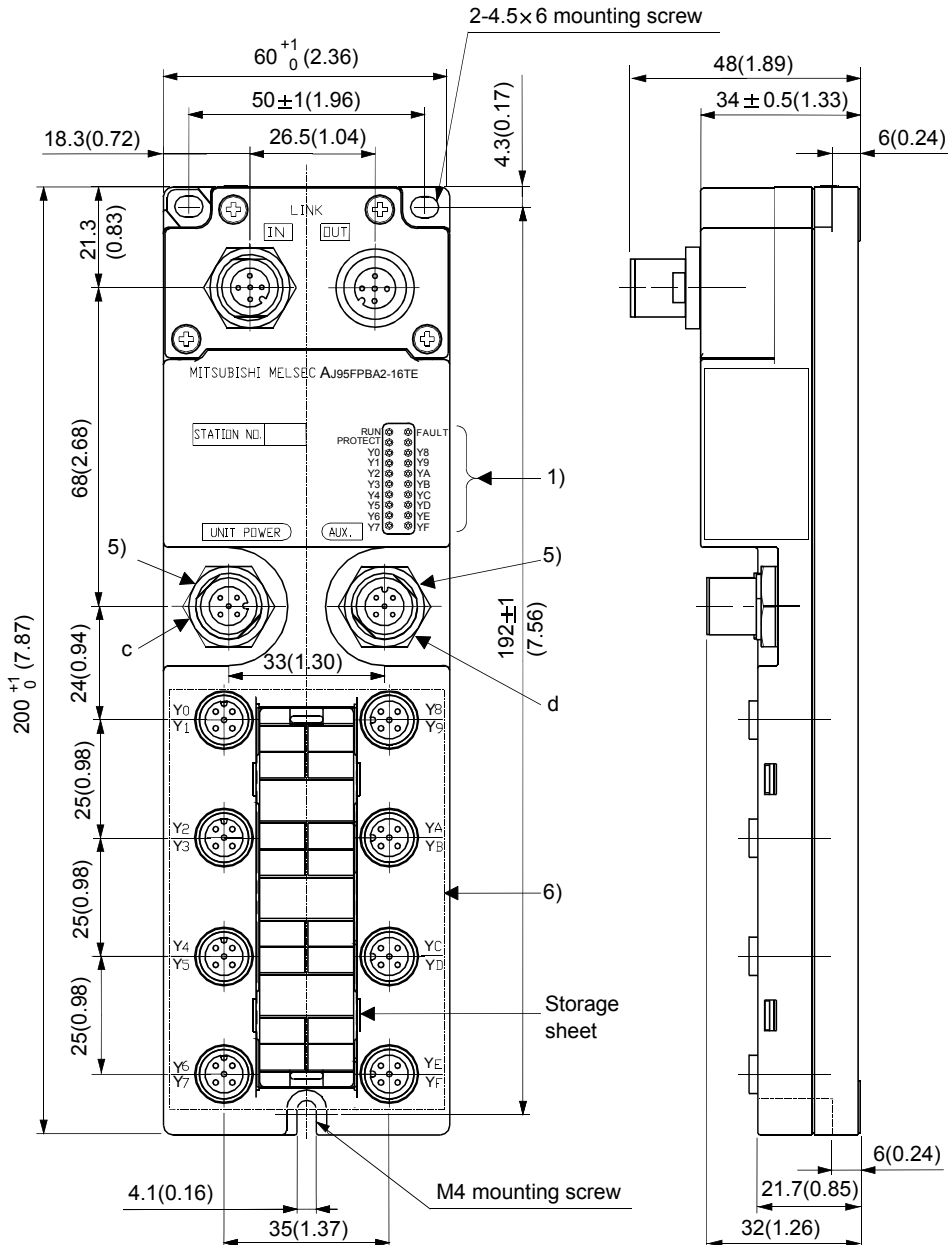
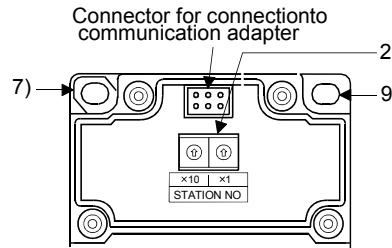
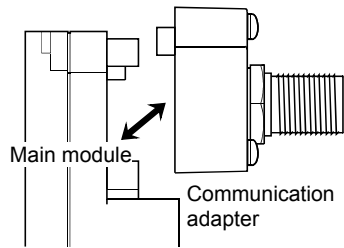
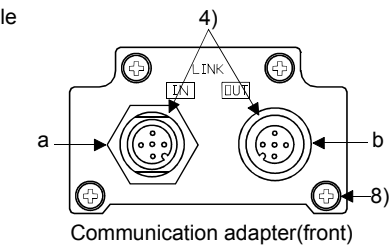
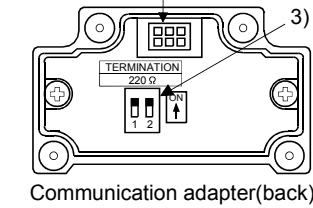
Connector for connection to main module



No.	Item	Description										
1)	Operating status indicator LEDs	LED name	Confirmation details									
		POWER	Lights when normal power is being supplied to the module.									
		PROTECT	Lights up when the output section protection function is working. (During the protect operation, fuse interruption is searched in the master unit side.)									
		FAULT	Lights when DP I/O cannot communicate normally. (Watchdog timer error after reset, etc.) Lights when the station address does not match the set address.									
		Y0 to YF	On: OUTPUT ON. Off: OUTPUT OFF.									
2)	Station number setting switches	Sets the module station number from 3 to 99. (Duplication station numbers cannot be set.) x10 sets the station number tens digit and x1 sets the station numbers digit. Remove the communication adapter on the top part of the module to set the station number. (When shipped from the factory, all settings are set to OFF.)										
3)	Terminal resistance setting switches	Selects whether to connect the terminating resistor inside the module. Up(ON):Connect Down(OFF):Disconnect   ON setting OFF setting (When shipped from the factory, all settings are set to OFF.)										
4)	Waterproof connector for transmission line *1	<table border="1"> <thead> <tr> <th></th> <th>Silk</th> <th>Contents</th> </tr> </thead> <tbody> <tr> <td>a</td> <td>LINK IN</td> <td>Connector for connecting the transmission line from the IN side (master station side). (Male 5 pins)</td> </tr> <tr> <td>b</td> <td>LINK OUT</td> <td>Connector for connecting the transmission line from the OUT side. Be sure to attach the waterproof cap when not in use. (Female 5 pins)</td> </tr> </tbody> </table>			Silk	Contents	a	LINK IN	Connector for connecting the transmission line from the IN side (master station side). (Male 5 pins)	b	LINK OUT	Connector for connecting the transmission line from the OUT side. Be sure to attach the waterproof cap when not in use. (Female 5 pins)
	Silk	Contents										
a	LINK IN	Connector for connecting the transmission line from the IN side (master station side). (Male 5 pins)										
b	LINK OUT	Connector for connecting the transmission line from the OUT side. Be sure to attach the waterproof cap when not in use. (Female 5 pins)										
5)	Waterproof connector for transmission line *1	<table border="1"> <thead> <tr> <th></th> <th>Silk</th> <th>Contents</th> </tr> </thead> <tbody> <tr> <td>c</td> <td>UNIT POWER</td> <td>Connector for supplying power to the module. (Male 5 pins)</td> </tr> <tr> <td>d</td> <td>AUX.</td> <td>Connector for supplying power to a load, etc. (Male 5 pins)</td> </tr> </tbody> </table>			Silk	Contents	c	UNIT POWER	Connector for supplying power to the module. (Male 5 pins)	d	AUX.	Connector for supplying power to a load, etc. (Male 5 pins)
	Silk	Contents										
c	UNIT POWER	Connector for supplying power to the module. (Male 5 pins)										
d	AUX.	Connector for supplying power to a load, etc. (Male 5 pins)										
6)	Waterproof connector for input/output connection *1	Waterproof connector for connection input/output signal. (Female 5 pins) Be sure to attach waterproof cap A6CAP-WP2 (sold separately) when not in use. (Tightening torque range: 0.29·N·m to 0.34 N·m.)										
7)	FG metal fitting	For module FG terminal (tightening torque range: 0.78 N·m to 1.18 N·m)										
8)	Screw for communication adapter removal/attachment	Use this screw for removal/attachment of the communication adapter to the main module when online or when changing the switch settings. (Tightening torque range: 0.42 N·m to 0.58 N·m.)										
9)	Module attachment hole	Screw hole for module attachment. 2-4.5 X 6 length hole (M4 attachment screw) (Tightening torque range: 0.78 N·m to 1.18 N·m).										

*1: Waterproof connector (based on IEC947-5-2, M12 type)

3 GENERAL SPECIFICATIONS

This common specifications for the different modules used are as follows.

Table 3.1 General specifications

Item	Specifications					
Operating ambient temperature	0 to 55 °C					
Storage ambient temperature	-20 to 75 °C					
Operating ambient humidity	10 to 90 % RH, No condensation (The waterproof remote I/O module conforms to IP67. * ⁴)					
Storage ambient humidity	10 to 90 % RH, No condensation					
Vibration resistance	Conforming to IEC 61132-2		Frequency	Acceleration	Amplitude	Sweep Count 10 times each in X, Y and Z axis (80 minutes)
		When there is intermittent vibration	10 to 57 Hz	—	0.075 mm	
		When there is continuous vibration	57 to 150 Hz	9.8 m/S ² {1G}	—	
			10 to 57 Hz	—	0.035 mm	
Shock resistance	Conforming to IEC 61131-2 (147 m/s ² {15G}, 3 times each in 3 directions)					
Operating environment	No corrosive gas present					
Operating height	2000 m(6562 ft) or less * ³					
Installation area	On the control board					
Over-voltage category * ¹	II or less					
Pollution rate * ²	2 or less					

- *1 Indicates the location where the device is connected from the public cable network to the device structure wiring area.
Category II applies to the devices to which the power is supplied from a fixed equipment. Surge withstand voltage for devices with up to 300 V of rated voltage is 2500 V.
- *2 This is an index which indicates the degree of conductive object generation in the environment Pollution level 2 is when only non-conductive pollution occurs.
A temporary conductivity caused by condensation must be expected occasionally.
- *3 Do not use or store the PLC in the environment where the pressure is higher than the atmospheric pressure at sea level. Otherwise, malfunction may result. To use the PLC in high-pressure environment, contact your nearest Mitsubishi representative.
- *4 Applicable only when all waterproof connectors are being used, or when waterproof caps are installed on unused waterproof connectors.

4 INPUT MODULE SPECIFICATION

Specification of the input module that can be connected to the PROFIBUS-DP network is described.

4.1 AJ95TB3-16D Input Module

Specification		AJ95TB3-16D Input Module
Transmission speed (kbps)		9.6/19.2/93.75/187.5/500/1500/3000/6000/12000
Number of input points		16 points
Insulation method		Photocoupler insulation
Rated input voltage		24VDC
Rated input current		Approx. 7mA
Operating voltage range		19.2 to 26.4 VDC (ripple: less than 5%)
Max. simultaneous input points		100% (16 points) simultaneously ON
ON voltage/ON current		14V or higher/3.5mA or higher
OFF voltage/OFF current		6V or lower/1.7mA or less
Input impedance		Approx. 3.3k Ω
Response time	OFF→ON	10msec or less
	ON→OFF	10msec or less
Common method		16 points/common (+COM 16 terminal/—COM 16 terminal)
Input method		Sink/Source common type
Number of occupied station		1 station
I/O module power supply	Voltage	15.6VDC to 31.2VDC (peak voltage)
	Current	174mA (24.0VDC)
Noise durability		First transient burst noise (IEC801-4) 2kV DC type noise voltage 500Vp-p Noise width 1 μ s, Noise frequency 25 to 60Hz (noise simulator condition) fast transient burst noise IEC 801-4 2kv
Withstanding voltage		500VAC for 1 minute between all DC external terminals together and ground.
Insulation resistance		10M Ω or higher, measured with a 500VAC insulation resistance tester.
Weight kg (lb)		0.45 (0.99)
External connection method	I/O, power supply	Insertion type terminal board (M2.5 flat head machine screw) Specified torque range 0.25 to 0.35 N·m
	FG	M4 Phillips-head and flat-head screw terminal Specified torque range 1.00 to 1.35N·m Applicable crimp terminal RAV1.25-4, RAV2-4
	Transmission circuit	9-pin D-SUB connector (receptacle)
Applicable electric wire size		0.18 to 2mm ² (single wire or twisted wire)
Module mounting screws		M4 × 0.7 × 16mm or larger screws (Specified torque range 0.78 to 1.18N·m) Mounting by DIN rail also possible.
Applicable DIN rail		TH35-7.5Fe, TH35-7.5Al, TH35-15Fe (Conforms to JIS-C2812 or DIN, EN, IEC standard 35mm wide top hat rail)

External connection

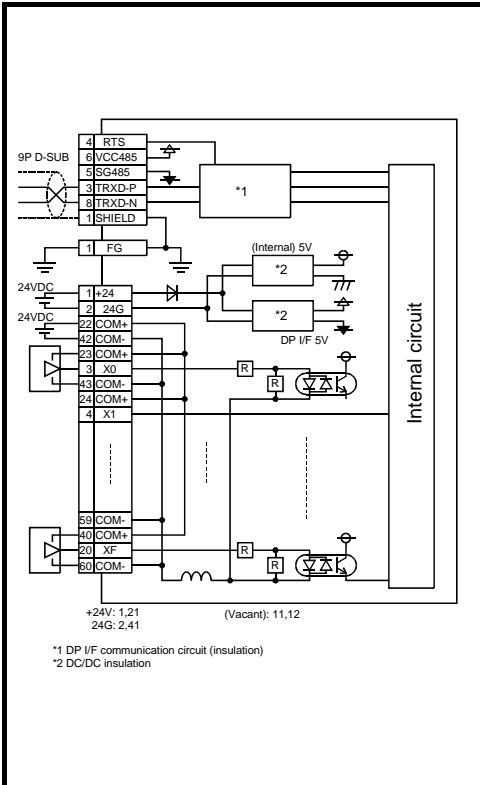

Terminal No.	Signal name	Terminal No.	Signal name	Terminal No.	Signal name
TB1	+24V	TB21	+24V	TB41	24G
TB2	24G	TB22	COM+	TB42	COM-
TB3	X0	TB23	COM+	TB43	COM-
TB4	X1	TB24	COM+	TB44	COM-
TB5	X2	TB25	COM+	TB45	COM-
TB6	X3	TB26	COM+	TB46	COM-
TB7	X4	TB27	COM+	TB47	COM-
TB8	X5	TB28	COM+	TB48	COM-
TB9	X6	TB29	COM+	TB49	COM-
TB10	X7	TB30	COM+	TB50	COM-
TB11	NC	TB31	COM+	TB51	COM-
TB12	NC	TB32	COM+	TB52	COM-
TB13	X8	TB33	COM+	TB53	COM-
TB14	X9	TB34	COM+	TB54	COM-
TB15	XA	TB35	COM+	TB55	COM-
TB16	XB	TB36	COM+	TB56	COM-
TB17	XC	TB37	COM+	TB57	COM-
TB18	XD	TB38	COM+	TB58	COM-
TB19	XE	TB39	COM+	TB59	COM-
TB20	XF	TB40	COM+	TB60	COM-

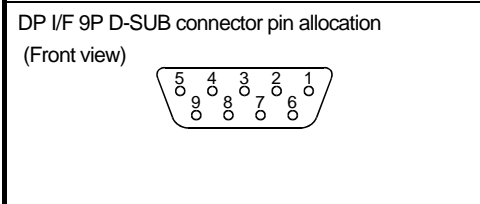

No.	Signal name	No.	Signal name
1	SHIELD	6	VCC485
2	NC	7	NC
3	TRXD-P	8	TRXD-N
4	RTS	9	NC
5	SG485		

4

4.2 AJ95FPBA4-16DE 24VDC Input Module (Source type)

Specification	DC input module
Transmission speed	9.6/ 19.2/ 93.75/ 187.5/ 500/ 1500/ 3000/ 6000/ 12000
Number of output points	16 points
Isolation method	Photocoupler
Rated input voltage	24VDC
Rated input current	Approx. 7mA
Operating voltage range	20.4 to 26.4VDC (ripple ratio : within 5%)
Max. simultaneous ON input points	100 %
ON voltage/ON current	14V or higher/3.5mA or higher
OFF voltage/OFF current	6V or lower/1.7mA or lower
Input resistance	Approx. 3.3k Ω
Response time	OFF \rightarrow ON 1.5ms or lower (when 24VDC)
	ON \rightarrow OFF 1.5ms or lower (when 24VDC)
Common wiring method	16 points/1 common (waterproof connector 2 to 4-wire type)
Input form	Negative Common (Source type)
Number of stations occupied	1 station
I/O module power supply	Voltage 20.4 to 26.4VDC (ripple ratio : within 5%)
	Current 65mA or lower (When 24VDC and all point is on)
Noise durability	DC type noise withstand voltage 500Vp-p noise width 1 μ s, noise carrier frequency 25 to 60Hz (noise simulator condition)
Withstand voltage	500VAC for 1 minute between all DC external terminals and ground
Insulation resistance	10M Ω or higher, measured with a 500VDC insulation resistance tester
Protection of degree	IP67
Weight	0.40kg
Option	Waterproof cap : A6CAP-WP2

External Connections

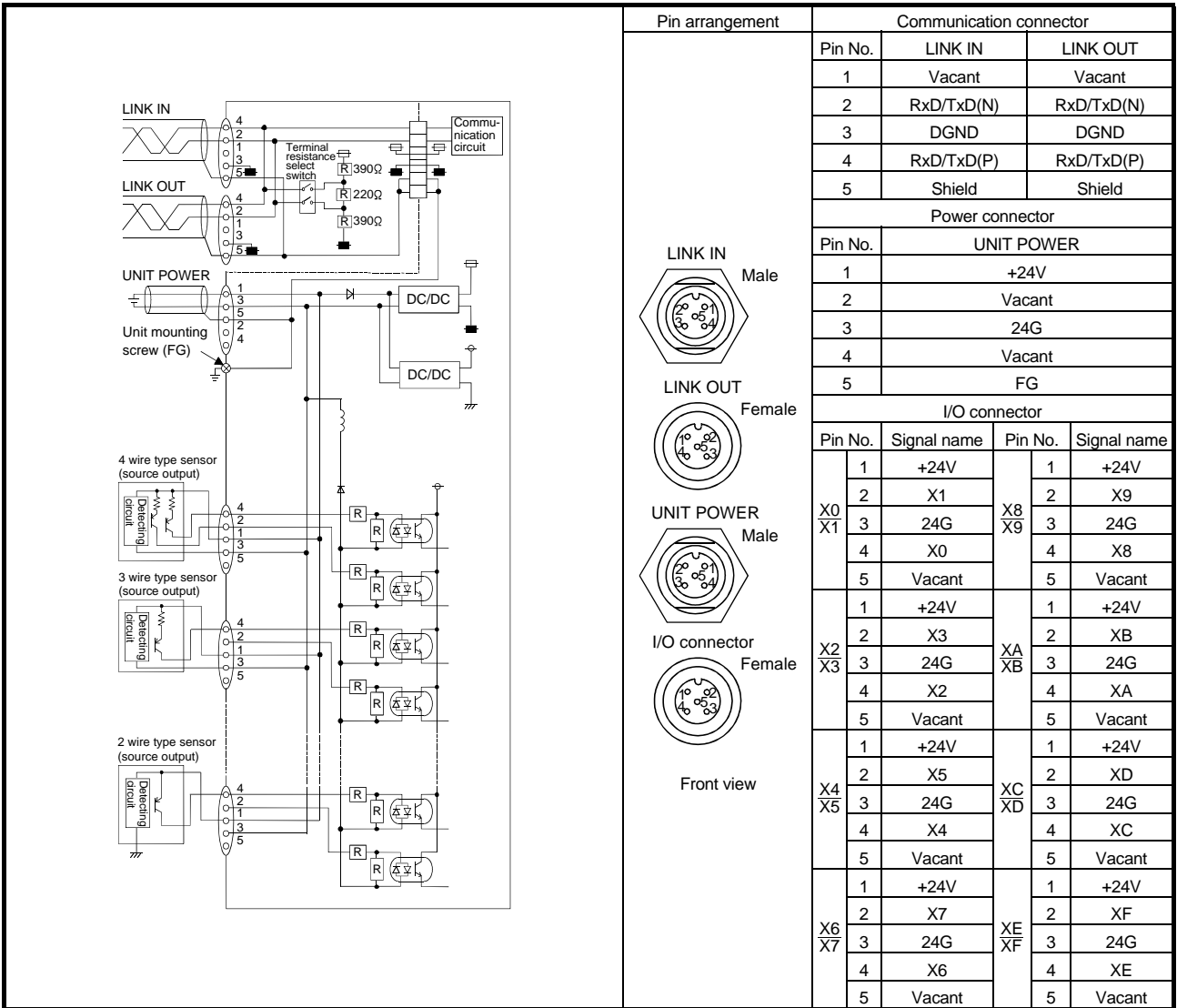

Pin arrangement		Communication connector			
		Pin No.	LINK IN	LINK OUT	
		1	Vacant	Vacant	
		2	RxD/TxD(N)	RxD/TxD(N)	
		3	DGND	DGND	
		4	RxD/TxD(P)	RxD/TxD(P)	
		5	Shield	Shield	
		Power connector			
		Pin No.	UNIT POWER		
		1	+24V		
		2	Vacant		
		3	24G		
		4	Vacant		
		5	FG		
		I/O connector			
		Pin No.	Signal name	Pin No.	Signal name
X0 X1	1	+24V	X8 X9	1	+24V
	2	X1		2	X9
	3	24G		3	24G
	4	X0		4	X8
	5	Vacant		5	Vacant
X2 X3	1	+24V	XA XB	1	+24V
	2	X3		2	XB
	3	24G		3	24G
	4	X2		4	XA
	5	Vacant		5	Vacant
X4 X5	1	+24V	XC XD	1	+24V
	2	X5		2	XD
	3	24G		3	24G
	4	X4		4	XC
	5	Vacant		5	Vacant
X6 X7	1	+24V	XE XF	1	+24V
	2	X7		2	XF
	3	24G		3	24G
	4	X6		4	XE
	5	Vacant		5	Vacant

5 OUTPUT MODULE SPECIFICATION

Specification of the output module that can be connected to the PROFIBUS-DP network is described.

5.1 AJ95TB2-16T Output Module

Specification		AJ95TB2-16T Output Module
Number of input points		16 points
Insulation method		Photocoupler insulation
Rated load voltage		12/24VDC
Max. load current		0.8A/1point 3.2A/common
Max. inrush current		8A 10msec or less
Leakage current at OFF circuit		0.1mA or less
Max. voltage drop at ON circuit		1.5V or less (0.8A Max.)
Output method		Source type
Response time	OFF → ON	2msec or less
	ON → OFF	2msec or less (load resistance)
Output area external power supply	Voltage range	10.8VDC to 26.4VDC (peak voltage 30V)
	Current consumption	35mA TYP. (no load, all points ON)
Surge absorber		Zener diode with built-in FET
Fuse rating		Fuse 5A (1/common) Not replacement
Common method		8 points/common (COM1+ 8 terminals, COM2+ 8 terminals)
Number of occupied station		1 station
I/O module power supply	Voltage	15.6VDC to 31.2VDC (peak voltage)
	Current	188mA (24.0VDC)
Noise durability		First transient burst noise (IEC801-4) 2kV DC type noise voltage 500Vp-p Noise width 1μs, Noise frequency 25 to 60Hz (noise simulator condition)
Withstanding voltage		500VAC for 1 minute between all DC external terminals together and ground.
Insulation resistance		10MΩ or higher, measured with a 500VAC insulation resistance tester.
Weight kg (lb)		0.45 (0.99)
External connection method	I/O, power supply	Insertion type terminal board (M2.5 flat head machine screw) Specified torque range 0.25 to 0.35N·m
	FG	M4 Phillips-head and flat-head screw terminal Specified torque range 1.00 to 1.35N·m Applicable crimp terminal RAV1.25-4, RAV2-4
	Transmission circuit	9-pin D-SUB connector (receptacle)
Applicable electric wire size		0.18 to 2mm ² (single wire or twisted wire)
Module mounting screws		M4 × 0.7 × 16mm or larger screws (Specified torque range 0.78 to 1.18N·m) Mounting by DIN rail also possible.
Applicable DIN rail		TH35-7.5Fe, TH35-7.5Al, TH35-15Fe (Conforms to JIS-C2812 or DIN, EN, IEC standard 35mm wide top hat rail)

External connection

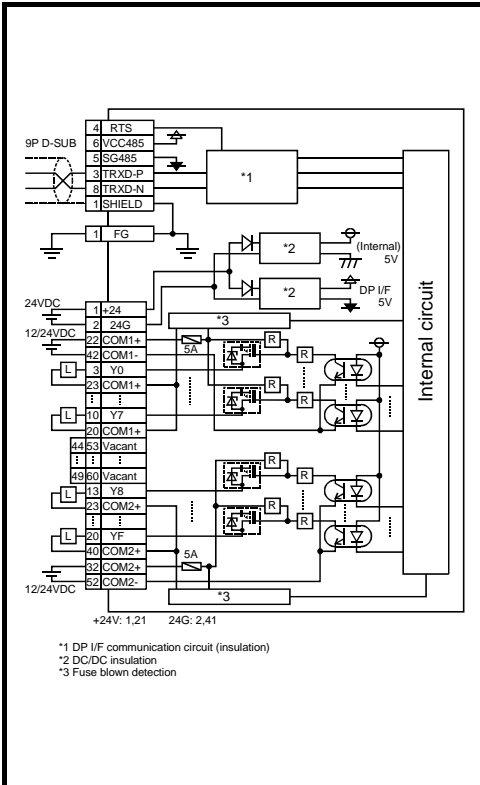

Terminal No.	Signal name	Terminal No.	Signal name	Terminal No.	Signal name
TB1	+24V	TB21	+24V	TB41	24G
TB2	24G	TB22	COM1+	TB42	COM1-
TB3	Y0	TB23	COM1+	TB43	COM1+
TB4	Y1	TB24	COM1+	TB44	NC
TB5	Y2	TB25	COM1+	TB45	NC
TB6	Y3	TB26	COM1+	TB46	NC
TB7	Y4	TB27	COM1+	TB47	NC
TB8	Y5	TB28	COM1+	TB48	NC
TB9	Y6	TB29	COM1+	TB49	NC
TB10	Y7	TB30	COM1+	TB50	COM1+
TB11	COM1+	TB31	COM1+	TB51	COM1-
TB12	COM2+	TB32	COM2+	TB52	COM2-
TB13	Y8	TB33	COM2+	TB53	NC
TB14	Y9	TB34	COM2+	TB54	NC
TB15	YA	TB35	COM2+	TB55	NC
TB16	YB	TB36	COM2+	TB56	NC
TB17	YC	TB37	COM2+	TB57	NC
TB18	YD	TB38	COM2+	TB58	NC
TB19	YE	TB39	COM2+	TB59	NC
TB20	YF	TB40	COM2+	TB60	NC

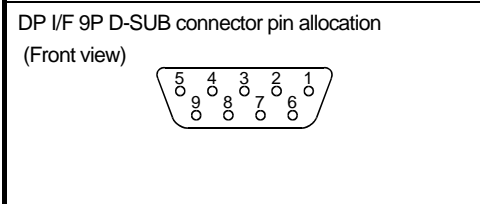

No.	Signal name	No.	Signal name
1	SHIELD	6	VCC485
2	NC	7	NC
3	TRXD-P	8	TRXD-N
4	RTS	9	NC
5	SG485		

5

5.2 AJ65FBTA2-16TE Transistor Output Module (Source type)

Specification		AJ65FBTA2-16TE Output module
Number of output points		16 points
Isolation method		Photocoupler
Rated load voltage		12 - 24VDC
Operating load voltage range		10.2 to 28.8VDC (ripple ratio : within 5 %)
Max. load current		0.5A/point 2.4A/common
Max. load inrush current		1.0A 10ms or lower
Leakage current at OFF		0.25mA or lower
Max. voltage drop at ON		0.15VDC or lower (TYP) 0.5A 0.25VDC or lower (MAX) 0.5A
Response time	OFF → ON	0.5ms or lower
	ON → OFF	1.5ms or lower (resistive load)
Output method		Source type
Protection function		Yes (thermal protection short circuit protections) <ul style="list-style-type: none"> • Thermal protection is activated in increments of 1 points. • Short circuit protection is activated in increments of 1 points. • Lights up when the output section protection function is working. (During the protect operation, fuse interruption is searched in the master unit side.) • Automatic reset
External Power supply for output	Voltage	10.2 to 28.8VDC (ripple ratio : within 5%)
	Current	10mA or lower (When 24VDC and all point is ON) Not including external load current
Surge suppressor		Zener diode
Common wiring method		16 points/1 common (waterproof connector 2-wire type)
Number of stations occupied		1 station 32 points assignment (use 16points)
I/O module power supply	Voltage	20.4 to 26.4VDC (ripple ratio : within 5%)
	Current	50mA or lower (When 24VDC and all point is on)
Noise durability		DC type noise withstand voltage 500Vp-p noise width 1 μ s, noise carrier frequency 25 to 60Hz (noise simulator condition)
Withstand voltage		500VAC for 1 minute between all DC external terminals and ground
Insulation resistance		10 M Ω or higher, measured with a 500VDC insulation resistance tester
Protection of degree		IP67
Weight		0.40kg
Option		Waterproof cap : A6CAP-WP2

External Connections

The schematic diagram illustrates the internal and external connections of the output module. It includes sections for LINK IN and LINK OUT with terminal resistances (390Ω and 220Ω) and a terminal resistance select switch. The UNIT POWER section shows a DC/DC converter and a constant voltage circuit. The AUX. section shows a terminal block with pins 1, 2, 3, and 4. The Load power section shows three identical load circuits, each with a terminal block (pins 1, 2, 3, 4) and a load (L). A communication circuit is also shown at the top right.

Pin arrangement		Communication connector	
Pin No.	LINK IN	LINK OUT	
1	Vacant	Vacant	
2	RxD/TxD(N)	RxD/TxD(N)	
3	DGND	DGND	
4	RxD/TxD(P)	RxD/TxD(P)	
5	Shield	Shield	
Power connector			
Pin No.	UNIT POWER	AUX.	
1	+24V	+24V	
2	Vacant	Vacant	
3	24G	24G	
4	Vacant	Vacant	
5	FG	FG	
I/O connector			
Pin No.	Signal name	Pin No.	Signal name
Y0 Y1	1	1	Vacant
	2	2	Y9
	3	3	24G
	4	4	Y8
	5	5	Vacant
Y2 Y3	1	1	Vacant
	2	2	YB
	3	3	24G
	4	4	YA
	5	5	Vacant
Y4 Y5	1	1	Vacant
	2	2	YD
	3	3	24G
	4	4	YC
	5	5	Vacant
Y6 Y7	1	1	Vacant
	2	2	YF
	3	3	24G
	4	4	YE
	5	5	Vacant

Pin arrangement diagrams (Front view):

- LINK IN Male: 5-pin connector with pins 1, 2, 3, 4, 5.
- LINK OUT Female: 5-pin connector with pins 1, 2, 3, 4, 5.
- UNIT POWER Male: 5-pin connector with pins 1, 2, 3, 4, 5.
- I/O connector Female: 5-pin connector with pins 1, 2, 3, 4, 5.

6 COMPOSITE MODULE SPECIFICATION

Specification of the compound module that can be connected to the PROFIBUS-DP network is described.

6.1 AJ95TB32-16DT Composite Module

AJ95TB32-16DT Composite Module			
Input specification	Number of input points		8 points
	Insulation method		Photocoupler insulation
	Rated input voltage		24VDC
	Rated input current		Approx. 7mA
	External supply input voltage		19.2 to 26.4VDC (ripple: less than 5%)
	Max. simultaneous input points		100% (8 points) simultaneously ON
	ON voltage/ON current		14V or higher/3.5mA or higher
	OFF voltage/OFF current		6V or lower/1.7mA or less
	Input impedance		Approx. 3.3k Ω
	Response time	OFF→ON	10msec or less
		ON→OFF	10msec or less (load resistance)
	Common method		8 points/common (COM2+ 8 terminals, COM2- 8 terminals)
	Input method		Sink/Source common type
Output specification	Number of output points		8 points
	Insulation method		Photocoupler insulation
	Rated load voltage		12V/24V
	External power supply	Voltage range	10.8VDC to 26.4VDC (peak voltage 30V)
		Current consumption	18mA TYP. (no load, all points ON)
	Max. load current		0.8A/1 point 3.2A/common
	Max. inrush current		8A 10msec or less
	Leakage current at OFF circuit		0.1mA or less
	Max. voltage drop at ON circuit		1.5V or less (0.8A Max.)
	Surge absorber		Zener diode with built-in FET
	Response time	OFF→ON	2msec or less
		ON→OFF	2msec or less (load resistance)
	Fuse rating		5A (1/common) Not replacement
	Common method		8 points/common (COM1+ 8 terminals)
	Output method		Source type
Number of occupied station		1 station	
I/O module power supply	Voltage	15.6VDC to 31.2VDC (peak voltage)	
	Current	183mA (24.0VDC)	
Noise durability		First transient burst noise (IEC801-4) 2kV DC type noise voltage 500p-p Noise width 1 μ s, Noise frequency 25 to 60Hz (noise simulator condition)	
Withstanding voltage		500VAC for 1 minute between all DC external terminals together and ground.	
Insulation resistance		10M Ω or higher, measured with a 500VAC insulation resistance tester.	
Weight kg (lb)		0.45 (0.99)	
External connection method	I/O, power supply	Insertion type terminal board (M2.5 flat head machine screw) Specified torque range 0.25 to 0.35N·m Applicable crimp terminal RAV1.25-4, RAV2-4	
	FG	M4 Phillips-head and flat-head screw terminal Spcified torque range 1.00 to 1.35N·m Applicable crimp terminal RAV1.25-4, RAV2-4	
	Transmission circuit	9-pin D-SUB connector (receptacle)	
Applicable electric wire size		0.18 to 2mm ²	
Module mounting screws		M4 × 0.7 × 16mm or larger screws (Specified torque range 0.78 to 1.18N·m) Mounting by DIN rail also possible.	

External connection

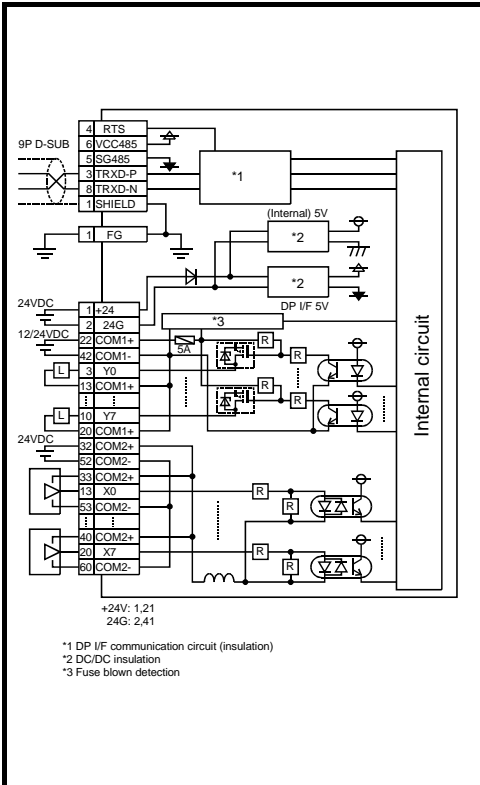

Terminal No.	Signal name	Terminal No.	Signal name	Terminal No.	Signal name
TB1	+24V	TB21	+24V	TB41	24G
TB2	24G	TB22	COM1+	TB42	COM1-
TB3	Y0	TB23	COM1+	TB43	COM1+
TB4	Y1	TB24	COM1+	TB44	NC
TB5	Y2	TB25	COM1+	TB45	NC
TB6	Y3	TB26	COM1+	TB46	NC
TB7	Y4	TB27	COM1+	TB47	NC
TB8	Y5	TB28	COM1+	TB48	NC
TB9	Y6	TB29	COM1+	TB49	NC
TB10	Y7	TB30	COM1+	TB50	COM1+
TB11	COM1+	TB31	COM1+	TB51	COM1-
TB12	NC	TB32	COM2+	TB52	COM2-
TB13	X0	TB33	COM2+	TB53	COM2-
TB14	X1	TB34	COM2+	TB54	COM2-
TB15	X2	TB35	COM2+	TB55	COM2-
TB16	X3	TB36	COM2+	TB56	COM2-
TB17	X4	TB37	COM2+	TB57	COM2-
TB18	X5	TB38	COM2+	TB58	COM2-
TB19	X6	TB39	COM2+	TB59	COM2-
TB20	X7	TB40	COM2+	TB60	COM2-

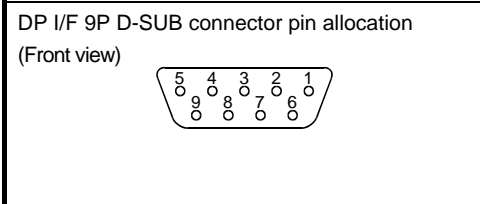

No.	Signal name	No.	Signal name
1	SHIELD	6	VCC485
2	NC	7	NC
3	TRXD-P	8	TRXD-N
4	RTS	9	NC
5	SG485		

6.2 AJ95FPBA42-16DTE Composite Module

Specification		AJ95FPBA42-16DTE Composite Module	
Input specification	Number of output points	8 points	
	Isolation method	Photocoupler	
	Rated input voltage	24VDC	
	Rated input current	Approx. 7mA	
	Operating voltage range	20.4 to 26.4VDC (ripple ratio : within 5 %)	
	Max. simultaneous ON input points	100 %	
	ON voltage/ ON current	14V or higher/3.5mA or higher	
	OFF voltage/ OFF current	6V or lower/1.7mA or lower	
	Input resistance	Approx. 3.3k Ω	
	Response time	OFF \rightarrow ON	1.5ms or lower (when 24VDC)
		ON \rightarrow OFF	1.5ms or lower (when 24VDC)
	Input form	Negative common (Source type)	
	Common wiring method	8 points/1 common (waterproof connector 2 to 4-wire type)	
	Output specification	Number of output points	8 points
Isolation method		Photocoupler	
Rated load voltage		24VDC	
Operating load voltage range		20.4 to 26.4VDC (ripple ratio : within 5 %)	
Max. load current		0.5A/point 2.4A/common	
Max. load inrush current		1.0A 10ms or lower	
Leakage current at OFF		0.25mA or lower	
Max. voltage drop at ON		0.15VDC or lower (TYP) 0.5A	
		0.25VDC or lower (MAX) 0.5A	
Response time		OFF \rightarrow ON	0.5ms or lower
		ON \rightarrow OFF	1.5ms or lower (resistive load)
Output method	Source type		
Protection function		Yes (thermal protection short circuit protections) <ul style="list-style-type: none"> • Thermal protection is activated in increments of 1 points. • Short circuit protection is activated in increments of 1 points. • Lights up when the output section protection function is working. (During the protect operation, fuse interruption is searched in the master unit side.) • Automatic reset 	
External Power supply for output	Voltage	20.4 to 26.4VDC (ripple ratio : within 5%)	
	Current	10mA or lower (When 24VDC and all point is ON) Not including external load current	
Surge suppressor		Zener diode	
Common wiring method		8 points/1 common (waterproof connector 2-wire type)	
Number of stations occupied		1 station 32 points assignment (use 16points)	
I/O module power supply	Voltage	20.4 to 26.4VDC (ripple ratio : within 5%)	
	Current	45mA or lower (When 24VDC and all point is on)	
Noise durability		DC type noise withstand voltage 500Vp-p noise width 1 μ s, noise carrier frequency 25 to 60Hz (noise simulator condition)	
Withstand voltage		500VAC for 1 minute between all DC external terminals and ground	
Insulation resistance		10 M Ω or higher, measured with a 500VDC insulation resistance tester	
Protection of degree		IP67	
Weight		0.40kg	
Accessory		User's Manual	
Option		Waterproof cap : A6CAP-WP2	

External Connections

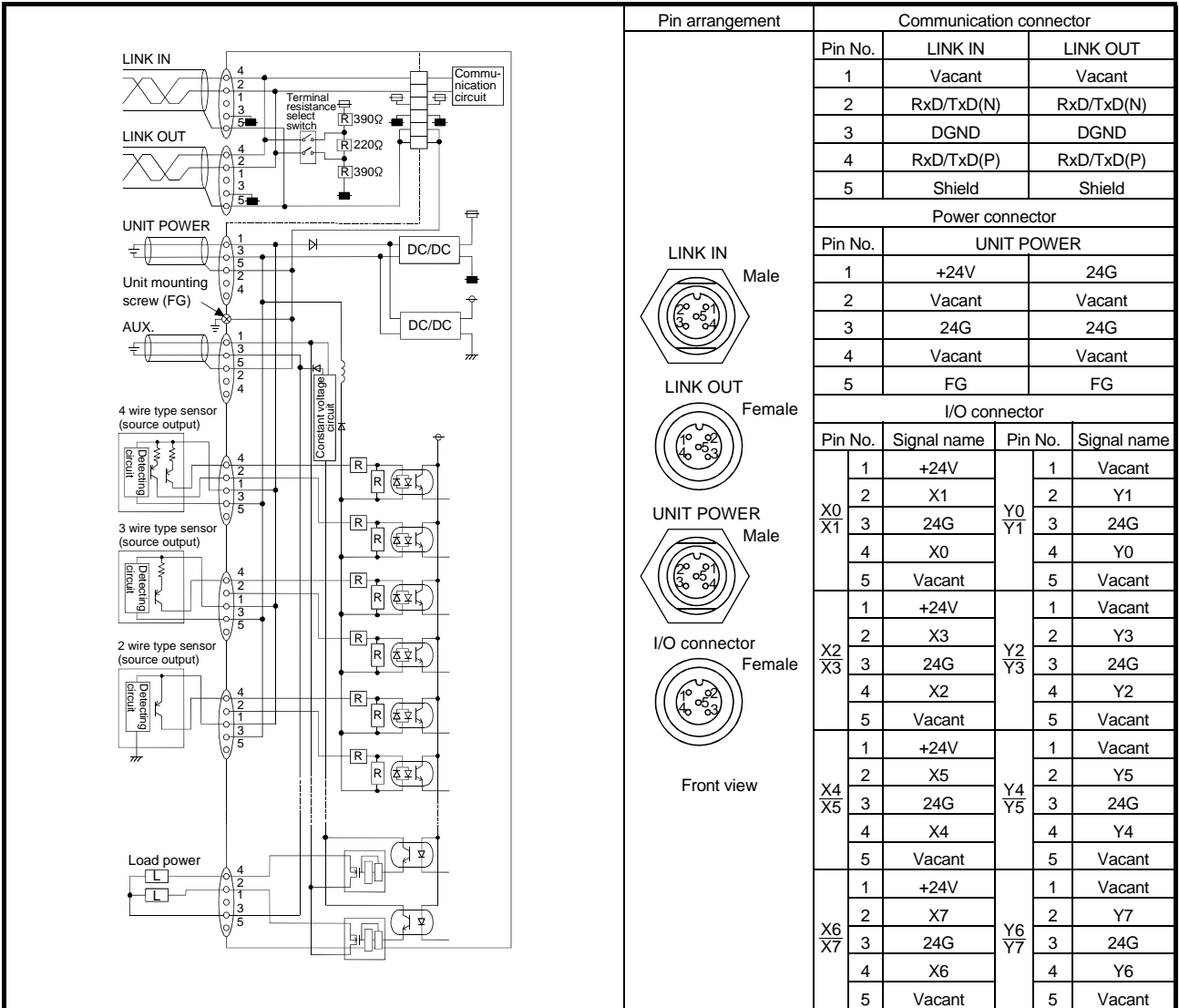

Pin arrangement		Communication connector	
Pin No.		LINK IN	LINK OUT
1		Vacant	Vacant
2		RxD/TxD(N)	RxD/TxD(N)
3		DGND	DGND
4		RxD/TxD(P)	RxD/TxD(P)
5		Shield	Shield
Power connector			
Pin No.	UNIT POWER		
1	+24V	24G	
2	Vacant	Vacant	
3	24G	24G	
4	Vacant	Vacant	
5	FG	FG	
I/O connector			
Pin No.	Signal name	Pin No.	Signal name
X0 X1	1 +24V	Y0 Y1	1 Vacant
	2 X1		2 Y1
	3 24G		3 24G
	4 X0		4 Y0
	5 Vacant		5 Vacant
X2 X3	1 +24V	Y2 Y3	1 Vacant
	2 X3		2 Y3
	3 24G		3 24G
	4 X2		4 Y2
	5 Vacant		5 Vacant
X4 X5	1 +24V	Y4 Y5	1 Vacant
	2 X5		2 Y5
	3 24G		3 24G
	4 X4		4 Y4
	5 Vacant		5 Vacant
X6 X7	1 +24V	Y6 Y7	1 Vacant
	2 X7		2 Y7
	3 24G		3 24G
	4 X6		4 Y6
	5 Vacant		5 Vacant

7 HANDLING THE SLAVE I/O MODULE

7.1 Precautions When Handling or Installing the Slave I/O Module

Precautions when handling or installing the slave I/O module on the PROFIBUS-DP network are described.

 **DANGER**

- Do not touch terminal or connectors while the power is ON.
This will cause electric shock or malfunctions.

 **CAUTION**

- Use the module in an environment that conforms to the general specifications in the CPU module user's manual.
Using the module in environments outside the ranges stated in the general specifications will cause electric shock, fire, malfunction, or damage to/deterioration of the product.
- Firmly fasten the module with the DIN rail, or mounting screws, and tighten the mounting screws to within the specified torque range.
If the mounting screws are loose, the module may fall out or short circuit.
If the mounting screws are too tight, the screw may break and cause the module fall out or short circuit.
- Perform correct pressure-displacement, crimp-contact or soldering for wire connections using the tools specified by the manufacturers.
Attach connectors to the module securely.
Incomplete connection for the connectors may cause malfunctions or short circuit.
- Make sure that no foreign matter such as chips or wiring offcuts gets inside the module.
It will cause electric shock or malfunctions.
- Do not disassemble or modify the module.
This will cause failure, malfunction, injuries, or fire.
- The module case is made of plastic. Do not drop it or subject it to strong shock.
The module may break.
- Do not separate the printed wiring board of the module from the case, as this can result in a breakdown.
- Always turn off all the power phases at the outside before installing or removing the module to or from the panel. If all the phases are not turned off, the module may fail or operate erroneously.
- Set the connection switch of the terminal resistor before starting the operation.
Setting the switch while in operation may cause a network error, and such errors may not be detected.

7

- (1) Tighten the module installation screws and terminal block screws with the following torque:

Screw location	Tightening torque range
Module installation screw (M4)	0.78 to 1.18N · m
Terminal block screw for I/O and power supply (M2.5)	0.25 to 0.35N · m
Terminal block installation screw (M3.5)	0.55 to 0.75N · m
FG terminal screw (M4)	1.00 to 1.35N · m

- (2) If a DIN rail adapter is used, take note on the following when installing the DIN rail:
 - (a) Applicable DIN rail models (a 35mm(1.38inch)-wide top hat rail which conforms to the JIS-C2812 or DIN, EN, and IEC standards)
TH35-7.5Fe
TH35-7.5Al
TH35-15Fe
 - (b) DIN rail installation screw intervals
When installing a DIN rail, keep 200mm(7.87inch) or smaller intervals between the screws.
- (3) For the specification of the cables supported by the slave I/O module, refer to Chapter 2 "Name and Setting of Each area."
- (4) The shielded cable must be used for I/O signal lines that are pulled out from the control panel for usage and PROFIBUS-DP communication lines.
As for shielding, be sure to ground partially peeled area of the shield with a maximum available area to the control panel at a location near the exit of the control panel.
Refer to the CPU User's Manual (Hardware Edition) for standards regarding EMC and precautions when making an equipment.
(Standards regarding EMC : EMI standard EN50081-2, EMS standard EN50082-2)
- (5) Avoid the following environment for the installation location of the slave I/O module:
 - (a) Where ambient temperature may exceed 55°C
 - (b) Where ambient temperature may exceed the range 10 to 90%RH
 - (c) Where condensation occurs due to sudden temperature changes
 - (d) Where corrosive gas or flammable gas exists
 - (e) Where there exists excessive dust, conductive particles such as iron chips, oil mist, salt, or organic solvent
 - (f) Area exposed to direct sunlight
 - (g) Where strong electric or magnetic field generates
 - (h) Where vibration or shock is directly applied to the main unit
- (6) When installing the slave I/O module to a panel, etc., secure a 80mm clearance between the top/bottom of the module and other structure or parts to assure good ventilation and ease module replacement works.
- (7) Install each slave I/O module to a flat surface.
If the installation surface has bumps and dips, excessive force will be applied to the PCB, which may cause malfunctions.
- (8) To use the terminal resistor, set the "terminal resistor connect/not connect switch" of the slave I/O module end station to ON.
(Instead, set to OFF for the slave I/O modules other than the end station.)
- (9) Do not connect anything to NC terminal.

7.2 Connection Method

The connection method between the master module and slave I/O module using twisted pair cable are described.

⚠ DANGER

- Completely turn off the external power when installing or placing wiring. Not completely turning off all power could result in electric shock or damage to the product.
- Switch all phases of the external power supply off before cleaning or re-tightening terminal screws. Not doing so could result in electric shock. If the screws are loose, the module may fall out, short circuit, or malfunction. If the screws are too tight, the module may fall out, short circuit, or malfunction.

⚠ CAUTION

- Be sure to ground the FG terminal to the protected grounding conductor. Otherwise there will be a danger of malfunctions or fire.
- Carry out wiring to the module correctly, checking the rated voltage and terminal arrangement of the product. Using a power supply that does not conform to the rated voltage, or carrying out wiring incorrectly, will cause fire or failure.
- Tighten the terminal screws within the specified tighten torque range. Loose terminal screws may cause a short circuit, fire, or malfunctions. If the screws are too tight, the screws may break and cause a short circuit, fire, or malfunctions.
- Do not bundle control lines or communication wires together with main circuit or power lines, or lay them close to these lines. As a guide, separate the lines by a distance of at least 100 mm (3.94 inch), otherwise malfunctions may occur due to noise.
- Make sure the connector of each connection cable is installed securely in its installation section. Defective contact may cause malfunctioning.

The following shows how to connect between the master module and slave I/O module:

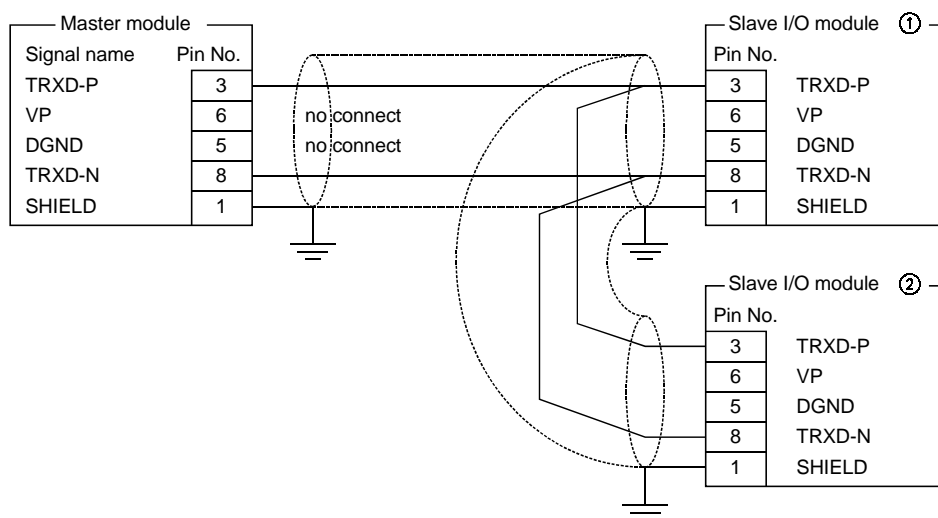

7.3 Installing Slave I/O Module to DIN Rail (AJ95TB □ -16□)

The installation and removal methods of the module to/from the DIN rail are described.

(1) Installing the slave I/O module to DIN rail

- 1) Set the groove of the upper hook of the module to the top of the DIN rail.
- 2) Press the module against the DIN rail and hook the lower hook.

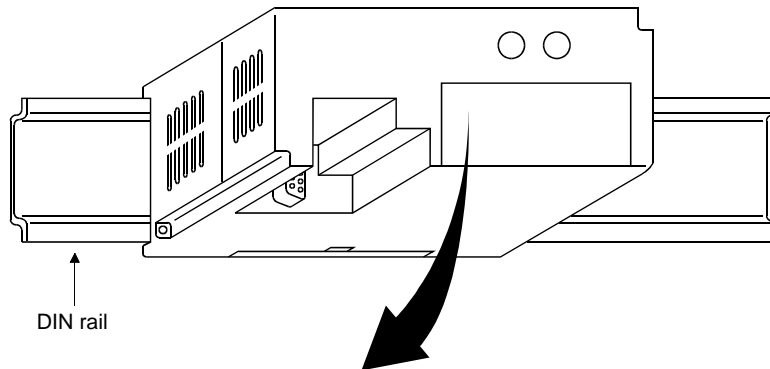

(2) Removing the slave I/O module from DIN rail

- 1) Pull out the lower hook of the module using a screwdriver (for flat-head screw).
- 2) With the lower hook pulled out, pull the module toward the front.

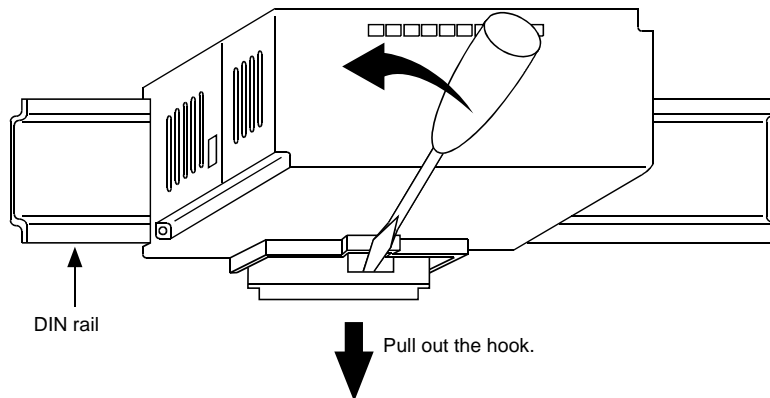

7.4 Handling of the Low Profile Waterproof Type Slave I/O Module

7.4.1 List of model names of waterproof caps

The model name of the waterproof cap applicable to the low profile waterproof type slave I/O module (AJ95FPBA□-16□) is shown below.

	Mitsubishi Product Model Name	Use
Waterproof Cap (20 pcs., Sold separately)	A6CAP-WP2	For Link Out connector, I/O Connector

POINT
<ul style="list-style-type: none"> • Cannot be used with the previous type of waterproof cap (A6CAP-WP1).

7.4.2 Waterproof cap installation method

The installation method for the waterproof caps packed with the product is shown below.

In order to prevent water penetration, install the waterproof caps on the unused Link Out side connectors and I/O connectors using the following method.

- 1) Insert the waterproof cap in the empty connector on the main module, then tighten it.
Tightening Torque Range: 0.29 to 0.34 N·m

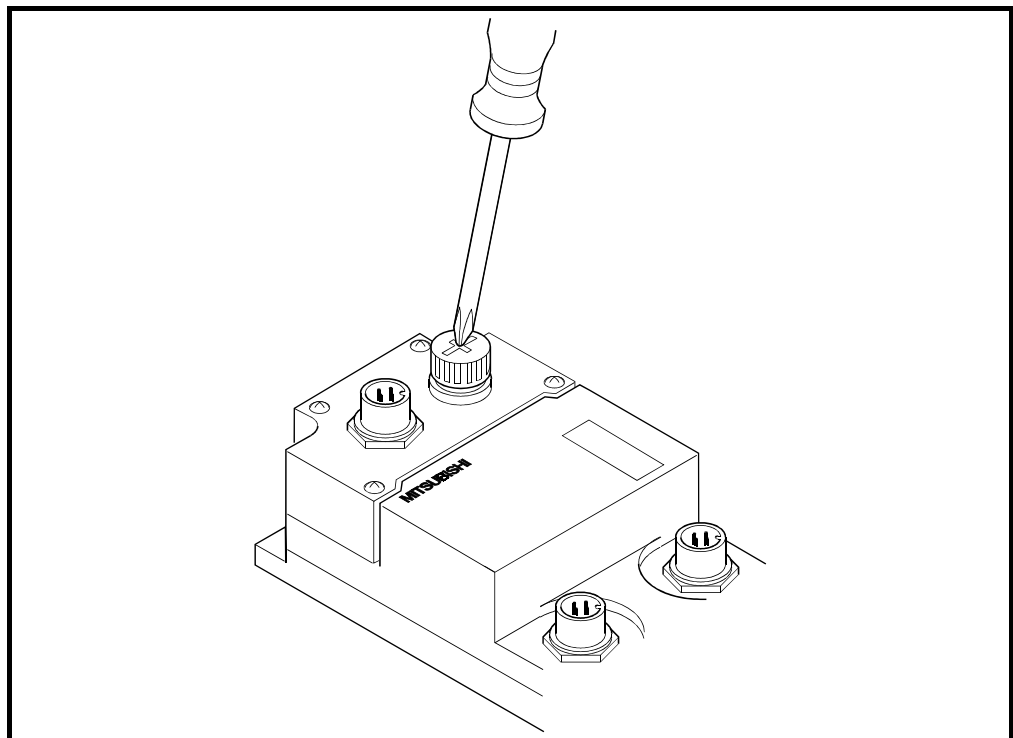

8 SLAVE I/O MODULE TROUBLE EXAMPLES

Examples of troubles occurred in the I/O circuit and their countermeasures are described.

8.1 Examples and Countermeasures of Troubles in Input Circuit

Examples of troubles occurred in the input circuit and their countermeasures are described.

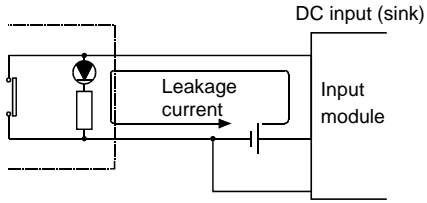
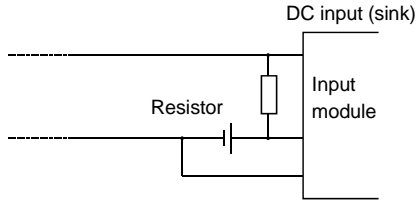
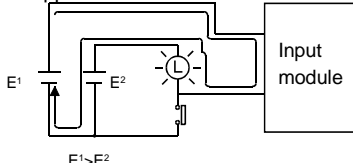
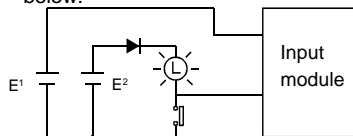
	Symptom	Cause	Countermeasure
Example 1	Input signal does not turn off.	<ul style="list-style-type: none"> It is driven by a switch with the LED display. 	<ul style="list-style-type: none"> Connect an appropriate resistor so that the voltage between the input module terminal and the common exceeds the OFF voltage as shown below:  <p>* Sample calculation to obtain the resistor value to be connected is shown on the next page.</p>
Example 2	Input signal does not turn off.	<ul style="list-style-type: none"> Current escape due to the use of two power supplies 	<ul style="list-style-type: none"> Integrate the two power supplies into one. Connect an escape-proof diode as shown below: 

<Sample calculation for example 4>

When the switch with LED display is connected to AJ95TB-16D and 4mA of current leakage exists:

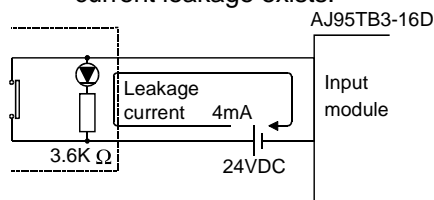

- (1) The OFF current of the AJ95TB-16D does not turn off because the value 1mA is not satisfied.

So, connect a resistor as shown below:

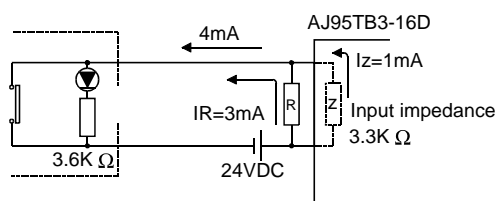

- (2) Calculating connected resistor value R is to obtain resistance R so that current flows by 3mA to the connected resistor in order to satisfy the 1mA OFF current at the AJ95TB3-16D:

$I_R : I_Z = Z$ (input impedance) : R

$$R \leq \frac{I_Z}{I_R} \times (\text{input impedance}) = \frac{1}{3} \times 3.3 = 1.1 [\text{k}\Omega]$$

Therefore,

$$R < 1.1 \text{k}\Omega$$

Given $1 \text{k}\Omega$ as resistance R, the power capacity W of resistance R becomes:

$$W = (\text{Input voltage})^2 / R = 26.4^2 / 1000 = 0.7 \text{ (W)}$$

- (3) Power capacity of resistance is selected three to five times the actual consumed power. Therefore, $1 [\text{k}\Omega]^2$ to $3 [\text{W}]$ of resistance should be connected to the terminal in question.

APPENDIX

Appendix 1 External Dimensions Diagram

Appendix 1.1 The AJ95TB3-16D module

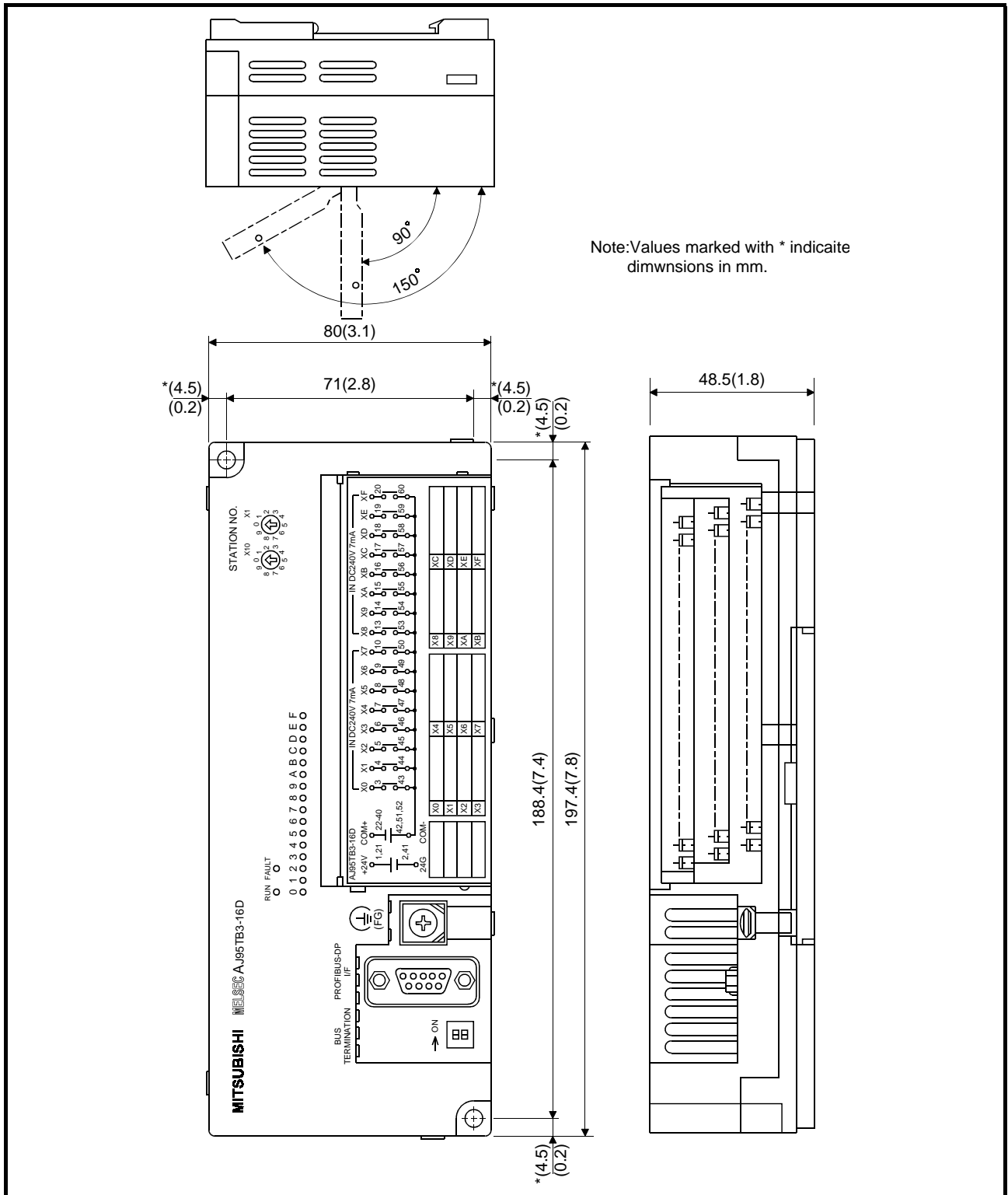

Appendix 1.2 The AJ95TB2-1T module

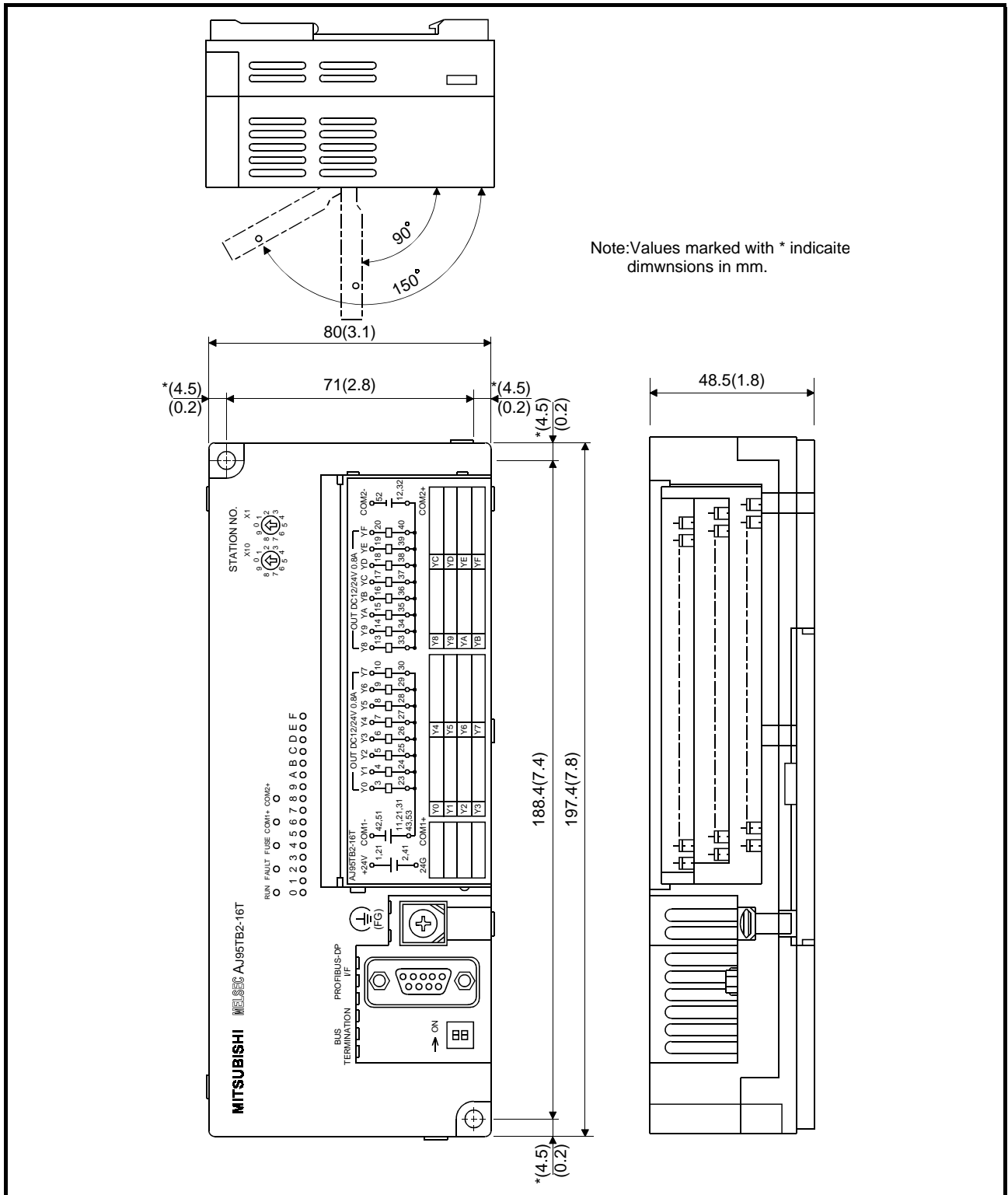

Note: Values marked with * indicate dimensions in mm.

APP

Appendix 2 DDB File

Appendix 2.1 AJ95TB3-16D

To generate the AJ95TB3-16D communication parameters with configurator, an AJ95TB3-16D DDB file is necessary. A commercial editor is used to generate and use the following DDB file contents.

```

;*****
; Device Data Base for AJ95TB3-16D
;*****
;
#Profibus_DP
GSD_Revision          =      1
;
Vendor_Name           =      "MITSUBISHI ELECTRIC CORPORATION"
Model_Name            =      "AJ35TB3-16D"
Revision              =      "revision G52"
Ident_Number          =      0xF035
Protocol_Ident        =      0
Station_Type          =      0
FMS_supp              =      0
Hardware_Release      =      "A"
Software_Release      =      "none"
;
9.6_supp              =      1
19.2_supp             =      1
93.75_supp            =      1
187.5_supp            =      1
500_supp              =      1
1.5M_supp             =      1
3M_supp               =      1
6M_supp               =      1
12M_supp              =      1
;
MaxTsdR_9.6           =      60
MaxTsdR_19.2          =      60
MaxTsdR_93.75         =      60
MaxTsdR_187.5         =      60
MaxTsdR_500           =      100
MaxTsdR_1.5M          =      150
MaxTsdR_3M            =      250
MaxTsdR_6M            =      450
MaxTsdR_12M           =      800
;
Redundancy            =      1
Repeater_Ctrl_Sig     =      1
24V_Pins              =      0
Implementation_Type   =      "implementation type"
Bitmap_Device         =      "bmpdev.dib"
Bitmap_Diag           =      "bmpdia.dib"
Bitmap_SF              =      "bmpsf.dib"
;
Freeze_Mode_supp      =      1
Sync_Mode_supp        =      1
Auto_Baud_supp        =      1
Set_Slave_Add_supp    =      1
Min_Slave_Intervall   =      65535
;
Modular_Station       =      0
Modul_Offset          =      255
;
Fail_Safe              =      1
Slave_Family           =      3
Max_Diag_Data_Len     =      8
;
;
Module = "aj95tb3-16d" 0x00
1
EndModule
;

```

Appendix 2.2 AJ95TB2-16T

To generate the AJ95TB3-16D communication parameters with configurator, an AJ95TB3-16D DDB file is necessary. A commercial editor is used to generate and use the following DDB file contents.

```

;*****
; Device Data Base for AJ95TB2-16T
;*****
;
#Profibus_DP
GSD_Revision          =      1
;
Vendor_Name           =      "MITSUBISHI ELECTRIC CORPORATION"
Model_Name            =      "AJ35TB3-16T"
Revision              =      "revision G52"
Ident_Number          =      0xF034
Protocol_Ident        =      0
Station_Type          =      0
FMS_supp              =      0
Hardware_Release      =      "A"
Software_Release      =      "none"
;
9.6_supp              =      1
19.2_supp             =      1
93.75_supp            =      1
187.5_supp            =      1
500_supp              =      1
1.5M_supp             =      1
3M_supp               =      1
6M_supp               =      1
12M_supp              =      1
;
MaxTsdr_9.6           =      60
MaxTsdr_19.2          =      60
MaxTsdr_93.75         =      60
MaxTsdr_187.5         =      60
MaxTsdr_500           =      100
MaxTsdr_1.5M          =      150
MaxTsdr_3M            =      250
MaxTsdr_6M            =      450
MaxTsdr_12M           =      800
;
Redundancy             =      1
Repeater_Ctrl_Sig     =      1
24V_Pins              =      0
Implementation_Type   =      "implementation type"
Bitmap_Device         =      "bmpdev.dib"
Bitmap_Diag           =      "bmpdia.dib"
Bitmap_SF              =      "bmpsfd.dib"
;
Freeze_Mode_supp      =      1
Sync_Mode_supp        =      1
Auto_Baud_supp         =      1
Set_Slave_Add_supp    =      1
Min_Slave_Intervall   =      65535
;
Modular_Station        =      0
Modul_Offset           =      255
;
Fail_Safe              =      1
Slave_Family           =      3
Max_Diag_Data_Len     =      8
;
;
Module = "aj95tb2-16t" 0x10
1
EndModule
;

```

Appendix 2.3 AJ95TB32-16DT

To generate the AJ95TB3-16D communication parameters with configurator, an AJ95TB3-16D DDB file is necessary. A commercial editor is used to generate and use the following DDB file contents.

```

;*****
; Device Data Base for AJ95TB32-16DT
;*****
;
#Profibus_DP
GSD_Revision      =      1
;
Vendor_Name       =      "MITSUBISHI ELECTRIC CORPORATION"
Model_Name        =      "AJ35TB3-16DT"
Revision          =      "revision G52"
Ident_Number      =      0xF033
Protocol_Ident    =      0
Station_Type      =      0
FMS_supp          =      0
Hardware_Release  =      "A"
Software_Release  =      "none"
;
9.6_supp          =      1
19.2_supp         =      1
93.75_supp        =      1
187.5_supp        =      1
500_supp          =      1
1.5M_supp         =      1
3M_supp           =      1
6M_supp           =      1
12M_supp          =      1
;
MaxTsd_r_9.6      =      60
MaxTsd_r_19.2     =      60
MaxTsd_r_93.75    =      60
MaxTsd_r_187.5    =      60
MaxTsd_r_500      =      100
MaxTsd_r_1.5M     =      150
MaxTsd_r_3M       =      250
MaxTsd_r_6M       =      450
MaxTsd_r_12M      =      800
;
Redundancy        =      1
Repeater_Ctrl_Sig =      1
24V_Pins          =      0
Implementation_Type = "implementation type"
Bitmap_Device     =      "bmpdev.dib"
Bitmap_Diag       =      "bmpdia.dib"
Bitmap_SF         =      "bmprsf.dib"
;
Freeze_Mode_supp  =      1
Sync_Mode_supp    =      1
Auto_Baud_supp    =      1
Set_Slave_Add_supp =      1
Min_Slave_Intervall = 65535
;
Modular_Station   =      0
Modul_Offset      =      255
;
Fail_Safe         =      1
Slave_Family      =      3
Max_Diag_Data_Len =      8
;
;
Module = "aj95tb32-16dt" 0x11
1
EndModule
;

```

Appendix 2.4 AJ95FPBA4-16DE

To generate the AJ95FPBA4-16DE communication parameters with configurator, an AJ95FPBA4-16DE DDB file is necessary. A commercial editor is used to generate and use the following DDB file contents.

```

;*****
; Device Data Base for AJ95FPBA4-16DE
;*****
;
#Profibus_DP
GSD_Revision          =      1
;
Vendor_Name           =      "MITSUBISHI ELECTRIC CORPORATION"
Model_Name            =      "AJ95FPBA4-16DE      16 DI"
Revision              =      "MEU-GER V1.0"
Ident_Number          =      0x060A
Protocol_Ident        =      0
Station_Type          =      0
FMS_supp              =      0
Hardware_Release      =      "A"
Software_Release      =      "none"
;
9.6_supp              =      1
19.2_supp             =      1
93.75_supp            =      1
187.5_supp            =      1
500_supp              =      1
1.5M_supp             =      1
3M_supp               =      1
6M_supp               =      1
12M_supp              =      1
MaxTsdr_9.6           =      60
MaxTsdr_19.2          =      60
MaxTsdr_93.75         =      60
MaxTsdr_187.5         =      60
MaxTsdr_500           =      100
MaxTsdr_1.5M          =      150
MaxTsdr_3M            =      250
MaxTsdr_6M            =      450
MaxTsdr_12M           =      800
;
Redundancy            =      0
Repeater_Ctrl_Sig     =      1
24V_Pins              =      0
;Implementation_Type =      "implementation type"
;Bitmap_Device        =      "bmpdev.dib"
;Bitmap_Diag          =      "bmpdia.dib"
;Bitmap_SF            =      "bmpsf.dib"
;
Freeze_Mode_supp      =      1
Sync_Mode_supp        =      1
Auto_Baud_supp        =      1
Set_Slave_Add_supp    =      0
User_Prm_Data_Len     =      5
User_Prm_Data         =      0x00,0x00,0x00,0x00,0x00
Min_Slave_Intervall   =      1
;
Modular_Station       =      0
Modul_Offset          =      255
;
Fail_Safe              =      1
Slave_Family           =      3
Max_Diag_Data_Len     =      8
;
;
Module = "aj95fpba4-16de" 0x00,0x11
1
EndModule
;

```

Appendix 2.5 AJ95FPBA2-16TE

To generate the AJ95FPBA2-16TE communication parameters with configurator, an AJ95FPBA2-16TE DDB file is necessary. A commercial editor is used to generate and use the following DDB file contents.

```

;*****
; Device Data Base for AJ95FPBA2-16TE
;*****
;
#Profibus_DP
GSD_Revision          =      1
;
Vendor_Name           =      "MITSUBISHI ELECTRIC CORPORATION"
Model_Name            =      "AJ95FPBA2-16TE      16 DO"
Revision              =      "MEU-GER V1.0"
Ident_Number         =      0x060B
Protocol_Ident       =      0
Station_Type         =      0
FMS_supp             =      0
Hardware_Release     =      "A"
Software_Release     =      "none"
;
9.6_supp             =      1
19.2_supp            =      1
93.75_supp           =      1
187.5_supp           =      1
500_supp             =      1
1.5M_supp            =      1
3M_supp              =      1
6M_supp              =      1
12M_supp             =      1
MaxTsdr_9.6         =      60
MaxTsdr_19.2        =      60
MaxTsdr_93.75       =      60
MaxTsdr_187.5       =      60
MaxTsdr_500         =      100
MaxTsdr_1.5M        =      150
MaxTsdr_3M          =      250
MaxTsdr_6M          =      450
MaxTsdr_12M         =      800
;
Redundancy           =      0
Repeater_Ctrl_Sig   =      1
24V_Pins             =      0
;Implementation_Type =      "implementation type"
;Bitmap_Device      =      "bmpdev.dib"
;Bitmap_Diag        =      "bmpdia.dib"
;Bitmap_SF          =      "bmssf.dib"
;
Freeze_Mode_supp    =      1
Sync_Mode_supp      =      1
Auto_Baud_supp      =      1
Set_Slave_Add_supp  =      0
User_Prm_Data_Len   =      05
User_Prm_Data       =      0x00,0x00,0x00,0x00,0x00
Min_Slave_Intervall =      1
;
Modular_Station     =      0
Modul_Offset        =      255
;
Fail_Safe           =      1
Slave_Family        =      3
Max_Diag_Data_Len   =      8
Unit_Diag_Bit(0)    =      "Protect circuit channel Y0-F"
;
;
Module = "aj95fpba2-16te" 0x21,0x00
1
EndModule
;

```

Appendix 2.6 AJ95FPBA42-16DTE

To generate the AJ95FPBA42-16DTE communication parameters with configurator, an AJ95FPBA42-16DTE DDB file is necessary. A commercial editor is used to generate and use the following DDB file contents.

```

;*****
; Device Data Base for AJ95FPBA42-16DTE
;*****
;
#Profibus_DP
GSD_Revision          =      1
;
Vendor_Name           =      "MITSUBISHI ELECTRIC CORPORATION"
Model_Name            =      "AJ95FPBA42-16DTE 8 DI / 8DO"
Revision              =      "MEU-GER V1.0"
Ident_Number          =      0x0609
Protocol_Ident        =      0
Station_Type          =      0
FMS_supp              =      0
Hardware_Release      =      "A"
Software_Release      =      "none"
;
9.6_supp              =      1
19.2_supp             =      1
93.75_supp            =      1
187.5_supp            =      1
500_supp              =      1
1.5M_supp             =      1
3M_supp               =      1
6M_supp               =      1
12M_supp              =      1
MaxTsdr_9.6           =      60
MaxTsdr_19.2          =      60
MaxTsdr_93.75         =      60
MaxTsdr_187.5         =      60
MaxTsdr_500           =      100
MaxTsdr_1.5M          =      150
MaxTsdr_3M            =      250
MaxTsdr_6M            =      450
MaxTsdr_12M           =      800
;
Redundancy             =      0
Repeater_Ctrl_Sig     =      1
24V_Pins              =      0
;Implementation_Type =      "implementation type"
;Bitmap_Device         =      "bmpdev.dib"
;Bitmap_Diag           =      "bmpdia.dib"
;Bitmap_SF             =      "bmssf.dib"
;
; Slave specific Values
;
Freeze_Mode_supp      =      1
Sync_Mode_supp        =      1
Auto_Baud_supp        =      1
Set_Slave_Add_supp    =      0
User_Prm_Data_Len     =      05
User_Prm_Data         =      0x00,0x00,0x00,0x00,0x00
Min_Slave_Intervall   =      1
;
Modular_Station       =      0
Modul_Offset          =      255
;
Fail_Safe              =      1
Slave_Family           =      3
Max_Diag_Data_Len     =      8
Unit_Diag_Bit(0)     =      "Protect circuit channel Y0-7"
;
;
Module = "aj95fpba42-16dte" 0x20,0x10
1
EndModule

```

HEADQUARTERS

MITSUBISHI ELECTRIC EUROPE
EUROPE B.V.
German Branch
Gothaer Straße 8
D-40880 Ratingen
Phone: +49 (0) 21 02 / 486-0
Fax: +49 (0) 21 02 / 4 86-11 20
e mail: megfamail@meg.mee.com

MITSUBISHI ELECTRIC FRANCE
EUROPE B.V.
French Branch
25, Boulevard des Bouvets
F-92741 Nanterre Cedex
Phone: +33 1 55 68 55 68
Fax: +33 1 55 68 56 85
e mail: factory.automation@fra.mee.com

MITSUBISHI ELECTRIC UK
EUROPE B.V.
UK Branch
Travellers Lane
GB-Hatfield Herts. AL10 8 XB
Phone: +44 (0) 1707 / 27 61 00
Fax: +44 (0) 1707 / 27 86 95

MITSUBISHI ELECTRIC ITALY
EUROPE B.V.
Italian Branch
Via Paracelso 12
I-20041 Agrate Brianza (MI)
Phone: +39 039 6053 1
Fax: +39 039 6053 312
e mail: factory.automation@it.mee.com

MITSUBISHI ELECTRIC SPAIN
EUROPE B.V.
Spanish Branch
Carretera de Rubí 76-80
E-08190 Sant Cugat del Vallés
Phone: +34 9 3 / 565 3131
Fax: +34 9 3 / 589 2948
e mail: industrial@sp.mee.com

MITSUBISHI ELECTRIC JAPAN
CORPORATION
Office Tower "Z" 14 F
8-12,1 chome, Harumi Chuo-Ku
Tokyo 104-6212
Phone: +81 3 6221 6060
Fax: +81 3 6221 6075

MITSUBISHI ELECTRIC USA
AUTOMATION
500 Corporate Woods Parkway
Vernon Hills, IL 60061
Phone: +1 847 / 478 21 00
Fax: +1 847 / 478 22 83

EUROPEAN REPRESENTATIVES

GEVA AUSTRIA
Wiener Straße 89
A-2500 Baden
Phone: +43 (0) 2252 / 85 55 20
Fax: +43 (0) 2252 / 488 60
e mail: office@geva.at

TEHNIKON BELARUS
Oktjabskaya 16/5, Ap 704
BY-220030 Minsk
Phone: +375 (0) 17 / 22 75 704
Fax: +375 (0) 17 / 22 76 669
e mail: tehnikon@belsonet.net

Getronics b.v. BELGIUM
Control Systems
Pontbeeklaan 43
B-1731 Asse-Zellik
Phone: +32 (0) 2 / 467 17 51
Fax: +32 (0) 2 / 467 17 45
e mail: infoautomation@getronics.com

TELECON CO. BULGARIA
4, A. Ljapchev Blvd.
BG-1756 Sofia
Phone: +359 (0) 2 / 97 44 05 8
Fax: +359 (0) 2 / 97 44 06 1
e mail: —

INEA CR d.o.o. CROATIA
Drvinje 63
HR-10000 Zagreb
Phone: +385 (0) 1 / 36 67 140
Fax: +385 (0) 1 / 36 67 140
e mail: —

AutoCont CZECHIA
Control Systems s.r.o.
Nemocnicni 12
CZ-702 00 Ostrava 2
Phone: +420 59 / 6152 111
Fax: +420 59 / 6152 562
e mail: consys@autocont.cz

louis poulsen DENMARK
industri & automation
Geminevej 32
DK-2670 Greve
Phone: +45 (0) 43 / 95 95 95
Fax: +45 (0) 43 / 95 95 91
e mail: lpia@lpmail.com

UTU Elektrotehnika AS ESTONIA
Pärnu mnt.160i
EE-11317 Tallinn
Phone: +372 (0) 6 / 51 72 80
Fax: +372 (0) 6 / 51 72 88
e mail: utu@utu.ee

Beijer Electronics OY FINLAND
Ansatie 6a
FIN-01740 Vantaa
Phone: +358 (0) 9 / 886 77 500
Fax: +358 (0) 9 / 886 77 555
e mail: info@beijer.fi

PROVENDOR OY FINLAND
Teljänkatu 8 A 3
FIN-28130 Pori
Phone: +358 (0) 2 / 522 3300
Fax: +358 (0) 2 / 522 3322
e mail: —

UTECO A.B.E.E. GREECE
5, Mavrogenous Str.
GR-18542 Piraeus
Phone: +302 (0) 10 / 42 10 050
Fax: +302 (0) 10 / 42 12 033
e mail: uteco@uteco.gr

Meltrade Automatika Kft. HUNGARY
55, Harmat St.
HU-1105 Budapest
Phone: +36 (0)1 / 2605 602
Fax: +36 (0)1 / 2605 602
e mail: office@meltrade.hu

EUROPEAN REPRESENTATIVES

MITSUBISHI ELECTRIC IRELAND
EUROPE B.V. – Irish Branch
Westgate Business Park
IRL-Dublin 24
Phone: +353 (0) 1 / 419 88 00
Fax: +353 (0) 1 / 419 88 90
e mail: sales.info@meir.mee.com

SIA POWEL LATVIA
Lienes iela 28
LV-1009 Riga
Phone: +371 784 / 22 80
Fax: +371 784 / 22 81
e mail: utu@utu.lv

UAB UTU POWEL LITHUANIA
Savanoriu pr. 187
LT-2053 Vilnius
Phone: +370 (0) 52323-101
Fax: +370 (0) 52322-980
e mail: powel@utu.lt

INTEHSIS SRL MOLDOVA
Cuza-Voda 36/1-81
MD-2061 Chisinau
Phone: +373 (0)2 / 562 263
Fax: +373 (0)2 / 562 263
e mail: intehsis@mdl.net

Getronics b.v. NETHERLANDS
Control Systems
Donauweg 2 B
NL-1043 AJ Amsterdam
Phone: +31 (0) 20 / 587 67 00
Fax: +31 (0) 20 / 587 68 39
e mail: info.gia@getronics.com

Beijer Electronics AS NORWAY
Teglværksveien 1
N-3002 Drammen
Phone: +47 (0) 32 / 24 30 00
Fax: +47 (0) 32 / 84 85 77
e mail: info@beijer.no

MPL Technology Sp. z o.o. POLAND
ul. Sliczna 36
PL-31-444 Kraków
Phone: +48 (0) 12 / 632 28 85
Fax: +48 (0) 12 / 632 47 82
e mail: krakow@mpl.pl

Sirius Trading & Services srl ROMANIA
Bd. Lacul Tei nr. 1 B
RO-72301 Bucuresti 2
Phone: +40 (0) 21 / 201 7147
Fax: +40 (0) 21 / 201 7148
e mail: sirius_t_s@fx.ro

ACP Autocomp a.s. SLOVAKIA
Chalupkova 7
SK-81109 Bratislava
Phone: +421 (02) / 5292-22 54, 55
Fax: +421 (02) / 5292-22 48
e mail: info@acp-autocomp.sk

INEA d.o.o. SLOVENIA
Stegne 11
SI-1000 Ljubljana
Phone: +386 (0) 1-513 8100
Fax: +386 (0) 1-513 8170
e mail: inea@inea.si

Beijer Electronics AB SWEDEN
Box 426
S-20124 Malmö
Phone: +46 (0) 40 / 35 86 00
Fax: +46 (0) 40 / 35 86 02
e mail: info@beijer.se

ECONOTEC AG SWITZERLAND
Postfach 282
CH-8309 Nürensdorf
Phone: +41 (0) 1 / 838 48 11
Fax: +41 (0) 1 / 838 48 12
e mail: info@econotec.ch

EUROPEAN REPRESENTATIVES

GTS TURKEY
Darülaceze Cad. No. 43 KAT: 2
TR-80270 Okmeydani-Istanbul
Phone: +90 (0) 212 / 320 1640
Fax: +90 (0) 212 / 320 1649
e mail: gts@turk.net

CSC Automation Ltd. UKRAINE
15, M. Raskova St., Fl. 10, Office 1010
UA-02002 Kiev
Phone: +380 (0) 44 / 238-83-16
Fax: +380 (0) 44 / 238-83-17
e mail: csc-a@csc-a.kiev.ua

AFRICAN REPRESENTATIVE

CBI Ltd SOUTH AFRICA
Private Bag 2016
ZA-1600 Isando
Phone: +27 (0) 11 / 928 2000
Fax: +27 (0) 11 / 392 2354
e mail: cbi@cbi.co.za

MIDDLE EAST REPRESENTATIVE

TEXEL Electronics LTD. ISRAEL
Box 6272
IL-42160 Netanya
Phone: +972 (0) 9 / 863 08 91
Fax: +972 (0) 9 / 885 24 30
e mail: texel_me@netvision.net.il

EURASIAN REPRESENTATIVE

AVTOMATIKA SEVER RUSSIA
Krapivnijn Per. 5, Of. 402
RU-194044 St Petersburg
Phone: +7 812 / 1183 238
Fax: +7 812 / 3039 648
e mail: pav@avtsev.spb.ru

CONSYS RUSSIA
Promyshlennaya St. 42
RU-198099 St Petersburg
Phone: +7 812 / 325 36 53
Fax: +7 812 / 325 36 53
e mail: consys@consys.spb.ru

ELEKTROSTYLE RUSSIA
Ul Garschina 11
RU-140070 Moscovskaja Oblast
Phone: +7 095 / 261 3808
Fax: +7 095 / 261 3808
e mail: —

ICOS RUSSIA
Industrial Computer Systems Zao
Ryazanskij Prospekt 8a, Office 100
RU-109428 Moscow
Phone: +7 095 / 232 - 0207
Fax: +7 095 / 232 - 0327
e mail: mail@icos.ru

NPP Uralelektra RUSSIA
Sverdlova 11a
RU-620027 Ekaterinburg
Phone: +7 34 32 / 53 27 45
Fax: +7 34 32 / 53 27 45
e mail: elektra@etel.ru

STC Drive Technique RUSSIA
Poslannikov Per. 9, str.1
RU-107005 Moscow
Phone: +7 095 / 786 21 00
Fax: +7 095 / 786 21 01
e mail: info@privod.ru