



General-Purpose AC Servo

MELSERVO-JN Series

General-Purpose Interface Servo Amplifier

MODEL (Servo Amplifier)

MR-JN-□A

MODEL (Servo Motor)

HF-KN□

HF-KP□G1/G5/G7



INSTRUCTION MANUAL

● Safety Instructions ●

(Always read these instructions before using the equipment.)





Be sure to read through this Instruction Manual, Installation guide and appended documents carefully before using the equipment. For your protection, do not install, operate, inspect or perform maintenance procedures until you have a full knowledge of the equipment and the safety information and instructions.

In this Instruction Manual, the safety instruction levels are classified into "WARNING" and "CAUTION".

 WARNING	Indicates that incorrect handling may cause hazardous conditions, resulting in death or severe injury.
 CAUTION	Indicates that incorrect handling may cause hazardous conditions, resulting in medium or slight injury to personnel or may cause physical damage.

Note that the  CAUTION level may lead to a serious consequence according to conditions. Please follow the instructions of both levels because they are important to personnel safety.

What must not be done and what must be done are indicated by the following diagrammatic symbols.

 : Indicates what must not be done. For example, "No Fire" is indicated by  .
 : Indicates what must be done. For example, grounding is indicated by  .

In this Instruction Manual, instructions at a lower level than the above, instructions for other functions, and so on are classified into "POINT".

After reading this installation guide, always keep it accessible to the operator.

1. To prevent electric shock, note the following

 **WARNING**

- Before wiring, be sure to turn off the power, wait for 15 minutes or longer, and then make sure that the charge lamp is off to prevent an electric shock. In addition, always confirm if the charge lamp is off or not from the front of the servo amplifier.
- Ground the servo amplifier and the servo motor securely.
- Only qualified personnel should attempt wiring and inspection.
- Wire the servo amplifier and the servo motor after installation is complete to prevent an electric shock.
- Do not operate the switches with wet hands as it may cause an electric shock.
- Do not damage, stress excessively, place heavy objects or pinch the cable to prevent an electric shock.

2. To prevent fire, note the following

 **CAUTION**

- Install the servo amplifier, the servo motor and the regenerative option on incombustible material. Installing them directly or close to combustibles may cause a fire.
- Connect a magnetic contactor (MC) between the main circuit power supply, and L₁ and L₂ of the servo amplifier to configure a circuit that shuts off the power on the servo amplifier's power supply side. If a magnetic contactor (MC) is not connected, continuous flow of a large current may cause a fire when the servo amplifier malfunctions.
- When using a regenerative resistor, configure a circuit that shuts off the power if abnormality is found. Otherwise, the regenerative resistor may overheat, causing a fire due to a regenerative transistor fault.
- When using a regenerative option, remove the built-in regenerative resistor and its wiring from the servo amplifier.
- Provide an adequate protection to prevent conductive matters such as screws or metal pieces or combustible matters such as oil from entering the servo amplifier and the servo motor.
- Always connect a no-fuse breaker to the power supply of the servo amplifier.

3. To prevent injury, note the follow

 **CAUTION**

- Do not apply voltage other than specified in this Instruction Manual to each terminal as it may cause burst, damage, etc.
- Connect the wires to correct terminals to prevent burst, damage, etc.
- Ensure that polarity (+, -) is correct. Otherwise, a burst, damage, etc. may occur.
- The servo amplifier heat sink, the regenerative option, the servo motor can be very hot during power-on and for some time after power-off, and it may result burns or damages to parts (cables, etc.) Take measures, e.g. provide covers, to prevent accidental contact of hands and parts with them.
- Never touch the rotating parts of the servo motor during operation as it may cause injury.

4. Additional instructions

The following instructions should also be fully noted. Incorrect handling may cause a fault, injury, electric shock, etc.

(1) Transportation and installation

CAUTION

- Carry the products in a suitable way according to their weights.
- Do not stack the product packages exceeding the maximum number specified on the package.
- Do not hold the lead of the built-in regenerative resistor when carrying the servo amplifier.
- Do not hold the cable, the shaft or the encoder when carrying the servo motor.
- Install the equipment on a weight-bearing place in accordance with this Instruction Manual.
- Do not get on or place heavy objects on the equipment.
- Install the equipment in the specified direction. Improper installation causes oil leakage, leading to a fire and malfunction.
- Leave specified clearances between the servo amplifier and inner wall of the control box or other equipment.
- Do not block the intake/exhaust ports of the servo amplifier. Otherwise, a fault may occur.
- Do not install or operate a servo amplifier and a servo motor which are damaged or have any part missing.
- Do not drop or shock the servo amplifier or the servo motor as they are precision equipment.
- When storing the equipment, please fulfill the following environmental conditions.

Item			Environmental conditions			
			Servo amplifier	Servo motor		
Ambient temperature	In operation	[°C]	0 to + 55 (non-freezing)	0 to + 40 (non-freezing)		
	In storage	[°C]	− 20 to + 65 (non-freezing)	− 15 to + 70 (non-freezing)		
Ambient humidity	In operation		90%RH or less (non-condensing)	80%RH or less (non-condensing)		
	In storage			90%RH or less (non-condensing)		
Ambience			Indoors (no direct sunlight) Free from corrosive gas, flammable gas, oil mist, dust and dirt			
Altitude			Max. 1000m (3280 ft) above sea level			
Vibration			5.9 m/s ² or less, 10 to 55Hz (directions of X, Y, and Z axes)		HF-KN Series	X ▪ Y: 49m/s ²
					HF-KP Series (Note)	

Note. For the standard servo motor (without reduction gear.)

- Couple the servo motor to a machine securely. Insecure coupling may cause the servo motor to come off.
- Be sure to measure the motor vibration level with the servo motor mounted to the machine when checking the vibration level. A great vibration may cause the early damage of a bearing, encoder, brake, and reduction gear. The great vibration may also cause the poor connector connection or bolt looseness.
- For the gain adjustment at the equipment startup, check the torque waveform and the speed waveform by using a measurement device, and then check that no vibration occurs. If the vibration occurs due to high gain, the vibration may cause the early damage of the servo motor.
- Install the servo motor with a reduction gear in the specified direction to prevent oil leakage.
- Take safety measures, e.g. provide covers, to prevent accidental access to the rotating parts of the servo motor during operation.
- Never hit the servo motor or shaft, especially when coupling the servo motor to a machine as it may damage the encoder.
- Do not apply load exceeding the permissible load as it may break the shaft.
- When the equipment has been stored for an extended period of time, contact your local sales office.
- When handling the servo amplifier, be careful with the edged parts such as the corners of the servo amplifier.
- Be sure to install the servo amplifier in a metal control box.

(2) Wiring

⚠ CAUTION

- Before unplugging CNP1 connector from the servo amplifier, disconnect the lead of the built-in regenerative resistor from CNP1 connector first.
- Wire the equipment correctly and securely. Improper wiring may cause unexpected operation.
- Do not install a power capacitor, a surge killer or a radio noise filter (optional FR-BIF) between the servo motor and the servo amplifier.
- Connect the wires to the correct phase terminals (U, V, W) of the servo amplifier and the servo motor. Not doing so may cause unexpected operation.
- Connect the servo motor power terminals (U, V, W) of the servo amplifier to the servo motor power input terminals (U, V, W) directly. Do not install a magnetic contactor, etc. between the servo amplifier and the servo motor.

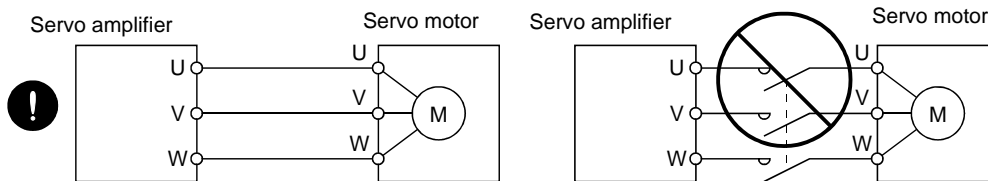

- Do not connect AC power supply directly to the servo motor. Otherwise, a fault may occur.
- Install a surge absorbing diode on the DC relay designed for control output signal in the specified direction. Improper installation of the surge absorbing diode may cause the servo amplifier to malfunction such that the signals are not output, and emergency stop and other safety circuits are inoperable.

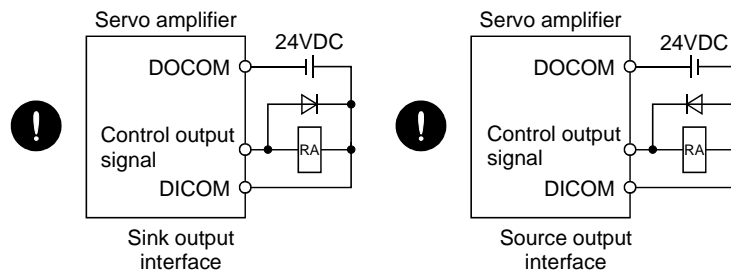

(3) Test run adjustment

⚠ CAUTION

- Check and adjust the parameter setting before operation. Improper settings may cause some machines to perform unexpected operation.
- Never adjust or change the parameter values extremely as it will make operation instable.

(4) Usage

⚠ CAUTION

- Configure an external emergency stop circuit in order to stop the operation immediately and shut off the power.
- Do not disassemble or repair the equipment.
- If an alarm is reset while the operation signal is input to the servo amplifier, the equipment starts suddenly. Be sure that the operation signal is off before resetting the alarm to prevent an accident.
- Do not modify the equipment.
- Electromagnetic interference from the servo amplifier may affect the surrounding electronic equipment. Minimize the influence of the electromagnetic interference by using a noise filter, etc.
- Toxic gases may be generated by burning or disassembling the servo amplifier. Do not burn or disassemble the servo amplifier.
- Use the servo amplifier with the specified servo motor.
- The electromagnetic brake on the servo motor is designed to hold the motor shaft and should not be used for ordinary braking.
- For such reasons as service life and mechanical structure (e.g. where a ball screw and the servo motor are coupled via a timing belt), the electromagnetic brake may not hold the motor shaft. To ensure safety, install a stopper on the machine side.

(5) Corrective actions

⚠ CAUTION

- When it is assumed that a hazardous condition may take place at the occur due to a power failure or a product fault, use a servo motor with an electromagnetic brake or provide an external brake mechanism for the purpose of prevention.
- Configure the electromagnetic brake operation circuit which interlocks with an external emergency stop switch.

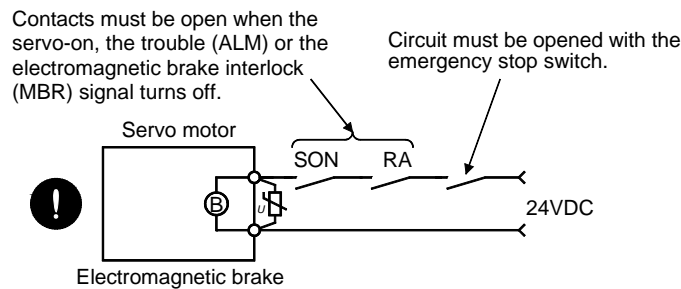

- When an alarm occurs, remove its cause. Then, ensure safety and reset the alarm before restarting operation.
- When power is restored after an instantaneous power failure, keep away from the machine because the machine may be restarted suddenly. (Design the machine so that it is secured against hazard if restarted.)

(6) Storing of servo motor

CAUTION

- Note the following points when storing the servo motor for an extended period of time (guideline: three or more months).
- Be sure to store the servo motor indoors in a clean and dry place.
- If it is stored in a dusty or damp place, make adequate provision, e.g. cover the whole product.
- If the insulation resistance of the winding decreases, reexamine the storage method.
- Though the servo motor is rust-proofed before shipment using paint or rust prevention oil, rust may be produced depending on the storage conditions or storage period. If the servo motor is to be stored for longer than six months, apply rust prevention oil again especially to the machined surfaces of the shaft, etc.
- Before using the servo motor that has been stored for an extended period of time, hand-turn the servo motor output shaft to confirm that nothing is wrong with the servo motor. (For the servo motor with an electromagnetic brake, turn ON the power supply of the electromagnetic brake, first. Then, release the electromagnetic brake before hand-turn.)
- When the equipment has been stored for an extended period of time, contact your local sales office.

(7) Maintenance, inspection and parts replacement

CAUTION

- With age, the electrolytic capacitor of the servo amplifier will deteriorate. To prevent a secondary accident due to a fault, it is recommended to replace the electrolytic capacitor every 10 years when used in general environment. Please contact your local sales office.

(8) General instruction

- To illustrate details, the equipment in the diagrams of this Instruction Manual may have been drawn without covers and safety guards. When the equipment is operated, the covers and safety guards must be installed as specified. Operation must be performed in accordance with this Instruction Manual.

● About processing of waste ●

When you discard converter unit, servo amplifier, servo motor, battery (primary battery), and other option articles, please follow the law of each country (area).



FOR MAXIMUM SAFETY

- These products have been manufactured as a general-purpose part for general industries, and have not been designed or manufactured to be incorporated in a device or system used in purposes related to human life.
- Before using the products for special purposes such as nuclear power, electric power, aerospace, medicine, passenger movement vehicles or under water relays, contact Mitsubishi.
- These products have been manufactured under strict quality control. However, when installing the product where major accidents or losses could occur if the product fails, install appropriate backup or failsafe functions in the system.



EEP-ROM life

The number of write times to the EEP-ROM, which stores parameter settings, etc., is limited to 100,000. If the total number of the following operations exceeds 100,000, the converter unit, servo amplifier (drive unit) and/or converter unit may fail when the EEP-ROM reaches the end of its useful life.

- Write to the EEP-ROM due to parameter setting changes
- Write to the EEP-ROM due to device changes
- Write to the EEP-ROM due to point table changes
- Write to the EEP-ROM due to program changes
- Write to the EEP-ROM due to data records with drive recorder

Precautions for Choosing the Products

Mitsubishi will not be held liable for damage caused by factors found not to be the cause of Mitsubishi; machine damage or lost profits caused by faults in the Mitsubishi products; damage, secondary damage, accident compensation caused by special factors unpredictable by Mitsubishi; damages to products other than Mitsubishi products; and to other duties.

COMPLIANCE WITH EC DIRECTIVES

Refer to appendix 7 for the compliance with EC directives.

CONFORMANCE WITH UL/CSA STANDARD

Refer to appendix 8 for the conformance with UL/CSA standard.

<<About the manuals>>

Relevant manuals

Manual name	Manual No.
MELSERVO-JN Series Instructions and Cautions for Safe Use of AC Servos (Enclosed in servo amplifier.)	IB(NA)0300157
QUICK INSTALLATION GUIDE	L(NA)03052ENG
MELSERVO Servo Motor Instruction Manual Vol.2	SH(NA)030041
EMC Installation Guidelines	IB(NA)67310

<<About the wires used for wiring>>

Wiring wires mentioned in this instruction manual are selected based on the ambient temperature of 40°C (104°F).

Introduction

The Mitsubishi MELSERVO-JN series general-purpose AC servo is based on the MELSERVO-J3 series, and retains its high performance, with some limitations in functions. For details of functions, performance and specifications of the MELSERVO-JN series, refer to chapters 1 to 13 and appendices of this Instruction Manual. This section describes the how-to (startup, actual operation, and others) for users who use the MELSERVO-JN series AC servo for the first time.



CAUTION

- The lead of the built-in regenerative resistor is connected between P and C terminals on the servo amplifier power supply connectors (CNP1) of the MR-JN-20A(1)/40A. When taking the servo amplifier out from the shipping box, do not hold the lead of the built-in regenerative resistor.

Unpack the product and check the rating plate to see if the servo motor and servo amplifier are as you ordered.

(1) Servo amplifier

Packaged product	Quantity
Servo amplifier	1
Servo amplifier power supply connectors for CNP1 and CNP 2	1 each
MELSERVO-JN series Instructions and Cautions for Safe Use of AC Servos	1

(2) Servo motor

Packaged product	Quantity
Servo motor	1
Instructions and Cautions for Safe Use of AC Servos (Motor)	1

1. Operation and setting

Operation and settings of the servo amplifier are easily performed only on the display section (3-digit, 7-segment LED) and on the operation section (four pushbuttons and one-touch tuning button) located on the front panel of the servo amplifier.

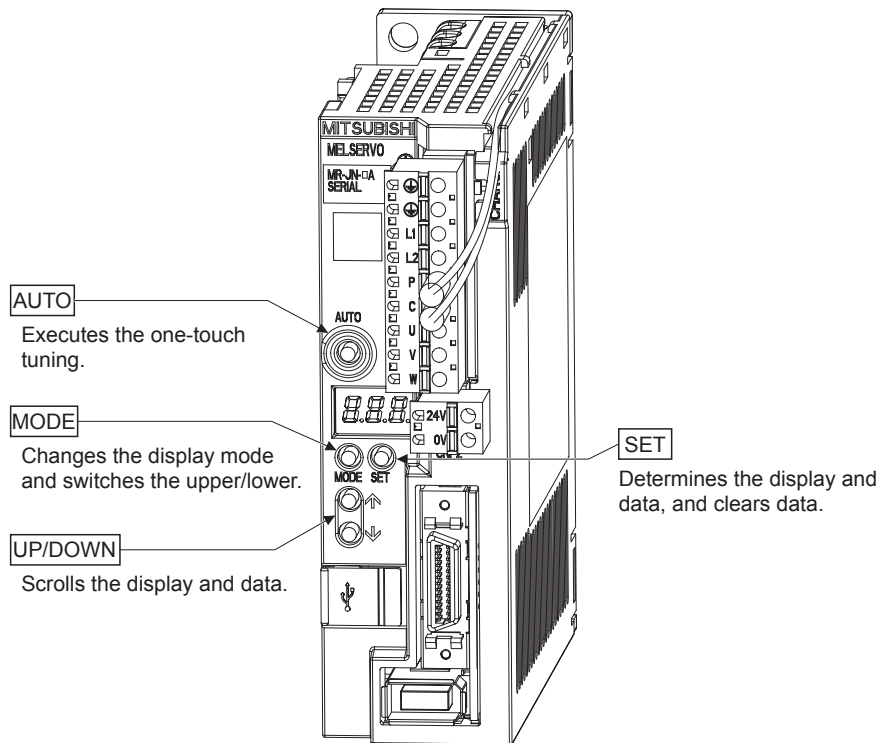

(1) One-touch tuning function (refer to section 6.1)

Gain and filter adjustment of the servo is easily made by the AUTO button located on the front panel of the servo amplifier.

(2) Status display, diagnosis, and parameter setting (refer to chapter 5)

The servo amplifier status display (cumulative feedback pulses, servo motor speed, and others), diagnosis (servo operation-ready complete status, external I/O signal ON/OFF, test operation), point table settings and parameter settings can be easily performed by the MODE, SET, UP and DOWN buttons located on the front panel of the servo amplifier.

2. Startup

When switching the power on for the first time, follow the startup procedure below.

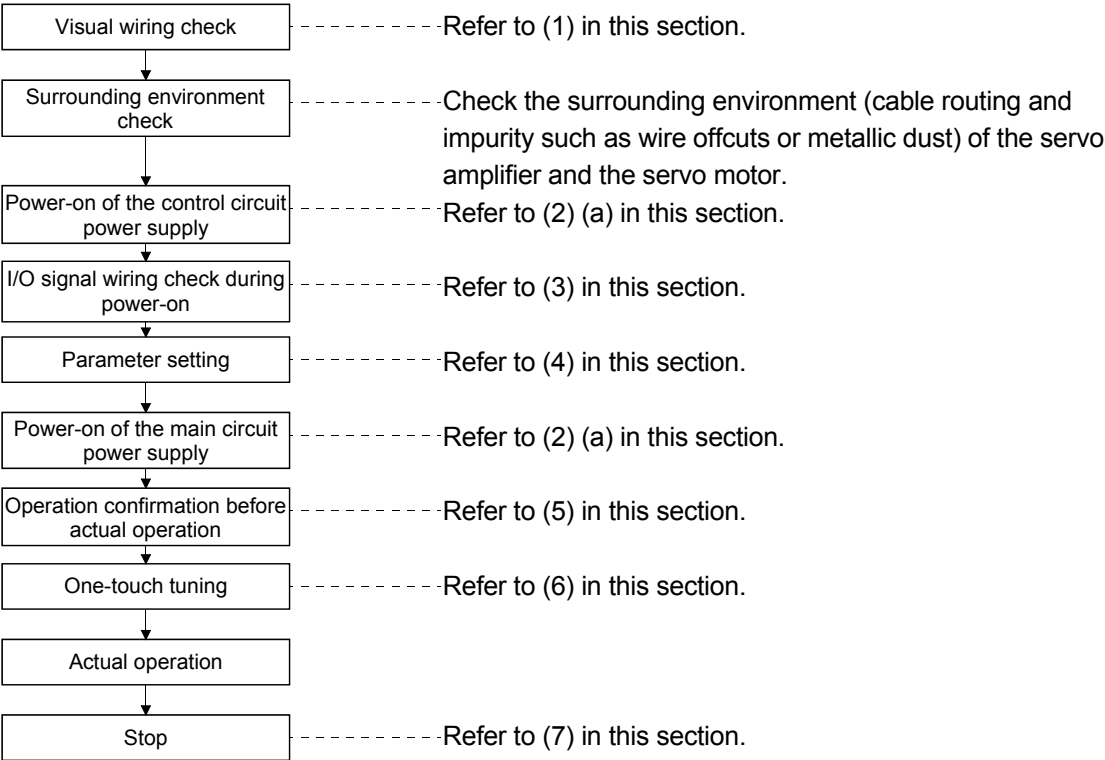

When switching the power off, follow (2) (b) in this section.

(1) Visual wiring check

Before switching on the main circuit and control circuit power supplies, check the following items.

Power supply system wiring

- The power supplied to the power input terminals (L1, L2, +24V, 0V) of the servo amplifier should satisfy the defined specifications. (Refer to section 1.3.)

Connection of servo amplifier and servo motor

- The servo motor power supply terminals (U, V, W) of the servo amplifier should match in phase with the power input terminals (U, V, W) of the servo motor.

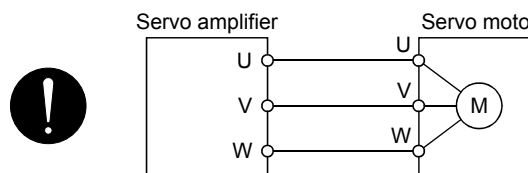

- The power supplied to the servo amplifier should not be connected to the servo motor power supply terminals (U, V, W). The connected servo amplifier and servo motor will be damaged.

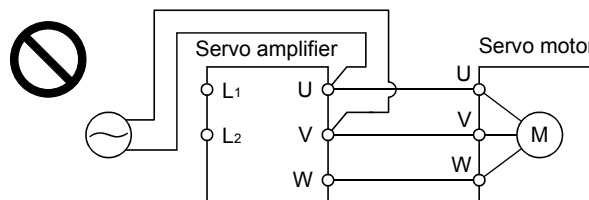

- The earth terminal of the servo motor should be connected to the PE terminal of the servo amplifier.

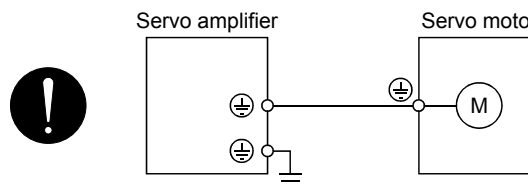

When regenerative option is used

- The built-in regenerative resistor and its wirings should be removed from the servo amplifier.
- The regenerative option should be connected to P and C terminals.
- A twisted cable should be used. (Refer to section 11.2 (4).)

I/O signal wiring

- The power supplied to CN1 connector (DICOM and DOCOM) of the servo amplifier should satisfy the defined specifications. (Refer to section 1.3.)
- SD and DOCOM of CN1 connector should not be shorted.

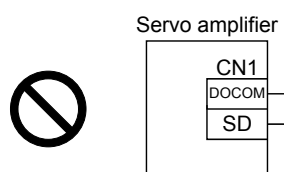

(2) Power on and off procedures

(a) Power-on

Switch the power on in the following procedure. Always follow this procedure at power-on.

- 1) Turn off the servo-on (SON).
- 2) Make sure that command and start signal from the controller are not input.
- 3) Switch on the control circuit power supply.

At power-on, "888" appears instantaneously, but it is not an error.

In the position control mode, data is displayed in 2[s] or later after displaying "CL" (cumulative feedback pulses in pulse unit) (initial value), or by pressing the "MODE", "UP" or "DOWN" button.



Displayed contents differ depending on each control mode. Refer to section 5.3 for details.

- 4) Switch on the main circuit power supply.

(b) Power-off

- 1) Make sure that command and start signal from the controller are not input.
- 2) Turn off the servo-on (SON).
- 3) Switch off the main circuit power supply.
- 4) Switch off the control circuit power supply.

(3) I/O signal wiring check during the energization

Input signal wiring confirmation

- On/off status of the input signals of CN1 connector can be checked using the external I/O signal display. By using this function, input signal wiring can be checked. (Refer to section 5.8.)

Output signal wiring confirmation

- Output signals of CN1 connector can be turned on/off forcibly using the DO output. By using this function, output signal wiring can be checked. (Refer to section 5.9.)

(4) Parameter setting

POINT
<ul style="list-style-type: none"> ▪ Some parameters are made valid when power is switched off, then on after setting. Refer to chapter 4 for details. ▪ For the positioning mode, refer to section 13.7.

Set the parameters as necessary, such as selecting the control mode and the regenerative option.

In the position control mode, the servo amplifier can be used just by changing the basic setting parameters (parameter No. PA □ □) mainly.

As necessary, set the gain/filter parameters (parameter No. PB □ □), the extension setting parameters (parameter No. PC □ □) and the I/O setting parameters (parameter No. PD □ □).

For the internal speed control mode and the internal torque control mode, refer to chapter 4.

The following shows the main parameters, which must be changed, among parameter No. PA□□.

PA01 Selection of control mode (refer to section 4.1.3)

Select the control mode of the servo amplifier, and whether to enable or not the one-touch tuning function.

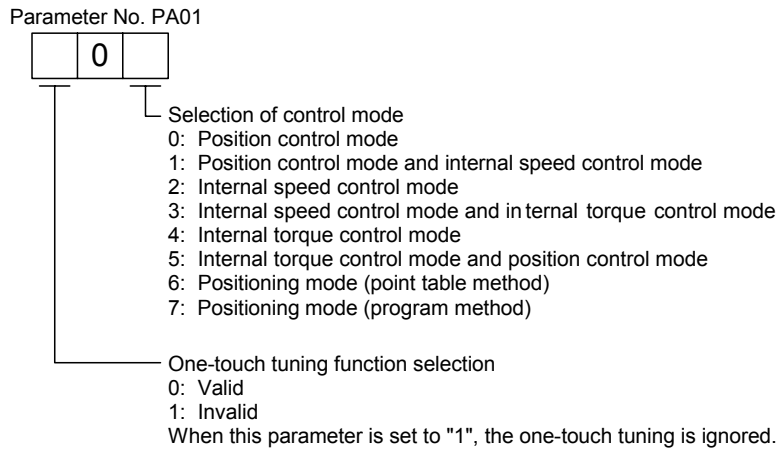

PA02 Selection of regenerative option (refer to section 4.1.4)

Set this parameter when using the regenerative option.

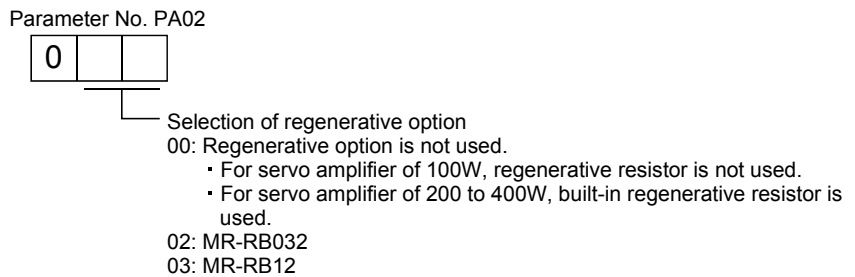

PA05 Number of command input pulses per servo motor revolution (refer to section 4.1.6)

Set the number of command input pulses necessary to rotate the servo motor one turn.

When "100 (10000[pulse/rev])" (initial value) is set to parameter No. PA05, the servo motor rotates one turn by inputting 1000 pulses of the command pulse to the servo amplifier. When "0" is set to parameter No. PA05, the servo motor rotates one turn by inputting the command pulse of servo motor resolution to the servo amplifier.

Parameter No. PA05 setting	Description
0	Servo motor resolution [pulse/rev]
100 to 500	Number of command input pulses necessary to rotate the servo motor one turn [$\times 100$ pulse/rev]

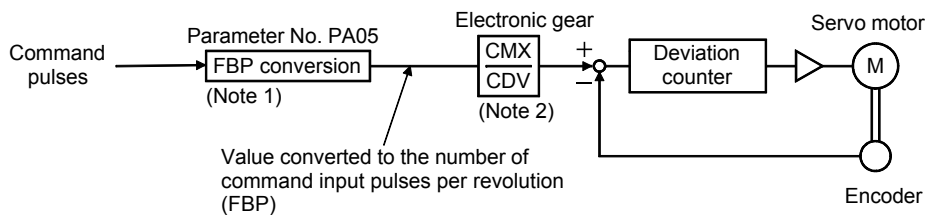

Note 1. This process converts the number of pulses required to rotate the servo motor one turn to the value set in parameter No. PA05.

Note 2. Electric gear numerator and denominator can be set by parameters No. PA06 and PA07. (Refer to section 4.1.7.)

PA13 Selection of command input pulse form (refer to section 4.1.11)

Select the input form of the pulse train input signal. Command pulses may be input in any of three different forms, for which positive or negative logic can be chosen.

Arrow \uparrow or \downarrow in the table indicates the timing of importing a pulse train. A- and B-phase pulse trains are imported after being multiplied by 4.

Parameter No. PA13

--	--	--

Selection of command input pulse form

Setting	Pulse train form	Forward rotation command	Reverse rotation command
00	Forward rotation pulse train Reverse rotation pulse train	PP \uparrow \uparrow \uparrow \uparrow \uparrow \uparrow	NP \uparrow \uparrow \uparrow \uparrow \uparrow \uparrow
		PP \uparrow \uparrow \uparrow \uparrow \uparrow \uparrow	NP \uparrow \uparrow \uparrow \uparrow \uparrow \uparrow
		PP \uparrow \uparrow \uparrow \uparrow \uparrow \uparrow	NP \uparrow \uparrow \uparrow \uparrow \uparrow \uparrow
01	Signed pulse train	PP \uparrow \uparrow \uparrow \uparrow \uparrow \uparrow	NP \uparrow \uparrow \uparrow \uparrow \uparrow \uparrow
		PP \uparrow \uparrow \uparrow \uparrow \uparrow \uparrow	NP \uparrow \uparrow \uparrow \uparrow \uparrow \uparrow
		PP \uparrow \uparrow \uparrow \uparrow \uparrow \uparrow	NP \uparrow \uparrow \uparrow \uparrow \uparrow \uparrow
02	A-phase pulse train B-phase pulse train	PP \uparrow \uparrow \uparrow \uparrow \uparrow \uparrow	NP \uparrow \uparrow \uparrow \uparrow \uparrow \uparrow
		PP \uparrow \uparrow \uparrow \uparrow \uparrow \uparrow	NP \uparrow \uparrow \uparrow \uparrow \uparrow \uparrow
		PP \uparrow \uparrow \uparrow \uparrow \uparrow \uparrow	NP \uparrow \uparrow \uparrow \uparrow \uparrow \uparrow
10	Forward rotation pulse train Reverse rotation pulse train	PP \downarrow \downarrow \downarrow \downarrow \downarrow \downarrow	NP \downarrow \downarrow \downarrow \downarrow \downarrow \downarrow
		PP \downarrow \downarrow \downarrow \downarrow \downarrow \downarrow	NP \downarrow \downarrow \downarrow \downarrow \downarrow \downarrow
		PP \downarrow \downarrow \downarrow \downarrow \downarrow \downarrow	NP \downarrow \downarrow \downarrow \downarrow \downarrow \downarrow
11	Signed pulse train	PP \downarrow \downarrow \downarrow \downarrow \downarrow \downarrow	NP \downarrow \downarrow \downarrow \downarrow \downarrow \downarrow
		PP \downarrow \downarrow \downarrow \downarrow \downarrow \downarrow	NP \downarrow \downarrow \downarrow \downarrow \downarrow \downarrow
		PP \downarrow \downarrow \downarrow \downarrow \downarrow \downarrow	NP \downarrow \downarrow \downarrow \downarrow \downarrow \downarrow
12	A-phase pulse train B-phase pulse train	PP \downarrow \downarrow \downarrow \downarrow \downarrow \downarrow	NP \downarrow \downarrow \downarrow \downarrow \downarrow \downarrow
		PP \downarrow \downarrow \downarrow \downarrow \downarrow \downarrow	NP \downarrow \downarrow \downarrow \downarrow \downarrow \downarrow
		PP \downarrow \downarrow \downarrow \downarrow \downarrow \downarrow	NP \downarrow \downarrow \downarrow \downarrow \downarrow \downarrow

Pulse train input filter selection

Setting	Command pulse frequency
0	1Mpps or less
1	500kpps or less
2	200kpps or less

POINT	<ul style="list-style-type: none"> The noise immunity can be enhanced by setting parameter No. PA13 to "1 □ □" when the command pulse frequency is 500kpps or less or "2 □ □" when 200kpps or less.
--------------	--

PA14 Selection of servo motor rotation direction (refer to section 4.1.12)

Select servo motor rotation direction relative to the input pulse train.

Parameter No. PA14 setting	Servo motor rotation direction	
	When forward rotation pulse is input	When reverse rotation pulse is input
0	CCW	CW
1	CW	CCW

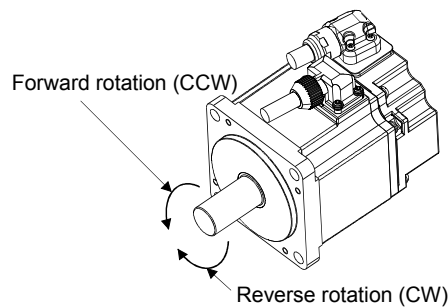

(5) Operation confirmation before actual operation

Before starting actual operation, perform JOG operation to make sure that the machine operates properly. MR-JN can perform the JOG operation in the test operation mode on the operation section (four pushbuttons). (Refer to section 5.10.)

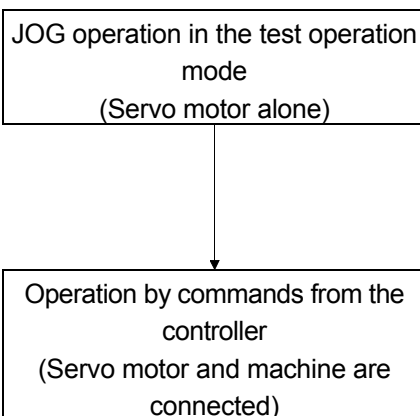

(a) Confirm that the servo amplifier and servo motor operate properly. With the servo motor disconnected from the machine, use the test operation mode (JOG operation) at the slowest speed and check whether the servo motor rotates correctly.

(b) Confirm that the servo motor rotates correctly at the slowest speed under the commands from the controller. Make sure that the servo motor rotates in the following procedure.

- 1) Switch on the forced stop (EM1) and servo-on (SON). When the servo amplifier is in a servo-on status, the ready (RD) switches on.
- 2) Switch on the forward rotation stroke end (LSP) and the reverse rotation stroke end (LSN).
- 3) In the position control mode, when command pulses are input from the controller, the servo motor starts rotating. Give a low speed command at first and check the operation direction, etc. of the servo motor. If the servo motor does not rotate in the intended direction, check the input signal.
- 4) After checking that the machine operates properly, perform the automatic operation by the program of the controller to check for any problem with the operation.

(6) One-touch tuning

Just by pressing the "AUTO" button on the front panel of the servo amplifier during operation, the gain/filter is easily adjusted.

(Refer to section 6.1.)

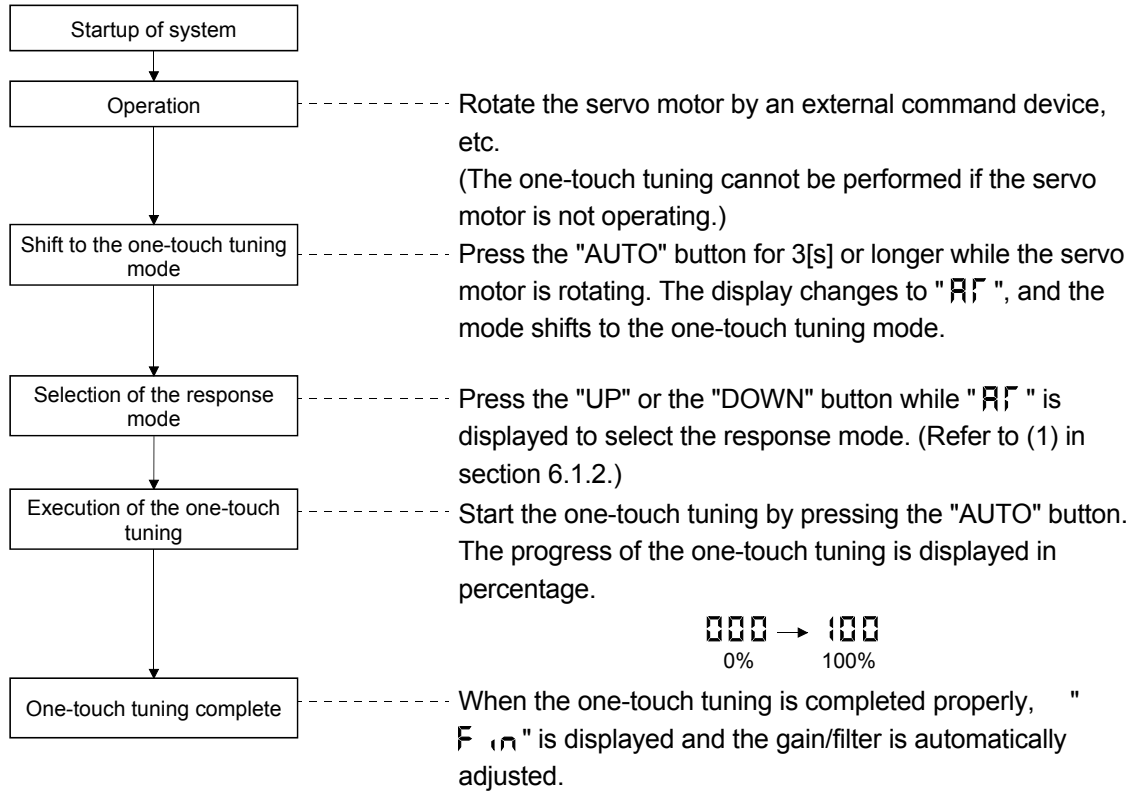

POINT

- For the fine adjustment after the one-touch tuning, refer to section 6.4.

(7) Stop

In any of the following statuses, the servo amplifier interrupts and stops the operation of the servo motor. Refer to section 3.11 for the servo motor with an electromagnetic brake.

(a) Servo-on (SON) OFF

The base circuit is shut off and the servo motor coasts.

(b) Alarm occurrence

When an alarm occurs, the base circuit is shut off and the dynamic brake activates to stop the servo motor immediately.

(c) Forced stop (EM1) OFF

The base circuit is shut off and the dynamic brake activates to stop the servo motor immediately. Servo forced stop warning alarm (E6.1) occurs.

(d) Forward rotation stroke end (LSP) or reverse rotation stroke end (LSN) OFF

Position control mode: Droop pluses are cleared, and the servo motor shaft is locked. The servo motor can rotate in an opposite direction.

Internal speed control mode: The servo motor stops immediately, and the shaft is locked. The servo motor can rotate in an opposite direction.

(e) Simultaneous ON or simultaneous OFF of forward rotation start (ST1) and reverse rotation start (ST2)

In internal speed control mode: The servo motor decelerates to a stop.

In positioning mode: The servo motor decelerates to a stop after JOG operation.

(f) Simultaneous ON or simultaneous OFF of forward rotation selection (RS1) and reverse rotation selection (RS2) (only in the internal torque control)

The servo motor coasts.

POINT
<ul style="list-style-type: none"> ▪ The forward rotation stroke end (LSP) and reverse rotation stroke end (LSN) operate as follows. ▪ Assigned to the external input signals: depends on the value set in parameter No. PD01. ▪ Not assigned to the external input signals: automatically turns on regardless of the value set in parameter No. PD01. ▪ In the internal torque control mode, the forward rotation stroke end (LSP) and reverse rotation stroke end (LSN) become invalid. (Refer to section 3.5.)

3. Troubleshooting at startup

**CAUTION**

- Never adjust or change the parameter values extremely as it will make operation instable.

POINT

- You can refer to reasons for servo motor rotation failure, etc. using MR Configurator.

The following faults may occur at startup. If any of such faults occurs, take the corresponding action.

(1) Troubleshooting

No.	Step of occurrence	Fault	Investigation	Possible cause	Reference
1	Power on	<ul style="list-style-type: none"> The 3-digit, 7-segment LED is not lit. The 3-digit, 7-segment LED flickers. 	Not improved even if CN1, CN2 and CN3 connectors are disconnected.	1. Power supply voltage fault 2. Servo amplifier is faulty.	/
			Improved when CN1 connector is disconnected.	Power supply of CN1 cabling is shorted.	
			Improved when CN2 connector is disconnected.	1. Power supply of encoder cabling is shorted. 2. Encoder is faulty.	
			Improved when CN3 connector is disconnected.	Power supply of CN3 cabling is shorted.	
		Alarm occurs.	Remove cause.		Section 8.2
		Digital output ALM occurs. The 3-digit, 7-segment LED does not display the alarm.	Check the ON/OFF status of the output signal on the external I/O signal display (refer to section 5.8).	Wiring mistake. The polarity of the digital output circuit diode is not correct.	Section 3.8.2
2	Switch on servo-on (SON).	Alarm occurs.	Remove cause.		Section 8.2
		Servo motor shaft is free.	Check the followings. 1. Check the display to see if the servo amplifier is ready to operate. 2. Check the external I/O signal display (refer to section 5.8) to see if the servo-on (SON) is ON.	1. Servo-on (SON) is not input. (Wiring mistake) 2. External 24VDC power is not supplied to DICOM.	Section 5.8
3	Input command pulse. (Test operation) (In the position control mode)	Servo motor does not rotate.	Check the cumulative command pulses on the status display or on MR Configurator.	1. Wiring mistake. (a) For open collector pulse train input, 24VDC power is not supplied to OPC. (b) LSP and LSN are not on. (c) Wiring mistake. The polarity of the digital output circuit diode is not correct. 2. No pulses are input. 3. Electromagnetic brake operates.	Section 3.8.2
			Check if the ready (RD) is ON.		Section 3.11
			Check the set value of parameter No.PA13 (command input pulse form).		Section 4.1.11
			Check if the electromagnetic brake interlock (MBR) is ON.		Section 5.3
			Check the ON/OFF status of the output signal on the external I/O signal display (refer to section 5.8).		Section 3.8.2

Introduction

No	Step of occurrence	Fault	Investigation	Possible cause	Reference
3	Input command pulse. (Test operation) (In the position control mode)	Servo motor rotates in reverse direction.	Check the cumulative command pulses on the status display or on MR Configurator.	1. Mistake in wiring to controller. 2. Mistake in setting of parameter No. PA14.	Section 4.1.12 Section 5.3
			Check the set value of parameter No.PA14 (rotation direction selection).		
4	Switch on forward rotation start (ST1) or reverse rotation start (ST2). (In the internal speed control mode)	Servo motor does not rotate.	Check the ON/OFF status of the input signal on the external I/O signal display (refer to section 5.8).	LSP, LSN, ST1 or ST2 is off.	Section 5.8
			Check the internal speed commands 0 to 7 (parameters No. PC05 to PC08 and PC31 to PC34).	Set value is 0.	Section 4.3.2
			Check the forward torque limit (parameter No. PA11) or reverse torque limit (parameter No. PA12).	Torque limit level is too low as compared to the load torque.	Section 4.1.10
5	Switch on forward rotation selection (RS1) or reverse rotation selection (RS2). (In the internal torque control mode)	Servo motor does not rotate.	Check the set value of parameter No.PC12 (internal torque command).	Internal torque command is too low as compared to the load torque.	Section 4.3.2
			Check the ON/OFF status of the input signal on the external I/O signal display (refer to section 5.8).	RS1 or RS2 is off.	Section 5.8
			Check the internal speed limits 0 to 7 (parameters No. PC05 to PC08 and PC31 to PC34).	Set value is 0.	Section 4.3.2
			Check the forward torque limit (parameter No. PA11) or reverse torque limit (parameter No. PA12).	Set value is 0.	Section 4.1.10
6	Switch on forward rotation start (ST1) or reverse rotation start (ST2). (In the positioning mode)	Servo motor does not rotate.	Check the ON/OFF status of the input signal on the external I/O signal display (refer to section 5.8).	LSP, LSN, ST1 or ST2 is off.	Section 5.8
			Check the values of position data and servo motor speed set in the point table or program.	Set value is 0.	Chapter 13
			Check the forward torque limit (parameter No. PA11) or reverse torque limit (parameter No. PA12).	Torque limit level is too low as compared to the load torque.	Section 4.1.10
7	Gain adjustment (In the position control mode) (In the internal speed control mode) (In the positioning mode)	Rotation ripples (speed fluctuations) are large at low speed.	Make gain adjustment in the following procedure. 1. Increase the auto tuning response level. 2. Repeat acceleration and deceleration several times to complete auto tuning.	Gain adjustment fault	Chapter 6
		Large load inertia moment causes the servo motor shaft to oscillate side to side.	If the servo motor may be run with safety, repeat acceleration and deceleration several times to complete auto tuning.	Gain adjustment fault	Chapter 6
8	Cyclic operation (In the position control mode)	Position shift occurs.	Confirm the cumulative command pulses, the cumulative feedback pulses and the actual servo motor position.	Pulse counting error, etc. due to noise.	(2) in this section

(2) How to find the cause of position shift

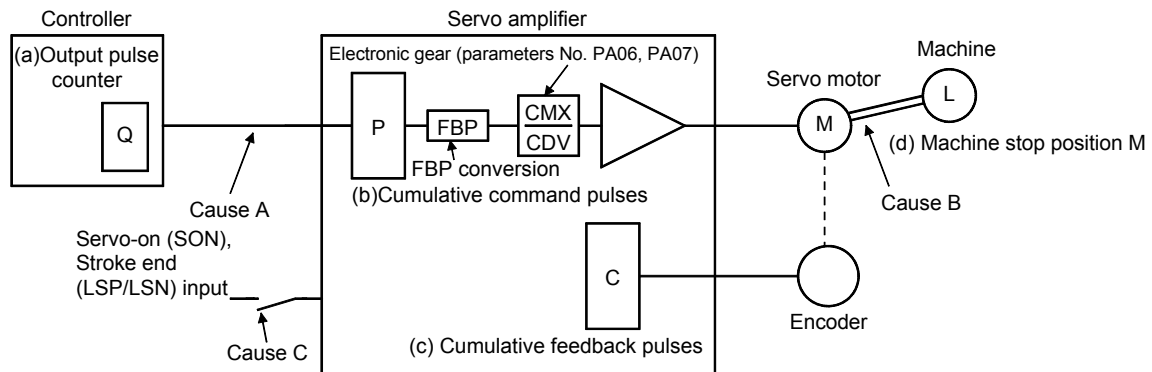

When a position shift occurs, check (a) output pulse counter Q, (b) cumulative command pulses P, (c) cumulative feedback pulses C, and (d) machine stop position M in the above diagram.

Cause A, Cause B and Cause C indicate position shift causes. For example, Cause A indicates that noise entered the wiring between the controller and servo amplifier, causing the command input pulse to be miss-counted.

In a normal status without position shift, there are the following relationships.

- 1) $Q = P$ (output pulse counter = cumulative command pulses)
- 2) When using the electronic gear

$$P \cdot \frac{\text{CMX (parameter No. PA06)}}{\text{CDV (parameter No. PA07)}} \cdot \frac{\text{Servo motor encoder resolution}}{\text{FBP (parameter No. PA05) (Note)}}$$

$$= C \text{ (cumulative command pulses} \times \text{electronic gear} = \text{cumulative feedback pulses)}$$

Note. When "0" is set to the FBP (parameter No. PA05), the FBP becomes the servo motor encoder resolution.

- 3) $C \cdot \Delta l = M$ (cumulative feedback pulses \times travel per pulse = machine position)

Check for a position shift in the following sequence.

- 1) When $Q \neq P$

Noise entered in the pulse train signal wiring between the controller and servo amplifier, causing command input pulses to be miss-counted. (Cause A)

Make the following check or take the following measures.

 - Check the shielding.
 - Run wiring away from the power circuit.
 - Install a data line filter. (Refer to section 11.9 (2) (a).)

POINT

- The noise immunity can be enhanced by setting parameter No. PA13 to "1 □ □" when the command pulse frequency is 500kpps or less or "2 □ □" when 200kpps or less.

2) When $P \cdot \frac{CMX}{CDV} \cdot \frac{\text{Servo motor encoder resolution}}{\text{FBP (parameter No. PA05) (Note)}} \neq C$

Note. When "0" is set to the FBP (parameter No. PA05), the FBP becomes the servo motor encoder resolution.

During the operation, the servo-on (SON), the forward/reverse rotation stroke end (LSP/LSN) was turned off, or the clear (CR) or the reset (RES) was turned on. (Cause C)

If a malfunction may occur due to much noise, increase the input filter setting (parameter No. PD19).

3) When $C \cdot \Delta l \neq M$

Mechanical slip occurred between the servo motor and machine. (Cause B)

4. Tough drive function

⚠ CAUTION • Since the operation status of devices may be changed by the tough drive operation, check for any problems before making this function valid.

POINT

- For details of the tough drive function, refer to section 7.1.

The tough drive function continues the operation not to stop a machine in such situations when normally an alarm is activated.

Three types of tough drive function can be selected in parameter No. PA04.

Parameter No. PA04

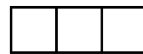

Overload tough drive function selection
Set the tough drive function for overload.

Setting	Overload tough drive function
0	Invalid
1	Valid

Vibration tough drive function selection
Set the function for vibration suppression.

Setting	Vibration tough drive function
0	Invalid
1	Valid

Instantaneous power failure tough drive function selection
Set tough drive function for instantaneous power failure of the main circuit power supply.

Setting	Instantaneous power failure tough drive function
0	Invalid
1	Valid

(1) Overload tough drive function

This function reduces the effective load ratio before an overload alarm occurs to avoid the alarm.

(2) Vibration tough drive function

This function suppresses the machine resonance caused by aging distortion or individual difference of the machine.

(3) Instantaneous power failure tough drive function

This function avoids the instantaneous power failure during operation.

CONTENTS

1. FUNCTIONS AND CONFIGURATION	1 - 1 to 1 -12
1.1 Introduction	1 - 1
1.2 Function block diagram	1 - 3
1.3 Servo amplifier standard specifications	1 - 6
1.4 Function list	1 - 8
1.5 Model code definition	1 -10
1.6 Combination with servo motor	1 -10
1.7 Parts identification	1 -11
1.8 Configuration including auxiliary equipment.....	1 -12
2. INSTALLATION	2 - 1 to 2 - 6
2.1 Installation direction and clearances	2 - 2
2.2 Keep out foreign materials	2 - 3
2.3 Cable stress.....	2 - 4
2.4 Inspection items	2 - 4
2.5 Parts having service lives.....	2 - 5
3. SIGNALS AND WIRING	3 - 1 to 3 -48
3.1 Input power supply circuit	3 - 2
3.2 I/O signal connection example.....	3 - 4
3.2.1 Position control mode	3 - 4
3.2.2 Internal speed control mode	3 - 6
3.2.3 Internal torque control mode	3 - 7
3.3 Explanation of power supply system	3 - 8
3.3.1 Signal explanations	3 - 8
3.3.2 Power-on sequence	3 - 8
3.3.3 CNP1 and CNP2 wiring method	3 -10
3.4 Connectors and signal arrangements	3 -13
3.5 Signal explanations	3 -16
3.6 Detailed description of the signals	3 -22
3.6.1 Position control mode.....	3 -22
3.6.2 Internal speed control mode	3 -25
3.6.3 Internal torque control mode	3 -28
3.6.4 Position/speed control change mode	3 -31
3.6.5 Internal speed/internal torque control change mode.....	3 -32
3.6.6 Internal torque/position control change mode	3 -33
3.7 Alarm occurrence timing chart.....	3 -34
3.8 Interfaces	3 -35
3.8.1 Internal connection diagram.....	3 -35
3.8.2 Detailed description of interfaces.....	3 -36
3.8.3 Source I/O interfaces	3 -39
3.9 Treatment of cable shield external conductor	3 -40
3.10 Connection of servo amplifier and servo motor	3 -41
3.10.1 Connection instructions.....	3 -41

3.10.2 Power supply cable wiring diagrams	3 - 42
3.11 Servo motor with an electromagnetic brake.....	3 - 43
3.11.1 Safety precautions.....	3 - 43
3.11.2 Setting.....	3 - 43
3.11.3 Timing charts.....	3 - 44
3.11.4 Wiring diagrams (HF-KN series • HF-KP □ G1/G5/G7 series servo motor).....	3 - 46
3.12 Grounding.....	3 - 48

4. PARAMETERS	4 - 1 to 4 - 54
----------------------	------------------------

4.1 Basic setting parameters (No. PA □ □)	4 - 2
4.1.1 Parameter list	4 - 2
4.1.2 Parameter write inhibit	4 - 3
4.1.3 Selection of control mode.....	4 - 4
4.1.4 Selection of regenerative option	4 - 4
4.1.5 Selection of the tough drive function.....	4 - 5
4.1.6 Number of command input pulses per servo motor revolution.....	4 - 6
4.1.7 Electronic gear.....	4 - 7
4.1.8 Auto tuning.....	4 - 11
4.1.9 In-position range.....	4 - 12
4.1.10 Torque limit.....	4 - 13
4.1.11 Selection of command input pulse form	4 - 14
4.1.12 Selection of servo motor rotation direction	4 - 15
4.1.13 Encoder output pulses	4 - 16
4.2 Gain/filter parameters (No. PB □ □)	4 - 19
4.2.1 Parameter list	4 - 19
4.2.2 Detail list	4 - 21
4.2.3 Position smoothing.....	4 - 29
4.3 Extension setting parameters (No. PC □ □).....	4 - 30
4.3.1 Parameter list	4 - 30
4.3.2 List of details.....	4 - 32
4.3.3 Alarm history clear.....	4 - 39
4.3.4 Drive recorder function.....	4 - 40
4.4 I/O setting parameters (No. PD □ □)	4 - 44
4.4.1 Parameter list	4 - 44
4.4.2 List of details.....	4 - 45
4.4.3 Using forward/reverse rotation stroke end to change the stopping pattern	4 - 54

5. DISPLAY AND OPERATION SECTIONS	5 - 1 to 5 - 30
--	------------------------

5.1 Overview.....	5 - 1
5.2 Display sequence.....	5 - 2
5.3 Status display	5 - 3
5.3.1 Display transition	5 - 4
5.3.2 Display examples	5 - 5
5.3.3 Status display list.....	5 - 7
5.4 Diagnostic mode.....	5 - 9
5.5 Alarm mode	5 - 11
5.6 Point table mode	5 - 13
5.6.1 Point table transition.....	5 - 13

5.6.2 Point table mode setting screen sequence	5 -14
5.6.3 Operation example	5 -15
5.7 Parameter mode	5 -17
5.7.1 Parameter mode transition	5 -17
5.7.2 Operation example	5 -18
5.8 External I/O signal display	5 -20
5.9 Output signal (DO) forced output	5 -23
5.10 Test operation mode	5 -24
5.10. 1 Mode change	5 -24
5.10. 2 JOG operation	5 -25
5.10. 3 Positioning operation	5 -26
5.10. 4 Motor-less operation	5 -28
5.10. 5 Forced tough drive operation	5 -29
5.11 One-touch tuning	5 -29

6. GENERAL GAIN ADJUSTMENT	6 - 1 to 6 -18
-----------------------------------	-----------------------

6.1 One-touch tuning	6 - 1
6.1.1 One-touch tuning procedure	6 - 2
6.1.2 Display transition and operation procedure of the one-touch tuning	6 - 3
6.1.3 Precautions for one-touch tuning	6 - 7
6.2 Gain adjustment methods	6 - 8
6.3 Auto tuning mode 1	6 -10
6.3.1 Overview	6 -10
6.3.2 Auto tuning mode 1 basis	6 -11
6.3.3 Adjustment procedure by auto tuning	6 -12
6.3.4 Response level setting in auto tuning mode 1	6 -13
6.4 2-gain adjustment mode	6 -14
6.5 Manual mode	6 -15

7. SPECIAL ADJUSTMENT FUNCTIONS	7 - 1 to 7 -18
--	-----------------------

7.1 Tough drive function	7 - 1
7.1.1 Overload tough drive function	7 - 1
7.1.2 Vibration tough drive function	7 - 2
7.1.3 Instantaneous power failure tough drive function	7 - 4
7.2 Machine resonance suppression function	7 - 6
7.2.1 Function block diagram	7 - 6
7.2.2 Adaptive filter II	7 - 6
7.2.3 Machine resonance suppression filter	7 - 8
7.2.4 Advanced vibration suppression control	7 - 9
7.2.5 Low-pass filter	7 -13
7.3 Gain changing function	7 -13
7.3.1 Applications	7 -13
7.3.2 Function block diagram	7 -14
7.3.3 Parameters	7 -15
7.3.4 Gain changing procedure	7 -17

8. TROUBLESHOOTING	8 - 1 to 8 -30
8.1 Alarms and warning list.....	8 - 1
8.2 Remedies for alarms.....	8 - 3
8.3 Remedies for warnings.....	8 -24
9. OUTLINE DRAWINGS	9 - 1 to 9 - 4
9.1 Servo amplifier.....	9 - 1
9.2 Connector.....	9 - 3
10. CHARACTERISTICS	10- 1 to 10- 6
10.1 Overload protection characteristics.....	10- 1
10.2 Power supply capacity and generated loss.....	10- 2
10.3 Dynamic brake characteristics.....	10- 4
10.3.1 Dynamic brake operation.....	10- 4
10.3.2 The dynamic brake at the load inertia moment.....	10- 5
10.4 Cable flexing life.....	10- 6
10.5 Inrush currents at power-on of main circuit and control circuit.....	10- 6
11. OPTIONS AND AUXILIARY EQUIPMENT	11- 1 to 11-46
11.1 Cable/connector sets.....	11- 1
11.1.1 Combinations of cable/connector sets.....	11- 2
11.1.2 Encoder cable/connector sets.....	11- 7
11.1.3 Motor power supply cables.....	11-17
11.1.4 Motor brake cables.....	11-19
11.2 Regenerative options.....	11-21
11.3 Junction terminal block MR-TB26A.....	11-25
11.4 MR Configurator.....	11-27
11.5 Selection example of wires.....	11-29
11.6 No-fuse breakers, fuses, magnetic contactors.....	11-32
11.7 Power factor improving AC reactor FR-HAL.....	11-33
11.8 Relays (recommended).....	11-33
11.9 Noise reduction techniques.....	11-34
11.10 Leakage current breaker.....	11-40
11.11 Circuit protector.....	11-42
11.12 EMC filter (recommended).....	11-42
11.13 Surge protector (recommended).....	11-43
11.14 MR-HDP01 manual pulse generator.....	11-45
12. SERVO MOTOR	12- 1 to 12-38
12.1 Introduction.....	12- 1
12.1.1 Rating plate.....	12- 1
12.1.2 Parts identification.....	12- 1
12.1.3 Electromagnetic brake.....	12- 2
12.1.4 Servo motor shaft shapes.....	12- 4

12.2 Installation	12- 5
12.2.1 Installation direction.....	12- 6
12.2.2 Precautions for load remove.....	12- 7
12.2.3 Permissible load for the shaft.....	12- 8
12.2.4 Protection from oil and water	12- 8
12.2.5 Cable	12- 9
12.2.6 Inspection	12- 9
12.2.7 Life	12-10
12.2.8 Machine accuracies	12-10
12.3 Connectors used for servo motor wiring	12-11
12.3.1 Selection of connectors.....	12-11
12.3.2 Wiring connectors (Connector configurations A B C)	12-12
12.4 Connector outline drawings	12-13
12.5 HF-KN series servo motor	12-15
12.5.1 Model definition	12-15
12.5.2 Standard specifications.....	12-16
12.5.3 Electromagnetic brake characteristics.....	12-18
12.5.4 Servo motors with special shafts	12-19
12.5.5 Connector installation.....	12-20
12.5.6 Outline drawings.....	12-21
12.6 HF-KP series servo motor	12-27
12.6.1 Model definition	12-27
12.6.2 Specifications	12-28
12.6.3 Electromagnetic brake characteristics.....	12-30
12.6.4 Servo motor with a reduction gear.....	12-31
12.6.5 Connector installation.....	12-36

13. POSITIONING MODE	13- 1 to 13-94
-----------------------------	-----------------------

13.1 Selection method of each operation mode.....	13- 1
13.2 Signals	13- 2
13.2.1 I/O signal connection example.....	13- 2
13.2.2 Connectors and signal arrangements	13- 3
13.2.3 Signal explanations	13- 4
13.2.4 Detailed description of the signals	13-11
13.3 Automatic operation mode for point table method	13-15
13.3.1 What is automatic operation mode?	13-15
13.3.2 Automatic operation using point table	13-17
13.4 Automatic operation mode for program method	13-28
13.4.1 What is automatic operation mode for program method?	13-28
13.4.2 Programming language.....	13-29
13.4.3 Basic setting of signals and parameters.....	13-44
13.4.4 Program operation timing chart	13-45
13.5 Manual operation mode	13-46
13.5.1 JOG operation	13-46
13.5.2 Manual pulse generator operation.....	13-47
13.6 Home position return mode	13-49
13.6.1 Outline of home position return.....	13-49
13.6.2 Selection of home position return mode.....	13-50

13.6.3 Dog type home position return.....	13-51
13.6.4 Count type home position return.....	13-54
13.6.5 Data set type home position return.....	13-56
13.6.6 Stopper type home position return	13-57
13.6.7 Home position ignorance (Servo-on position as home position)	13-59
13.6.8 Dog type rear end reference home position return	13-60
13.6.9 Count type front end reference home position return	13-62
13.6.10 Dog cradle type home position return	13-64
13.6.11 Home position return automatic return function	13-66
13.7 Parameters	13-67
13.7.1 Basic setting parameters (No. PA□□)	13-68
13.7.2 Gain/filter parameters (No. PB□□)	13-73
13.7.3 Extension setting parameters (No. PC□□)	13-75
13.7.4 I/O setting parameters (No. PD□□)	13-78
13.7.5 Positioning setting parameters (No. PE□□)	13-80
13.8 Point table setting method	13-86
13.9 Program setting method.....	13-88
13.10 Single-step feed usage in the test operation mode	13-91

APPENDIX	App.- 1 to App.-14
----------	--------------------

App. 1 Parameter list.....	App.- 1
App. 2 Servo motor ID codes.....	App.- 6
App. 3 Signal layout recording paper.....	App.- 6
App. 4 Status display block diagram.....	App.- 7
App. 5 Compliance with EC directives.....	App.- 9
App. 6 Conformance with UL/CSA standard.....	App.-12

1. FUNCTIONS AND CONFIGURATION

1. FUNCTIONS AND CONFIGURATION

1.1 Introduction

The Mitsubishi MELSERVO-JN series general-purpose AC servo is based on the MELSERVO-J3 series, and retains its high performance, with some limitations in functions.

It has position control, internal speed control, internal torque control and positioning modes. Further, it can perform operation with the control modes changed, e.g. position/internal speed control, internal speed/internal torque control and internal torque/position control. Hence, it is applicable to a wide range of fields, not only precision positioning and smooth speed control of machine tools and general industrial machines but also line control and tension control.

As this new series has the USB serial communication function, a MR Configurator installed personal computer or the like can be used to perform parameter setting, test operation, status display monitoring, gain adjustment, etc.

With one-touch tuning and real-time auto tuning, you can easily and automatically adjust the servo gains according to the machine.

The servo amplifier has the tough drive function that continues the operation not to stop a machine in such situation when normally an alarm is activated.

The MELSERVO-JN series servo motor is equipped with an incremental encoder which has the resolution of 131072 pulses/rev to ensure the positioning with a high accuracy.

(1) Position control mode

Up to 1Mpps high-speed pulse train is used to control the speed and the direction of a servo motor and execute precision positioning of 131072 pulses/rev resolution.

The position smoothing function provides a choice of two different modes appropriate for a machine, so a smoother start/stop can be made in response to a sudden position command.

A torque limit is imposed on the servo amplifier by the clamp circuit to protect the power transistor in the main circuit from overcurrent due to sudden acceleration/deceleration or overload. This torque limit value can be changed to any value with the parameter.

(2) Internal speed control mode

A parameter-driven internal speed command (max. 8 speeds) is used to control the speed and the direction of a servo motor precisely and smoothly.

There are also the acceleration/deceleration time constant setting in response to the speed command and the servo lock function at a stop time.

(3) Internal torque control mode

An internal torque command (0.0% to 100.0%) is used to control the torque output by the servo motor. To prevent unexpected operation under no load, the speed limit function (internal setting) is also available for application to tension control, etc.

1. FUNCTIONS AND CONFIGURATION

(4) Positioning mode

The positioning mode has point table method and program method.

(a) Point table method

The positioning operation can be executed by setting the position data (the target position), the servo motor speed, the acceleration/deceleration time constant, etc. in the point table as if setting them in parameters. This is the most appropriate to configure a simple positioning system or to simplify a system.

7 point tables can be used.

(b) Program method

The positioning operation is performed by creating the positioning data (the target position), the servo motor speed, the acceleration/deceleration time constant, etc. as a program and by executing the program. This is the most appropriate to configure a simple positioning system or to simplify a system.

Up to 8 programs can be created. The program capacity is 120 steps as a total of all programs.

1. FUNCTIONS AND CONFIGURATION

1.2 Function block diagram

The function block diagram of this servo motor is shown below.

(1) Position control mode, internal speed control mode, internal torque control mode

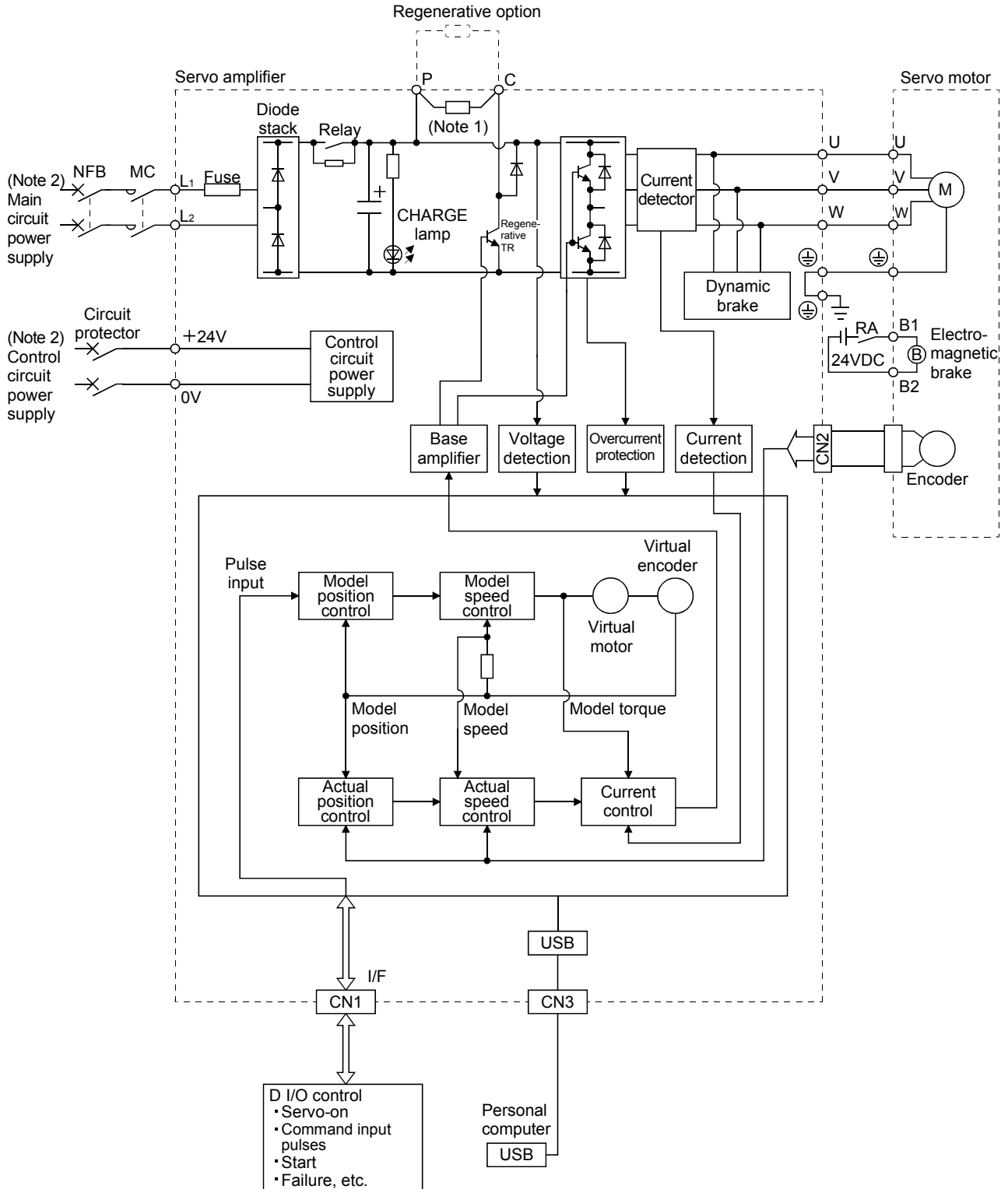

Note 1. A built-in regenerative resistor is not provided for the MR-JN-10A(1).

2. For the specification of power supply, refer to section 1.3.

1. FUNCTIONS AND CONFIGURATION

(2) Positioning mode (Point table method)

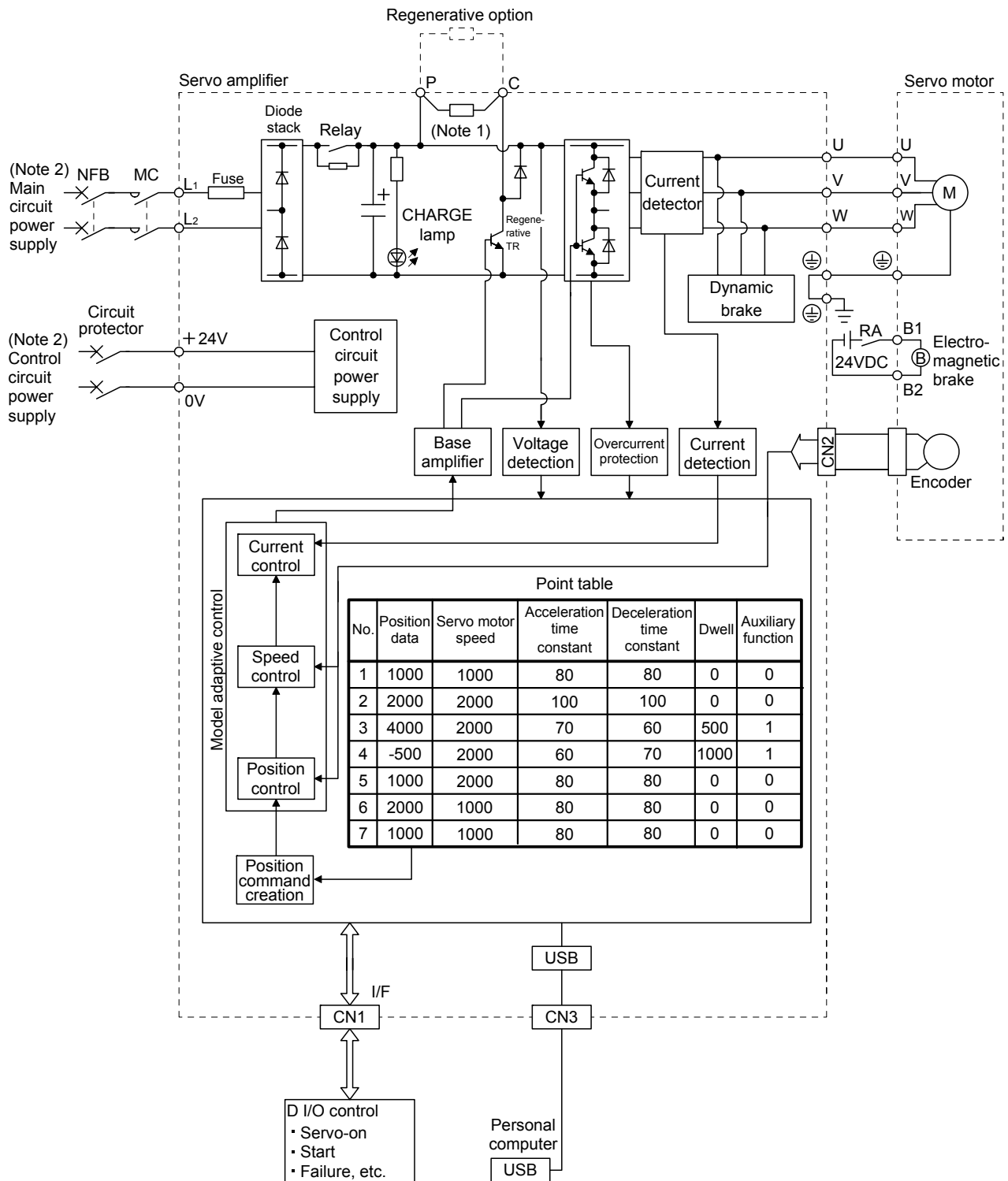

Note 1. A built-in regenerative resistor is not provided for the MR-JN-10A(1).

2. For the specification of power supply, refer to section 1.3.

1. FUNCTIONS AND CONFIGURATION

(3) Positioning mode (Program method)

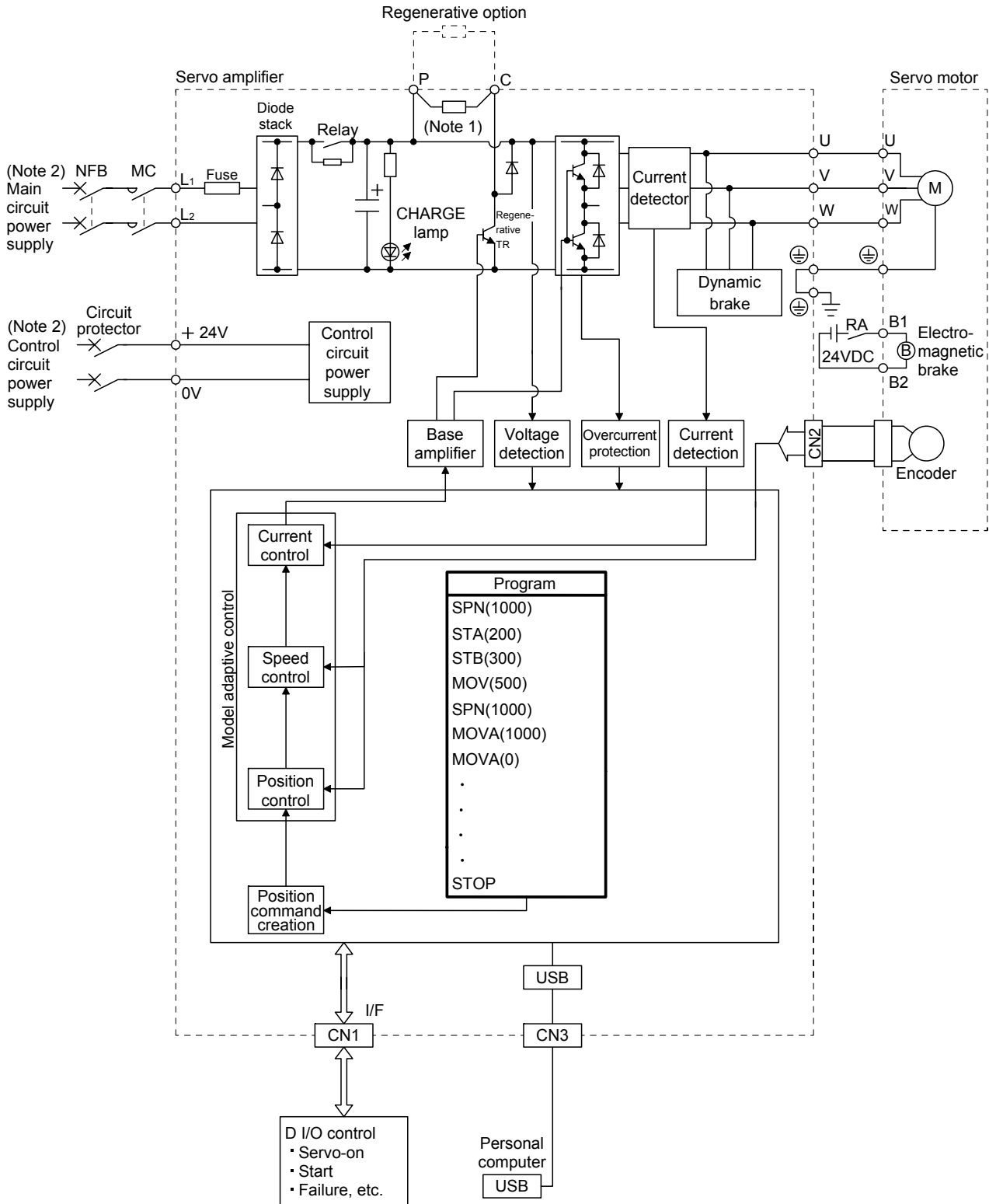

Note 1. A built-in regenerative resistor is not provided for the MR-JN-10A(1).

2. For the specification of power supply, refer to section 1.3.

1. FUNCTIONS AND CONFIGURATION

1.3 Servo amplifier standard specifications

Item		Servo amplifier MR-JN-□		10A	20A	40A	10A1	20A1
Output	Rated voltage	3-phase 170VAC						
	Rated current [A]	1.1	1.6	2.8	1.1	1.6		
Main circuit power supply	Voltage/frequency	1-phase 200VAC to 230VAC, 50/60Hz				1-phase 100VAC to 120VAC, 50/60Hz		
	Rated current [A]	1.5	2.4	4.5	3.0	5.0		
	Permissible voltage fluctuation	1-phase 170VAC to 253VAC				1-phase 85VAC to 132VAC		
	Permissible frequency fluctuation	Within ±5%						
	Power supply capacity	Refer to section 10.2						
	Inrush current	Refer to section 10.5						
Control circuit power supply	Voltage	24VDC						
	Rated current [A]	0.5						
	Permissible voltage fluctuation	Within ±10%						
	Power consumption [W]	10						
Interface power supply	Voltage	24VDC ±10%						
	Power supply capacity [A]	0.2 (Note)						
Control System		Sine-wave PWM control, current control system						
Dynamic brake		Built-in						
Protective functions		Overcurrent shut-off, regenerative overvoltage shut-off, overload shut-off (electronic thermal relay), servo motor overheat protection, encoder error protection, regenerative error protection, undervoltage, instantaneous power failure protection, overspeed protection, excessive error protection						
Structure		Natural-cooling, open (IP rating: IP20)						
Close mounting		When mounting the servo amplifiers closely, operate them at the ambient temperature of 0°C to 45°C or at 75% or less of the effective load ratio.						
Environmental conditions	Ambient temperature	In operation	[°C]	0 to 55 (non-freezing)				
			[°F]	32 to 131 (non-freezing)				
		In storage	[°C]	-20 to 65 (non-freezing)				
			[°F]	-4 to 149 (non-freezing)				
	Ambient humidity	In operation	90%RH or less (non-condensing)					
		In storage						
	Ambience	Indoors (no direct sunlight) Free from corrosive gas, flammable gas, oil mist, dust and dirt						
Altitude	Max. 1000m (3280 ft) above sea level							
Vibration	5.9 [m/s ²] or less, 10 to 55Hz (directions of X, Y and Z axes)							
Mass	[kg]	0.6	0.6	0.7	0.6	0.6		
	[lb]	1.32	1.32	1.54	1.32	1.32		

Note. 0.2A is the value applicable when all I/O signals are used. The current capacity can be decreased by reducing the number of I/O points.

1. FUNCTIONS AND CONFIGURATION

Item		Servo amplifier MR-JN-□		10A	20A	40A	10A1	20A1
Position control mode	Max. input pulse frequency		1Mpps (for differential receiver), 200kpps (for open collector)					
	Command pulse multiplying factor (electronic gear)		Electronic gear A/B, A: 1 to 65535, B: 1 to 65535, 1/50 < A/B < 500					
	In-position range setting		0 to ±65535pulse (command pulse unit)					
	Error excessive		±3 rotations					
	Torque limit		Parameter setting					
Internal speed control mode	Speed command input		Parameter setting					
	Speed control range		1:5000					
	Speed fluctuation ratio		±0.01% or less (load fluctuation 0 to 100%) 0% (power fluctuation ±10%)					
	Torque limit		Parameter setting					
Internal torque control mode	Torque command input		Parameter setting					
	Speed limit		Parameter setting					
Positioning mode	Command method	Point table method	Operating specification		Positioning by specifying the point table No. (7 points)			
			Position command input		Set in point table. One-point feed length setting range: ±1[μm] to ±999.999[mm]			
			Speed command input		Acceleration/deceleration time constant is set in point table. S-pattern acceleration/deceleration time constant is set in parameter No. PC03.			
		System		Signed absolute value command system, Incremental value command system				
		Program method		Program language (programmed by MR Configurator). Program capacity: 120 steps				
		Position command input		Setting by program language. One-point feed length setting range: ±1[μm] to ±999.999[mm]				
	Speed command input		Servo motor speed, acceleration/deceleration time constant and S-pattern acceleration/deceleration time constant are set by program language. S-pattern acceleration/deceleration time constant is also settable by parameter No. PC03.					
	System		Signed absolute value command system, signed incremental value command system					
	Operation mode	Automatic operation mode	Point table method	One-time positioning operation		Point table number input, position data input system One-time positioning operation is performed in accordance with position and speed commands.		
				Automatic continuous positioning operation		Varied speed operation (2 to 7 speeds), Automatic continuous positioning operation (2 to 7 points)		
		Program method		Setting by programming language				
	Manual operation mode	JOG		JOG operation is performed in accordance with parameter-set speed command by contact input.				
		Manual pulse generator		Manual feed is made by manual pulse generator. Command pulse multiplication: ×1, ×10 or ×100 is selected using parameter.				
	Home position return mode	Dog type		Home position return is made starting with Z-phase pulse after passage of proximity dog. Home position return direction is selectable. Home position shift value is settable. Home position address is settable. Automatic at-dog home position return, Automatic stroke return function				
		Count type		Home position return is made by counting encoder pulses after contact with proximity dog. Home position return direction is selectable. Home position shift value is settable. Home position address is settable. Automatic at-dog home position return, Automatic stroke return function				
		Data set type		Home position return is made without dog. Home position is settable at any position by manual operation, etc. Home position address is settable.				
Stopper type		Home position return is made by pressing machine part against stroke end. Home position return direction is selectable. Home position address is settable.						
Home position ignorance (Servo-on position as home position)		Position where servo-on (SON) is switched on is defined as home position. Home position address is settable.						
Dog type rear end reference		Home position return is made with respect to the rear end of proximity dog. Home position return direction is selectable. Home position shift value is settable. Home position address is settable. Automatic at-dog home position return, Automatic stroke return function						
Count type front end reference		Home position return is made with respect to the front end of proximity dog. Home position return direction is selectable. Home position shift value is settable. Home position address is settable. Automatic at-dog home position return, Automatic stroke return function						
Dog cradle type		Home position return is made with respect to the front end of a proximity dog by the first Z-phase pulse. Home position return direction is selectable. Home position shift value is settable. Home position address is settable. Automatic at-dog home position return, Automatic stroke return function						
Other functions		Backlash function, Overtravel prevention using external limit switch Software stroke limit						

1. FUNCTIONS AND CONFIGURATION

1.4 Function list

The following table lists the functions of this servo. For details of the functions, refer to the reference field.

Function	Description	(Note 1) Control mode	Reference
Position control mode	This servo is used as position control servo.	P	Section 3.2.1 Section 3.6.1
Internal speed control mode	This servo is used as internal speed control servo.	S	Section 3.2.2 Section 3.6.2
Internal torque control mode	This servo is used as internal torque control servo.	T	Section 3.2.3 Section 3.6.3
Position/internal speed control change mode	Using input device, control can be switched between position control and internal speed control.	P/S	Section 3.6.4
Internal speed/internal torque control change mode	Using input device, control can be switched between internal speed control and internal torque control.	S/T	Section 3.6.5
Internal torque/position control change mode	Using input device, control can be switched between internal torque control and position control.	T/P	Section 3.6.6
Positioning mode (Point table method) (Note 2)	Positioning operation is performed by selecting 7 point tables which are set in advance, in accordance with the set value. Select the point table using an external input signal.	CP	Section 13.3
Positioning mode (Program method) (Note 2)	Positioning operation is performed by selecting a program from 8 programs which are created in advance. Select the program using an external input signal.	CL	Section 13.4
Home position return mode (Note 2)	Dog type, count type, data set type, stopper type, home position ignorance, dog type rear end reference, count type front end reference, dog cradle type	CP/CL	Section 13.6
High-resolution encoder	The servo motor is equipped with high-resolution encoder of 131072 pulses/rev.	P, S, T CP/CL	
Gain changing function	Gains can be changed using an input device or gain changing conditions (servo motor speed, etc.)	P, S CP/CL	Section 7.3
Advanced vibration suppression control	This function suppresses vibration of an arm end or residual vibration.	P CP/CL	Section 7.2.4
Adaptive filter II	This function sets the filter characteristics automatically by the one-touch tuning to suppress vibration of a mechanical system.	P, S CP/CL	Section 7.2.2
Low-pass filter	This function is effective for suppressing high-frequency resonance which occurs as the servo system response is increased.	P, S CP/CL	Section 7.2.5
Electronic gear	Input pulses can be multiplied by 1/50 to 500.	P	Section 4.1.7
	Position command can be multiplied by 1/131 to 1000. Electronic gear setting range can be changed by changing the number of virtual pulses per servo motor revolution.	CP/CL	Section 13.7.1 (3)
One-touch tuning	The gain of the servo amplifier can be adjusted by the push button on the front panel.	P, S CP/CL	Section 6.1
Auto tuning	This function optimizes the servo gain automatically as load applied to the servo motor shaft changes.	P, S CP/CL	Section 6.3
Position smoothing	Smooth acceleration is enabled in response to input pulse.	P	Section 4.2.3
S-pattern acceleration/ deceleration time constant	Smooth acceleration and deceleration are enabled.	S, T	Section 4.3.2 Parameter No. PC03
		CP/CL	Section 13.7.3 (2) Parameter No. PC03
Regenerative option	Regenerative option is used when the built-in regenerative resistor of the servo amplifier does not have sufficient regenerative capability for the regenerative power generated.	P, S, T CP/CL	Section 11.2
Alarm history clear	This function clears alarm history and the number of tough drive performed.	P, S, T CP/CL	Parameter No. PC11

1. FUNCTIONS AND CONFIGURATION

Function	Description	(Note 1) Control mode	Reference
Command pulse selection	Command input pulse form can be selected from among three different types.	P	Section 4.1.11
Input signal selection	Forward rotation start (ST1), reverse rotation start (ST2), servo-on (SON) and other input device can be assigned to specific pins.	P, S, T CP/CL	Parameter No. PD02 to PD14
Output signal selection	Ready (RD), trouble (ALM) or other output device can be assigned to specific pins.	P, S, T CP/CL	Parameter No. PD15 to PD18
Torque limit	The torque generated by the servo motor can be limited by setting a parameter.	P, S CP/CL	Section 3.6.1 (4)
Speed limit	Servo motor speed can be limited by setting a parameter.	T	Section 3.6.3 (3) Parameter No. PC05 to PC08, PC31 to PC34
Status display	Servo status is shown on the 3-digit, 7-segment LED display	P, S, T CP/CL	Section 5.3
External I/O signal display	ON/OFF statuses of external I/O signals are shown on the display.	P, S, T CP/CL	Section 5.8
Output signal (DO) forced output	Output signal can be forced on/off independently of the servo status. Use this function for output signal wiring check, etc.	P, S, T CP/CL	Section 5.9
Test operation mode	JOG operation, positioning operation, motor-less operation, DO forced output, forced tough drive operation, program operation, and single-step feed. Note that MR Configurator MRZJW3-SETUP221E is necessary for the positioning operation, program operation or single-step feed. The single-step feed is supported by servo amplifier with software version B0 or later, and MR Configurator with software version C4 or later.	P, S, T CP/CL	Section 5.10
		CP/CL	Section 13.10
MR Configurator	Parameter setting, test operation, status display, etc. can be performed using a personal computer.	P, S, T CP/CL	Section 11.4 Section 13.8 to 13.10
Tough drive function	This function continues the operation not to stop a machine in such situation when normally an alarm is activated. Three types of the tough drive function are available: overload tough drive, vibration tough drive and instantaneous power failure tough drive. However, the overload tough drive is valid only in the position control mode or positioning mode.	P, S CP/CL	Section 7.1
Limit switch	The servo motor travel region can be limited using the forward rotation stroke end (LSP)/reverse rotation stroke end (LSN).	P, S	Section 3.5
		CP/CL	Section 13.2.3
Software limit (Note2)	The travel region is limited using parameters in terms of address. The function similar to that of a limit switch is limited by parameter.	CP/CL	Section 13.7.5 (4)
Drive recorder function (Note2)	This function records the state transition before and after the alarm occurrence for the predetermined period of time by always monitoring the servo status. The recorded data can be confirmed on the graph display screen by clicking the "Drive recorder display" button on the alarm history display screen of MR Configurator.	P, S, T CP/CL	Section 4.3.4

Note 1. P: Position control mode, S: Internal speed control mode, T: Internal torque control mode,

P/S: Position/internal speed control change mode, S/T: Internal speed/internal torque control change mode,

T/P: Internal torque/position control change mode

CP: Positioning mode (Point table method), CL: Positioning mode (Program method)

2. It is supported by servo amplifier with software version B0 or later.

1. FUNCTIONS AND CONFIGURATION

1.5 Model code definition

(1) Rating plate

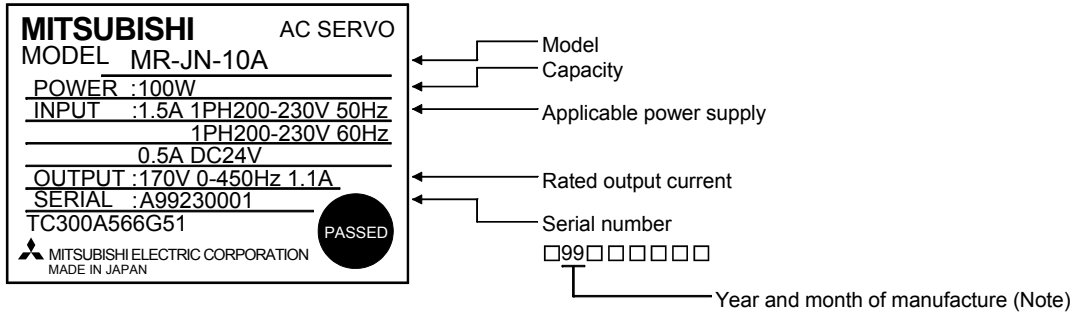

Note. The year and month when the servo amplifier is manufactured are written down in the serial number of the rating plate. The year and month of manufacture are indicated by the last one digit of the year and 1 to 9, X(10), Y(11), Z(12). For September 2009, the serial number is like "SERIAL: 99".

(2) Model

The following explains the description of models. Not all the combination of symbols exists.

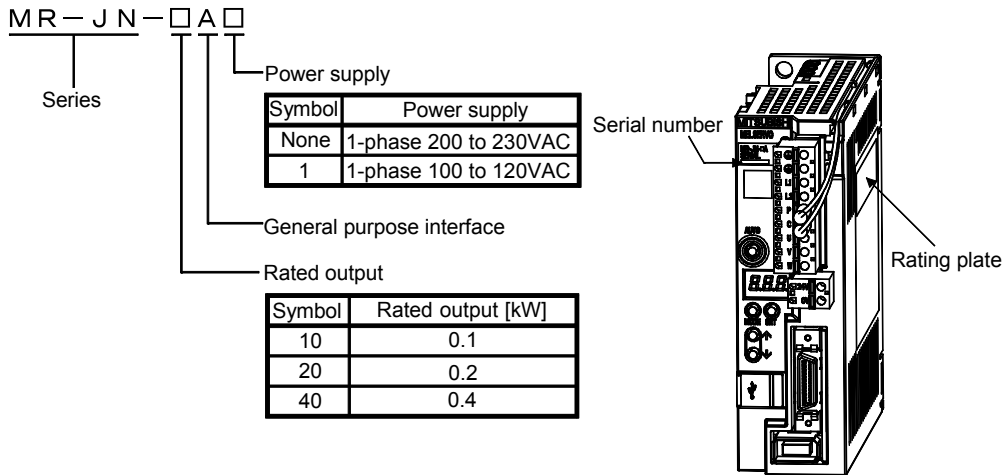

1.6 Combination with servo motor

The following table lists combinations of servo amplifiers and servo motors. The following combinations also apply to servo motors with an electromagnetic brake.

Servo amplifier	Servo motors	
	HF-KN□	HF-KP□G1/G5/G7
MR-JN-10A(1)	053 · 13	
MR-JN-20A(1)	23	
MR-JN-40A	43	

1. FUNCTIONS AND CONFIGURATION

1.7 Parts identification

Name/Application	Detailed explanation
Serial number	
Main circuit power supply connector (CNP1) Connect the input power supply/built-in regenerative resistor/regenerative option/servo motor/earth.	Section 3.1 Section 3.3
Charge lamp Lit to indicate that the main circuit is charged. While this lamp is lit, do not reconnect the cables.	
Rating plate	Section 1.5
One-touch tuning button (AUTO) Press this button to perform the one-touch tuning.	Section 6.1
Control circuit power supply connector (CNP2) Connect the control circuit power supply.	Section 3.1 Section 3.3
Display The 3-digit, 7-segment LED shows the servo status and alarm number	Chapter 5
Operation section Used to perform status display, diagnosis, alarm, point table and parameter setting operations. <p>MODE SET Used to set data. Used to change the mode.</p> <p>Used to change the display or data in each mode.</p>	Chapter 5
I/O signal connector (CN1) Used to connect digital I/O signals.	Section 3.2 Section 3.4
USB communication connector (CN3) Connect the personal computer.	Section 11.4
Encoder connector (CN2) Used to connect the servo motor encoder.	Section 3.4 Section 11.1

1. FUNCTIONS AND CONFIGURATION

1.8 Configuration including auxiliary equipment

POINT
<ul style="list-style-type: none"> Equipment other than the servo amplifier and servo motor are optional or recommended products.

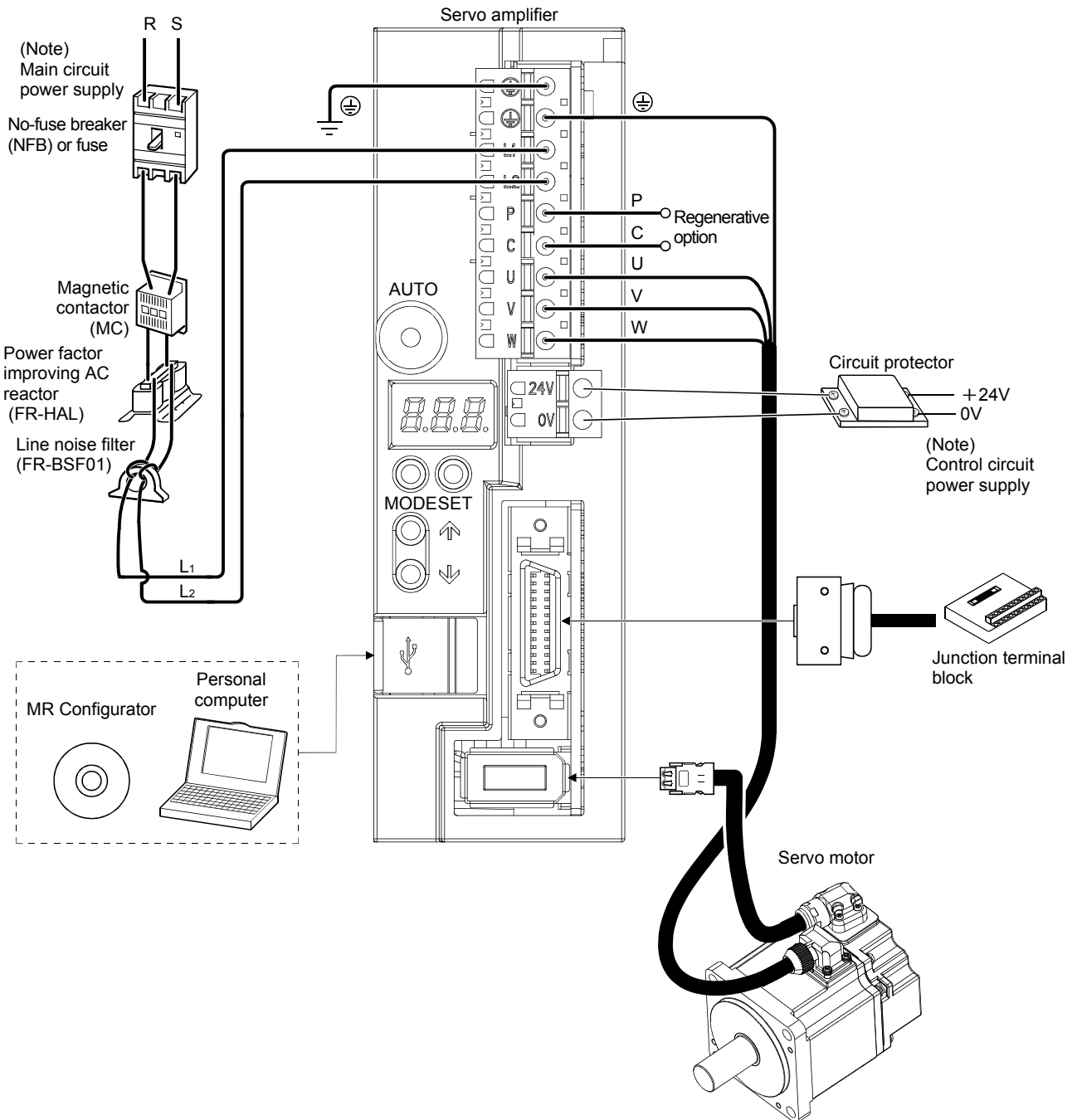

Note. Refer to section 1.3 for the power supply specification.

2. INSTALLATION

2. INSTALLATION



WARNING

- Be sure to ground the servo amplifier to prevent electric shocks.



CAUTION

- Carry the products in a suitable way according to their weight.
- Stacking in excess of the limited number of product packages is not allowed.
- Do not hold the lead of the built-in regenerative resistor when transporting a servo amplifier.
- Install the equipment to incombustibles. Installing them directly or close to combustibles will lead to a fire.
- Install the equipment in a load-bearing place in accordance with this Instruction Manual.
- Do not get on or put heavy load on the equipment to prevent injury.
- Use the equipment within the specified environmental condition range. (For details of the environmental condition, refer to section 1.3.)
- Provide an adequate protection to prevent conductive matters like screws or combustible matters like oil from entering the servo amplifier.
- Do not block the intake/exhaust ports of the servo amplifier. Otherwise, a fault may occur.
- Do not subject the servo amplifier to drop impact or shock loads as they are precision equipment.
- Do not install or operate a faulty servo amplifier.
- When the product has been stored for an extended period of time, consult Mitsubishi.
- When handling the servo amplifier, be careful about the edged parts such as the corners of the servo amplifier.
- Be sure to install the servo amplifier on a metal control panel.

2. INSTALLATION

2.1 Installation direction and clearances



CAUTION

- The equipment must be installed in the specified direction. Otherwise, a fault may occur.
- Leave specified clearances between the servo amplifier and control box inside walls or other equipment.

A regenerative resistor is mounted on the back of this servo amplifier. The regenerative resistor causes a temperature rise of 100°C relative to the ambient temperature. Fully examine heat dissipation and installation position before installing the servo amplifier.

(1) Installation of one servo amplifier

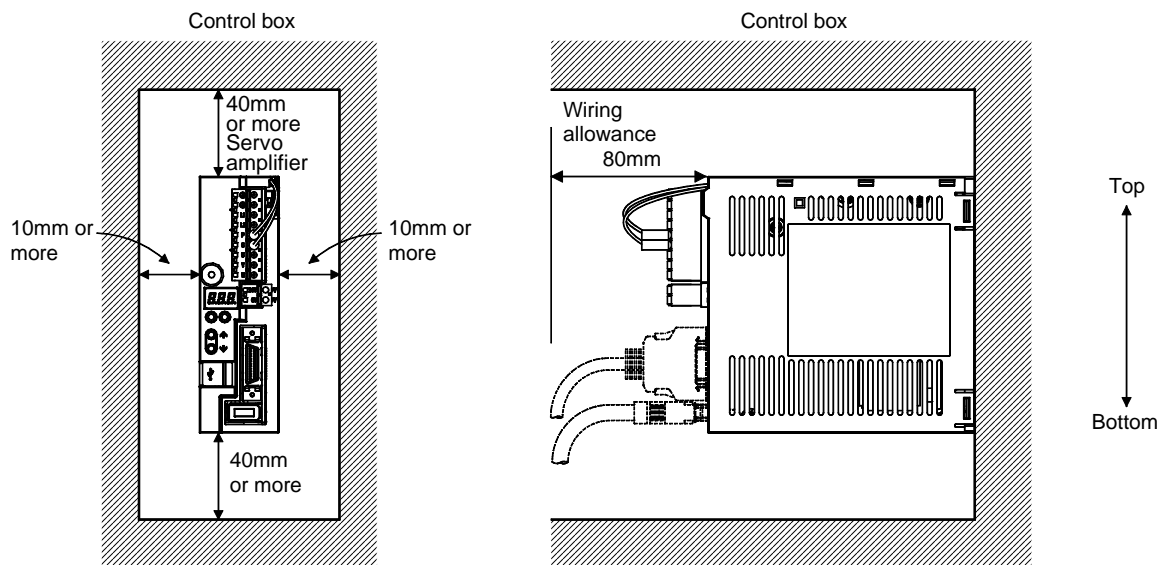

2. INSTALLATION

(2) Installation of two or more servo amplifiers

POINT
<ul style="list-style-type: none"> MR-JN series servo amplifier with any capacity can be mounted closely together.

Leave a large clearance between the top of the servo amplifier and the internal surface of the control box, and install a cooling fan to prevent the internal temperature of the control box from exceeding the environmental conditions.

When installing the servo amplifiers closely, leave a clearance of 1mm between the adjacent servo amplifiers in consideration of mounting tolerances.

In this case, operate the servo amplifiers at the ambient temperature of 0°C to 45°C or at 75% or less of the effective load ratio.

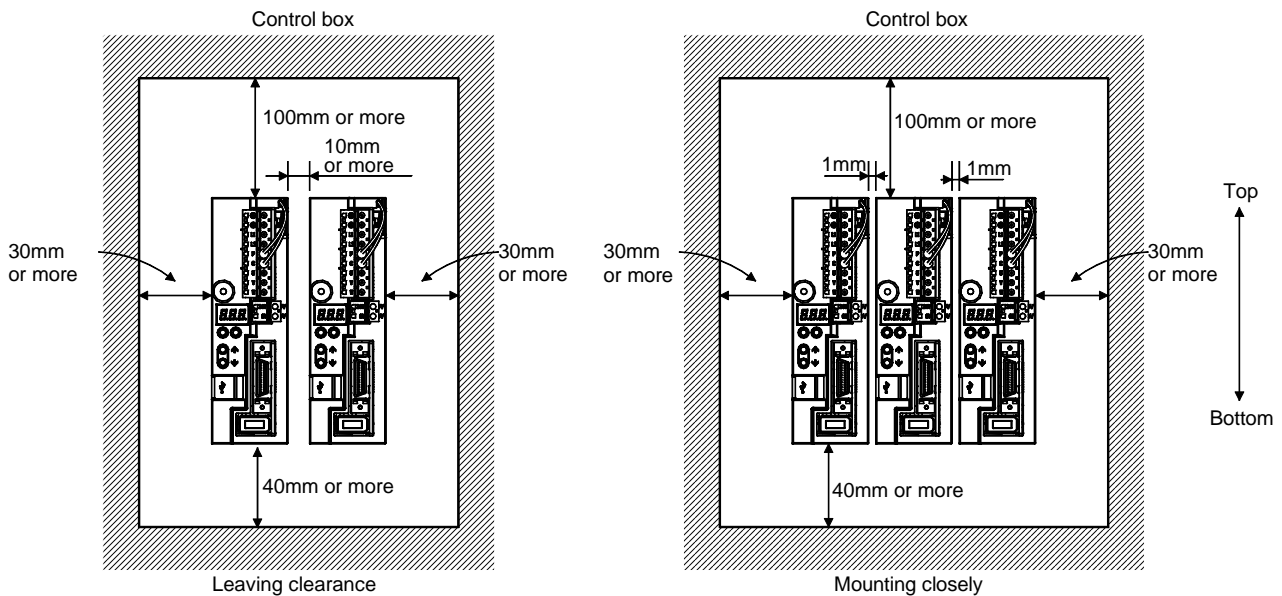

(3) Others

When using heat generating equipment such as the regenerative option, install them with full consideration of heat generation so that the servo amplifier is not affected.

Install the servo amplifier on a perpendicular wall in the correct vertical direction.

2.2 Keep out foreign materials

- (1) When installing the unit in a control box, prevent drill chips and wire fragments from entering the servo amplifier.
- (2) Prevent oil, water, metallic dust, etc. from entering the servo amplifier through openings in the control box or a cooling fan installed on the ceiling.
- (3) When installing the control box in a place where toxic gas, dirt and dust exist, conduct an air purge (force clean air into the control box from outside to make the internal pressure higher than the external pressure) to prevent such materials from entering the control box.

2. INSTALLATION

2.3 Cable stress

- (1) The way of clamping the cable must be fully examined so that flexing stress and cable's own weight stress are not applied to the cable connection.
- (2) For use in any application where the servo motor moves, fix the cables (encoder, power supply, brake) with having some slack from the connector connection part of the servo motor to avoid putting stress on the connector connection part. Use the optional encoder cable within the flexing life range. Use the power supply and brake wiring cables within the flexing life of the cables.
- (3) Avoid any probability that the cable sheath might be cut by sharp chips, rubbed by a machine corner or stamped by workers or vehicles.
- (4) For installation on a machine where the servo motor moves, the flexing radius should be made as large as possible. Refer to section 10.4 for the flexing life.

2.4 Inspection items



- Before starting maintenance and/or inspection, turn off the power and wait for 15 minutes or more until the charge lamp turns off. Otherwise, an electric shock may occur. In addition, always confirm from the front of the servo amplifier whether the charge lamp is off or not.
- Due to risk of electric shock, only qualified personnel should attempt inspection. For repair and parts replacement, contact your local sales office.

POINT

- Do not perform insulation resistance test on the servo amplifier as damage may result.
- Do not disassemble and/or repair the equipment on customer side.

It is recommended to make the following checks periodically.

- (1) Check for loose screws. Retighten any loose screws.
- (2) Check the cables and the wires for scratches and cracks. Perform periodic inspection according to operating conditions.

2. INSTALLATION

2.5 Parts having service lives

Service lives of the following parts are listed below. However, the service life varies depending on operating methods and environmental conditions. If any fault is found in the parts, they must be replaced immediately regardless of their service lives. For parts replacement, please contact your local sales office.

Part name	Life guideline
Smoothing capacitor	10 years
Relay	Number of power-on and number of forced stop times: 100,000 times

(1) Smoothing capacitor

Affected by ripple currents, etc. and deteriorates in characteristic. The life of the capacitor greatly depends on ambient temperature and operating conditions. The capacitor will reach the end of its life in 10 years of continuous operation in normal air-conditioned environment.

(2) Relays

Their contacts will wear due to switching currents and contact faults occur. Relays reach the end of their life when the cumulative number of power-on and forced stop times is 100,000, which depends on the power supply capacity.

3. SIGNALS AND WIRING

3. SIGNALS AND WIRING



WARNING

- Any person who is involved in wiring should be fully competent to do the work.
- Before wiring, turn off the power and wait for 15 minutes or more until the charge lamp turns off. Otherwise, an electric shock may occur. In addition, always confirm from the front of the servo amplifier whether the charge lamp is off or not.
- Ground the servo amplifier and the servo motor securely.
- Do not attempt to wire the servo amplifier and servo motor until they have been installed. Otherwise, you may get an electric shock.
- The cables should not be damaged, stressed excessively, loaded heavily, or pinched. Otherwise, you may get an electric shock.



CAUTION

- Before unplugging the CNP1 connector from the servo amplifier, disconnect the lead of the built-in regenerative resistor from the CNP1 connector.
- Wire the equipment correctly and securely. Otherwise, the servo motor may operate unexpectedly resulting in injury.
- Connect cables to correct terminals to prevent a burst, fault, etc.
- Ensure that polarity (+, -) is correct. Otherwise, a burst, damage, etc. may occur.
- The surge absorbing diode installed to the DC relay designed for control output should be fitted in the specified direction. Otherwise, the signal is not output due to a fault, disabling the emergency stop and other protective circuits.

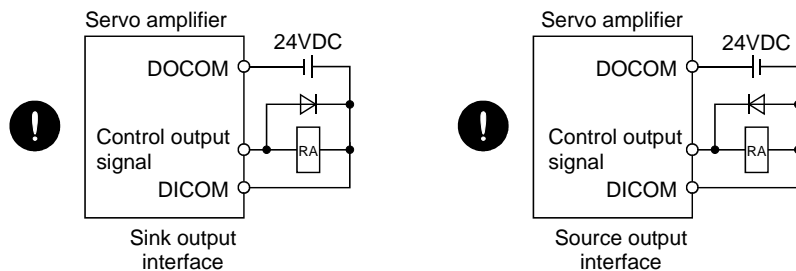

- Use a noise filter, etc. to minimize the influence of electromagnetic interference, which may be given to electronic equipment used near the servo amplifier.
- Do not install a power capacitor, surge suppressor or radio noise filter (FR-BIF option) with the power line of the servo motor.
- When using the regenerative resistor, switch power off with the alarm signal. Otherwise, a transistor fault or the like may overheat the regenerative resistor, causing a fire.
- Do not modify the equipment.
- During power-on, do not open or close the motor power line. Otherwise, an abnormal operation or malfunction may occur.

3. SIGNALS AND WIRING

3.1 Input power supply circuit



CAUTION

- Always connect a magnetic contactor (MC) between the main circuit power supply, and L1 and L2 of the servo amplifier to configure a circuit that shuts down the power on the servo amplifier's power supply side. If a magnetic contactor (MC) is not connected, continuous flow of a large current may cause a fire when the servo amplifier malfunctions.
- Use the trouble (ALM) to switch power off. Otherwise, a regenerative transistor fault or the like may overheat the regenerative resistor, causing a fire.
- Before unplugging the CNP1 connector from the servo amplifier, disconnect the lead of the built-in regenerative resistor from the CNP1 connector. Otherwise, the lead of the built-in regenerative resistor may break.
- For main circuit power supply of servo amplifier, check the model of servo amplifier and input the correct voltage. If a voltage exceeding the upper limit shown in the servo amplifier input voltage specification is input, the servo amplifier malfunctions.

Wire the main circuit power supply as shown below so that the servo-on (SON) turns off as soon as alarm occurrence is detected and power is shut off.

A no-fuse breaker (NFB) must be used with the input cables of the main circuit power supply.

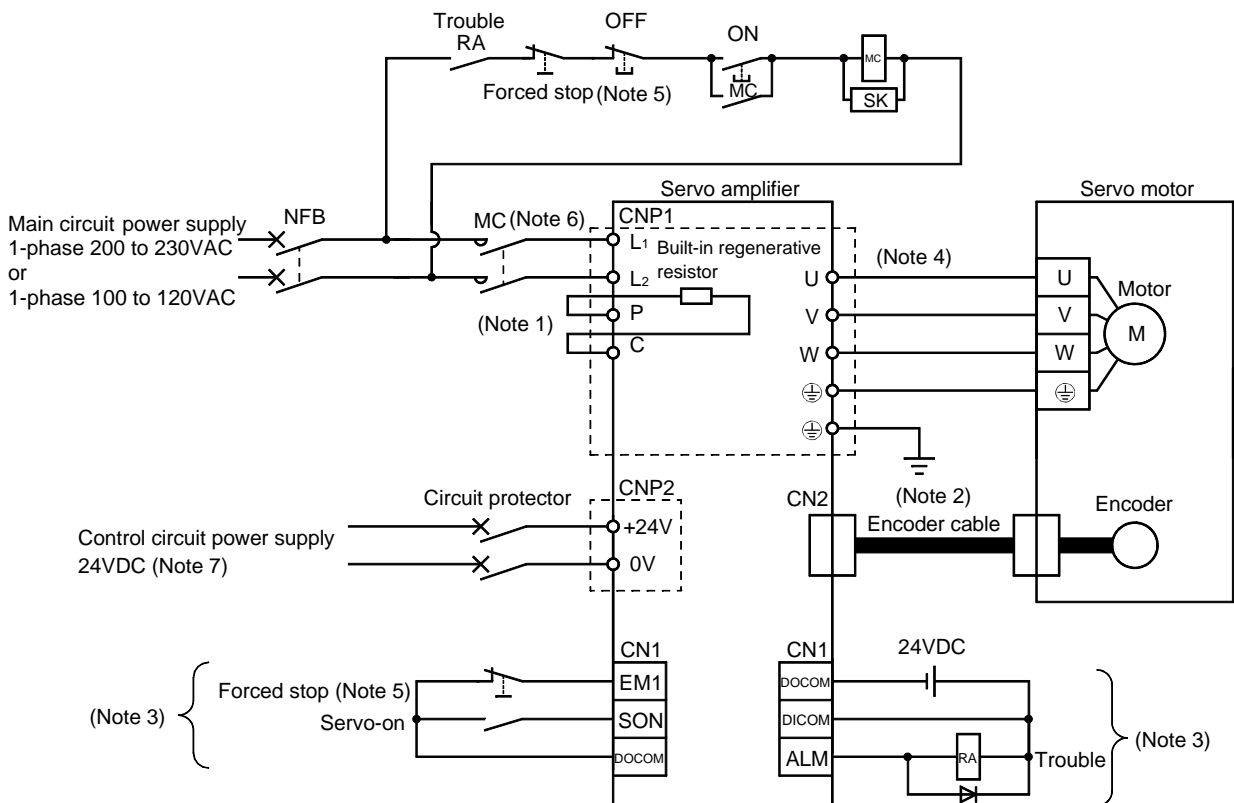

3. SIGNALS AND WIRING

- Note 1. The built-in regenerative resistor is provided for MR-JN-20A(1) and MR-JN-40A. (Factory-wired.) When using the regenerative option, refer to section 11.2.
2. For encoder cable, use of the option cable is recommended. Refer to section 11.1 for selection of the cable.
 3. For the sink I/O interface.
For the source I/O interface, refer to section 3.8.3.
 4. Refer to section 3.10.
 5. Configure the circuit to shut off the main circuit power supply by an external sequence simultaneously with the forced stop (EM1) turning OFF.
 6. Be sure to use a magnetic contactor (MC) with an operation delay time of 80ms or less. The operation delay time is the time interval between current being applied to the coil until closure of contacts.
 7. Use the enhanced insulation power supply for the control circuit power supply 24VDC. In addition, do not use a power supply with an output voltage starting time of one second or more.

3. SIGNALS AND WIRING

3.2 I/O signal connection example

3.2.1 Position control mode

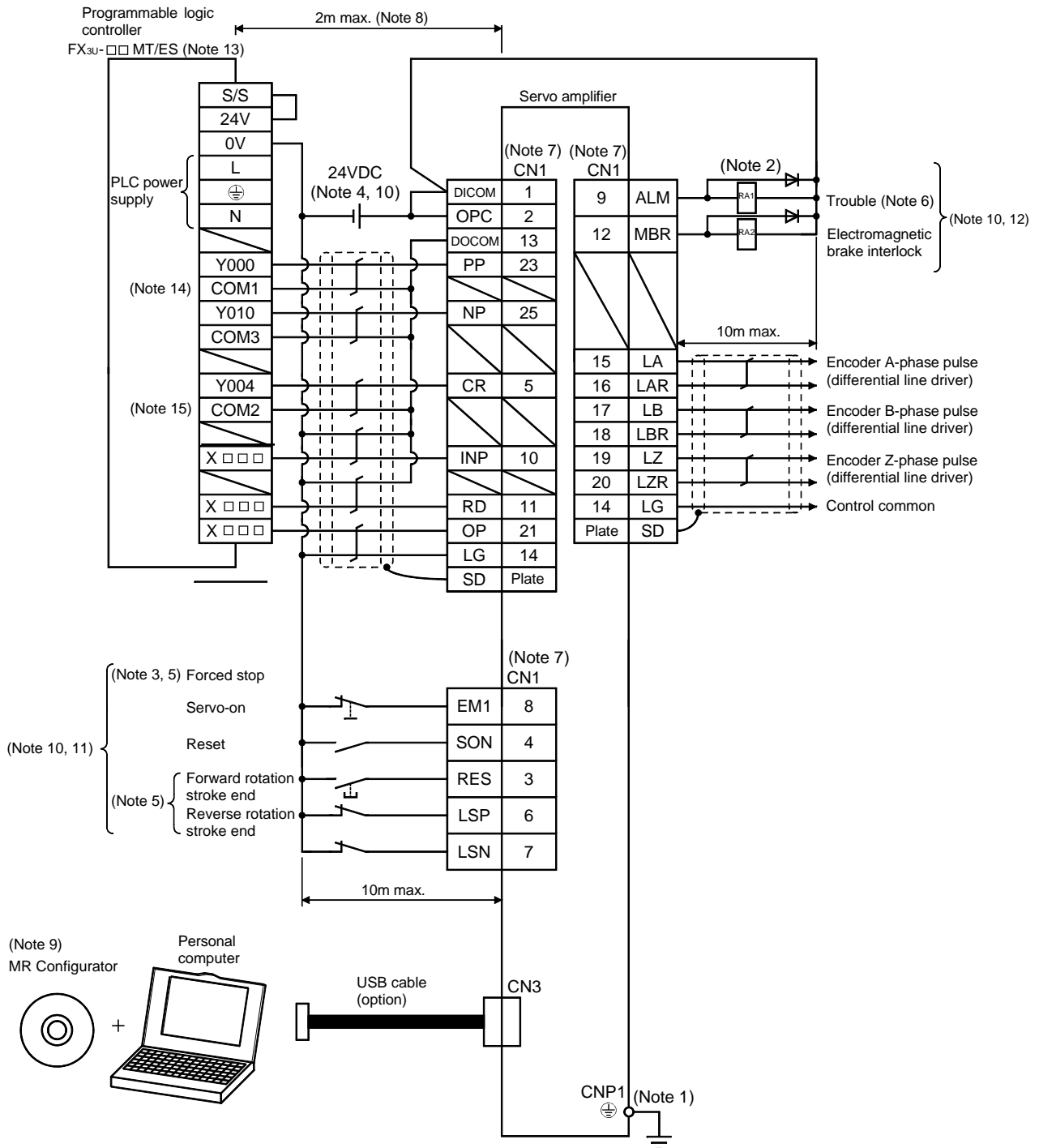

3. SIGNALS AND WIRING

- Note 1. To prevent an electric shock, always connect the protective earth (PE) terminal (terminal marked ) of the servo amplifier main circuit power supply connector (CNP1) to the protective earth (PE) of the control box.
2. Connect the diode in the correct direction. If it is connected reversely, the servo amplifier will be faulty and will not output signals, disabling the emergency stop and other protective circuits.
 3. The forced stop switch (normally closed contact) must be installed.
 4. Supply 24VDC \pm 10% 200mA current for interfaces from the outside. 200mA is the value applicable when all I/O signals are used. The current capacity can be decreased by reducing the number of I/O points. Refer to section 3.8.2 (1) that gives the current value necessary for the interface.
 5. When starting operation, always switch on the forced stop (EM1) or the forward/reverse rotation stroke end (LSP, LSN). (Normally closed contacts)
 6. Trouble (ALM) turns on in normal alarm-free condition. When this signal is switched off (at occurrence of an alarm), the output of the programmable logic controller should be stopped by the sequence program.
 7. The pins with the same signal name are connected in the servo amplifier.
 8. This length applies to the command input pulses in the open collector system. The wirings can be extended up to 10m when using positioning modules with the differential line driver system.
 9. Use MRZJW3-SETUP221E (C4 or later).
 10. This diagram is for sink I/O interface. For source I/O interface, refer to section 3.8.3.
 11. The assigned signals can be changed using the settings of parameter No. PD03 to PD14.
 12. The assigned signals can be changed using the settings of parameter No. PD15 to PD18.
 13. Select the number of I/O points of the programmable logic controllers in accordance with the system.
 14. It is COM0 for FX3U-16MT/ES.
 15. It is COM4 for FX3U-16MT/ES.

3. SIGNALS AND WIRING

3.2.2 Internal speed control mode

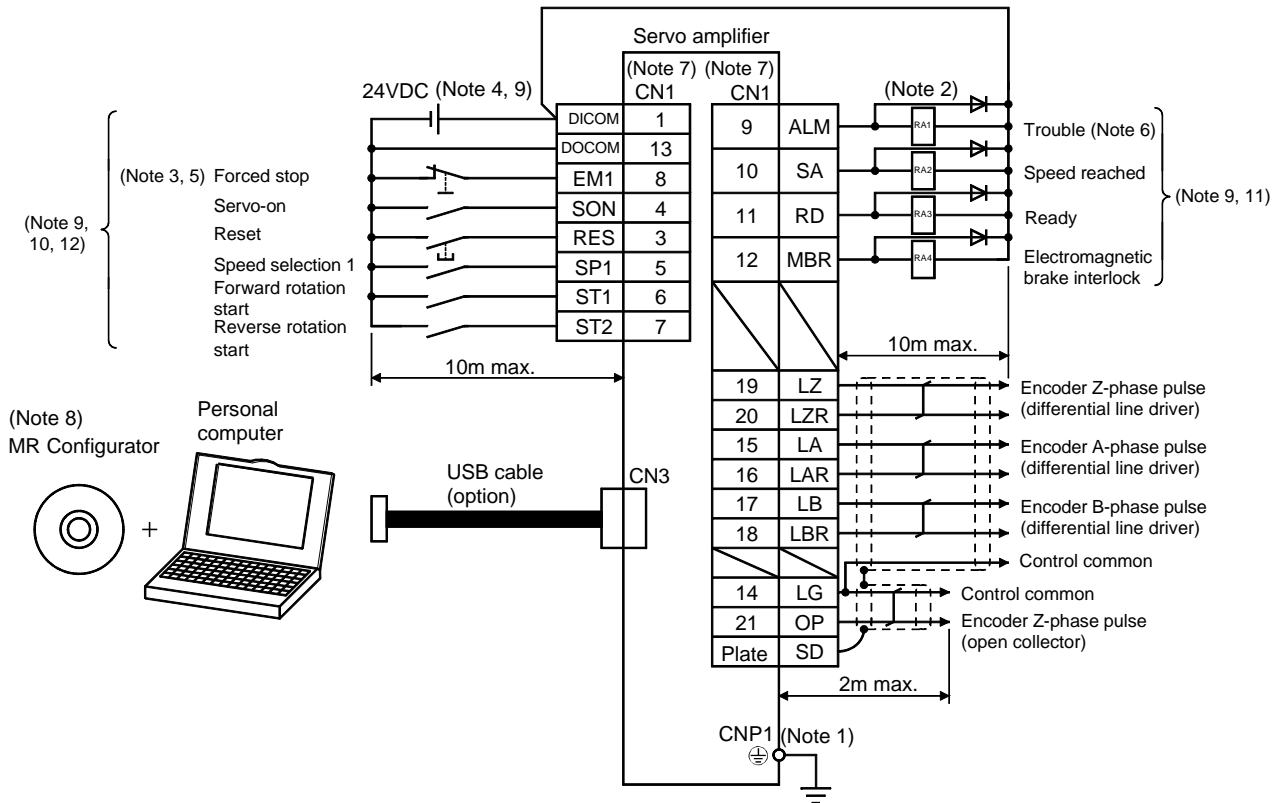

- Note 1. To prevent an electric shock, always connect the protective earth (PE) terminal (terminal marked \oplus) of the servo amplifier main circuit power supply connector (CNP1) to the protective earth (PE) of the control box.
2. Connect the diode in the correct direction. If it is connected reversely, the servo amplifier will be faulty and will not output signals, disabling the emergency stop and other protective circuits.
3. The forced stop switch (normally closed contact) must be installed.
4. Supply $24\text{VDC} \pm 10\%$ 200mA current for interfaces from the outside. 200mA is the value applicable when all I/O signals are used. The current capacity can be decreased by reducing the number of I/O points. Refer to section 3.8.2 (1) that gives the current value necessary for the interface.
5. When starting operation, always switch on the forced stop (EM1). (Normally closed contacts)
6. Trouble (ALM) turns on in normal alarm-free condition.
7. The pins with the same signal name are connected in the servo amplifier.
8. Use MRZJW3-SETUP221E (C4 or later).
9. This diagram is for sink I/O interface. For source I/O interface, refer to section 3.8.3.
10. The assigned signals can be changed using the settings of parameter No. PD03 to PD14.
11. The assigned signals can be changed using the settings of parameter No. PD15 to PD18.
12. The forward rotation stroke end (LSP) and the reverse rotation stroke end (LSN) automatically switch ON if not assigned to the external input signals.

3. SIGNALS AND WIRING

3.2.3 Internal torque control mode

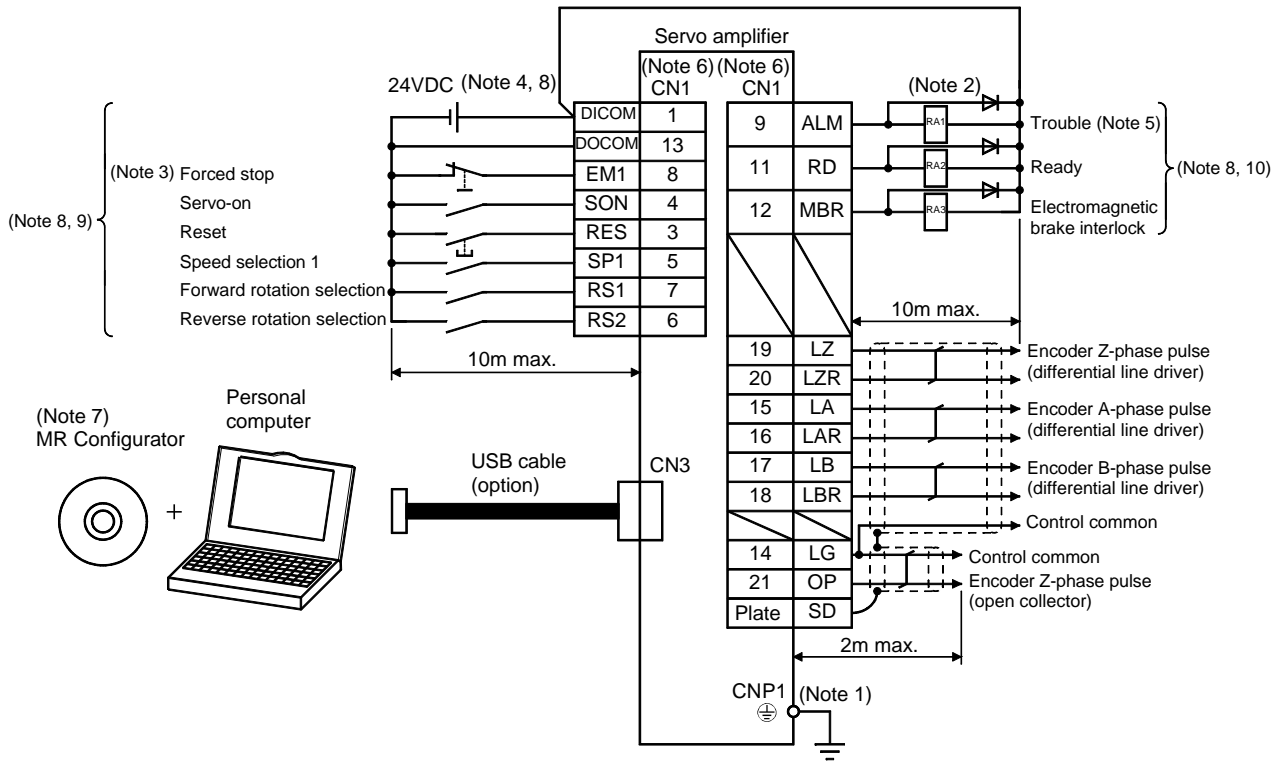

- Note 1. To prevent an electric shock, always connect the protective earth (PE) terminal (terminal marked \oplus) of the servo amplifier main circuit power supply connector (CNP1) to the protective earth (PE) of the control box.
- Note 2. Connect the diode in the correct direction. If it is connected reversely, the servo amplifier will be faulty and will not output signals, disabling the emergency stop and other protective circuits.
- Note 3. The forced stop switch (normally closed contact) must be installed.
- Note 4. Supply $24\text{VDC} \pm 10\%$ 200mA current for interfaces from the outside. 200mA is the value applicable when all I/O signals are used. The current capacity can be decreased by reducing the number of I/O points. Refer to section 3.8.2 (1) that gives the current value necessary for the interface.
- Note 5. Trouble (ALM) turns on in normal alarm-free condition.
- Note 6. The pins with the same signal name are connected in the servo amplifier.
- Note 7. Use MRZJW3-SETUP221E (C4 or later).
- Note 8. This diagram is for sink I/O interface. For source I/O interface, refer to section 3.8.3.
- Note 9. The assigned signals can be changed using the settings of parameter No. PD03 to PD14.
- Note 10. The assigned signals can be changed using the settings of parameter No. PD15 to PD18.

3. SIGNALS AND WIRING

3.3 Explanation of power supply system

3.3.1 Signal explanations

POINT
▪ For the layout of connector, refer to chapter 9 OUTLINE DRAWINGS.

Abbreviation	Connection target (application)	Description
L ₁ L ₂	Main circuit power supply	Supply the following power supply. MR-JN-10A/20A/40A : 1-phase 200VAC to 230VAC, 50/60Hz MR-JN-10A1/20A1 : 1-phase 100VAC to 120VAC, 50/60Hz
P C	Built-in regenerative resistor or regenerative option	1) MR-JN-10A(1) When using the regenerative option, connect it to P and C. (MR-JN-10A(1) does not provide a built-in regenerative resistor.) 2) MR-JN-20A(1)/40A When using the servo amplifier built-in regenerative resistor, connect the built-in regenerative resistor to P and C. (Factory-wired.) When using a regenerative option, ▪ first, disconnect the wirings to P and C, ▪ second, remove the built-in regenerative resistor from the servo amplifier, ▪ finally, connect the regenerative option to P and C.
+24V 0V	Control circuit power supply	Supply 24VDC power to +24V and 0V.
U V W	Servo motor power	Connect to the servo motor power supply terminals (U, V, W). During power-on, do not open or close the motor power line. Otherwise, an abnormal operation or malfunction may occur.
⊕	Protective earth (PE)	Connect to the earth terminal of the servo motor and to the protective earth (PE) of the control box to perform grounding.

3.3.2 Power-on sequence

(1) Power-on procedure

- 1) Always wire the power supply as shown in above section 3.1 using the magnetic contactor with the main circuit power supply (single-phase: L₁, L₂). Configure up an external sequence to switch off the magnetic contactor as soon as an alarm occurs.
- 2) The servo amplifier can accept the servo-on (SON) about 1 to 2s after the main circuit power supply is switched on. Therefore, when the servo-on (SON) is switched on simultaneously with the main circuit power supply, the base circuit will switch on in about 1 to 2s, and the ready (RD) will switch on in further about 5ms, making the servo amplifier ready to operate. (Refer to paragraph (2) of this section.)
If the main circuit power supply is OFF while the servo-on (SON) is ON, the display on the servo amplifier shows the corresponding warning. Switching ON the main circuit power supply discards the warning and the servo amplifier operates normally.
- 3) When the reset (RES) is switched on, the base circuit is shut off and the servo motor shaft coasts.

3. SIGNALS AND WIRING

(2) Timing chart

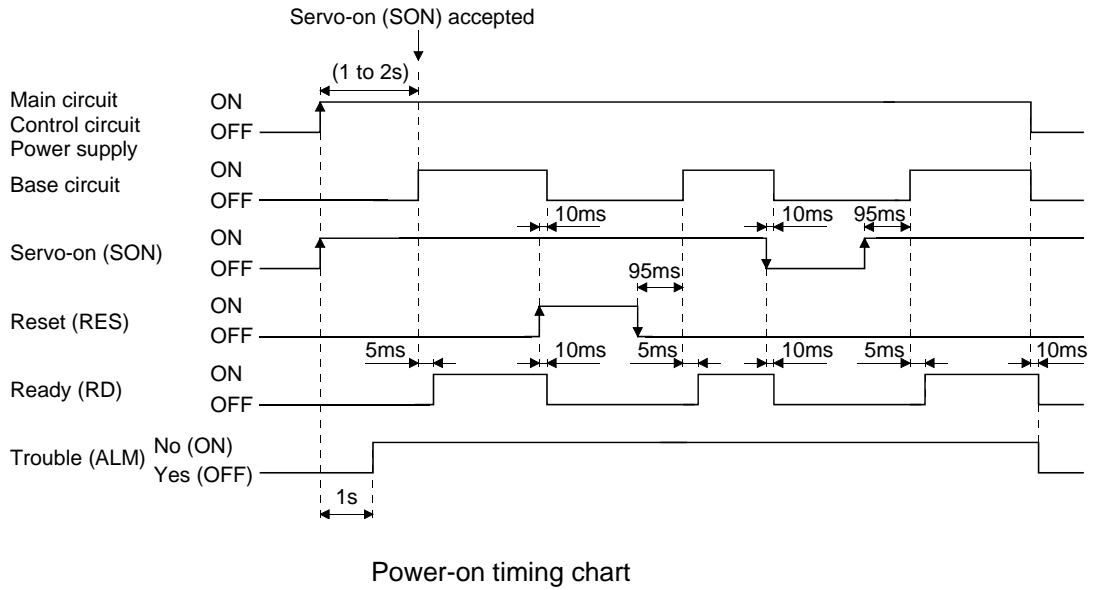

(3) Forced stop



CAUTION

· Configure a circuit which interlocks with an external emergency stop switch in order to stop the operation immediately and shut off the power.

Configure a circuit that shuts off the main circuit power as soon as EM1 is turned off at a forced stop. When EM1 is turned off, the dynamic brake is operated to stop the servo motor immediately. At this time, the display shows the servo forced stop warning (E6.1).

During the normal operation, do not use the forced stop (EM1) to alternate stop and run. The service life of the servo amplifier may be shortened.

Also, the servo motor rotates simultaneously with the reset of the forced stop if a forward rotation start (ST1) or the reverse rotation start (ST2) is ON, or if a pulse train is input during the forced stop. Be sure to shut off the operation instruction during the forced stop.

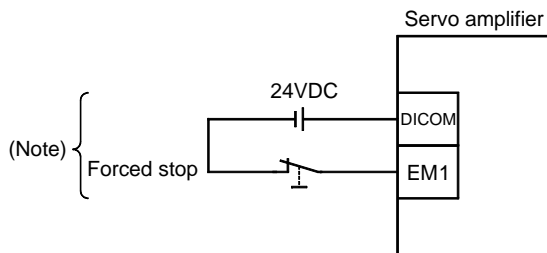

Note. For the sink I/O interface. For the source I/O interface, refer to section 3.8.3.

3. SIGNALS AND WIRING

3.3.3 CNP1 and CNP2 wiring method

POINT
▪ Refer to section 11.5, for the wire sizes used for wiring.

Use the supplied servo amplifier power supply connectors for wiring of CNP1 and CNP2.

(1) Servo amplifier power supply connectors

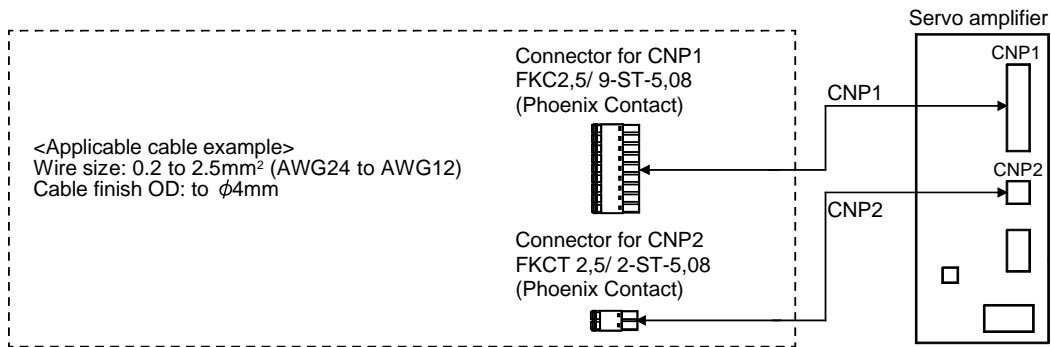

3. SIGNALS AND WIRING

(2) Termination of the wires

(a) Solid wire

The wire can be used just by stripping the sheath.

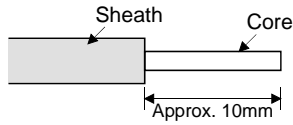

(b) Twisted wire

1) Inserting the wires directly to the terminals

Use the wire after stripping the sheath and twisting the core. At this time, take care to avoid a short caused by the loose wires of the core and the adjacent pole. Do not solder the core as it may cause a contact fault.

2) Putting the wires together using a ferrule

Use a ferrule as follows.

Cable size		Ferrule type		Crimping tool	Manufacturer
[mm ²]	AWG	For one wire	For two wires		
1.25/1.5	16	AI 1,5-10 BK	AI-TWIN 2 × 1,5-10 BK	CRIMPFOX ZA 3	Phoenix Contact
2/2.5	14	AI 2,5-10 BK			

Cut off the exceeding wire from the tip of the ferrule, leaving 0.5mm or less.

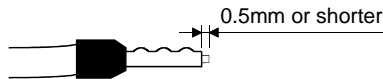

When using the ferrule for two wires, plug the wires in a direction in which insulating sleeves do not interfere the adjacent poles.

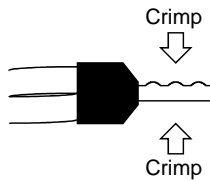

3. SIGNALS AND WIRING

(3) Connection method

(a) Inserting the wires directly to the terminals

Insert the wire to the very end of the hole while pressing the button by a tool such as a small flat-blade screwdriver.

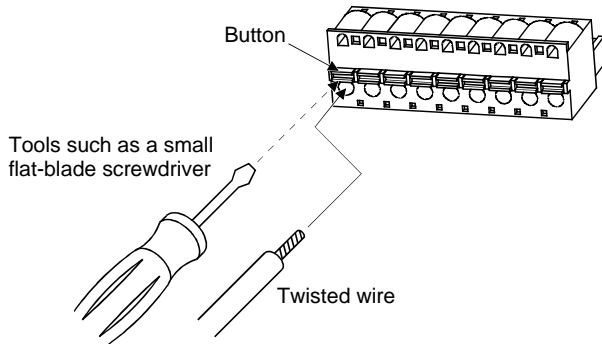

(b) Putting the wires together using a ferrule

Insert the wire as the uneven side of the crimped ferrule collar faces the button side.

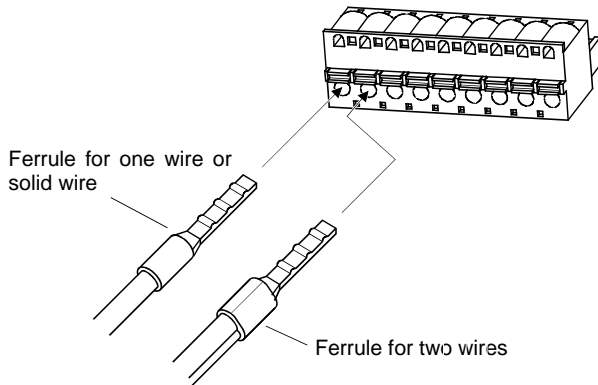

Use a ferrule for two wires when inserting two wires into one hole.

3. SIGNALS AND WIRING

3.4 Connectors and signal arrangements

POINT
<ul style="list-style-type: none"> ▪ For the positioning mode, refer to section 13.2.2. ▪ The pin configurations of the connectors are as viewed from the cable connector wiring section. ▪ Refer to (2) of this section for CN1 signal assignment.

(1) Signal arrangement

The front view shown below is that of MR-JN-20A(1) or smaller. Refer to chapter 9 OUTLINE DRAWINGS for the appearances and connector layouts of the other servo amplifiers.

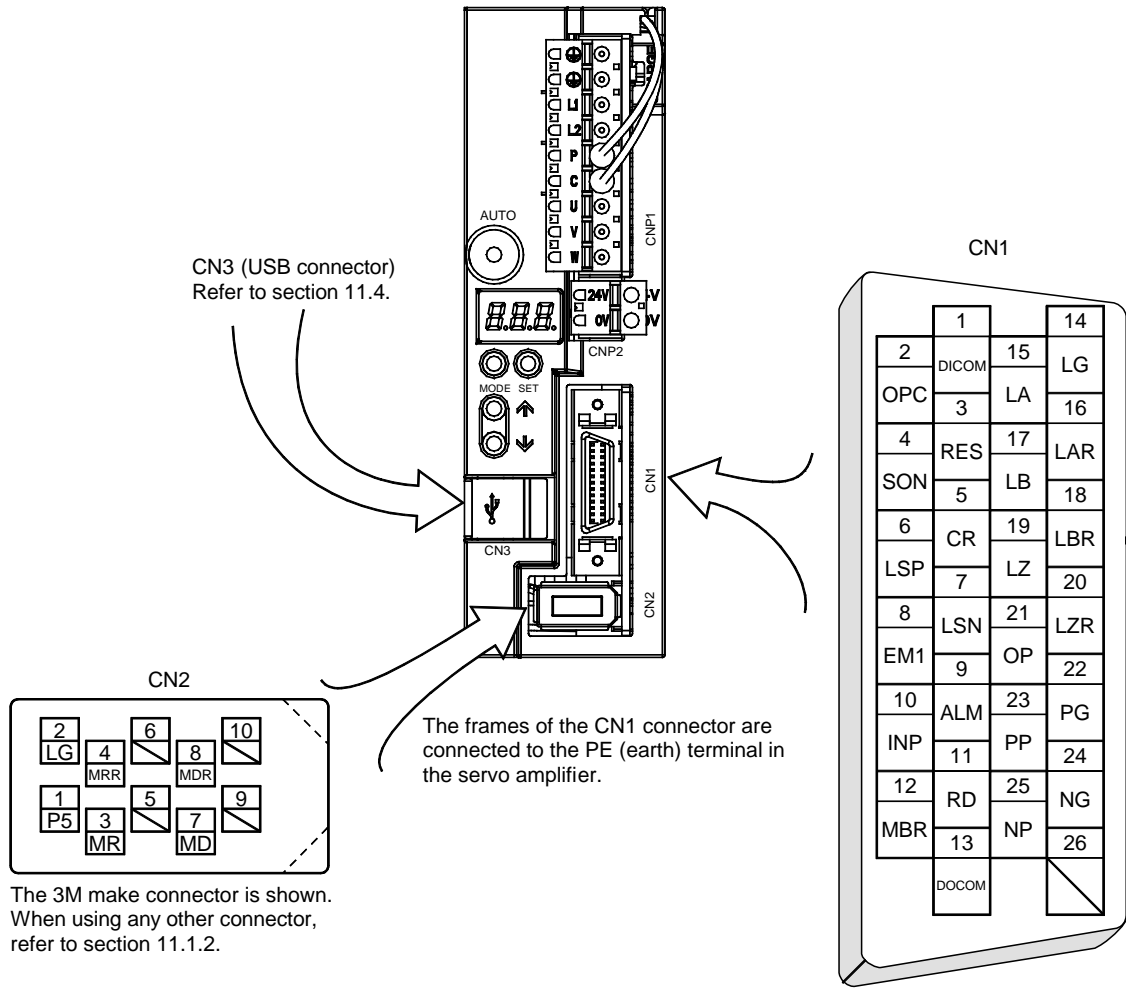

Signal assignments shown above are in the case of position control mode.

3. SIGNALS AND WIRING

(2) CN1 signal assignment

The signal assignment of connector changes with the control mode as indicated below;

For the pins which are given parameter No. in the related parameter column, their signals can be changed using those parameters.

Pin No.	(Note 1) I/O	(Note 2) I/O signals in control modes						Related parameter No.
		P	P/S	S	S/T	T	T/P	
1		DICOM	DICOM	DICOM	DICOM	DICOM	DICOM	
2		OPC	OPC/-				-/OPC	
3	I	RES	RES	RES	RES	RES	RES	PD03 • PD04
4	I	SON	SON	SON	SON	SON	SON	PD05 • PD06
5	I	CR	CR/SP1	SP1	SP1/SP1	SP1	SP1/CR	PD07 • PD08
6	I	LSP	LSP/ST1	ST1	ST1/RS2	RS2	RS2/LSP	PD09 • PD10
7	I	LSN	LSN/ST2	ST2	ST2/RS1	RS1	RS1/LSN	PD11 • PD12
8	I	EM1	EM1	EM1	EM1	EM1	EM1	PD13 • PD14
9	O	ALM	ALM	ALM	ALM	ALM	ALM	PD15
10	O	INP	INP/SA	SA	SA/-		-/INP	PD16
11	O	RD	RD	RD	RD	RD	RD	PD17
12	O	MBR	MBR	MBR	MBR	MBR	MBR	PD18
13		DOCOM	DOCOM	DOCOM	DOCOM	DOCOM	DOCOM	
14		LG	LG	LG	LG	LG	LG	
15	O	LA	LA	LA	LA	LA	LA	
16	O	LAR	LAR	LAR	LAR	LAR	LAR	
17	O	LB	LB	LB	LB	LB	LB	
18	O	LBR	LBR	LBR	LBR	LBR	LBR	
19	O	LZ	LZ	LZ	LZ	LZ	LZ	
20	O	LZR	LZR	LZR	LZR	LZR	LZR	
21	O	OP	OP	OP	OP	OP	OP	
22	I	PG	PG/-				-/PG	
23	I	PP	PP/-				-/PP	
24	I	NG	NG/-				-/NG	
25	I	NP	NP/-				-/NP	
26								

Note 1. I: Input signal, O: Output signal

2. P: Position control mode, S: Internal speed control mode, T: Internal torque control mode,

P/S: Position/internal speed control change mode, S/T: Internal speed/internal torque control change mode,

T/P: Internal torque/position control change mode

3. SIGNALS AND WIRING

(3) Explanation of abbreviations

Abbreviation	Signal name	Abbreviation	Signal name
SON	Servo-on	ALM	Trouble
RES	Reset	INP	In-position
PC	Proportion control	SA	Speed reached
EM1	Forced stop	MBR	Electromagnetic brake interlock
CR	Clear	TLC	Limiting torque
ST1	Forward rotation start	VLC	Limiting speed
ST2	Reverse rotation start	WNG	Warning
RS1	Forward rotation selection	ZSP	Zero speed
RS2	Reverse rotation selection	MTTR	During tough drive
TL1	Internal torque limit selection	CDPS	During variable gain selection
LSP	Forward rotation stroke end	OP	Encoder Z-phase pulse (open collector)
LSN	Reverse rotation stroke end	LZ	Encoder Z-phase pulse
SP1	Speed selection 1	LZR	(differential line driver)
SP2	Speed selection 2	LA	Encoder A-phase pulse
SP3	Speed selection 3	LAR	(differential line driver)
LOP	Control change	LB	Encoder B-phase pulse
CDP	Gain changing	LBR	(differential line driver)
PP	Forward/reverse rotation pulse train	DICOM	Digital I/F power supply input
NP		OPC	Open collector power input
PG		DOCOM	Digital I/F common
NG		LG	Control common
RD		SD	Shield

3. SIGNALS AND WIRING

3.5 Signal explanations

POINT
▪ For the positioning mode, refer to section 13.2.3.

For the I/O interfaces (symbols in I/O division column in the table), refer to section 3.8.2.

In the control mode field of the table

P : Position control mode, S: Internal speed control mode, T: Internal torque control mode

○ : Denotes that the signal may be used in the initial setting status.

△ : Denotes that the signal may be used by setting the corresponding parameter No. PD02 to PD18.

The pin numbers in the connector pin No. column are those in the initial status.

(1) I/O devices

(a) Input devices

Device	Symbol	Connector pin No.	Functions/Applications	I/O division	Control mode																									
					P	S	T																							
Servo-on	SON	CN1-4	When SON is turned on, the power is supplied to the base circuit and the servo amplifier is ready to operate (servo-on). When SON is turned off, the power to the base circuit is shut off and the servo motor coasts. Set parameter No. PD01 to "□□□4" to switch this signal on (keep terminals connected) automatically in the servo amplifier.	DI-1	○	○	○																							
Reset	RES	CN1-3	When RES is turned on for 50ms or longer, an alarm can be reset. Some alarms cannot be deactivated by the reset (RES). Refer to section 8.1. Turning RES on in an alarm-free status shuts off the base circuit. The base circuit is not shut off when "□□1□" is set in parameter No. PD20. This device is not designed to make a stop. Do not turn it ON during operation.	DI-1	○	○	○																							
Forward rotation stroke end	LSP	CN1-6	To start operation, turn LSP/LSN on. Turn it off to bring the motor to a sudden stop and make it servo-locked. Set "□□□1" in parameter No. PD20 to make a slow stop. (Refer to section 4.4.2.)	DI-1	○	△																								
			<table border="1" style="margin-left: auto; margin-right: auto;"> <thead> <tr> <th colspan="2">(Note) Input device</th> <th colspan="2">Operation</th> </tr> <tr> <th>LSP</th> <th>LSN</th> <th>CCW direction</th> <th>CW direction</th> </tr> </thead> <tbody> <tr> <td>1</td> <td>1</td> <td>○</td> <td>○</td> </tr> <tr> <td>0</td> <td>1</td> <td style="border: none;"></td> <td>○</td> </tr> <tr> <td>1</td> <td>0</td> <td>○</td> <td style="border: none;"></td> </tr> <tr> <td>0</td> <td>0</td> <td style="border: none;"></td> <td style="border: none;"></td> </tr> </tbody> </table>	(Note) Input device		Operation		LSP	LSN	CCW direction	CW direction	1	1	○	○	0	1		○	1	0	○		0	0					
(Note) Input device		Operation																												
LSP	LSN	CCW direction	CW direction																											
1	1	○	○																											
0	1		○																											
1	0	○																												
0	0																													
Reverse rotation stroke end	LSN	CN1-7	Note. 0: off 1: on When LSP or LSN turns OFF, an external stroke limit warning (99. □) occurs, and warning (WNG) turns OFF. However, when using WNG, set parameter No. PD15 to PD18 to make it usable. In the internal speed control mode, LSP and LSN turns ON automatically if they are not assigned to the external input signals.																											

3. SIGNALS AND WIRING

Device	Symbol	Connector pin No.	Functions/Applications	I/O division	Control mode																			
					P	S	T																	
Internal torque limit selection	TL1		<p>The internal torque limit 2 (parameter No. PC14) becomes valid by turning TL1 on.</p> <p>The forward torque limit (parameter No. PA11) and the reverse torque limit (parameter No. PA12) are always valid.</p> <p>The smallest torque limit among the valid forward and reverse torque limits is the actual torque limit value.</p> <table border="1"> <thead> <tr> <th rowspan="2">(Note) Input device</th> <th rowspan="2">Comparison between limit values</th> <th colspan="2">Valid torque limit value</th> </tr> <tr> <th>Forward rotation</th> <th>Reverse rotation</th> </tr> </thead> <tbody> <tr> <td>0</td> <td></td> <td>Parameter No. PA11</td> <td>Parameter No. PA12</td> </tr> <tr> <td rowspan="2">1</td> <td>Parameter No. PC14 > Parameter No. PA11 Parameter No. PA12</td> <td>Parameter No. PA11</td> <td>Parameter No. PA12</td> </tr> <tr> <td>Parameter No. PC14 < Parameter No. PA11 Parameter No. PA12</td> <td>Parameter No. PC14</td> <td>Parameter No. PC14</td> </tr> </tbody> </table> <p>Note. 0: off 1: on</p>	(Note) Input device	Comparison between limit values	Valid torque limit value		Forward rotation	Reverse rotation	0		Parameter No. PA11	Parameter No. PA12	1	Parameter No. PC14 > Parameter No. PA11 Parameter No. PA12	Parameter No. PA11	Parameter No. PA12	Parameter No. PC14 < Parameter No. PA11 Parameter No. PA12	Parameter No. PC14	Parameter No. PC14	DI-1	△	△	△
(Note) Input device	Comparison between limit values	Valid torque limit value																						
		Forward rotation	Reverse rotation																					
0		Parameter No. PA11	Parameter No. PA12																					
1	Parameter No. PC14 > Parameter No. PA11 Parameter No. PA12	Parameter No. PA11	Parameter No. PA12																					
	Parameter No. PC14 < Parameter No. PA11 Parameter No. PA12	Parameter No. PC14	Parameter No. PC14																					
Forward rotation start	ST1		<p>Used to start the servo motor in any of the following directions.</p> <table border="1"> <thead> <tr> <th colspan="2">(Note) Input device</th> <th rowspan="2">Servo motor starting direction</th> </tr> <tr> <th>ST2</th> <th>ST1</th> </tr> </thead> <tbody> <tr> <td>0</td> <td>0</td> <td>Stop (servo lock)</td> </tr> <tr> <td>0</td> <td>1</td> <td>CCW</td> </tr> <tr> <td>1</td> <td>0</td> <td>CW</td> </tr> <tr> <td>1</td> <td>1</td> <td>Stop (servo lock)</td> </tr> </tbody> </table> <p>Note. 0: off 1: on</p> <p>If both ST1 and ST2 are switched on or off during operation, the servo motor will be decelerated to a stop according to parameter No. PC02 setting and servo-locked.</p> <p>When "□□1" is set in parameter No. PC23, the servo motor is not servo-locked after deceleration to a stop.</p>	(Note) Input device		Servo motor starting direction	ST2	ST1	0	0	Stop (servo lock)	0	1	CCW	1	0	CW	1	1	Stop (servo lock)	DI-1	○		
(Note) Input device		Servo motor starting direction																						
ST2	ST1																							
0	0	Stop (servo lock)																						
0	1	CCW																						
1	0	CW																						
1	1	Stop (servo lock)																						
Reverse rotation start	ST2																							
Forward rotation selection	RS1		<p>Used to select any of the following servo motor torque generation directions.</p> <table border="1"> <thead> <tr> <th colspan="2">(Note) Input device</th> <th rowspan="2">Torque generation direction</th> </tr> <tr> <th>RS2</th> <th>RS1</th> </tr> </thead> <tbody> <tr> <td>0</td> <td>0</td> <td>Torque is not generated.</td> </tr> <tr> <td>0</td> <td>1</td> <td>Forward rotation in driving mode / reverse rotation in regenerative mode</td> </tr> <tr> <td>1</td> <td>0</td> <td>Reverse rotation in driving mode / forward rotation in regenerative mode</td> </tr> <tr> <td>1</td> <td>1</td> <td>Torque is not generated.</td> </tr> </tbody> </table> <p>Note. 0: off 1: on</p> <p>Torque is not generated if both RS1 and RS2 are switched ON or OFF during the operation.</p>	(Note) Input device		Torque generation direction	RS2	RS1	0	0	Torque is not generated.	0	1	Forward rotation in driving mode / reverse rotation in regenerative mode	1	0	Reverse rotation in driving mode / forward rotation in regenerative mode	1	1	Torque is not generated.	DI-1	○		
(Note) Input device		Torque generation direction																						
RS2	RS1																							
0	0	Torque is not generated.																						
0	1	Forward rotation in driving mode / reverse rotation in regenerative mode																						
1	0	Reverse rotation in driving mode / forward rotation in regenerative mode																						
1	1	Torque is not generated.																						
Reverse rotation selection	RS2																							

3. SIGNALS AND WIRING

Device	Symbol	Connector pin No.	Functions/Applications	I/O division	Control mode																																																																																
					P	S	T																																																																														
Speed selection 1	SP1		<p><Internal speed control mode> Used to select the command speed for operation. (Max. 8 speeds)</p> <table border="1"> <thead> <tr> <th colspan="3">(Note) Input device</th> <th rowspan="2">Speed command</th> </tr> <tr> <th>SP3</th> <th>SP2</th> <th>SP1</th> </tr> </thead> <tbody> <tr> <td>0</td> <td>0</td> <td>0</td> <td>Internal speed command 0 (parameter No. PC05)</td> </tr> <tr> <td>0</td> <td>0</td> <td>1</td> <td>Internal speed command 1 (parameter No. PC06)</td> </tr> <tr> <td>0</td> <td>1</td> <td>0</td> <td>Internal speed command 2 (parameter No. PC07)</td> </tr> <tr> <td>0</td> <td>1</td> <td>1</td> <td>Internal speed command 3 (parameter No. PC08)</td> </tr> <tr> <td>1</td> <td>0</td> <td>0</td> <td>Internal speed command 4 (parameter No. PC31)</td> </tr> <tr> <td>1</td> <td>0</td> <td>1</td> <td>Internal speed command 5 (parameter No. PC32)</td> </tr> <tr> <td>1</td> <td>1</td> <td>0</td> <td>Internal speed command 6 (parameter No. PC33)</td> </tr> <tr> <td>1</td> <td>1</td> <td>1</td> <td>Internal speed command 7 (parameter No. PC34)</td> </tr> </tbody> </table> <p>Note. 0: off 1: on</p> <p><Internal torque control mode> Used to select the limit speed for operation. (Max. 8 speeds)</p> <table border="1"> <thead> <tr> <th colspan="3">(Note) Input device</th> <th rowspan="2">Speed limit</th> </tr> <tr> <th>SP3</th> <th>SP2</th> <th>SP1</th> </tr> </thead> <tbody> <tr> <td>0</td> <td>0</td> <td>0</td> <td>Internal speed limit 0 (parameter No. PC05)</td> </tr> <tr> <td>0</td> <td>0</td> <td>1</td> <td>Internal speed limit 1 (parameter No. PC06)</td> </tr> <tr> <td>0</td> <td>1</td> <td>0</td> <td>Internal speed limit 2 (parameter No. PC07)</td> </tr> <tr> <td>0</td> <td>1</td> <td>1</td> <td>Internal speed limit 3 (parameter No. PC08)</td> </tr> <tr> <td>1</td> <td>0</td> <td>0</td> <td>Internal speed limit 4 (parameter No. PC31)</td> </tr> <tr> <td>1</td> <td>0</td> <td>1</td> <td>Internal speed limit 5 (parameter No. PC32)</td> </tr> <tr> <td>1</td> <td>1</td> <td>0</td> <td>Internal speed limit 6 (parameter No. PC33)</td> </tr> <tr> <td>1</td> <td>1</td> <td>1</td> <td>Internal speed limit 7 (parameter No. PC34)</td> </tr> </tbody> </table>	(Note) Input device			Speed command	SP3	SP2	SP1	0	0	0	Internal speed command 0 (parameter No. PC05)	0	0	1	Internal speed command 1 (parameter No. PC06)	0	1	0	Internal speed command 2 (parameter No. PC07)	0	1	1	Internal speed command 3 (parameter No. PC08)	1	0	0	Internal speed command 4 (parameter No. PC31)	1	0	1	Internal speed command 5 (parameter No. PC32)	1	1	0	Internal speed command 6 (parameter No. PC33)	1	1	1	Internal speed command 7 (parameter No. PC34)	(Note) Input device			Speed limit	SP3	SP2	SP1	0	0	0	Internal speed limit 0 (parameter No. PC05)	0	0	1	Internal speed limit 1 (parameter No. PC06)	0	1	0	Internal speed limit 2 (parameter No. PC07)	0	1	1	Internal speed limit 3 (parameter No. PC08)	1	0	0	Internal speed limit 4 (parameter No. PC31)	1	0	1	Internal speed limit 5 (parameter No. PC32)	1	1	0	Internal speed limit 6 (parameter No. PC33)	1	1	1	Internal speed limit 7 (parameter No. PC34)	DI-1		○	○
(Note) Input device			Speed command																																																																																		
SP3	SP2			SP1																																																																																	
0	0		0	Internal speed command 0 (parameter No. PC05)																																																																																	
0	0		1	Internal speed command 1 (parameter No. PC06)																																																																																	
0	1		0	Internal speed command 2 (parameter No. PC07)																																																																																	
0	1		1	Internal speed command 3 (parameter No. PC08)																																																																																	
1	0		0	Internal speed command 4 (parameter No. PC31)																																																																																	
1	0	1	Internal speed command 5 (parameter No. PC32)																																																																																		
1	1	0	Internal speed command 6 (parameter No. PC33)																																																																																		
1	1	1	Internal speed command 7 (parameter No. PC34)																																																																																		
(Note) Input device			Speed limit																																																																																		
SP3	SP2	SP1																																																																																			
0	0	0	Internal speed limit 0 (parameter No. PC05)																																																																																		
0	0	1	Internal speed limit 1 (parameter No. PC06)																																																																																		
0	1	0	Internal speed limit 2 (parameter No. PC07)																																																																																		
0	1	1	Internal speed limit 3 (parameter No. PC08)																																																																																		
1	0	0	Internal speed limit 4 (parameter No. PC31)																																																																																		
1	0	1	Internal speed limit 5 (parameter No. PC32)																																																																																		
1	1	0	Internal speed limit 6 (parameter No. PC33)																																																																																		
1	1	1	Internal speed limit 7 (parameter No. PC34)																																																																																		
Speed selection 2	SP2			DI-1		△	△																																																																														
Speed selection 3	SP3			DI-1		△	△																																																																														
Proportion control	PC		<p>When PC is turned on, the type of the speed loop switches from the proportional integral type to the proportional type. If the servo motor at a stop is rotated even one pulse due to any external factor, it generates torque to compensate for a position shift. When the servo motor shaft is to be locked mechanically after positioning completion (stop), switching on the proportion control (PC) upon positioning completion will suppress the unnecessary torque generated to compensate for a position shift. In case of locking the servo motor shaft for a long time, turn on the internal torque limit selection (TL1) simultaneously with the proportion control (PC). Then, set the internal torque limit 2 (parameter No. PC14) in order to make the torque lower than the rating.</p>	DI-1	△	△																																																																															
Forced stop	EM1	CN1-8	<p>When EM1 is turned off (contact between commons is opened), the servo amplifier falls in a forced stop state in which the base circuit is shut off, and the dynamic brake activates. When EM1 is turned on (contact between commons is shorted) in the forced stop state, the state can be reset.</p>	DI-1	○	○	○																																																																														
Clear	CR	CN1-5	<p>When CR is turned on, the droop pulses of the position control counter are cleared on its leading edge. The pulse width should be 10ms or more. The delay amount set in parameter No. PB03 (position command acceleration/deceleration time constant) is also cleared. When parameter No. PD22 is set to "□□□1", the pulses are always cleared while CR is on.</p>	DI-1	○																																																																																

3. SIGNALS AND WIRING

Device	Symbol	Connector pin No.	Functions/Applications	I/O division	Control mode																				
					P	S	T																		
Gain changing	CDP		The values of the load to motor inertia moment ratio and the gains are changed to the value set in parameter No. PB29 to PB34 by turning CDP on.	DI-1	△	△	△																		
Control change	LOP		<p><Position/internal speed control change mode> Used to select the control mode in the position/internal speed control change mode.</p> <table border="1"> <thead> <tr> <th>(Note) LOP</th> <th>Control mode</th> </tr> </thead> <tbody> <tr> <td>0</td> <td>Position</td> </tr> <tr> <td>1</td> <td>Internal speed</td> </tr> </tbody> </table> <p>Note. 0: off 1: on</p> <p><Internal speed/internal torque control change mode> Used to select the control mode in the internal speed/internal torque control change mode.</p> <table border="1"> <thead> <tr> <th>(Note) LOP</th> <th>Control mode</th> </tr> </thead> <tbody> <tr> <td>0</td> <td>Internal speed</td> </tr> <tr> <td>1</td> <td>Internal torque</td> </tr> </tbody> </table> <p>Note. 0: off 1: on</p> <p><Internal torque/position control mode> Used to select the control mode in the internal torque/position control change mode.</p> <table border="1"> <thead> <tr> <th>(Note) LOP</th> <th>Control mode</th> </tr> </thead> <tbody> <tr> <td>0</td> <td>Internal torque</td> </tr> <tr> <td>1</td> <td>Position</td> </tr> </tbody> </table> <p>Note. 0: off 1: on</p>	(Note) LOP	Control mode	0	Position	1	Internal speed	(Note) LOP	Control mode	0	Internal speed	1	Internal torque	(Note) LOP	Control mode	0	Internal torque	1	Position	DI-1	Refer to Functions/Applications.		
(Note) LOP	Control mode																								
0	Position																								
1	Internal speed																								
(Note) LOP	Control mode																								
0	Internal speed																								
1	Internal torque																								
(Note) LOP	Control mode																								
0	Internal torque																								
1	Position																								

(b) Output devices

Device	Symbol	Connector pin No.	Functions/Applications	I/O division	Control mode		
					P	S	T
Trouble	ALM	CN1-9	ALM turns off when power is switched off or the protective circuit is activated to shut off the base circuit. When there is no alarm, ALM turns on approximately 1s after power-on.	DO-1	○	○	○
Ready	RD	CN1-11	RD turns on when the servo motor is ready for the operation after turning on the servo-on (SON).	DO-1	○	○	○
In-position	INP	CN1-10	INP turns on when the number of droop pulses is in the preset in-position range. The in-position range can be changed using parameter No. PA10. When the in-position range is increased, may be kept connected during low-speed rotation. INP turns on when servo-on turns on. If parameter No. PA04 is set to "□ □ 1" and the overload tough drive function is enabled, the INP ON time in the overload tough drive is delayed. The delay time can be limited by parameter No. PC26.	DO-1	○		

3. SIGNALS AND WIRING

Device	Symbol	Connector pin No.	Functions/Applications	I/O division	Control mode		
					P	S	T
Speed reached	SA	CN1-10	SA turns on when the servo motor speed has nearly reached the preset speed. When the preset speed is 20r/min or less, SA always turns on. SA does not turn on even when the servo-on (SON) is turned off or the servo motor speed by the external force reaches the preset speed while both the forward rotation start (ST1) and the reverse rotation start (ST2) are off.	DO-1		○	
Limiting speed	VLC		VLC turns ON when the speed reaches the value limited by any of the internal speed limits 0 to 7 (parameter No. PC05 to PC08, and PC31 to PC34) in the internal torque control mode. VLC turns off when servo-on (SON) turns off.	DO-1			△
Limiting torque	TLC		TLC turns ON when the generated torque reaches the value set to the forward torque limit (parameter No. PA11), the reverse torque limit (parameter No. PA12) or the internal torque limit 2 (parameter No. PC14).	DO-1	△	△	
Zero speed	ZSP		ZSP turns on when the servo motor speed is zero speed (50r/min) or less. Zero speed can be changed using parameter No. PC10. Example Zero speed is 50r/min <p>Forward rotation direction OFF level 70r/min ON level 50r/min Servo motor speed 0r/min Reverse rotation direction ON level 50r/min OFF level 70r/min Zero speed (ZSP) ON OFF</p>	DO-1	△	△	△
			ZSP turns on 1) when the servo motor is decelerated to 50r/min, and ZSP turns off 2) when the servo motor is accelerated to 70r/min again. ZSP turns on 3) when the servo motor is decelerated again to 50r/min, and turns off 4) when the servo motor speed has reached -70r/min. The range from the point when the servo motor speed has reached ON level, and ZSP turns on, to the point when it is accelerated again and has reached OFF level is called hysteresis width. Hysteresis width is 20r/min for the MR-JN-A servo amplifier. If parameter No. PA04 is set to "□□1" and the overload tough drive function is enabled, the ZSP ON time in the overload tough drive is delayed. The delay time can be limited by parameter No. PC26.				
Electromagnetic brake interlock	MBR		MBR turns off when the servo is switched off or an alarm occurs. At an alarm occurrence, MBR turns off regardless of the base circuit status.	DO-1	○	○	○
Warning	WNG		When a warning occurs, WNG turns on. When there is no warning, WNG turns off approximately 1s after power-on.	DO-1	△	△	△
During tough drive	MTTR		If the instantaneous power failure tough drive function selection is enabled, MTTR turns on when the instantaneous tough drive activates. If parameter No. PD20 is set to "□1□□", MTTR also turns on when the overload tough drive activates.	DO-1	△	△	
During variable gain selection	CDPS		CDPS is on during gain changing.	DO-1	△	△	△

3. SIGNALS AND WIRING

(2) Input signals

Signal	Symbol	Connector pin No.	Functions/Applications	I/O division	Control mode		
					P	S	T
Forward rotation pulse train Reverse rotation pulse train	PP NP PG NG	CN1-23 CN1-25 CN1-22 CN1-24	Used to input command pulses. <ul style="list-style-type: none"> • In the open collector system (max. input frequency 200kpps) Forward rotation pulse train across PP-DOCOM Reverse rotation pulse train across NP-DOCOM • In the differential receiver system (max. input frequency 1Mpps) Forward rotation pulse train across PG-PP Reverse rotation pulse train across NG-NP The command input pulse form can be changed using parameter No. PA13.	DI-2	○		(Note)

Note. For the internal speed control mode or the internal torque control mode, PP or NP cannot be assigned to the CN1-23 pin or CN1-25 pin. When assigning an input device to the CN1-23 pin or CN1-25 pin, supply OPC with 24VDC (+) and use it at the sink interface. It cannot be used at the source interface.

(3) Output signals

Signal	Symbol	Connector pin No.	Functions/Applications	I/O division	Control mode		
					P	S	T
Encoder Z-phase pulse (Open collector)	OP	CN1-21	Outputs the zero-point signal of the encoder. One pulse is output per servo motor revolution. OP turns on when the zero-point position is reached. (Negative logic) The minimum pulse width is about 400μs. For home position return using this pulse, set the creep speed to 100r/min. or less.	DO-2	○	○	○
Encoder A-phase pulse (Differential line driver)	LA LAR	CN1-15 CN1-16	Outputs pulses per servo motor revolution set in parameter No. PA15 in the differential line driver system. In CCW rotation of the servo motor, the encoder B-phase pulse lags the encoder A-phase pulse by a phase angle of $\pi/2$.	DO-2	○	○	○
Encoder B-phase pulse (Differential line driver)	LB LBR	CN1-17 CN1-18	The relationships between rotation direction and phase difference of the A- and B-phase pulses can be changed using parameter No. PC13.				
Encoder Z-phase pulse (Differential line driver)	LZ LZR	CN1-19 CN1-20	The same signal as OP is output in the differential line driver system.	DO-2	○	○	○

(4) Power supply

Signal	Symbol	Connector pin No.	Functions/Applications	I/O division	Control mode		
					P	S	T
Digital I/F power supply input	DICOM	CN1-1	Used to input 24VDC (200mA) for I/O interface. The power supply capacity changes depending on the number of I/O interface points to be used. For a sink interface, connect the positive terminal of the 24VDC external power supply to DICOM. For a source interface, connect the negative terminal of the 24VDC external power supply to DICOM.		○	○	○
Open collector power input	OPC	CN1-2	When inputting a pulse train in the open collector system, supply this terminal with the positive (+) power of 24VDC.		○		
Digital I/F common	DOCOM	CN1-13	Common terminal for input signals such as SON and EM1. Pins are connected internally. Separated from LG. For a sink interface, connect the negative terminal of the 24VDC external power supply to DICOM. For a source interface, connect the positive terminal of the 24VDC external power supply to DICOM.		○	○	○
Control common	LG	CN1-14	Common terminal for OP.		○	○	○
Shield	SD	Plate	Connect the external conductor of the shield cable.		○	○	○

3. SIGNALS AND WIRING

3.6 Detailed description of the signals

POINT	<ul style="list-style-type: none"> For the positioning mode, refer to section 13.2.4.
-------	--

3.6.1 Position control mode

POINT	<ul style="list-style-type: none"> The noise immunity can be enhanced by setting parameter No. PA13 to "1 □ □" when the command pulse frequency is 500kpps or less or "2 □ □" when 200kpps or less. (Refer to section 4.1.11)
-------	--

(1) Pulse train input

(a) Input pulse waveform selection

Command pulses may be input in any of three different forms, for which positive or negative logic can be chosen. Set the command input pulse form in parameter No. PA13. Refer to section 4.1.11 for details.

(b) Connections and waveforms

1) Open collector system

Connect as shown below.

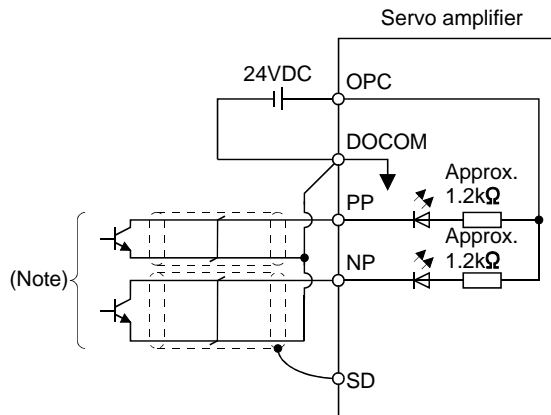

Note. Pulse train input interface is comprised of a photo coupler.

Therefore, it may be any malfunctions since the current is reduced when connect a resistance to a pulse train signal line.

The explanation assumes that the input waveform has been set to the negative logic and forward and reverse rotation pulse trains (parameter No. PA13 has been set to " □ 10 "). Their relationships with transistor ON/OFF are as follows.

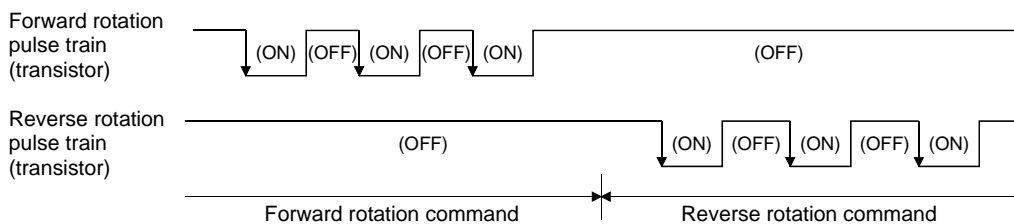

3. SIGNALS AND WIRING

2) Differential line driver system
Connect as shown below.

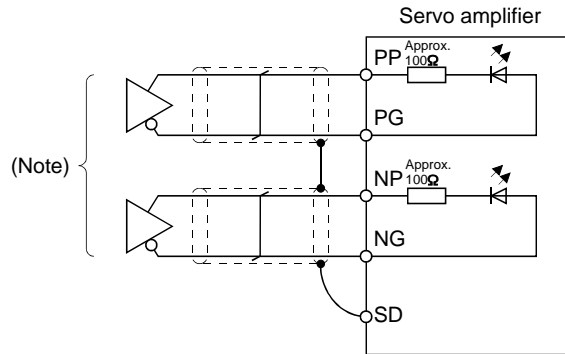

Note. Pulse train input interface is comprised of a photo coupler.
Therefore, it may be any malfunctions since the current is reduced when connect a resistance to a pulse train signal line.

The explanation assumes that the input waveform has been set to the negative logic and forward and reverse rotation pulse trains (parameter No. PA13 has been set to "□ 10").

The waveforms of PP, PG, NP and NG are based on that of the ground of the differential line driver.

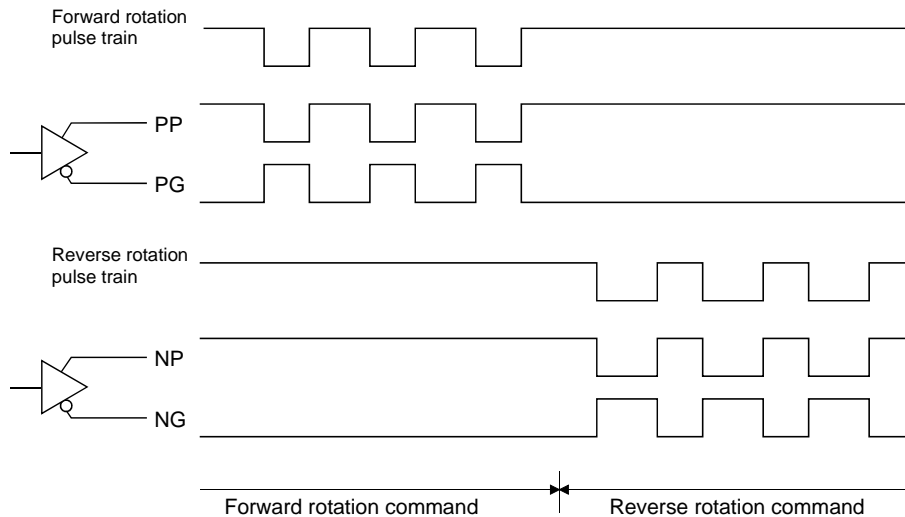

(2) In-position (INP)

INP turns on when the number of droop pulses in the deviation counter falls within the preset in-position range (parameter No. PA10). INP turns on when low-speed operation is performed with a large value set as the in-position range.

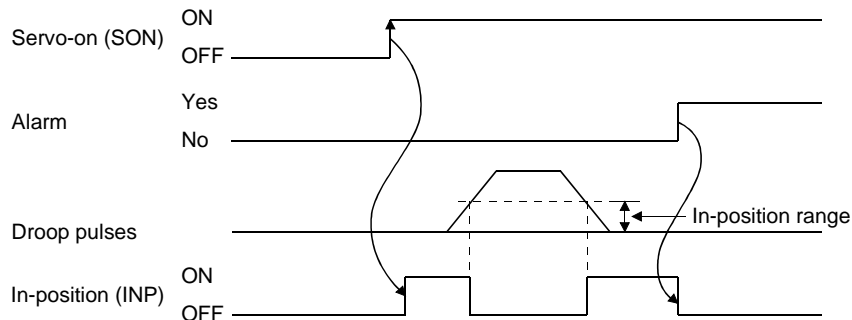

3. SIGNALS AND WIRING

(3) Ready (RD)

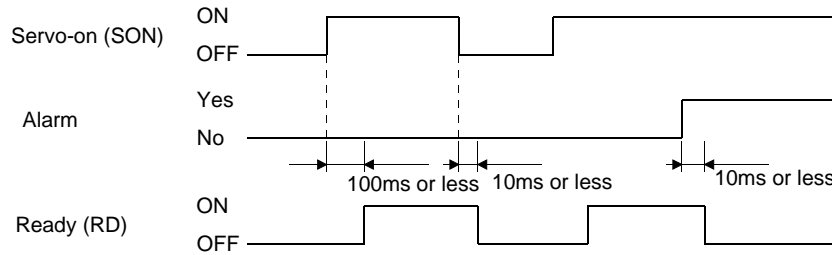

(4) Torque limit

CAUTION If the torque limit is canceled during servo lock, the servo motor may suddenly rotate according to position deviation in respect to the command position.

(a) Torque limit and torque

By setting parameter No. PA11 (forward torque limit) or parameter No. PA12 (reverse torque limit), torque is always limited to the maximum value during operation. A relationship between the limit value and servo motor torque is shown below.

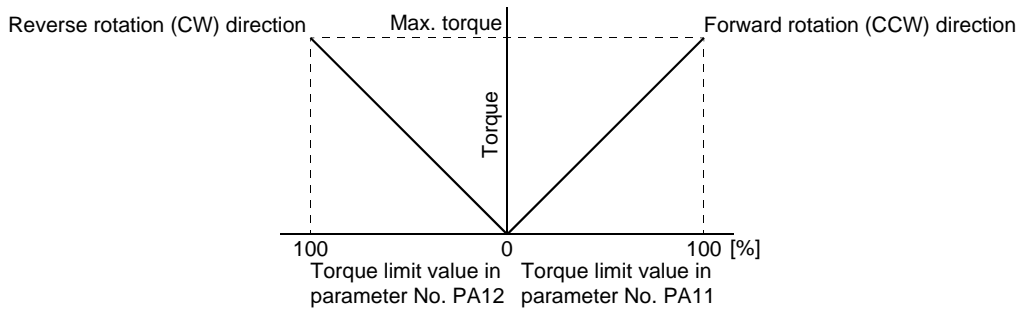

(b) Torque limit value selection

As shown below, the internal torque limit selection (TL1) can be used for selecting the torque limit between the forward torque limit (parameter No. PA11) or the reverse torque limit (parameter No. PA12) and the internal torque limit 2 (parameter No. PC14).

However, if the value of parameter No. PA11 or parameter No. PA12 is lower than the limit value selected by TL1, the value of parameter No. PA11 or parameter No. PA12 is made valid.

(Note) Input device	Limit value status	Validated torque limit values	
		Forward rotation (CCW) driving Reverse rotation (CW) regeneration	Reverse rotation (CW) driving Forward rotation (CCW) regeneration
0		Parameter No. PA11	Parameter No. PA12
1	Parameter No. PC14 > Parameter No. PA11 Parameter No. PA12	Parameter No. PA11	Parameter No. PA12
	Parameter No. PC14 < Parameter No. PA11 Parameter No. PA12	Parameter No. PC14	Parameter No. PC14

Note. 0: off
1: on

(c) Limiting torque (TLC)

TLC turns on when the servo motor torque reaches the torque limited by the forward torque limit, the reverse torque limit or the internal torque limit 2.

3. SIGNALS AND WIRING

3.6.2 Internal speed control mode

(1) Internal speed command settings

(a) Speed command and speed

The servo motor operates at the speed set in the parameters.

Up to 8 speeds can be set to the internal speed command.

The following table indicates the rotation direction according to forward rotation start (ST1) and reverse rotation start (ST2) combination.

(Note 1) Input device		(Note 2) Rotation direction
ST2	ST1	
0	0	Stop (Servo lock)
0	1	Forward rotation (CCW)
1	0	Reverse rotation (CW)
1	1	Stop (Servo lock)

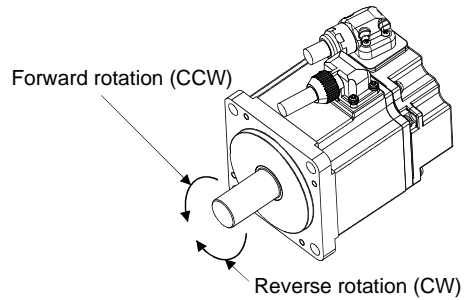

Note 1. 0: off

1: on

2. If the torque limit is canceled during servo lock, the servo motor may suddenly rotate according to position deviation in respect to the command position.

Connect the wirings as follows when operating in forward or reverse rotation with the internal speed command set to the eighth speed.

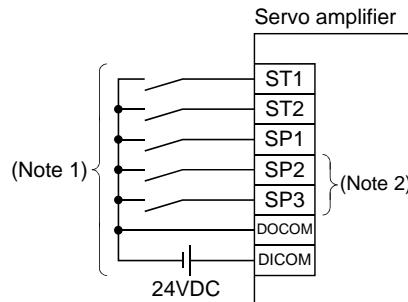

Note 1. For the sink I/O interface. For the source I/O interface, refer to section 3.8.3.

2. Set the input devices by parameter No. PD03 to PD14.

3. SIGNALS AND WIRING

POINT
<ul style="list-style-type: none"> ▪ The servo-on (SON) can be set to turn on automatically by parameter No. PD01 (input signal automatic ON selection 1). ▪ The forward rotation stroke end (LSP) and the reverse rotation stroke end (LSN) switches as follows: <ul style="list-style-type: none"> ▪ Assigned to the external input signals: depends on the value set in parameter No. PD01. ▪ Not assigned to the external input signals: automatically turns on regardless of the value set in parameter No. PD01. ▪ If parameter No. PC23 (function selection C-2) is set to " □ □ 0 " (initial value), the servo motor is servo-locked regardless of the deceleration time constant when the zero speed (ZSP) turns on.

(b) Speed selection 1 (SP1) and speed command value

At the initial condition, the speed command values for the internal speed command 0 and 1 can be selected using the speed selection 1 (SP1).

(Note) Input device		Speed command value
SP1		
0		Internal speed command 0 (parameter No. PC05)
1		Internal speed command 1 (parameter No. PC06)

Note. 0: off
1: on

By making the speed selection 2 (SP2) and the speed selection 3 (SP3) usable by setting of parameter No.PD03 to PD14, the speed command values for the internal speed commands 0 to 7 can be selected.

(Note) Input device			Speed command value
SP3	SP2	SP1	
0	0	0	Internal speed command 0 (parameter No. PC05)
0	0	1	Internal speed command 1 (parameter No. PC06)
0	1	0	Internal speed command 2 (parameter No. PC07)
0	1	1	Internal speed command 3 (parameter No. PC08)
1	0	0	Internal speed command 4 (parameter No. PC31)
1	0	1	Internal speed command 5 (parameter No. PC32)
1	1	0	Internal speed command 6 (parameter No. PC33)
1	1	1	Internal speed command 7 (parameter No. PC34)

Note. 0: off
1: on

The speed may be changed during rotation. In this case, the values set in parameters No. PC01 and PC02 are used for acceleration/deceleration.

When the speed has been specified under any internal speed command, it does not vary due to the ambient temperature.

3. SIGNALS AND WIRING

(2) Speed reached (SA)

SA turns on when the servo motor speed has nearly reached the speed set to the internal speed command.

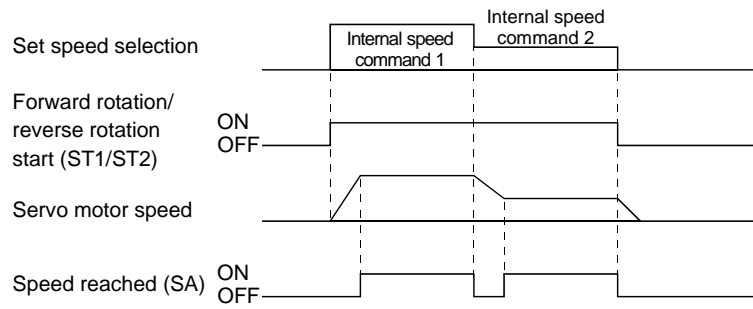

(3) Torque limit

As in section 3.6.1 (4).

3. SIGNALS AND WIRING

3.6.3 Internal torque control mode

(1) Internal torque command settings

Torque is controlled by the internal torque command set in parameter No. PC12.

If the internal torque command is small, the torque may vary when the actual speed reaches the speed limit value. In such case, increase the speed limit value.

The following table indicates the torque generation directions determined by the forward rotation selection (RS1) and the reverse rotation selection (RS2) when the internal torque command (parameter No. PC12) is used.

(Note) Input device		Rotation direction	
RS2	RS1	Internal torque command (parameter No. PC12)	
		0.1 to 100.0%	0.0%
0	0	Torque is not generated.	
0	1	CCW (reverse rotation in driving mode/forward rotation in regenerative mode)	
1	0	CW (forward rotation in driving mode/reverse rotation in regenerative mode)	
1	1	Torque is not generated.	

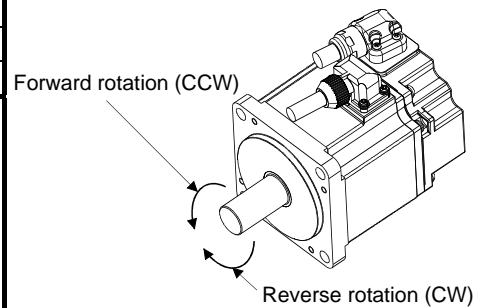

Note. 0: off
1: on

Generally, make connection as shown below.

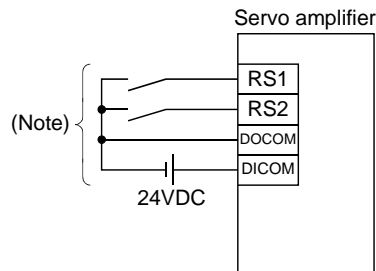

Note. For the sink I/O interface. For the source I/O interface, refer to section 3.8.3.

The following shows the effect of the low-pass filter on the internal torque command.

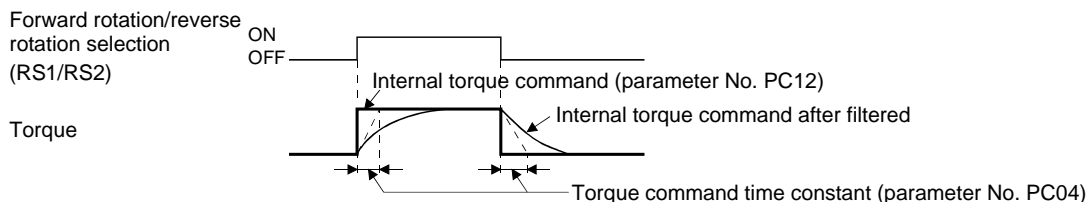

(2) Torque limit

By setting parameter No. PA11 (forward torque limit) or parameter No. PA12 (reverse torque limit), torque is always limited to the maximum value during operation. A relationship between limit value and servo motor torque is as in section 3.6.1 (4).

3. SIGNALS AND WIRING

(3) Speed limit

(a) Speed limit value and speed

The speed is limited to the values set in parameters No. PC05 to PC08 and PC31 to PC34 (Internal speed limit 0 to 7).

When the servo motor speed reaches the speed limit value, the internal torque control may become unstable. Make the set value more than 100r/min greater than the desired speed limit value.

The following table indicates the limit direction according to forward rotation selection (RS1) and reverse rotation selection (RS2) combination.

(Note) Input device		Speed limit direction
RS1	RS2	
1	0	Forward rotation (CCW)
0	1	Reverse rotation (CW)

Note. 0: off
1: on

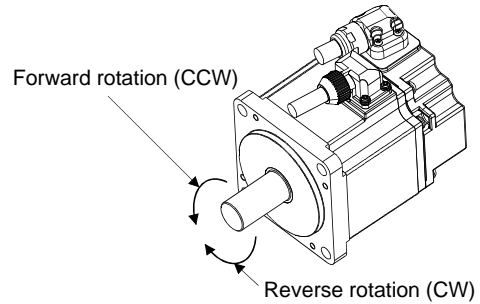

Connect the wirings as follows when setting the internal speed limit to the eighth speed.

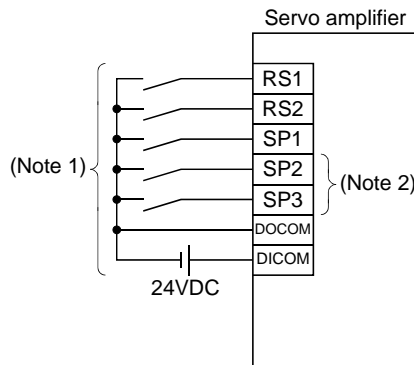

Note 1. For the sink I/O interface. For the source I/O interface, refer to section 3.8.3.
2. Set the input devices by parameter No. PD03 to PD14.

POINT
<ul style="list-style-type: none"> The servo-on (SON), the forward rotation stroke end (LSP), and the reverse rotation stroke end (LSN) can be set to turn on automatically by parameter No. PD01 (input signal automatic ON selection 1).

3. SIGNALS AND WIRING

(b) Speed selection 1 (SP1) and speed limit values

At the initial condition, the speed limit values for the internal speed limits 0 and 1 can be selected using the speed selection 1 (SP1).

(Note) Input device	Speed limit value
SP1	
0	Internal speed limit 0 (parameter No. PC05)
1	Internal speed limit 1 (parameter No. PC06)

Note. 0: off
1: on

By making the speed selection 2 (SP2) and the speed selection 3 (SP3) usable by setting parameter No.PD03 to PD14, the speed limit values for the internal speed commands 0 to 7 can be selected.

(Note) Input device			Speed limit value
SP3	SP2	SP1	
0	0	0	Internal speed limit 0 (parameter No. PC05)
0	0	1	Internal speed limit 1 (parameter No. PC06)
0	1	0	Internal speed limit 2 (parameter No. PC07)
0	1	1	Internal speed limit 3 (parameter No. PC08)
1	0	0	Internal speed limit 4 (parameter No. PC31)
1	0	1	Internal speed limit 5 (parameter No. PC32)
1	1	0	Internal speed limit 6 (parameter No. PC33)
1	1	1	Internal speed limit 7 (parameter No. PC34)

Note. 0: off
1: on

When the speed is limited by the internal speed limits 0 to 7, the speed does not vary with the ambient temperature.

(c) Limiting speed (VLC)

VLC turns on when the servo motor speed reaches the speed limited by the internal speed limits 0 to 7.

3. SIGNALS AND WIRING

3.6.4 Position/speed control change mode

Set parameter No. PA01 to " □ □ 1 " to switch to the position/internal speed control change mode.

(1) Control change (LOP)

By using the control change (LOP), control mode can be switched between the position control and the internal speed control modes from an external contact. Relationships between LOP and control modes are indicated below.

(Note) LOP	Control mode
0	Position control mode
1	Internal speed control mode

Note. 0: off
1: on

The control mode may be switched in the zero speed status. To ensure safety, switch the control mode after the servo motor has stopped. When the control mode is switched to the internal speed control mode from the position control mode, droop pulses are cleared.

Even if the speed is decreased to the zero speed or below after switching LOP, the control mode cannot be switched. A change timing chart is shown below.

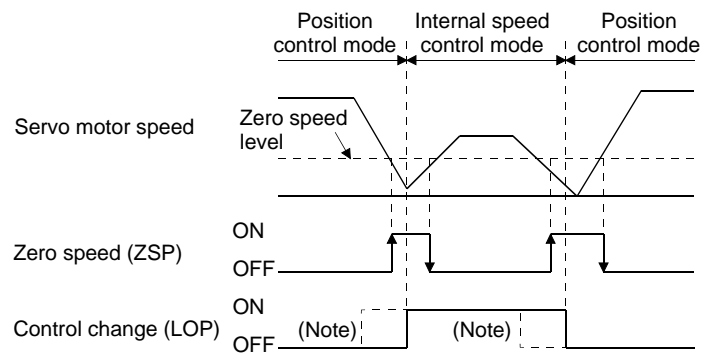

Note. When ZSP is not on, control cannot be changed if LOP is switched on-off.
If ZSP switches on after that, control cannot be changed.

(2) Torque limit in position control mode

As in section 3.6.1 (4).

(3) Speed setting in internal speed control mode

As in section 3.6.2 (1).

(4) Speed reached (SA)

As in section 3.6.2 (2).

3. SIGNALS AND WIRING

3.6.5 Internal speed/internal torque control change mode

Set No. PA01 to " □□ 3 " to switch to the internal speed/internal torque control change mode.

(1) Control change (LOP)

By using the control change (LOP), the control mode can be switched between the internal speed control and the internal torque control mode from an external contact. Relationships between LOP and control modes are indicated below.

(Note) LOP	Servo control mode
0	Internal speed control mode
1	Internal torque control mode

Note. 0: off
1: on

The control mode may be changed at any time. A change timing chart is shown below.

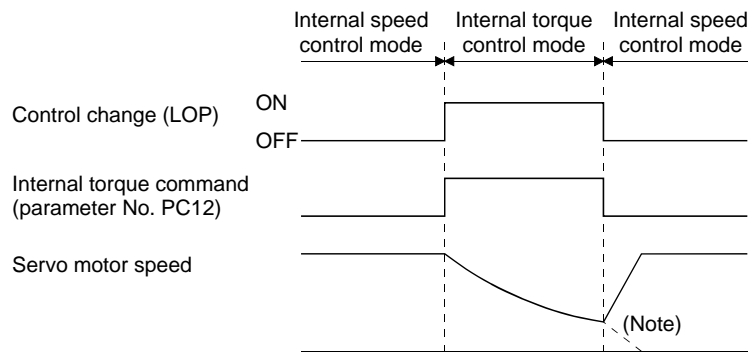

Note. When the start (ST1, ST2) is switched off as soon as the mode is changed to internal speed control, the servo motor comes to a stop according to the deceleration time constant.

(2) Speed setting in internal speed control mode

As in section 3.6.2 (1).

(3) Torque limit in internal speed control mode

As in section 3.6.1 (4).

(4) Speed limit in internal torque control mode

As in section 3.6.3 (3).

(5) Internal torque control setting in internal torque control mode

As in section 3.6.3 (1).

(6) Torque limit in internal torque control mode

As in section 3.6.3 (2).

3. SIGNALS AND WIRING

3.6.6 Internal torque/position control change mode

Set parameter No. PA01 to "□□5" to switch to the internal torque/position control change mode.

(1) Control change (LOP)

By using the control change (LOP), the control mode can be switched between the internal torque control and the position control modes from an external contact. Relationships between LOP and control modes are indicated below.

(Note) LOP	Servo control mode
0	Internal torque control mode
1	Position control mode

Note. 0: off
1: on

The control mode may be switched in the zero speed status.

To ensure safety, switch the control mode after the servo motor has stopped. When the control mode is switched to the internal torque control mode from the position control mode, droop pulses are cleared.

Even if the speed is decreased to the zero speed or below after switching LOP, the control mode cannot be switched. A change timing chart is shown below.

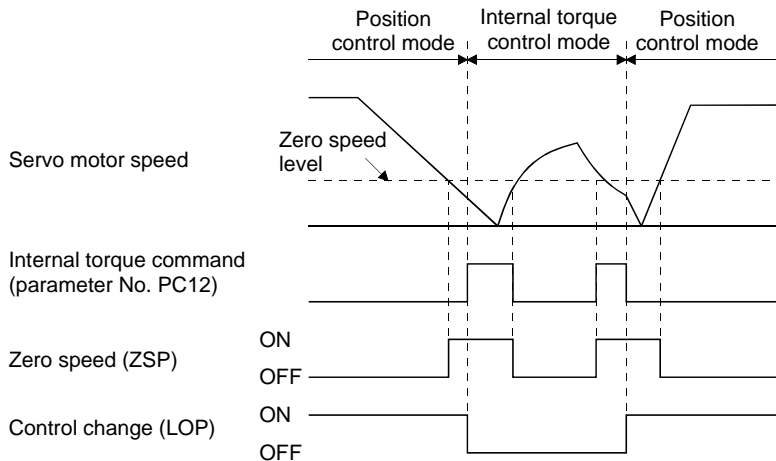

(2) Speed limit in internal torque control mode

As in section 3.6.3 (3).

(3) Internal torque control setting in internal torque control mode

As in section 3.6.3 (1).

(4) Torque limit in internal torque control mode

As in section 3.6.3 (2).

(5) Torque limit in position control mode

As in section 3.6.1 (4).

3. SIGNALS AND WIRING

3.7 Alarm occurrence timing chart

 CAUTION	<ul style="list-style-type: none"> When an alarm has occurred, remove its cause, make sure that the operation signal is not being input, ensure safety, and reset the alarm before restarting operation. As soon as an alarm occurs, turn off servo-on (SON) and power off.
--	---

When an alarm occurs in the servo amplifier, the base circuit is shut off and the servo motor is coasted to a stop. Switch off the main circuit power supply in the external sequence. To reset the alarm, switch the control circuit power supply from off to on, press the " SET " button on the current alarm screen, or turn the reset (RES) from off to on. However, the alarm cannot be reset unless its cause is removed.

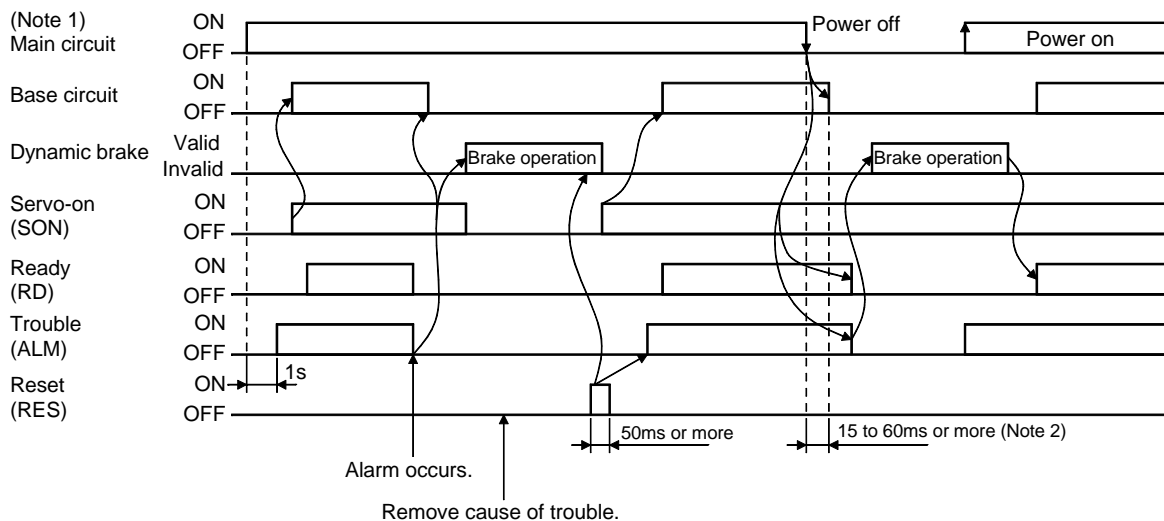

Note 1. Shut off the main circuit power as soon as an alarm occurs.

2. Changes depending on the operating status.

(1) Overcurrent, overload 1 or overload 2

If operation is repeated by switching control circuit power off, then on to reset the overcurrent (32. □), overload 1 (50. □) or overload 2 (51. □) alarm after its occurrence, without removing its cause, the servo amplifier and servo motor may become faulty due to temperature rise. Securely remove the cause of the alarm and also allow about 30 minutes for cooling before resuming operation.

(2) Regenerative alarm

If operation is repeated by switching control circuit power off, then on to reset the regenerative (30. □) alarm after its occurrence, the regenerative resistor will generate heat, resulting in an accident.

(3) Instantaneous power failure

If power failure has occurred in the control circuit power supply, undervoltage (10.1) occurs when the power is recovered.

(4) In-position control mode

Once an alarm occurs, the servo motor command rejects the command pulse. When resuming the operation after resetting the alarm, make a home position return.

3. SIGNALS AND WIRING

3.8 Interfaces

3.8.1 Internal connection diagram

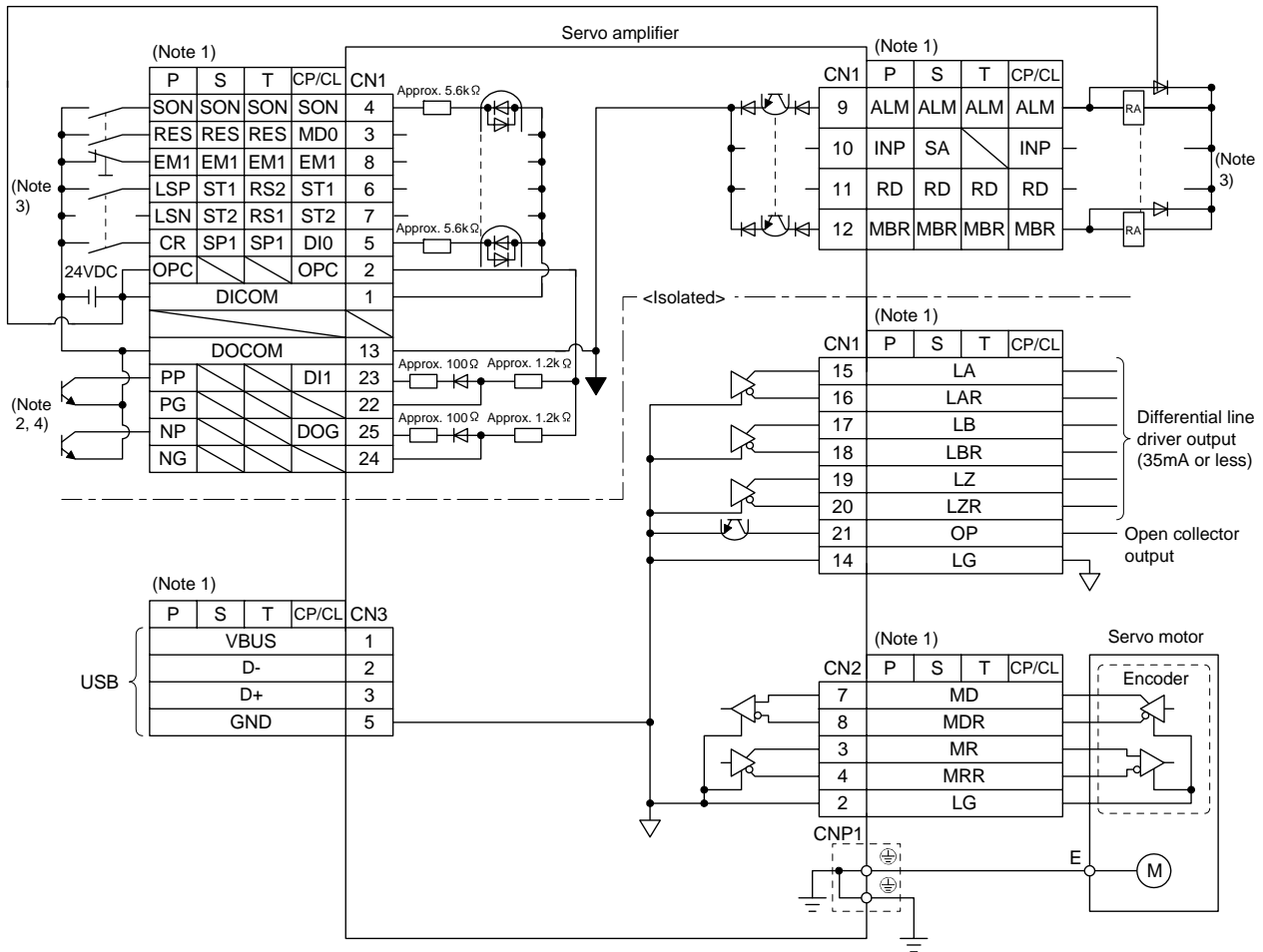

Note 1. P: Position control mode, S: Internal speed control mode, T: Internal torque control mode
 CP: Positioning mode (Point table method) CL: Positioning mode (Program method)

2. This diagram is for the open collector pulse train input. When inputting the differential line driver pulse train in the position control mode, make the following connection.

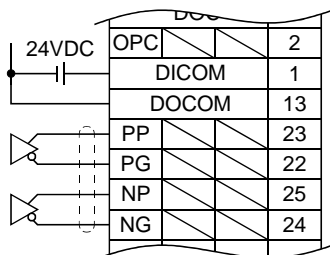

3. For the sink I/O interface. For the source I/O interface, refer to section 3.8.3.

4. When assigning the input device to the CN1-23 pin or CN1-25 pin in the internal speed control mode, internal torque control mode, or positioning mode, use it at the sink input interface. It cannot be used at the source input interface. For the positioning mode, the input devices (DI1, DOG) are assigned to the initial values.

3. SIGNALS AND WIRING

3.8.2 Detailed description of interfaces

This section provides the details of the I/O signal interfaces (refer to the I/O division in the table) given in section 3.5. Refer to this section and make connection with the external equipment.

(1) Digital input interface DI-1

Give a signal with a relay or open collector transistor. The following figure is for the sink input. Refer to section 3.8.3 for the source input.

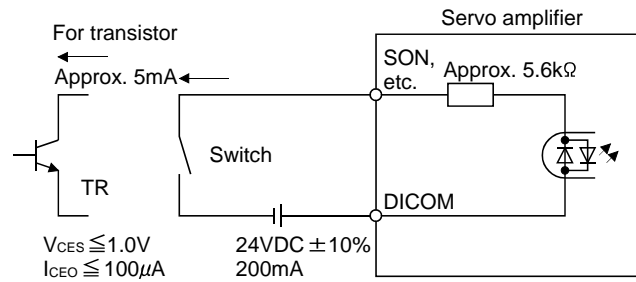

(2) Digital output interface DO-1

A lamp, relay or photocoupler can be driven. Install a diode (D) for an inductive load, or install an inrush current suppressing resistor (R) for a lamp load. (Rated current: 40mA or less, maximum current: 50mA or less, inrush current: 100mA or less) A maximum of 2.6V voltage drop occurs in the servo amplifier. The following figure is for the sink output. Refer to section 3.8.3 for the source output.

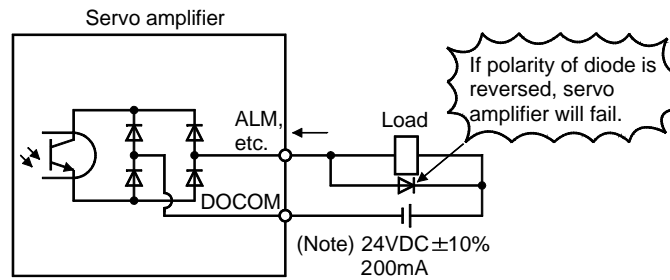

Note. If the voltage drop (maximum of 2.6V) interferes with the relay operation, apply high voltage (up to 26.4V) from external source.

3. SIGNALS AND WIRING

(3) Pulse train input interface DI-2

Give a pulse train signal in the open collector system or differential line driver system.

(a) Open collector system

1) Interface

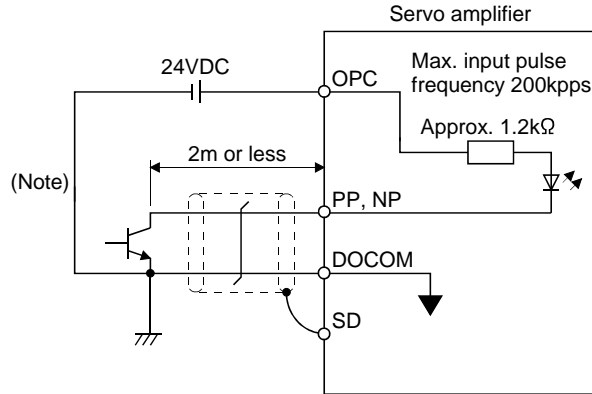

Note. Pulse train input interface is comprised of a photo coupler.

Therefore, it may be any malfunctions since the current is reduced when connect a resistance to a pulse train signal line.

2) Input pulse condition

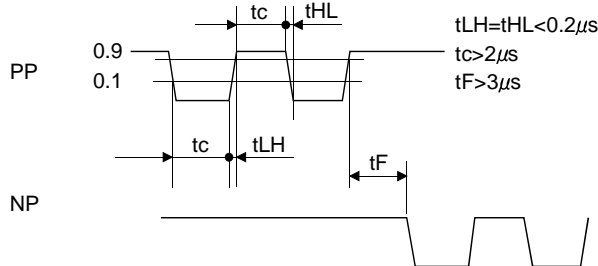

(b) Differential line driver system

1) Interface

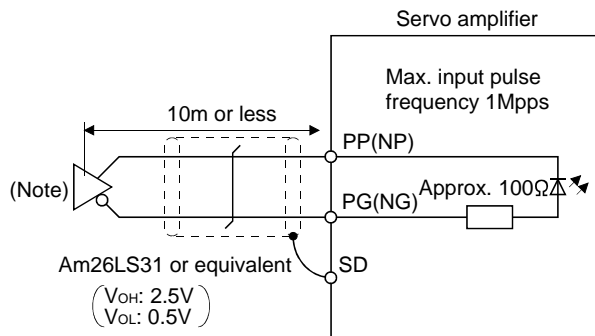

Note. Pulse train input interface is comprised of a photo coupler.

Therefore, it may be any malfunctions since the current is reduced when connect a resistance to a pulse train signal line.

3. SIGNALS AND WIRING

2) Input pulse condition

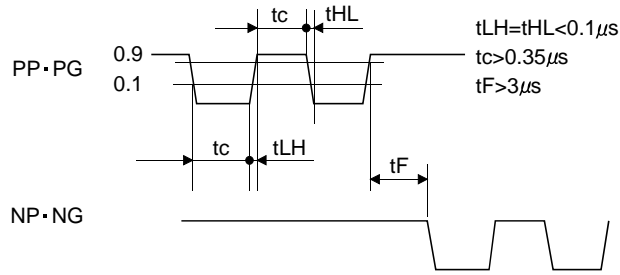

(4) Encoder output pulse DO-2

(a) Open collector system

Interface

Max. output current: 35mA

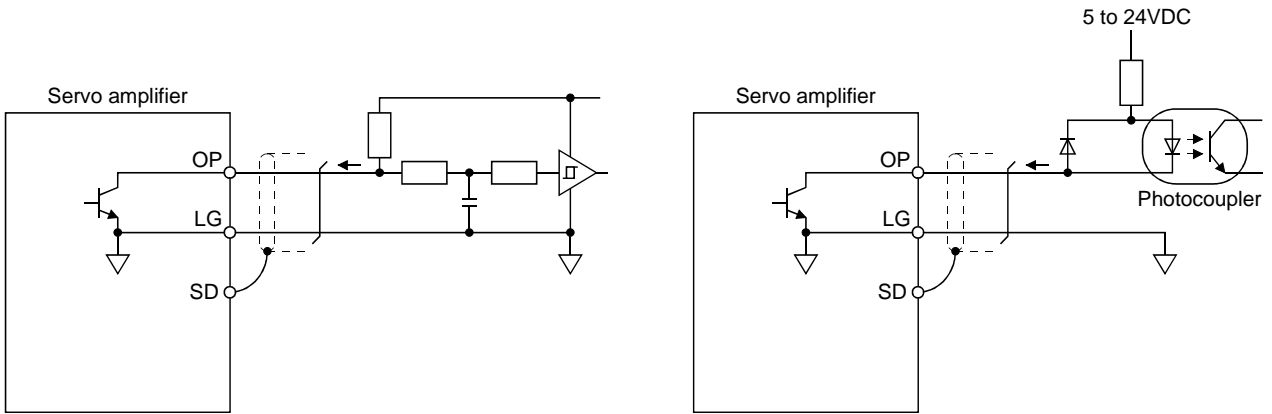

(b) Differential line driver system

1) Interface

Max. output current: 35mA

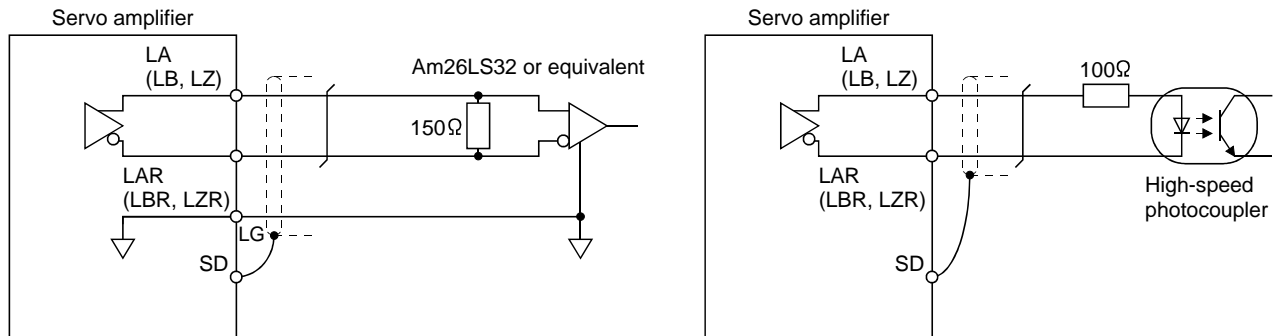

3. SIGNALS AND WIRING

2) Output pulse

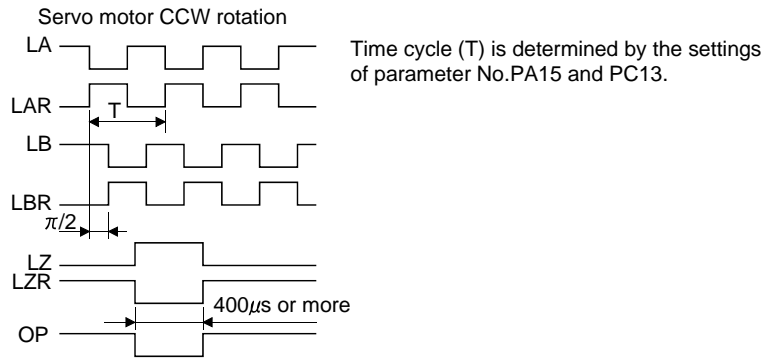

3.8.3 Source I/O interfaces

In this servo amplifier, source type I/O interfaces can be used. In this case, all DI-1 input signals and DO-1 output signals are of source type. Perform wiring according to the following interfaces.

(1) Digital input interface DI-1

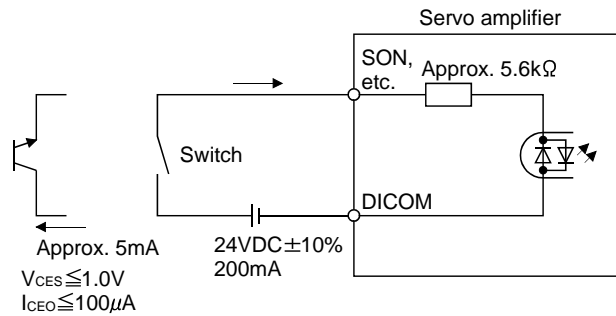

(2) Digital output interface DO-1

A maximum of 2.6V voltage drop occurs in the servo amplifier.

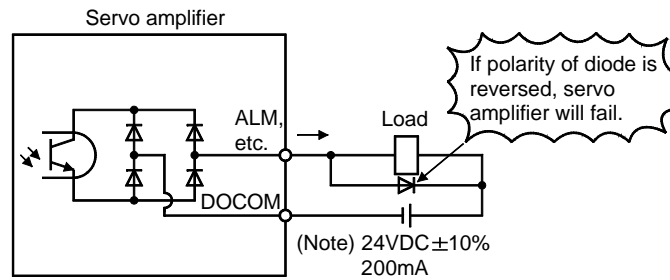

Note. If the voltage drop (maximum of 2.6V) interferes with the relay operation, apply high voltage (up to 26.4V) from external source.

3. SIGNALS AND WIRING

3.9 Treatment of cable shield external conductor

In the case of the CN1 and CN2 connectors, securely connect the shielded external conductor of the cable to the ground plate as shown in this section and fix it to the connector shell.

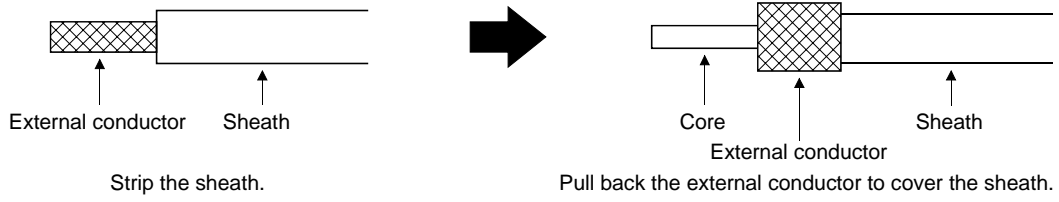

(1) For CN1 connector (3M connector)

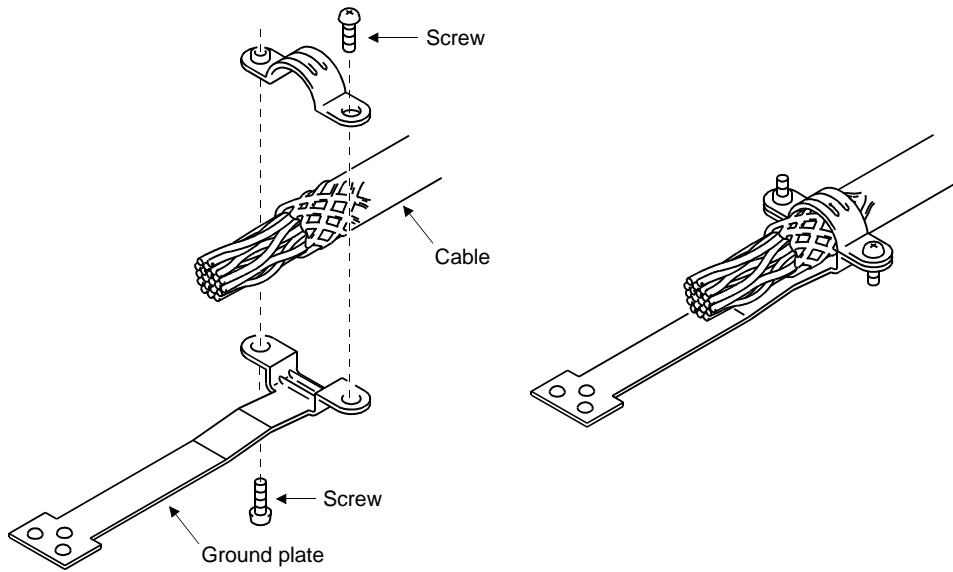

(2) For CN2 connector (3M or Molex connector)

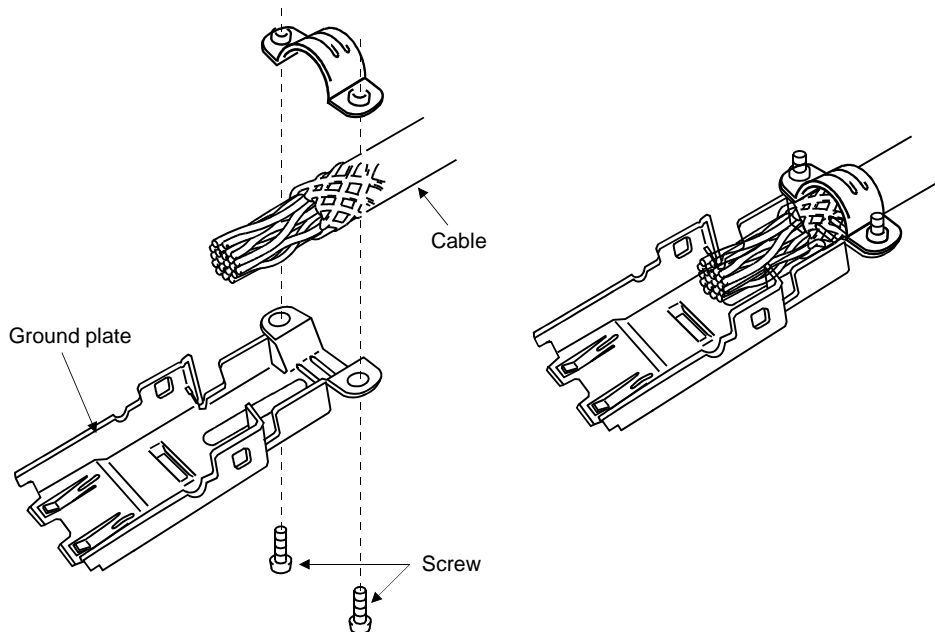

3. SIGNALS AND WIRING

3.10 Connection of servo amplifier and servo motor



CAUTION

- During power-on, do not open or close the motor power line. Otherwise, an abnormal operation or malfunction may occur.

3.10.1 Connection instructions



WARNING

- Insulate the connections of the power supply terminals to prevent an electric shock.



CAUTION

- Connect the wires to the correct phase terminals (U, V, W) of the servo amplifier and servo motor. Not doing so may cause unexpected operation.
- Do not connect AC power supply directly to the servo motor. Otherwise, a fault may occur.
- Do not use the 24VDC interface and control circuit power supplies for the electromagnetic brake. Always use the power supply designed exclusively for the electromagnetic brake. Otherwise, a fault may occur.

POINT

- Refer to section 11.1 for the selection of the encoder cable.

This section indicates the connection of the servo motor power supply (U, V, W). Use of the optional cable or the connector set is recommended for connection between the servo amplifier and the servo motor. Refer to section 11.1 for details of the options.

For grounding, connect the earth cable of the servo motor to the protective earth (PE) terminal of the servo amplifier and connect the ground cable of the servo amplifier to the earth via the protective earth of the control box.

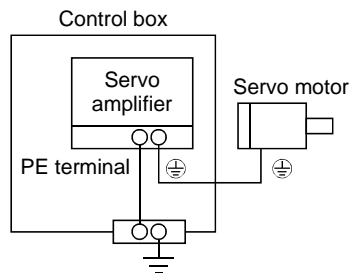

3. SIGNALS AND WIRING

3.10.2 Power supply cable wiring diagrams

(1) HF-KN series · HF-KP □ G1/G5/G7 series servo motor

(a) When cable length is 10m or less

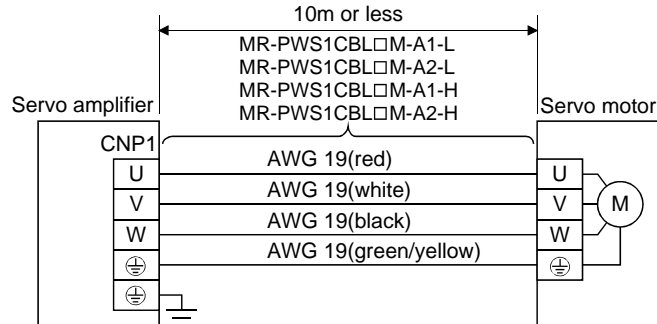

(b) When cable length exceeds 10m

When the cable length exceeds 10m, fabricate an extension cable as shown below. In this case, the motor power supply cable should be within 2m long.

Refer to section 11.5 for the wire used for the extension cable.

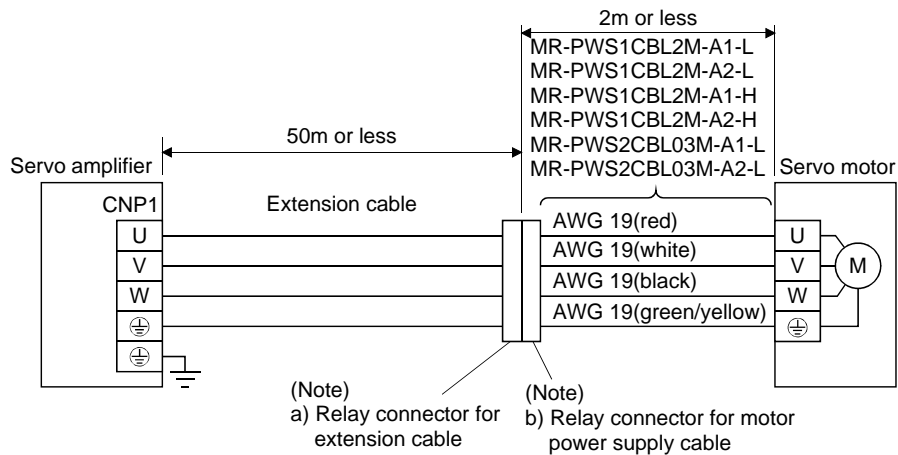

Note. Use of the following connectors is recommended when ingress protection (IP65) is necessary.

Relay connector	Description	IP rating
a) Relay connector for extension cable	Connector: RM15WTPZ-4P(71) Cord clamp: RM15WTP-CP(5)(71) (Hirose Electric) └ Numeral changes depending on the cable OD.	IP65
b) Relay connector for motor power supply cable	Connector: RM15WTJA-4S(71) Cord clamp: RM15WTP-CP(8)(71) (Hirose Electric) └ Numeral changes depending on the cable OD.	IP65

3. SIGNALS AND WIRING

3.11 Servo motor with an electromagnetic brake

3.11.1 Safety precautions

- Configure an electromagnetic brake operation circuit which interlocks with an external emergency stop switch.

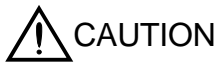

Contacts must be open when the servo-on, the trouble (ALM) or the electromagnetic brake interlock (MBR) signal turns off.

Circuit must be opened with the emergency stop switch.

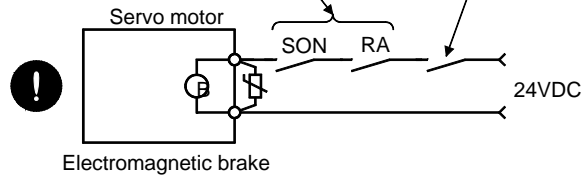

- The electromagnetic brake is provided for holding purpose and must not be used for ordinary braking.
- Before performing the operation, be sure to confirm that the electromagnetic brake operates properly.
- Do not use the 24VDC interface and control circuit power supplies for the electromagnetic brake. Always use the power supply designed exclusively for the electromagnetic brake. Otherwise, a fault may occur.

POINT

- Refer to chapter 12 for specifications such as the power supply capacity and operation delay time of the electromagnetic brake.
- Switch off the servo-on (SON) after the servo motor has stopped.
- Refer to (3) in section 12.1.3 for the selection of the surge absorbers for the electromagnetic brake.

Note the following when the servo motor with an electromagnetic brake is used.

- 1) Always assign the electromagnetic brake interlock (MBR) to CN1-12 pin by parameter No. PD18. (MBR is assigned to CN1-12 pin by default.)
- 2) The electromagnetic brake operates when the power (24VDC) turns off.
- 3) While the reset (RES) is on, the base circuit is shut off. When using the servo motor with a vertical shaft, use the electromagnetic brake interlock (MBR).

3.11.2 Setting

- (1) Set " □□ 05 " to parameter No. PD18 to assign the electromagnetic brake interlock (MBR) to CN1-12 pin.
- (2) Using parameter No. PC09 (electromagnetic brake sequence output), set a time delay (T_b) at servo-off from electromagnetic brake operation to base circuit shut-off as in the timing chart shown in section 3.11.3 (1).

3. SIGNALS AND WIRING

3.11.3 Timing charts

(1) Servo-on (SON) command (from controller) ON/OFF

Tb [ms] after the servo-on (SON) signal is switched off, the servo lock is released and the servo motor coasts. If the electromagnetic brake is made valid in the servo lock status, the brake life may be shorter. Therefore, when using the electromagnetic brake in a vertical lift application or the like, set Tb to about the same as the electromagnetic brake operation delay time to prevent a drop.

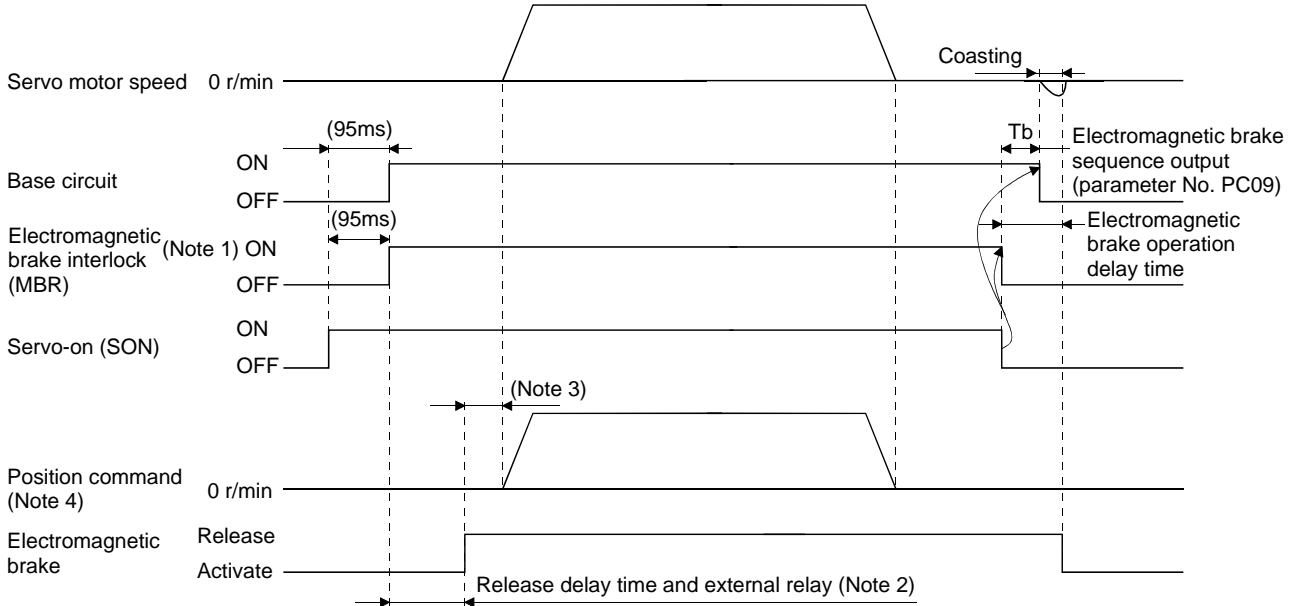

Note 1. ON: Electromagnetic brake is not activated.

OFF: Electromagnetic brake is activated.

2. Electromagnetic brake is released after delaying for the release delay time of electromagnetic brake and operation time of external circuit relay. For the release delay time of electromagnetic brake, refer to section 12.5.3, 12.6.3.

3. Give a position command after the electromagnetic brake is released.

4. For the position control mode.

(2) Forced stop (EM1) ON/OFF

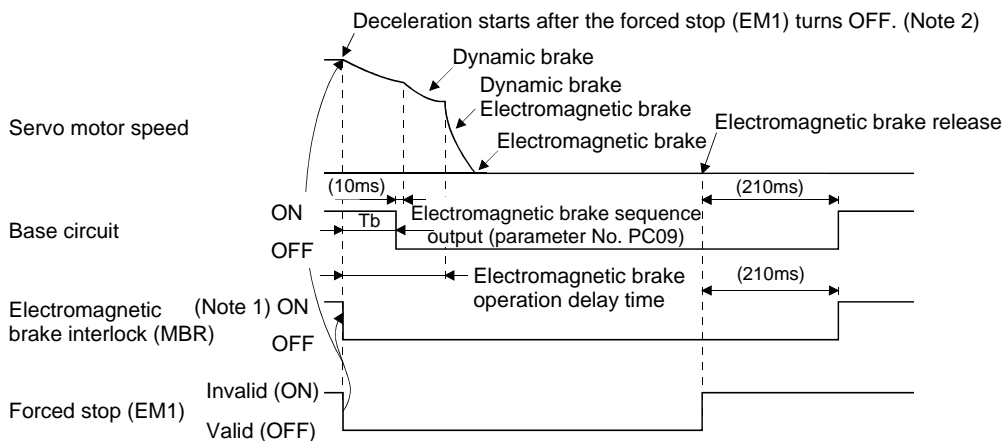

Note 1. ON: Electromagnetic brake is not activated.

OFF: Electromagnetic brake is activated.

2. The operation differs from the timing chart of MR-J3-□A servo amplifier.

3. SIGNALS AND WIRING

(3) Alarm occurrence

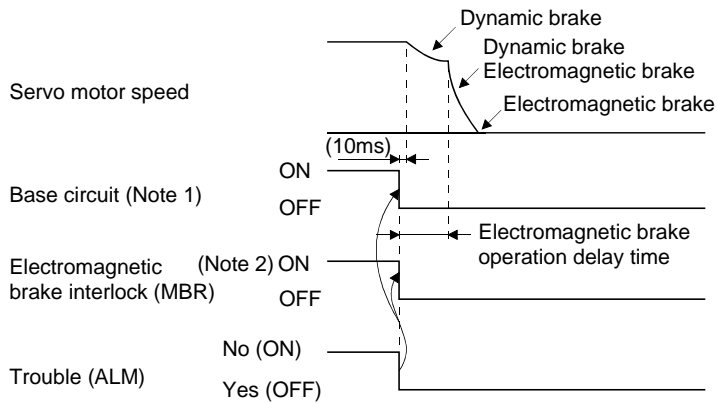

Note 1. Electromagnetic brake sequence output (parameter No. PC09) is invalid.

2. ON: Electromagnetic brake is not activated.

OFF: Electromagnetic brake is activated.

(4) Both main and control circuit power supplies off

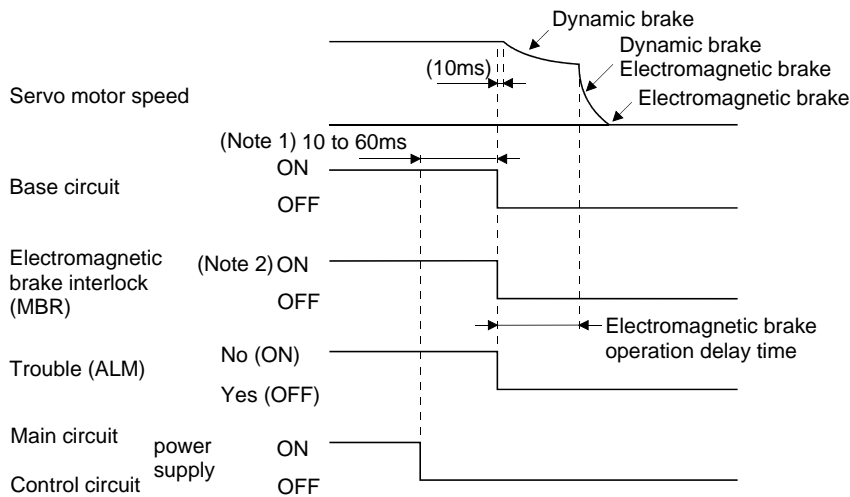

Note 1. Changes with the operating status.

2. ON: Electromagnetic brake is not activated.

OFF: Electromagnetic brake is activated.

3. SIGNALS AND WIRING

(5) Only main circuit power supply off (control circuit power supply remains on)

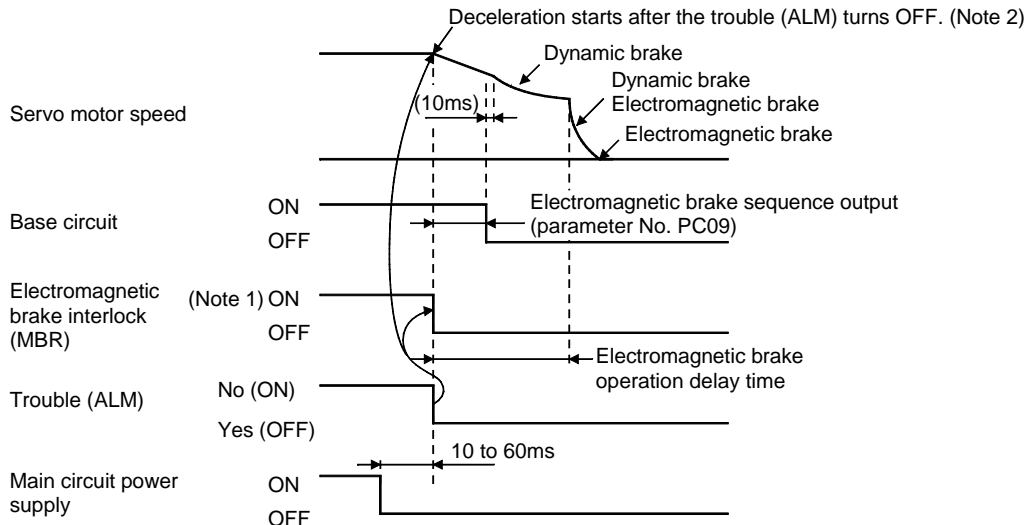

Note 1. ON: Electromagnetic brake is not activated.

OFF: Electromagnetic brake is activated.

2. The operation differs from the timing chart of MR-J3-□A servo amplifier.

3.11.4 Wiring diagrams (HF-KN series • HF-KP□G1/G5/G7 series servo motor)

(1) When cable length is 10m or less

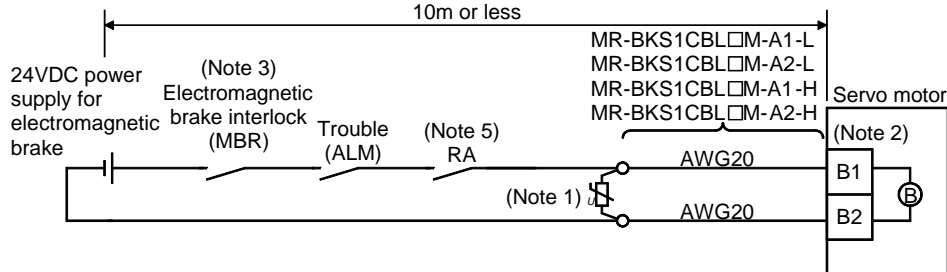

Note 1. Connect a surge absorber as close to the servo motor as possible.

2. There is no polarity in electromagnetic brake terminals (B1 and B2).

3. When using a servo motor with an electromagnetic brake, always assign the electromagnetic brake interlock (MBR) to CN1-12 pin by parameter No. PD18.

4. Do not use the 24VDC interface power supply for the electromagnetic brake.

5. Switch off the circuit interlocking with the emergency stop switch.

When fabricating the motor brake cable MR-BKS1CBL□M-H, refer to section 11.1.4.

3. SIGNALS AND WIRING

(2) When cable length exceeds 10m

When the cable length exceeds 10m, fabricate an extension cable as shown below on the customer side. In this case, the motor brake cable should be within 2m long.

Refer to section 11.5 for the wire used for the extension cable.

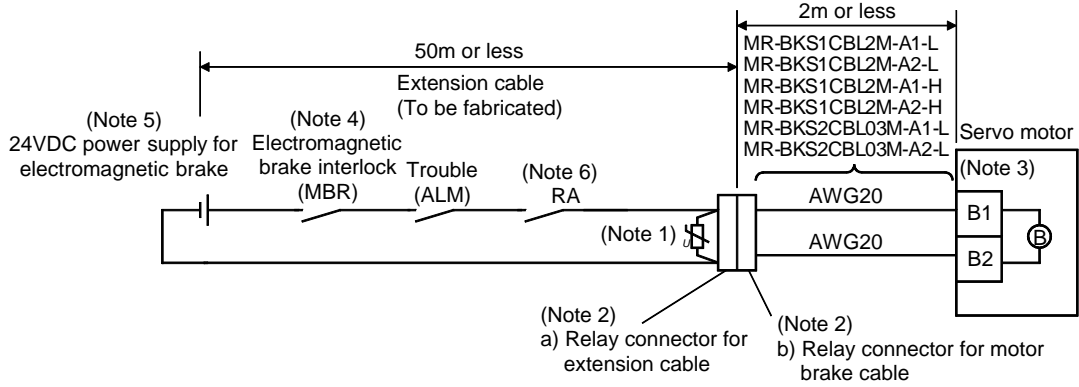

Note 1. Connect a surge absorber as close to the servo motor as possible.

2. Use of the following connectors is recommended when ingress protection (IP65) is necessary.

Relay connector	Description	IP rating
a) Relay connector for extension cable	CM10-CR2P-* (DDK) └ Wire size: S, M, L	IP65
b) Relay connector for motor brake cable	CM10-SP2S-* (DDK) └ Wire size: S, M, L	IP65

3. There is no polarity in electromagnetic brake terminals (B1 and B2).
4. When using a servo motor with an electromagnetic brake, always assign the electromagnetic brake interlock (MBR) to CN1-12 pin by parameter No. PD18.
5. Do not use the 24VDC interface power supply for the electromagnetic brake.
6. Switch off the circuit interlocking with the emergency stop switch.

3. SIGNALS AND WIRING

3.12 Grounding



WARNING

- Ground the servo amplifier and servo motor securely.
- To prevent an electric shock, always connect the protective earth (PE) terminal (terminal marked ⊕) of the servo amplifier with the protective earth (PE) of the control box.

The servo amplifier switches the power transistor on-off to supply power to the servo motor. Depending on the wiring and ground cable routing, the servo amplifier may be affected by the switching noise (due to di/dt and dv/dt) of the transistor. To prevent such a fault, refer to the following diagram and always ground. To conform to the EMC Directive, refer to the EMC Installation Guidelines (IB(NA)67310).

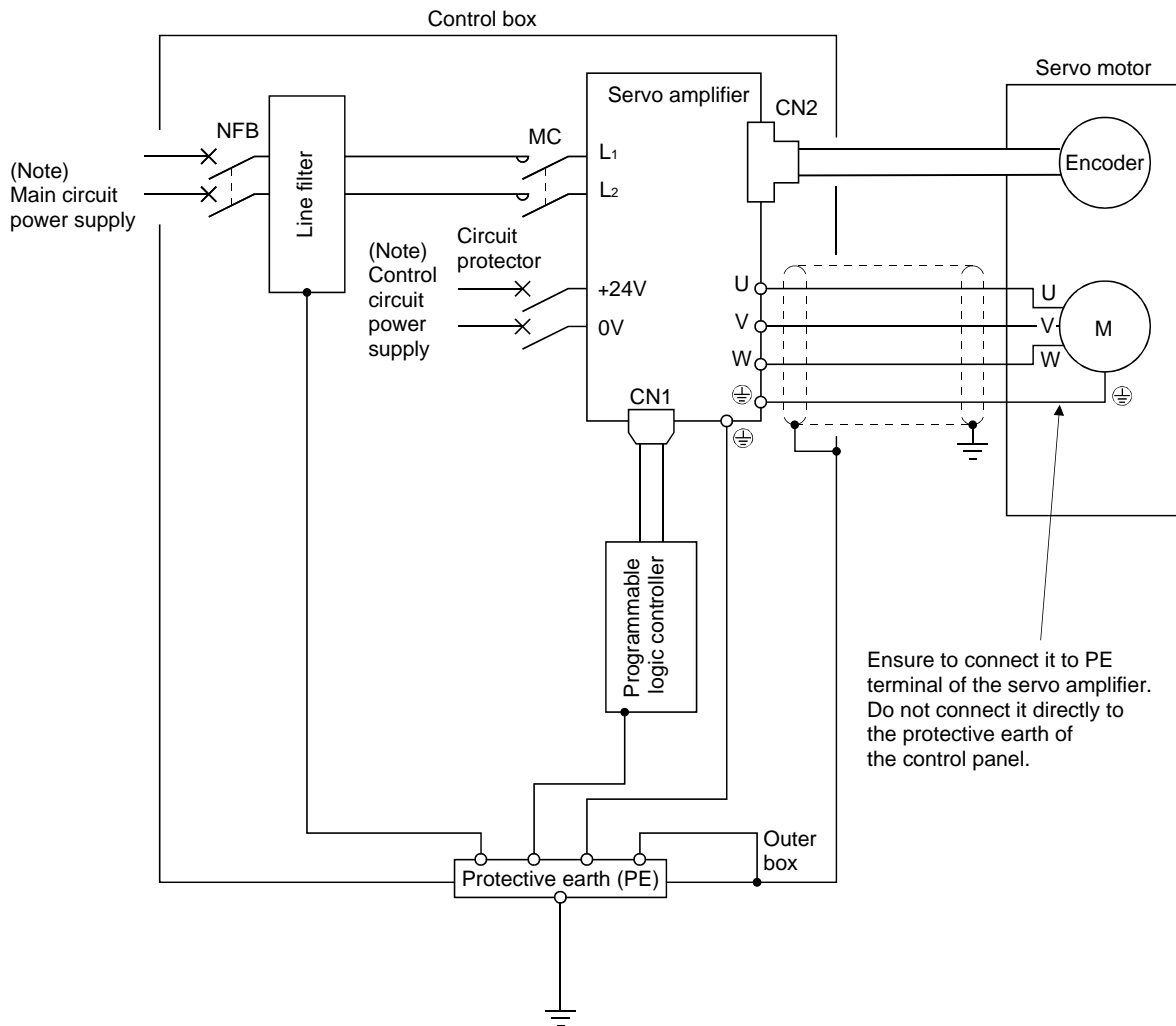

Note. For the specification of power supply, refer to section 1.3.

4. PARAMETERS

4. PARAMETERS



CAUTION

- Never adjust or change the parameter values extremely as it will make operation instable.
- If a fixed value is indicated in a digit of a parameter, do not change the fixed value.

POINT

- For the positioning mode, refer to section 13.7.
Positioning mode is supported by servo amplifier with software version B0 or later.

In this servo amplifier, the parameters are classified into the following groups on a function basis.

Parameter group	Main description
Basic setting parameters (No. PA□□)	Make basic setting with these parameters when using this servo amplifier in the position control mode.
Gain/filter parameters (No. PB□□)	Use these parameters when making gain adjustment manually.
Extension setting parameters (No. PC□□)	Use these parameters mainly when using this servo amplifier in the internal speed control mode or in the internal torque control mode.
I/O setting parameters (No. PD□□)	Use these parameters when changing the I/O signals of the servo amplifier.
Positioning setting parameters (No. PE□□)	Use these parameters only for the positioning mode. (Refer to section 13.7.5.)

When using this servo in the position control mode, mainly setting the basic setting parameters (No. PA□□) allows the setting of the basic parameters at the time of introduction.

4. PARAMETERS

4.1 Basic setting parameters (No. PA□□)

POINT
<ul style="list-style-type: none"> ▪ For any parameter whose symbol is preceded by *, set the parameter value and switch power off once, then switch it on again to make that parameter setting valid. ▪ Never change parameters for manufacturer setting.

4.1.1 Parameter list

No.	Symbol	Name	Initial value	Unit	Control mode		
					Position	Internal speed	Internal torque
PA01	*STY	Control mode	000h		<input type="radio"/>	<input type="radio"/>	<input type="radio"/>
PA02	*REG	Regenerative option	000h		<input type="radio"/>	<input type="radio"/>	<input type="radio"/>
PA03		For manufacturer setting	000h				
PA04	*AOP1	Tough drive function selection	000h		<input type="radio"/>	<input type="radio"/>	
PA05	*FBP	Number of command input pulses per revolution	100	×100 pulse/rev	<input type="radio"/>		
PA06	CMX	Electronic gear numerator (Command input pulse multiplying factor numerator)	1		<input type="radio"/>		
PA07	CDV	Electronic gear denominator (Command input pulse multiplying factor denominator)	1		<input type="radio"/>		
PA08	ATU	Auto tuning mode	001h		<input type="radio"/>	<input type="radio"/>	
PA09	RSP	Auto tuning response	6		<input type="radio"/>	<input type="radio"/>	
PA10	INP	In-position range	100	Refer to section 4.1.9.	<input type="radio"/>		
PA11	TLP	Forward torque limit	100	%	<input type="radio"/>	<input type="radio"/>	<input type="radio"/>
PA12	TLN	Reverse torque limit	100	%	<input type="radio"/>	<input type="radio"/>	<input type="radio"/>
PA13	*PLSS	Command input pulse form	000h		<input type="radio"/>		
PA14	*POL	Rotation direction selection	0		<input type="radio"/>		
PA15	*ENR	Encoder output pulses	4000	pulse/rev	<input type="radio"/>	<input type="radio"/>	<input type="radio"/>
PA16	*ENR2	Encoder output pulse electronic gear	0		<input type="radio"/>	<input type="radio"/>	<input type="radio"/>
PA17		For manufacturer setting	000h				
PA18			000h				
PA19	*BLK	Parameter write inhibit	00Eh		<input type="radio"/>	<input type="radio"/>	<input type="radio"/>

4. PARAMETERS

4.1.2 Parameter write inhibit

Parameter			Initial value	Setting range	Unit	Control mode		
No.	Symbol	Name				Position	Internal speed	Internal torque
PA19	*BLK	Parameter write inhibit	00Eh	Refer to the text.		<input type="radio"/>	<input type="radio"/>	<input type="radio"/>

POINT

▪ This parameter is made valid when power is switched off, then on after setting.

In the factory setting, this servo amplifier allows to change all the setting parameters. With the setting of parameter No. PA19, writing can be disabled to prevent accidental changes.

The following table indicates the parameters which are enabled for reference and writing by the setting of parameter No. PA19. Operation can be performed for the parameters marked .

Parameter No. PA19 setting	Setting operation	Basic setting parameters No. PA □□	Gain/Filter parameters No. PB □□	Extension setting parameters No. PC □□	I/O setting parameters No. PD □□	Positioning setting parameters No. PE □□
000h	Reference	<input type="radio"/>	<input type="radio"/>	<input type="radio"/>	<input type="radio"/>	<input type="radio"/>
	Writing	<input type="radio"/>	<input type="radio"/>	<input type="radio"/>	<input type="radio"/>	<input type="radio"/>
00Ah	Reference	Parameter No. PA19 only	<input type="radio"/>	<input type="radio"/>	<input type="radio"/>	<input type="radio"/>
	Writing	Parameter No. PA19 only	<input type="radio"/>	<input type="radio"/>	<input type="radio"/>	<input type="radio"/>
00Bh	Reference	<input type="radio"/>	<input type="radio"/>	<input type="radio"/>	<input type="radio"/>	<input type="radio"/>
	Writing	<input type="radio"/>	<input type="radio"/>	<input type="radio"/>	<input type="radio"/>	<input type="radio"/>
00Ch	Reference	<input type="radio"/>	<input type="radio"/>	<input type="radio"/>	<input type="radio"/>	<input type="radio"/>
	Writing	<input type="radio"/>	<input type="radio"/>	<input type="radio"/>	<input type="radio"/>	<input type="radio"/>
00Eh (initial value)	Reference	<input type="radio"/>	<input type="radio"/>	<input type="radio"/>	<input type="radio"/>	<input type="radio"/>
	Writing	<input type="radio"/>	<input type="radio"/>	<input type="radio"/>	<input type="radio"/>	<input type="radio"/>
10Bh	Reference	<input type="radio"/>	<input type="radio"/>	<input type="radio"/>	<input type="radio"/>	<input type="radio"/>
	Writing	Parameter No. PA19 only	<input type="radio"/>	<input type="radio"/>	<input type="radio"/>	<input type="radio"/>
10Ch	Reference	<input type="radio"/>	<input type="radio"/>	<input type="radio"/>	<input type="radio"/>	<input type="radio"/>
	Writing	Parameter No. PA19 only	<input type="radio"/>	<input type="radio"/>	<input type="radio"/>	<input type="radio"/>
10Eh	Reference	<input type="radio"/>	<input type="radio"/>	<input type="radio"/>	<input type="radio"/>	<input type="radio"/>
	Writing	Parameter No. PA19 only	<input type="radio"/>	<input type="radio"/>	<input type="radio"/>	<input type="radio"/>

4. PARAMETERS

4.1.3 Selection of control mode

Parameter			Initial value	Setting range	Unit	Control mode		
No.	Symbol	Name				Position	Internal speed	Internal torque
PA01	*STY	Control mode	000h	Refer to the text.	<input type="radio"/>	<input type="radio"/>	<input type="radio"/>	

POINT

- This parameter is made valid when power is switched off, then on after setting.

Select the control mode of the servo amplifier, and valid or invalid the one-touch tuning function.

Parameter No. PA01

Selection of control mode

- 0: Position control mode
- 1: Position control mode and internal speed control mode
- 2: Internal speed control mode
- 3: Internal speed control mode and internal torque control mode
- 4: Internal torque control mode
- 5: Internal torque control mode and position control mode
- 6: Positioning mode (point table method)
- 7: Positioning mode (program method)

One-touch tuning function selection

- 0: Valid
 - 1: Invalid
- If "1" is set, the one-touch tuning is ignored.

4.1.4 Selection of regenerative option

Parameter			Initial value	Setting range	Unit	Control mode		
No.	Symbol	Name				Position	Internal speed	Internal torque
PA02	*REG	Regenerative option	000h	Refer to the text.	<input type="radio"/>	<input type="radio"/>	<input type="radio"/>	

POINT

- This parameter is made valid when power is switched off, then on after setting.
- Incorrect setting may cause the regenerative option to burn.
- If the regenerative option selected is not for use with the servo amplifier, parameter error (37.2) occurs.

Set this parameter when using the regenerative option.

Parameter No. PA02

Selection of regenerative option

- 00: Regenerative option is not used
 - For servo amplifier of 100W, regenerative resistor is not used.
 - For servo amplifier of 200 to 400W, built-in regenerative resistor is used.
- 02: MR-RB032
- 03: MR-RB12

4. PARAMETERS

4.1.5 Selection of the tough drive function

Parameter			Initial value	Setting range	Unit	Control mode		
No.	Symbol	Name				Position	Internal speed	Internal torque
PA04	*AOP1	Tough drive function selection	000h	Refer to the text.		○	○	

POINT
<ul style="list-style-type: none"> ▪ This parameter is made valid when power is switched off, then on after setting. ▪ The alarm may not be avoided in the tough drive depending on the conditions of the power supply and the load change. ▪ The during tough drive (MTTR) can be assigned to the CN1-9 pin to CN1-12 pin connector using parameters No. PD15 to PD18. ▪ For details on tough drive function, refer to section 7.1.

By selecting the tough drive function, the operation is continued not to stop the machine in such situation when normally an alarm is activated.

Parameter No. PA04

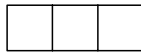

Overload tough drive function selection
Set the tough drive function for overload.
The overload tough drive function is valid only in the position control mode or positioning mode.

Setting	Overload tough drive function
0	Invalid
1	Valid

The details on the overload tough drive function can be set in parameter No. PC26 (detailed setting of overload tough drive).

Vibration tough drive function selection
Set the function for vibration suppression.

Setting	Vibration tough drive function
0	Invalid
1	Valid

The details on the vibration tough drive function can be set in parameter No. PC27 (detailed setting of vibration tough drive).

Instantaneous power failure tough drive function selection
Set the tough drive function for instantaneous power failure of the main circuit power.

Setting	Instantaneous power failure tough drive function
0	Invalid
1	Valid

The details on the instantaneous power failure tough drive function can be set in parameter No. PC28 (detailed setting of instantaneous power failure tough drive).

4. PARAMETERS

4.1.6 Number of command input pulses per servo motor revolution

Parameter			Initial value	Setting range	Unit	Control mode		
No.	Symbol	Name				Position	Internal speed	Internal torque
PA05	*FBP	Number of command input pulses per revolution	100	0 · 100 to 500	× 100 pulse/rev	○		

POINT

- This parameter is made valid when power is switched off, then on after setting.
- Unlike MR-J3-□A servo amplifier, the electronic gear is always valid regardless of the settings of parameter No. PA05.

Set the number of command input pulses necessary to rotate the servo motor one turn.

When "100 (10000[pulse/rev])" (initial value) is set to parameter No. PA05, the servo motor rotates one turn by inputting 10000 pulses of the command pulse to the servo amplifier. When "0" is set to parameter No. PA05, the servo motor rotates one turn by inputting the command pulse of servo motor resolution to the servo amplifier.

Parameter No. PA05 setting	Description
0	Servo motor resolution [pulse/rev]
100 to 500	Number of command input pulses necessary to rotate the servo motor one turn [×100pulse/rev]

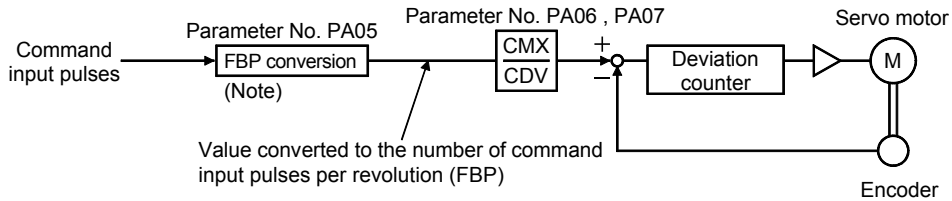

Note. This process converts the number of pulses required to rotate the servo motor one turn to the value set in parameter No. PA05.

4. PARAMETERS

4.1.7 Electronic gear

Parameter			Initial value	Setting range	Unit	Control mode		
No.	Symbol	Name				Position	Internal speed	Internal torque
PA06	CMX	Electronic gear numerator (Command pulse multiplying factor numerator)	1	1 to 65535	/	○	/	/
PA07	CDV	Electronic gear denominator (Command pulse multiplying factor denominator)	1	1 to 65535	/	○	/	/



CAUTION

▪ Incorrect setting may cause unexpectedly fast rotation, resulting injury.

POINT

▪ The electronic gear setting range is $\frac{1}{50} < \frac{CMX}{CDV} < 500$.

If the set value is outside this range, noise may be generated during acceleration/deceleration, or operation may not be performed at the preset speed and/or acceleration/deceleration time constants.

▪ Always set the electronic gear with servo off state to prevent unexpected operation due to improper setting.

(1) Concept of electronic gear

The machine can be moved at any multiplication factor to input pulses.

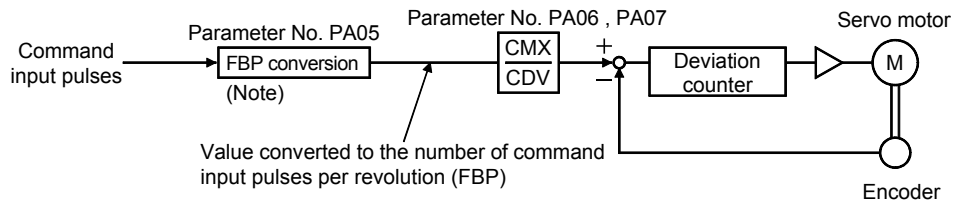

Note. This process converts the number of pulses required to rotate the servo motor one turn to the value set in parameter No. PA05.

$$\frac{CMX}{CDV} = \frac{\text{parameter No. PA06}}{\text{parameter No. PA07}}$$

The following setting examples are used to explain how to calculate the electronic gear.

POINT

▪ The following specification symbols are required to calculate the electronic gear

Pb : Ballscrew lead [mm]

1/n : Reduction ratio

Δl_0 : Travel per command pulse [mm/pulse]

ΔS : Travel per servo motor revolution [mm/rev]

$\Delta \theta_0$: Angle per pulse [$^\circ$ /pulse]

$\Delta \theta$: Angle per revolution [$^\circ$ /rev]

4. PARAMETERS

(a) For motion in increments of 10µm per pulse

Machine specifications

Ballscrew lead $P_b = 10$ [mm]

Reduction ratio: $1/n = Z_1/Z_2 = 1/2$

Z_1 : Number of gear cogs on servo motor side

Z_2 : Number of gear cogs on load side

Command input pulses per revolution: 10000 [pulse/rev]

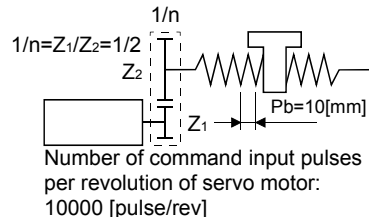

$$\frac{CMX}{CDV} = \Delta l_0 \cdot \frac{10000}{\Delta S} = \Delta l_0 \cdot \frac{10000}{1/n \cdot P_b} = 10 \times 10^{-3} \cdot \frac{10000}{1/2 \cdot 10} = \frac{20}{1}$$

Hence, set 20 to CMX and 1 to CDV.

(b) Conveyor setting example

For rotation in increments of 0.01° per pulse

Machine specifications

Table : 360° /rev

Reduction ratio : $1/n = P_1/P_2 = 625/12544$

P_1 : Pulley diameter on servo motor side

P_2 : Pulley diameter on load side

Command input pulses per revolution: 36000 [pulse/rev]

Number of command input pulses per revolution of servo motor: 36000 [pulse/rev]

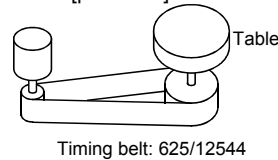

$$\frac{CMX}{CDV} = \Delta \theta_0 \cdot \frac{36000}{\Delta \theta} = 0.01 \cdot \frac{36000}{625/12544 \cdot 360} = \frac{12544}{625} \dots\dots\dots (4.1)$$

Hence, set 12544 to CMX and 625 to CDV.

POINT
<ul style="list-style-type: none"> ▪ In the linear or rotary operation, setting the following values in the number of command input pulses per revolution (parameter No. PA05) simplifies the setting values of the electronic gear (parameter No. PA06, PA07). <ul style="list-style-type: none"> Linear operation: 100 (10000[pulse/rev]) Rotary operation: 360 (36000[pulse/rev])

4. PARAMETERS

(2) Setting for use of QD75

The QD75 also has the following electronic gear parameters. Normally, the servo amplifier side electronic gear must also be set due to the restriction on the command pulse frequency (differential 1Mpulse/s, open collector 200kpulse/s).

AP: Number of pulses per motor revolution

AL: Moving distance per motor revolution

AM: Unit scale factor

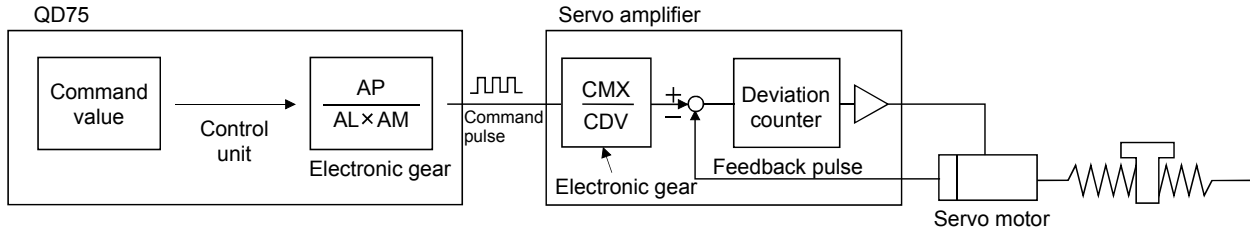

For example, if 100 (1000[pulse/rev]) is set to parameter No. PA05, the pulse command required to rotate the servo motor is as follows.

Servo motor speed [r/min]	Required pulse command
2000	$10000 \times 2000 / 60 = 333333$ [pulse/s]
3000	$10000 \times 3000 / 60 = 500000$ [pulse/s]

Use the electronic gear of the servo amplifier to rotate the servo motor under the maximum output pulse command of the QD75.

To rotate the servo motor at 3000r/min in the open collector system (200kpulse/s), set the electronic gear as follows.

$$f \cdot \frac{CMX}{CDV} = \frac{No}{60} \cdot 10000$$

f : Input pulse frequency [pulse/s]

No : Servo motor speed [r/min]

$$200 \cdot 10^3 \cdot \frac{CMX}{CDV} = \frac{3000}{60} \cdot 10000$$

$$\frac{CMX}{CDV} = \frac{3000}{60} \cdot \frac{10000}{200 \cdot 10^3} = \frac{3000 \cdot 10000}{60 \cdot 200000} = \frac{15}{6}$$

4. PARAMETERS

The following table indicates the electronic gear setting example (ballscrew lead = 10mm) when the QD75 is used in this way.

Rated servo motor speed		3000r/min		2000r/min			
Servo amplifier	Input system	Open collector	Differential line driver	Open collector	Differential line driver		
	Max. input pulse frequency [pulse/s]	200k	1M	200k	1M		
	Feedback pulse/revolution [pulse/rev]	10000		10000			
	Electronic gear (CMX/CDV)	15/6	1/2	5/3	1/3		
AD75P	Command pulse frequency [kpulse/s] (Note)	200k	1M	200k	1M		
	Number of pulses per servo motor revolution as viewed from QD75[pulse/rev]	4000	20000	6000	30000		
	Electronic gear	Minimum command unit 1pulse	AP	1	1	1	1
			AL	1	1	1	1
			AM	1	1	1	1
		Minimum command unit 0.1μm	AP	4000	20000	6000	30000
			AL	1000.0[μm]	1000.0[μm]	1000.0[μm]	1000.0[μm]
AM			10	10	10	10	

Note. Command pulse frequency at rated speed

POINT
<ul style="list-style-type: none"> In addition to the setting method using the electronic gear given here, the number of pulses per servo motor revolution can also be set directly using parameter No. PA05. In this case, parameter No. PA05 is the "Number of pulses per servo motor revolution as viewed from QD75".

4. PARAMETERS

4.1.8 Auto tuning

Parameter			Initial value	Setting range	Unit	Control mode		
No.	Symbol	Name				Position	Internal speed	Internal torque
PA08	ATU	Auto tuning mode	001h	Refer to the text.		<input type="radio"/>	<input type="radio"/>	
PA09	RSP	Auto tuning response	6	1 to 16		<input type="radio"/>	<input type="radio"/>	

POINT

- When executing one-touch tuning, the setting value of parameter No. PA08 is changed to "□□0", and the setting value of parameter No. PA09 is automatically set. (Refer to section 6.1.)

Make gain adjustment using auto tuning. Refer to section 6.3 for details.

(1) Auto tuning mode (parameter No. PA08)

Select the tuning mode.

Parameter No. PA08

0 0 □

Tuning mode setting

Setting	Tuning mode	Estimated load to motor inertia moment ratio	Automatically set parameter No. (Note)	Manually set parameter No. (Note)
0	2-gain adjustment mode	Valid	PB06, PB08, PB09, PB10	PA09, PB07
1	Auto tuning mode 1	Valid	PB06, PB07, PB08, PB09, PB10	PA09
3	Manual mode	Invalid		PB06, PB07, PB08, PB09, PB10

Note. The parameters have the following names.

Parameter No.	Name
PA09	Auto tuning response
PB06	Load to motor inertia moment ratio
PB07	Model loop gain
PB08	Position loop gain
PB09	Speed loop gain
PB10	Speed integral compensation

4. PARAMETERS

(2) Auto tuning response (parameter No. PA09)

If the machine hunts or generates large gear sound, decrease the set value. To improve performance, e.g. shorten the settling time, increase the set value.

Setting	Response
1	Low response
2	
3	
4	
5	
6	
7	
8	
9	
10	
11	
12	
13	
14	
15	
16	High response

4.1.9 In-position range

Parameter			Initial value	Setting range	Unit	Control mode		
No.	Symbol	Name				Position	Internal speed	Internal torque
PA10	INP	In-position range	100	0 to 65535	(Note)	○		

Set the range, where in-position (INP) is output, in the command unit before calculation of the electronic gear. When "□□1" is set to the parameter No. PC24, the range can be changed to the servo motor encoder pulse unit.

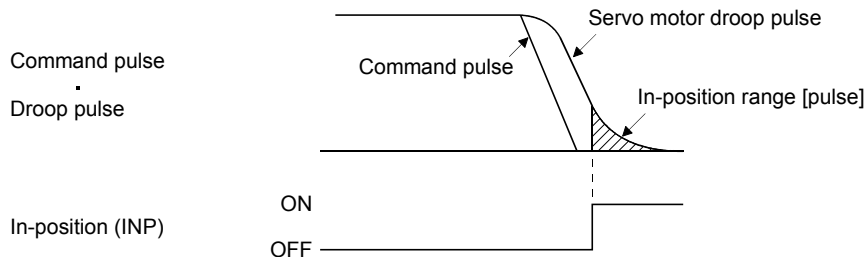

Note. The unit varies depending on the each control mode.

Control mode	Parameter No. PC24 set value	
	□□0	□□1
Position, internal speed, internal torque	pulse	pulse
Positioning	μm	pulse

4. PARAMETERS

4.1.10 Torque limit

Parameter			Initial value	Setting range	Unit	Control mode		
No.	Symbol	Name				Position	Internal speed	Internal torque
PA11	TLP	Forward torque limit	100	0 to 100	%	<input type="radio"/>	<input type="radio"/>	<input type="radio"/>
PA12	TLN	Reverse torque limit	100	0 to 100	%	<input type="radio"/>	<input type="radio"/>	<input type="radio"/>

The torque generated by the servo motor can be limited. Refer to section 3.6.1 (4) and use these parameters.

(1) Forward torque limit (parameter No. PA11)

Set this parameter on the assumption that the maximum torque is 100 [%]. Set this parameter when limiting the torque of the servo motor in the CCW driving mode or CW regeneration mode. Set this parameter to "0" to generate no torque.

(2) Reverse torque limit (parameter No. PA12)

Set this parameter on the assumption that the maximum torque is 100 [%]. Set this parameter when limiting the torque of the servo motor in the CW driving mode or CCW regeneration mode. Set this parameter to "0" to generate no torque.

4. PARAMETERS

4.1.11 Selection of command input pulse form

Parameter			Initial value	Setting range	Unit	Control mode		
No.	Symbol	Name				Position	Internal speed	Internal torque
PA13	*PLSS	Command input pulse form	000h	Refer to the text.		○		

POINT
<ul style="list-style-type: none"> ▪ This parameter is made valid when power is switched off, then on after setting. ▪ The noise immunity can be enhanced by setting parameter No. PA13 to "1 □ □" when the command pulse frequency is 500kpps or less or "2 □ □" when 200kpps or less.

Select the input form of the pulse train input signal. Command pulses may be input in any of three different forms, for which positive or negative logic can be chosen.

Arrow  or  in the table indicates the timing of importing a pulse train.

A- and B-phase pulse trains are imported after being multiplied by 4.

Parameter No. PA13

--	--	--

Selection of command input pulse form

Setting	Pulse train form	Forward rotation command	Reverse rotation command
00	Forward rotation pulse train		
	Reverse rotation pulse train		
	Signed pulse train		
01	A-phase pulse train		
	B-phase pulse train		
	Signed pulse train		
02	Forward rotation pulse train		
	Reverse rotation pulse train		
	Signed pulse train		
10	A-phase pulse train		
	B-phase pulse train		
	Signed pulse train		
11	Forward rotation pulse train		
	Reverse rotation pulse train		
	Signed pulse train		
12	A-phase pulse train		
	B-phase pulse train		
	Signed pulse train		

Pulse train input filter selection

Setting	Command pulse frequency
0	1Mpps or less
1	500kpps or less
2	200kpps or less

4. PARAMETERS

4.1.12 Selection of servo motor rotation direction

Parameter			Initial value	Setting range	Unit	Control mode		
No.	Symbol	Name				Position	Internal speed	Internal torque
PA14	*POL	Rotation direction selection	0	0 · 1		○		

POINT

- This parameter is made valid when power is switched off, then on after setting.

Select servo motor rotation direction relative to the input pulse train.

Parameter No. PA14 setting	Servo motor rotation direction	
	When forward rotation pulse is input	When reverse rotation pulse is input
0	CCW	CW
1	CW	CCW

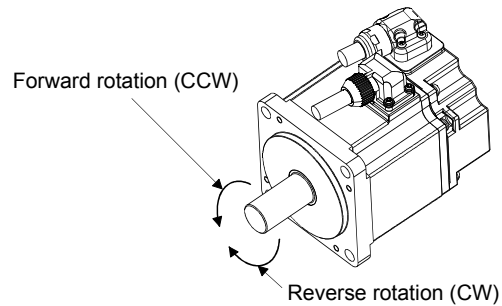

4. PARAMETERS

4.1.13 Encoder output pulses

Parameter			Initial value	Setting range	Unit	Control mode		
No.	Symbol	Name				Position	Internal speed	Internal torque
PA15	*ENR	Encoder output pulses	4000	1 to 65535	pulse/rev	<input type="radio"/>	<input type="radio"/>	<input type="radio"/>
PA16	*ENR2	Encoder output pulse electronic gear	0	0 to 65535		<input type="radio"/>	<input type="radio"/>	<input type="radio"/>

POINT

- This parameter is made valid when power is switched off, then on after setting.

Used to set the encoder pulses (A-phase, B-phase) output by the servo amplifier.

Set the value 4 times greater than the A-phase or B-phase pulses.

You can use parameter No. PC13 to choose the output pulse setting or output division ratio setting.

The number of A/B-phase pulses actually output is 1/4 of the preset number of pulses.

The maximum output frequency is 4.6Mpps (after multiplied by 4). Use this parameter within this range.

(1) For output pulse designation

Set parameter No. PC13 to "□ 0 □" (initial value).

Set the number of pulses per servo motor revolution.

Output pulse = set value [pulses/rev]

For instance, when parameter No. PA15 is set to "5600", the A/B-phase pulses actually output are as indicated below.

$$\text{A-phase/B-phase output pulses} = \frac{5600}{4} = 1400[\text{pulse}]$$

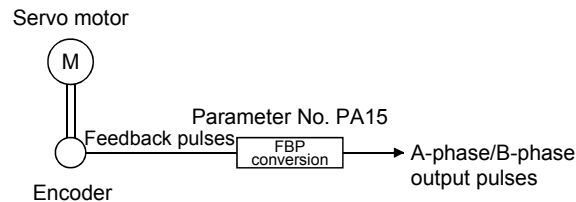

4. PARAMETERS

(2) For output division ratio setting

Set parameter No. PC13 to "□ 1 □".

The number of pulses per servo motor revolution is divided by the set value.

$$\text{Output pulse} = \frac{\text{Resolution per servo motor revolution}}{\text{Setting value}} \text{ [pulse/rev]}$$

For instance, when parameter No. PA15 is set to "8", the A/B-phase pulses actually output are as indicated below.

$$\text{A/B-phase output pulses} = \frac{131072}{8} \cdot \frac{1}{4} = 4096 \text{ [pulse]}$$

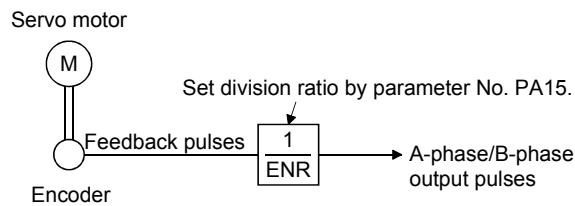

(3) When outputting pulse same as command pulses

Set parameter No. PC13 to "□ 2 □". The feedback pulses from the encoder can be output after being converted to the same value as the command pulse.

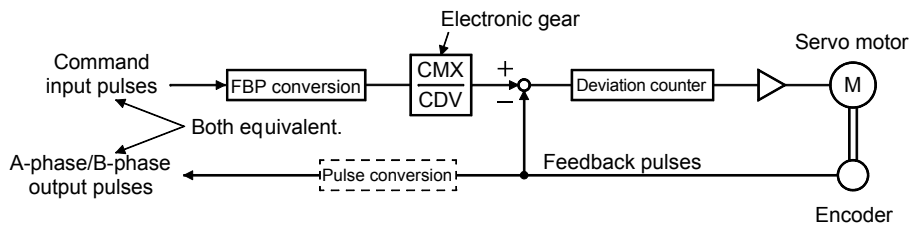

4. PARAMETERS

(4) When multiplying A-phase/B-phase output pulses by the value of the electronic gear

Set parameter No. PC13 to "□ 3 □".

The value resulted from multiplying the number of pulses per servo motor revolution by the value of the electronic gear becomes the output pulse.

(a) Set the electric gear numerator in the A-phase/B-phase output pulses to parameter No. PA15.

(b) Set the electric gear denominator in the A-phase/B-phase output pulses to parameter No. PA16. Setting 0 to parameter No. PA16 is recognized as 1.

(Example) When using the HF-KN servo motor series

When parameter No. PA15 is set to "5600" and PA16 to "4096", the A/B-phase pulses actually outputted are as follows.

A-phase/B-phase output pulses =

$$\text{Resolution per servo motor revolution} \cdot \frac{\text{parameter No.15}}{\text{parameter No.16}} \cdot \frac{1}{4}$$

$$= 131072 \cdot \frac{5600}{4096} \cdot \frac{1}{4} = 44800 \text{ [pulse]}$$

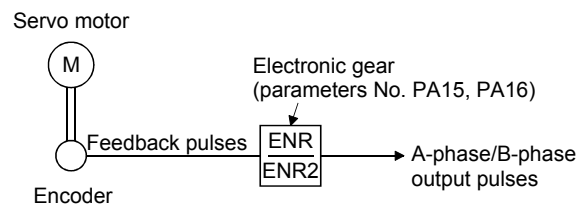

POINT
<ul style="list-style-type: none"> Resolution per servo motor revolution depends on the servo motor as follows. HF-KN series servo motor: 131072pulse/rev HF-KP□G1/G5/G7 servo motor: 262144pulse/rev

4. PARAMETERS

4.2 Gain/filter parameters (No. PB□□)

POINT
<ul style="list-style-type: none"> For any parameter whose symbol is preceded by *, set the parameter value and switch power off once, then switch it on again to make that parameter setting valid. Set any parameter with [Applied] written in the name column when using an advanced function.

4.2.1 Parameter list

No.	Symbol	Name	Initial value	Unit	Control mode		
					Position	Internal speed	Internal torque
PB01	FILT	Adaptive tuning mode (Adaptive filter II)	000h		<input type="radio"/>	<input type="radio"/>	
PB02	VRFT	Vibration suppression control tuning mode (Advanced vibration suppression control)	000h		<input type="radio"/>		
PB03	PST	Position command acceleration/deceleration time constant (Position smoothing)	3	ms	<input type="radio"/>		
PB04	FFC	Feed forward gain [Applied]	0	%	<input type="radio"/>		
PB05		For manufacturer setting	500				
PB06	GD2	Load to motor inertia moment ratio	7.0	Multiplier	<input type="radio"/>	<input type="radio"/>	
PB07	PG1	Model loop gain	24	rad/s	<input type="radio"/>	<input type="radio"/>	
PB08	PG2	Position loop gain	37	rad/s	<input type="radio"/>		
PB09	VG2	Speed loop gain	823	rad/s	<input type="radio"/>	<input type="radio"/>	
PB10	VIC	Speed integral compensation	33.7	ms	<input type="radio"/>	<input type="radio"/>	
PB11	VDC	Speed differential compensation [Applied]	980		<input type="radio"/>	<input type="radio"/>	
PB12	OVA	Overshoot amount compensation [Applied]	0	%	<input type="radio"/>		
PB13	NH1	Machine resonance suppression filter 1	4500	Hz	<input type="radio"/>	<input type="radio"/>	
PB14	NHQ1	Notch shape selection 1	000h		<input type="radio"/>	<input type="radio"/>	
PB15	NH2	Machine resonance suppression filter 2	4500	Hz	<input type="radio"/>	<input type="radio"/>	
PB16	NHQ2	Notch shape selection 2	000h		<input type="radio"/>	<input type="radio"/>	
PB17		Automatic setting parameter					
PB18	LPF	Low-pass filter setting [Applied]	3141	rad/s	<input type="radio"/>	<input type="radio"/>	
PB19	VRF1	Vibration suppression control vibration frequency setting [Applied]	100.0	Hz	<input type="radio"/>		
PB20	VRF2	Vibration suppression control resonance frequency setting [Applied]	100.0	Hz	<input type="radio"/>		
PB21		For manufacturer setting	0				
PB22			0				
PB23	VFBF	Low-pass filter selection [Applied]	000h		<input type="radio"/>	<input type="radio"/>	
PB24		For manufacturer setting	000h				
PB25	*BOP1	Function selection B-1 [Applied]	000h		<input type="radio"/>		
PB26	*CDP	Gain changing selection [Applied]	000h		<input type="radio"/>	<input type="radio"/>	
PB27	CDL	Gain changing condition [Applied]	10	Refer to section 4.2.2.	<input type="radio"/>	<input type="radio"/>	
PB28	CDT	Gain changing time constant [Applied]	1	ms	<input type="radio"/>	<input type="radio"/>	
PB29	GD2B	Gain changing load to motor inertia moment ratio [Applied]	7.0	Multiplier	<input type="radio"/>	<input type="radio"/>	
PB30	PG2B	Gain changing position loop gain [Applied]	37	rad/s	<input type="radio"/>		
PB31	VG2B	Gain changing speed loop gain [Applied]	823	rad/s	<input type="radio"/>	<input type="radio"/>	
PB32	VICB	Gain changing speed integral compensation [Applied]	33.7	ms	<input type="radio"/>	<input type="radio"/>	
PB33	VRF1B	Gain changing vibration suppression control vibration frequency setting [Applied]	100.0	Hz	<input type="radio"/>		

4. PARAMETERS

No.	Symbol	Name	Initial value	Unit	Control mode		
					Position	Internal speed	Internal torque
PB34	VRF2B	Gain changing vibration suppression control resonance frequency setting [Applied]	100.0	Hz	<input type="radio"/>		
PB35		For manufacturer setting	0				
PB36			0				
PB37			100				
PB38	NH3	Machine resonance suppression filter 3	4500	Hz	<input type="radio"/>	<input type="radio"/>	
PB39	NHQ3	Notch shape selection 3	000h		<input type="radio"/>	<input type="radio"/>	
PB40		For manufacturer setting	111h				
PB41			20				
PB42			000h				
PB43			000h				
PB44			000h				
PB45			000h				
PB46			000h				
PB47			000h				
PB48			000h				
PB49			000h				
PB50			000h				

4. PARAMETERS

4.2.2 Detail list

No.	Symbol	Name and function	Initial value	Setting range	Unit	Control mode														
						Position	Internal speed	Internal torque												
PB01	FILT	<p>Adaptive tuning mode (Adaptive filter II)</p> <div style="border: 1px solid black; padding: 5px; margin-bottom: 10px;"> <p>POINT</p> <ul style="list-style-type: none"> When executing one-touch tuning, the adaptive tuning mode starts automatically. When the adaptive filter is set during the one-touch tuning, this parameter is changed to "□□2" automatically. </div> <p>Select if the adaptive tuning is used or not. Setting this parameter to "□□2" (manual mode) enables users to manually adjust the machine resonance suppression filter 1 (parameter No. PB13) and notch shape selection 1 (parameter No. PB14).</p> <p>When this parameter is set to "□□0", the initial values are set for both the machine resonance suppression filter 1 and the notch shape selection 1.</p> <div style="text-align: center;"> </div> <div style="text-align: center; margin-top: 10px;"> <table border="1" style="display: inline-table;"> <tr> <td style="width: 20px; text-align: center;">0</td> <td style="width: 20px; text-align: center;">0</td> <td style="width: 20px; text-align: center;">□</td> </tr> </table> <p>Selection of adaptive tuning mode</p> </div> <table border="1" style="width: 100%; margin-top: 10px;"> <thead> <tr> <th>Setting</th> <th>Adaptive tuning mode</th> <th>Parameter that can be set manually</th> </tr> </thead> <tbody> <tr> <td style="text-align: center;">0</td> <td>Filter OFF</td> <td>(Note)</td> </tr> <tr> <td style="text-align: center;">2</td> <td>Manual mode</td> <td>Parameter No. PB13 Parameter No. PB14</td> </tr> </tbody> </table> <p>Note. Parameter No. PB13 and PB14 are fixed to the initial values.</p>	0	0	□	Setting	Adaptive tuning mode	Parameter that can be set manually	0	Filter OFF	(Note)	2	Manual mode	Parameter No. PB13 Parameter No. PB14	000h	Refer to name and function column.		○	○	
0	0	□																		
Setting	Adaptive tuning mode	Parameter that can be set manually																		
0	Filter OFF	(Note)																		
2	Manual mode	Parameter No. PB13 Parameter No. PB14																		

4. PARAMETERS

No.	Symbol	Name and function	Initial value	Setting range	Unit	Control mode																	
						Position	Internal speed	Internal torque															
PB02	VRFT	<p>Vibration suppression control tuning mode (Advanced vibration suppression control)</p> <div style="border: 1px solid black; padding: 5px; margin: 10px 0;"> <p style="text-align: center;">POINT</p> <ul style="list-style-type: none"> When using the vibration suppression control tuning mode (advanced vibration suppression control) and the one-touch tuning simultaneously, refer to section 7.2.4 (3). </div> <p>The vibration suppression is valid when parameter No. PA08 (auto tuning mode) is set to "□□3". When PA08 is set to "□□1", vibration suppression is always invalid.</p> <p>Select the setting method for vibration suppression control tuning.</p> <p>Setting this parameter to "□□1" (vibration suppression control tuning mode) automatically changes the vibration frequency for vibration suppression control setting (parameter No. PB19) and resonance frequency for vibration suppression control (parameter No. PB20) after positioning operation is performed the predetermined number of times.</p> <div style="text-align: center;"> <p style="text-align: center;">Automatic adjustment</p> </div> <div style="text-align: center; margin-top: 10px;"> <table border="1" style="display: inline-table; border-collapse: collapse;"> <tr> <td style="width: 20px; text-align: center;">0</td> <td style="width: 20px; text-align: center;">0</td> <td style="width: 20px; text-align: center;">□</td> </tr> </table> <p>└─ Vibration suppression control tuning mode</p> </div> <table border="1" style="width: 100%; border-collapse: collapse; margin-top: 10px;"> <thead> <tr> <th style="width: 10%;">Setting</th> <th style="width: 40%;">Vibration suppression control tuning mode</th> <th style="width: 50%;">Automatically set parameter</th> </tr> </thead> <tbody> <tr> <td style="text-align: center;">0</td> <td>Vibration suppression control OFF</td> <td>(Note)</td> </tr> <tr> <td style="text-align: center;">1</td> <td>Vibration suppression control tuning mode (Advanced vibration suppression control)</td> <td>Parameter No. PB19 Parameter No. PB20</td> </tr> <tr> <td style="text-align: center;">2</td> <td>Manual mode</td> <td></td> </tr> </tbody> </table> <p>Note. Parameter No. PB19 and PB20 are fixed to the initial values.</p> <p>When this parameter is set to "□□1", the tuning is completed after positioning is performed the predetermined number of times for the predetermined period of time, and the setting changes to "□□2".</p> <p>When the vibration suppression control tuning is not necessary, the setting changes to "□□0". When this parameter is set to "□□0", the initial values are set to the vibration suppression control vibration frequency setting and vibration suppression control resonance frequency setting. However, this does not occur when the servo off.</p>	0	0	□	Setting	Vibration suppression control tuning mode	Automatically set parameter	0	Vibration suppression control OFF	(Note)	1	Vibration suppression control tuning mode (Advanced vibration suppression control)	Parameter No. PB19 Parameter No. PB20	2	Manual mode		000h	Refer to name and function column.		○		
0	0	□																					
Setting	Vibration suppression control tuning mode	Automatically set parameter																					
0	Vibration suppression control OFF	(Note)																					
1	Vibration suppression control tuning mode (Advanced vibration suppression control)	Parameter No. PB19 Parameter No. PB20																					
2	Manual mode																						

4. PARAMETERS

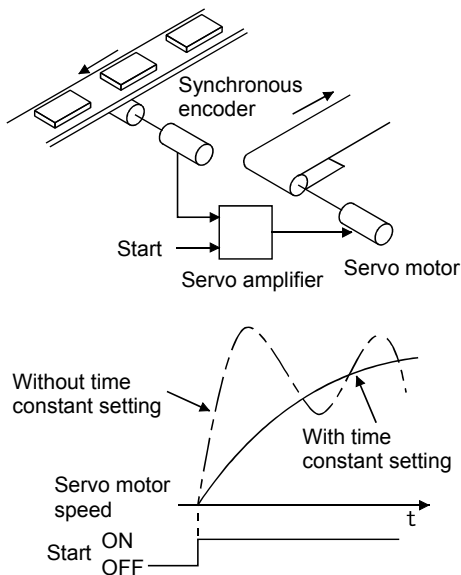
No.	Symbol	Name and function	Initial value	Setting range	Unit	Control mode		
						Position	Internal speed	Internal torque
PB03	PST	<p>Position command acceleration/deceleration time constant (Position smoothing)</p> <p>Used to set the time constant of a low-pass filter in response to the position command.</p> <p>When the one-touch tuning is executed, this parameter is automatically set. (Refer to section 6.1.)</p> <p>The control system of either the primary delay or the linear acceleration/deceleration can be selected by parameter No. PB25. When the linear acceleration/deceleration is selected, the setting range is 0 to 10ms. Setting of longer than 10ms is recognized as 10ms.</p> <div style="border: 1px solid black; padding: 5px; margin: 10px 0;"> <p>POINT</p> <ul style="list-style-type: none"> When the linear acceleration/deceleration is selected, do not execute control switching. Doing so will cause the servo motor to make a sudden stop during the control switching. </div> <p>(Example) When a command is given from a synchronous encoder, synchronous operation can be started smoothly if started during line operation.</p> 	3	0 to 20000	ms	<input type="radio"/>		
PB04	FFC	<p>Feed forward gain [Applied]</p> <p>Set the feed forward gain. When the setting is 100%, the droop pulses during operation at constant speed are nearly zero. However, sudden acceleration/deceleration will increase the overshoot. As a guideline, when the feed forward gain setting is 100%, set 1s or more as the acceleration/deceleration time constant up to the rated speed.</p>	0	0 to 100	%	<input type="radio"/>		
PB05		<p>For manufacturer setting</p> <p>Do not change this value by any means.</p>	500					
PB06	GD2	<p>Load to motor inertia moment ratio</p> <p>Used to set the load to motor inertia moment ratio.</p> <p>When auto tuning mode 1 and 2-gain adjustment mode are selected, this parameter is automatically set. (Refer to section 6.2.) In this case, it varies between 0.0 and 100.0.</p>	7.0	0.0 to 300.0	Multiplier	<input type="radio"/>	<input type="radio"/>	

4. PARAMETERS

No.	Symbol	Name and function	Initial value	Setting range	Unit	Control mode		
						Position	Internal speed	Internal torque
PB07	PG1	<p>Model loop gain</p> <p>Set the response gain up to the target position. As the gain is increased, the track ability in response to the command is improved.</p> <p>When executing the one-touch tuning, the result of the one-touch tuning is automatically set in this parameter.</p> <p>When auto turning mode 1 is selected, the result of auto turning is automatically set in this parameter.</p>	24	1 to 2000	rad/s	<input type="radio"/>	<input type="radio"/>	
PB08	PG2	<p>Position loop gain</p> <p>Used to set the gain of the position loop.</p> <p>Set this parameter to increase the position response level to load disturbance. Higher setting increases the response level but is liable to generate vibration and/or noise.</p> <p>When auto tuning mode 1 and 2-gain adjustment mode are set, the result of auto tuning is automatically set in this parameter.</p>	37	1 to 1000	rad/s	<input type="radio"/>		
PB09	VG2	<p>Speed loop gain</p> <p>Set the gain of the speed loop.</p> <p>Set this parameter when vibration occurs on machines of low rigidity or large backlash.</p> <p>Higher setting increases the response level but is liable to generate vibration and/or noise.</p> <p>When auto tuning mode 1 and 2-gain adjustment mode are set, the result of auto tuning is automatically set in this parameter.</p>	823	20 to 50000	rad/s	<input type="radio"/>	<input type="radio"/>	
PB10	VIC	<p>Speed integral compensation</p> <p>Used to set the integral time constant of the speed loop.</p> <p>Lower setting increases the response level but is liable to generate vibration and/or noise.</p> <p>When auto tuning mode 1 and 2-gain adjustment mode are set, the result of auto tuning is automatically set in this parameter.</p>	33.7	0.1 to 1000.0	ms	<input type="radio"/>	<input type="radio"/>	
PB11	VDC	<p>Speed differential compensation [Applied]</p> <p>Used to set the differential compensation.</p> <p>The set value is made valid when the proportion control (PC) is switched on.</p>	980	0 to 1000		<input type="radio"/>	<input type="radio"/>	
PB12	OVA	<p>Overshoot amount compensation [Applied]</p> <p>Set the suppression ratio of the overshoot suppression control.</p> <p>Set the suppression ratio for the friction torque in %.</p> <p>Executing one-touch tuning automatically changes this parameter.</p> <div style="border: 1px solid black; padding: 5px; margin-top: 10px;"> <p>POINT</p> <ul style="list-style-type: none"> This parameter can reduce the overshoot caused by a device having large friction. </div>	0	0 to 100	%	<input type="radio"/>		
PB13	NH1	<p>Machine resonance suppression filter 1</p> <p>Set the notch frequency of the machine resonance suppression filter 1.</p> <p>Executing one-touch tuning automatically changes this parameter.</p> <p>When parameter No. PB01 is set to "□□0", the setting of this parameter is ignored.</p>	4500	30 to 4500	Hz	<input type="radio"/>	<input type="radio"/>	

4. PARAMETERS

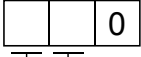
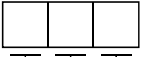
No.	Symbol	Name and function	Initial value	Setting range	Unit	Control mode																														
						Position	Internal speed	Internal torque																												
PB14	NHQ1	<p>Notch shape selection 1 Used to select the machine resonance suppression filter 1.</p>  <table border="1" data-bbox="459 510 722 667"> <caption>Notch depth selection</caption> <thead> <tr> <th>Setting</th> <th>Depth</th> <th>Gain</th> </tr> </thead> <tbody> <tr> <td>0</td> <td>Deep</td> <td>-40dB</td> </tr> <tr> <td>1</td> <td rowspan="2">to</td> <td>-14dB</td> </tr> <tr> <td>2</td> <td>-8dB</td> </tr> <tr> <td>3</td> <td>Shallow</td> <td>-4dB</td> </tr> </tbody> </table> <table border="1" data-bbox="459 712 722 869"> <caption>Notch width selection</caption> <thead> <tr> <th>Setting</th> <th>Width</th> <th>α</th> </tr> </thead> <tbody> <tr> <td>0</td> <td>Standard</td> <td>2</td> </tr> <tr> <td>1</td> <td rowspan="2">to</td> <td>3</td> </tr> <tr> <td>2</td> <td>4</td> </tr> <tr> <td>3</td> <td>Wide</td> <td>5</td> </tr> </tbody> </table> <p>Executing one-touch tuning automatically changes this parameter. When parameter No. PB01 is set to "□□0", the setting of this parameter is ignored.</p>	Setting	Depth	Gain	0	Deep	-40dB	1	to	-14dB	2	-8dB	3	Shallow	-4dB	Setting	Width	α	0	Standard	2	1	to	3	2	4	3	Wide	5	000h	Refer to name and function column.		<input type="radio"/>	<input type="radio"/>	
Setting	Depth	Gain																																		
0	Deep	-40dB																																		
1	to	-14dB																																		
2		-8dB																																		
3	Shallow	-4dB																																		
Setting	Width	α																																		
0	Standard	2																																		
1	to	3																																		
2		4																																		
3	Wide	5																																		
PB15	NH2	<p>Machine resonance suppression filter 2 Set the notch frequency of the machine resonance suppression filter 2. Set parameter No. PB16 (notch shape selection 2) to "□□1" to make this parameter valid. Executing one-touch tuning automatically changes this parameter.</p>	4500	30 to 4500	Hz	<input type="radio"/>	<input type="radio"/>																													
PB16	NHQ2	<p>Notch shape selection 2 Select the shape of the machine resonance suppression filter 2.</p>  <p>Machine resonance suppression filter 2 selection 0: Invalid 1: Valid</p> <table border="1" data-bbox="459 1473 722 1630"> <caption>Notch depth selection</caption> <thead> <tr> <th>Setting</th> <th>Depth</th> <th>Gain</th> </tr> </thead> <tbody> <tr> <td>0</td> <td>Deep</td> <td>-40dB</td> </tr> <tr> <td>1</td> <td rowspan="2">to</td> <td>-14dB</td> </tr> <tr> <td>2</td> <td>-8dB</td> </tr> <tr> <td>3</td> <td>Shallow</td> <td>-4dB</td> </tr> </tbody> </table> <table border="1" data-bbox="459 1675 722 1832"> <caption>Notch width selection</caption> <thead> <tr> <th>Setting</th> <th>Width</th> <th>α</th> </tr> </thead> <tbody> <tr> <td>0</td> <td>Standard</td> <td>2</td> </tr> <tr> <td>1</td> <td rowspan="2">to</td> <td>3</td> </tr> <tr> <td>2</td> <td>4</td> </tr> <tr> <td>3</td> <td>Wide</td> <td>5</td> </tr> </tbody> </table> <p>Executing one-touch tuning automatically changes this parameter.</p>	Setting	Depth	Gain	0	Deep	-40dB	1	to	-14dB	2	-8dB	3	Shallow	-4dB	Setting	Width	α	0	Standard	2	1	to	3	2	4	3	Wide	5	000h	Refer to name and function column.		<input type="radio"/>	<input type="radio"/>	
Setting	Depth	Gain																																		
0	Deep	-40dB																																		
1	to	-14dB																																		
2		-8dB																																		
3	Shallow	-4dB																																		
Setting	Width	α																																		
0	Standard	2																																		
1	to	3																																		
2		4																																		
3	Wide	5																																		
PB17		<p>Automatic setting parameter The value of this parameter is set according to a set value of parameter No. PB06 (load to motor inertia moment ratio).</p>																																		

4. PARAMETERS

No.	Symbol	Name and function	Initial value	Setting range	Unit	Control mode					
						Position	Internal speed	Internal torque			
PB18	LPF	<p>Low-pass filter setting [Applied]</p> <p>Set the low-pass filter.</p> <p>Setting parameter No. PB23 (low-pass filter selection) to "□ 0 □" automatically changes this parameter.</p> <p>When parameter No. PB23 is set to "□ 1 □", this parameter can be set manually.</p>	3141	100 to 9000	rad/s	<input type="radio"/>	<input type="radio"/>				
PB19	VRF1	<p>Vibration suppression control vibration frequency setting [Applied]</p> <p>Set the vibration frequency for vibration suppression control to suppress low-frequency machine vibration, such as enclosure vibration.</p> <p>Setting parameter No. PB02 (vibration suppression control tuning mode) to "□ □ 1" automatically changes this parameter. When parameter No. PB02 is set to "□ □ 2", this parameter can be set manually.</p>	100.0	0.1 to 100.0	Hz	<input type="radio"/>					
PB20	VRF2	<p>Vibration suppression control resonance frequency setting [Applied]</p> <p>Set the resonance frequency for vibration suppression control to suppress low-frequency machine vibration, such as enclosure vibration.</p> <p>Setting parameter No. PB02 (vibration suppression control tuning mode) to "□ □ 1" automatically changes this parameter. When parameter No. PB02 is set to "□ □ 2", this parameter can be set manually.</p>	100.0	0.1 to 100.0	Hz	<input type="radio"/>					
PB21		For manufacturer setting	0								
PB22		Do not change this value by any means.	0								
PB23	VFBF	<p>Low-pass filter selection [Applied]</p> <p>Select the low-pass filter.</p> <div style="border: 1px solid black; display: inline-block; padding: 2px;"> <table style="border-collapse: collapse;"> <tr> <td style="border: 1px solid black; width: 20px; text-align: center;">0</td> <td style="border: 1px solid black; width: 20px;"></td> <td style="border: 1px solid black; width: 20px; text-align: center;">0</td> </tr> </table> </div> <p style="margin-left: 40px;">└── Low-pass filter selection</p> <p style="margin-left: 40px;">0: Automatic setting</p> <p style="margin-left: 40px;">1: Manual setting (parameter No. PB18 setting)</p> <p>When the automatic setting is selected, a filter with band width that is closed to the calculation result of the following formula is selected</p> $\frac{VG2 \cdot 10}{1+GD2} \text{ [rad/s].}$	0		0	000h	Refer to name and function column.		<input type="radio"/>	<input type="radio"/>	
0		0									
PB24		For manufacturer setting	000h								
PB24		Do not change this value by any means.									
PB25	*BOP1	<p>Function selection B-1 [Applied]</p> <p>Select the control systems for position command acceleration/deceleration time constant (parameter No. PB03).</p> <div style="border: 1px solid black; display: inline-block; padding: 2px;"> <table style="border-collapse: collapse;"> <tr> <td style="border: 1px solid black; width: 20px; text-align: center;">0</td> <td style="border: 1px solid black; width: 20px;"></td> <td style="border: 1px solid black; width: 20px; text-align: center;">0</td> </tr> </table> </div> <p style="margin-left: 40px;">└── Control of position command acceleration/ deceleration time constant</p> <p style="margin-left: 40px;">0: Primary delay</p> <p style="margin-left: 40px;">1: Linear acceleration/deceleration</p> <p style="margin-left: 40px;">When linear acceleration/deceleration is selected, do not execute control switching after instantaneous power failure. The servo motor will make a sudden stop during the control switching.</p>	0		0	000h	Refer to name and function column.		<input type="radio"/>		
0		0									

4. PARAMETERS

No.	Symbol	Name and function	Initial value	Setting range	Unit	Control mode		
						Position	Internal speed	Internal torque
PB26	*CDP	<p>Gain changing selection [Applied] Select the gain changing condition. (Refer to section 7.3.)</p> <div style="border: 1px solid black; display: inline-block; padding: 2px; margin-bottom: 5px;">0</div> <p>Gain changing selection Under any of the following conditions, the gains change on the basis of parameter No. PB29 to PB34 settings. 0: Invalid 1: Input device (gain changing (CDP)) 2: Command frequency (parameter No.PB27 setting) 3: Droop pulse (parameter No.PB27 setting) 4: Servo motor speed (parameter No.PB27 setting)</p> <p>Gain changing condition 0: Valid when the input device (gain changing (CDP)) is ON, or valid when the value is equal to or larger than the value set in parameter No. PB27. 1: Valid when the input device (gain changing (CDP)) is OFF, or valid when the value is equal to or smaller than the value set in parameter No. PB27.</p>	000h	Refer to name and function column.		<input type="radio"/>	<input type="radio"/>	
PB27	CDL	<p>Gain changing condition [Applied] Used to set the value of gain changing condition (command frequency, droop pulses, servo motor speed) selected in parameter No. PB26. The set value unit varies depending on the changing condition item. (Refer to section 7.3.)</p>	10	0 to 9999	kpps pulse r/min	<input type="radio"/>	<input type="radio"/>	
PB28	CDT	<p>Gain changing time constant [Applied] Used to set the time constant at which the gains change in response to the conditions set in parameters No. PB26 and PB27. (Refer to section 7.3.)</p>	1	0 to 100	ms	<input type="radio"/>	<input type="radio"/>	
PB29	GD2B	<p>Gain changing load to motor inertia moment ratio [Applied] Used to set the load to motor inertia moment ratio when gain changing is valid. This parameter is made valid when the auto tuning mode is invalid (parameter No. PA08: □□3).</p>	7.0	0.0 to 300.0	Multiplier	<input type="radio"/>	<input type="radio"/>	
PB30	PG2B	<p>Gain changing position loop gain [Applied] Set the position loop gain when the gain changing is valid. This parameter is made valid when the auto tuning mode is invalid (parameter No. PA08: □□3).</p>	37	1 to 2000	rad/s	<input type="radio"/>		
PB31	VG2B	<p>Gain changing speed loop gain [Applied] Set the speed loop gain when the gain changing is valid. This parameter is made valid when the auto tuning mode is invalid (parameter No. PA08: □□3).</p>	823	20 to 50000	rad/s	<input type="radio"/>	<input type="radio"/>	
PB32	VICB	<p>Gain changing speed integral compensation [Applied] Set the speed integral compensation when the gain changing is valid. This parameter is made valid when the auto tuning mode is invalid (parameter No. PA08: □□3).</p>	33.7	0.1 to 5000.0	ms	<input type="radio"/>	<input type="radio"/>	
PB33	VRF1B	<p>Gain changing vibration suppression control vibration frequency setting [Applied] Set the vibration frequency for vibration suppression control when the gain changing is valid. This parameter is made valid when parameter No. PB02 is set to "□□2" and parameter No. PB26 is set to "□□1". When using the vibration suppression control gain changing, always execute the changing after the servo motor has stopped.</p>	100.0	0.1 to 100.0	Hz	<input type="radio"/>		

4. PARAMETERS

No.	Symbol	Name and function	Initial value	Setting range	Unit	Control mode																													
						Position	Internal speed	Internal torque																											
PB34	VRF2B	Gain changing vibration suppression control resonance frequency setting [Applied] Set the resonance frequency for vibration suppression control when the gain changing is valid. This parameter is made valid when parameter No. PB02 is set to "□□2" and parameter No. PB26 is set to "□□1". When using the vibration suppression control gain changing, always execute the changing after the servo motor has stopped.	100.0	0.1 to 100.0	Hz	○	/	/																											
PB35		For manufacturer setting	0																																
PB36		Do not change this value by any means.	0																																
PB37			100																																
PB38	NH3	Machine resonance suppression filter 3 Set the notch frequency of the machine resonance suppression filter 3. Set parameter No. PB39 (notch shape selection 3) to "□□1" to make this parameter valid.	4500	30 to 4500	Hz	○	○	/																											
PB39	NHQ3	Notch shape selection 3 Used to select the machine resonance suppression filter 3.  Machine resonance suppression filter 3 selection 0: Invalid 1: Valid Notch depth selection <table border="1" data-bbox="427 1081 689 1234"> <thead> <tr> <th>Setting</th> <th>Depth</th> <th>Gain</th> </tr> </thead> <tbody> <tr> <td>0</td> <td>Deep</td> <td>-40dB</td> </tr> <tr> <td>1</td> <td rowspan="2">to</td> <td>-14dB</td> </tr> <tr> <td>2</td> <td>-8dB</td> </tr> <tr> <td>3</td> <td>Shallow</td> <td>-4dB</td> </tr> </tbody> </table> Notch width selection <table border="1" data-bbox="427 1283 689 1435"> <thead> <tr> <th>Setting</th> <th>Width</th> <th>α</th> </tr> </thead> <tbody> <tr> <td>0</td> <td>Standard</td> <td>2</td> </tr> <tr> <td>1</td> <td rowspan="2">to</td> <td>3</td> </tr> <tr> <td>2</td> <td>4</td> </tr> <tr> <td>3</td> <td>Wide</td> <td>5</td> </tr> </tbody> </table>	Setting	Depth	Gain	0	Deep	-40dB	1	to	-14dB	2	-8dB	3	Shallow	-4dB	Setting	Width	α	0	Standard	2	1	to	3	2	4	3	Wide	5	000h	Refer to name and function column.	○	○	/
Setting	Depth	Gain																																	
0	Deep	-40dB																																	
1	to	-14dB																																	
2		-8dB																																	
3	Shallow	-4dB																																	
Setting	Width	α																																	
0	Standard	2																																	
1	to	3																																	
2		4																																	
3	Wide	5																																	
PB40		For manufacturer setting	111h																																
PB41		Do not change this value by any means.	20																																
PB42			000h																																
PB43			000h																																
PB44			000h																																
PB45			000h																																
PB46			000h																																
PB47			000h																																
PB48			000h																																
PB49			000h																																
PB50			000h																																

4. PARAMETERS

4.2.3 Position smoothing

By setting the position command acceleration/deceleration time constant (parameter No. PB03), the servo motor is operated smoothly in response to a sudden position command.

The following diagrams show the operation patterns of the servo motor in response to a position command when the position command acceleration/deceleration time constant is set.

Select the primary delay or linear acceleration/deceleration in parameter No. PB25 according to the machine used.

(1) For step input

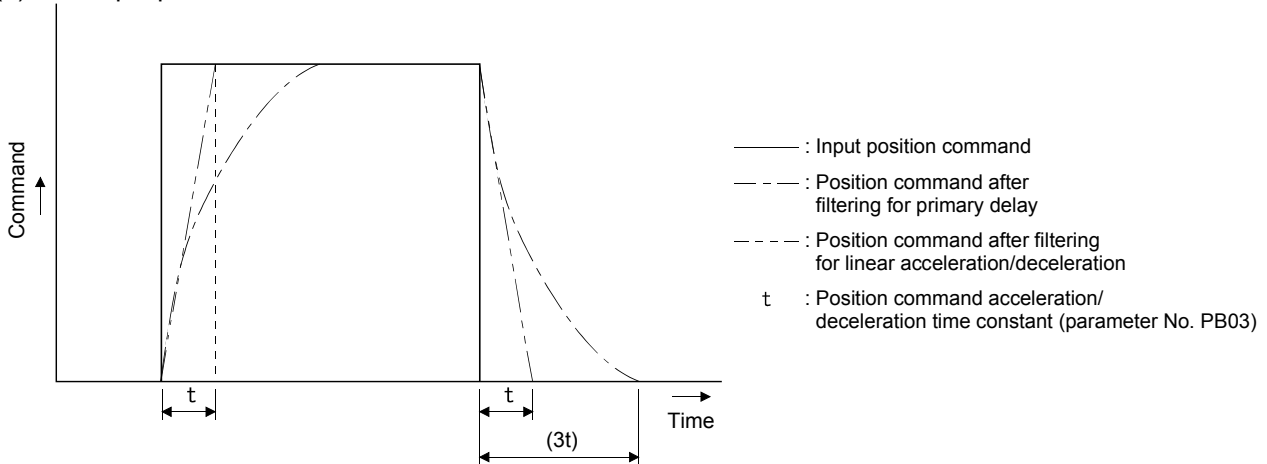

(2) For trapezoidal input

For trapezoidal input (linear acceleration/deceleration), the setting range is 0 to 10ms.

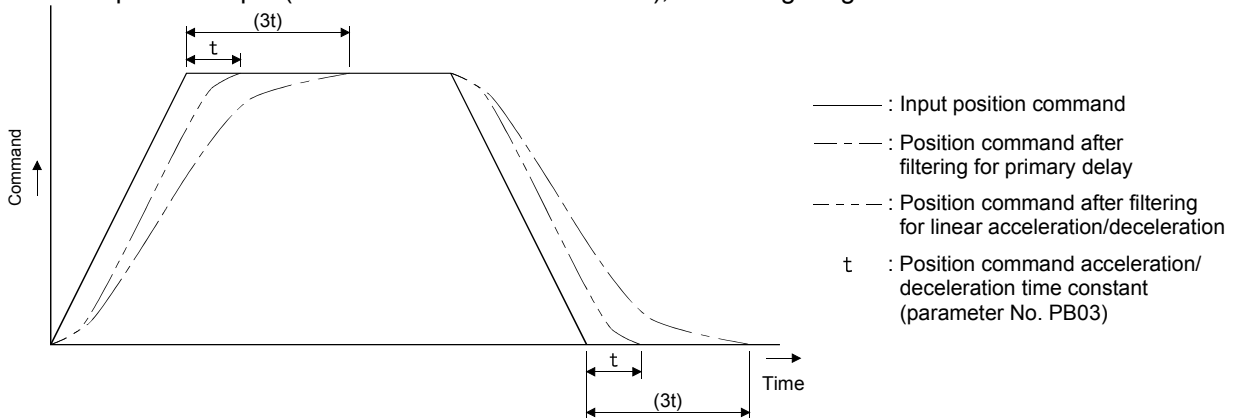

4. PARAMETERS

4.3 Extension setting parameters (No. PC□□)

POINT
<ul style="list-style-type: none"> ▪ For any parameter whose symbol is preceded by *, set the parameter value and switch power off once, then switch it on again to make that parameter setting valid. ▪ Set any parameter with [Applied] written in the name column when using an advanced function.

4.3.1 Parameter list

No.	Symbol	Name	Initial value	Unit	Control mode		
					Position	Internal speed	Internal torque
PC01	STA	Acceleration time constant	0	ms	/	○	○
PC02	STB	Deceleration time constant	0	ms	/	○	○
PC03	STC	S-pattern acceleration/deceleration time constant	0	ms	/	○	○
PC04	TQC	Torque command time constant	0	ms	/	/	○
PC05	SC0	Internal speed command 0	0	r/min	/	○	/
		Internal speed limit 0			/	/	○
PC06	SC1	Internal speed command 1	100	r/min	/	○	/
		Internal speed limit 1			/	/	○
PC07	SC2	Internal speed command 2	500	r/min	/	○	/
		Internal speed limit 2			/	/	○
PC08	SC3	Internal speed command 3	1000	r/min	/	○	/
		Internal speed limit 3			/	/	○
PC09	MBR	Electromagnetic brake sequence output	100	ms	○	○	○
PC10	ZSP	Zero speed	50	r/min	○	○	○
PC11	*BPS	Alarm history clear	000h	/	○	○	○
PC12	TC	Internal torque command	0.0	%	/	/	○
PC13	*ENRS	Encoder output pulses selection	000h	/	○	○	○
PC14	TL2	Internal torque limit 2 [Applied]	100	%	○	○	○
PC15	ERZL	Error excessive alarm detection level	3.0	rev	○	○	○
PC16	/	For manufacturer setting	30	/	/	/	/
PC17	*OSL	Overspeed alarm detection level	0	r/min	○	○	○
PC18	/	For manufacturer setting	1000	/	/	/	/
PC19	/		0	/	/	/	/
PC20	/		000h	/	/	/	/
PC21	/		001h	/	/	/	/
PC22	*COP1	Function selection C-1 [Applied]	000h	/	○	○	○
PC23	*COP2	Function selection C-2 [Applied]	000h	/	/	○	/
PC24	*COP3	Function selection C-3 [Applied]	000h	/	○	/	/
PC25	*COP4	Function selection C-4 [Applied]	000h	/	○	○	/
PC26	ALDT	Detailed setting of overload tough drive [Applied]	200	×10ms	○	/	/
PC27	OSCL	Detailed setting of vibration tough drive [Applied]	50	%	○	○	/
PC28	CVAT	Detailed setting of instantaneous power failure tough drive [Applied]	3	×10ms	○	○	/
PC29	*COP5	Function selection C-5 [Applied]	000h	/	○	○	○
PC30	*COP6	Function selection C-6 [Applied]	000h	/	/	○	/
PC31	SC4	Internal speed command 4 [Applied]	200	r/min	/	○	/
		Internal speed limit 4 [Applied]			/	/	○
PC32	SC5	Internal speed command 5 [Applied]	300	r/min	/	○	/
		Internal speed limit 5 [Applied]			/	/	○

4. PARAMETERS

No.	Symbol	Name	Initial value	Unit	Control mode			
					Position	Internal speed	Internal torque	
PC33	SC6	Internal speed command 6 [Applied]	500	r/min		○		
		Internal speed limit 6 [Applied]						○
PC34	SC7	Internal speed command 7 [Applied]	800	r/min		○		
		Internal speed limit 7 [Applied]						○
PC35		For manufacturer setting	000h					
PC36			0					
PC37			0					
PC38			0					
PC39			0					
PC40			0					
PC41			000h					
PC42			0					
PC43			000h					
PC44			RECT					Drive recorder alarm specifying
PC45		For manufacturer setting	000h					
PC46			000h					
PC47			000h					
PC48			000h					
PC49			000h					
PC50			000h					
PC51			000h					
PC52			000h					
PC53			000h					
PC54			000h					
PC55			000h					
PC56			000h					
PC57			000h					
PC58			000h					
PC59			000h					
PC60			000h					
PC61			000h					
PC62			000h					
PC63			000h					
PC64			000h					

4. PARAMETERS

4.3.2 List of details

No.	Symbol	Name and function	Initial value	Setting range	Unit	Control mode		
						Position	Internal speed	Internal torque
PC01	STA	<p>Acceleration time constant</p> <p>Used to set the acceleration time required for the servo motor to reach the rated speed from 0r/min in response to the internal speed commands 0 to 7.</p> <p>For example for the servo motor of 3000r/min rated speed, set 3000 (3s) to increase speed from 0r/min to 1000r/min in 1 second.</p>	0	0 to 50000	ms		<input type="radio"/>	<input type="radio"/>
PC02	STB	<p>Deceleration time constant</p> <p>Used to set the deceleration time required for the servo motor to reach 0r/min from the rated speed in response to the internal speed commands 0 to 7.</p>	0	0 to 50000	ms		<input type="radio"/>	<input type="radio"/>

4. PARAMETERS

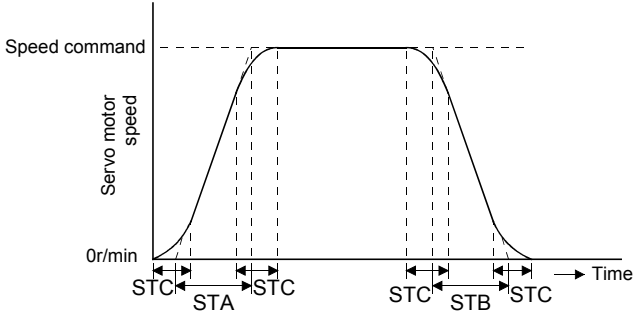
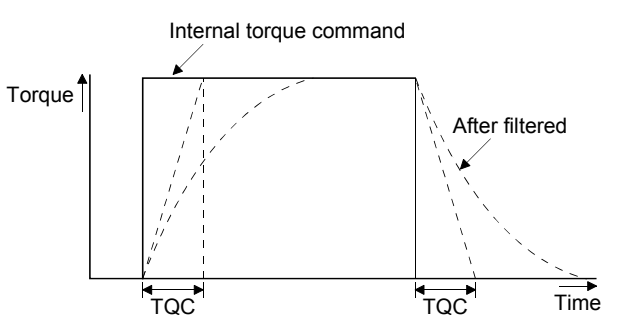
No.	Symbol	Name and function	Initial value	Setting range	Unit	Control mode		
						Position	Internal speed	Internal torque
PC03	STC	<p>S-pattern acceleration/deceleration time constant Used to smooth start/stop of the servo motor. Set the time of the arc part for S-pattern acceleration/deceleration. Set "0" to select the linear acceleration/deceleration.</p>  <p>STA: Acceleration time constant (parameter No. PC01) STB: Deceleration time constant (parameter No. PC02) STC: S-pattern acceleration/deceleration time constant (parameter No. PC03)</p> <p>Long setting of STA (acceleration time constant) or STB (deceleration time constant) may produce an error in the time of the arc part for the setting of the S-pattern acceleration/deceleration time constant.</p> <p>The upper limit for the actual time of the arc part is as follows: At acceleration: $\frac{2000000}{STA}$, At deceleration: $\frac{2000000}{STB}$</p> <p>(Example) Settings of STA = 20000, STB = 5000 and STC = 200 limit the actual arc part times as follows:</p> <p>At acceleration: 100 [ms] $\left(\text{Since } \frac{2000000}{20000} = 100[\text{ms}] < 200[\text{ms}], \text{ the time is limited to } 100[\text{ms}]. \right)$</p> <p>At deceleration: 200 [ms] $\left(\text{Since } \frac{2000000}{5000} = 400[\text{ms}] > 200[\text{ms}], \text{ the time is as-is.} \right)$</p>	0	0 to 1000	ms		<input type="radio"/>	<input type="radio"/>
PC04	TQC	<p>Torque command time constant Used to set the constant of a low-pass filter in response to the internal torque command.</p>  <p>TQC: Torque command time constant</p>	0	0 to 20000	ms			<input type="radio"/>

4. PARAMETERS

No.	Symbol	Name and function	Initial value	Setting range	Unit	Control mode		
						Position	Internal speed	Internal torque
PC05	SC0	Internal speed command 0 Used to set speed 0 of internal speed commands.	0	0 to instantaneous permissible speed	r/min	/	○	/
		Internal speed limit 0 Used to set speed 0 of internal speed limits.						
PC06	SC1	Internal speed command 1 Used to set speed 1 of internal speed commands.	100	0 to instantaneous permissible speed	r/min	/	○	/
		Internal speed limit 1 Used to set speed 1 of internal speed limits.						
PC07	SC2	Internal speed command 2 Used to set speed 2 of internal speed commands.	500	0 to instantaneous permissible speed	r/min	/	○	/
		Internal speed limit 2 Used to set speed 2 of internal speed limits.						
PC08	SC3	Internal speed command 3 Used to set speed 3 of internal speed commands.	1000	0 to instantaneous permissible speed	r/min	/	○	/
		Internal speed limit 3 Used to set speed 3 of internal speed limits.						
PC09	MBR	Electromagnetic brake sequence output Used to set the delay time (Tb) from the electromagnetic brake interlock (MBR) turns off to the base drive circuit is shut-off.	100	0 to 1000	ms	○	○	○
PC10	ZSP	Zero speed Used to set the output range of the zero speed detection (ZSP). Zero speed detection (ZSP) has hysteresis width of 20r/min (refer to section 3.5 (1) (b))	50	0 to 10000	r/min	○	○	○
PC11	*BPS	Alarm history clear Used to clear the alarm history. <div style="border: 1px solid black; padding: 2px; display: inline-block; margin-bottom: 5px;"> 0 </div> <ul style="list-style-type: none"> └ Alarm history clear 0: Invalid 1: Valid When alarm history clear is made valid, the alarm history and the number of tough drive are cleared at next power-on. After the alarm history and the number of tough drive are cleared, the setting is automatically made invalid (reset to 0). └ Presence or absence of drive recorder selection 0: Valid (drive recorder execution) 1: Invalid (drive recorder stop) MR Configurator is necessary referring to the drive recorder. (Refer to Section 4.3.4.) 	000h	Refer to the name and function field.		○	○	○
PC12	TC	Internal torque command Set the internal torque command during the internal torque control.	0.0	0.0 to 100.0	%	/	/	○

4. PARAMETERS

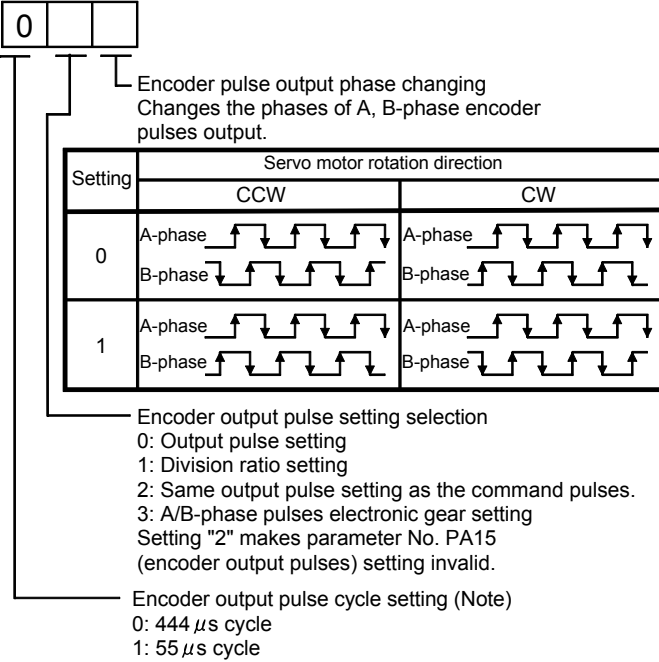
No.	Symbol	Name and function	Initial value	Setting range	Unit	Control mode																	
						Position	Internal speed	Internal torque															
PC13	*ENRS	<p>Encoder output pulses selection Used to select the encoder output pulse direction, the encoder output pulse setting and the encoder output pulse cycle.</p>  <p>Encoder pulse output phase changing Changes the phases of A, B-phase encoder pulses output.</p> <table border="1" data-bbox="359 593 957 840"> <thead> <tr> <th rowspan="2">Setting</th> <th colspan="2">Servo motor rotation direction</th> </tr> <tr> <th>CCW</th> <th>CW</th> </tr> </thead> <tbody> <tr> <td rowspan="2">0</td> <td>A-phase </td> <td>A-phase </td> </tr> <tr> <td>B-phase </td> <td>B-phase </td> </tr> <tr> <td rowspan="2">1</td> <td>A-phase </td> <td>A-phase </td> </tr> <tr> <td>B-phase </td> <td>B-phase </td> </tr> </tbody> </table> <p>Encoder output pulse setting selection 0: Output pulse setting 1: Division ratio setting 2: Same output pulse setting as the command pulses. 3: A/B-phase pulses electronic gear setting Setting "2" makes parameter No. PA15 (encoder output pulses) setting invalid.</p> <p>Encoder output pulse cycle setting (Note) 0: 444 μs cycle 1: 55 μs cycle</p> <p>Note. It is supported by servo amplifiers of the software version A1 or later.</p>	Setting	Servo motor rotation direction		CCW	CW	0	A-phase	A-phase	B-phase	B-phase	1	A-phase	A-phase	B-phase	B-phase	000h	Refer to the name and function field.		<input type="radio"/>	<input type="radio"/>	<input type="radio"/>
Setting	Servo motor rotation direction																						
	CCW	CW																					
0	A-phase	A-phase																					
	B-phase	B-phase																					
1	A-phase	A-phase																					
	B-phase	B-phase																					
PC14	TL2	<p>Internal torque limit 2 [Applied] Set this parameter to limit servo motor torque on the assumption that the maximum torque is 100[%]. When 0 is set, torque is not produced. The internal torque limit 2 is made valid when the internal torque limit selection (TL1) is turned on. (Refer to (4) in section 3.6.1.)</p>	100	0 to 100	%	<input type="radio"/>	<input type="radio"/>	<input type="radio"/>															
PC15	ERZL	<p>Error excessive alarm detection level Set the error excessive alarm detection level.</p>	3.0	0.1 to 99.9	rev	<input type="radio"/>	<input type="radio"/>	<input type="radio"/>															
PC16		<p>For manufacturer setting Do not change this value by any means.</p>	30																				
PC17	*OSL	<p>Overspeed alarm detection level Set the overspeed alarm detection level. When "0" or "value exceeding the maximum servo motor speed \times 1.2" is set, the overspeed alarm detection level becomes "maximum motor speed \times 1.2".</p>	0	0 to 20000	r/min	<input type="radio"/>	<input type="radio"/>	<input type="radio"/>															
PC18		<p>For manufacturer setting</p>	1000																				
PC19		<p>Do not change this value by any means.</p>	0																				
PC20			000h																				
PC21			001h																				

4. PARAMETERS

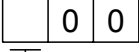
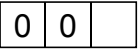
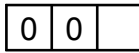
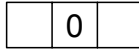
No.	Symbol	Name and function	Initial value	Setting range	Unit	Control mode		
						Position	Internal speed	Internal torque
PC22	*COP1	Function selection C-1 [Applied] Select the encoder cable communication system.  Encoder cable communication system 0: Two-wire type 1: Four-wire type Incorrect setting will result in an encoder transmission data error 3 (The servo amplifier not receiving) (16.3). For the encoder cable communication method, refer to section 11.1.2.	000h	Refer to the name and function field.		○	○	○
PC23	*COP2	Function selection C-2 [Applied] Select the servo lock while the servo motor stops in internal speed control mode.  Selection of servo lock while the servo motor stops in internal speed control mode. In the internal speed control mode, the servo motor shaft can be locked to prevent the shaft from being moved by the external force. 0: Valid (Servo-locked) The control to maintain the stop position is performed. 1: Invalid (Not servo-locked) The stop position is not maintained. The control to make the speed 0r/min is performed.	000h	Refer to the name and function field.			○	
PC24	*COP3	Function selection C-3 [Applied] Select the unit of the in-position range.  In-position range unit selection 0: Command input unit 1: Servo motor encoder pulse unit	000h	Refer to the name and function field.		○		
PC25	*COP4	Function selection C-4 [Applied] Select the stroke limit warning (99. □), tough drive warning (F0. □) and alarm history write.  Stroke limit warning (99. □) selection 0: Valid 1: Invalid When this parameter is set to "1", the stroke limit warning (99. □) will not occur even if the forward rotation stroke end (LSP) or reverse rotation stroke end (LSN) turns OFF. Tough drive warning (F0. □) alarm history write selection 0: Writing to alarm history: Yes 1: Writing to alarm history: No The alarm is written to history at the tough drive warning (F0. □) occurrence when "0" is set.	000h	Refer to the name and function field.		○	○	

4. PARAMETERS

No.	Symbol	Name and function	Initial value	Setting range	Unit	Control mode					
						Position	Internal speed	Internal torque			
PC26	ALDT	<p>Detailed setting of overload tough drive [Applied]</p> <p>Limits the maximum value of the output time delay of the in-position (INP) and zero speed (ZSP) while the overload tough drive. Limit with the delay time permitted by the connected controller side.</p> <p>When parameter No. PA04 (tough drive function selection) is set to "□□0" and this parameter (No. PC26) is set to "0", the output time delay of the in-position (INP) and zero speed (ZSP) are invalid.</p>	200	0 to 999	×10 ms	<input type="radio"/>					
PC27	OSCL	<p>Detailed setting of vibration tough drive [Applied]</p> <p>Set the filter reset detection range of parameter No. PB13 (machine resonance suppression filter 1) and parameter No. PB15 (machine resonance suppression filter 2).</p> <p>(Example) When this parameter is set to "50", it is reset when the oscillation detection level reaches 50% of the rated torque.</p> <p>When parameter No. PA04 (tough drive function selection) is set to "□0□", resets of the following filters are invalid: parameter No. PB13 (machine resonance suppression filter 1) and parameter No. PB15 (machine resonance suppression filter 2).</p>	50	0 to 100	%	<input type="radio"/>	<input type="radio"/>				
PC28	CVAT	<p>Detailed setting of instantaneous power failure tough drive [Applied]</p> <p>Set the time between the fall of the main circuit power supply to the alarm detection level and the occurrence of the instantaneous power failure alarm.</p> <p>When parameter No. PA04 (tough drive function selection) is set to "0□□", this parameter is invalid.</p>	3	3 to 200	×10 ms	<input type="radio"/>	<input type="radio"/>				
PC29	*COP5	<p>Function selection C-5 [Applied]</p> <p>Select the detection method of the main circuit power undervoltage alarm (10.2)</p> <table border="1" style="margin-left: 20px;"> <tr> <td style="width: 20px; text-align: center;">0</td> <td style="width: 20px; text-align: center;">□</td> <td style="width: 20px; text-align: center;">0</td> </tr> </table> <p>Select the detection method of the main circuit power undervoltage alarm (10.2)</p> <p>0: Undervoltage alarm (10.2) is detected regardless of the servo motor speed</p> <p>1: When the servo motor speed is 50r/min or less, main circuit power off warning (E9.□) is detected</p>	0	□	0	000h	Refer to the name and function field.		<input type="radio"/>	<input type="radio"/>	<input type="radio"/>
0	□	0									
PC30	*COP6	<p>Function selection C-6 [Applied]</p> <p>Select the speed command input unit.</p> <table border="1" style="margin-left: 20px;"> <tr> <td style="width: 20px; text-align: center;">0</td> <td style="width: 20px; text-align: center;">0</td> <td style="width: 20px; text-align: center;">□</td> </tr> </table> <p>Selection of the speed command input unit (setting unit of internal speed command 0 to 7)</p> <p>0: In unit of 1r/min</p> <p>1: In unit of 0.1r/min</p>	0	0	□	000h	Refer to the name and function field.		<input type="radio"/>		
0	0	□									
PC31	SC4	Internal speed command 4 [Applied]	200	0 to instantaneous permissible speed	r/min		<input type="radio"/>				
		Internal speed limit 4 [Applied]						<input type="radio"/>			
		Used to set speed 4 of internal speed commands.									
		Used to set speed 4 of internal speed limits.									

4. PARAMETERS

No.	Symbol	Name and function	Initial value	Setting range	Unit	Control mode		
						Position	Internal speed	Internal torque
PC32	SC5	Internal speed command 5 [Applied] Used to set speed 5 of internal speed commands.	300	0 to instantaneous permissible speed	r/min	/	○	/
		Internal speed limit 5 [Applied] Used to set speed 5 of internal speed limits.						
PC33	SC6	Internal speed command 6 [Applied] Used to set speed 6 of internal speed commands.	500	0 to instantaneous permissible speed	r/min	/	○	/
		Internal speed limit 6 [Applied] Used to set speed 6 of internal speed limits.						
PC34	SC7	Internal speed command 7 [Applied] Used to set speed 7 of internal speed commands.	800	0 to instantaneous permissible speed	r/min	/	○	/
		Internal speed limit 7 [Applied] Used to set speed 7 of internal speed limits.						
PC35	/	For manufacturer setting Do not change this value by any means.	000h	/	/	/	/	/
PC36			0					
PC37			0					
PC38			0					
PC39			0					
PC40			0					
PC41			000h					
PC42			0					
PC43			000h					
PC44			RECT					
PC45	/	For manufacturer setting Do not change this value by any means.	000h	/	/	/	/	/
PC46			000h					
PC47			000h					
PC48			000h					
PC49			000h					
PC50			000h					
PC51			000h					
PC52			000h					
PC53			000h					
PC54			000h					
PC55			000h					
PC56			000h					

4. PARAMETERS

No.	Symbol	Name and function	Initial value	Setting range	Unit	Control mode		
						Position	Internal speed	Internal torque
PC57			000h					
PC58			000h					
PC59		For manufacturer setting Do not change this value by any means.	000h					
PC60			000h					
PC61			000h					
PC62			000h					
PC63			000h					
PC64			000h					

4.3.3 Alarm history clear

The servo amplifier stores past 16 alarms since the power is switched on for the first time. To control alarms which will occur during the operation, clear the alarm history using parameter No. PC11 before starting the operation. This parameter is made valid by switching the power from OFF to ON after setting. The value in parameter No. PC11 automatically changes to "□□0" after the alarm history is cleared.

Parameter No. PC11

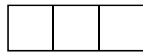

Alarm history clear
 0: Invalid (not cleared)
 1: Valid (cleared)

4. PARAMETERS

4.3.4 Drive recorder function

POINT
<ul style="list-style-type: none">▪ Records the state transition when an alarm occurs. However, the previously recorded data is discarded. If another alarm occurs while an alarm is occurring, the state transition during that another alarm is not recorded.▪ The drive recorder does not operate in the following situation.<ul style="list-style-type: none">▪ When the number of record times reaches 255.▪ When the number of write times to alarm history after power-on reaches 16. The number of record times can be confirmed on the display (alarm mode). (Refer to section 5.5.)▪ The drive recorder does not operate when the following alarms occur.<ul style="list-style-type: none">▪ Undervoltage (10.1 or 10.3)▪ Memory error 1 (RAM) (12. □)▪ Memory error 2 (EEP-ROM) (15. □)▪ Encoder initial communication error 1 (16. □)▪ Board error (17. □)▪ Memory error 3 (Flash-ROM) (19. □)▪ Motor combination error (1A. □)▪ Software combination error (1C. □)▪ Encoder initial communication error 2 (1E. □)▪ Encoder initial communication error 3 (1F. □)▪ Parameter error (37. □)▪ Watchdog (888)▪ When the graph is displayed in MR Configurator, the drive recorder function becomes invalid. To make the drive recorder function valid again, switch the power off then on. Valid/invalid of drive recorder function can be confirmed on the display (diagnostic mode). (Refer to section 5.4.)

The drive recorder function records the state transition before and after the alarm occurrence for the predetermined period of time by always monitoring the servo status. The recorded data can be confirmed on the graph display screen by clicking the "drive recorder display" button on the alarm history display screen of MR Configurator. After shifting to the graph display screen, the drive recorder function becomes invalid. The recorded data can be displayed with the analog 3CH or digital 4CH as in the graph function of MR Configurator.

(1) Parameter setting

Select valid/invalid of the drive recorder function in parameter No. PC11.

Parameter No. PC11

	0	
--	---	--

Presence or absence of drive recorder selection
0 : Valid (drive recorder execution)
1 : Invalid (drive recorder stop)
MR Configurator is required to refer to the drive recorder.

4. PARAMETERS

Specify the alarm No. in parameter No. PC44 when operating the drive recorder with the specific alarm No.

Parameter No. PC44

0		
---	--	--

Specification of alarm No.

00 : No specification

(The optimum item is recorded according to the alarms that have occurred earlier and operating conditions.)

01 to FFh : Specification

(The specified item is recorded when an alarm of the specified alarm No. occurs.)

When a non-existent alarm No. is specified, the specified value is recognized as "00h".

(2) Record data

(a) When the set value of parameter No. PC44 is "□□00":

1) When alarms to be recorded by the drive recorder function are in the alarm history:

The specified data are automatically selected and recorded based on the alarm history.

a) Analog CH data

Three data for 3CH are automatically selected from the data listed below.

- Servo motor speed [r/min]
- Torque [%]
- Bus voltage (Note)
- Within one-revolution position [pulse]
- Multi-revolution counter [rev]
- Current command [%]
- Regenerative load ratio [%]
- Command pulse frequency [kpps]
- Effective load ratio [%]

Note. The bus voltage is displayed in five steps.

Display value	Description
5	Overvoltage (About 400V or more)
4	High voltage (About 375V or more)
3	Normal
2	Low voltage (About 200V or less)
1	Undervoltage (About 160V or less)

b) Digital CH (4CH) data

Four data for 4CH are automatically selected from the data listed below.

- Trouble (ALM)
- Forced stop (EM1)
- Servo-on (SON)
- Electromagnetic brake interlock (MBR)
- Main circuit power supply OFF
- Ready (RD)
- Limiting torque (TLC)

2) When alarms to be recorded by the drive recorder function are not in the alarm history:

The data to be recorded are as indicated in the following table.

Analog CH data		Digital CH data				Sampling time [ms]	Measuring length [ms] (64 points)
		CH1 (trigger)	CH2	CH3	CH4		
CH1	Servo motor speed [r/min]	ALM	EM1	SON	RD	0.8	56.8
CH2	Torque [%]						
CH3	Within one-revolution position [pulse]						

4. PARAMETERS

- (b) When the set value of parameter No. PC44 is other than "□ 00":
The data to be recorded are as indicated in the following table.

Setting	Corresponding alarm No.	Analog CH data		Digital CH data				Sampling time [ms]	Measuring length [ms] (64 points)
				CH1 (trigger)	CH2	CH3	CH4		
□ 10	10.2	CH1	Servo motor speed [r/min]	ALM	EM1	MBR	(Main circuit power supply is OFF.)	0.8	56.8
		CH2	Torque [%]						
		CH3	Bus voltage (Note)						
□ 13	13. □	CH1	Servo motor speed [r/min]	ALM	EM1	SON	RD	0.8	56.8
		CH2	Torque [%]						
		CH3	Within one-revolution position [pulse]						
□ 20	20. □	CH1	Servo motor speed [r/min]	ALM	EM1	SON	RD	0.8	56.8
		CH2	Within one-revolution position [pulse]						
		CH3	Multi-revolution counter [rev]						
□ 21	21. □	CH1	Servo motor speed [r/min]	ALM	EM1	SON	RD	0.8	56.8
		CH2	Within one-revolution position [pulse]						
		CH3	Multi-revolution counter [rev]						
□ 24	24. □	CH1	Servo motor speed [r/min]	ALM	EM1	SON	RD	0.8	56.8
		CH2	Torque [%]						
		CH3	Current command [%]						
□ 30	30. □	CH1	Servo motor speed [r/min]	ALM	EM1	SON	RD	56.8	3600
		CH2	Torque [%]						
		CH3	Regenerative load ratio [%]						
□ 31	31. □	CH1	Servo motor speed [r/min]	ALM	EM1	SON	RD	0.8	56.8
		CH2	Torque [%]						
		CH3	Command pulse frequency [kpps]						
□ 32	32. □	CH1	Servo motor speed [r/min]	ALM	EM1	SON	RD	0.8	56.8
		CH2	Torque [%]						
		CH3	Current command [%]						
□ 33	33. □	CH1	Servo motor speed [r/min]	ALM	EM1	SON	RD	3.5	227
		CH2	Torque [%]						
		CH3	Bus voltage (Note)						
□ 35	35. □	CH1	Servo motor speed [r/min]	ALM	EM1	SON	RD	0.8	56.8
		CH2	Torque [%]						
		CH3	Command pulse frequency [kpps]						
□ 39	39. □	CH1	Servo motor speed [r/min]	ALM	EM1	SON	RD	0.8	56.8
		CH2	Torque [%]						
		CH3	Within one-revolution position [pulse]						
□ 45	45. □	CH1	Servo motor speed [r/min]	ALM	EM1	SON	RD	0.8	56.8
		CH2	Torque [%]						
		CH3	Within one-revolution position [pulse]						
□ 46	46. □	CH1	Servo motor speed [r/min]	ALM	EM1	MBR	RD	56.8	3600
		CH2	Torque [%]						
		CH3	Effective load ratio [%]						
□ 50	50. □	CH1	Servo motor speed [r/min]	ALM	EM1	MBR	RD	56.8	3600
		CH2	Torque [%]						
		CH3	Effective load ratio [%]						
□ 51	51. □	CH1	Servo motor speed [r/min]	ALM	EM1	MBR	RD	56.8	3600
		CH2	Torque [%]						
		CH3	Effective load ratio [%]						

4. PARAMETERS

Setting	Corresponding alarm No.	Analog CH data		Digital CH data				Sampling time [ms]	Measuring length [ms] (64 points)
				CH1 (trigger)	CH2	CH3	CH4		
□ 52	52. □	CH1	Servo motor speed [r/min]	ALM	EM1	RD	TLC	3.5	227
		CH2	Torque [%]						
		CH3	Droop pulses [pulse] (unit: 100 pulses)						
□ 61	61. □	CH1	Servo motor speed [r/min]	ALM	EM1	SON	RD	0.8	56.8
		CH2	Torque [%]						
		CH3	Within one-revolution position [pulse]						
□ 8E	8E. □	CH1	Servo motor speed [r/min]	ALM	EM1	SON	RD	0.8	56.8
		CH2	Torque [%]						
		CH3	Within one-revolution position [pulse]						

Note. The bus voltage is displayed in five steps.

Display value	Description
5	Overvoltage (About 400V or more)
4	High voltage (About 375V or more)
3	Normal
2	Low voltage (About 200V or less)
1	Undervoltage (About 160V or less)

4. PARAMETERS

4.4 I/O setting parameters (No. PD□□)

POINT
<ul style="list-style-type: none"> ▪ For any parameter whose symbol is preceded by *, set the parameter value and switch power off once, then switch it on again to make that parameter setting valid. ▪ In the positioning mode, refer to section 13.7.4 (2) for the parameter No. PD20.

4.4.1 Parameter list

No.	Symbol	Name	Initial value	Unit	Control mode		
					Position	Internal speed	Internal torque
PD01	*DIA1	Input signal automatic ON selection 1	0000h		○	○	○
PD02	*DI0	Input signal device selection 0 (CN1-23, CN1-25)	262Dh			○	○
PD03	*DI1-1	Input signal device selection 1L (CN1-3)	0303h		○	○	
PD04	*DI1-2	Input signal device selection 1H (CN1-3)	2003h				○
PD05	*DI2-1	Input signal device selection 2L (CN1-4)	0202h		○	○	
PD06	*DI2-2	Input signal device selection 2H (CN1-4)	0202h				○
PD07	*DI3-1	Input signal device selection 3L (CN1-5)	0D06h		○	○	
PD08	*DI3-2	Input signal device selection 3H (CN1-5)	2C0Dh				○
PD09	*DI4-1	Input signal device selection 4L (CN1-6)	070Ah		○	○	
PD10	*DI4-2	Input signal device selection 4H (CN1-6)	0707h				○
PD11	*DI5-1	Input signal device selection 5L (CN1-7)	080Bh		○	○	
PD12	*DI5-2	Input signal device selection 5H (CN1-7)	0808h				○
PD13	*DI6-1	Input signal device selection 6L (CN1-8)	0505h		○	○	
PD14	*DI6-2	Input signal device selection 6H (CN1-8)	0505h				○
PD15	*DO1	Output signal device selection 1 (CN1-9)	0003h		○	○	○
PD16	*DO2	Output signal device selection 2 (CN1-10)	0004h		○	○	○
PD17	*DO3	Output signal device selection 3 (CN1-11)	0002h		○	○	○
PD18	*DO4	Output signal device selection 4 (CN1-12)	0005h		○	○	○
PD19	*DIF	Input filter setting	0002h		○	○	○
PD20	*DOP1	Function selection D-1	0000h		○	○	○
PD21		For manufacturer setting	0000h				
PD22	*DOP3	Function selection D-3	0000h		○		
PD23		For manufacturer setting	0000h				
PD24	*DOP5	Function selection D-5	0000h		○	○	○
PD25		For manufacturer setting	0000h				
PD26			0000h				

4. PARAMETERS

4.4.2 List of details

No.	Symbol	Name and function	Initial value	Setting range	Unit	Control mode																																																				
						Position	Internal speed	Internal torque																																																		
PD01	*DIA1	<p>Input signal automatic ON selection 1 Select the input devices to be automatically turned ON.</p> <table border="1" style="margin-left: 20px;"> <thead> <tr> <th rowspan="2">Signal name</th> <th colspan="2">Initial value</th> </tr> <tr> <th>BIN</th> <th>HEX</th> </tr> </thead> <tbody> <tr> <td>Automatic/manual selection (MD0)</td> <td>0</td> <td rowspan="3">0</td> </tr> <tr> <td>Servo-on (SON)</td> <td>0</td> </tr> <tr> <td></td> <td>0</td> </tr> </tbody> </table> <table border="1" style="margin-left: 20px;"> <thead> <tr> <th rowspan="2">Signal name</th> <th colspan="2">Initial value</th> </tr> <tr> <th>BIN</th> <th>HEX</th> </tr> </thead> <tbody> <tr> <td>Proportion control (PC)</td> <td>0</td> <td rowspan="3">0</td> </tr> <tr> <td>Forced stop (EM1)</td> <td>0</td> </tr> <tr> <td></td> <td>0</td> </tr> </tbody> </table> <table border="1" style="margin-left: 20px;"> <thead> <tr> <th rowspan="2">Signal name</th> <th colspan="2">Initial value</th> </tr> <tr> <th>BIN</th> <th>HEX</th> </tr> </thead> <tbody> <tr> <td>Forward rotation stroke end (LSP)</td> <td>0</td> <td rowspan="3">0</td> </tr> <tr> <td>Reverse rotation stroke end (LSN)</td> <td>0</td> </tr> <tr> <td></td> <td>0</td> </tr> </tbody> </table> <table border="1" style="margin-left: 20px;"> <thead> <tr> <th rowspan="2">Signal name</th> <th colspan="2">Initial value</th> </tr> <tr> <th>BIN</th> <th>HEX</th> </tr> </thead> <tbody> <tr> <td>Point table No./Program No. selection 1 (DI0)</td> <td>0</td> <td rowspan="4">0</td> </tr> <tr> <td>Point table No./Program No. selection 2 (DI1)</td> <td>0</td> </tr> <tr> <td>Point table No./Program No. selection 3 (DI2)</td> <td>0</td> </tr> <tr> <td></td> <td>0</td> </tr> </tbody> </table> <p style="margin-left: 20px;">BIN 0: Used as external input signal BIN 1: Automatic ON</p> <p>Example 1: Turn ON SON The setting is " □ □ □ 4".</p> <p>Example 2: Turn ON LSP/LSN</p> <ul style="list-style-type: none"> • To turn ON LSP only: The setting is " □ 4 □ □". • To turn ON LSN only: The setting is " □ 8 □ □". • To turn ON both LSP and LSN: The setting is " □ C □ □". <div style="border: 1px solid black; padding: 5px; margin-top: 10px;"> <p>POINT</p> <ul style="list-style-type: none"> ▪ The input status of LSP and LSN differs depending on their assignment conditions as follows. ▪ Assigned to the external input signals: depends on the value set in parameter No. PD01. ▪ Not assigned to the external input signals: automatically turns on regardless of the value set in parameter No. PD01. </div>	Signal name	Initial value		BIN	HEX	Automatic/manual selection (MD0)	0	0	Servo-on (SON)	0		0	Signal name	Initial value		BIN	HEX	Proportion control (PC)	0	0	Forced stop (EM1)	0		0	Signal name	Initial value		BIN	HEX	Forward rotation stroke end (LSP)	0	0	Reverse rotation stroke end (LSN)	0		0	Signal name	Initial value		BIN	HEX	Point table No./Program No. selection 1 (DI0)	0	0	Point table No./Program No. selection 2 (DI1)	0	Point table No./Program No. selection 3 (DI2)	0		0	0000h	Refer to the name and function field.		○	○	○
Signal name	Initial value																																																									
	BIN	HEX																																																								
Automatic/manual selection (MD0)	0	0																																																								
Servo-on (SON)	0																																																									
	0																																																									
Signal name	Initial value																																																									
	BIN	HEX																																																								
Proportion control (PC)	0	0																																																								
Forced stop (EM1)	0																																																									
	0																																																									
Signal name	Initial value																																																									
	BIN	HEX																																																								
Forward rotation stroke end (LSP)	0	0																																																								
Reverse rotation stroke end (LSN)	0																																																									
	0																																																									
Signal name	Initial value																																																									
	BIN	HEX																																																								
Point table No./Program No. selection 1 (DI0)	0	0																																																								
Point table No./Program No. selection 2 (DI1)	0																																																									
Point table No./Program No. selection 3 (DI2)	0																																																									
	0																																																									

4. PARAMETERS

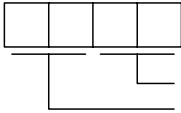
No.	Symbol	Name and function	Initial value	Setting range	Unit	Control mode																																																																																																																																																																	
						Position	Internal speed	Internal torque																																																																																																																																																															
PD02	*D10	<p>Input signal device selection 0 (CN1-23, CN1-25) Any input device can be assigned to the CN1-23 pin and CN1-25 pin (forward and reverse rotation pulse trains). For the position control mode, position/internal speed change mode or internal torque/position control change mode, CN1-23 pin is fixed to PP or CN1-25 pin to NP. For the internal speed control mode or the internal torque control mode, PP or NP can not be assigned.</p>  <p>The devices that can be assigned in each control mode are indicated by abbreviation in the following table. If any other device is set, it is invalid.</p> <table border="1" data-bbox="316 728 901 1742"> <thead> <tr> <th rowspan="2">Setting</th> <th colspan="4">Control modes (Note 1)</th> </tr> <tr> <th>P</th> <th>S</th> <th>T</th> <th>CP/CL</th> </tr> </thead> <tbody> <tr> <td>00</td> <td></td> <td></td> <td></td> <td>CN1-23 pin: PP CN1-25 pin: NP</td> </tr> <tr> <td>01</td> <td></td> <td colspan="3">For manufacturer setting (Note 2)</td> </tr> <tr> <td>02</td> <td></td> <td>SON</td> <td>SON</td> <td>SON</td> </tr> <tr> <td>03</td> <td></td> <td>RES</td> <td>RES</td> <td>RES</td> </tr> <tr> <td>04</td> <td></td> <td>PC</td> <td></td> <td>PC</td> </tr> <tr> <td>05 (Note 4)</td> <td></td> <td>EM1</td> <td>EM1</td> <td>EM1</td> </tr> <tr> <td>06</td> <td></td> <td colspan="3">For manufacturer setting (Note 2)</td> </tr> <tr> <td>07</td> <td></td> <td>ST1</td> <td>RS2</td> <td>ST1</td> </tr> <tr> <td>08</td> <td></td> <td>ST2</td> <td>RS1</td> <td>ST2</td> </tr> <tr> <td>09</td> <td></td> <td>TL1</td> <td></td> <td>TL1</td> </tr> <tr> <td>0A</td> <td></td> <td>LSP</td> <td></td> <td>LSP</td> </tr> <tr> <td>0B</td> <td></td> <td>LSN</td> <td></td> <td>LSN</td> </tr> <tr> <td>0C</td> <td></td> <td colspan="3">For manufacturer setting (Note 2)</td> </tr> <tr> <td>0D</td> <td></td> <td>SP1</td> <td>SP1</td> <td></td> </tr> <tr> <td>0E</td> <td></td> <td>SP2</td> <td>SP2</td> <td></td> </tr> <tr> <td>0F</td> <td>CN1-23 pin: PP</td> <td>SP3</td> <td>SP3</td> <td></td> </tr> <tr> <td>10</td> <td>CN1-25 pin: NP</td> <td>LOP</td> <td>LOP</td> <td></td> </tr> <tr> <td>11</td> <td></td> <td>CDP</td> <td></td> <td>CDP</td> </tr> <tr> <td>12 to 1F</td> <td></td> <td></td> <td></td> <td>For manufacturer setting (Note 2)</td> </tr> <tr> <td>20</td> <td></td> <td></td> <td></td> <td>MD0</td> </tr> <tr> <td>21 to 23</td> <td></td> <td></td> <td></td> <td>For manufacturer setting (Note 2)</td> </tr> <tr> <td>24</td> <td></td> <td></td> <td></td> <td>TSTP</td> </tr> <tr> <td>25</td> <td></td> <td></td> <td></td> <td>For manufacturer setting (Note 2)</td> </tr> <tr> <td>26</td> <td></td> <td></td> <td></td> <td>DOG</td> </tr> <tr> <td>27</td> <td></td> <td></td> <td></td> <td>PI1(Note 3)</td> </tr> <tr> <td>28 to 2B</td> <td></td> <td></td> <td></td> <td>For manufacturer setting (Note 2)</td> </tr> <tr> <td>2C</td> <td></td> <td></td> <td></td> <td>D10</td> </tr> <tr> <td>2D</td> <td></td> <td></td> <td></td> <td>D11</td> </tr> <tr> <td>2E</td> <td></td> <td></td> <td></td> <td>D12</td> </tr> <tr> <td>2F to 3F</td> <td></td> <td></td> <td></td> <td>For manufacturer setting (Note 2)</td> </tr> </tbody> </table> <p>Note 1. P: Position control mode S: Internal speed control mode T: Internal torque control mode CP: Positioning mode (Point table method) CL: Positioning mode (Program method) 2. For manufacturer setting. Never set this value. 3. It is valid in the positioning mode (Program method) only. 4. When operating temporarily without using EM1 such as at startup, etc., set the EM1 to automatic ON in parameter No.PD01.</p>	Setting	Control modes (Note 1)				P	S	T	CP/CL	00				CN1-23 pin: PP CN1-25 pin: NP	01		For manufacturer setting (Note 2)			02		SON	SON	SON	03		RES	RES	RES	04		PC		PC	05 (Note 4)		EM1	EM1	EM1	06		For manufacturer setting (Note 2)			07		ST1	RS2	ST1	08		ST2	RS1	ST2	09		TL1		TL1	0A		LSP		LSP	0B		LSN		LSN	0C		For manufacturer setting (Note 2)			0D		SP1	SP1		0E		SP2	SP2		0F	CN1-23 pin: PP	SP3	SP3		10	CN1-25 pin: NP	LOP	LOP		11		CDP		CDP	12 to 1F				For manufacturer setting (Note 2)	20				MD0	21 to 23				For manufacturer setting (Note 2)	24				TSTP	25				For manufacturer setting (Note 2)	26				DOG	27				PI1(Note 3)	28 to 2B				For manufacturer setting (Note 2)	2C				D10	2D				D11	2E				D12	2F to 3F				For manufacturer setting (Note 2)	262Dh	Refer to the name and function field.			<input type="radio"/>	<input type="radio"/>
Setting	Control modes (Note 1)																																																																																																																																																																						
	P	S	T	CP/CL																																																																																																																																																																			
00				CN1-23 pin: PP CN1-25 pin: NP																																																																																																																																																																			
01		For manufacturer setting (Note 2)																																																																																																																																																																					
02		SON	SON	SON																																																																																																																																																																			
03		RES	RES	RES																																																																																																																																																																			
04		PC		PC																																																																																																																																																																			
05 (Note 4)		EM1	EM1	EM1																																																																																																																																																																			
06		For manufacturer setting (Note 2)																																																																																																																																																																					
07		ST1	RS2	ST1																																																																																																																																																																			
08		ST2	RS1	ST2																																																																																																																																																																			
09		TL1		TL1																																																																																																																																																																			
0A		LSP		LSP																																																																																																																																																																			
0B		LSN		LSN																																																																																																																																																																			
0C		For manufacturer setting (Note 2)																																																																																																																																																																					
0D		SP1	SP1																																																																																																																																																																				
0E		SP2	SP2																																																																																																																																																																				
0F	CN1-23 pin: PP	SP3	SP3																																																																																																																																																																				
10	CN1-25 pin: NP	LOP	LOP																																																																																																																																																																				
11		CDP		CDP																																																																																																																																																																			
12 to 1F				For manufacturer setting (Note 2)																																																																																																																																																																			
20				MD0																																																																																																																																																																			
21 to 23				For manufacturer setting (Note 2)																																																																																																																																																																			
24				TSTP																																																																																																																																																																			
25				For manufacturer setting (Note 2)																																																																																																																																																																			
26				DOG																																																																																																																																																																			
27				PI1(Note 3)																																																																																																																																																																			
28 to 2B				For manufacturer setting (Note 2)																																																																																																																																																																			
2C				D10																																																																																																																																																																			
2D				D11																																																																																																																																																																			
2E				D12																																																																																																																																																																			
2F to 3F				For manufacturer setting (Note 2)																																																																																																																																																																			

4. PARAMETERS

No.	Symbol	Name and function	Initial value	Setting range	Unit	Control mode																																																																																																																																																																					
						Position	Internal speed	Internal torque																																																																																																																																																																			
PD03	*DI1-1	<p>Input signal device selection 1L (CN1-3)</p> <p>Any input signal can be assigned to the CN1-3 pin.</p> <p>Note that the setting digits and the signal that can be assigned vary depending on the control mode.</p> <div style="display: flex; align-items: center; margin-top: 10px;"> <table border="1" style="border-collapse: collapse; text-align: center;"> <tr> <td style="width: 20px; height: 20px;"></td> <td style="width: 20px; height: 20px;"></td> <td style="width: 20px; height: 20px;"></td> <td style="width: 20px; height: 20px;"></td> </tr> </table> <div style="margin-left: 10px;"> <p>Position control mode</p> <p>Internal speed control mode</p> </div> <div style="margin-left: 20px; font-size: 2em;">}</div> <div style="margin-left: 10px;"> <p>Select the input device of the CN1-3 pin.</p> </div> </div> <p>The devices that can be assigned in each control mode are indicated by symbols in the following table. If any other device is set, it is invalid.</p> <table border="1" style="width: 100%; border-collapse: collapse; text-align: center;"> <thead> <tr> <th rowspan="2">Setting</th> <th colspan="4">Control modes (Note 1)</th> </tr> <tr> <th>P</th> <th>S</th> <th>T</th> <th>CP/CL</th> </tr> </thead> <tbody> <tr> <td>00</td> <td></td> <td></td> <td></td> <td></td> </tr> <tr> <td>01</td> <td colspan="4">For manufacturer setting (Note 2)</td> </tr> <tr> <td>02</td> <td>SON</td> <td>SON</td> <td>SON</td> <td>SON</td> </tr> <tr> <td>03</td> <td>RES</td> <td>RES</td> <td>RES</td> <td>RES</td> </tr> <tr> <td>04</td> <td>PC</td> <td>PC</td> <td></td> <td>PC</td> </tr> <tr> <td>05 (Note 4)</td> <td>EM1</td> <td>EM1</td> <td>EM1</td> <td>EM1</td> </tr> <tr> <td>06</td> <td>CR</td> <td></td> <td></td> <td></td> </tr> <tr> <td>07</td> <td></td> <td>ST1</td> <td>RS2</td> <td>ST1</td> </tr> <tr> <td>08</td> <td></td> <td>ST2</td> <td>RS1</td> <td>ST2</td> </tr> <tr> <td>09</td> <td>TL1</td> <td>TL1</td> <td></td> <td>TL1</td> </tr> <tr> <td>0A</td> <td>LSP</td> <td>LSP</td> <td></td> <td>LSP</td> </tr> <tr> <td>0B</td> <td>LSN</td> <td>LSN</td> <td></td> <td>LSN</td> </tr> <tr> <td>0C</td> <td colspan="4">For manufacturer setting (Note 2)</td> </tr> <tr> <td>0D</td> <td></td> <td>SP1</td> <td>SP1</td> <td></td> </tr> <tr> <td>0E</td> <td></td> <td>SP2</td> <td>SP2</td> <td></td> </tr> <tr> <td>0F</td> <td></td> <td>SP3</td> <td>SP3</td> <td></td> </tr> <tr> <td>10</td> <td>LOP</td> <td>LOP</td> <td>LOP</td> <td></td> </tr> <tr> <td>11</td> <td>CDP</td> <td>CDP</td> <td></td> <td>CDP</td> </tr> <tr> <td>12 to 1F</td> <td colspan="4">For manufacturer setting (Note 2)</td> </tr> <tr> <td>20</td> <td></td> <td></td> <td></td> <td>MD0</td> </tr> <tr> <td>21 to 23</td> <td></td> <td></td> <td></td> <td>For manufacturer setting (Note 2)</td> </tr> <tr> <td>24</td> <td></td> <td></td> <td></td> <td>TSTP</td> </tr> <tr> <td>25</td> <td></td> <td></td> <td></td> <td>For manufacturer setting (Note 2)</td> </tr> <tr> <td>26</td> <td></td> <td></td> <td></td> <td>DOG</td> </tr> <tr> <td>27</td> <td></td> <td></td> <td></td> <td>PI1 (Note 3)</td> </tr> <tr> <td>28 to 2B</td> <td></td> <td></td> <td></td> <td>For manufacturer setting (Note 2)</td> </tr> <tr> <td>2C</td> <td></td> <td></td> <td></td> <td>DIO</td> </tr> <tr> <td>2D</td> <td></td> <td></td> <td></td> <td>DI1</td> </tr> <tr> <td>2E</td> <td></td> <td></td> <td></td> <td>DI2</td> </tr> <tr> <td>2F to 3F</td> <td></td> <td></td> <td></td> <td>For manufacturer setting (Note 2)</td> </tr> </tbody> </table> <p>Note 1. P: Position control mode S: Internal speed control mode T: Internal torque control mode CP: Positioning mode (Point table method) CL: Positioning mode (Program method)</p> <p>2. For manufacturer setting. Never set this value.</p> <p>3. It is valid in the positioning mode (Program method) only.</p> <p>4. When operating temporarily without using EM1 such as at startup, etc., set the EM1 to automatic ON in parameter No.PD01.</p>					Setting	Control modes (Note 1)				P	S	T	CP/CL	00					01	For manufacturer setting (Note 2)				02	SON	SON	SON	SON	03	RES	RES	RES	RES	04	PC	PC		PC	05 (Note 4)	EM1	EM1	EM1	EM1	06	CR				07		ST1	RS2	ST1	08		ST2	RS1	ST2	09	TL1	TL1		TL1	0A	LSP	LSP		LSP	0B	LSN	LSN		LSN	0C	For manufacturer setting (Note 2)				0D		SP1	SP1		0E		SP2	SP2		0F		SP3	SP3		10	LOP	LOP	LOP		11	CDP	CDP		CDP	12 to 1F	For manufacturer setting (Note 2)				20				MD0	21 to 23				For manufacturer setting (Note 2)	24				TSTP	25				For manufacturer setting (Note 2)	26				DOG	27				PI1 (Note 3)	28 to 2B				For manufacturer setting (Note 2)	2C				DIO	2D				DI1	2E				DI2	2F to 3F				For manufacturer setting (Note 2)	0303h	Refer to the name and function field.		○	○	
Setting	Control modes (Note 1)																																																																																																																																																																										
	P	S	T	CP/CL																																																																																																																																																																							
00																																																																																																																																																																											
01	For manufacturer setting (Note 2)																																																																																																																																																																										
02	SON	SON	SON	SON																																																																																																																																																																							
03	RES	RES	RES	RES																																																																																																																																																																							
04	PC	PC		PC																																																																																																																																																																							
05 (Note 4)	EM1	EM1	EM1	EM1																																																																																																																																																																							
06	CR																																																																																																																																																																										
07		ST1	RS2	ST1																																																																																																																																																																							
08		ST2	RS1	ST2																																																																																																																																																																							
09	TL1	TL1		TL1																																																																																																																																																																							
0A	LSP	LSP		LSP																																																																																																																																																																							
0B	LSN	LSN		LSN																																																																																																																																																																							
0C	For manufacturer setting (Note 2)																																																																																																																																																																										
0D		SP1	SP1																																																																																																																																																																								
0E		SP2	SP2																																																																																																																																																																								
0F		SP3	SP3																																																																																																																																																																								
10	LOP	LOP	LOP																																																																																																																																																																								
11	CDP	CDP		CDP																																																																																																																																																																							
12 to 1F	For manufacturer setting (Note 2)																																																																																																																																																																										
20				MD0																																																																																																																																																																							
21 to 23				For manufacturer setting (Note 2)																																																																																																																																																																							
24				TSTP																																																																																																																																																																							
25				For manufacturer setting (Note 2)																																																																																																																																																																							
26				DOG																																																																																																																																																																							
27				PI1 (Note 3)																																																																																																																																																																							
28 to 2B				For manufacturer setting (Note 2)																																																																																																																																																																							
2C				DIO																																																																																																																																																																							
2D				DI1																																																																																																																																																																							
2E				DI2																																																																																																																																																																							
2F to 3F				For manufacturer setting (Note 2)																																																																																																																																																																							

4. PARAMETERS

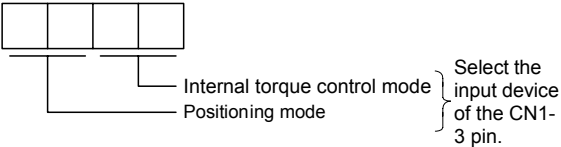
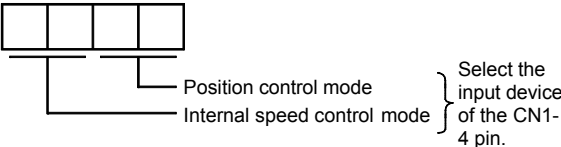
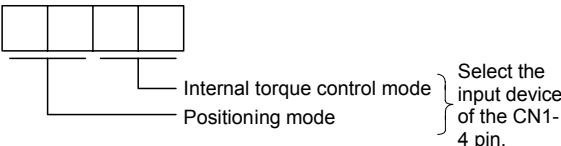
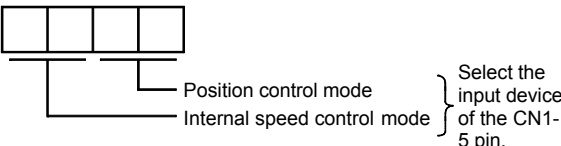
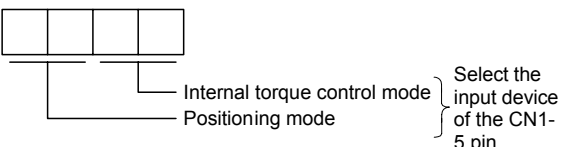
No.	Symbol	Name and function	Initial value	Setting range	Unit	Control mode		
						Position	Internal speed	Internal torque
PD04	*DI1-2	<p>Input signal device selection 1H (CN1-3)</p> <p>Any input signal can be assigned to the CN1-3 pin.</p> <p>The devices that can be assigned and the setting method are the same as in parameter No. PD03.</p> 	2003h	Refer to the name and function field.				<input type="radio"/>
PD05	*DI2-1	<p>Input signal device selection 2L (CN1-4)</p> <p>Any input signal can be assigned to the CN1-4 pin.</p> <p>The devices that can be assigned and the setting method are the same as in parameter No. PD03.</p> 	0202h	Refer to the name and function field.		<input type="radio"/>	<input type="radio"/>	
PD06	*DI2-2	<p>Input signal device selection 2H (CN1-4)</p> <p>Any input signal can be assigned to the CN1-4 pin.</p> <p>The devices that can be assigned and the setting method are the same as in parameter No. PD03.</p> 	0202h	Refer to the name and function field.				<input type="radio"/>
PD07	*DI3-1	<p>Input signal device selection 3L (CN1-5)</p> <p>Any input signal can be assigned to the CN1-5 pin.</p> <p>The devices that can be assigned and the setting method are the same as in parameter No. PD03.</p> 	0D06h	Refer to the name and function field.		<input type="radio"/>	<input type="radio"/>	
PD08	*DI3-2	<p>Input signal device selection 3H (CN1-5)</p> <p>Any input signal can be assigned to the CN1-5 pin.</p> <p>The devices that can be assigned and the setting method are the same as in parameter No. PD03.</p> 	2C0Dh	Refer to the name and function field.				<input type="radio"/>

4. PARAMETERS

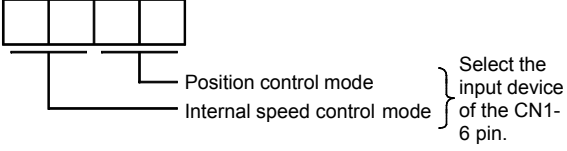
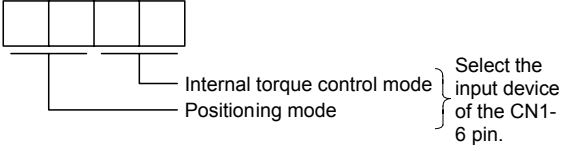
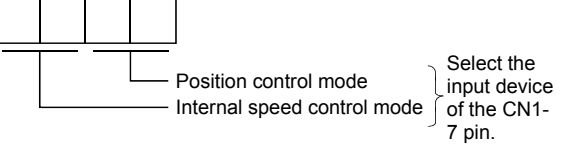
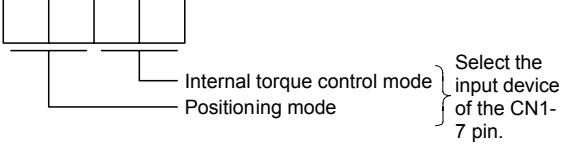
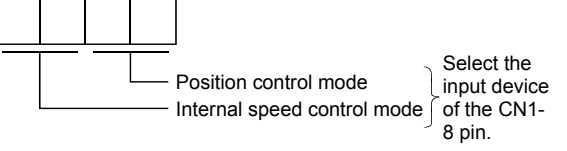
No.	Symbol	Name and function	Initial value	Setting range	Unit	Control mode		
						Position	Internal speed	Internal torque
PD09	*DI4-1	<p>Input signal device selection 4L (CN1-6)</p> <p>Any input signal can be assigned to the CN1-6 pin.</p> <p>The devices that can be assigned and the setting method are the same as in parameter No. PD03.</p> 	070Ah	Refer to the name and function field.		<input type="radio"/>	<input type="radio"/>	
PD10	*DI4-2	<p>Input signal device selection 4H (CN1-6)</p> <p>Any input signal can be assigned to the CN1-6 pin.</p> <p>The devices that can be assigned and the setting method are the same as in parameter No. PD03.</p> 	0707h	Refer to the name and function field.				<input type="radio"/>
PD11	*DI5-1	<p>Input signal device selection 5L (CN1-7)</p> <p>Any input signal can be assigned to the CN1-7 pin.</p> <p>The devices that can be assigned and the setting method are the same as in parameter No. PD03.</p> 	080Bh	Refer to the name and function field.		<input type="radio"/>	<input type="radio"/>	
PD12	*DI5-2	<p>Input signal device selection 5H (CN1-7)</p> <p>Any input signal can be assigned to the CN1-7 pin.</p> <p>The devices that can be assigned and the setting method are the same as in parameter No. PD03.</p> 	0808h	Refer to the name and function field.				<input type="radio"/>
PD13	*DI6-1	<p>Input signal device selection 6L (CN1-8)</p> <p>Any input signal can be assigned to the CN1-8 pin.</p> <p>The devices that can be assigned and the setting method are the same as in parameter No. PD03.</p> <p>If a value other than the initial value is set, EM1 cannot be used.</p> 	0505h	Refer to the name and function field.		<input type="radio"/>	<input type="radio"/>	

4. PARAMETERS

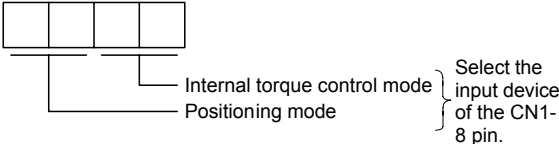
No.	Symbol	Name and function	Initial value	Setting range	Unit	Control mode		
						Position	Internal speed	Internal torque
PD14	*DI6-2	<p>Input signal device selection 6H (CN1-8)</p> <p>Any input signal can be assigned to the CN1-8 pin.</p> <p>The devices that can be assigned and the setting method are the same as in parameter No. PD03.</p> <p>If a value other than the initial value is set, EM1 cannot be used.</p> 	0505h	Refer to the name and function field.				○

4. PARAMETERS

No.	Symbol	Name and function	Initial value	Setting range	Unit	Control mode																																																																																																																																																											
						Position	Internal speed	Internal torque																																																																																																																																																									
PD15	*DO1	<p>Output signal device selection 1 (CN1-9) Any output signal can be assigned to the CN1-9pin. ALM is assigned as the initial value. Note that the device that can be assigned varies depending on the control mode.</p> <table border="1" style="margin-left: 20px;"> <tr> <td style="width: 20px; text-align: center;">0</td> <td style="width: 20px; text-align: center;">0</td> <td style="width: 20px;"></td> <td style="width: 20px;"></td> </tr> </table> <p style="margin-left: 40px;">└─ Select the output device of the CN1-9 pin.</p> <p>The devices that can be assigned in each control mode are indicated by abbreviation in the following table. If any other device is set, it is invalid.</p> <table border="1" style="margin-left: 20px;"> <thead> <tr> <th rowspan="2">Setting</th> <th colspan="4">Control modes (Note 1)</th> </tr> <tr> <th>P</th> <th>S</th> <th>T</th> <th>CP/CL</th> </tr> </thead> <tbody> <tr> <td>00</td> <td>Always OFF</td> <td>Always OFF</td> <td>Always OFF</td> <td>Always OFF</td> </tr> <tr> <td>01</td> <td colspan="4">For manufacturer setting (Note 2)</td> </tr> <tr> <td>02</td> <td>RD</td> <td>RD</td> <td>RD</td> <td>RD</td> </tr> <tr> <td>03</td> <td>ALM</td> <td>ALM</td> <td>ALM</td> <td>ALM</td> </tr> <tr> <td>04</td> <td>INP</td> <td>SA</td> <td>Always OFF</td> <td>INP</td> </tr> <tr> <td>05</td> <td>MBR</td> <td>MBR</td> <td>MBR</td> <td>MBR</td> </tr> <tr> <td>06</td> <td colspan="4">For manufacturer setting (Note 2)</td> </tr> <tr> <td>07</td> <td>TLC</td> <td>TLC</td> <td>VLC</td> <td>TLC</td> </tr> <tr> <td>08</td> <td>WNG</td> <td>WNG</td> <td>WNG</td> <td>WNG</td> </tr> <tr> <td>09</td> <td colspan="4">For manufacturer setting (Note 2)</td> </tr> <tr> <td>0A</td> <td>Always OFF</td> <td>SA</td> <td>Always OFF</td> <td>Always OFF</td> </tr> <tr> <td>0B</td> <td>Always OFF</td> <td>Always OFF</td> <td>VLC</td> <td>Always OFF</td> </tr> <tr> <td>0C</td> <td>ZSP</td> <td>ZSP</td> <td>ZSP</td> <td>ZSP</td> </tr> <tr> <td>0D</td> <td>MTTR</td> <td>MTTR</td> <td>MTTR</td> <td>MTTR</td> </tr> <tr> <td>0E</td> <td colspan="4">For manufacturer setting (Note 2)</td> </tr> <tr> <td>0F</td> <td>CDPS</td> <td>Always OFF</td> <td>Always OFF</td> <td>CDPS</td> </tr> <tr> <td>10 to 1F</td> <td colspan="4">For manufacturer setting (Note 2)</td> </tr> <tr> <td>20</td> <td>Always OFF</td> <td>Always OFF</td> <td>Always OFF</td> <td>CP0 (Note 3)</td> </tr> <tr> <td>21</td> <td>Always OFF</td> <td>Always OFF</td> <td>Always OFF</td> <td>ZP</td> </tr> <tr> <td>22</td> <td>Always OFF</td> <td>Always OFF</td> <td>Always OFF</td> <td>POT</td> </tr> <tr> <td>23</td> <td>Always OFF</td> <td>Always OFF</td> <td>Always OFF</td> <td>PUS</td> </tr> <tr> <td>24</td> <td>Always OFF</td> <td>Always OFF</td> <td>Always OFF</td> <td>MEND</td> </tr> <tr> <td>25</td> <td>Always OFF</td> <td>Always OFF</td> <td>Always OFF</td> <td>PT0 (Note 3)</td> </tr> <tr> <td>26</td> <td>Always OFF</td> <td>Always OFF</td> <td>Always OFF</td> <td>PT1 (Note 3)</td> </tr> <tr> <td>27</td> <td>Always OFF</td> <td>Always OFF</td> <td>Always OFF</td> <td>PT2 (Note 3)</td> </tr> <tr> <td>28</td> <td>Always OFF</td> <td>Always OFF</td> <td>Always OFF</td> <td>OUT1 (Note 4)</td> </tr> <tr> <td>29</td> <td>Always OFF</td> <td>Always OFF</td> <td>Always OFF</td> <td>SOUT (Note 4)</td> </tr> <tr> <td>2A to 3F</td> <td colspan="4">For manufacturer setting (Note 2)</td> </tr> </tbody> </table> <p style="margin-left: 20px;">Note 1. P: Position control mode S: Internal speed control mode T: Internal torque control mode CP: Positioning mode (Point table method) CL: Positioning mode (Program method)</p> <p style="margin-left: 20px;">2. For manufacturer setting. Never set this value. 3. For the program method, it is always OFF. 4. For the point table method, it is always OFF.</p>	0	0			Setting	Control modes (Note 1)				P	S	T	CP/CL	00	Always OFF	Always OFF	Always OFF	Always OFF	01	For manufacturer setting (Note 2)				02	RD	RD	RD	RD	03	ALM	ALM	ALM	ALM	04	INP	SA	Always OFF	INP	05	MBR	MBR	MBR	MBR	06	For manufacturer setting (Note 2)				07	TLC	TLC	VLC	TLC	08	WNG	WNG	WNG	WNG	09	For manufacturer setting (Note 2)				0A	Always OFF	SA	Always OFF	Always OFF	0B	Always OFF	Always OFF	VLC	Always OFF	0C	ZSP	ZSP	ZSP	ZSP	0D	MTTR	MTTR	MTTR	MTTR	0E	For manufacturer setting (Note 2)				0F	CDPS	Always OFF	Always OFF	CDPS	10 to 1F	For manufacturer setting (Note 2)				20	Always OFF	Always OFF	Always OFF	CP0 (Note 3)	21	Always OFF	Always OFF	Always OFF	ZP	22	Always OFF	Always OFF	Always OFF	POT	23	Always OFF	Always OFF	Always OFF	PUS	24	Always OFF	Always OFF	Always OFF	MEND	25	Always OFF	Always OFF	Always OFF	PT0 (Note 3)	26	Always OFF	Always OFF	Always OFF	PT1 (Note 3)	27	Always OFF	Always OFF	Always OFF	PT2 (Note 3)	28	Always OFF	Always OFF	Always OFF	OUT1 (Note 4)	29	Always OFF	Always OFF	Always OFF	SOUT (Note 4)	2A to 3F	For manufacturer setting (Note 2)				0003h	Refer to the name and function field.		○	○	○
0	0																																																																																																																																																																
Setting	Control modes (Note 1)																																																																																																																																																																
	P	S	T	CP/CL																																																																																																																																																													
00	Always OFF	Always OFF	Always OFF	Always OFF																																																																																																																																																													
01	For manufacturer setting (Note 2)																																																																																																																																																																
02	RD	RD	RD	RD																																																																																																																																																													
03	ALM	ALM	ALM	ALM																																																																																																																																																													
04	INP	SA	Always OFF	INP																																																																																																																																																													
05	MBR	MBR	MBR	MBR																																																																																																																																																													
06	For manufacturer setting (Note 2)																																																																																																																																																																
07	TLC	TLC	VLC	TLC																																																																																																																																																													
08	WNG	WNG	WNG	WNG																																																																																																																																																													
09	For manufacturer setting (Note 2)																																																																																																																																																																
0A	Always OFF	SA	Always OFF	Always OFF																																																																																																																																																													
0B	Always OFF	Always OFF	VLC	Always OFF																																																																																																																																																													
0C	ZSP	ZSP	ZSP	ZSP																																																																																																																																																													
0D	MTTR	MTTR	MTTR	MTTR																																																																																																																																																													
0E	For manufacturer setting (Note 2)																																																																																																																																																																
0F	CDPS	Always OFF	Always OFF	CDPS																																																																																																																																																													
10 to 1F	For manufacturer setting (Note 2)																																																																																																																																																																
20	Always OFF	Always OFF	Always OFF	CP0 (Note 3)																																																																																																																																																													
21	Always OFF	Always OFF	Always OFF	ZP																																																																																																																																																													
22	Always OFF	Always OFF	Always OFF	POT																																																																																																																																																													
23	Always OFF	Always OFF	Always OFF	PUS																																																																																																																																																													
24	Always OFF	Always OFF	Always OFF	MEND																																																																																																																																																													
25	Always OFF	Always OFF	Always OFF	PT0 (Note 3)																																																																																																																																																													
26	Always OFF	Always OFF	Always OFF	PT1 (Note 3)																																																																																																																																																													
27	Always OFF	Always OFF	Always OFF	PT2 (Note 3)																																																																																																																																																													
28	Always OFF	Always OFF	Always OFF	OUT1 (Note 4)																																																																																																																																																													
29	Always OFF	Always OFF	Always OFF	SOUT (Note 4)																																																																																																																																																													
2A to 3F	For manufacturer setting (Note 2)																																																																																																																																																																

4. PARAMETERS

No.	Symbol	Name and function	Initial value	Setting range	Unit	Control mode		
						Position	Internal speed	Internal torque
PD16	*DO2	<p>Output signal device selection 2 (CN1-10) Any output signal can be assigned to the CN1-10 pin. INP is assigned as the initial value. The devices that can be assigned and the setting method are the same as in parameter No. PD15.</p> <div style="border: 1px solid black; display: inline-block; padding: 2px;">0 0</div> <p style="margin-left: 40px;">Select the output device of the CN1-10 pin.</p>	0004h	Refer to the name and function field.		○	○	○
PD17	*DO3	<p>Output signal device selection 3 (CN1-11) Any output signal can be assigned to the CN1-11 pin. RD is assigned as the initial value. The devices that can be assigned and the setting method are the same as in parameter No. PD15.</p> <div style="border: 1px solid black; display: inline-block; padding: 2px;">0 0</div> <p style="margin-left: 40px;">Select the output device of the CN1-11 pin.</p>	0002h	Refer to the name and function field.		○	○	○
PD18	*DO4	<p>Output signal device selection 4 (CN1-12) Any output signal can be assigned to the CN1-12 pin. MBR is assigned as the initial value. The devices that can be assigned and the setting method are the same as in parameter No. PD15.</p> <div style="border: 1px solid black; display: inline-block; padding: 2px;">0 0</div> <p style="margin-left: 40px;">Select the output device of the CN1-12 pin.</p>	0005h	Refer to the name and function field.		○	○	○
PD19	*DIF	<p>Input filter setting Select the input filter.</p> <div style="border: 1px solid black; display: inline-block; padding: 2px;">0</div> <p style="margin-left: 40px;">Input filter If external input signal causes chattering due to noise, etc., input filter is used to suppress it. 0: None 1: 1.777[ms] 2: 3.555[ms] 3: 5.333[ms]</p> <p style="margin-left: 40px;">Reset (RES) dedicated filter selection 0: Invalid 1: Valid (50[ms])</p> <p style="margin-left: 40px;">Clear (CR) dedicated filter selection 0: Invalid 1: Valid (50[ms])</p>	0002h	Refer to the name and function field.		○	○	○

4. PARAMETERS

No.	Symbol	Name and function	Initial value	Setting range	Unit	Control mode																										
						Position	Internal speed	Internal torque																								
PD20	*DOP1	<p>Function selection D-1</p> <p>Select the stop processing at forward rotation stroke end (LSP)/reverse rotation stroke end (LSN) OFF, the base circuit status at reset (RES) ON and the operation during tough drive (MTTR).</p> <div style="display: flex; align-items: center;"> <div style="border: 1px solid black; padding: 2px; margin-right: 5px;">0</div> <div style="border: 1px solid black; width: 20px; height: 20px; margin-right: 5px;"></div> <div style="border: 1px solid black; width: 20px; height: 20px; margin-right: 5px;"></div> <div style="border: 1px solid black; width: 20px; height: 20px;"></div> </div> <p>How to make a stop when forward rotation stroke end (LSP)/reverse rotation stroke end (LSN) is OFF. (Refer to Section 4.4.3.) 0: Sudden stop 1: Slow stop</p> <p>Selection of base circuit status at reset (RES) ON 0: Base circuit switched off 1: Base circuit not switched off</p> <p>Operation selection during tough drive (MTTR) 0: MTTR turns ON during the instantaneous power failure tough drive. 1: MTTR turns ON during the overload tough drive or the instantaneous power failure tough drive</p>	0000h	Refer to the name and function field.																												
PD21		<p>For manufacturer setting</p> <p>Do not change this value by any means.</p>	0000h																													
PD22	*DOP3	<p>Function selection D-3</p> <p>Set the clear (CR).</p> <div style="display: flex; align-items: center;"> <div style="border: 1px solid black; padding: 2px; margin-right: 5px;">0</div> <div style="border: 1px solid black; padding: 2px; margin-right: 5px;">0</div> <div style="border: 1px solid black; padding: 2px; margin-right: 5px;">0</div> <div style="border: 1px solid black; width: 20px; height: 20px;"></div> </div> <p>Clear (CR) selection 0: Droop pulses are cleared on the leading edge. 1: While on, droop pulses are always cleared.</p>	0000h	Refer to the name and function field.		○																										
PD23		<p>For manufacturer setting</p> <p>Do not change this value by any means.</p>	0000h																													
PD24	*DOP5	<p>Function selection D-5</p> <p>Select the warning (WNG) outputs.</p> <div style="display: flex; align-items: center;"> <div style="border: 1px solid black; padding: 2px; margin-right: 5px;">0</div> <div style="border: 1px solid black; padding: 2px; margin-right: 5px;">0</div> <div style="border: 1px solid black; padding: 2px; margin-right: 5px;">0</div> <div style="border: 1px solid black; width: 20px; height: 20px;"></div> </div> <p>Selection of output device at warning occurrence Select the warning (WNG) and trouble (ALM) output status at warning occurrence.</p> <table border="1" style="width: 100%; border-collapse: collapse;"> <thead> <tr> <th>Setting</th> <th>(Note) Device status</th> </tr> </thead> <tbody> <tr> <td rowspan="4" style="text-align: center; vertical-align: middle;">0</td> <td>WNG 1</td> <td></td> </tr> <tr> <td>WNG 0</td> <td></td> </tr> <tr> <td>ALM 1</td> <td></td> </tr> <tr> <td>ALM 0</td> <td></td> </tr> <tr> <td colspan="2" style="text-align: center;">Warning occurrence</td> </tr> <tr> <td rowspan="4" style="text-align: center; vertical-align: middle;">1</td> <td>WNG 1</td> <td></td> </tr> <tr> <td>WNG 0</td> <td></td> </tr> <tr> <td>ALM 1</td> <td></td> </tr> <tr> <td>ALM 0</td> <td></td> </tr> <tr> <td colspan="2" style="text-align: center;">Warning occurrence</td> </tr> </tbody> </table> <p>Note. 0: off 1: on</p>	Setting	(Note) Device status	0	WNG 1		WNG 0		ALM 1		ALM 0		Warning occurrence		1	WNG 1		WNG 0		ALM 1		ALM 0		Warning occurrence		0000h	Refer to the name and function field.		○	○	○
Setting	(Note) Device status																															
0	WNG 1																															
	WNG 0																															
	ALM 1																															
	ALM 0																															
Warning occurrence																																
1	WNG 1																															
	WNG 0																															
	ALM 1																															
	ALM 0																															
Warning occurrence																																

4. PARAMETERS

No.	Symbol	Name and function	Initial value	Setting range	Unit	Control mode		
						Position	Internal speed	Internal torque
PD25	/	For manufacturer setting	0000h	/	/	/	/	/
PD26		Do not change this value by any means.	0000h					

4.4.3 Using forward/reverse rotation stroke end to change the stopping pattern

In the initial value, the servo motor makes a sudden stop when the forward/reverse rotation stroke end turns OFF. A slow stop can be made by changing parameter No. PD20 setting.

Parameter No. PD20 setting	Stopping method
□□□ 0 (initial value)	<p>Sudden stop</p> <p>Position control mode : The servo motor stops by clearing the droop pulses.</p> <p>Internal speed control mode : The servo motor stops when the deceleration time constant is zero.</p>
□□□ 1	<p>Slow stop</p> <p>Position control mode : The servo motor decelerates to a stop in accordance with parameter No. PB03 setting.</p> <p>Internal speed control mode : The servo motor decelerates to a stop in accordance with parameter No. PC02 setting.</p>

5. DISPLAY AND OPERATION

5. DISPLAY AND OPERATION SECTIONS

POINT
<ul style="list-style-type: none"> Positioning mode is supported by servo amplifier with software version B0 or later.

5.1 Overview

MR-JN-A servo amplifier has a display section (3-digit, 7-segment LED), operation section (4 pushbuttons) and a one-touch tuning button for servo amplifier status display, alarm display, parameter and point table setting, etc.

The operation section and display data are described below.

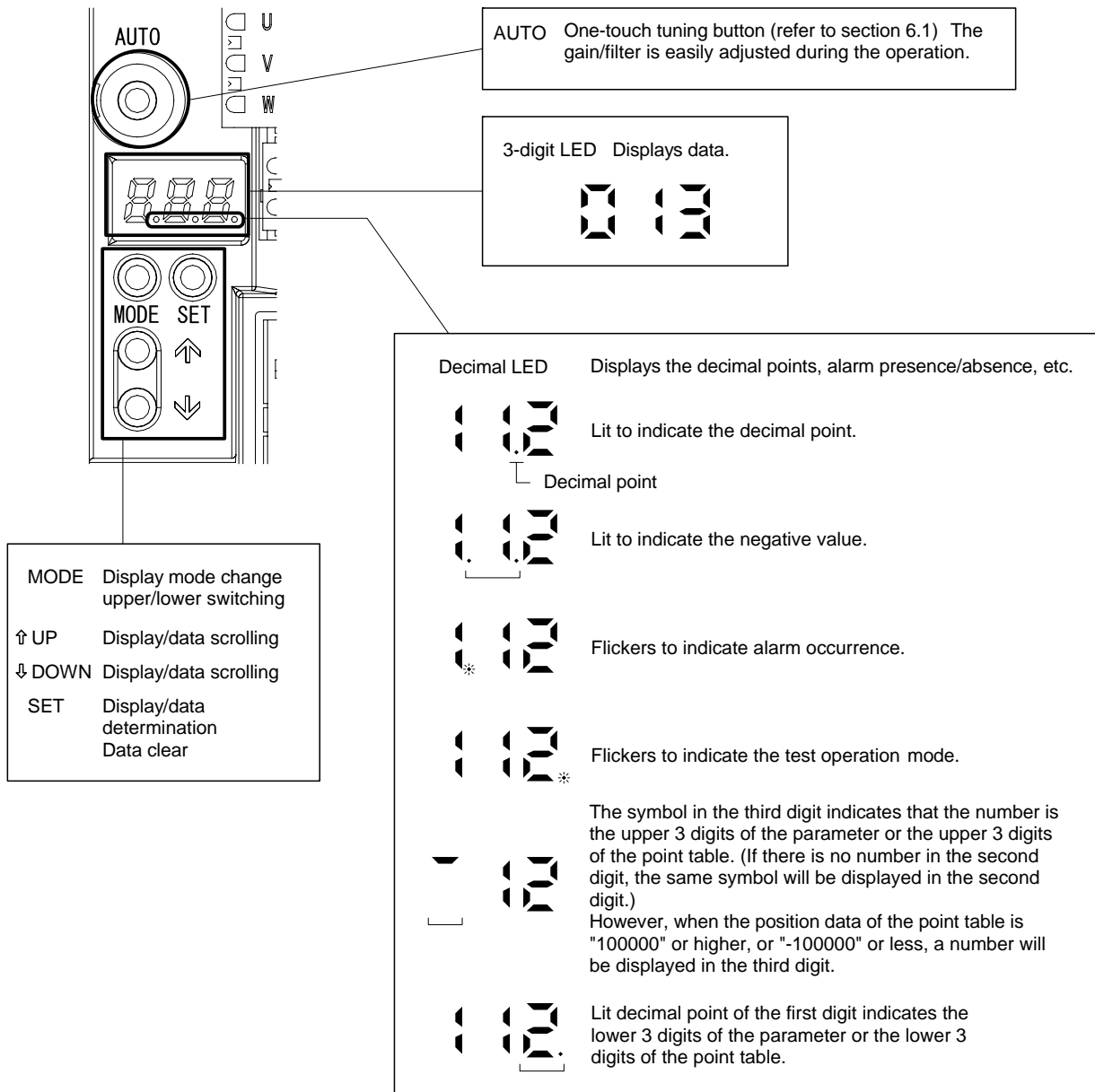

5. DISPLAY AND OPERATION SECTIONS

5.2 Display sequence

Press the "MODE" button once to shift to the next display mode. Refer to section 5.3 and later for the description of the corresponding display mode.

To refer to or set the gain/filter parameters, extension setting parameters, I/O setting parameters and positioning setting parameters, make them valid with parameter No. PA19 (parameter writing inhibit).

Display mode transition	Initial screen	Function	Reference
<pre> graph TD A([Status display]) --> B([Diagnosis]) B --> C([Alarm]) C --> D([Point table]) D --> E([Basic setting parameters]) E --> F([Gain/filter parameters]) F --> G([Extension setting parameters]) G --> H([I/O setting parameters]) H --> I([Positioning setting parameters]) I -- MODE button --> A </pre>		Servo status display. [L] appears at power-on. (Note)	Section 5.3
		Sequence display, external signal display, forced output of signal (DO), test operation, software version display, servo motor series ID display, servo motor type ID display, servo motor encoder ID display.	Section 5.4
		Current alarm display, alarm history display, the number of tough drive display, parameter error No. display.	Section 5.5
		Display and setting of point table data.	Section 5.6
		Display and setting of basic setting parameters.	Section 5.7
		Display and setting of gain/filter parameters.	
		Display and setting of extension setting parameters.	
		Display and setting of I/O setting parameters.	
		Display and setting of positioning setting parameters.	

Note. When the axis name is set to the servo amplifier using MR Configurator, the axis name is displayed and the servo status is then displayed.

5. DISPLAY AND OPERATION SECTIONS

5.3 Status display

The servo status during operation is shown on the 3-digit, 7-segment LED display. Press the "UP" or the "DOWN" button to change the display data as desired. When the required data is selected, the corresponding symbol appears. Press the "SET" button to display the data. At power-on, however, the data appears either after the symbol of the status display for the respective control mode (refer to the following table) has been shown for 2[s], or after pressing the "MODE", "UP" or "DOWN" button.

Control mode	Status display at power-on
Position	Cumulative feedback pulses by the pulse
Position/internal speed	Cumulative feedback pulses by the pulse/servo motor speed in 10r/min
Internal speed	Servo motor speed in 10r/min
Internal speed/internal torque	Servo motor speed in 10r/min/instantaneous torque
Internal torque	Instantaneous torque
Internal torque/position	Instantaneous torque/cumulative feedback pulses by the pulse
Positioning	Current position in 10^{STM} μm unit

The servo amplifier display shows the data of 26 items such as the motor speed in a 3-digit display.

5. DISPLAY AND OPERATION SECTIONS

5.3.1 Display transition

After selecting the status display mode by the "MODE" button, pressing the "UP" or the "DOWN" button changes the display as shown below.

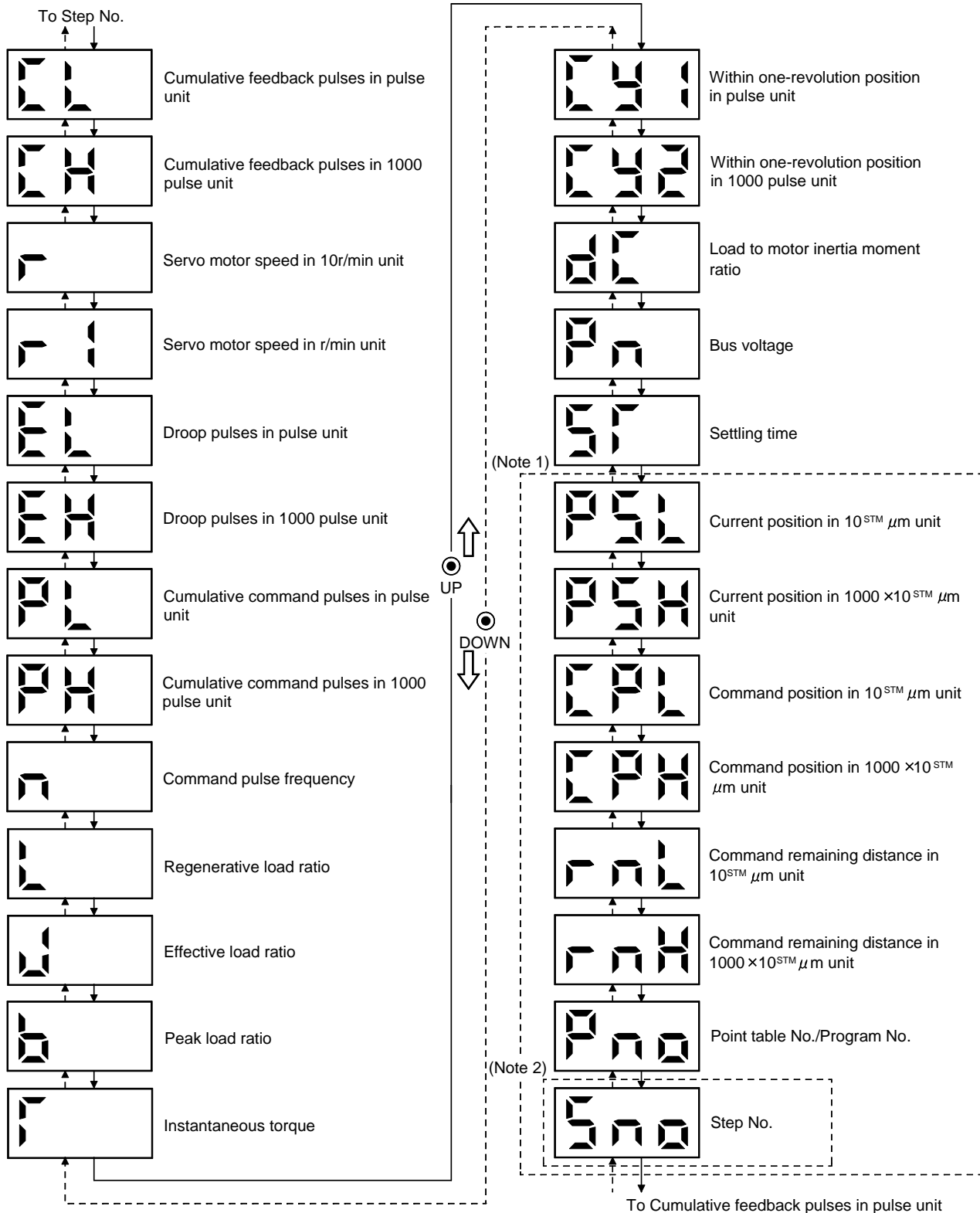

Note 1. It can be displayed in the positioning mode (point table method and program method).

2. It can be displayed in the positioning mode (program method).

5. DISPLAY AND OPERATION SECTIONS

5.3.2 Display examples

POINT
<ul style="list-style-type: none"> The following is priority order of the status display when two or more decimal points need to be displayed. <ol style="list-style-type: none"> Alarm occurrence, test operation Negative values

The following table lists display examples.

Item	Status	Displayed data
		Servo amplifier display
Servo motor speed in 10r/min unit	Forward rotation at 2500r/min	
	Reverse rotation at 3000r/min	<p>Reverse rotation is indicated by the lit decimal points in the upper two digits.</p>
Servo motor speed in r/min unit	Forward rotation at 250r/min	
	Reverse rotation at 300r/min	<p>Reverse rotation is indicated by the lit decimal points in the upper two digits.</p>

5. DISPLAY AND OPERATION SECTIONS

Item	Status		Displayed data
			Servo amplifier display
Cumulative feedback pulses	720000pulse	Pulse unit	
		1000 pulse unit	
	-680000pulse	Pulse unit	 Negative value is indicated by the lit decimal points in the upper two digits.
		1000 pulse unit	 Negative value is indicated by the lit decimal points in the upper two digits.
Load to motor inertia moment ratio	15 Multiplier		

5. DISPLAY AND OPERATION SECTIONS

5.3.3 Status display list

POINT
▪ Refer to appendix 4 for the measurement point.

The following table lists the servo statuses that may be shown.





Name	Symbol	Unit	Description	Display range
Cumulative feedback pulses in pulse unit	CL	pulse	Feedback pulses from the servo motor encoder are counted and displayed. Press the "SET" button to reset the display value to zero.	-999 to 999
Cumulative feedback pulses in 1000 pulse unit	CH	1000pulse	Negative values are indicated by the lit decimal points in the upper two digits.	-999 to 999
Servo motor speed in 10r/min unit	r	10r/min	The servo motor speed is displayed in 10r/min unit.	-540 to 540
Servo motor speed in r/min unit	r1	r/min	The servo motor speed is displayed in r/min unit.	-999 to 999
Droop pulses in pulse unit	EL	pulse	The number of droop pulses in the deviation counter is displayed. When the servo motor is rotating in the reverse direction, the decimal points in the upper two digits are lit.	-999 to 999
Droop pulses in 1000 pulse unit	EH	1000pulse	The displayed number of pulses is in the same pulse unit as the servo motor encoder resolution.	-999 to 999
Cumulative command pulses in pulse unit	PL	pulse	The position command input pulses are counted and displayed. As the value displayed is not yet multiplied by the electronic gear (CMX/CDV), it may not match the indication of the cumulative feedback pulses.	-999 to 999
Cumulative command pulses in 1000 pulse unit	PH	1000pulse	Press the "SET" button to reset the display value to zero. Reverse rotation is indicated by the lit decimal points in the upper two digits.	-999 to 999
Command pulse frequency	n	kpps	The frequency of the position command input pulses is displayed. The value displayed is not multiplied by the electronic gear (CMX/CDV). The value in excess of ± 999 can be counted up to ± 1500 . However, the counter shows only the lower three digits since the servo amplifier display is three digits.	-999 to 999
Regenerative load ratio	L	%	The ratio of regenerative power to permissible regenerative power is displayed in %.	0 to 100
Effective load ratio	J	%	The continuous effective load current is displayed. The effective value in the past 15[s] is displayed relative to the rated current of 100%.	0 to 300
Peak load ratio	b	%	The maximum current is displayed. The highest value in the past 15[s] is displayed relative to the rated current of 100%.	0 to 400
Instantaneous torque	T	%	Torque that occurred instantaneously is displayed. The value of the torque that occurred is displayed in real time relative to the rate torque of 100%.	0 to 400
Within one-revolution position in pulse unit	Cy1	pulse	Position within one revolution is displayed in encoder pulses. The value returns to 0 when it exceeds the maximum number of pulses.	0 to 999
Within one-revolution position in 1000 pulse unit	Cy2	1000pulse	The value is incremented in the CCW direction of rotation. The value is decremented in the CW direction of rotation.	0 to 999
Load to motor inertia moment ratio	dC	Multiplier ($\times 10^{-1}$)	The estimation value of load to motor inertia moment ratio to the servo motor shaft inertia moment is displayed.	0 to 300
Bus voltage	Pn		Status of the bus voltage is displayed in five steps. 5: Overvoltage (About 400V or more) 4: High voltage (About 375V or more) 3: Normal 2: Low voltage (About 200V or less) 1: Undervoltage (About 160V or less)	Refer to the contents.
Settling time	ST	ms	Settling time is displayed. The value in excess of 999 can be counted. However, the counter shows only the lower three digits since the servo amplifier display is three digits.	0 to 999

5. DISPLAY AND OPERATION SECTIONS

5.4 Diagnostic mode

Name		Display	Description
Sequence			Not ready. Indicates that the servo amplifier is being initialized or an alarm has occurred.
			Ready. Indicates that the servo was switched on after completion of initialization and the servo amplifier is ready to operate.
External I/O signal display		Refer to section 5.8.	Indicates the ON-OFF states of the external I/O signals. The upper segments correspond to the input signals and the lower segments to the output signals. Lit: ON Extinguished: OFF
Drive recorder valid/invalid display			Drive recorder is valid. (During operation)
			Drive recorder is invalid. (During stop)
Output signal (DO) forced output			The digital output signal can be forced on/off. For details, refer to section 5.9.
Test operation mode	JOG operation		JOG operation can be performed when there is no command from the external command device. For details, refer to section 5.10.2.
	Positioning operation		With no command given from the external command device, positioning operation can be executed once. MR Configurator is required for positioning operation. For details, refer to section 5.10.3.
	Motor-less operation		Without connection of the servo motor, the servo amplifier provides output signals and displays the status as if the servo motor is running actually in response to the input device. For details, refer to section 5.10.4.
	Forced tough drive operation		Overload tough drive can be forced even in the normal status. For details, refer to section 5.10.5.
	Single-step feed		Indicates the operation following the set point table No. MR Configurator is required for single-step feed. For details, refer to section 13.10.
Software version low			Indicates the version of the software.



5. DISPLAY AND OPERATION SECTIONS

Name	Display	Description
Software version high		Indicates the lower two digits of the system number of the software. Three digits are displayed by pressing the "SET" button.
Servo motor series ID		Series ID of the servo motor currently connected will be displayed by pressing the "SET" button. For details, refer to App. 2.
Servo motor type ID		Type ID of the servo motor currently connected will be displayed by pressing the "SET" button. For details, refer to App. 2.
Servo motor Encoder ID		Encoder ID of the servo motor currently connected will be displayed by pressing the "SET" button. For details, refer to App. 2.
For manufacturer setting		



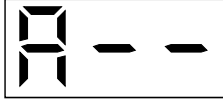
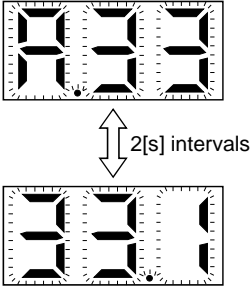
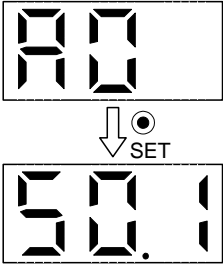
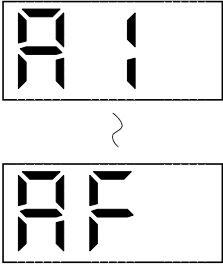

5. DISPLAY AND OPERATION SECTIONS

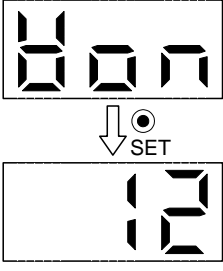
5.5 Alarm mode

The current alarm, the past alarm history, the number of tough drive, the number of drive recorder record times, and the parameter error No. are displayed. The lower 2 digits on the display indicate the alarm number that has occurred or the parameter number in error.

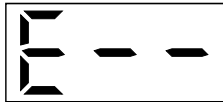
Name	Display	Description
Current alarm		Indicates no occurrence of an alarm.
		Indicates the occurrence of alarm 33 (overvoltage: detail 1). Flickers at occurrence of the alarm. Alarm No. and detail No. are displayed alternately in 2[s] intervals.
Alarm history		Indicates the last alarm. If the last alarm is 50 (overload: detail 1), alarm No. 50 (with detail No.) is displayed while holding down the "SET" button.
		Indicates in hexadecimal for the second to the sixteenth alarm in the past as shown on the left. The alarm No. (with detail No.) is displayed while holding down the "SET" button.
The number of tough drive		Indicates the number of tough drive from 0 to 99. The number of tough drive can be cleared by setting parameter No. PC11 (alarm history clear) to "□□1".
The number of drive recorder record times		Indicates the number of drive recorder record times. The number of times is displayed while holding down the "SET" button.

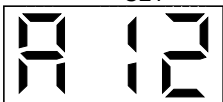
5. DISPLAY AND OPERATION SECTIONS

Name	Display	Description
Parameter error No.		Indicates no occurrence of alarm 37 (parameter error).
	 	Indicates the parameter error No. If an error occurs in parameter No. PA12, "A12" is displayed while holding down the "SET" button.
	 	Indicates the point table error No. If an error occurs in acceleration time constant of the point table No.1, "1A" is displayed while holding down the "SET" button. The first digit in the display refers to the followings. P: Position data d: Servo motor speed A: Acceleration time constant b: Deceleration time constant n: Dwell H: Auxiliary function

Functions at occurrence of an alarm

- (1) Any mode screen displays the current alarm.
- (2) Even during alarm occurrence, the other screen can be viewed by pressing the button in the operation area.
At this time, the decimal point in the third digit remains flickering.
- (3) For any alarm, remove its cause and clear it in any of the following methods (for clearable alarms, refer to section 8.1)
 - (a) Switch power OFF, then ON.
 - (b) Press the "SET" button on the current alarm screen.
 - (c) Turn on the alarm reset (RES).
- (4) Use parameter No. PC11 to clear the alarm history.
- (5) When the servo-on (SON) is off after clearing the alarm history, the display shifts to the status display screen at power-on.
When the servo-on (SON) is on, the following screen is displayed on the current alarm.

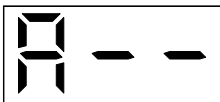

- (6) Press the "UP" or the "DOWN" button to move to the next history.

5. DISPLAY AND OPERATION SECTIONS

5.6 Point table mode

In the positioning mode (point table method), the position data, the servo motor speed, the acceleration time constant, the deceleration time constant, dwell, and the auxiliary function can be set.

5.6.1 Point table transition

After selecting the point table mode with the "MODE" button, pressing the "UP" or the "DOWN" button changes the display as shown below.

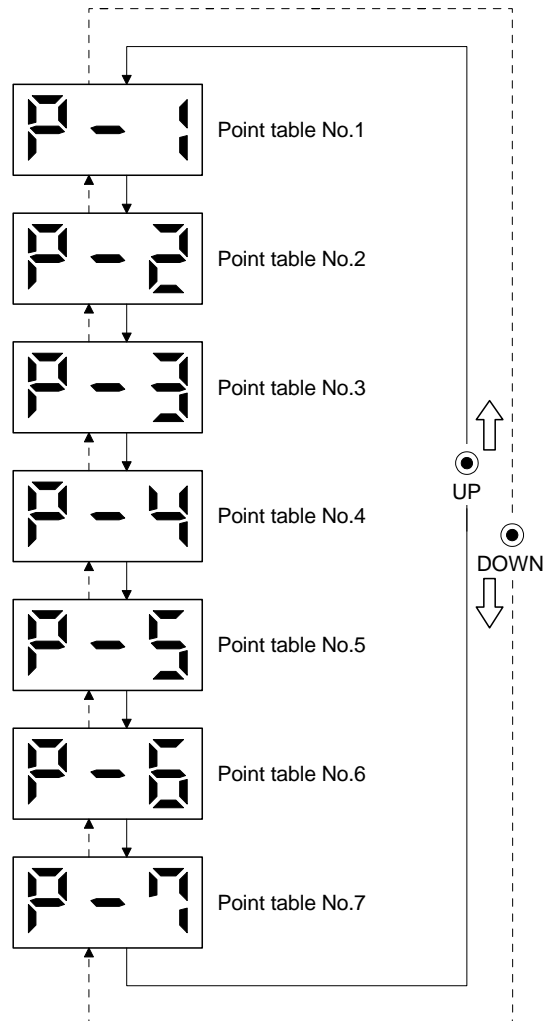

5. DISPLAY AND OPERATION SECTIONS

5.6.2 Point table mode setting screen sequence

In the point table mode, pressing the "SET" button changes the screen as shown below. Press the "UP" or the "DOWN" button to move to the next screen.

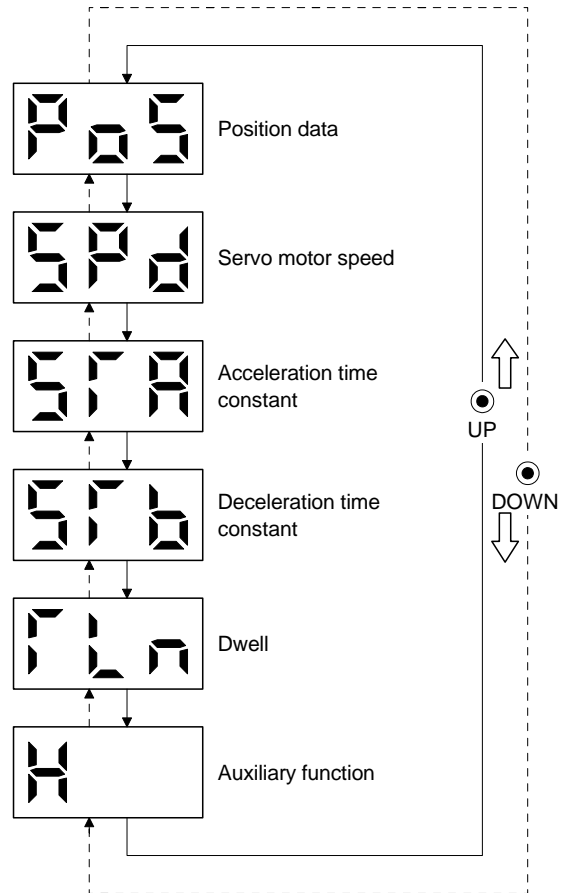

5. DISPLAY AND OPERATION SECTIONS

5.6.3 Operation example

POINT
<ul style="list-style-type: none"> When the set value of a specified point table is changed and entered, the entered set value is displayed. The set value can be cancelled by pressing the "MODE" button for 2[s] or longer immediately after entering the value. Then, the previous set value is displayed.

(1) Setting of 3 or less digits

The following example shows the operation procedure performed after power-on to set the auxiliary function of the point table No.1 to "1".

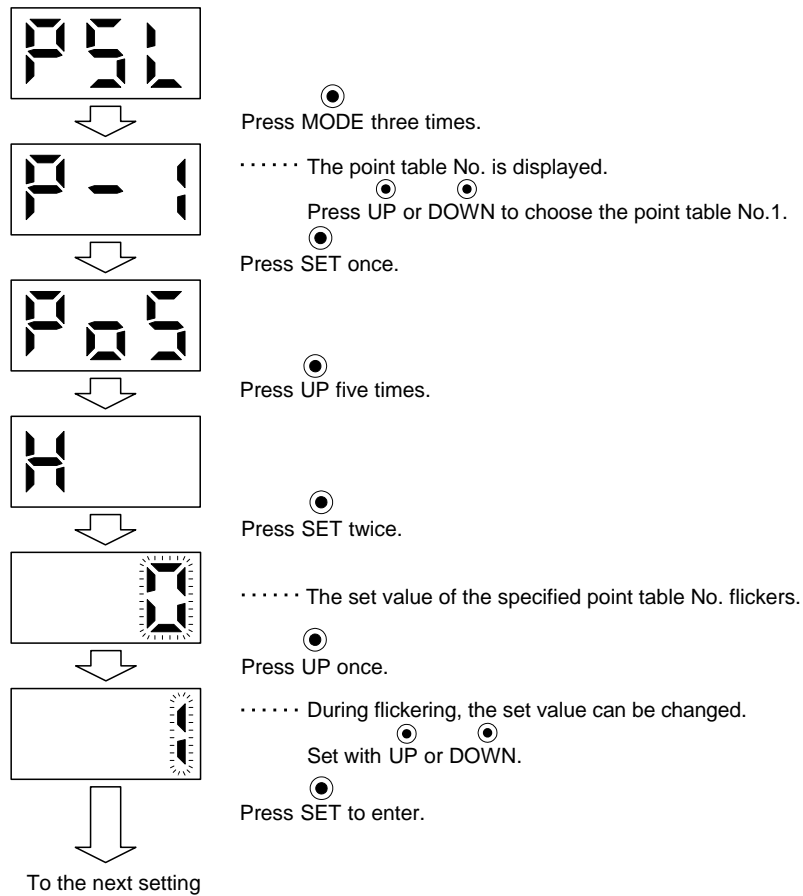

After setting (1), to shift to other items of the same point table No., press the "UP" or the "DOWN" button.
To shift to the next point table No., press the "MODE" button.

5. DISPLAY AND OPERATION SECTIONS

(2) Setting of 4 or more digits

The following example gives the operation procedure to change the position data of the point table No.1 to "123456".

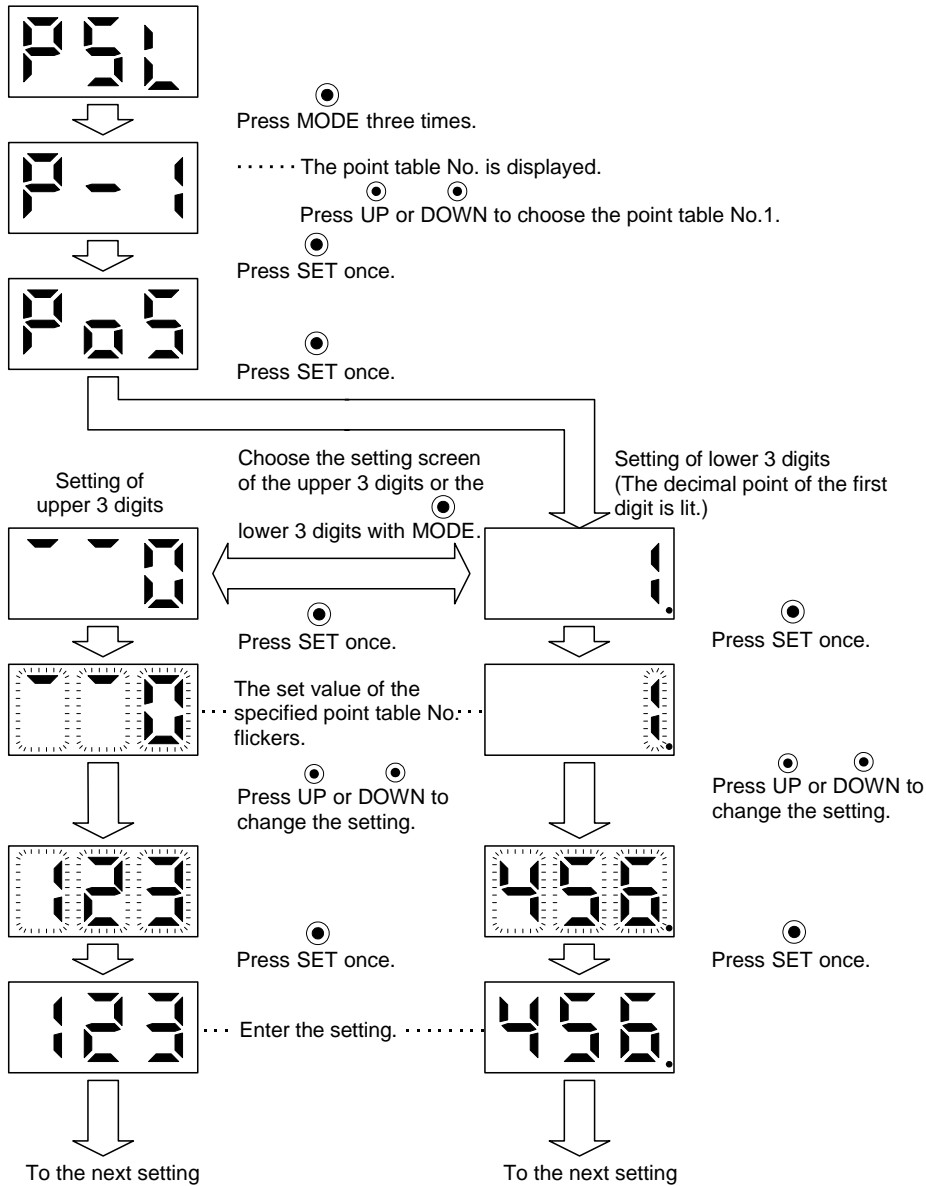

After setting (2), to shift to the setting of higher or lower 3 digits in the same point table No., press the "MODE" button.

To shift to other items of the same point table No., press the "UP" or the "DOWN" button.

To shift to the next point table No., press the "MODE" button after shifting to other items of the same point table No. by pressing the "UP" or "DOWN" button.

5. DISPLAY AND OPERATION SECTIONS

5.7 Parameter mode

5.7.1 Parameter mode transition

After choosing the corresponding parameter mode with the "MODE" button, pressing the "UP" or the "DOWN" button changes the display as shown below.

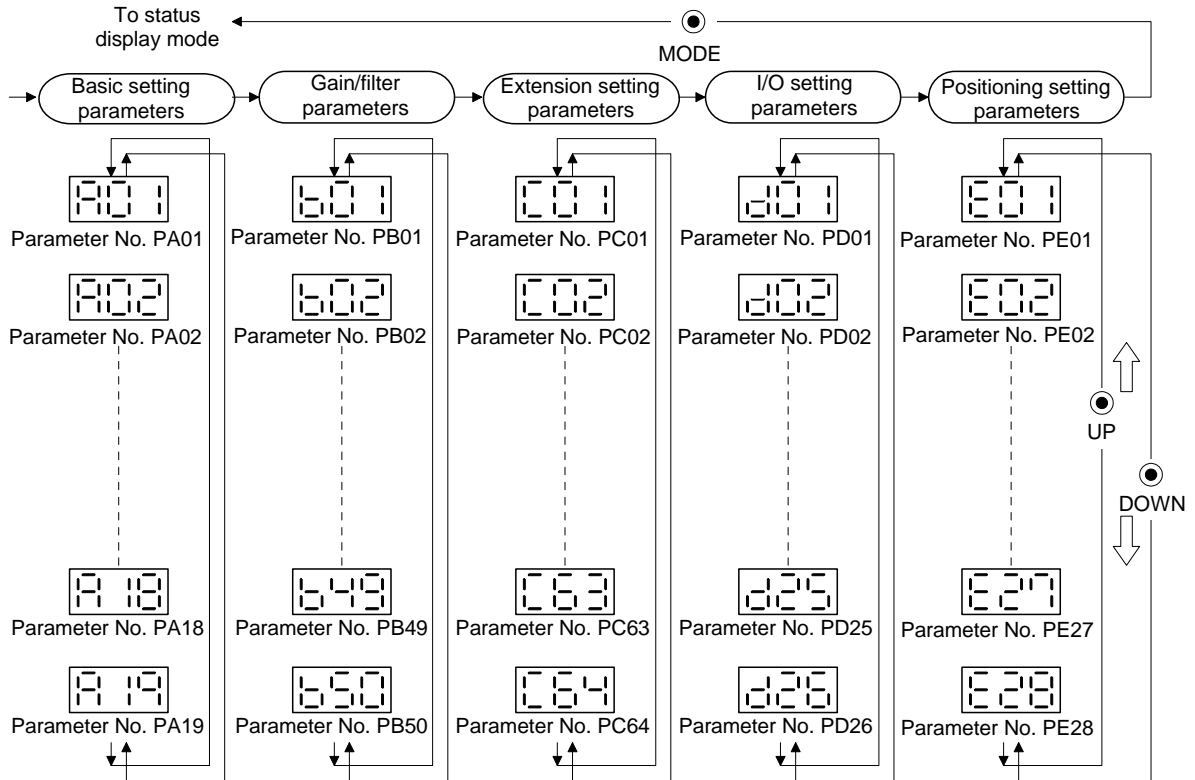

5. DISPLAY AND OPERATION SECTIONS

5.7.2 Operation example

POINT
▪ When the set value of a specified parameter is changed and entered, the entered set value is displayed. The set value can be cancelled by pressing the "MODE" button for 2[s] or longer immediately after entering the value. Then, the previous set value is displayed.

(1) Parameter of 3 or less digits

The following example shows the operation procedure performed after power-on to change the control mode (parameter No. PA01) to the internal speed control mode. Press "MODE" to switch to the basic setting parameter screen.

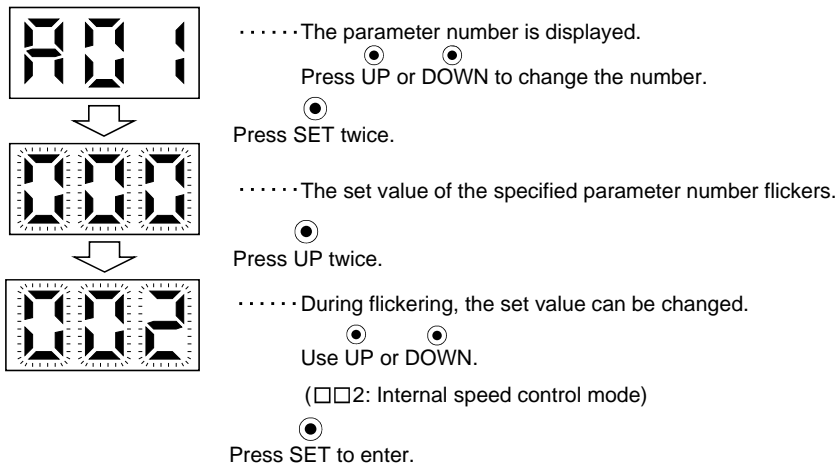

To shift to the next parameter, press the "UP" or the "DOWN" button.

When changing parameter No. PA01 setting, change its set value, then switch power off once and switch it on again to make the new value valid.

5. DISPLAY AND OPERATION SECTIONS

(2) Parameter of 4 or more digits

The following example gives the operation procedure to change the electronic gear numerator (command pulse multiplication numerator) (parameter No. PA06) to "12345".

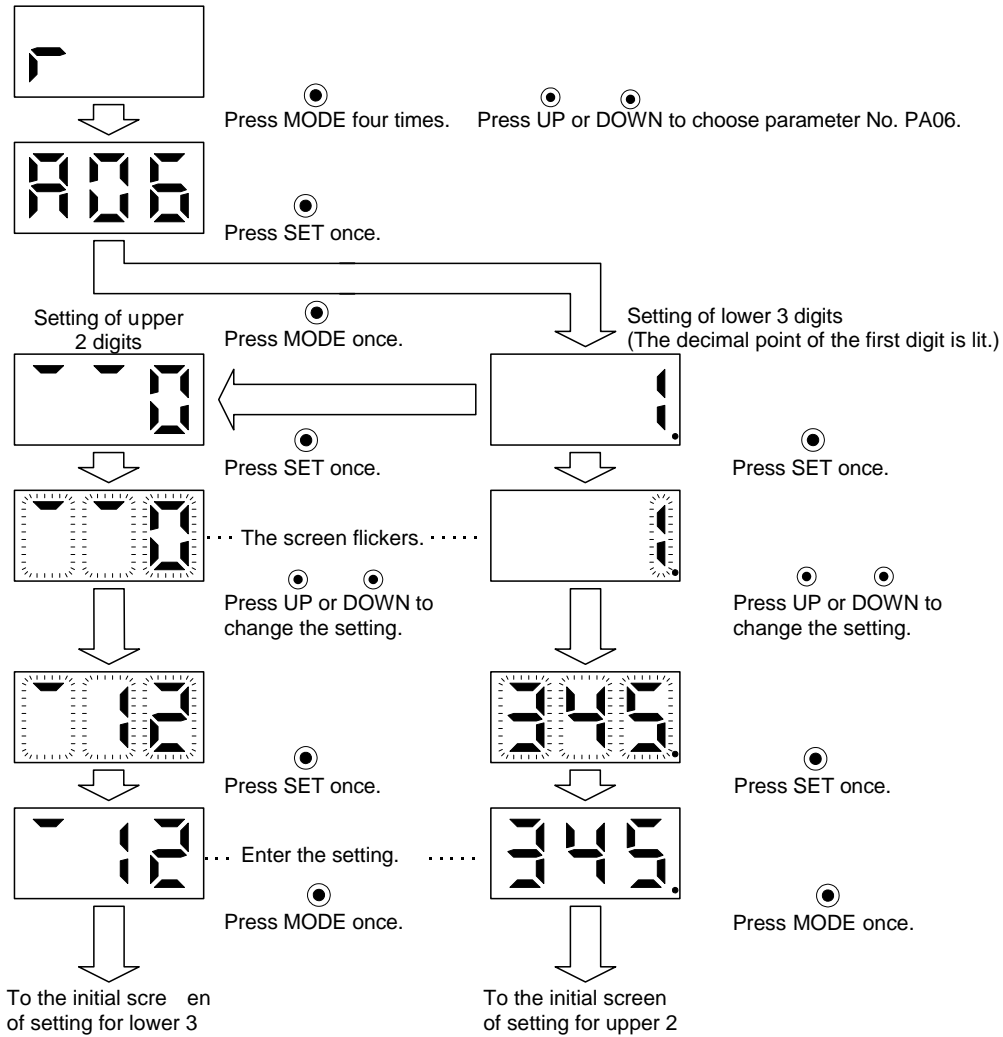

To proceed to the next parameter, press the "UP" or "DOWN" button.

5. DISPLAY AND OPERATION SECTIONS

5.8 External I/O signal display

The ON/OFF states of the digital I/O signals connected to the servo amplifier can be confirmed.

(1) Operation

Call the display screen shown after power-on. Using the "MODE" button, show the diagnostic screen.

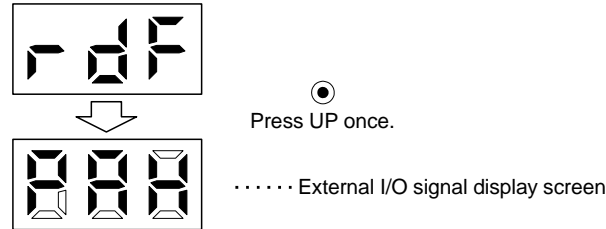

(2) Display definition

The 7-segment LED segments and CN1 connector pins correspond as shown below.

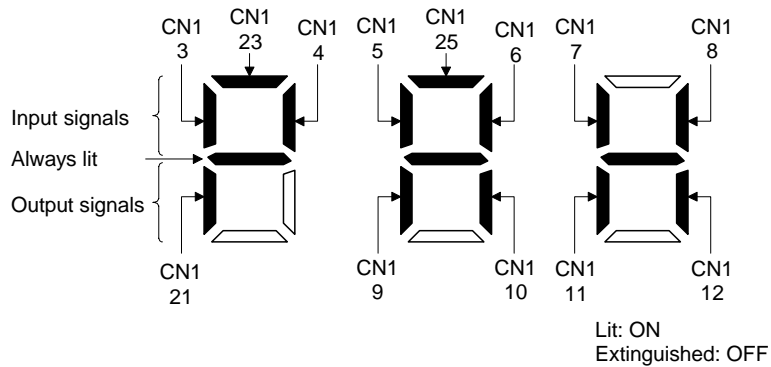

The LED segment corresponding to the pin is lit to indicate ON, and is extinguished to indicate OFF. The signals corresponding to the pins in the respective control modes are indicated below.

5. DISPLAY AND OPERATION SECTIONS

(a) Control modes and I/O signals

Connector	Pin No.	Signal input/output (Note 1) I/O	(Note 2) Symbols of I/O signals in control modes							Related parameter
			P	P/S	S	S/T	T	T/P	CP/CL	
CN1	3	I	RES	RES	RES	RES	RES	RES	MD0	PD03 • PD04
	4	I	SON	SON	SON	SON	SON	SON	SON	PD05 • PD06
	5	I	CR	CR/SP1	SP1	SP1/SP1	SP1	SP1/CR	DI0	PD07 • PD08
	6	I	LSP	LSP/ST1	ST1	ST1/RS2	RS2	RS2/LSP	ST1	PD09 • PD10
	7	I	LSN	LSN/ST2	ST2	ST2/RS1	RS1	RS1/LSN	ST2	PD11 • PD12
	8	I	EM1	EM1	EM1	EM1	EM1	EM1	EM1	PD13 • PD14
	9	O	ALM	ALM	ALM	ALM	ALM	ALM	ALM	PD15
	10	O	INP	INP/SA	SA	SA/-		-/INP	INP	PD16
	11	O	RD	RD	RD	RD	RD	RD	RD	PD17
	12	O	MBR	MBR	MBR	MBR	MBR	MBR	MBR	PD18
	21	O	OP	OP	OP	OP	OP	OP	OP	
	23	I							DI1	PD02
	25	I							DOG	PD02

Note 1. I: Input signal, O: Output signal

2. P: Position control mode, S: Internal speed control mode, T: Internal torque control mode,
P/S: Position/internal speed control change mode, S/T: Internal speed/internal torque control change mode,
T/P: Internal torque/position control change mode
CP: Positioning mode (Point table method), CL: Positioning mode (Program method)

(b) Symbol and signal names

Symbol	Signal name	Symbol	Signal name
SON	Servo-on	RD	Ready
RES	Reset	ALM	Trouble
PC	Proportion control	INP	In-position
EM1	Forced stop	SA	Speed reached
CR	Clear	MBR	Electromagnetic brake interlock
ST1	Forward rotation start	TLC	Limiting torque
ST2	Reverse rotation start	VLC	Limiting speed
RS1	Forward rotation selection	WNG	Warning
RS2	Reverse rotation selection	ZSP	Zero speed
TL1	Internal torque limit selection	MTRR	During tough drive
LSP	Forward rotation stroke end	CDPS	During variable gain selection
LSN	Reverse rotation stroke end	ZP	Home position return completion
SP1	Speed selection 1	PUS	Temporary stop
SP2	Speed selection 2	MEND	Travel completion
SP3	Speed selection 3	CP0	Rough match
LOP	Control change	POT	Position range output
CDP	Gain changing selection	PT0	Point table No. output 1
DOG	Proximity dog	PT1	Point table No. output 2
MD0	Automatic/Manual selection	PT2	Point table No. output 3
TSTP	Temporary stop/Restart	OUT1	Program output 1
DI0	Point table No./Program No. selection 1	SOUT	SYNC synchronous output
DI1	Point table No./Program No. selection 2	OP	Encoder Z-phase pulse (open collector)
DI2	Point table No./Program No. selection 3		
PI1	Program input 1		

5. DISPLAY AND OPERATION SECTIONS

(3) Display data at initial values

(a) Position control mode

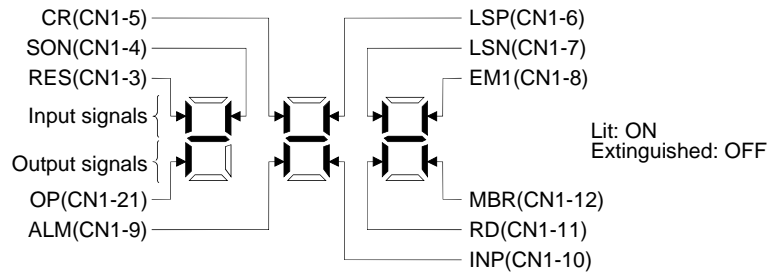

(b) Internal speed control mode

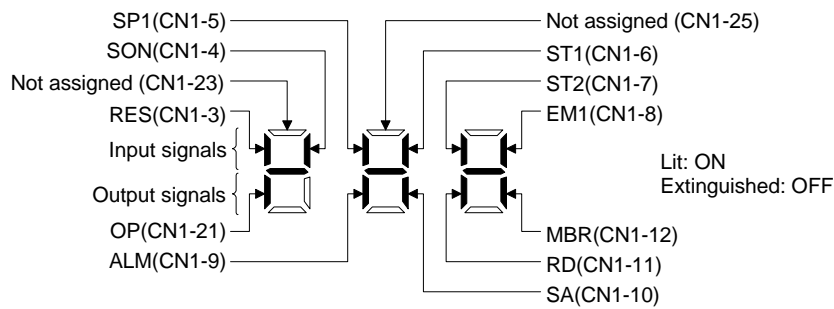

(c) Internal torque control mode

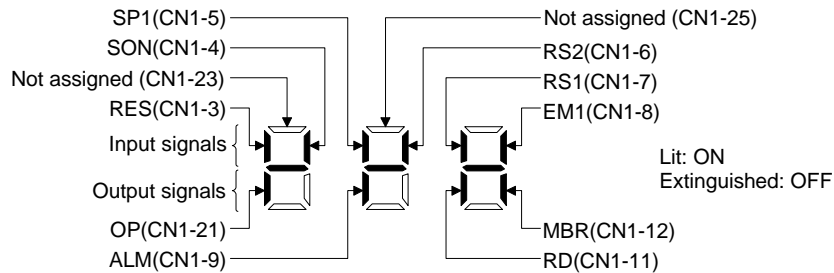

(d) Positioning mode

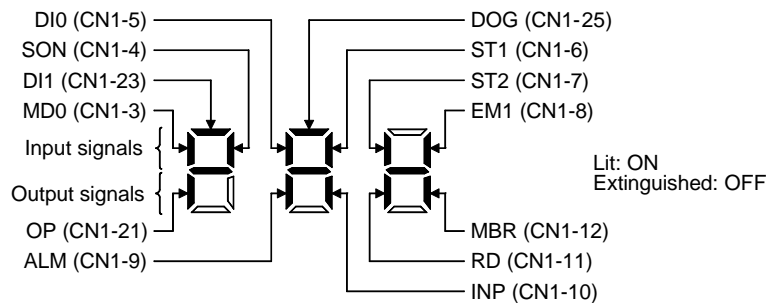

5. DISPLAY AND OPERATION SECTIONS

5.9 Output signal (DO) forced output

POINT
<ul style="list-style-type: none"> When the servo system is used in a vertical lift application, turning on the electromagnetic brake interlock (MBR) with DO forced output after assigning it to connector CN1 will release the electromagnetic brake, causing a drop. Take drop preventive measures on the machine side.

The output signal can be forced on/off independently of the servo status. This function is used for output signal wiring check, etc. This operation must be performed in the servo off state by turning off the servo-on (SON).

Operation

After power-on, change the display to the diagnostic screen using the "MODE" button.

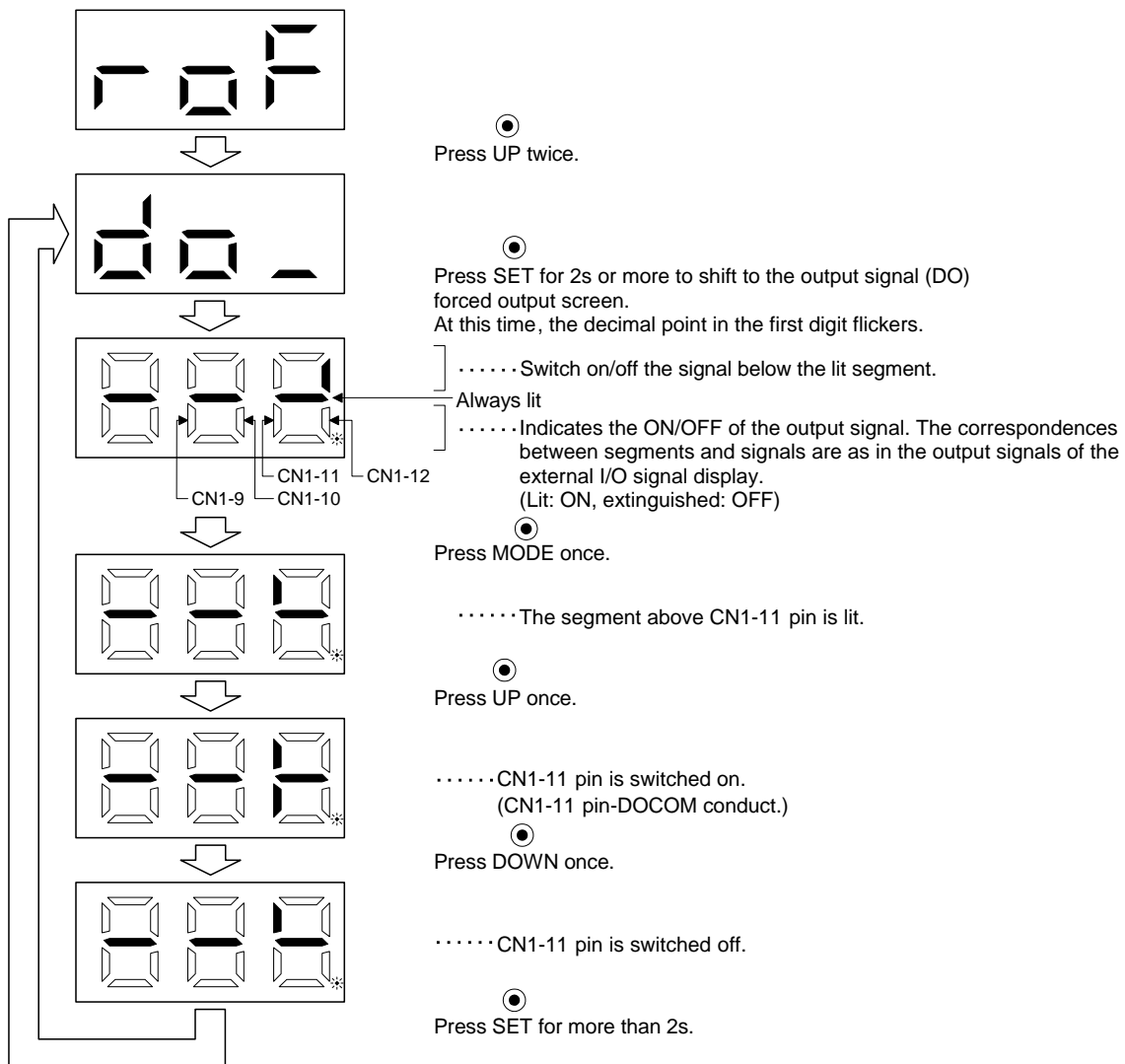

5. DISPLAY AND OPERATION SECTIONS

5.10 Test operation mode



CAUTION

- The test operation mode is designed to confirm servo operation. Do not use it for actual operation.
- If any abnormal operation has occurred, stop the operation using the forced stop (EM1) signal.

POINT

- MR Configurator is required to perform positioning operation.
- Test operation cannot be performed if the servo-on (SON) is not turned OFF.
- When the test operation is performed in the positioning mode, turn off the power of the servo amplifier once to shift to the normal operation mode.

5.10.1 Mode change

After power-on, change the display to the diagnostic screen using the "MODE" button. Select JOG operation/motor-less operation/forced tough drive operation in the following procedure.

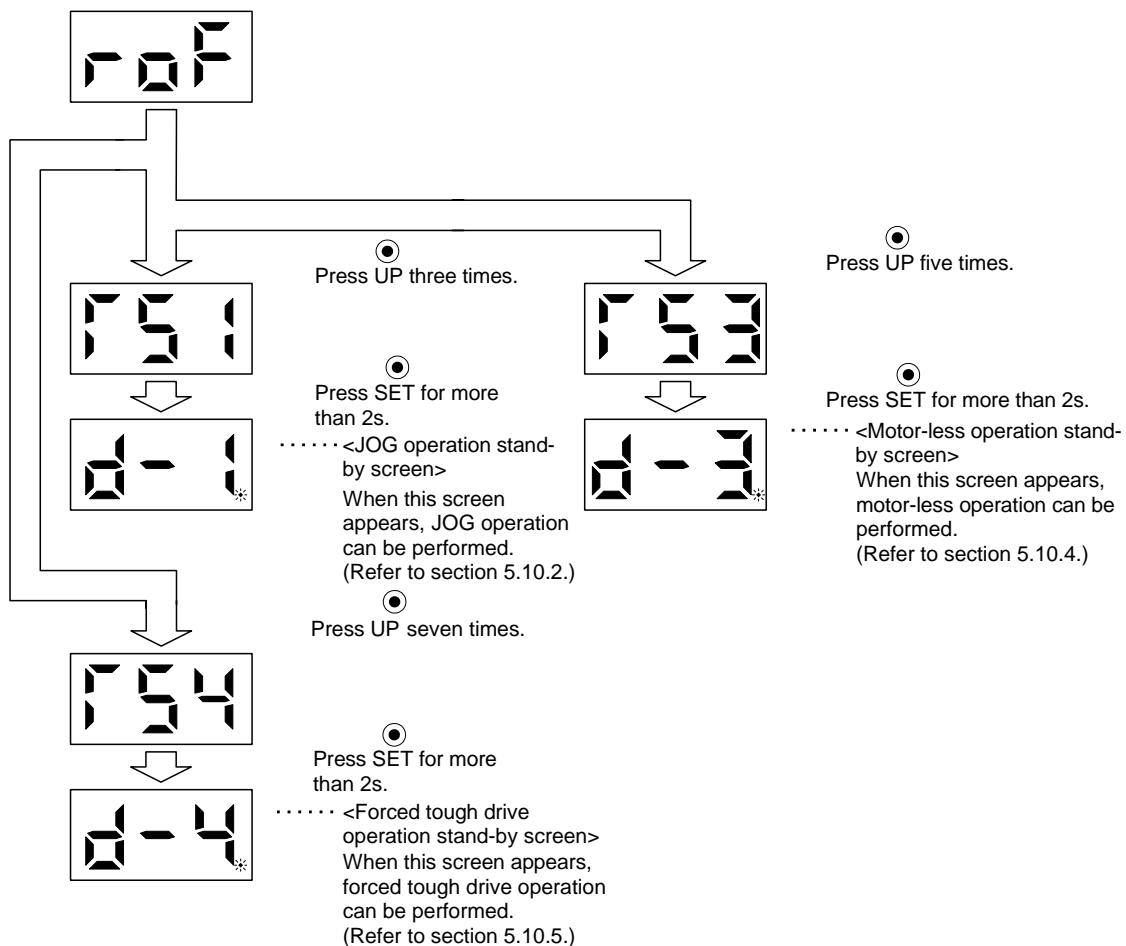

5. DISPLAY AND OPERATION SECTIONS

5.10.2 JOG operation

POINT
<ul style="list-style-type: none"> When performing JOG operation, turn ON the forced stop (EM1), the forward rotation stroke end (LSP) and the reverse rotation stroke end (LSN). The forward rotation stroke end (LSP) and the reverse rotation stroke end (LSN) can be set to automatic ON by setting parameter No. PD01 to "□ C □□".

JOG operation can be performed when there is no command from the external command device.

(1) Operation

The servo motor rotates while holding down the "UP" or the "DOWN" button. The servo motor stops rotating by releasing the button. The operation condition can be changed using MR Configurator. The initial setting values and setting ranges for operation are listed below.

Item	Initial setting	Setting range
Speed [r/min]	200	0 to instantaneous permissible speed
Acceleration/deceleration time constant [ms]	1000	0 to 50000

How to use the buttons is explained below.

Button	Description
"UP"	Press to start CCW rotation. Release to stop.
"DOWN"	Press to start CW rotation. Release to stop.

If the communication cable is disconnected during the JOG operation using MR Configurator, the servo motor decelerates to a stop.

(2) Status display

Call the status display screen by pressing the "MODE" button in the JOG operation stand-by status.

When the JOG operation is performed using the "UP" or the "DOWN" button, the servo status during the JOG operation appears on the display. The status display screen shifts to the next screen every time the "MODE" button is pressed. The status display screen returns to the JOG operation stand-by screen after one screen cycle. For details of the status display, refer to section 5.3. Note that the status display screen cannot be changed by the "UP" or the "DOWN" button in the JOG operation mode.

(3) Termination of JOG operation

To end the JOG operation, turn the power off once or press the "MODE" button to switch to the next screen, and then hold down the "SET" button for 2[s] or longer.

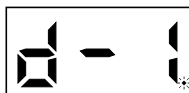

5. DISPLAY AND OPERATION SECTIONS

5.10.3 Positioning operation

POINT
<ul style="list-style-type: none"> ▪ MR Configurator is required to perform positioning operation. ▪ Turn ON the forced stop (EM1) when performing positioning operation. ▪ During positioning operation, the "UP" and the "DOWN" buttons are invalid.

With no command given from the external command device, positioning operation can be executed once.

(1) Operation

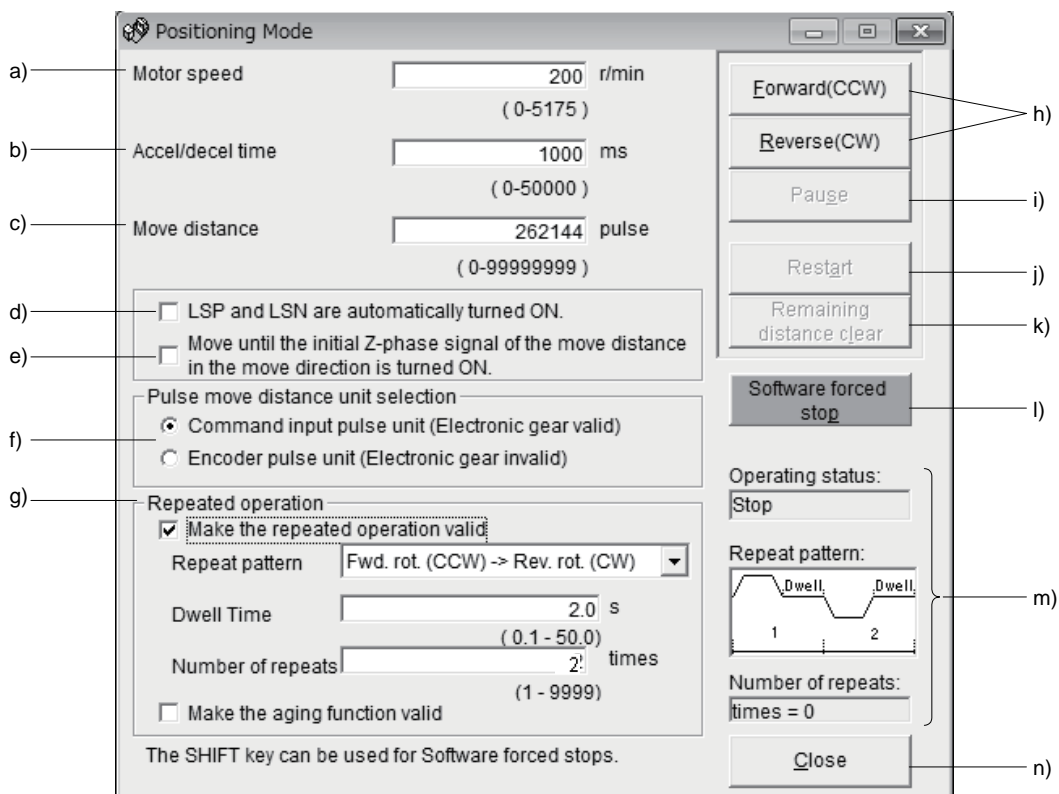

a) Motor speed [r/min]

Enter the servo motor speed into the "Motor speed" input field.

b) Accel/decel time [ms]

Enter the acceleration/deceleration time constant into the "Accel/decel time" input field.

c) Move distance [pulse]

Enter the moving distance into the "Move distance" input field.

d) LSP/LSN automatically turned ON

When setting the external stroke signal to automatic ON, click the check box to make it valid. When it is not checked, turn ON LSP/LSN externally.

e) Move until the initial Z-phase signal of the move distance in the move direction is turned ON.

Movement is made until the initial Z-phase signal of the move distance in the move direction is turned ON.

5. DISPLAY AND OPERATION SECTIONS

f) Pulse move distance unit selection/Command input pulse unit/Encoder pulse unit

Select with the option buttons whether the moving distance set in c) is in the command pulse unit or in the encoder pulse unit.

When the command input pulse unit is selected, the value, which is the set moving distance multiplied by the electronic gear ($\frac{CMX}{CDV}$), will be the command value. When the encoder pulse unit is selected, the moving distance is not multiplied by the electronic gear.

g) Repeated operation

Click the check box of "Make the repeated operation valid" to execute a repeated operation. The following lists the initial conditions and setting ranges for the repeated operation.

Item	Initial setting	Setting range
Repeated pattern	Forward rotation (CCW) to reverse rotation (CW)	Forward rotation (CCW) to reverse rotation (CW) Forward rotation (CCW) to Forward rotation (CCW) Reverse rotation (CW) to forward rotation (CCW) Reverse rotation (CW) to Reverse rotation (CW)
Dwell Times	2.0	0.1 to 50.0
Number of repeats (times)	1	1 to 9999

Click the check box of "Make the aging function valid" to execute the repeated operation with the repeated pattern and the dwell time set above.

h) Forward/Reverse

Click the "Forward" button to rotate the servo motor in the forward rotation direction.

Click the "Reverse" button to rotate the servo motor in the reverse rotation direction.

i) Pause

Click the "Pause" button during servo motor rotation to temporarily stop the servo motor.

This button is valid during servo motor rotation.

j) Restart

Click the "Restart" button during a temporary stop to restart the servo motor rotation.

This button is valid during a temporary stop of the servo motor.

k) Remaining move distance clear

Click the "Remaining distance clear" button during a temporary stop to erase the remaining distance.

This button is valid during a temporary stop of the servo motor.

l) Forced stop

Click the "S/W forced stop" button during servo motor rotation to make a hard stop.

This button is valid during servo motor rotation.

5. DISPLAY AND OPERATION SECTIONS

m) Repeated operation status

Operation status, repeated pattern, the number of repeats in the repeated operation is displayed.

n) Close

Click the "Close" button to cancel the positioning operation mode and close the window.

(2) Status display

The status display can be monitored during positioning operation.

5.10.4 Motor-less operation

Without a servo motor being connected, the output signals are provided and the status is displayed as if the servo motor is running in response to input device. This operation can be used to check the sequence of a host programmable logic controller or the like.

(1) Operation

Turn off the servo-on (SON), and then select motor-less operation. After that, perform external operation as in ordinary operation.

(2) Status display

The servo status can be checked in the motor-less operation.

Change the display to the status display screen by pressing the "MODE" button. (Refer to section 5.2.)

The status display screen can be changed by pressing the "UP" or the "Down" button. (Refer to section 5.3.)

(3) Termination of motor-less operation

To terminate the motor-less operation, turn the power off.

5. DISPLAY AND OPERATION SECTIONS

5.10.5 Forced tough drive operation

POINT	
▪ Execute forced tough drive operation after ten minutes of normal operation.	

The tough drive can be checked in advance by forcing the overload tough drive, even if the servo motor is in the normal status.

(1) Operation

Press the "SET" button for 2[s] or longer in normal operation to execute the forced tough drive operation.

(2) Status display

Call the status display screen by pressing the "MODE" button in the forced tough drive operation stand-by status. The status display screen returns to the forced tough drive operation stand-by screen after one screen cycle. For details of the status display, refer to section 5.3. Note that the status display screen cannot be changed by the "UP" or the "DOWN" button in the forced tough drive operation mode.

(3) Termination of forced tough drive operation

To end the forced tough drive operation, turn the power off once, or press the "MODE" button to switch to the next screen and then hold down the "SET" button for 2[s] or longer.

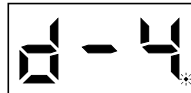

5.11 One-touch tuning

POINT	
▪ For full information of the one-touch tuning, refer to section 6.1.	

Press the "AUTO" button for 3[s] or longer in the position control mode, the internal speed control mode or the positioning mode, and then press it again to execute the one-touch tuning.

6. GENERAL GAIN ADJUSTMENT

6. GENERAL GAIN ADJUSTMENT

POINT
<ul style="list-style-type: none">▪ When using in the internal torque control mode, gain adjustment is not necessary.▪ When making gain adjustment, check that the machine is not operated at the maximum torque of the servo motor. The operation at the maximum torque or more may cause unexpected operations such as machine vibration, etc. Consider individual machine differences, and do not adjust gain too strictly. It is recommended to keep the servo motor torque to 90% or less of the maximum torque of the servo motor during the operation.

6.1 One-touch tuning

Just by pressing the "AUTO" button on the front panel of the servo amplifier, the gain/filter is easily adjusted. The following parameters are automatically adjusted by the one-touch tuning.

Parameter No.	Symbol	Name
PA08	ATU	Auto tuning mode
PA09	RSP	Auto tuning response
PB03	PST	Position command acceleration/ deceleration time constant (Position smoothing)
PB07	PG1	Model loop gain
PB12	OVA	Overshoot amount compensation
PB13	NH1	Machine resonance suppression filter 1
PB14	NHQ1	Notch shape selection 1
PB15	NH2	Machine resonance suppression filter 2
PB16	NHQ2	Notch shape selection 2

6. GENERAL GAIN ADJUSTMENT

6.1.1 One-touch tuning procedure

Use the following procedure to perform the one-touch tuning.

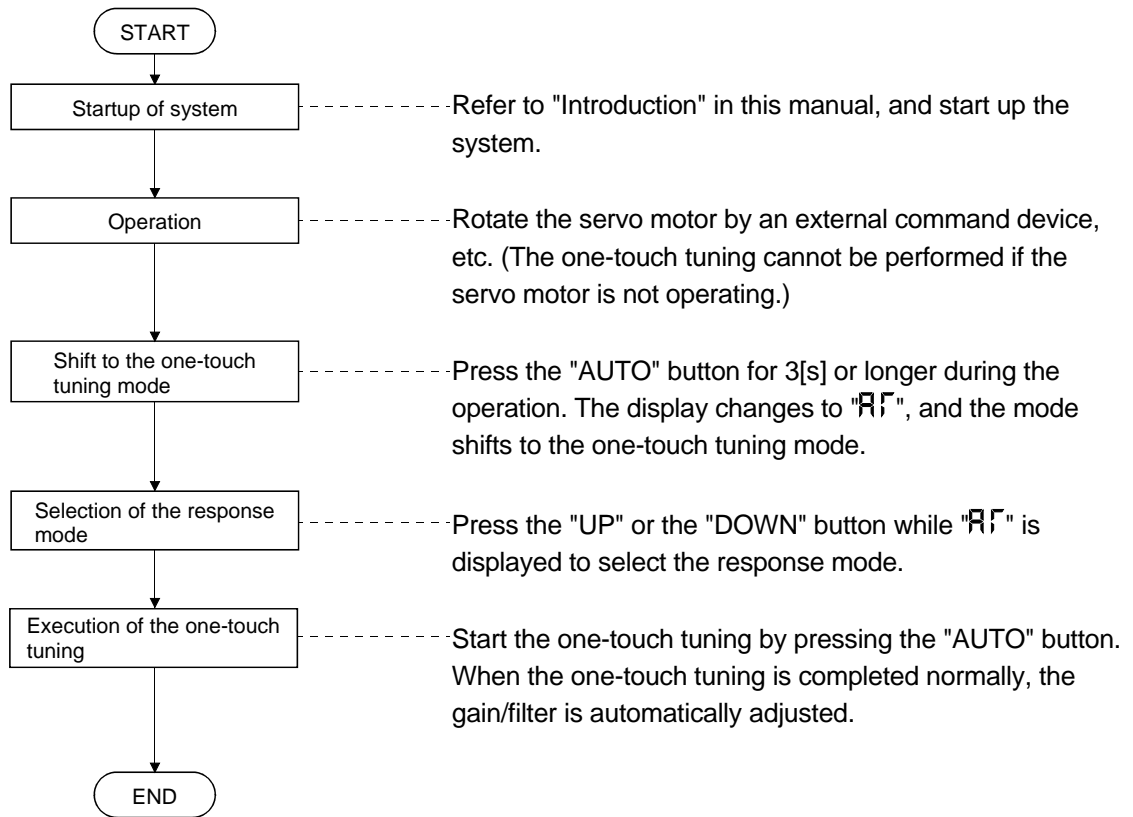

6. GENERAL GAIN ADJUSTMENT

6.1.2 Display transition and operation procedure of the one-touch tuning

(1) Selection of the response mode

Select the response mode of the one-touch tuning (three types) by the "UP" and the "DOWN" buttons.

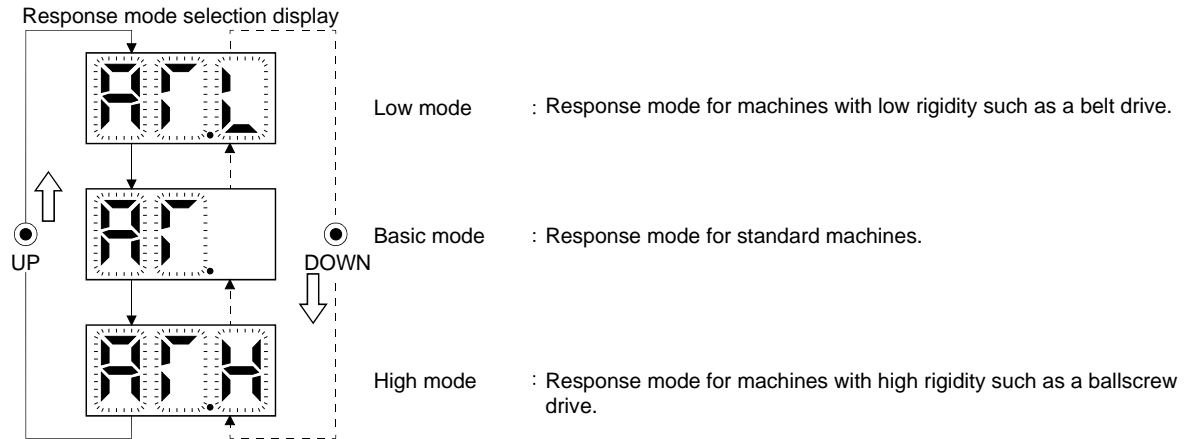

Response mode			Response level	Machine characteristic
Low mode	Basic mode	High mode		Guideline of corresponding machine
↑ ↓	↑ ↓	↑ ↓	↑ ↓	
			Low response High response	

The one-touch tuning mode will be canceled in 10[s] after shifting to the one-touch tuning mode. Then, the mode returns to the status display at power-on.

6. GENERAL GAIN ADJUSTMENT

(2) Performing the one-touch tuning

Select the response mode in (1), and press the "AUTO" button to start the one-touch tuning.

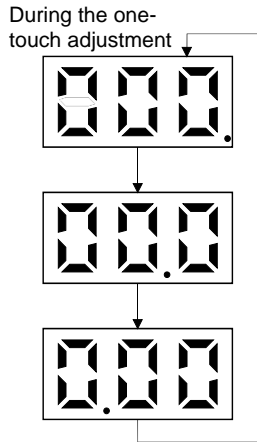

The progress of the one-touch tuning is displayed from 0 to 100%. During the one-touch tuning, the decimal point is lit, moving from right to left. Pressing the "MODE" button during the one-touch tuning calls the status display.

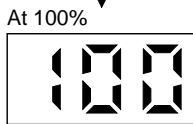

When the progress of the one-touch tuning reaches 100%, the parameters adjusted automatically in the one-touch tuning are written into the servo amplifier.

The completion display is called 1s later.

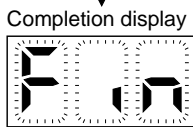

At completion, "Fin" flickers regardless of the item displayed.

Pressing any button calls the settling time (status display).

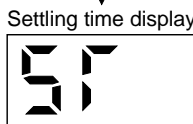

The settling time of the status display is displayed, and the value is displayed 2s later. The "UP" and "DOWN" buttons enable to call other status displays, and the "MODE" button enables to call the diagnostic mode.

↓ 2s later



Settling time (100ms)

POINT

- The settling time can also be checked in the status display mode. (Refer to section 5.3.)

6. GENERAL GAIN ADJUSTMENT

(3) Cancelling the one-touch tuning

Cancel symbol display



In the one-touch tuning mode regardless of the item displayed, pressing "AUTO" button cancels the one-touch tuning mode.

At 2s intervals

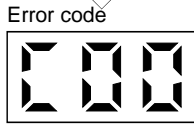

The cancel symbol display and error code "C00" (cancel during the adjustment) are displayed alternately every 2s.

Pressing any button calls the status display at power-on.

Status display at power-on (in the position control mode).



(4) At error occurrence

Cancel symbol display



If some error occurs during the one-touch tuning, the one-touch tuning is canceled, and the cancel symbol display and error code "C01" to "C04" are displayed alternately every 2s.

At 2s intervals

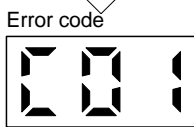

Refer to the following table to remove the cause of the error.

Display	Name	Description	Action
C00	Cancel during the adjustment	The "AUTO" button was pressed again during the adjustment to cancel the adjustment. (Refer to paragraph (3) of this section.)	
C01	Excessive overshoot	The overshoot is larger than the value set in the in-position range (parameter No. PA10).	Increase the in-position range (parameter No. PA10).
C02	Servo-off during the adjustment	The one-touch tuning was attempted while the servo-on (SON) was turned OFF.	Perform the one-touch tuning after turning on the servo-on (SON).
C03	Control mode fault	The one-touch tuning was attempted while the internal torque control mode was selected from the control modes.	Select the position control mode or internal speed control mode for the control mode, and perform the one-touch tuning.
C04	Time-out	1. 1 cycle time during the operation is over 30s.	Set the 1 cycle time during the operation to 30s or less.
		2. The servo motor speed is lower than 100r/min.	Set the servo motor speed to 100r/min or higher.
		3. The operation interval of the continuous operation is short.	Set the stop time during the operation longer.

}



Pressing any button calls the status display at power-on.

Status display at power-on (in the position control mode).

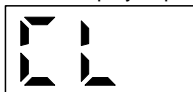

6. GENERAL GAIN ADJUSTMENT

(5) At alarm occurrence

During the one-touch tuning



If some alarm occurs during the one-touch tuning, the one-touch tuning is canceled, and the alarm display is called.

↓
Alarm display



(6) At warning occurrence

During the one-touch tuning



(a) If some warning occurs during the one-touch tuning, the alarm display is called, and the warning is displayed. However, one-touch tuning continues to be performed.
(b) When the warning is reset, the alarm display is shifted to the one-touch tuning.

Warning
reset ↑ ↓ Waning
occurrence

Alarm display (warning)



↓
Completion display

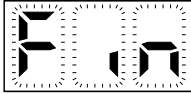

One-touch tuning complete

6. GENERAL GAIN ADJUSTMENT

(7) Clearing the one-touch tuning

POINT

- The one-touch tuning result can be reset to the initial value by the clear (CLr) mode and to the value before the adjustment by the back (bAC) mode.

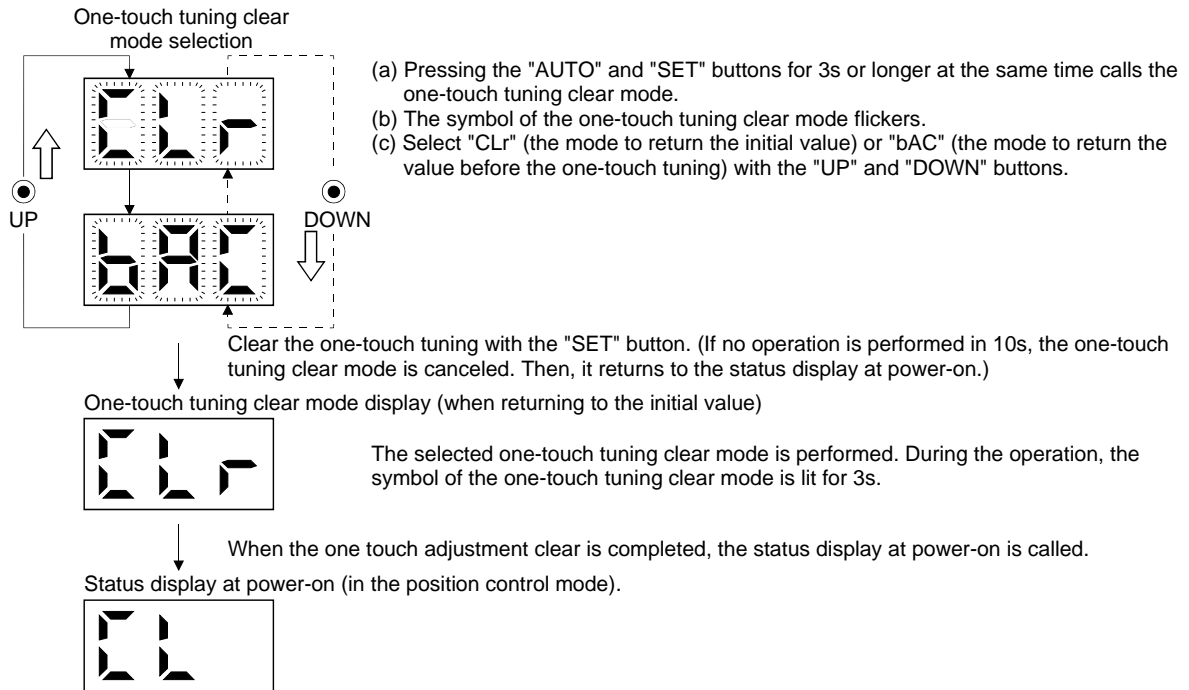

6.1.3 Precautions for one-touch tuning

- (1) In the internal torque control mode, the "AUTO" button is invalid.
- (2) When an alarm or a warning occurs, the one-touch tuning is not available.
- (3) While performing the following test operation modes, the one-touch tuning is not available.
 - (a) Output signal (DO) forced output
 - (b) Motor-less operation
 - (c) Forced tough drive operation

6. GENERAL GAIN ADJUSTMENT

6.2 Gain adjustment methods

The gain adjustment in this section can be made on a single servo amplifier. For the gain adjustment, refer to (3) in this section.

(1) One-touch tuning

Gain adjustment method	Parameter No. PA08 setting	Estimation of load to motor inertia moment ratio	Automatically set parameters	Manually set parameters
Operation of the one-touch tuning button (AUTO) on the front panel of the servo amplifier (Refer to section 6.1.)	<ul style="list-style-type: none"> ▪ Automatically changes to "000", when the value before the one-touch tuning is "000" or "001". ▪ "003", when the value before the one-touch tuning is "003". (No change) 	Always estimated	AUT (parameter No. PA08) RSP (parameter No. PA09) PST (parameter No. PB03) PG1 (parameter No. PB07) OVA (parameter No. PB12) NH1 (parameter No. PB13) NHQ1 (parameter No. PB14) NH2 (parameter No. PB15) NHQ2 (parameter No. PB16)	/

(2) Gain adjustment made by the auto tuning mode (parameter No. PA08)

Gain adjustment method	Parameter No. PA08 setting	Estimation of load to motor inertia moment ratio	Automatically set parameters	Manually set parameters
Auto tuning mode 1 (initial value)	001	Always estimated	GD2 (parameter No. PB06) PG1 (parameter No. PB07) PG2 (parameter No. PB08) VG2 (parameter No. PB09) VIC (parameter No. PB10)	RSP (parameter No. PA09)
2-gain adjustment mode	000	Always estimated	GD2 (parameter No. PB06) PG2 (parameter No. PB08) VG2 (parameter No. PB09) VIC (parameter No. PB10)	PG1 (parameter No. PB07) RSP (parameter No. PA09)
Manual mode	003	Fixed to parameter No. PB06 value	/	GD2 (parameter No. PB06) PG1 (parameter No. PB07) PG2 (parameter No. PB08) VG2 (parameter No. PB09) VIC (parameter No. PB10)

6. GENERAL GAIN ADJUSTMENT

(3) Adjustment sequence and mode usage

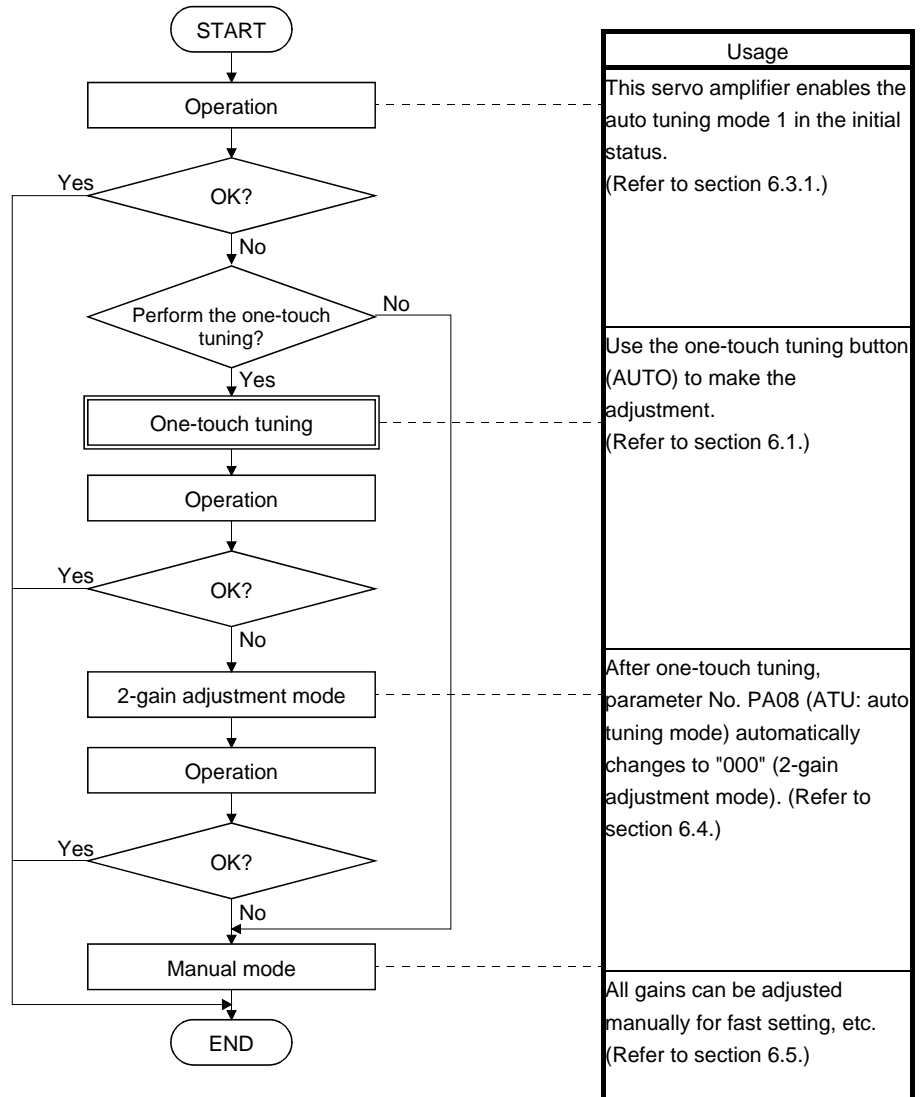

6. GENERAL GAIN ADJUSTMENT

6.3 Auto tuning mode 1

6.3.1 Overview

The servo amplifier has a real-time auto tuning function which estimates the machine characteristic (load to motor inertia moment ratio) in real time and automatically sets the optimum gains according to that value. This function permits ease of gain adjustment of the servo amplifier.

The servo amplifier is factory-set to the auto tuning mode 1.

In this mode, the load to motor inertia moment ratio of a machine is always estimated to set the optimum gains automatically.

The following parameters are automatically adjusted in the auto tuning mode 1.

Parameter No.	Abbreviation	Name
PB06	GD2	Load to motor inertia moment ratio
PB07	PG1	Model loop gain
PB08	PG2	Position loop gain
PB09	VG2	Speed loop gain
PB10	VIC	Speed integral compensation

POINT

- The auto tuning mode 1 may not be performed properly if the following conditions are not satisfied.
 - Time to reach 2000r/min is the acceleration/deceleration time constant of 5[s] or less.
 - Speed is 150r/min or higher.
 - Load to motor inertia moment ratio is 100 times or less.
 - The acceleration/deceleration torque is 10% or more of the rated torque.
- Under operating conditions which imposes sudden disturbance torque during acceleration/deceleration or on a machine which is extremely loose, auto tuning may not function properly, either. In such cases, use the one-touch tuning, the 2-gain adjustment mode, or the manual mode to make gain adjustment.

6. GENERAL GAIN ADJUSTMENT

6.3.2 Auto tuning mode 1 basis

The function block diagram of real-time auto tuning is shown below.

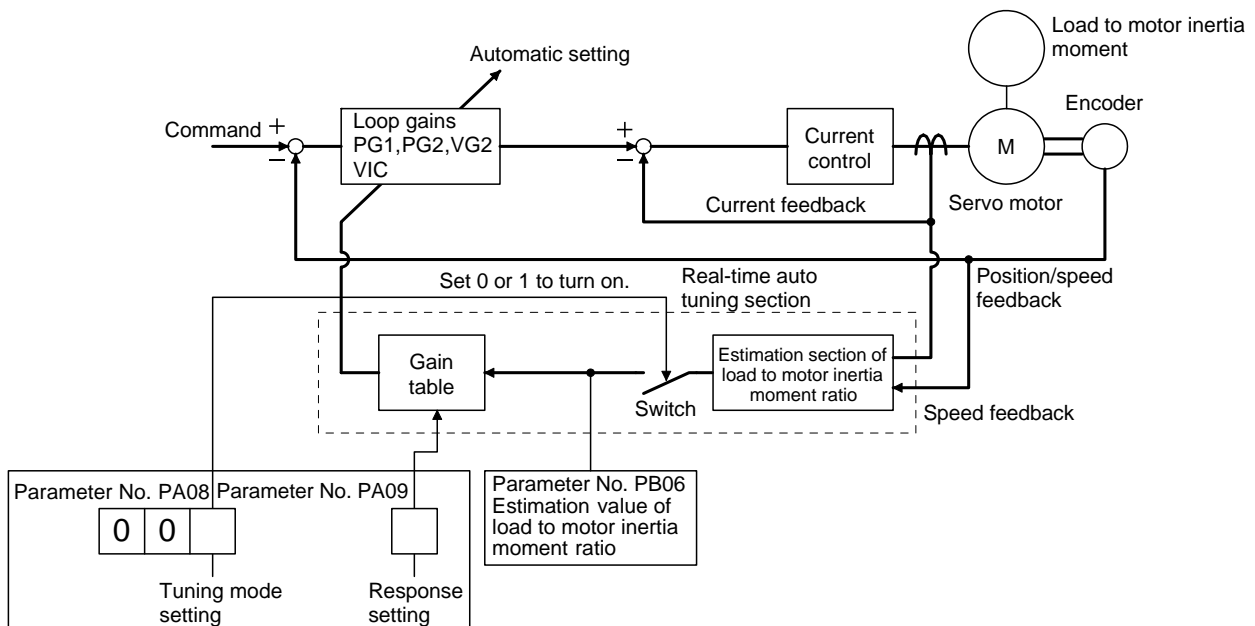

When a servo motor is accelerated/decelerated, the load to motor inertia moment ratio estimation section always estimates the load to motor inertia moment ratio from the current and the speed of the servo motor. The results of estimation are written to parameter No. PB06 (load to motor inertia moment ratio). These results can be confirmed on the status display screen of the MR Configurator section.

If the value of the load to motor inertia moment ratio is already known or if the estimation cannot be made properly, select "manual mode" by setting parameter No. PA08 to "003" (the switch in the above diagram turns off) to stop the estimation of the load to motor inertia moment ratio. Then, set the load to motor inertia moment ratio manually to parameter No. PB06.

From the preset load to motor inertia moment ratio (parameter No. PB06) value and response level (parameter No. PA09), the optimum loop gains are automatically set on the basis of the internal gain table.

The auto tuning results are saved in the EEP-ROM of the servo amplifier every 60 minutes since power-on. At power-on, auto tuning is performed with the value of each loop gain saved in the EEP-ROM being used as an initial value.

POINT
<ul style="list-style-type: none"> ▪ If sudden disturbance torque is imposed during the operation, the estimation of the load to motor inertia moment ratio may malfunction temporarily. In such a case, select the "manual mode" (parameter No. PA08: 003) and set the correct load to motor inertia moment ratio in parameter No. PB06. ▪ When any of the auto tuning mode 1 and 2-gain adjustment mode settings is changed to the manual mode setting, the current loop gains and load to motor inertia moment ratio estimation value are saved in the EEP-ROM.

6. GENERAL GAIN ADJUSTMENT

6.3.3 Adjustment procedure by auto tuning

Since auto tuning is made valid before shipment from the factory, simply running the servo motor automatically sets the optimum gains that match the machine. Merely changing the response level setting value as required completes the adjustment. The adjustment procedure is as follows.

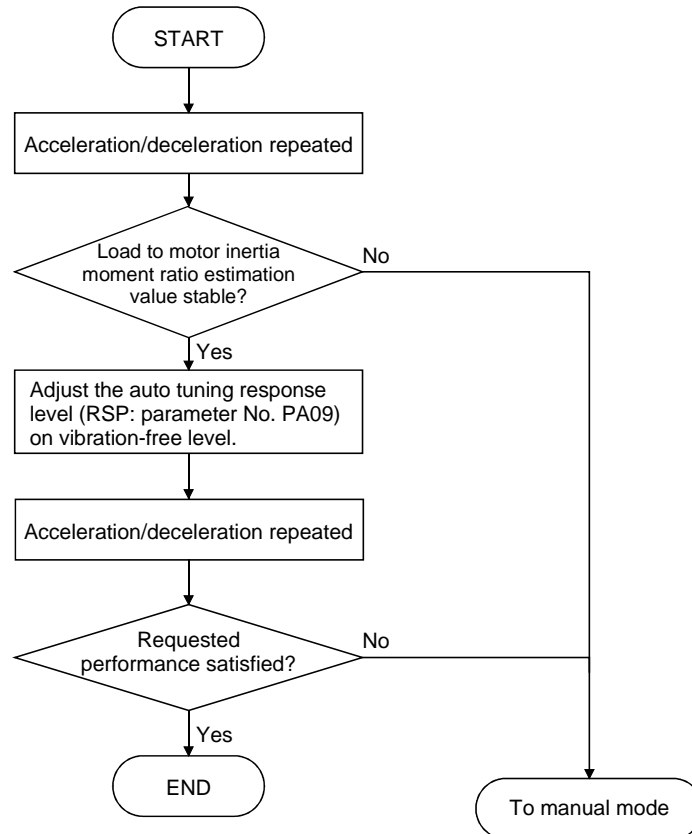

6. GENERAL GAIN ADJUSTMENT

6.3.4 Response level setting in auto tuning mode 1

Set the response (The first digit of parameter No. PA09) of the whole servo system. As the response level setting is increased, the track ability and settling time for a command decreases, but a too high response level will generate vibration. Hence, make setting until desired response is obtained within the vibration-free range.

If the response level setting cannot be increased up to the desired response because of machine resonance beyond 100Hz, adaptive tuning mode (parameter No. PB01) or machine resonance suppression filter (parameter No. PB13 to PB16, PB38, PB39) may be used to suppress machine resonance. Suppressing machine resonance may allow the response level setting to increase.

Refer to section 7.2 for adaptive tuning mode and machine resonance suppression filter.

Setting of parameter No. PA09

Response level setting	Machine characteristic	
	Machine rigidity	Guideline of corresponding machine
1	<div style="text-align: center;"> Low ↑ ↓ Middle ↑ ↓ High </div>	<p>The diagram consists of four overlapping circles. The top-left circle is labeled 'Arm robot'. The bottom-left circle is labeled 'Precision working machine'. The top-right circle is labeled 'General machine tool conveyor'. The bottom-right circle is labeled 'Inserter Mounter Bonder'. The circles overlap in various combinations, creating a central area where all four overlap.</p>
2		
3		
4		
5		
6		
7		
8		
9		
10		
11		
12		
13		
14		
15		
16		

6. GENERAL GAIN ADJUSTMENT

6.4 2-gain adjustment mode

POINT	<ul style="list-style-type: none"> Use this mode to improve the response level after the one-touch tuning. Use parameters No. PA09 or PB07 for fine adjustment.
-------	--

Use the 2-gain adjustment mode for fine adjustment of the response level setting and the model loop gain.

(1) Parameters

(a) Automatically adjusted parameters

The following parameters are automatically adjusted by the auto tuning 1.

Parameter No.	Abbreviation	Name
PB06	GD2	Load to motor inertia moment ratio
PB08	PG2	Position loop gain
PB09	VG2	Speed loop gain
PB10	VIC	Speed integral compensation

(b) Manually adjusted parameters

The following parameters are adjustable manually.

Parameter No.	Abbreviation	Name
PA09	RSP	Auto tuning response
PB07	PG1	Model loop gain

(2) Adjustment procedure

Step	Operation	Description
1	Set to the 2-gain adjustment mode.	Set parameter No. PA08 (auto tuning mode) to "□□0".
2	During the operation, increase the response level setting (parameter No. PA09), and reset the setting if vibration occurs.	Adjustment of the servo stability
3	During the operation, increase the model loop gain (parameter No. PB07), and reset the setting if overshoot occurs.	Adjustment of the position track ability

(3) Adjustment description

The droop pulse value is determined by the following expression.

$$\text{Droop pulse value (pulse)} = \frac{\frac{\text{Rotation speed (r/min)}}{60} \times \text{Servo motor resolution (pulse/rev)}}{\text{Model loop gain setting}}$$

6. GENERAL GAIN ADJUSTMENT

6.5 Manual mode

If the adjustment made by the auto tuning mode 1 and 2-gain adjustment mode is not satisfactory, adjust the load to motor inertia moment and all gains in the manual mode.

POINT
<ul style="list-style-type: none"> ▪ Use this mode if the estimation of the load to motor inertia moment ratio is not the normal value. ▪ Use this mode to perform the vibration suppression control tuning.

(1) For internal speed control

(a) Parameters

The following parameters are used for gain adjustment.

Parameter No.	Abbreviation	Name
PB06	GD2	Load to motor inertia moment ratio
PB07	PG1	Model loop gain
PB09	VG2	Speed loop gain
PB10	VIC	Speed integral compensation

(b) Adjustment procedure

Step	Operation	Description
1	Brief-adjust with auto tuning. Refer to section 6.3.3.	
2	Change the setting of the tuning mode to the manual mode (Parameter No. PA08: 003)	
3	Set an estimated value to load to motor inertia moment ratio. (If the estimate value with auto tuning is correct, setting change is not required.)	
4	Set a slightly smaller value to the model loop gain. Set a slightly larger value to the speed integral compensation.	
5	Increase the speed loop gain within the vibration- and unusual noise-free range, and return slightly if vibration takes place.	Increase the speed loop gain.
6	Decrease the speed integral compensation within the vibration-free range, and return slightly if vibration takes place.	Decrease the time constant of the speed integral compensation.
7	Increase the model loop gain, and return slightly if overshooting takes place.	Increase the model loop gain.
8	If the gains cannot be increased due to mechanical system resonance or the like, and the desired response cannot be achieved, response may be increased by executing steps 3 to 7 after suppressing the resonance by the adaptive tuning mode or the machine resonance suppression filter.	Suppression of machine resonance. (Refer to section 7.2.)
9	While checking the rotational status, fine-adjust the each gain.	Fine adjustment

6. GENERAL GAIN ADJUSTMENT

(c) Adjustment description

1) Speed loop gain (VG2: parameter No. PB09)

This parameter determines the response level of the speed control loop. Increasing this value enhances response but a too high value will make the mechanical system liable to vibrate. The actual response frequency of the speed loop is as indicated in the following expression.

$$\text{Speed loop response frequency(Hz)} = \frac{\text{Speed loop gain setting}}{(1 + \text{load to motor inertia moment ratio}) \times 2\pi}$$

2) Speed integral compensation (VIC: parameter No. PB10)

To eliminate stationary deviation against a command, the speed control loop is under proportional integral control. For the speed integral compensation, set the time constant of this integral control. Increasing the setting lowers the response level. However, if the load to motor inertia moment ratio is large or the mechanical system has any vibratory element, the mechanical system is liable to vibrate unless the setting is increased to some degree. The guideline is as indicated in the following expression.

$$\text{Speed integral compensation setting(ms)} \geq \frac{2000 \text{ to } 3000}{\text{Speed loop gain setting} / (1 + \text{load to motor inertia moment ratio setting})}$$

3) Model loop gain (PG1: parameter No. PB07)

This parameter determines the response level for the position command. Increasing the model loop gain improves the track ability to a position command. If the gain is too high; however, overshooting is likely to occur when settling.

$$\text{Model loop gain guideline} \leq \frac{\text{Speed loop gain setting}}{(1 + \text{load to motor inertia moment ratio})} \times \left(\frac{1}{4} \text{ to } \frac{1}{8} \right)$$

(2) For position control

(a) Parameters

The following parameters are used for gain adjustment.

Parameter No.	Abbreviation	Name
PB06	GD2	Load to motor inertia moment ratio
PB07	PG1	Model loop gain
PB08	PG2	Position loop gain
PB09	VG2	Speed loop gain
PB10	VIC	Speed integral compensation

6. GENERAL GAIN ADJUSTMENT

(b) Adjustment procedure

Step	Operation	Description
1	Brief-adjust with auto tuning. Refer to section 6.3.3.	
2	Change the setting of the tuning mode to the manual mode (Parameter No. PA08: 003)	
3	Set an estimated value to the load to motor inertia moment ratio. (If the estimate value with auto tuning is correct, setting change is not required.)	
4	Set a slightly smaller value to the model loop gain and the position loop gain. Set a slightly larger value to the speed integral compensation.	
5	Increase the speed loop gain within the vibration- and unusual noise-free range, and return slightly if vibration takes place.	Increase the speed loop gain.
6	Decrease the speed integral compensation within the vibration-free range, and return slightly if vibration takes place.	Decrease the time constant of the speed integral compensation.
7	Increase the position loop gain, and return slightly if vibration takes place.	Increase the position loop gain.
8	Increase the model loop gain, and return slightly if overshooting takes place.	Increase the model loop gain.
9	If the gains cannot be increased due to mechanical system resonance or the like and the desired response cannot be achieved, response may be increased by suppressing resonance with adaptive tuning mode or machine resonance suppression filter and then executing steps 3 to 8.	Suppression of machine resonance. (Refer to section 7.2.)
10	While checking the settling characteristic and rotational status, fine-adjust each gain.	Fine adjustment

(c) Adjustment description

1) Speed loop gain (VG2: parameter No. PB09)

The same as for the internal speed control.

2) Speed integral compensation (VIC: parameter No. PB10)

The same as for the internal speed control.

3) Position loop gain (PG2: parameter No. PB08)

This parameter determines the response level to the disturbance of the position control loop.

Increasing position loop gain decreases the change at external disturbance. If the gain is too high; however, overshooting is likely to occur when settling.

$$\text{Position loop gain guideline} \leq \frac{\text{Speed loop gain 2 setting}}{(1 + \text{load to motor inertia moment ratio})} \times \left(\frac{1}{4} \text{ to } \frac{1}{8} \right)$$

4) Model loop gain (PG1: parameter No. PB07)

This parameter determines the response level of the model loop. Increasing position loop gain 1 improves track ability to a position command but a too high value will make overshooting liable to occur at the time of settling.

$$\text{Model loop gain guideline} \leq \frac{\text{Speed loop gain 2 setting}}{(1 + \text{load to motor inertia moment ratio})} \times \left(\frac{1}{4} \text{ to } \frac{1}{8} \right)$$

7. SPECIAL ADJUSTMENT FUNCTIONS

7. SPECIAL ADJUSTMENT FUNCTIONS

7.1 Tough drive function

POINT
<ul style="list-style-type: none"> Enable or disable the tough drive function by parameter No. PA04 (tough drive function selection). (Refer to section 4.1.5.)

The tough drive function continues the operation not to stop a machine in such situations when normally an alarm is activated.

7.1.1 Overload tough drive function

 CAUTION	<ul style="list-style-type: none"> When the overload tough drive activates, the operation pattern is changed. Check in advance if equipment problems due to the change of operation pattern do not occur. The operation pattern at the overload tough drive can be checked with the forced tough drive operation in the test operation mode. (Refer to section 5.10.5.)
---	--

The overload tough drive function automatically reduces the load ratio to about 70% to avoid an alarm when the effective load ratio increases to near the overload alarm level. When the overload tough drive activates, the servo amplifier delays the time for the in-position (INP) and the zero speed (ZSP) to turn on. In the position control mode, the controller holds the next command until the in-position (INP) turns on. In the positioning mode, the controller holds the output of position command until the in-position (INP) turns on. The during tough drive (MTTR) can be output from the servo amplifier by setting parameter No. PD20 (function selection D-1) to " □ 1 □ □ ".

POINT
<ul style="list-style-type: none"> The overload tough drive function is available only in the position control mode or in the positioning mode. The increase in the load ratio that is caused by temporary load fluctuations can be avoided by reducing the machine tact (operating time) so that the operation can be continued. An optimum in-position (INP) delay time is calculated automatically on the servo amplifier side. The maximum delay time of the in-position (INP) can be limited by parameter No. PC26 (detailed setting of overload tough drive) so as not to cause INP timeout error on the controller side.

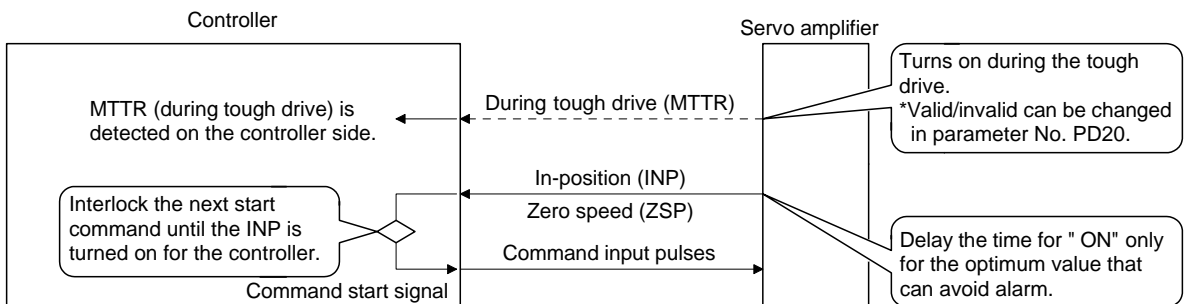

7. SPECIAL ADJUSTMENT FUNCTIONS

However, the overload tough drive function is not effective in the following cases.

- (1) When the effective load ratio temporarily exceeds 200%.
- (2) When the load increases at a stop such as a detent torque of a vertical lift.

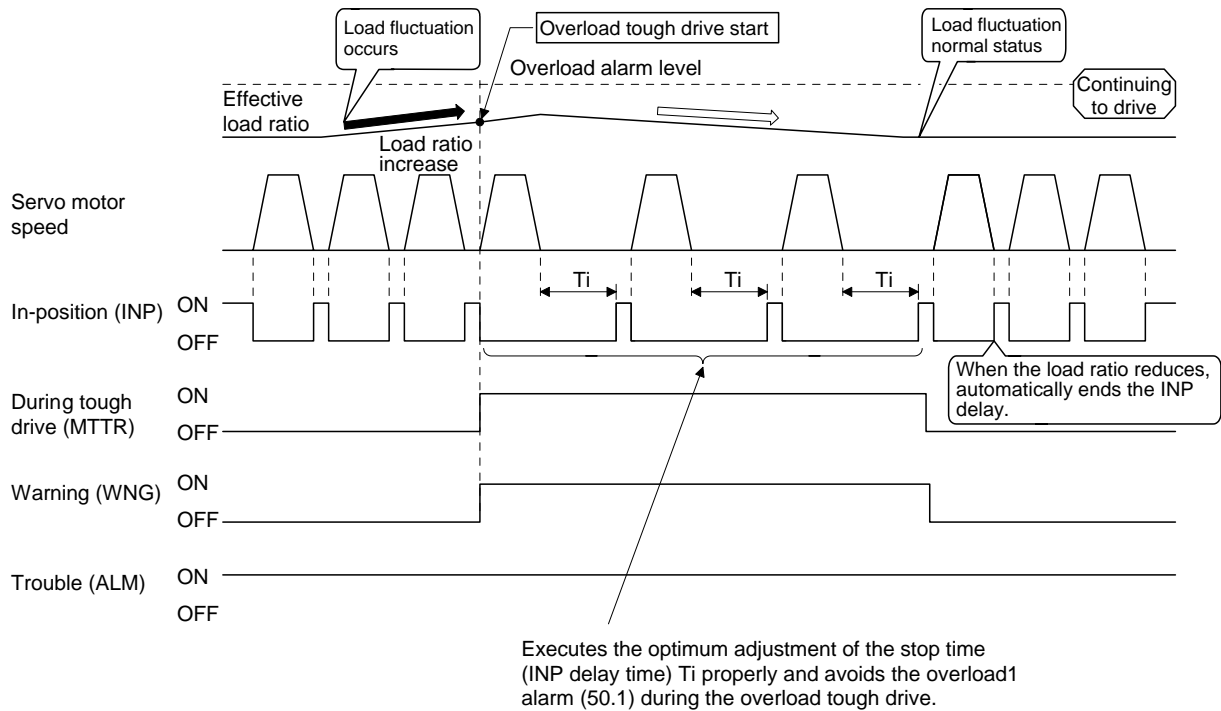

When the overload tough drive activates, the number of tough drive in the display mode (alarm mode) is increased by one. (Refer to section 5.5.)

7.1.2 Vibration tough drive function

The vibration tough drive function resets the filter instantaneously and prevents vibration when a machine resonance is generated due to aging distortion or individual differences.

In order to reset the machine resonance suppression filter by the vibration tough drive function, parameters No. PB13 (machine resonance suppression filter 1) and No. PB15 (machine resonance suppression filter 2) are required to be set in advance.

Perform either of the following to set parameters No. PB13 and No. PB15.

- (1) Perform the one-touch tuning (refer to section 6.1).
- (2) Set the parameters manually (refer to section 4.2.2).

7. SPECIAL ADJUSTMENT FUNCTIONS

The vibration tough drive function activates when a detected machine resonance frequency is within the range of $\pm 30\%$ in relation to the set value of parameters No. PB13 (machine resonance suppression filter 1) and No. PB15 (machine resonance suppression filter 2).

The detection level of the vibration tough drive function can be set by parameter No. PC27 (detailed setting of vibration tough drive).

POINT
<ul style="list-style-type: none"> Resetting of the parameters No. PB13 or No. PB15 by the vibration tough drive function is performed constantly. However, the number of write times to the EEPROM is limited to once per hour. The machine resonance suppression filter 3 (parameter No. PB38) is not reset by the vibration tough drive function.

The following shows the function block diagram of the vibration tough drive function.

The detected machine resonance frequency is compared with the parameters No. PB13 (machine resonance suppression filter 1) and No. PB15 (machine resonance suppression filter 2), and the parameter No. which has a set value closer to the detected machine resonance frequency is reset to the value of the detected frequency.

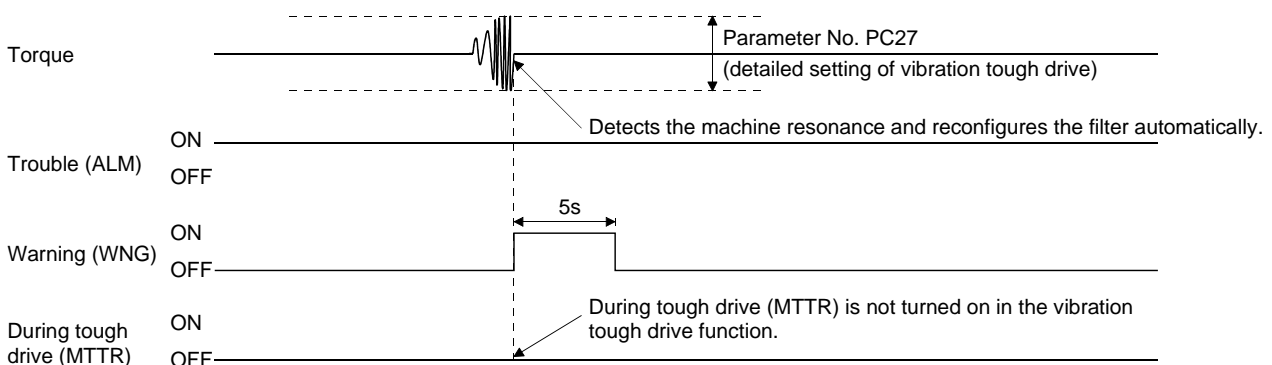
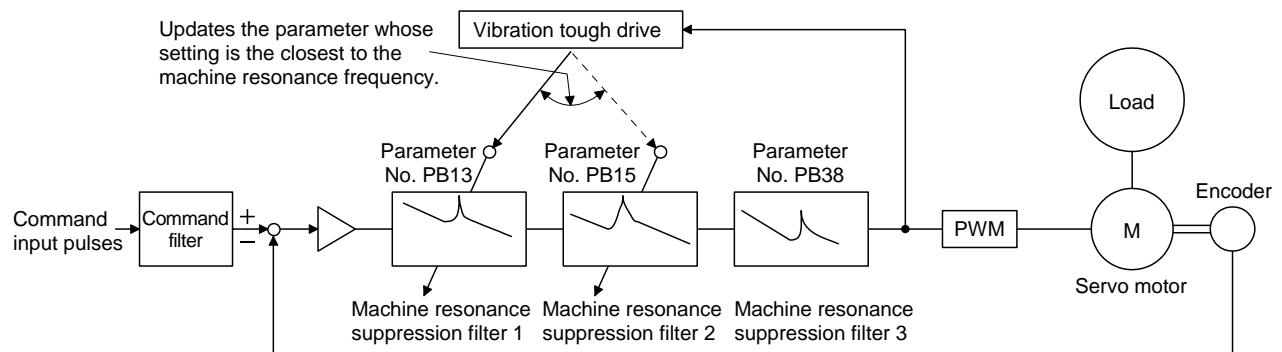

When the vibration tough drive function activates, the number of tough drive in the display mode (alarm mode) is increased by one. (Refer to section 5.5.)

7. SPECIAL ADJUSTMENT FUNCTIONS

7.1.3 Instantaneous power failure tough drive function



- During the instantaneous power failure tough drive, the torque may be limited due to the load conditions or the set value of parameter No. PC28 (detailed setting of instantaneous power failure tough drive).
- The immunity to instantaneous power failures is increased by the instantaneous power failure tough drive function. However, it is not compliant with the SEMI-F47 specification.

The instantaneous power failure tough drive function avoids the instantaneous power failure alarm even when an instantaneous power failure occurs during operation. When the instantaneous power failure tough drive activates, the immunity to instantaneous power failures is increased by using the electrical energy charged in the main circuit capacitor during instantaneous power failures. The instantaneous power failure alarm judgment time for the main circuit power can be changed by parameter No. PC28 (detailed setting of instantaneous power failure tough drive).

POINT

- The electromagnetic brake interlock (MBR) does not turn off during the instantaneous power failure tough drive.
- When the load of instantaneous power failure is heavy, the undervoltage alarm (10.2) caused by the bus voltage drop may occur regardless of the setting value of parameter No. PC28 (detailed setting of instantaneous power failure tough drive).

(1) When the instantaneous main circuit power failure time is shorter than the set value of parameter No. PC28 (detailed setting of instantaneous power failure tough drive)

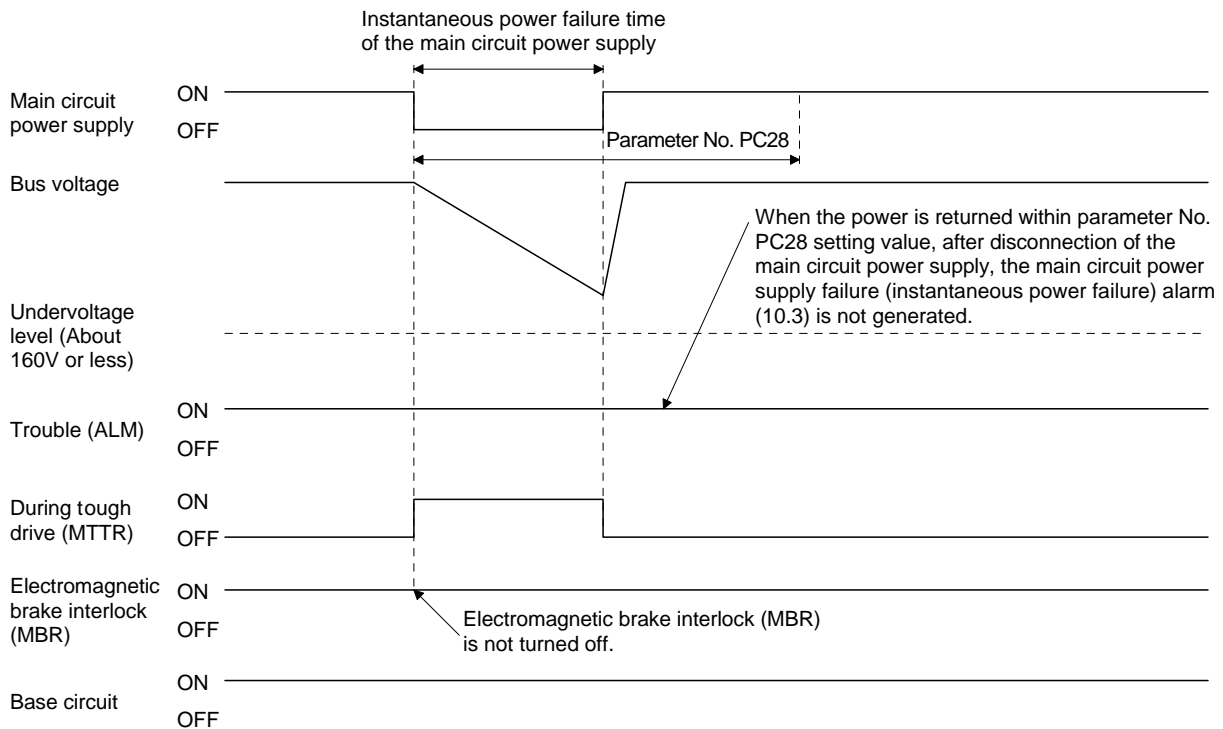

When the instantaneous power failure tough drive activates, the number of tough drive in the display mode (alarm mode) is increased by one. (Refer to section 5.5.)

7. SPECIAL ADJUSTMENT FUNCTIONS

(2) When an undervoltage occurs during the instantaneous main circuit power failure

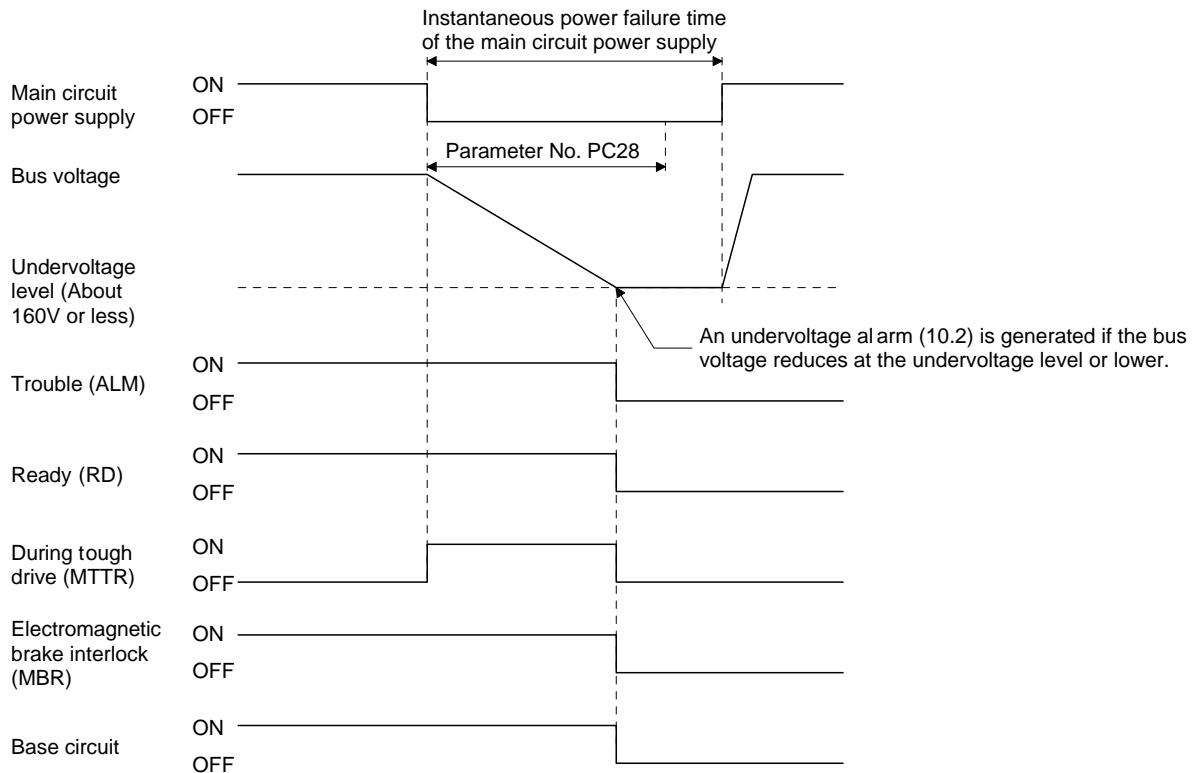

(3) When the instantaneous main circuit power failure time is longer than the set value of parameter No. PC28 (detailed setting of instantaneous power failure tough drive)

If the instantaneous main circuit power failure time exceeds the set value of parameter No. PC28, main circuit power supply failure (instantaneous power failure) alarm (10.3) occurs even if the instantaneous power failure tough drive function is valid.

7. SPECIAL ADJUSTMENT FUNCTIONS

7.2 Machine resonance suppression function

POINT

- The functions given in this section are not generally required to use. Use these functions when the machine status is not satisfactory after making adjustment in the methods given in chapter 6.

If a mechanical system has a natural resonance point, increasing the servo system response level may cause the mechanical system to produce resonance (vibration or unusual noise) at that resonance frequency. Using the machine resonance suppression filter and adaptive tuning can suppress the resonance of the mechanical system.

7.2.1 Function block diagram

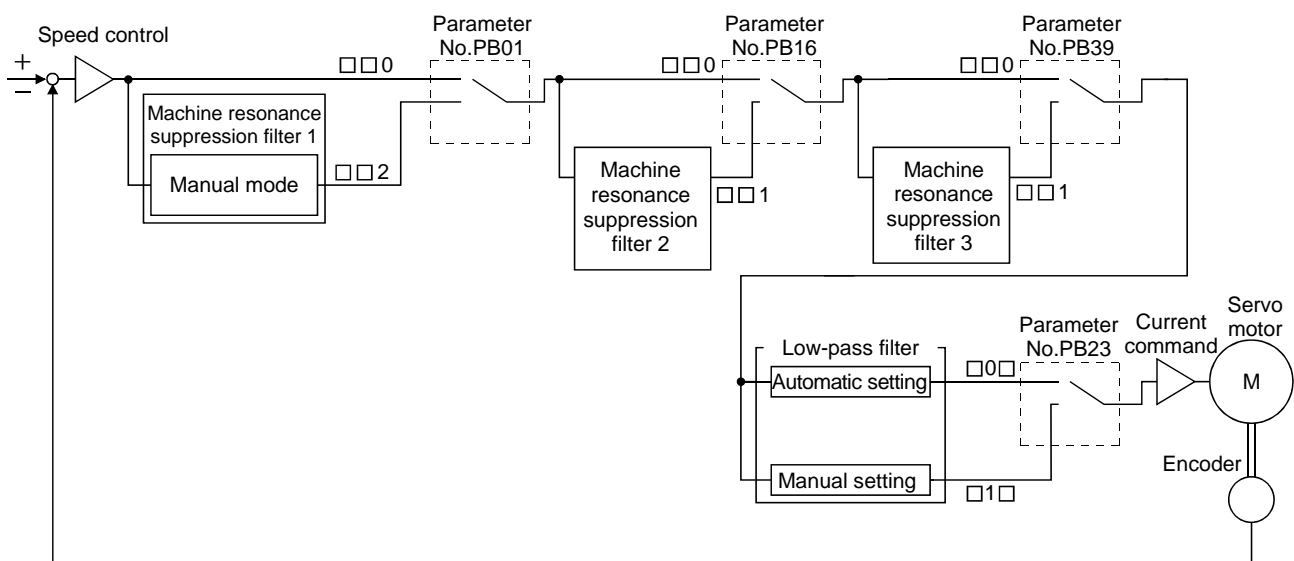

7.2.2 Adaptive filter II

(1) Function

The adaptive filter II (adaptive tuning) sets the filter characteristics automatically with the one-touch tuning, and suppresses vibrations of the mechanical system. Since the filter characteristics (frequency, depth) are set automatically, you need not be conscious of the resonance frequency of a mechanical system.

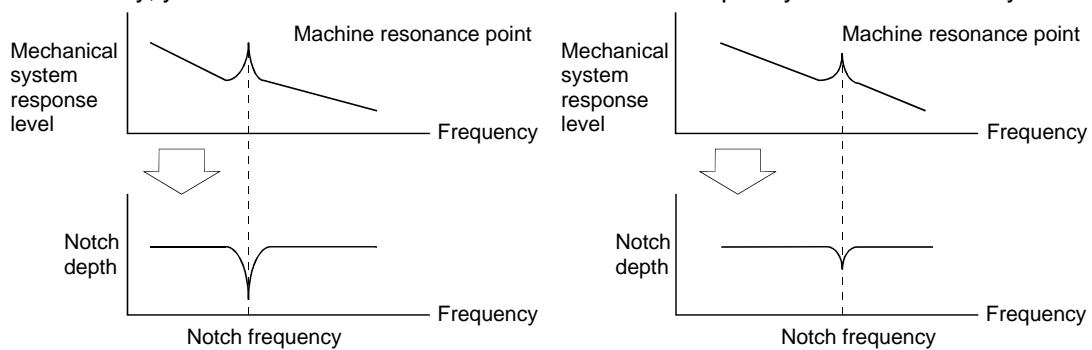

When machine resonance is large and frequency is low When machine resonance is small and frequency is high

7. SPECIAL ADJUSTMENT FUNCTIONS

POINT
<ul style="list-style-type: none"> ▪ When the one-touch tuning is performed, the adaptive tuning is performed, and the machine resonance suppression filter 1 (parameter No. PB13) and the notch shape selection 1 (parameter No. PB14) are set automatically. ▪ The machine resonance frequency which adaptive tuning mode can respond to is about 100 to 2.25kHz. Adaptive vibration suppression control has no effect on the resonance frequency outside this range. ▪ Adaptive vibration suppression control may provide no effect on a mechanical system which has complex resonance characteristics.

(2) Parameters

Select the tuning mode of adaptive tuning mode (parameter No. PB01).

Parameter No. PB01

0	0	
---	---	--

└─ Selection of adaptive tuning mode

Setting	Adaptive tuning mode	Manually set parameter No.
0	Filter OFF	(Note 1)
2(Note 2)	Manual mode	Parameter No. PB13 Parameter No. PB14

Note 1. Parameter No. PB13 and PB14 are fixed to the initial values.

2. When an adaptive filter is set, it is automatically updated to "2".

POINT
<ul style="list-style-type: none"> ▪ "Filter OFF" enables a return to the factory-set initial value. ▪ During adaptive tuning, a filter having the best notch depth at the set control gain is generated. To allow a filter margin against machine resonance, increase the notch depth in the manual mode.

7. SPECIAL ADJUSTMENT FUNCTIONS

7.2.3 Machine resonance suppression filter

(1) Function

The machine resonance suppression filter is a filter function (notch filter) which can suppress the resonance of the mechanical system by decreasing the gain of the specific frequency. You can set the gain decreasing frequency (notch frequency), gain decreasing depth and width.

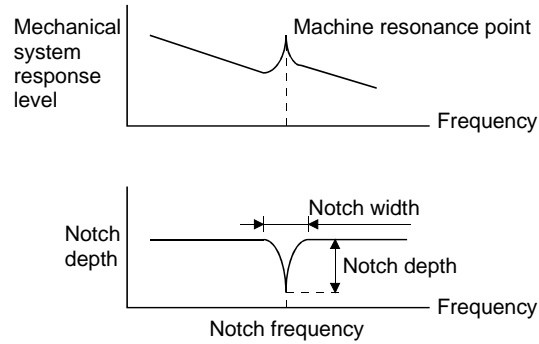

The vibration of three resonance frequency can be suppressed by the machine resonance suppression filter 1, machine resonance suppression filter 2 and machine resonance suppression filter 3.

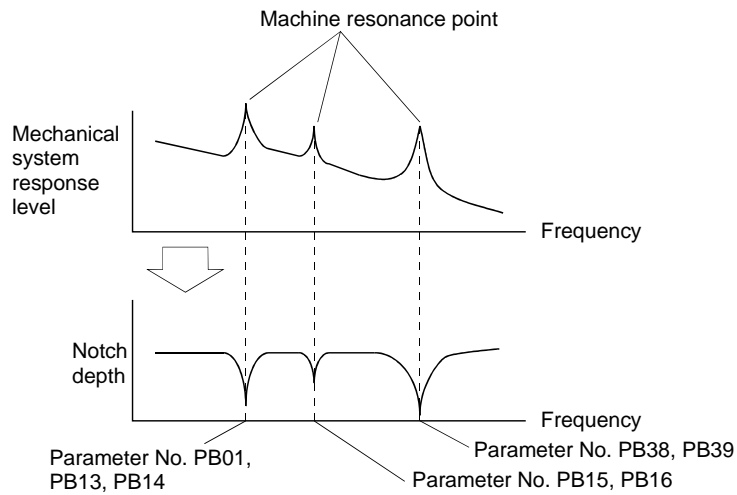

7. SPECIAL ADJUSTMENT FUNCTIONS

(2) Parameters

Set the machine resonance suppression filters by the parameters indicated in the following table.

Item	Parameters to be set		Note
	Notch frequency	Notch depth and width	
Machine resonance suppression filter 1	Parameter No. PB13	Parameter No. PB14	The set values are valid when "manual mode" is selected in the adaptive tuning mode (parameter No. PB01).
Machine resonance suppression filter 2	Parameter No. PB15	Parameter No. PB16	The set values are always valid regardless of the set value of the adaptive tuning mode (parameter No. PB01).
Machine resonance suppression filter 3	Parameter No. PB38	Parameter No. PB39	

POINT
<ul style="list-style-type: none"> ▪ The machine resonance suppression filter is a delay factor for the servo system. Hence, vibration may increase if an improper resonance frequency or an excessively deep notch is set. ▪ If the frequency of machine resonance is unknown, decrease the notch frequency from higher to lower. Set the notch frequency at the point where vibration is minimal. ▪ A deeper notch has a higher effect on machine resonance suppression but increases a phase delay and may increase vibration. ▪ A wider notch has a higher effect on machine resonance suppression but increases a phase delay and may increase vibration.

7.2.4 Advanced vibration suppression control

(1) Operation

Vibration suppression control is used to further suppress machine end vibration, such as workpiece end vibration and base shake. The motor side operation is adjusted for positioning so that the machine does not shake.

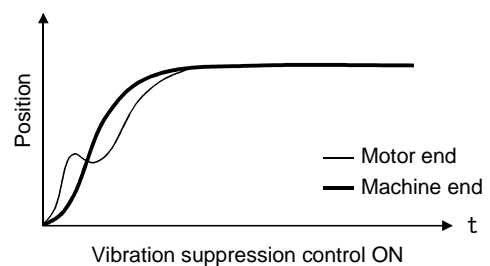
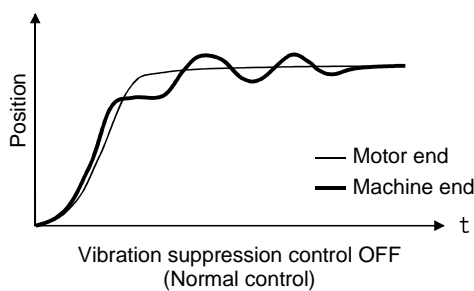

When the advanced vibration suppression control (vibration suppression control tuning mode (parameter No. PB02)) is executed, the vibration frequency at machine end can be automatically estimated to suppress machine end vibration.

In addition, the vibration suppression control tuning mode shifts to the manual mode after positioning is performed the predetermined number of times. The manual mode enables manual setting using the vibration suppression control vibration frequency setting (parameter No. PB19) and the vibration suppression control resonance frequency setting (parameter No. PB20).

7. SPECIAL ADJUSTMENT FUNCTIONS

(2) Parameter

Select the tuning mode of the vibration suppression control tuning mode (parameter No. PB02).

Parameter No. PB02

0	0	
---	---	--

Vibration suppression control tuning mode

Setting	Vibration suppression control tuning mode	Automatically set parameter
0	Vibration suppression control OFF	(Note)
1	Vibration suppression control tuning mode (Advanced vibration suppression control)	Parameter No. PB19 Parameter No. PB20
2	Manual mode	

Note. Parameter No. PB19 and PB20 are fixed to the initial values.

POINT
<ul style="list-style-type: none"> ▪ When executing the vibration suppression control tuning mode (advanced vibration suppression control), follow the procedures of (3) in this section. ▪ This function is valid when the auto tuning mode (parameter No. PA08) is set to manual mode ("□ □ 3"). ▪ The machine resonance frequency supported by the vibration suppression control tuning mode is 1.0Hz to 100.0Hz. The function is not effective for vibration outside this range. ▪ To prevent unexpected operations, be sure to stop the servo motor before changing the vibration suppression control-related parameters (parameter No. PB02, PB19, PB20, PB33, PB34, PB38, PB39). ▪ For positioning operation during execution of vibration suppression control tuning, provide a stop time to ensure a stop after full vibration damping. ▪ Vibration suppression control tuning may not make an estimation properly if the residual vibration at the motor end is small. ▪ Vibration suppression control tuning sets the optimum parameter with the currently set control gains. When the response setting is increased, set the vibration suppression control tuning again.

7. SPECIAL ADJUSTMENT FUNCTIONS

(3) Vibration suppression control tuning mode procedure

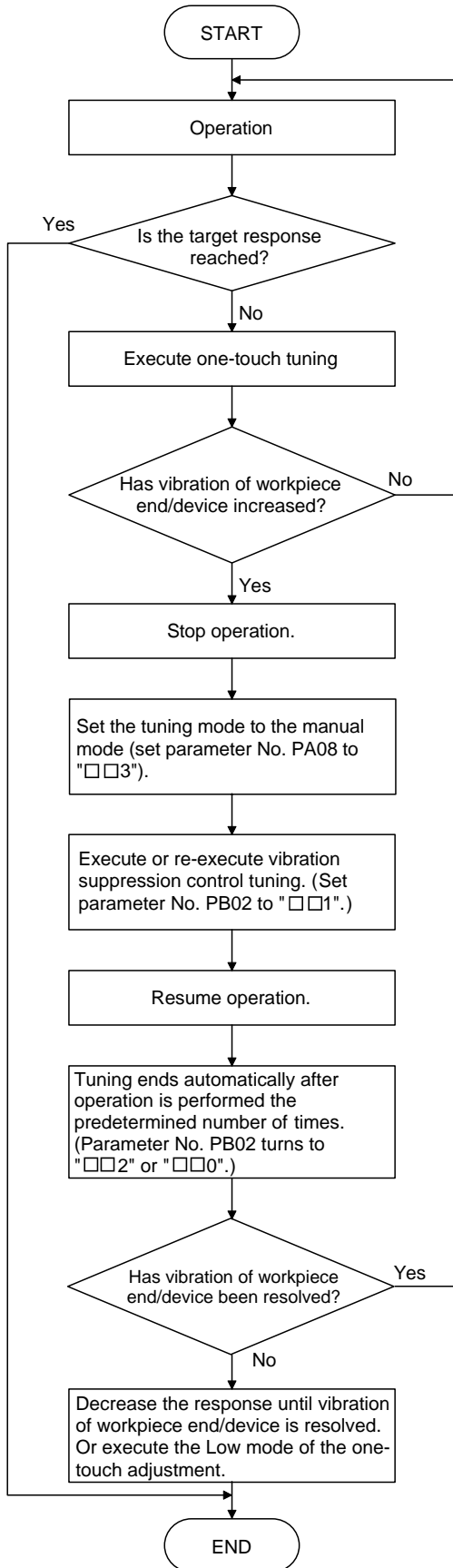

Factor

- Estimation cannot be made as machine end vibration has not been transmitted to the motor end.
- The response of the model loop gain has increased to the machine end vibration frequency (vibration suppression control limit).

7. SPECIAL ADJUSTMENT FUNCTIONS

(4) Vibration suppression control manual mode

Vibration suppression control can be set manually by setting the vibration suppression control vibration frequency (parameter No. PB19) and the vibration suppression control resonance frequency (parameter No. PB20) after measuring work-end vibration and device shake using an external measuring instrument.

(a) When a vibration peak can be measured using an external measuring instrument

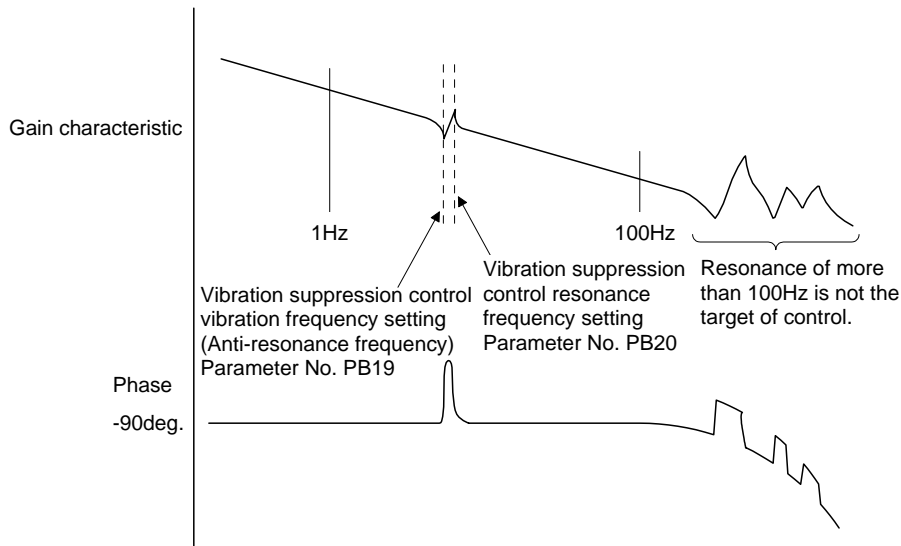

(b) When vibration can be measured using an external measuring instrument

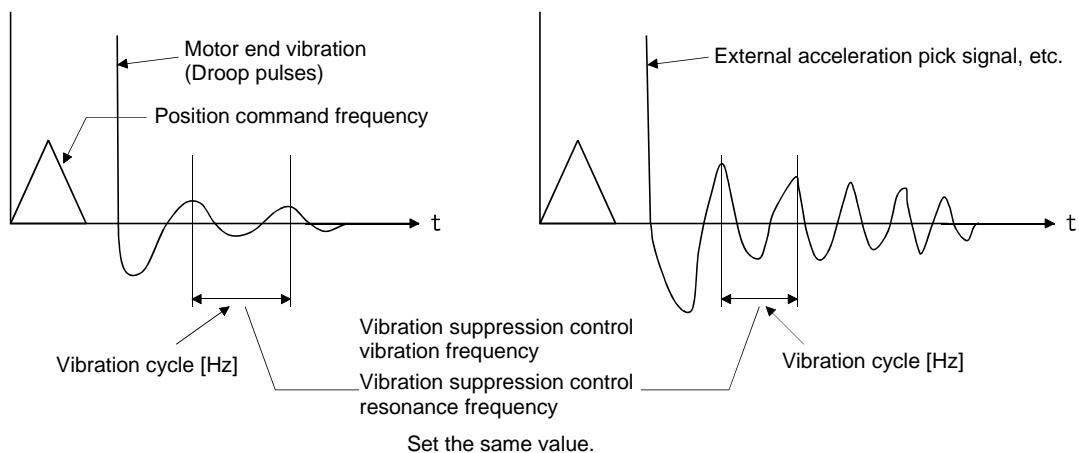

POINT
<ul style="list-style-type: none"> ▪ When the machine-end vibration does not travel to the motor end, setting the motor-end vibration frequency does not have any effect. ▪ When vibration frequency (anti-resonance frequency) and resonance frequency can be measured using an external measuring instrument, setting different values in parameters No. PB19 and No. 20 separately improves the vibration suppression performance better rather than setting the same value.

7. SPECIAL ADJUSTMENT FUNCTIONS

7.2.5 Low-pass filter

(1) Function

When a ballscrew or the like is used, resonance of high frequency may occur as the response level of the servo system is increased. To prevent this, the low-pass filter for a torque command is set valid. In the initial setting, the filter frequency of the low-pass filter is automatically adjusted to the value in the following expression.

$$\text{Filter frequency(rad/s)} = \frac{VG2}{1 + GD2} \times 10$$

When parameter No. PB23 is set to " □ 1 □ ", manual setting can be made by parameter No. PB18.

(2) Parameter

Set the low-pass filter selection (parameter No. PB23.)

Parameter No. PB23

0	□	0
---	---	---

Low-pass filter selection
0: Automatic setting (initial value)
1: Manual setting (parameter No. PB18 setting)

7.3 Gain changing function

POINT

- The functions given in this section are not generally required to use. Use these functions when the machine status is not satisfactory after making adjustment in the methods given in chapter 6.

This function can change the gains. Gains can be changed using an input device or gain switching conditions (servo motor speed, etc.)

7.3.1 Applications

This function is used when:

- (1) You want to increase the gains during servo lock but decrease the gains to reduce noise during rotation.
- (2) You want to increase the gains during settling to shorten the stop settling time.
- (3) You want to change the gains using an input device to ensure stability of the servo system since the load to motor inertia moment ratio varies greatly during a stop (e.g. a large load is mounted on a carrier).

7. SPECIAL ADJUSTMENT FUNCTIONS

7.3.2 Function block diagram

The valid loop gains PG2, VG2, VIC, GD2, VRF1 and VRF2 of the actual loop are changed according to the conditions selected by gain changing selection CDP (parameter No. PB26) and gain changing condition CDL (parameter No. PB27).

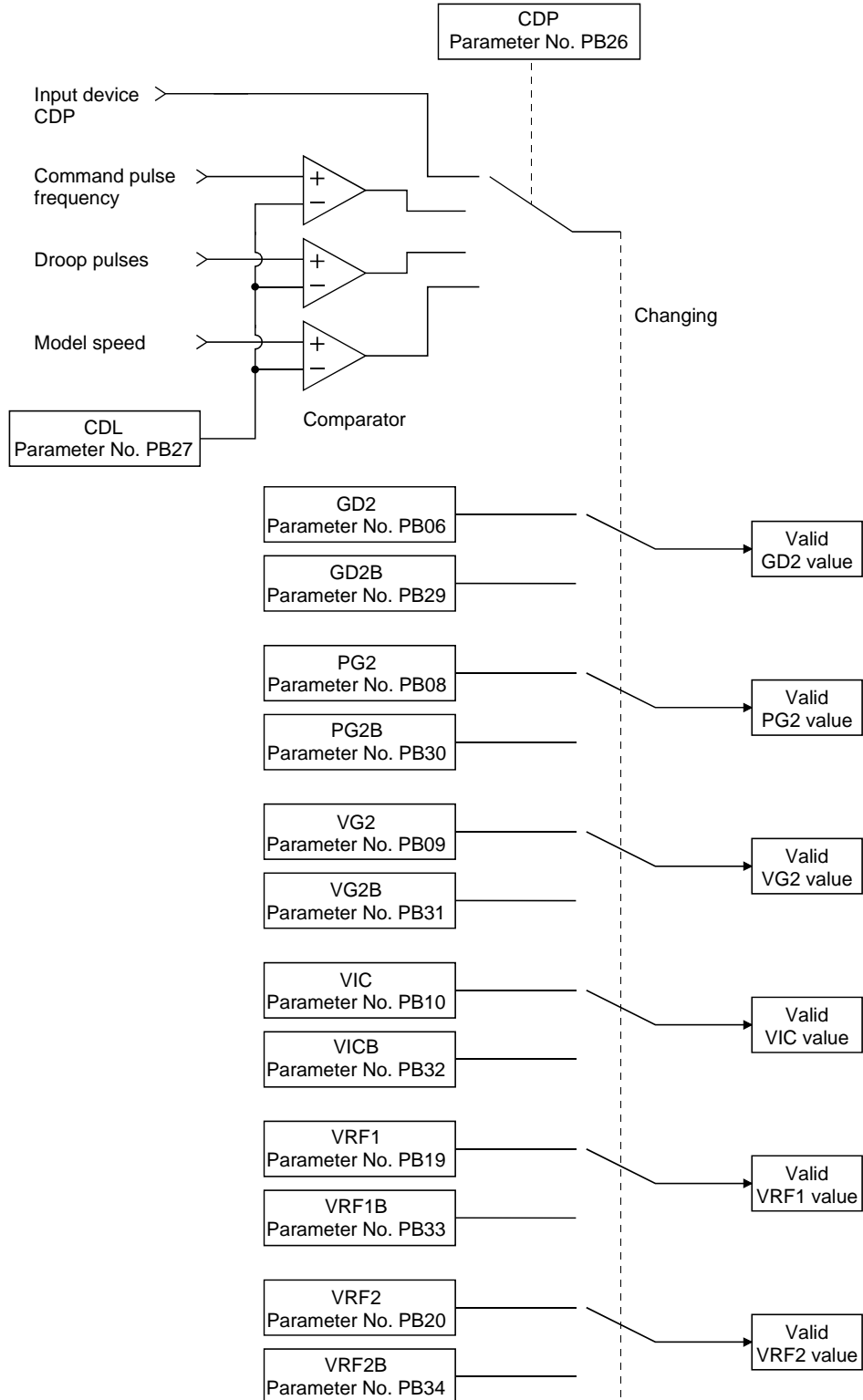

7. SPECIAL ADJUSTMENT FUNCTIONS

7.3.3 Parameters

When using the gain changing function, always set parameter No. PA08 (auto tuning mode) to "□□3" to select manual mode in the tuning mode. The gain changing function cannot be used in the auto tuning mode.

Parameter No.	Abbreviation	Name	Unit	Description
PB06	GD2	Load to motor inertia moment ratio	Multiplier (×1)	Control parameters before changing
PB07	PG1	Model loop gain	rad/s	Position and speed gains of a model used to set the response level to a command. Always valid.
PB08	PG2	Position loop gain	rad/s	
PB09	VG2	Speed loop gain	rad/s	
PB10	VIC	Speed integral compensation	ms	
PB29	GD2B	Gain changing load to motor inertia moment ratio	Multiplier (×1)	Used to set load to motor inertia moment ratio after changing.
PB30	PG2B	Gain changing position loop gain	rad/s	Used to set the value of the after-changing position loop gain.
PB31	VG2B	Gain changing speed loop gain	rad/s	Used to set the value of the after-changing speed loop gain.
PB32	VICB	Gain changing speed integral compensation	ms	Used to set the value of the after-changing speed integral compensation.
PB26	CDP	Gain changing selection		Used to select the changing condition.
PB27	CDL	Gain changing condition	kpps pulse r/min	Used to set the changing condition values.
PB28	CDT	Gain changing time constant	ms	Used to set the filter time constant for a gain change at changing.
PB33	VRF1B	Gain changing vibration suppression control vibration frequency setting	Hz	Used to set the value of the after-changing vibration suppression control vibration frequency setting.
PB34	VRF2B	Gain changing vibration suppression control resonance frequency setting	Hz	Used to set the value of the after-changing vibration suppression control resonance frequency setting.

(1) Parameters No. PB06 to PB10

These parameters are the same as in ordinary manual adjustment. Gain changing allows the values of load to motor inertia moment ratio, position loop gain, speed loop gain and speed integral compensation to be changed.

(2) Gain changing load to motor inertia moment ratio (parameter No. PB29)

This parameter is used to set load to motor inertia moment ratio after changing the gains. If the load to motor inertia moment ratio does not change, set the same value in this parameter as the load to motor inertia moment ratio (parameter No. PB06).

(3) Gain changing position loop gain (parameter No. PB30), gain changing speed loop gain (parameter No. PB31), gain changing speed integral compensation (parameter No. PB32).

This parameter is used to set the values of after-changing position loop gain, speed loop gain and speed integral compensation.

7. SPECIAL ADJUSTMENT FUNCTIONS

(4) Gain changing selection (parameter No. PB26)

This parameter is used to set the gain changing condition. Select the changing condition in the first and second digits. If "1" is set in the first digit, the gain can be changed by the gain changing (CDP) input device. The gain changing (CDP) can be assigned to CN1-3 pin to CN1-8 pin using parameters No. PD03 to PD14.

0		
---	--	--

Gain changing selection

Under any of the following conditions, the gains change on the basis of parameter No. PB29 to PB34 settings.

- 0: Invalid
- 1: Input device (gain changing (CDP))
- 2: Command frequency (parameter No. PB27 setting)
- 3: Droop pulse (parameter No. PB27 setting)
- 4: Servo motor speed (parameter No. PB27 setting)

Gain changing condition

- 0: Valid when the input device (gain changing (CDP)) is ON, or valid when the value is equal to or larger than the value set in parameter No. PB27.
- 1: Valid when the input device (gain changing (CDP)) is OFF, or valid when the value is equal to or smaller than the value set in parameter No. PB27.

(5) Gain changing condition (parameter No. PB27)

This parameter is used to set gain changing level when "command frequency", "droop pulse" or "servo motor speed" is selected in the gain changing selection (parameter No. PB26).

The setting unit is as follows.

Gain changing condition	Unit
Command frequency	kpps
Droop pulse	pulse
Servo motor speed	r/min

(6) Gain changing time constant (parameter No. PB28)

In this parameter, a primary delay filter can be set to each gain at gain changing. This parameter is, for example, used to prevent unexpected operation if the gain difference is large at gain changing.

(7) Gain changing vibration suppression control

Gain changing vibration suppression control is used only when the gain is changed by on/off of the input device (gain changing (CDP)).

7. SPECIAL ADJUSTMENT FUNCTIONS

7.3.4 Gain changing procedure

The operation is explained with setting examples below:

(1) When gain changing by an input device (CDP) is selected:

(a) Setting

Parameter No.	Abbreviation	Name	Setting	Unit
PB06	GD2	Load to motor inertia moment ratio	4.0	Multiplier (× 1)
PB07	PG1	Model loop gain	100	rad/s
PB08	PG2	Position loop gain	120	rad/s
PB09	VG2	Speed loop gain	3000	rad/s
PB10	VIC	Speed integral compensation	20	ms
PB19	VRF1	Vibration suppression control vibration frequency setting	50	Hz
PB20	VRF2	Vibration suppression control resonance frequency setting	50	Hz
PB29	GD2B	Gain changing load to motor inertia moment ratio	10.0	Multiplier (× 1)
PB30	PG2B	Gain changing position loop gain	84	rad/s
PB31	VG2B	Gain changing speed loop gain	4000	rad/s
PB32	VICB	Gain changing speed integral compensation	50	ms
PB26	CDP	Gain changing selection	001 (Changed by ON/OFF of input device)	
PB28	CDT	Gain changing time constant	100	ms
PB33	VRF1B	Gain changing vibration suppression control vibration frequency setting	60	Hz
PB34	VRF2B	Gain changing vibration suppression control resonance frequency setting	60	Hz

(b) Timing chart at changing

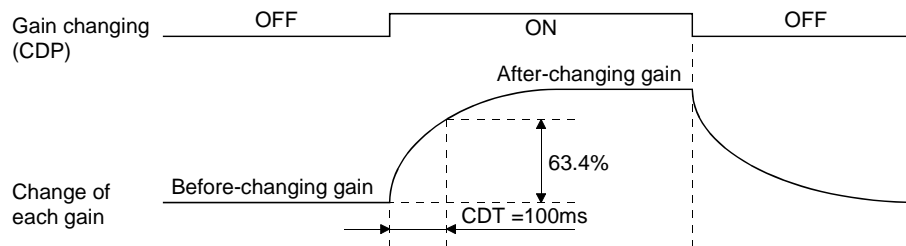

Model loop gain			100	
Load to motor inertia moment ratio	4.0	→	10.0	→ 4.0
Position loop gain	120	→	84	→ 120
Speed loop gain	3000	→	4000	→ 3000
Speed integral compensation	20	→	50	→ 20
Vibration suppression control vibration frequency setting	50	→	60	→ 50
Vibration suppression control resonance frequency setting	50	→	60	→ 50

7. SPECIAL ADJUSTMENT FUNCTIONS

(2) When gain changing by droop pulses is selected:

In this case, gain changing vibration suppression control cannot be used.

(a) Setting

Parameter No.	Abbreviation	Name	Setting	Unit
PB06	GD2	Load to motor inertia moment ratio	4.0	Multiplier (× 1)
PB07	PG1	Model loop gain	100	rad/s
PB08	PG2	Position loop gain	120	rad/s
PB09	VG2	Speed loop gain 2	3000	rad/s
PB10	VIC	Speed integral compensation	20	ms
PB29	GD2B	Gain changing load to motor inertia moment ratio	10.0	Multiplier (× 1)
PB30	PG2B	Gain changing position loop gain	84	rad/s
PB31	VG2B	Gain changing speed loop gain	4000	rad/s
PB32	VICB	Gain changing speed integral compensation	50	ms
PB26	CDP	Gain changing selection	003 (Changed by droop pulses)	
PB27	CDL	Gain changing condition	50	pulse
PB28	CDT	Gain changing time constant	100	ms

(b) Timing chart at changing

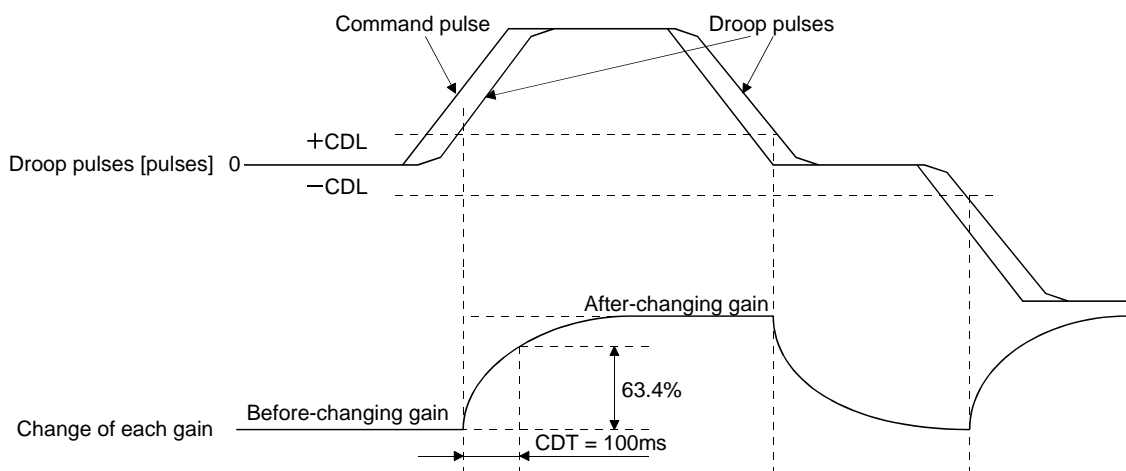

Model loop gain	100						
Load to motor inertia moment ratio	4.0	→	10.0	→	4.0	→	10.0
Position loop gain	120	→	84	→	120	→	84
Speed loop gain	3000	→	4000	→	3000	→	4000
Speed integral compensation	20	→	50	→	20	→	50

8. TROUBLESHOOTING

8. TROUBLESHOOTING

POINT
<ul style="list-style-type: none"> As soon as an alarm occurs, turn off servo-on (SON) and the main circuit power supply.

If an alarm/warning has occurred, refer to this chapter and remove its cause.

8.1 Alarms and warning list

When an error occurs during the operation, the corresponding alarm or warning is displayed. If any alarm or warning has occurred, refer to section 8.2 or 8.3 and take the appropriate action. When an alarm occurs, ALM turns off.

After removing the cause of the alarm, the alarm can be deactivated in any of the methods marked ○ in the alarm deactivation column.

The warning is automatically canceled after removing the cause of occurrence.

	No.	3-digit, 7-segment LED display	Name	Alarm deactivation		
				Power OFF→ON	Press "SET" on current alarm screen.	Alarm reset (RES)
Alarms	A.10	A.10	Undervoltage	○	○	○
	A.12	A.12	Memory error 1 (RAM)	○	○	○
	A.13	A.13	Clock error	○	○	○
	A.15	A.15	Memory error 2 (EEP-ROM)	○	○	○
	A.16	A.16	Encoder initial communication error1	○	○	○
	A.17	A.17	Board error	○	○	○
	A.19	A.19	Memory error 3 (Flash-ROM)	○	○	○
	A.1A	A.1A	Motor combination error	○	○	○
	A.1C	A.1C	Software combination error	○	○	○
	A.1E	A.1E	Encoder initial communication error 2	○	○	○
	A.1F	A.1F	Encoder initial communication error 3	○	○	○
	A.20	A.20	Encoder normal communication error 1	○	○	○
	A.21	A.21	Encoder normal communication error 2	○	○	○
	A.24	A.24	Main circuit error	○	○	○
	A.30	A.30	Regenerative error	(Note 1) ○	(Note 1) ○	(Note 1) ○
	A.31	A.31	Overspeed	○	○	○
	A.32	A.32	Overcurrent	○	○	○
	A.33	A.33	Overvoltage	○	○	○
	A.35	A.35	Command frequency error	○	○	○
	A.37	A.37	Parameter error	○	○	○
	A.39	A.39	Program error	○	○	○
	A.45	A.45	Main circuit device overheat	(Note 1) ○	(Note 1) ○	(Note 1) ○
	A.46	A.46	Servo motor overheat	(Note 1) ○	(Note 1) ○	(Note 1) ○
	A.50	A.50	Overload 1	(Note 1) ○	(Note 1) ○	(Note 1) ○
	A.51	A.51	Overload 2	(Note 1) ○	(Note 1) ○	(Note 1) ○
	A.52	A.52	Error excessive	○	○	○
	A.61	A.61	Operation alarm	○	○	○
	A.8E	A.8E	USB communication error	○	○	○
	888	888	Watchdog	○	○	○

8. TROUBLESHOOTING

	No.	3-digit, 7-segment LED display	Name	The servo motor stops /does not stop.
Warning	A.90	R90	Home positioning incomplete warning	Stops
	A.91	R91	Servo amplifier overheat warning	Does not stop
	A.96	R96	Home position setting error	Stops
	A.97	R97	Program operation disabled	Does not stop
	A.98	R98	Software limit warning	Stops (Note 2)
	A.99	R99	Stroke limit warning	Stops (Note 2)
	A.E0	RE0	Excessive regeneration warning	Does not stop
	A.E1	RE1	Overload warning 1	Does not stop
	A.E6	RE6	Servo forced stop warning	Stops
	A.E9	RE9	Main circuit off warning	Stops
	A.EC	REC	Overload warning 2	Does not stop
	A.ED	REd	Output watt excess warning	Does not stop
	A.F0	RFO	Tough drive warning	Does not stop

Note 1. Deactivate the alarm about 30 minutes of cooling time after removing the cause of occurrence.

2. Operation to the direction which cancels the warning can be performed.

8. TROUBLESHOOTING

8.2 Remedies for alarms

CAUTION

- When any alarm has occurred, eliminate its cause, ensure safety, then reset the alarm, and restart operation. Otherwise, injury may occur.
- As soon as an alarm occurs, turn off servo-on (SON) and the main circuit power supply. Otherwise, regenerative transistor fault or the like may overheat the regenerative resistor, causing a fire.

POINT

- When any of the following alarms has occurred, do not deactivate the alarm and resume operation repeatedly. To do so will cause the servo amplifier/servo motor to fail. Remove the cause of occurrence, and leave a cooling time of more than 30 minutes before resuming operation.
 - Regenerative error (30. □)
 - Main circuit device overheat (45.1)
 - Servo motor overheat (46.1)
 - Overload 1 (50. □)
 - Overload 2 (51. □)
- The alarm can be deactivated by switching the power off and then on, by pressing the "SET" button on the current alarm screen or by turning on the reset (RES). For details, refer to section 8.1.

When an alarm occurs, the trouble (ALM) switches off and the dynamic brake is operated to stop the servo motor. At this time, the display indicates the alarm No.

The following shows the display example of alarm 33 (overvoltage: detail1)

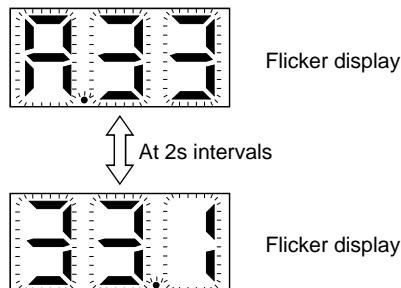

Remove the cause of the alarm in accordance with this section. Use MR Configurator to refer to a factor of alarm occurrence.

8. TROUBLESHOOTING

Alarm No.: A.10		Name: Undervoltage			
Description		<ul style="list-style-type: none"> ▪ Control circuit power supply voltage dropped. ▪ Main circuit power supply voltage dropped. ▪ Main circuit power supply is turned off. 			
Detailed display	Detailed Name	Cause	Checking method	Result	Action
10.1	Control circuit power supply voltage dropped	1) Control circuit power supply connector is disconnected. Contact failure.	Check the control circuit power supply connector.	The connector is disconnected or contact failure.	Connect correctly.
				No problem.	Check 2).
		2) Control circuit power supply voltage is low.	Check if the control circuit power supply voltage is 19VDC or less.	19VDC or less.	Raise the control circuit power supply voltage.
				Above 19VDC.	Check 3).
		3) Instantaneous power failure of 1ms or longer occurred.	Check for any problem with the power supply.	A problem is found.	Check the power supply.
		10.2	Main circuit power supply voltage dropped	1) Main circuit power supply connector is disconnected.	Check the main circuit power supply connector.
No problem.	Check 2).				
2) Main circuit power supply voltage is low.	Check if the main circuit power supply voltage is the following or less. MR-JN-□A: 140VAC MR-JN-□A1: 70VAC			MR-JN-□A: 140VAC or less MR-JN-□A1: 70VAC or less	Raise the main circuit power voltage.
				MR-JN-□A: Above 140VAC MR-JN-□A1: Above 70VAC	Check 3).
3) The drop occurs during acceleration.	Check if the value of status display Pn (bus voltage) is "1" (undervoltage).			The value is "1" (undervoltage).	Increase the acceleration time constant or the power supply capacity.
				The value is not "1" (undervoltage).	Check 4).
4) Servo amplifier fault	Check the value of status display Pn (bus voltage) when the main circuit power is on.			The value of the status display Pn (bus voltage) is "1" (overvoltage).	Replace the servo amplifier.
10.3	Main circuit power supply failure (instantaneous power failure)			1) Main circuit power supply connector/wire is disconnected.	Check the main circuit power connector.
		No problem.	Check 2).		
		2) Main circuit power supply voltage is low.	Check if the main circuit power supply voltage is the following or less. MR-JN-□A: 140VAC MR-JN-□A1: 70VAC	MR-JN-□A: 140VAC or less MR-JN-□A1: 70VAC or less	Raise the main circuit power supply voltage.
				MR-JN-□A: Above 140VAC MR-JN-□A1: Above 70VAC	Check 3).
		3) Instantaneous power failure of the main circuit power supply occurred.	Check the main circuit power supply.		

8. TROUBLESHOOTING

Alarm No.: A.12		Name: Memory error 1 (RAM)				
Description		▪ Servo amplifier internal part (CPU) is faulty.				
Detailed display	Detailed Name	Cause	Checking method	Result	Action	
12.1	CPU built-in RAM fault	1)	Faulty parts in the servo amplifier	Remove all cables except for the control circuit power supply and check if the alarm occurs.	Alarm occurs.	Replace the servo amplifier.
					Alarm does not occur.	Check 2).
		2)	Fault in the surrounding environment	Check if any noise entered the power supply. Check if any connector is shorted.	An error is found.	Take the appropriate measures according to the cause.

Alarm No.: A.13		Name: Clock error				
Description		▪ Printed board fault ▪ CPU clock fault				
Detailed display	Detailed Name	Cause	Checking method	Result	Action	
13.1	Clock error	1)	Printed board fault	Remove all cables except for the control circuit power supply and check if the alarm occurs.	Alarm occurs.	Replace the servo amplifier.
		2)	Parts fault		Alarm does not occur.	Check 3).
		3)	Fault in the surrounding environment	Check if any noise entered the power supply. Check if any connector is shorted.	An error is found.	Take the appropriate measures according to the cause.

Alarm No.: A.15		Name: Memory error 2 (EEP-ROM)				
Description		▪ Servo amplifier internal part (EEP-ROM) is faulty.				
Detailed display	Detailed Name	Cause	Checking method	Result	Action	
15.1	EEP-ROM error at power-on	1)	EEP-ROM operation fault when the power is on.	Remove all cables except for the control circuit power supply and check if the alarm occurs.	Alarm occurs.	Replace the servo amplifier.
					Alarm does not occur.	Check 2).
		2)	Fault in the surrounding environment	Check if any noise entered the power supply. Check if any connector is shorted.	An error is found.	Take the appropriate measures according to the cause.
				No error.	Replace the servo amplifier.	
15.2	EEP-ROM error during operation	1)	EEP-ROM operation fault during the normal operation	Check if the alarm occurs when the parameter is changed during the normal operation.	Alarm occurs.	Replace the servo amplifier.

8. TROUBLESHOOTING

Alarm No.: A.16		Name: Encoder initial communication error 1				
Description		▪ Communication error occurred between the encoder and the servo amplifier.				
Detailed display	Detailed Name	Cause	Checking method	Result	Action	
16.0	Encoder transmission data error	1)	Encoder cable faulty	Check the shield status.	Error in the shield.	Repair the cable.
					No error in the shield.	Check 2).
		2)	Fault in the surrounding environment	Check the noise, the ambient temperature, etc.	An error is found.	Take the appropriate measures according to the cause.
					No error.	Check 3).
		3)	Servo amplifier fault	Check if the alarm occurs again.	Alarm occurs.	Replace the servo amplifier.
					Alarm does not occur.	Execute the checking methods mentioned in the alarm display "16.3".
16.1	Encoder transmission data error 1 (Servo amplifier receive error)	1)	Encoder cable faulty	Execute the checking methods mentioned in the alarm display "16.0".		
		2)	Fault in the surrounding environment			
		3)	Servo amplifier fault			
16.2	Encoder transmission data error 2 (Frame error)	1)	Encoder cable faulty	Execute the checking methods mentioned in the alarm display "16.0".		
		2)	Fault in the surrounding environment			
		3)	Servo amplifier fault			
16.3	Encoder transmission data error 3 (The servo amplifier not receiving)	1)	Encoder cable is disconnected.	Check if the encoder cable is connected correctly.	Disconnected.	Connect correctly.
					Connected correctly.	Check 2).
		2)	Encoder cable faulty	Check if the encoder cable is disconnected or shorted. Check the shield status.	An error is found.	Repair or replace the cable.
					No error.	Check 3).
		3)	Encoder cable type (2-wire, 4-wire) selection is incorrect in the parameter setting.	Check the set value of parameter No.PC22. 2-wire: "0 □ □" 4-wire: "1 □ □"	Incorrect set value is set.	Set correctly.
					No problem.	Check 4).
		4)	Encoder fault	Check if the alarm occurs after replacing the servo motor.	Alarm does not occur.	Replace the servo motor.
					Alarm occurs.	Check 5).
		5)	Servo amplifier fault	Check if the alarm occurs after replacing the servo amplifier.	Alarm does not occur.	Replace the servo amplifier.
					Alarm occurs.	Check 6).
		6)	Fault in the surrounding environment	Check the noise, etc.	An error is found.	Take the appropriate measures according to the cause.

8. TROUBLESHOOTING

Alarm No.: A.16		Name: Encoder initial communication error 1				
Description		▪ Communication error occurred between the encoder and the servo amplifier.				
Detailed display	Detailed Name	Cause	Checking method	Result	Action	
16.5	Encoder receive data error 1 (Parity error)	1)	Encoder cable faulty	Check the shield status.	Error in the shield.	Repair the cable.
					No error in the shield.	Check 2).
		2)	Fault in the surrounding environment	Check the noise, etc.	An error is found.	Take the appropriate measures according to the cause.
					No error.	Check 3).
3)	Encoder fault	Check if the alarm occurs after replacing the servo motor.	Alarm does not occur.	Replace the servo motor.		
16.6	Encoder receive data error 2 (Frame error)	1)	Encoder cable faulty	Execute the checking methods mentioned in the alarm display "16.5".		
		2)	Fault in the surrounding environment			
		3)	Encoder fault			
16.7	Encoder receive data error 3 (Request discrepancy)	1)	Encoder cable faulty	Execute the checking methods mentioned in the alarm display "16.5".		
		2)	Fault in the surrounding environment			
		3)	Encoder fault			

Alarm No.: A.17		Name: Board error				
Description		▪ Servo amplifier internal part is faulty.				
Detailed display	Detailed Name	Cause	Checking method	Result	Action	
17.1	AD converter error	1)	Current detection circuit fault	Turn off the servo-on (SON) and check if the alarm occurs.	Alarm occurs.	Replace the servo amplifier.
					Alarm does not occur.	Check 2).
		2)	Fault in the surrounding environment	Check the noise, the ambient temperature, etc.	An error is found.	Take the appropriate measures according to the cause.
17.2	Current feedback data error	1)	Current detection circuit fault	Execute the checking methods mentioned in the alarm display "17.1".		
		2)	Fault in the surrounding environment			
17.3	Custom IC error	1)	Current detection circuit fault			
		2)	Fault in the surrounding environment			
17.4	Servo amplifier identification signal error	1)	Servo amplifier identification signal could not be read correctly.	Remove all cables except for the control circuit power supply and check if the alarm occurs.	Alarm occurs.	Replace the servo amplifier.

8. TROUBLESHOOTING

Alarm No.: A.19		Name: Memory error 3 (Flash ROM)			
Description		▪ Servo amplifier internal part (Flash-ROM) is faulty.			
Detailed display	Detailed Name	Cause	Checking method	Result	Action
19.1	Flash-ROM error1	1) Flash-ROM fault	Remove all cables except for the control circuit power supply and check if the alarm occurs.	Alarm occurs.	Replace the servo amplifier.
19.2	Flash-ROM error2	1) Flash-ROM fault	Execute the checking methods mentioned in the alarm display "19.1".		

Alarm No.: A.1A		Name: Motor combination error			
Description		▪ Incorrect combination of servo amplifier and servo motor.			
Detailed display	Detailed Name	Cause	Checking method	Result	Action
1A.1	Motor combination error	1) Incorrect combination of servo amplifier and servo motor is connected.	Check the model of the servo motor and the combination with the servo amplifier.	Incorrect combination.	Use correct combination.

Alarm No.: A.1C		Name: Software combination error			
Description		▪ Software checksum error			
Detailed display	Detailed Name	Cause	Checking method	Result	Action
1C.1	Software combination error	1) Flash-ROM fault	Remove all cables except for the control circuit power supply and check if the alarm occurs.	Alarm occurs.	Replace the servo amplifier.

Alarm No.: A.1E		Name: Encoder initial communication error 2			
Description		▪ Faulty parts in the encoder			
Detailed display	Detailed Name	Cause	Checking method	Result	Action
1E.1	Encoder fault	1) Encoder fault	Check if the alarm occurs after replacing the servo motor.	Alarm does not occur.	Replace the servo motor.
		2) Fault in the surrounding environment		Check the noise, the ambient temperature, etc.	Alarm occurs. An error is found.

Alarm No.: A.1F		Name: Encoder initial communication error 3			
Description		▪ Incompatible encoder is connected.			
Detailed display	Detailed Name	Cause	Checking method	Result	Action
1F.1	Incompatible encoder	1) Incompatible servo motor (encoder) is connected with the servo amplifier.	Check the model of servo motor.	Servo motor is incompatible.	Replace the servo motor.

8. TROUBLESHOOTING

Alarm No.: A.20		Name: Encoder normal communication error 1			
Description		▪ Communication error occurred between the encoder and the servo amplifier.			
Detailed display	Detailed Name	Cause	Checking method	Result	Action
20.1	Encoder transmission data error (Servo amplifier receive error)	1) Encoder cable is disconnected.	Check if the encoder cable is connected correctly.	Disconnected.	Connect correctly.
				Connected correctly.	Check 2).
		2) Encoder cable faulty	Check if the encoder cable is disconnected or shorted.	An error is found.	Repair or replace the cable.
				No error.	Check 3).
		3) Encoder cable shielding is faulty	Check the shield status.	An error is found.	Repair the cable.
	No error.	Check 4).			
4) Servo amplifier fault	Check if the alarm occurs after replacing the servo amplifier.	Alarm does not occur.	Replace the servo amplifier.		
		Alarm occurs.	Check 5).		
	5) Fault in the surrounding environment	Check the external noise, the ambient temperature, etc.	An error is found.	Take the appropriate measures according to the cause.	
20.5	Encoder receive data error 1 (Frame error)	1) Encoder cable shielding is faulty	Check the shield status.	An error is found.	Repair the cable.
				No error.	Check 2).
		2) Fault in the surrounding environment	Check the noise, etc.	An error is found.	Take the appropriate measures according to the cause.
				No error.	Check 3).
3) Encoder fault	Check if the alarm occurs after replacing the servo motor.	Alarm does not occur.	Replace the servo motor.		
20.7	Encoder receive data error2 (Request discrepancy)	1) Encoder cable shielding is faulty	Execute the checking methods mentioned in the alarm display "20.5".		
		2) Fault in the surrounding environment			
		3) Encoder fault			

Alarm No.: A.21		Name: Encoder normal communication error 2			
Description		▪ Encoder data fault			
Detailed display	Detailed Name	Cause	Checking method	Result	Action
21.1	Encoder data error	1) Excessive acceleration is detected by oscillation, etc.	Check if the alarm occurs after the loop gain is decreased.	Alarm does not occur.	Operate with the loop gain decreased.
				Alarm occurs.	Check 2).
		2) Fault in the surrounding environment	Check the noise, etc.	An error is found.	Take the appropriate measures according to the cause.
				No error.	Check 3).
		3) Encoder fault	Check if the alarm occurs after replacing the servo motor.	Alarm does not occur.	Replace the servo motor.
21.2	Encoder data updating error	1) Encoder fault	Check if the alarm occurs after replacing the servo motor.	Alarm does not occur.	Replace the servo motor.
21.3	Encoder waveform error	1) Encoder fault	Check if the alarm occurs after replacing the servo motor.	Alarm does not occur.	Replace the servo motor.

8. TROUBLESHOOTING

Alarm No.: A.24		Name: Main circuit error			
Description		<ul style="list-style-type: none"> ▪ Ground fault occurred in the servo motor power cables. ▪ Ground fault occurred in the servo motor 			
Detailed display	Detailed Name	Cause	Checking method	Result	Action
24.1	Ground fault detected by the hardware detection circuit	1) Servo amplifier fault	Alarm occurs even if the power cables (U, V, W) are disconnected.	Alarm occurs.	Replace the servo amplifier.
				Alarm does not occur.	Check 2).
		2) Ground fault or short of the servo motor power cables	Check if the power cables themselves (between U, V, W and \oplus) are shorted.	Cables are shorted.	Replace the power cables.
				No problem.	Check 3).
		3) Ground fault in the servo motor	Remove the power cables from the servo motor and check if short occurs in the servo motor (between U, V, W and \oplus).	Servo motor is shorted.	Replace the servo motor.
				No problem.	Check 4).
		4) Power supply cables and servo motor power cables are shorted.	Check if there is a contact between the power supply cables and the servo motor power cables at power-off.	There is a contact.	Connect correctly.
				No contact.	Check 5).
		5) Fault in the surrounding environment	Check the noise, etc.	An error is found.	Take the appropriate measures according to the cause.
		24.2	Ground fault detected by the software detection	1) Servo amplifier fault	Execute the checking methods mentioned in the alarm display "24.1".
2) Ground fault or short of the servo motor power cables					
3) Ground fault in the servo motor					
4) Power supply cables and servo motor power cables are shorted.					
5) Fault in the surrounding environment					

8. TROUBLESHOOTING

Alarm No.: A.30		Name: Regenerative error				
Description		<ul style="list-style-type: none"> ▪ Permissible regenerative power of the built-in regenerative resistor or the regenerative option is exceeded. ▪ Regenerative transistor faulty in the servo amplifier. 				
Detailed display	Detailed Name	Cause	Checking method	Result	Action	
30.1	Regenerative heat generation error	1)	Incorrect setting of the built-in regenerative resistor (regenerative option)	Check the built-in regenerative resistor (regenerative option) being used and the set value of parameter No. PA02.	The set value is incorrect.	Set correctly.
					The set value is correct.	Check 2).
		2)	Built-in regenerative resistor (regenerative option) is disconnected.	Check if the built-in regenerative resistor (regenerative option) is connected correctly.	Incorrect connection.	Connect correctly.
					Correct connection.	Check 3).
		3)	Power supply voltage is high.	Check the input power supply.	230VAC or more.	Decrease the power supply voltage.
			Below 230VAC.	Check 4).		
		4)	The regenerative load ratio is over 100%.	Call the status display or MR Configurator and check the regenerative load ratio at alarm occurrence.	100% or more.	Reduce the frequency of positioning. Increase the deceleration time constant. Reduce the load. Use the regenerative option if it is not used.
30.2	Regenerative transistor fault	1)	Regenerative transistor is faulty.	Check if the built-in regenerative resistor (regenerative option) is overheated abnormally.	Overheated abnormally.	Replace the servo amplifier.
30.3	Regenerative transistor feedback data error	1)	Servo amplifier detection circuit is faulty	Remove the wiring of P and C, and execute the operation.	Alarm occurs.	Replace the servo amplifier.

8. TROUBLESHOOTING

Alarm No.: A.31		Name: Overspeed				
Description		▪ Servo motor speed has exceeded the instantaneous permissible speed.				
Detailed display	Detailed Name	Cause	Checking method	Result	Action	
31.1	Motor speed error	1)	Command speed is high.	Check if the command speed is at the permissible speed or higher.	The command speed is at the permissible speed or higher.	Check the operation pattern.
					The command speed is lower than the permissible speed.	Check 2).
		2)	Servo motor operates with the maximum torque, and speed overshoot occurs.	Check if the acceleration torque is the maximum.	Performed with the maximum torque.	Increase the acceleration/deceleration time constant, or reduce the load.
					Performed with the torque lower than the maximum.	Check 3).
		3)	Servo system is instable and oscillating.	Check if the servo motor is oscillating.	Servo motor is oscillating.	Adjust the servo gain by the auto tuning 1 or the one-touch tuning. Reduce the load.
					Servo motor is not oscillating.	Increase the acceleration time constant. Check 4).
		4)	The overshoot of speed waveform occurs.	Check if the overshoot occurs due to saturated torque caused by short acceleration time constant.	Overshoot occurs.	Increase the acceleration/deceleration time constant.
					Overshoot does not occur.	Check 5).
		5)	Encoder faulty.	Check if the alarm occurs when the actual speed is under the instantaneous permissible speed.	Alarm occurs.	Replace the servo motor.

Alarm No.: A.32		Name: Overcurrent				
Description		▪ The flowed current is higher than the permissible current of the servo amplifier.				
Detailed display	Detailed Name	Cause	Checking method	Result	Action	
32.1	Overcurrent was detected by the hardware detection circuit (during operation)	1)	Servo amplifier fault	Check if the alarm occurs even if the power cables (U, V, W) are disconnected.	Alarm occurs.	Replace the servo amplifier.
					Alarm does not occur.	Check 2).
		2)	Ground fault or short of the servo motor power cables	Check if the power cables themselves are shorted.	Cables are shorted.	Replace the power cables.
					No problem.	Check 3).
		3)	Servo motor fault	Remove the power cables from the servo motor edge and check if short occurs (between U, V, W and \ominus).	Ground fault occurs in the servo motor.	Replace the servo motor.
					Ground fault does not occur in the servo motor.	Check 4).
		4)	Fault in the surrounding environment	Check the noise, etc.	An error is found.	Take the appropriate measures according to the cause.

8. TROUBLESHOOTING

Alarm No.: A.32		Name: Overcurrent			
Description		▪ The flowed current is higher than the permissible current of the servo amplifier.			
Detailed display	Detailed Name	Cause	Checking method	Result	Action
32.2	Overcurrent was detected by the software detection (during operation)	1) High servo gain	Check if the oscillation occurs.	Oscillation occurs.	Decrease the speed loop gain.
				Oscillation does not occur.	Check 2).
		2) Servo amplifier fault	Check if the alarm occurs even if the power cables (U, V, W) are disconnected.	Alarm occurs.	Replace the servo amplifier.
				Alarm does not occur.	Check 3).
		3) Ground fault or short of the servo motor power cables	Check if the power cables themselves are shorted.	Cables are shorted.	Replace the power cables.
				No problem.	Check 4).
		4) Servo motor fault	Remove the power cables from the servo motor edge and check if short occurs (between U, V, W and \ominus).	Ground fault occurs in the servo motor	Replace the servo motor.
				Ground fault does not occur in the servo motor	Check 5).
		5) Fault in the surrounding environment	Check the noise, etc.	An error is found.	Take the appropriate measures according to the cause.
		32.3	Overcurrent was detected by the hardware detection circuit (during a stop)	1) Servo amplifier fault	Execute the checking methods mentioned in the alarm display "32.1".
2) Ground fault or short of the servo motor power cables					
3) Servo motor fault					
4) Fault in the surrounding environment					
32.4	Overcurrent was detected by the software detection (during a stop)	1) High servo gain	Execute the checking methods mentioned in the alarm display "32.2".		
		2) Servo amplifier fault			
		3) Ground fault or short of the servo motor power cables			
		4) Servo motor fault			
		5) Fault in the surrounding environment			

8. TROUBLESHOOTING

Alarm No.: A.33		Name: Overvoltage			
Description		▪ The value of the status display Pn (bus voltage) is "5" (overvoltage).			
Detailed display	Detailed Name	Cause	Checking method	Result	Action
33.1	Main circuit voltage error	1) The regenerative option is used, but the set value of the parameter is not correct.	Check the set value of parameter No.PA02.	Incorrect setting.	Correct the set value.
				Correct setting.	Check 2).
		2) Regenerative option is not used. Lead of the built-in regenerative resistor or the regenerative option is open or disconnected.	Check the wiring and the lead of the built-in regenerative resistor (regenerative option).	Open or disconnected.	Connect correctly.
				No problem.	Check 3).
		3) Check the built-in regenerative resistor (regenerative option).	Check the resistance value.	Error in the built-in regenerative resistor (regenerative option).	When using the built-in regenerative resistor, replace the servo amplifier. When using the regenerative option, replace the regenerative option.
				No problem.	Check 4).
		4) Regenerative capacity is insufficient.	Check if alarm occurs when the deceleration time constant is increased.	Alarm does not occur.	Use the regenerative option if it is not used. Increase the deceleration time constant.
				Alarm occurs.	Check 5).
		5) Main circuit power supply voltage is high.	Check if the main circuit power supply voltage is the following or above. MR-JN-□A: 253VAC MR-JN-□A1: 132VAC	MR-JN-□A: Above 253VAC MR-JN-□A1: Above 132VAC	Reduce the main circuit power supply voltage.
				MR-JN-□A: 253VAC or less MR-JN-□A1: 132VAC or less	Check 6).
		6) Main circuit power supply voltage is high. (A servo amplifier for 1-phase 100VAC input is used in the 200VAC power supply circuit.)	Check the model of servo amplifier.	The model of servo amplifier is "MR-JN-□A1".	The servo amplifier may malfunction due to the voltage input different from the power specification. Replace the servo amplifier with a "MR-JN-□A" model.

8. TROUBLESHOOTING

Alarm No.: A.35		Name: Command frequency error				
Description		▪ Input command frequency is too high.				
Detailed display	Detailed Name	Cause	Checking method	Result	Action	
35.1	Command frequency error	1)	Command frequency is 1.5 times or more of the maximum command pulse frequency.	<ul style="list-style-type: none"> ▪ Check the speed command. ▪ Check the set value of parameter No.PA13 (command input pulse form). "0 □ □": The command pulse frequency is 1Mpps or less. "1 □ □": The command pulse frequency is 500kpps or less. "2 □ □": The command pulse frequency is 200kpps or less. 	The set value of the speed command is high.	Check operation pattern.
					The set value of the speed command is within the range.	Check the set value of parameter No.PA13.
		2)	Servo amplifier fault	Check if the alarm occurs after replacing the servo motor.	Alarm does not occur.	Replace the servo amplifier.
					Alarm occurs.	Check 2).
					An error is found.	Take the appropriate measures according to the cause.
		3)	Fault in the surrounding environment	Check the noise, the ambient temperature, etc.		

Alarm No.: A.37		Name: Parameter error				
Description		▪ Parameter setting is incorrect.				
Detailed display	Detailed Name	Cause	Checking method	Result	Action	
37.1	Parameter setting range error	1)	Parameter is set outside the setting range.	Check the set value according to the parameter error No.	Outside the setting range.	Correct the value within the setting range.
				Within the setting range.	Check 2).	
		2)	EEP-ROM fault	Write the parameter set value within the normal range, and check if the value is written correctly.	Abnormal value is written.	Replace the servo amplifier.
					Normal value is written.	Check 3).
		3)	Servo amplifier fault causes the change in the parameter setting.	Check if the alarm occurs after replacing the servo amplifier.	Alarm does not occur.	Replace the servo amplifier.
		37.2	Parameter combination error	1) Unavailable parameter combination is set.	Check the set value according to the parameter error No.	The set value is incorrect.

8. TROUBLESHOOTING

Alarm No.: A.37		Name: Parameter error				
Description		▪ Parameter setting is incorrect.				
Detailed display	Detailed Name	Cause	Checking method	Result	Action	
37.3	Point table setting range error	1)	Point table is set outside the setting range.	Check the set value according to the point table error No.	Outside the setting range.	Correct the value within the setting range.
					Within the setting range.	Check 2).
		2)	EEP-ROM fault	Write the point table set value within the normal range, and check if the value is written correctly.	Abnormal value is written.	Replace the servo amplifier.
					Normal value is written.	Check 3).
		3)	Servo amplifier fault causes the change in the point table setting.	Check if the alarm occurs after replacing the servo amplifier.	Alarm does not occur.	Replace the servo amplifier.

Alarm No.: A.39		Name: Program error				
Description		▪ The program is incorrect.				
Detailed display	Detailed Name	Cause	Checking method	Result	Action	
39.1	Program error	1)	A program command was rewritten.	Check the program.	The program is different.	Correct the program.
					The program is correct.	Check 2).
		2)	EEP-ROM fault by the exceeded number of program write times	Write a correct program, and check if the program is written correctly.	Incorrect program is written.	Replace the servo amplifier.
					Correct program is written.	Check 3).
		3)	Servo amplifier fault caused the program to be rewritten.	Check if the alarm occurs after replacing the servo amplifier.	Alarm does not occur.	Replace the servo amplifier.
		39.2	Command argument range error	1)	An argument of program command is out of the range.	Check the command argument according to the step No. (Refer to section 5.3.1.)
Within the argument range	Check 2).					
2)	EEP-ROM fault by the exceeded number of program write times			Write a correct program, and check if the program is written correctly.	Incorrect program is written.	Replace the servo amplifier.
					Correct program is written.	Check 3).
3)	Servo amplifier fault caused the program to be rewritten.			Check if the alarm occurs after replacing the servo amplifier.	Alarm does not occur.	Replace the servo amplifier.
39.3	Incompatible command			1)	A program command is incompatible.	Check the command according to the step No. (Refer to section 5.3.1.)
		Compatible command	Check 2).			
		2)	EEP-ROM fault by the exceeded number of program write times	Write a correct program, and check if the program is written correctly.	Incorrect program is written.	Replace the servo amplifier.
					Correct program is written.	Check 3).
		3)	Servo amplifier fault caused the program to be rewritten.	Check if the alarm occurs after replacing the servo amplifier.	Alarm does not occur.	Replace the servo amplifier.

8. TROUBLESHOOTING

Alarm No.: A.45		Name: Main circuit device overheat			
Description		▪ Overheat in servo amplifier.			
Detailed display	Detailed Name	Cause	Checking method	Result	Action
45.1	Board temperature error	1) Ambient temperature is over 55°C.	Check if the ambient temperature is 55°C or less.	Ambient temperature is over 55°C.	Lower the ambient temperature.
				Ambient temperature is 55°C or less.	Check 2).
		2) Used beyond the specifications of close mounting.	Check the specifications of close mounting.	Used beyond the specifications.	Use within the range of specifications.
				Satisfying the specifications.	Check 3).
		3) The power was turned on and off continuously in overloaded status.	Check if the overloaded status occurred repeatedly.	Occurred repeatedly.	Check operation pattern.
				Not occurred.	Check 4).
		4) Heat sink and opening are clogged.	Check if the alarm occurs after cleaning the heat sink and the opening.	Alarm does not occur.	Clean periodically.
				Alarm occurs.	Check 5).
		5) Servo amplifier fault	Check if the alarm occurs after replacing the servo amplifier.	Alarm does not occur.	Use the normal servo amplifier.

Alarm No.: A.46		Name: Servo motor overheat			
Description		▪ Servo motor is overheated.			
Detailed display	Detailed Name	Cause	Checking method	Result	Action
46.1	Servo motor temperature error	1) Ambient temperature of the servo motor is over 40°C.	Check the ambient temperature of the servo motor.	Ambient temperature is over 40°C.	Lower the ambient temperature of servo motor.
				Ambient temperature is 40°C or less.	Check 2).
		2) Servo motor is overheated.	Check the effective load ratio.	The effective load ratio is too high.	Reduce the load or take heat dissipation measures.
				The effective load ratio is small	Check 3).
		3) Thermal sensor fault in the encoder.	Check the temperature of the servo motor.	The temperature of the servo motor is low.	Replace the servo motor.

8. TROUBLESHOOTING

Alarm No.: A.50		Name: Overload 1						
Description		▪ Load exceeded overload protection characteristic of servo amplifier.						
Detailed display	Detailed Name	Cause	Checking method	Result	Action			
50.1	Overload thermal 1 error during operation (Continuous operation protection)	1)	Electromagnetic brake operates.	Check if the electromagnetic brake does not operate during operation.	Operates.	Check the wiring.		
					Does not operate.	Check 2).		
		2)	Servo amplifier is used exceeding its continuous output current.	Check the effective load ratio.	Effective load ratio is too high.	Reduce load. Check operation pattern. Replace the servo motor to one that provides larger output.		
					Effective load ratio is small.	Check 3).		
		3)	Servo system is instable and resonating.	Check if resonance occurs.	Resonance occurs.	Execute the gain adjustment.		
					Resonance does not occur.	Check 4).		
		4)	After the overload alarm occurrence, the operation is restarted without the cooling time.	Check if the alarm was reset after 30 minutes had past since the alarm occurrence.	No.	Reset the alarm after the sufficient time.		
					Yes.	Check 5).		
		5)	Servo amplifier fault	Check if the alarm occurs after replacing the servo amplifier.	Alarm does not occur.	Replace the servo amplifier.		
		50.2	Overload thermal 2 error during operation (Short-time operation protection)	1)	The work collided against the structural part.	Check if the work collided against the structural part.	Collided.	Check the operation pattern.
							Did not collide.	Check 2).
				2)	Power cables breakage	Check the power cables.	An error is found.	Repair the power cables.
No error.	Check 3).							
3)	Incorrect connection with the servo motor			Check the wiring of U, V and W.	An error is found.	Wire correctly.		
					No error.	Check 4).		
4)	Electromagnetic brake operates.			Execute the checking methods mentioned in the alarm display "50.1".				
5)	Servo amplifier is used exceeding its continuous output current.							
6)	Servo system is instable and oscillating.							
7)	Servo amplifier fault							
8)	Encoder faulty.			Check if the alarm occurs after replacing the servo motor.	Alarm does not occur.	Replace the servo motor.		

8. TROUBLESHOOTING

Alarm No.: A.50		Name: Overload 1						
Description		▪ Load exceeded overload protection characteristic of servo amplifier.						
Detailed display	Detailed Name	Cause	Checking method	Result	Action			
50.4	Overload thermal 1 error at a stop (Continuous operation protection)	1)	Electromagnetic brake operates.	Check if the electromagnetic brake does not operate during stop.	Operates.	Check the wiring.		
					Does not operate.	Check 2).		
		2)	Servo amplifier is used exceeding its continuous output current.	Check the effective load ratio.	Effective load ratio is too high.	Reduce the load. Check operation pattern. Replace the servo motor to one that provides larger output.		
					Effective load ratio is small.	Check 3).		
		3)	Hunting at servo lock	Check if hunting occurs.	Hunting occurs.	Execute the gain adjustment.		
					Hunting does not occur.	Check 4).		
		4)	After the overload alarm occurs, the operation is restarted without the cooling time.	Check if the alarm was reset after 30 minutes had past since the alarm occurrence.	No.	Reset the alarm after the sufficient time.		
					Yes.	Check 5).		
		5)	Servo amplifier fault	Check if the alarm occurs after replacing the servo amplifier.	Alarm does not occur.	Replace the servo amplifier.		
		50.5	Overload thermal 2 error at a stop (Short-time operation protection)	1)	The load is large at a stop.	Check if the work collided against the structural part.	Collided.	Check the operation pattern.
							Did not collide.	Check 2).
				2)	Power cables breakage	Check the power cables.	An error is found.	Repair the power cables.
No error.	Check 3).							
3)	Incorrect connection with the servo motor			Check the wiring of U, V and W.	An error is found.	Wire correctly.		
					No error.	Check 4).		
4)	Electromagnetic brake operates.			Execute the checking methods mentioned in the alarm display "50.4".				
5)	Servo amplifier is used exceeding its continuous output current.							
6)	A hunting occurs at a stop.							
7)	Servo amplifier fault							
8)	Encoder faulty.			Check if the alarm occurs after replacing the servo motor.	Alarm does not occur.	Replace the servo motor.		

8. TROUBLESHOOTING

Alarm No.: A.51		Name: Overload 2			
Description		▪ Machine collision or the like caused continuous flow of the maximum output current for a few seconds.			
Detailed display	Detailed Name	Cause	Checking method	Result	Action
51.1	Overload thermal 3 error during operation	1) Power cables breakage	Check the power cables.	An error is found.	Repair the power cables.
				No error.	Check 2).
		2) Incorrect connection with the servo motor	Check the wiring of U, V and W.	An error is found.	Wire correctly.
				No error.	Check 3).
		3) Incorrect connection of the encoder cable	Check if the encoder cable is connected correctly.	An error is found.	Correct the connection.
				No error.	Check 4).
		4) The work collided against the structural part.	Check if the work collided against the structural part.	Collided.	Check the operation pattern.
				Did not collide.	Check 5).
		5) Torque is saturated.	Check the torque during the operation.	Torque is saturated.	Check the operation pattern.
				Torque is not saturated.	Check 6).
		6) Servo amplifier fault	Check if the alarm occurs after replacing the servo amplifier.	Alarm does not occur.	Replace the servo amplifier.
				Alarm occurs.	Check 7).
		7) Encoder faulty.	Check if the alarm occurs after replacing the servo motor.	Alarm does not occur.	Replace the servo motor.
		51.2	Overload thermal 3 error at a stop	1) Power cables breakage	Execute the checking methods mentioned in the alarm display "51.1".
2) Incorrect connection with the servo motor					
3) Incorrect connection of the encoder cable					
4) The work collided against the structural part.					
5) Torque is saturated.					
6) Servo amplifier fault					
7) Encoder faulty.					

8. TROUBLESHOOTING

Alarm No.: A.52		Name: Error excessive			
Description		▪ The droop pulse between the command position and the current position exceeds the alarm level.			
Detailed display	Detailed Name	Cause	Checking method	Result	Action
52.3	Droop pulses excessive	1) Servo motor power cables are not connected. (missing phase)	Check the wiring.	Not connected (missing phase).	Correct the wiring.
				No error.	Check 2).
		2) Incorrect connection with the servo motor	Check the wiring of U, V and W.	Incorrect connection.	Correct the wiring.
				Correct connection.	Check 3).
		3) Incorrect connection of the encoder cable	Check if the encoder cable is connected correctly.	Incorrect connection.	Correct the wiring.
				Correct connection.	Check 4).
		4) Torque limit value is small.	Check the torque limit value.	Torque limit value is small.	Increase the torque limit value.
				Normal range	Check 5).
		5) The work collided against the structural part.	Check if the work collided against the structural part.	Collided.	Check the operation pattern.
				Did not collide.	Check 6).
		6) Torque shortage	Check if the torque is saturated.	Saturated	Reduce load. Check operation pattern. Replace the servo motor to one that provides larger output.
				Not saturated	Check 7).
		7) Servo motor cannot be started due to torque shortage caused by power supply voltage drop.	Check the value of status display Pn (bus voltage).	The value is "1" (undervoltage) or "2" (low voltage).	Check the power supply voltage.
				The value is "4" (high voltage) or "5" (overvoltage).	Check 8).
		8) Acceleration/deceleration time constant is short.	Check if the alarm occurs after the deceleration time constant is increased.	Alarm does not occur.	Check operation pattern.
				Alarm occurs.	Check 9).
		9) Gain adjustment is not made well.	Check the load to motor inertia moment ratio.	Load to motor inertia moment ratio is normal.	Use the manual mode to make gain adjustment.
				Load to motor inertia moment ratio is not normal.	Check 10).
		10) Estimation of the load to motor inertia moment ratio is not estimated well.	Check if the alarm occurs after changing the load to motor inertia moment ratio manually.	Alarm does not occur.	Check the load to motor inertia moment ratio.
				Alarm occurs.	Check 11).
11) Position loop gain value is small.	Check if the alarm occurs after the position loop gain is changed.	Alarm does not occur.	Check the position loop gain.		
		Alarm occurs.	Check 12).		
12) Servo motor is rotated by external force.	Measure the actual position on the servo lock status.	The servo motor is rotated by an external force.	Check the machine.		
		Servo motor is not rotated by an external force.	Check 13).		
13) Encoder faulty	Check if the alarm occurs after replacing with the servo operating normally.	Alarm does not occur.	Replace the servo motor.		

8. TROUBLESHOOTING

Alarm No.: A.52		Name: Error excessive			
Description		▪ The droop pulse between the command position and current position exceeds the alarm level.			
Detailed display	Detailed Name	Cause	Checking method	Result	Action
52.4	Error excessive at torque limit value zero	1) Torque limit value is "0".	Check the torque limit value.	Torque limit value is "0".	Increase the torque limit value.

Alarm No.: A.61		Name: Operation alarm			
Description		▪ The point table is incorrect.			
Detailed display	Detailed Name	Cause	Checking method	Result	Action
61.1	Auxiliary function setting error	1) "1" or "3" is set to the auxiliary function of the last point table (No.7).	Check the auxiliary function value of the last point table.	"1" or "3" is set.	Check the setting.

Alarm No.: A.8E		Name: USB communication error				
Description		▪ USB communication error occurred between the servo amplifier and the communication device (e.g. personal computer).				
Detailed display	Detailed Name	Cause	Checking method	Result	Action	
8E.1	USB communication receive error	1)	Communication cable fault	Check if the alarm occurs after replacing the USB cable.	Alarm does not occur.	Replace the USB cable.
				Alarm occurs.	Check 2).	
		2)	Communication device (e.g. personal computer) setting error	Check the communication setting of the communication device.	Incorrect setting	Check the setting.
					Correct setting	Check 3).
		3)	Fault in the surrounding environment	Check the noise, etc.	An error is found.	Take the appropriate measures according to the cause.
					No error.	Check 4).
		4)	Servo amplifier fault	Check if the alarm occurs after replacing the servo amplifier.	Alarm does not occur.	Replace the servo amplifier.
		8E.2	USB communication checksum error	1)	Communication cable fault	Execute the checking methods mentioned in the alarm display "8E.1".
2)	Communication device (e.g. personal computer) setting error					
3)	Fault in the surrounding environment					
4)	Servo amplifier fault					
8E.3	USB communication character error	1)	Communication cable fault	Execute the checking methods mentioned in the alarm display "8E.1".		
		2)	Communication device (e.g. personal computer) setting error			
		3)	Fault in the surrounding environment			
		4)	Servo amplifier fault			

8. TROUBLESHOOTING

Alarm No.: A.8E		Name: USB communication error			
Description		▪ USB communication error occurred between the servo amplifier and the communication device (e.g. personal computer).			
Detailed display	Detailed Name	Cause		Checking method	Action
8E.4	USB communication command error	1)	Communication cable fault	Execute the checking methods mentioned in the alarm display "8E.1".	
		2)	Communication device (e.g. personal computer) setting error		
		3)	Fault in the surrounding environment		
		4)	Servo amplifier fault		
8E.5	USB communication data No. error	1)	Communication cable fault	Execute the checking methods mentioned in the alarm display "8E.1".	
		2)	Communication device (e.g. personal computer) setting error		
		3)	Fault in the surrounding environment		
		4)	Servo amplifier fault		

Alarm No.: 888 (Note)		Name: Watchdog			
Description		▪ CPU or part is faulty.			
Detailed display	Detailed Name	Cause		Checking method	Action
		1)	Fault of parts in the servo amplifier		Replace the servo amplifier.

Note. At power-on, "888" appears instantaneously, but it is not an error.

8. TROUBLESHOOTING

8.3 Remedies for warnings

POINT
<ul style="list-style-type: none"> ▪ When any of the following alarms has occurred, do not resume operation by switching power of the servo amplifier OFF/ON repeatedly. The servo amplifier and servo motor may become faulty. If the power of the servo amplifier is switched OFF/ON during the alarms, allow more than 30 minutes for cooling before resuming operation. <ul style="list-style-type: none"> ▪ Excessive regenerative warning (E0.1) ▪ Servo amplifier overheat warning (91.1) ▪ Overload warning 1 (E1. □)

When the warning "The servo motor stops." described in the following table occurs, the servo-off occurs and the servo motor stops. If any other warning occurs, operation can be continued but an alarm may take place or proper operation may not be performed.

Remove the cause of warning according to this section. Use MR Configurator to refer to a factor of warning occurrence.

Alarm No.: A.90		Name: Home positioning incomplete warning		The servo motor stops.	
Warning contents		▪ Home position return is not performed correctly.			
Detailed display	Detailed Name	Cause	Checking method	Result	Action
90.1	Home position return incompleton	1) Positioning operation was performed without home position return.	Check if home position return was performed.	Home position return was not performed.	Perform home position return.
90.2	Home position return abnormal completion	1) Home position return speed could not be decreased to the creep speed.	Check the home position return speed, the creep speed and the travel distance after proximity dog.	The set value is incorrect.	Set correctly and perform home position return.

Alarm No.: A.91		Name: Servo amplifier overheat error		The servo motor does not stop.	
Warning contents		▪ The temperature inside of the servo amplifier exceeds the warning level.			
Detailed display	Detailed Name	Cause	Checking method	Result	Action
91.1	Servo amplifier inside overheat warning	1) The temperature in the servo amplifier is high.	Check the ambient temperature of the servo amplifier.	Ambient temperature is high. (over 55°C)	Lower the ambient temperature.
				Ambient temperature is low.	Check 2).
		2) Used beyond the specifications of close mounting.	Check the specifications of close mounting.	Used beyond the specifications.	Use within the range of specification.

Alarm No.: A.96		Name: Home position setting error		The servo motor stops.	
Warning contents		▪ Incorrectly finished after home position return operation.			
Detailed display	Detailed Name	Cause	Checking method	Result	Action
96.1	In-position not reached	1) Droop pulses remaining are greater than the in-position range setting.	Check the number of droop pulses after home position return.	In-position range or more	Remove the cause of droop pulse occurrence.

8. TROUBLESHOOTING

Alarm No.: A.96		Name: Home position setting error		The servo motor stops.		
Description		▪ Incorrectly finished after home position return operation.				
Detailed display	Detailed Name	Cause	Checking method	Result	Action	
96.2	Speed command not converged	1)	The speed command does not become "0" after home position return.	Check the speed command value after home position return.	Speed Command outputting Speed Command not outputting	Set the speed command to "0". Check 2).
		2)	The creep speed is too fast.	Check the creep speed.	The creep speed is too fast.	Reduce the creep speed.

Alarm No.: A.97		Name: Program operation disabled		The servo motor does not stop.		
Warning contents		▪ The program operation was performed during program operation disabled status.				
Detailed display	Detailed Name	Cause	Checking method	Result	Action	
97.1	Program operation disabled	1)	The program was started without switching OFF/ON the power of the servo amplifier.	Check if the power of the servo amplifier is switched OFF/ON.	The power of the servo amplifier is not switched OFF/ON.	Switch OFF/ON the power of the servo amplifier.

Alarm No.: A.98		Name: Software limit warning		The servo motor stops.		
Description		▪ The current position reached the software stroke limit (set in the parameter No. PE16 to PE19).				
Detailed display	Detailed Name	Cause	Checking method	Result	Action	
98.1	Reached the software limit at the forward rotation	1)	Software limit was set within the actual movable range.	Check the set value of the parameter.	Within the movable range Outside the movable range	Set the parameter correctly. Check 2).
		2)	Point table/program with the position data in excess of the software limit at the forward rotation was executed.	1. Check the set value of the point table/program. 2. Check the operation method.	Within the movable range In manual operation	Create the point table/program correctly. Check 3).
		3)	Software limit at the forward rotation side was reached during JOG operation or manual pulse generator operation.	Check if the software limit at the forward rotation side is reached.	Software limit at the forward rotation side is reached.	Perform operation within software limit range.
98.2	Reached the software limit at the reverse rotation side	1)	Software limit was set within the actual movable range.	Check the set value of the parameter.	Within the movable range Outside the movable range	Set the parameter correctly. Check 2).
		2)	Point table/program with the position data in excess of the software limit at the reverse rotation was executed.	1. Check the set value of the point table/program. 2. Check the operation method.	Within the movable range In manual operation	Create the point table/program correctly. Check 3).
		3)	Software limit at the reverse rotation side was reached during JOG operation or manual pulse generator operation.	Check if the software limit at the reverse rotation side is reached.	Software limit at the reverse rotation side is reached.	Perform operation within software limit range.

8. TROUBLESHOOTING

Alarm No.: A.99		Name: Stroke limit warning		The servo motor stops.	
Warning contents		▪ Reached to the stroke limit of the moving direction (signal off).			
Detailed display	Detailed Name	Cause	Checking method	Result	Action
99.1	Forward rotation stroke end: OFF	1) The forward rotation limit switch became valid.	Check if the forward rotation stroke end (LSP) is ON or OFF in the external I/O signal display.	The forward rotation stroke end (LSP) is OFF.	Reexamine the operation pattern to turn ON the forward rotation stroke end (LSP).
99.2	Reverse rotation stroke end: OFF	2) The reverse rotation limit switch became valid.	Check if the reverse rotation stroke end (LSN) is ON or OFF in the external I/O signal display.	The reverse rotation stroke end (LSN) is OFF.	Reexamine the operation pattern to turn ON the reverse rotation stroke end (LSN).

Alarm No.: A.E0		Name: Excessive regenerative warning		The servo motor does not stop.	
Warning contents		▪ There is a possibility that regenerative power may exceed the permissible regenerative power of the built-in regenerative resistor or the regenerative option.			
Detailed display	Detailed Name	Cause	Checking method	Result	Action
E0.1	Excessive regenerative warning	1) Regenerative power exceeded 85% of the permissible regenerative power of the built-in regenerative resistor or the regenerative option.	Call the status display or MR Configurator and check the regenerative load ratio.	85% or more.	Reduce the frequency of positioning. Increase the deceleration time constant. Reduce the load. Use the regenerative option, if it is not used.

Alarm No.: A.E1		Name: Overload warning 1		The servo motor does not stop.	
Warning contents		▪ The overload alarm (50. □, 51. □) may occur.			
Detailed display	Detailed Name	Cause	Checking method	Result	Action
E1.1	The overload thermal 1 warning while motor rotating	1) Load exceeded 85% of the alarm level of the overload alarm (50.1).	Execute the checking methods mentioned in the alarm display "50.1".		
E1.2	The overload thermal 2 warning while motor rotating	1) Load exceeded 85% of the alarm level of the overload alarm (50.2).	Execute the checking methods mentioned in the alarm display "50.2".		
E1.3	The overload thermal 3 warning while motor rotating	1) Load increased to 85% or more against the alarm level of the overload alarm (51.1).	Execute the checking methods mentioned in the alarm display "51.1".		
E1.5	The overload thermal 1 warning while motor not rotating	1) Load exceeded 85% of the alarm level of the overload alarm (50.4).	Execute the checking methods mentioned in the alarm display "50.4".		

8. TROUBLESHOOTING

Alarm No.: A.E1		Name: Overload warning 1		The servo motor does not stop.	
Warning contents		▪ The overload alarm (50. □, 51. □) may occur.			
Detailed display	Detailed Name	Cause	Checking method	Result	Action
E1.6	The overload thermal warning 2 while motor not rotating	1) Load exceeded 85% of the alarm level of the overload alarm (50.5).	Execute the checking methods mentioned in the alarm display "50.5".		
E1.7	The overload thermal warning 3 while motor not rotating	1) Load exceeded 85% of the alarm level of the overload alarm (51.2).	Execute the checking methods mentioned in the alarm display "51.1".		

Alarm No.: A.E6		Name: Servo forced stop warning		The servo motor stops.	
Warning contents		▪ The forced stop signal is turned OFF.			
Detailed display	Detailed Name	Cause	Checking method	Result	Action
E6.1	Servo forced stop warning	1) Forced stop (EM1) is turned OFF.	Check the forced stop (EM1).	OFF	Ensure safety and turn ON the forced stop (EM1).
				ON	Check 2).
		2) The external 24VDC power supply is not input.	Check if the external 24VDC power supply is input.	Not input.	Input 24VDC.
	Input.	Check 3).			
		3) Servo amplifier fault	Check if the alarm occurs after replacing the servo amplifier.	Alarm does not occur.	Replace the servo amplifier.

8. TROUBLESHOOTING

Alarm No.: A.E9		Name: Main circuit off warning		The servo motor stops.		
Warning contents		<ul style="list-style-type: none"> ▪ Servo-on (SON) was switched on when the main circuit power is off. ▪ The bus voltage decreased while the servo motor speed operates at 50r/min or slower. 				
Detailed display	Detailed Name	Cause	Checking method	Result	Action	
E9.1	Servo-on (SON) ON when the main circuit is OFF.	1)	Main circuit power supply is off.	Check if the main circuit power supply is input.	Not input. Input.	Switch on the main circuit power. Check 2).
		2)	Main circuit power supply connector is disconnected.	Check the main circuit power supply connector.	The connector is disconnected. No problem.	Connect properly. Check 3).
		3)	Main circuit power supply voltage is low.	Check if the main circuit power supply voltage is the following or less. MR-JN-□A:140VAC MR-JN-□A1:70VAC	MR-JN-□A:140VAC or less MR-JN-□A1:70VAC or less	Raise the main circuit power supply voltage.
					MR-JN-□A:Above 140VAC MR-JN-□A1:Above 70VAC	Check 4).
		4)	Servo amplifier for 1-phase 200VAC input is used for 100VAC power supply circuit.	Check the model of servo amplifier.	The model of servo amplifier is "MR-JN-□A".	Replace the servo amplifier whose model is "MR-JN-□A1".
					The model of servo amplifier is "MR-JN-□A1".	Check 5).
5)	Faulty servo amplifier for 1-phase 100VAC input is used.	Check if the charge lamp is turned on.	The charge lamp is not turned on.	Replace the servo amplifier.		
6)	Bus voltage dropped.	Check the value of status display Pn (bus voltage).	The value of the status display Pn (bus voltage) is "1" (overvoltage) or "2" (low voltage).	Revise the wiring. Check the power supply capacity.		
E9.2	Bus voltage drop at low-speed rotation	1)	When the set value of parameter No. PC29 (function selection C-5) is "□ 1 □", the bus voltage decreased while the servo motor operates at 50r/min or slower.	Check the value of status display Pn (bus voltage).	The value is "1" (undervoltage). Check the power supply capacity. Increase the acceleration time constant.	

8. TROUBLESHOOTING

Alarm No.: A.E9		Name: Main circuit off warning		The servo motor stops.	
Warning contents		<ul style="list-style-type: none"> ▪ Servo-on (SON) was switched on when the main circuit power is off. ▪ The bus voltage decreased while the servo motor speed operates at 50r/min or slower. 			
Detailed display	Detailed Name	Cause	Checking method	Result	Action
E9.3	Main circuit power supply failure	1) When the set value of parameter No. PC29 (function selection C-5) is "□ 1 □", the main circuit power supply turned OFF while the servo motor operates at 50r/min or slower.	Check if the main circuit power supply is input.	Not input.	Switch on the main circuit power.
				Input.	Check 2).
		2) When the set value of parameter No. PC29 (function selection C-5) is "□ 1 □", the connector of the main circuit power supply came off when the servo motor operates at 50r/min or slower.	Check the main circuit power supply connector.	The connector is disconnected.	Connect properly.
	No problem.	Check 3).			
		3) When the set value of parameter No. PC29 (function selection C-5) is "□ 1 □", the instantaneous power failure occurred while the servo motor operates at 50r/min or slower.	Check the main circuit power.		

Alarm No.: A.EC		Name: Overload warning 2		The servo motor does not stop.	
Warning contents		<ul style="list-style-type: none"> ▪ Operation, in which a current exceeding the rating flowed intensively in any of the U, V and W phases of the servo motor, was repeated. 			
Detailed display	Detailed Name	Cause	Checking method	Result	Action
EC.1	Overload warning 2	1) Current flowed intensively in specific phases of the servo motor during a stop. Also, this situation was continued.	Check if the alarm occurs after changing the stop position.	Alarm does not occur.	Reduce the frequency of positioning.
				Alarm occurs.	Check 2).
		2) The load is large, or the capacity is insufficient.	Measure the effective load ratio during a stop.	Effective load ratio is too high.	Reduce the load. Replace the servo amplifier and servo motor with the ones with larger capacity.

Alarm No.: A.ED		Name: Output watt excess warning		The servo motor does not stop.	
Warning contents		<ul style="list-style-type: none"> ▪ The status, in which the output wattage (speed × torque) of the servo motor exceeded the rated output, continued steadily. 			
Detailed display	Detailed Name	Cause	Checking method	Result	Action
ED.1	Output wattage over	1) Output wattage of the servo motor (speed × torque) exceeded 120% of the rated output.	Call the status display or MR Configurator and check the servo motor speed and torque.	The output wattage is 120% or more of the rate.	Reduce the servo motor speed. Reduce the load.

8. TROUBLESHOOTING

Alarm No.: A.F0		Name: Tough drive warning		The servo motor does not stop.	
Warning contents		▪ Switched to "during tough drive" status.			
Detailed display	Detailed Name	Cause	Checking method	Result	Action
F0.1	Instantaneous power failure tough drive warning	1) An instantaneous power failure in the main circuit power supply was detected.	Check the main circuit power supply.		
F0.2	Overload tough drive warning	1) Effective load ratio exceeded 90% the alarm level of the overload alarm.	Measure the effective load ratio in the continuous operation.	The effective load is over the overload warning level.	Reduce the load.
F0.3	Vibration tough drive warning	1) The reconfiguration of machine resonance suppression filter 1 or machine resonance suppression filter 2 occurred due to the machine resonance.	Check the alarm history.	Vibration tough drive warning (F0.3) occurs consecutively.	Adjust the servo gain by the auto tuning 1 or the one-touch tuning. Lower the response.

9. OUTLINE DRAWINGS

9. OUTLINE DRAWINGS

9.1 Servo amplifier

(1) MR-JN-10A • MR-JN-20A

MR-JN-10A1 MR-JN-20A1

[Unit: mm]

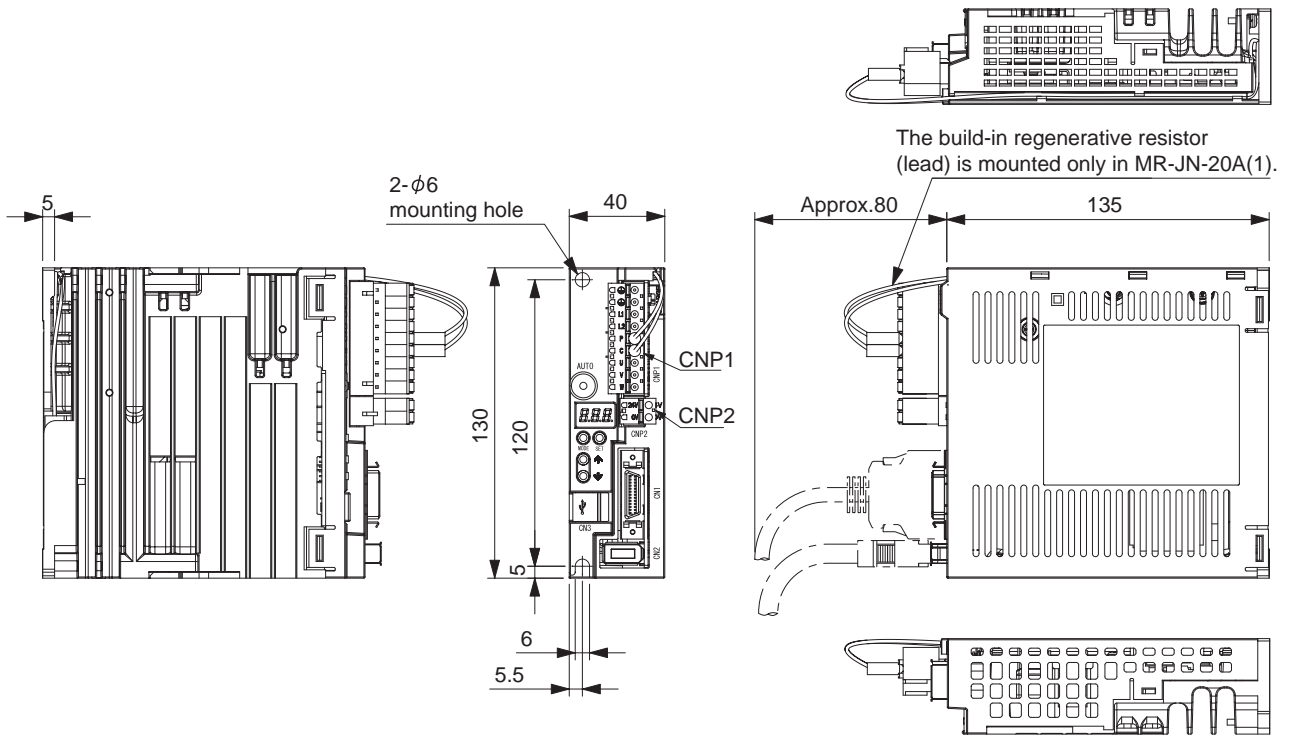

Mass: 0.6[kg] (1.32[lb])

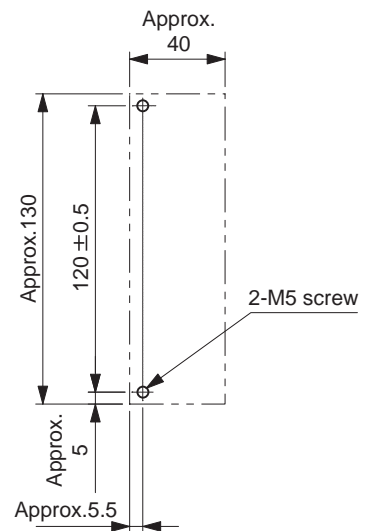
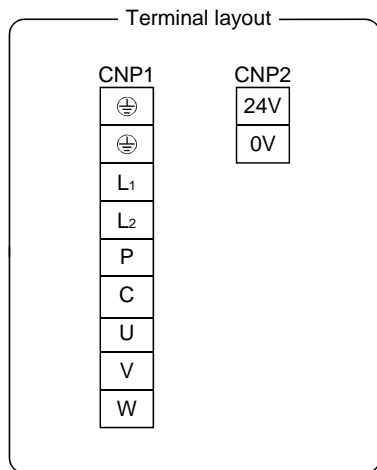

Mounting hole process drawing

Mounting screw

Screw size: M5

Tightening torque: 3.24[N • m] (28.7[lb • in])

9. OUTLINE DRAWINGS

(2) MR-JN-40A

[Unit: mm]

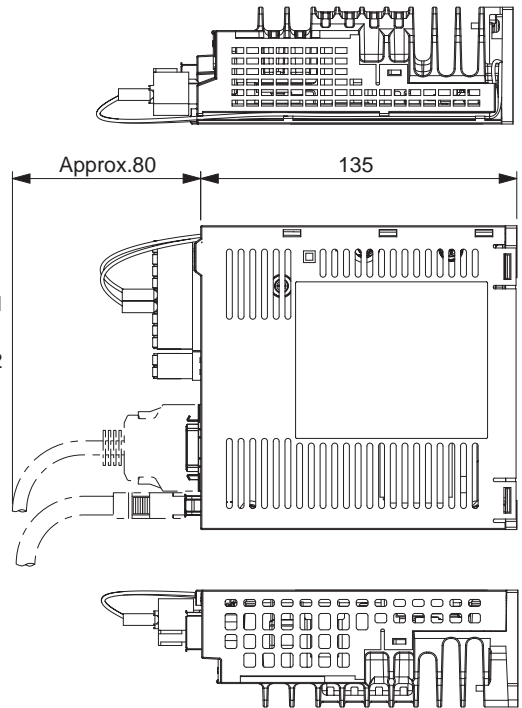
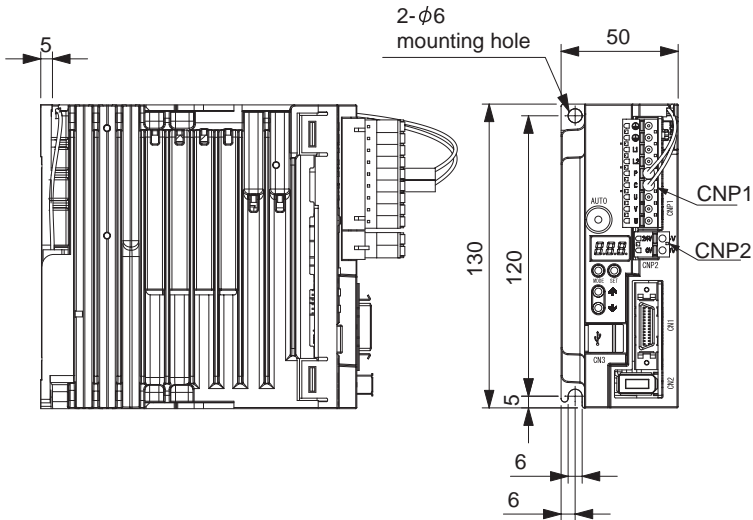

Mass: 0.7[kg] (1.54[lb])

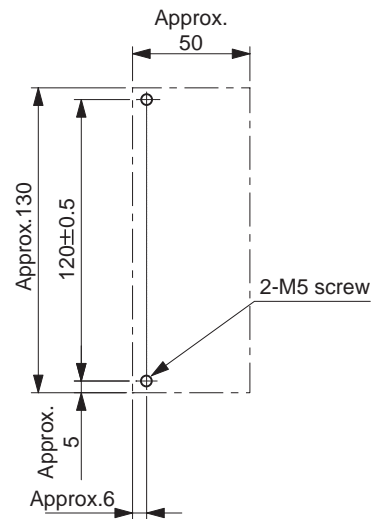
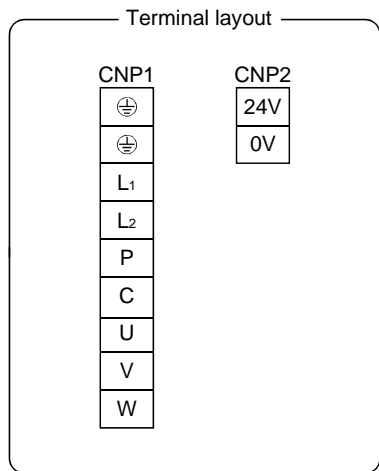

Mounting hole process drawing

Mounting screw

Screw size: M5

Tightening torque: 3.24[N · m] (28.7[lb · in])

9. OUTLINE DRAWINGS

9.2 Connector

(1) Miniature delta ribbon (MDR) system (3M)

(a) One-touch lock type

[Unit: mm]

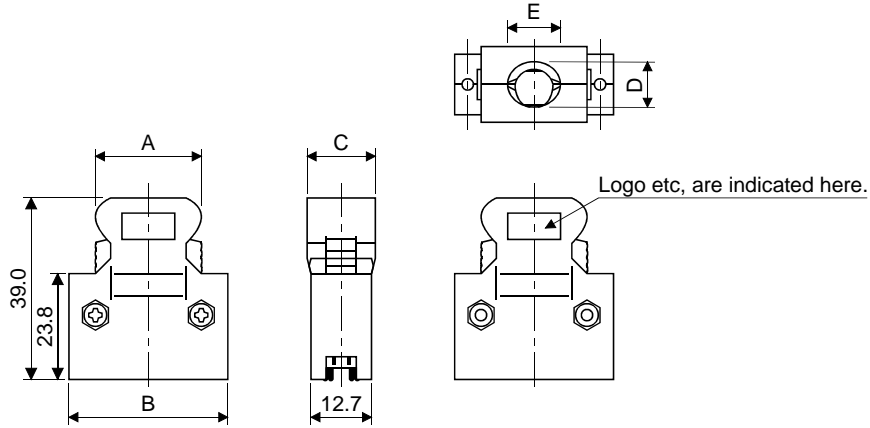

Connector	Shell kit	Each type of dimension				
		A	B	C	D	E
10126-3000PE	10326-52F0-008	25.8	37.2	14.0	10.0	12.0

(b) Jack screw M2.6 type

This is not available as option.

[Unit: mm]

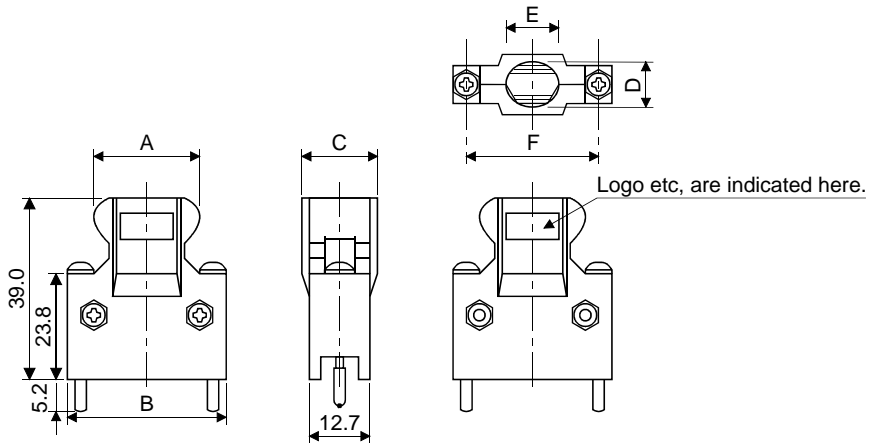

Connector	Shell kit	Each type of dimension					
		A	B	C	D	E	F
10126-3000PE	10326-52A0-008	25.8	37.2	14.0	10.0	12.0	27.4

9. OUTLINE DRAWINGS

(2) SCR connector system (3M)

Receptacle: 36210-0100PL

Shell kit : 36310-3200-008

[Unit: mm]

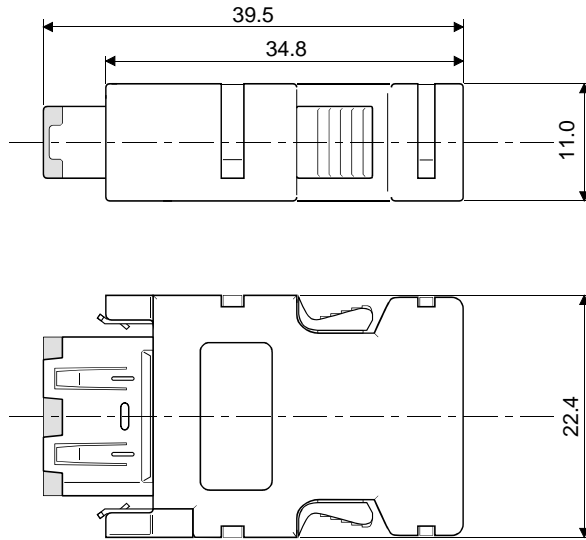

10. CHARACTERISTICS

10. CHARACTERISTICS

10.1 Overload protection characteristics

An electronic thermal relay is built in the servo amplifier to protect the servo motor, servo amplifier and servo motor power lines from overloads.

Overload 1 alarm (50.□) occurs if overload operation that exceeds the electronic thermal relay protection curve shown in Figs 10.1. is performed. Overload 2 alarm (51.□) occurs if the maximum current flows continuously for several seconds due to machine collision, etc. Keep the load ratio within the area in the left side of the solid line or the dotted line.

It is recommended to use the machine which generates unbalanced torque, e.g. a vertical lift application, so that the unbalanced torque is not more than 70% of the rated torque. When closely mounting the servo amplifiers, operate them at the ambient temperature of 0°C to 45°C (32°F to 113°F) or at 75% or smaller effective load ratio.

The servo motor overload protective function is built in MR-JN series servo amplifiers. (115% of the servo amplifier rated current is set as standard (full load current).)

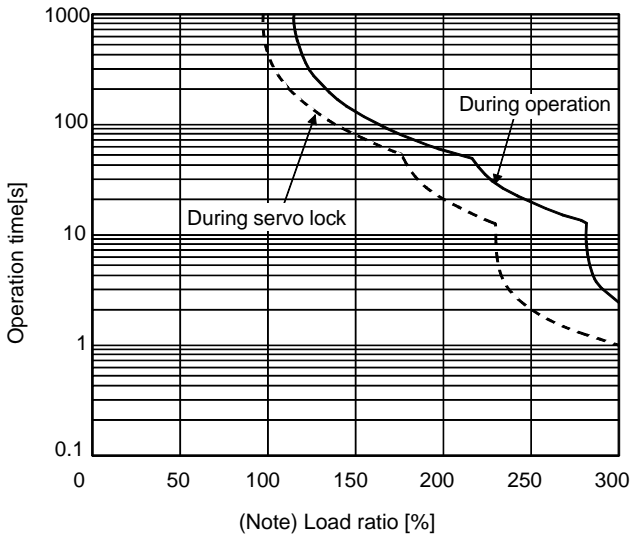

MR-JN-10A (1)

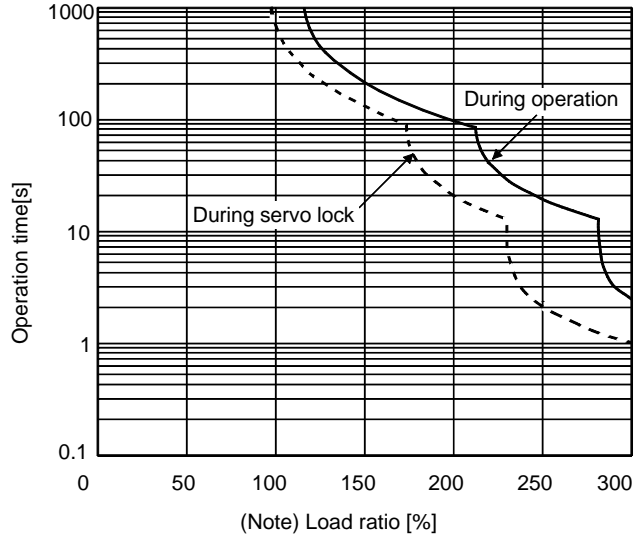

MR-JN-20A (1), MR-JN-40A

Note. If operation that generates torque equal to or higher than the rating is performed with an abnormally high frequency under servo motor stop status (servo lock status) or in low-speed operation at 30r/min or less, the servo amplifier may malfunction even when the servo system is used within the electric thermal protection area.

Fig 10.1 Electronic thermal relay protection characteristics

10. CHARACTERISTICS

10.2 Power supply capacity and generated loss

(1) Amount of heat generated by the servo amplifier

Table 10.1 indicates servo amplifiers' power supply capacities and losses generated under rated load. For thermal design of an enclosure, use the values in Table 10.1 in consideration for the worst operating conditions. The actual amount of generated heat will be intermediate between values at rated torque and servo off according to the duty used during operation. When the servo motor is operated at less than the maximum speed, the power supply capacity will be smaller than the value in the table, but the servo amplifier's generated heat will not change.

Table 10.1 Power supply capacity and generated heat per servo amplifier at rated output

Servo amplifier	Servo motor	(Note 1) Power supply capacity[kVA]	(Note 2) Servo amplifier-generated heat[W]		Area required for heat dissipation [m ²]
			At rated torque	With servo off	
MR-JN-10A (1)	HF-KN053 • 13	0.3	20	10	0.5
	HF-KP053G1/G5/G7				
	HF-KP13G1/G5/G7				
MR-JN-20A (1)	HF-KN23	0.5	20	10	0.5
	HF-KP23G1/G5/G7				
MR-JN-40A	HF-KN43	0.9	30	10	0.5
	HF-KN43G1/G5/G7				

Note 1. Note that the power supply capacity will vary according to the power supply impedance. This value is applicable when the power factor improving reactor is not used.

2. Heat generated during regeneration is not included in the servo amplifier-generated heat. To calculate heat generated by the regenerative option, refer to section 11.2.

(2) Heat dissipation area for enclosed servo amplifier

The enclosed control box (hereafter called the control box) which will contain the servo amplifier should be designed to ensure that its temperature rise is within +10°C at the ambient temperature of 40°C. (With a 5°C (41°F) safety margin, the system should operate within a maximum 55°C (131°F) limit.) The necessary enclosure heat dissipation area can be calculated by Equation 10.1.

$$A = \frac{P}{K \cdot \Delta T} \dots\dots\dots (10.1)$$

A : Heat dissipation area [m²]

P : Loss generated in the control box [W]

ΔT : Difference between internal and ambient temperatures [°C]

K : Heat dissipation coefficient [5 to 6]

When calculating the heat dissipation area with Equation 10.1, assume that P is the sum of all losses generated in the enclosure. Refer to Table 10.1 for heat generated by the servo amplifier. "A" indicates the effective area for heat dissipation, but if the enclosure is directly installed on an insulated wall, that extra amount must be added to the enclosure's surface area. The required heat dissipation area will vary with the conditions in the enclosure. Therefore, arrangement of the equipment in the enclosure and the use of a cooling fan should be considered. Table 10.1 lists the enclosure dissipation area for each servo amplifier when the servo amplifier is operated at the ambient temperature of 40°C (104°F) under rated load.

10. CHARACTERISTICS

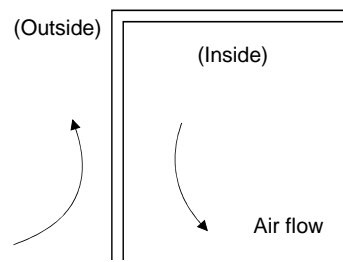

Fig. 10.2 Temperature distribution in enclosure

When air flows along the outer wall of the enclosure, effective heat exchange will be possible, because the temperature slope inside and outside the enclosure will be steeper.

10. CHARACTERISTICS

10.3 Dynamic brake characteristics

POINT
<ul style="list-style-type: none"> ▪ The dynamic brake is operated when an alarm occurs, a servo forced stop warning occurs, or the power turns off. The dynamic brake is a function for emergency stops. Do not use this function for normal stops. ▪ The criteria for the number of times the dynamic brake is used is 1000 times, in the condition that the machine with recommended load to motor inertia moment ratio or less, stops from the rated speed in a frequency of once per 10 minutes. ▪ When using the forced stop (EM1) frequently for other than emergencies, be sure to turn off the forced stop (EM1) after the servo motor stops.

10.3.1 Dynamic brake operation

(1) Calculation of coasting distance

Fig. 10.3 shows the pattern in which the servo motor comes to a stop when the dynamic brake is operated. Use Equation 10.2 to calculate an approximate coasting distance to a stop. The dynamic brake time constant τ varies with the servo motor and machine operation speeds. (Refer to paragraph (2) of this section.)

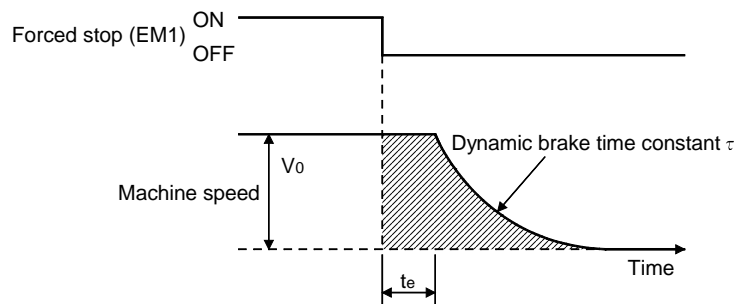

Fig. 10.3 Dynamic brake operation diagram

$$L_{\max} = \frac{V_0}{60} \cdot \left\{ t_e + \tau \left(1 + \frac{J_L}{J_M} \right) \right\} \dots\dots\dots (10.2)$$

- L_{\max} : Maximum coasting distance [mm][in]
- V_0 : Machine rapid feed rate..... [mm/min][in/min]
- J_M : Servo motor inertial moment [kg · cm²][oz · cm²]
- J_L : Load inertia moment converted into equivalent value on servo motor shaft
..... [kg · cm²][oz · cm²]
- τ : Dynamic brake time constant [s]
- t_e : Delay time of control section [s]
There is internal relay delay of about 10ms.

10. CHARACTERISTICS

(2) Dynamic brake time constant

The following shows necessary dynamic brake time constant τ for the equations (10.2).

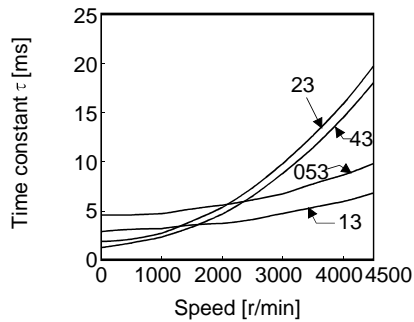

HF-KN series

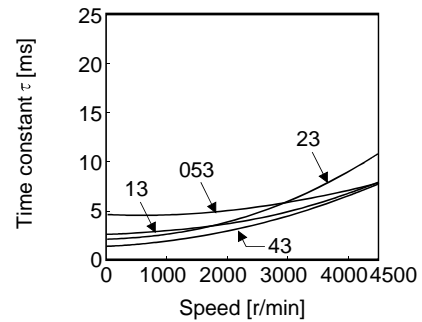

HF-KP series

10.3.2 The dynamic brake at the load inertia moment

Use the dynamic brake under the load to motor inertia moment ratio indicated in the following table. If the load to motor inertia moment is higher than this value, the dynamic brake may burn. If there is a possibility that the load to motor inertia moment may exceed the value, contact your local sales office.

The values of the load to motor inertia moment ratio in the table are the values at the maximum rotation speed of the servo motor.

Servo amplifier	Servo motor	
	HF-KN□	HF-KP□G1/G5/G7
MR-JN-10A (1)	30	
MR-JN-20A (1)	30	
MR-JN-40A	30	

10. CHARACTERISTICS

10.4 Cable flexing life

The flexing life of the cables is shown below. This graph calculated values. Since they are not guaranteed values, provide a little allowance for these values.

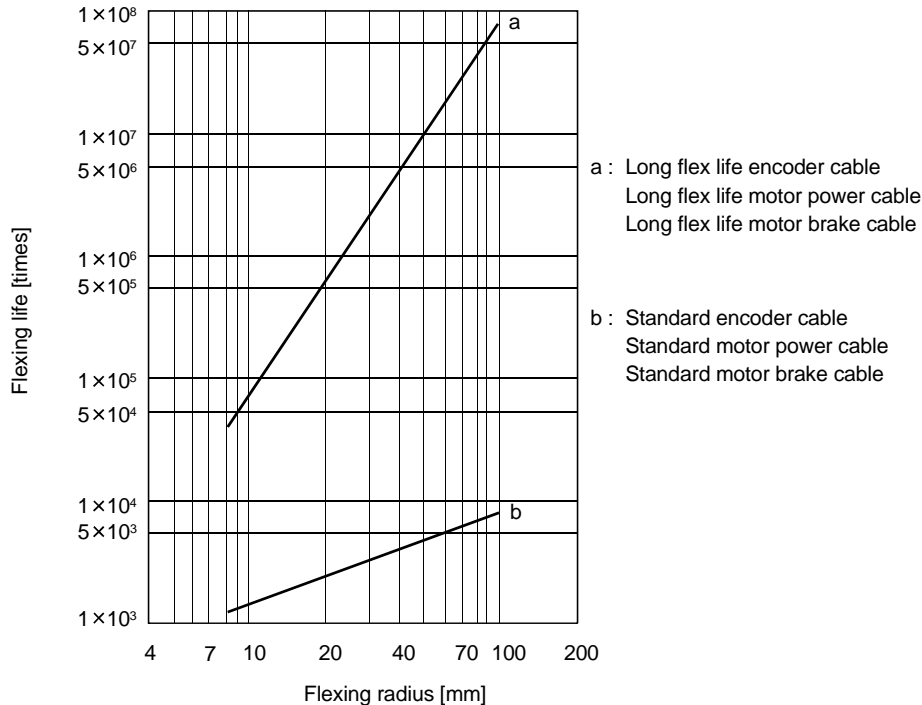

10.5 Inrush currents at power-on of main circuit and control circuit

The following table indicates the inrush currents (reference data) that flow when the maximum permissible voltage (main circuit power supply: 253VAC, control circuit power supply: 26.4VDC) is applied at the power supply capacity of 2500kVA and the wiring length of 1m.

Servo amplifier	Inrush currents (A _{0-P})	
	Main circuit power supply (L ₁ • L ₂)	Control circuit power supply (+24V • 0V)
MR-JN-10A1/20A1	55A (Attenuated to approx. 15A in 10ms)	25A (Attenuated to approx. 0A in 4 to 6ms)
MR-JN-10A to 40A	130A (Attenuated to approx. 5A in 5ms)	25A (Attenuated to approx. 0A in 4 to 6ms)

Since large inrush currents flow in the main circuit power supply, always use no-fuse breakers and magnetic contactors. (Refer to section 11.6.)

When a circuit protector is used for the main circuit power supply, it is recommended to use the inertia delay type that will not be tripped by an inrush current.

Always use a circuit protector for the control circuit power supply. (Refer to section 11.11.)

11. OPTIONS AND AUXILIARY EQUIPMENT

11. OPTIONS AND AUXILIARY EQUIPMENT

 **WARNING**

- Before connecting options and peripheral equipment, turn off the power and wait for 15 minutes or more until the charge lamp turns off. Otherwise, an electric shock may occur. In addition, always confirm from the front of the servo amplifier whether the charge lamp is off or not.

 **CAUTION**

- Use the specified auxiliary equipment and options. Unspecified ones may lead to a fault or fire.

11.1 Cable/connector sets

POINT

- The IP rating indicated for cables and connectors is for a cable or connector alone. When the cables and connectors are used to connect the servo amplifier and servo motor, and if the IP rating of the servo amplifier and servo motor are lower than that of the cable and connector, specifications of the servo amplifier and servo motor apply.



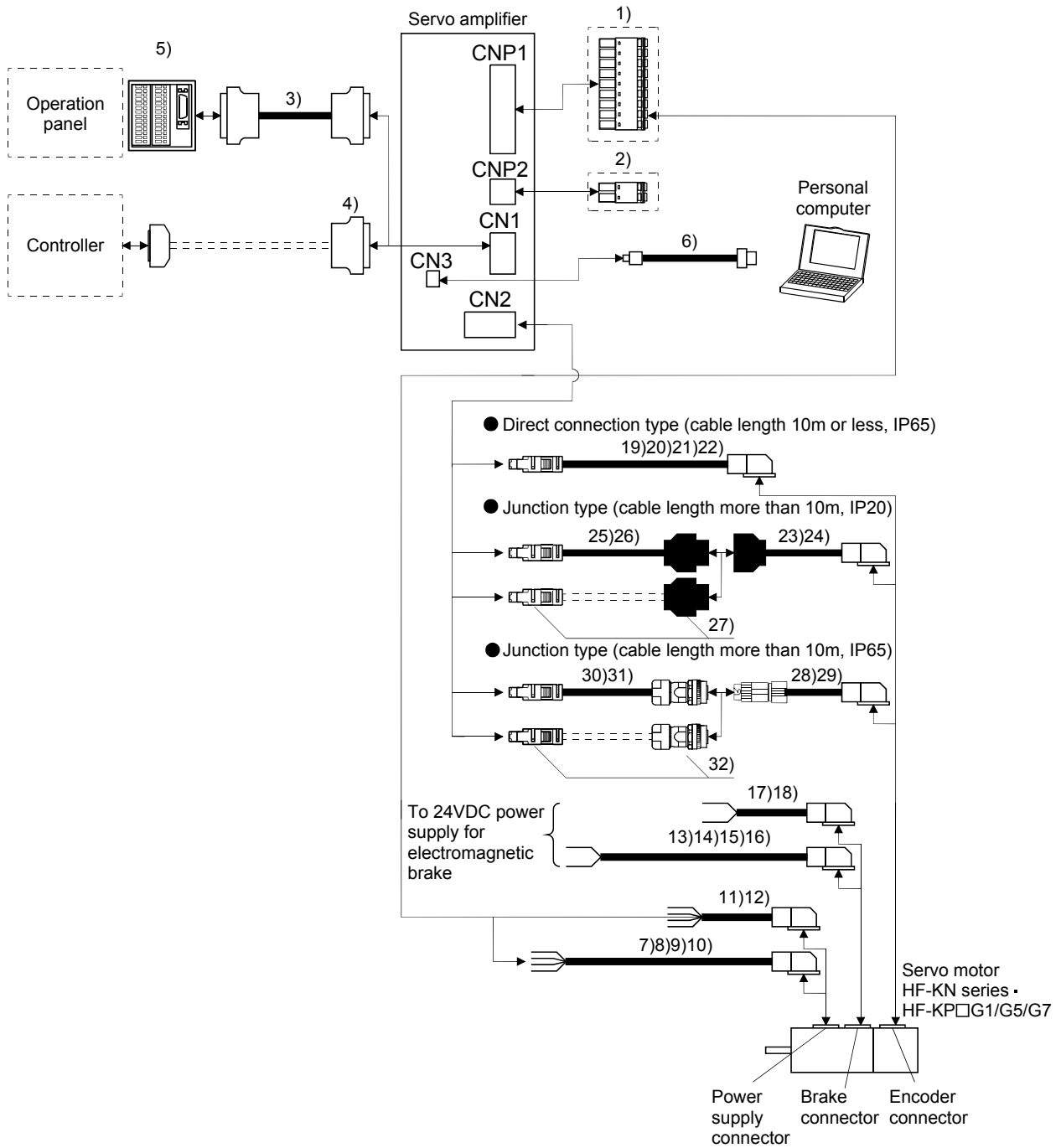

As the cables and connectors used with this servo, purchase the options indicated in this section.

11. OPTIONS AND AUXILIARY EQUIPMENT

11.1.1 Combinations of cable/connector sets



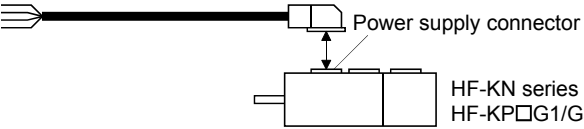
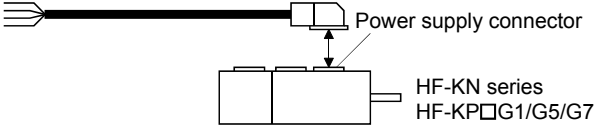

11. OPTIONS AND AUXILIARY EQUIPMENT

No.	Product	Model	Description		Application
1)	Servo amplifier main circuit power supply connector		 CNP1 Connector: FKC 2,5/9-ST-5,08 (Phoenix Contact) <Applicable cable example> Wire size: 0.2 to 2.5mm ² (AWG24 to AWG12) Cable finish OD: to ϕ 4mm		Supplied with servo amplifiers.
2)	Servo amplifier control circuit power supply connector		 CNP2 Connector: FKCT 2,5/ 2-ST-5,08 (Phoenix Contact) <Applicable cable example> Wire size: 0.2 to 2.5mm ² (AWG24 to AWG12) Cable finish OD: to ϕ 4mm		Supplied with servo amplifiers.
3)	Junction terminal block cable	MR-TBNATBL □ M Cable length: 0.5 · 1m (Refer to section 11.3)	For junction terminal block connector Connector: 10126-6000EL Shell kit: 10326-3210-000 (3M or equivalent)	For servo amplifier connector Connector: 10126-6000EL Shell kit: 10326-3210-000 (3M or equivalent)	For junction terminal block connection
					
4)	CN1 connector set	MR-J2CMP2	Connector: 10126-3000PE Shell kit: 10326-52F0-008 (3M or equivalent)		
5)	Junction terminal block	MR-TB26A	Refer to section 11.3.		
6)	USB cable	MR-J3USBCBL3M Cable length: 3m	For CN3 connector minB connector (5 pins)	For personal computer connector A connector	For connection with PC-AT compatible personal computer
					
7)	Motor power supply cable	MR-PWS1CBL □ M-A1-L Cable length: 2 · 5 · 10m	 Power supply connector HF-KN series HF-KP□G1/G5/G7		IP65 Load side lead
8)	Motor power supply cable	MR-PWS1CBL □ M-A1-H Cable length: 2 · 5 · 10m	Refer to section 11.1.3 for details.		IP65 Load side lead Long flex life
9)	Motor power supply cable	MR-PWS1CBL □ M-A2-L Cable length: 2 · 5 · 10m	 Power supply connector HF-KN series HF-KP□G1/G5/G7		IP65 Opposite-to-load side lead
10)	Motor power supply cable	MR-PWS1CBL □ M-A2-H Cable length: 2 · 5 · 10m	Refer to section 11.1.3 for details.		IP65 Opposite-to-load side lead Long flex life

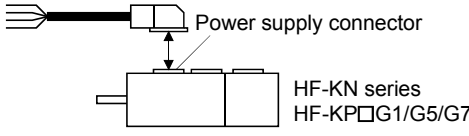
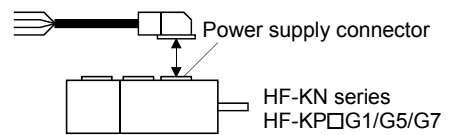
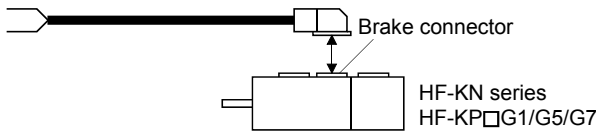
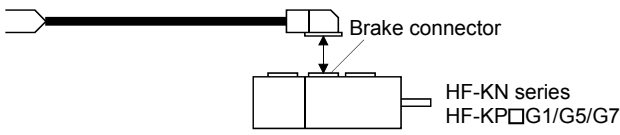
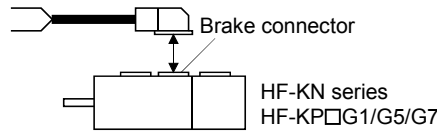
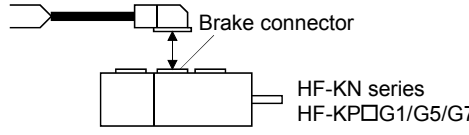
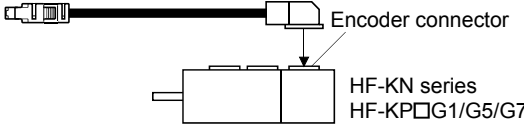

11. OPTIONS AND AUXILIARY EQUIPMENT

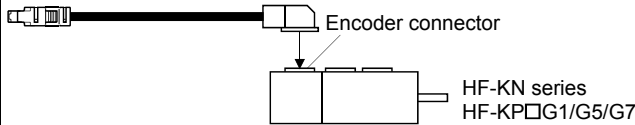
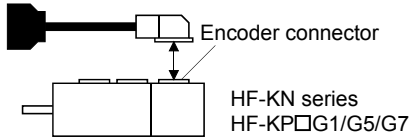
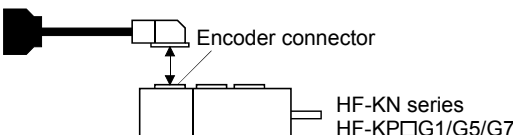
No.	Product	Model	Description	Application
11)	Motor power supply cable	MR-PWS2CBL03M-A1-L Cable length: 0.3m	 <p>Power supply connector</p> <p>HF-KN series HF-KP□G1/G5/G7</p> <p>Refer to section 11.1.3 for details.</p>	IP55 Load side lead
12)	Motor power supply cable	MR-PWS2CBL03M-A2-L Cable length: 0.3m	 <p>Power supply connector</p> <p>HF-KN series HF-KP□G1/G5/G7</p> <p>Refer to section 11.1.3 for details.</p>	IP55 Opposite-to-load side lead
13)	Motor brake cable	MR-BKS1CBL □ M-A1-L Cable length: 2 * 5 * 10m	 <p>Brake connector</p> <p>HF-KN series HF-KP□G1/G5/G7</p> <p>Refer to section 11.1.4 for details.</p>	IP65 Load side lead
14)	Motor brake cable	MR-BKS1CBL □ M-A1-H Cable length: 2 * 5 * 10m		IP65 Load side lead Long flex life
15)	Motor brake cable	MR-BKS1CBL □ M-A2-L Cable length: 2 * 5 * 10m	 <p>Brake connector</p> <p>HF-KN series HF-KP□G1/G5/G7</p> <p>Refer to section 11.1.4 for details.</p>	IP65 Opposite-to-load side lead
16)	Motor brake cable	MR-BKS1CBL □ M-A2-H Cable length: 2 * 5 * 10m		IP65 Opposite-to-load side lead Long flex life
17)	Motor brake cable	MR-BKS2CBL03M-A1-L Cable length: 0.3m	 <p>Brake connector</p> <p>HF-KN series HF-KP□G1/G5/G7</p> <p>Refer to section 11.1.4 for details.</p>	IP55 Load side lead
18)	Motor brake cable	MR-BKS2CBL03M-A2-L Cable length: 0.3m	 <p>Brake connector</p> <p>HF-KN series HF-KP□G1/G5/G7</p> <p>Refer to section 11.1.4 for details.</p>	IP55 Opposite-to-load side lead
19)	Encoder cable	MR-J3ENCBL □ M-A1-L Cable length: 2 * 5 * 10m	 <p>Encoder connector</p> <p>HF-KN series HF-KP□G1/G5/G7</p> <p>Refer to section 11.1.2 (1) for details.</p>	IP65 Load side lead
20)	Encoder cable	MR-J3ENCBL □ M-A1-H Cable length: 2 * 5 * 10m		IP65 Load side lead Long flex life

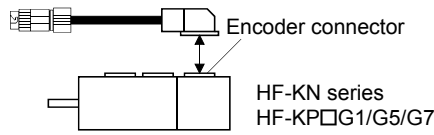
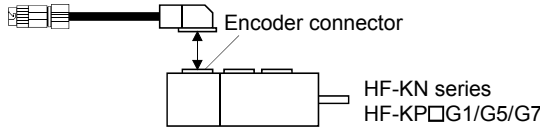
11. OPTIONS AND AUXILIARY EQUIPMENT

No.	Product	Model	Description	Application
21)	Encoder cable	MR-J3ENCBL □ M-A2-L Cable length: 2 · 5 · 10m	 Encoder connector HF-KN series HF-KP□G1/G5/G7	IP65 Opposite-to-load side lead
22)	Encoder cable	MR-J3ENCBL □ M-A2-H Cable length: 2 · 5 · 10m	Refer to section 11.1.2 (1) for details.	IP65 Opposite-to-load side lead Long flex life
23)	Encoder cable	MR-J3JCBL03M-A1-L Cable length: 0.3m	 Encoder connector HF-KN series HF-KP□G1/G5/G7	IP20 Load side lead
24)	Encoder cable	MR-J3JCBL03M-A2-L Cable length: 0.3m	 Encoder connector HF-KN series HF-KP□G1/G5/G7	IP20 Opposite-to-load side lead
25)	Encoder cable	MR-EKCBL □ M-L Cable length: 20 · 30m		IP20
26)	Encoder cable	MR-EKCBL □ M-H Cable length: 20 · 30 · 40 · 50m	For HF-KN series · HF-KP □ G1/G5/G7 Refer to section 11.1.2 (2) for details.	IP20 Long flex life
27)	Encoder connector set	MR-ECNM	 For HF-KN series · HF-KP □ G1/G5/G7 Refer to section 11.1.2 (2) for details.	IP20
28)	Encoder cable	MR-J3JSCBL03M-A1-L Cable length: 0.3m	 Encoder connector HF-KN series HF-KP□G1/G5/G7	IP65 Load side lead
29)	Encoder cable	MR-J3JSCBL03M-A2-L Cable length: 0.3m	 Encoder connector HF-KN series HF-KP□G1/G5/G7	IP65 Opposite-to-load side lead

11. OPTIONS AND AUXILIARY EQUIPMENT

No.	Product	Model	Description	Application
30)	Encoder cable	MR-J3ENSCBL □ M-L Cable length: 2 · 5 · 10 · 20 · 30m	 <p>For HF-KN series · HF-KP □ G1/G5/G7 Refer to section 11.1.2 (4) for details.</p>	IP67 Standard flex life
31)	Encoder cable	MR-J3ENSCBL □ M-H Cable length: 2 · 5 · 10 · 20 · 30 · 40 · 50m	<p>Refer to section 11.1.2 (4) for details.</p>	IP67 Long flex life
32)	Encoder connector set	MR-J3SCNS	 <p>For HF-KN series · HF-KP □ G1/G5/G7 Refer to section 11.1.2 (4) for details.</p>	IP67

11. OPTIONS AND AUXILIARY EQUIPMENT

11.1.2 Encoder cable/connector sets



(1) MR-J3ENCBL □ M-A1-L/H • MR-J3ENCBL □ M-A2-L/H

These are encoder cables for the HF-KN series • HF-KP □ G1/G5/G7 servo motors. The numerals in the Cable Length field of the table are the symbols entered in the □ part of the cable model. The cables of the lengths with the symbols are available.

Cable model	Cable length							IP rating	Flex life	Application
	2m	5m	10m	20m	30m	40m	50m			
MR-J3ENCBL □ M-A1-L	2	5	10	/	/	/	/	IP65	Standard	HF-KN series • HF-KP □ G1/G5/G7 servo motor Load side lead
MR-J3ENCBL □ M-A1-H	2	5	10	/	/	/	/	IP65	Long flex life	HF-KN series • HF-KP □ G1/G5/G7 servo motor Opposite-to-load side lead
MR-J3ENCBL □ M-A2-L	2	5	10	/	/	/	/	IP65	Standard	HF-KN series • HF-KP □ G1/G5/G7 servo motor Load side lead
MR-J3ENCBL □ M-A2-H	2	5	10	/	/	/	/	IP65	Long flex life	HF-KN series • HF-KP □ G1/G5/G7 servo motor Opposite-to-load side lead

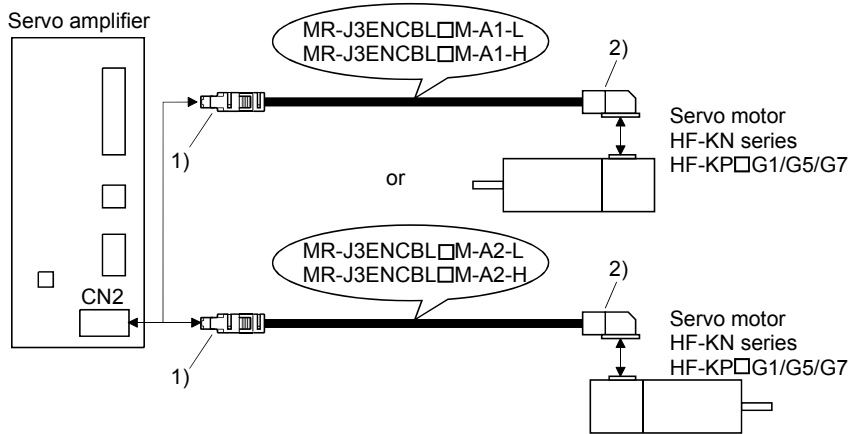
(a) Connection of servo amplifier and servo motor

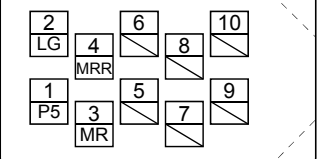
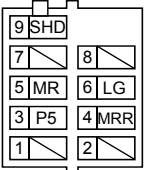
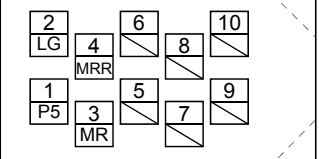

Cable model	1) For CN2 connector	2) For encoder connector
MR-J3ENCBL □ M-A1-L	Receptacle: 36210-0100PL Shell kit: 36310-3200-008 (3M) (Note) Signal layout 	Connector: 1674320-1 Crimping tool for ground clip: 1596970-1 Crimping tool for receptacle contact: 1596847-1 (Tyco Electronics) (Note) Signal layout 
MR-J3ENCBL □ M-A1-H	(Note) Signal layout 	
MR-J3ENCBL □ M-A2-L	View seen from wiring side.	
MR-J3ENCBL □ M-A2-H	Note. Keep open the pins shown with  . Especially, pin 10 is provided for manufacturer adjustment. If it is connected with any other pin, the servo amplifier cannot operate normally.	Note. Keep open the pins shown with  .

11. OPTIONS AND AUXILIARY EQUIPMENT

(b) Cable internal wiring diagram

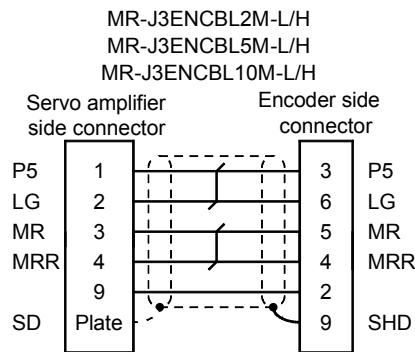

(2) MR-EKCBL □ M-L/H

POINT
<ul style="list-style-type: none"> ▪ The following encoder cables are of four-wire type. When using any of these encoder cables, set parameter No. PC22 to "1 □ □" to select the four-wire type. MR-EKCBL30M-L MR-EKCBL30M-H MR-EKCBL40M-H MR-EKCBL50M-H

The servo amplifier and servo motor cannot be connected with these cables only. The servo motor side encoder cable (MR-J3JCBL03M-A1-L or MR-J3JCBL03M-A2-L) is required.

The numerals in the Cable Length field of the table are the symbols entered in the □ part of the cable model. The cables of the lengths with the symbols are available.

Cable model	Cable length							IP rating	Flex life	Application
	2m	5m	10m	20m	30m	40m	50m			
MR-EKCBL □ M-L	/	/	/	20	(Note) 30	/	/	IP20	Standard	HF-KN series ▪ HF-KP □ G1/G5/G7 servo motor Use in combination with
MR-EKCBL □ M-H	/	/	/	20	(Note) 30	(Note) 40	(Note) 50	IP20	Long flex life	MR-J3JCBL03M-A1-L or MR-J3JCBL03M-A2-L.

Note. Four-wire type cable.

11. OPTIONS AND AUXILIARY EQUIPMENT

(a) Connection of servo amplifier and servo motor

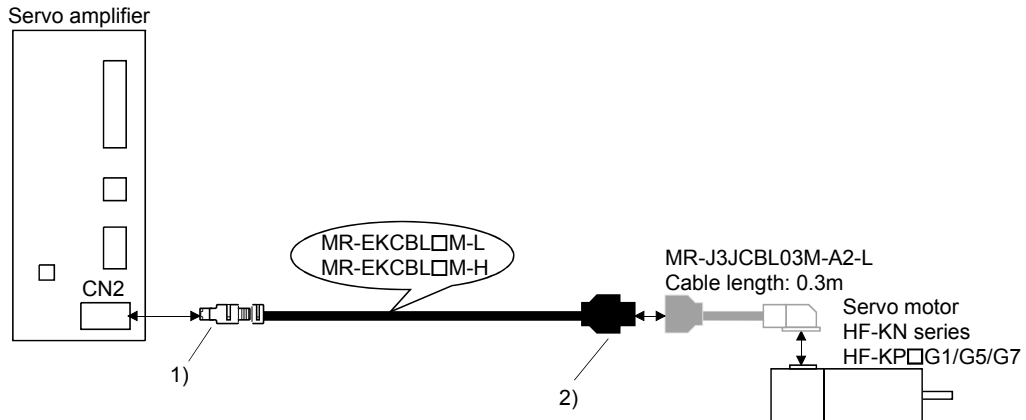

Cable model	1) CN2 connector	2) Junction connector
MR-EKCBL □ M-L	<p>Receptacle: 36210-0100PL Shell kit: 36310-3200-008 (3M)</p> <p>(Note) Signal layout</p> <p>View seen from wiring side.</p>	<p>Connector set: 54599-1019(Molex)</p> <p>Housing: 1-172161-9 Connector pin: 170359-1 (Tyco Electronics or equivalent) Cable clamp: MTI-0002 (Toa Electric Industries)</p> <p>(Note) Signal layout</p> <p>View seen from wiring side.</p>
MR-EKCBL □ M-H	<p>Note. Keep open the pins shown with . Especially, pin 10 is provided for manufacturer adjustment. If it is connected with any other pin, the servo amplifier cannot operate normally.</p>	<p>(Note) Signal layout</p> <p>View seen from wiring side.</p> <p>Note. Keep open the pin shown with an .</p>

11. OPTIONS AND AUXILIARY EQUIPMENT

(b) Internal wiring diagram

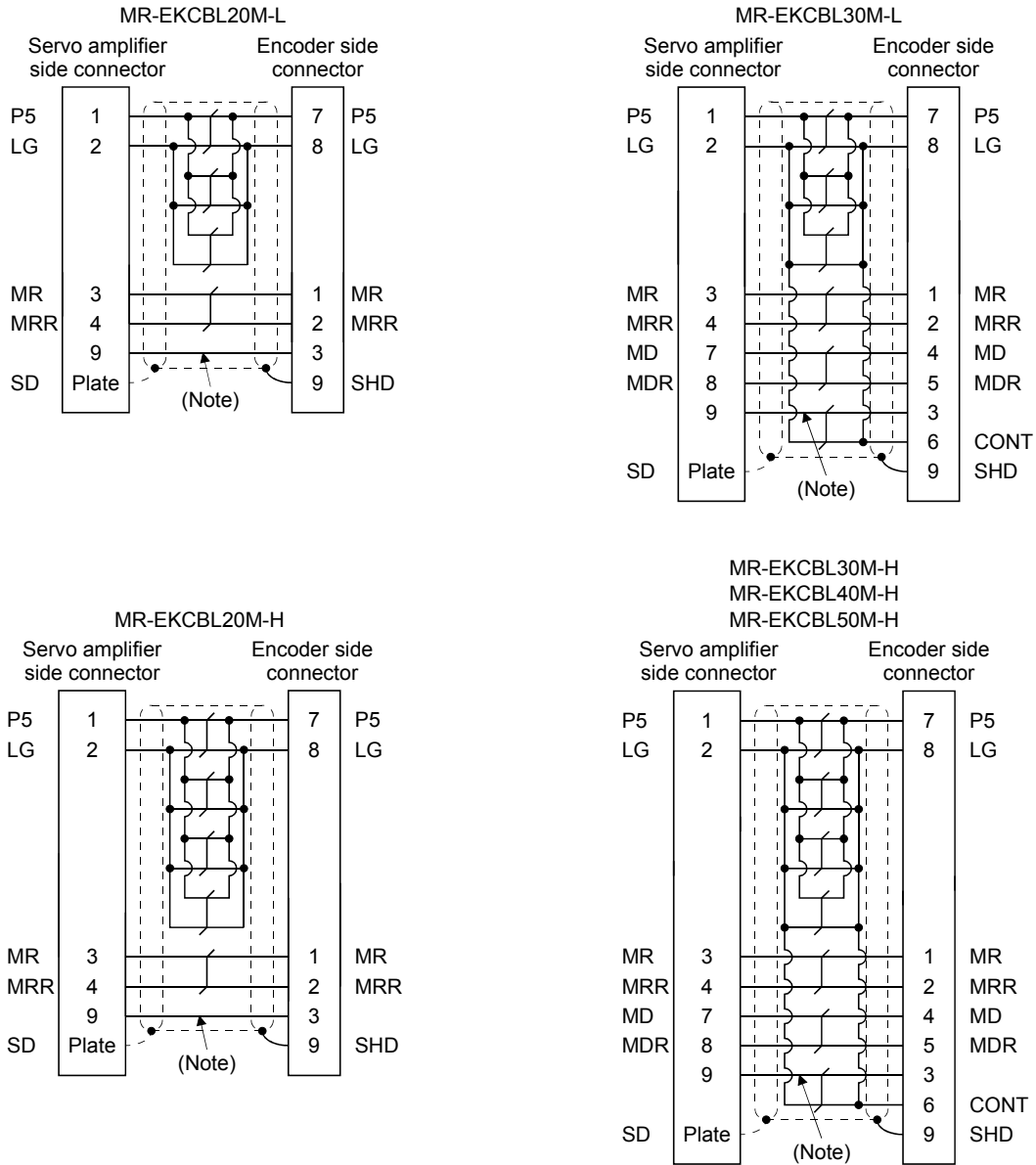

Note. When fabricating the cable, this wiring is not necessary.



When fabricating the cable, use the wiring diagram corresponding to the length indicated below.

Cable flex life	Applicable wiring diagram	
	Less than 30m	30m to 50m
Standard	MR-EKCBL20M-L	MR-EKCBL30M-H MR-EKCBL40M-H MR-EKCBL50M-H
Long flex life	MR-EKCBL20M-H	

11. OPTIONS AND AUXILIARY EQUIPMENT

(c) When fabricating the encoder cable

When fabricating the cable, prepare the following parts and tool, and fabricate it according to the wiring diagram in (b). Refer to section 11.5 for the specifications of the used cable.

Parts/Tool	Description										
Connector set	MR-ECNM (Option)										
	 										
	<table border="0"> <tr> <td>Servo amplifier side connector</td> <td>Encoder side connector</td> </tr> <tr> <td>Receptacle: 36210-0100PL</td> <td>Housing: 1-172161-9</td> </tr> <tr> <td>Shell kit: 36310-3200-008 (3M)</td> <td>Connector pin: 170359-1 (Tyco Electronics or equivalent)</td> </tr> <tr> <td>Or</td> <td>Cable clamp: MTI-0002 (Toa Electric Industries)</td> </tr> <tr> <td>Connector set: 54599-1019 (Molex)</td> <td></td> </tr> </table>	Servo amplifier side connector	Encoder side connector	Receptacle: 36210-0100PL	Housing: 1-172161-9	Shell kit: 36310-3200-008 (3M)	Connector pin: 170359-1 (Tyco Electronics or equivalent)	Or	Cable clamp: MTI-0002 (Toa Electric Industries)	Connector set: 54599-1019 (Molex)	
Servo amplifier side connector	Encoder side connector										
Receptacle: 36210-0100PL	Housing: 1-172161-9										
Shell kit: 36310-3200-008 (3M)	Connector pin: 170359-1 (Tyco Electronics or equivalent)										
Or	Cable clamp: MTI-0002 (Toa Electric Industries)										
Connector set: 54599-1019 (Molex)											

(3) MR-J3JCBL03M-A1-L • MR-J3JCBL03M-A2-L

The servo amplifier and servo motor cannot be connected with these cables only. The servo motor side encoder cable (MR-EKCBL □ M-L/H) is required.

Cable model	Cable length	IP rating	Flex life	Application
MR-J3JCBL03M-A1-L	0.3m	IP20	Standard	HF-KN series • HF-KP □ G1/G5/G7 servo motor Load side lead Use in combination with MR-EKCBL □ M-L/H.
MR-J3JCBL03M-A2-L				HF-KN series • HF-KP □ G1/G5/G7 servo motor Opposite-to-load side lead Use in combination with MR-EKCBL □ M-L/H.

11. OPTIONS AND AUXILIARY EQUIPMENT

(a) Connection of servo amplifier and servo motor

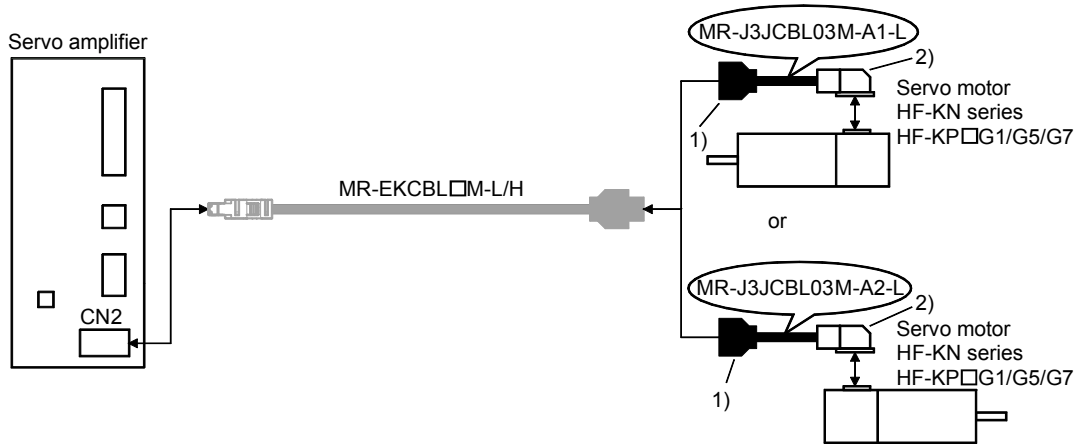

Cable model	1) Junction connector	2) For encoder connector
MR-J3JCBL03M-A1-L	Housing: 1-172169-9 Contact: 1473226-1 Cable clamp: 316454-1 Crimping tool: 91529-1 (Tyco Electronics)	Connector: 1674320-1 Crimping tool for ground clip: 1596970-1 Crimping tool for receptacle contact: 1596847-1 (Tyco Electronics)
MR-J3JCBL03M-A2-L	(Note) Signal layout View seen from wiring side. Note. Keep open the pins shown with .	(Note) Signal layout View seen from wiring side. Note. Keep open the pins shown with .

(b) Internal wiring diagram

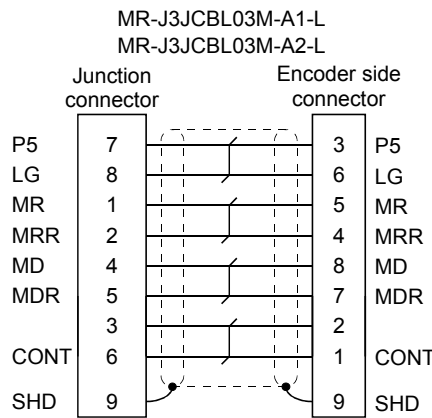

11. OPTIONS AND AUXILIARY EQUIPMENT

(4) MR-J3ENSCBL □ M-L • MR-J3ENSCBL □ M-H

The servo amplifier and servo motor cannot be connected with these cables only. The servo motor side encoder cable (MR-J3JSCBL03M-A1-L or MR-J3JSCBL03M-A2-L) is required. The number in the cable length column of the table indicates the symbol filling the square □ in the cable model. Cable lengths corresponding to the specified symbols are prepared.

Cable model	Cable length							IP rating	Flex life	Application
	2m	5m	10m	20m	30m	40m	50m			
MR-J3ENSCBL □ M-L	2	5	10	20	30	40	50	IP67	Standard	HF-KN series * HF-KP □ G1/G5/G7 servo motor Use in combination with MR-J3JSCBL03M-A1-L or MR-J3JSCBL03M-A2-L.
MR-J3ENSCBL □ M-H	2	5	10	20	30	40	50	IP67	Long flex life	

(a) Connection of servo amplifier and servo motor

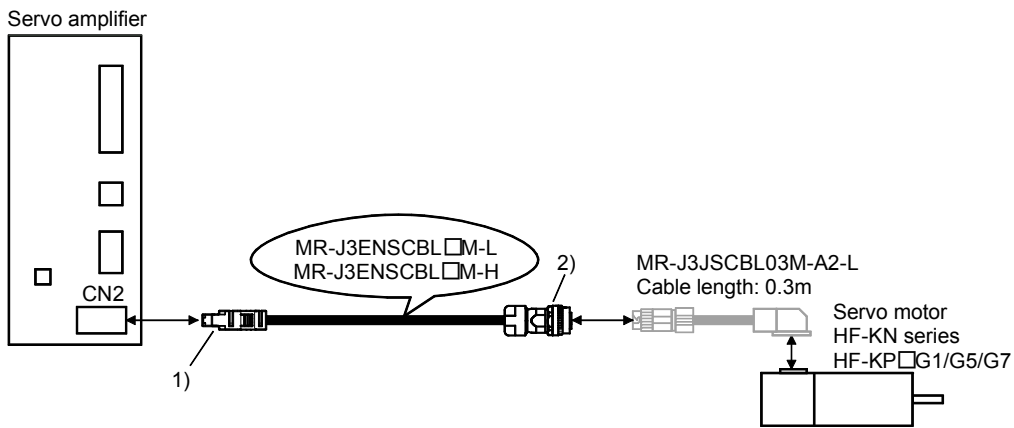

11. OPTIONS AND AUXILIARY EQUIPMENT

Cable model	1) For CN2 connector	2) Junction connector
MR-J3ENSCBL □ M-L	Receptacle: 36210-0100PL Shell kit: 36310-3200-008 (3M) (Note) Signal layout View seen from wiring side. Note. Keep open the pins shown with . Especially, pin 10 is provided for manufacturer adjustment. If it is connected with any other pin, the servo amplifier cannot operate normally.	Connector set: 54599-1019 (Molex) In case of 10m or shorter cables Straight plug: CM10-SP10S-M(D6) Socket contact: CM10-#22SC(C1) (D8)-100 Crimping tool: 357J-50446 (DDK) Applicable cable AWG20 to 22 In case of 20m or longer cables Straight plug: CM10-SP10S-M(D6) Socket contact: CM10-#22SC(C2) (D8)-100 Crimping tool: 357J-50447 (DDK) Applicable cable AWG23 to 28
MR-J3ENSCBL □ M-H		(Note) Signal layout View seen from wiring side. Note. Keep open the pins shown with .

(b) Internal wiring diagram

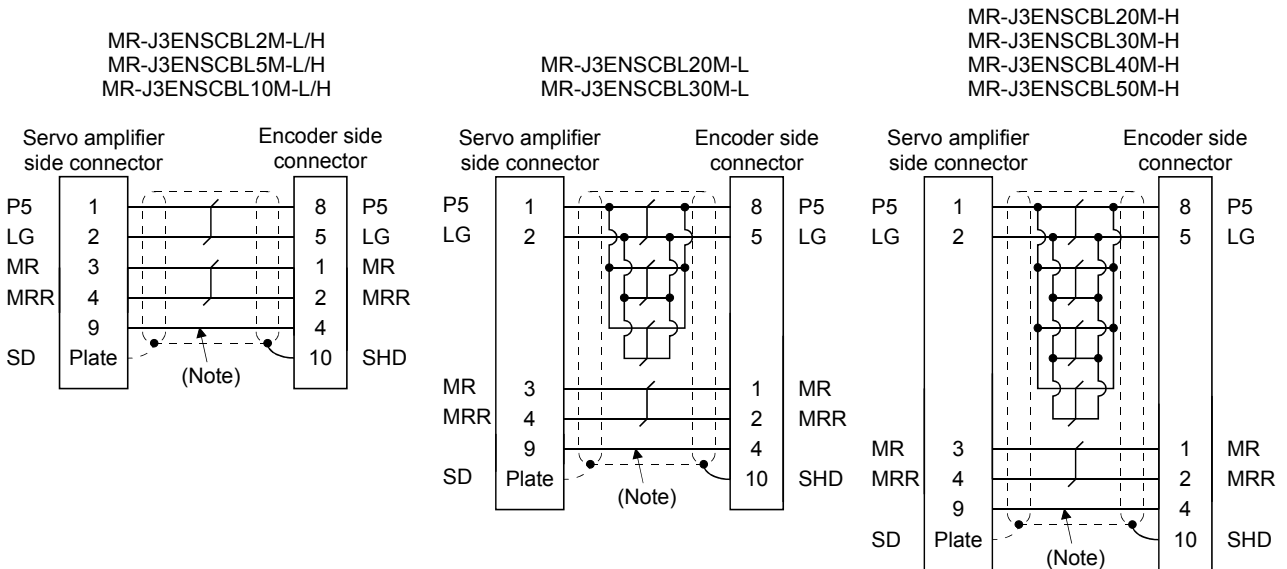



Note. When fabricating, this wiring is not necessary.

11. OPTIONS AND AUXILIARY EQUIPMENT

(c) When fabricating the encoder cable

When fabricating the cable, prepare the following parts and tool, and fabricate it according to the wiring diagram in (b). Refer to section 11.5 for the specifications of the used cable.

Parts/Tool (Connector set)	Description	
MR-J3SCNS (Option)		
	Servo amplifier side connector Receptacle: 36210-0100PL Shell kit: 36310-3200-008 (3M) Or Connector set: 54599-1019 (Molex)	Encoder side connector Straight plug: CM10-SP10S-M(D6) Socket contact: CM10-#22SC(S1)(D8)-100 Applicable wire size: AWG20 or less (DDK)

(5) MR-J3JSCBL03M-A1-L · MR-J3JSCBL03M-A2-L







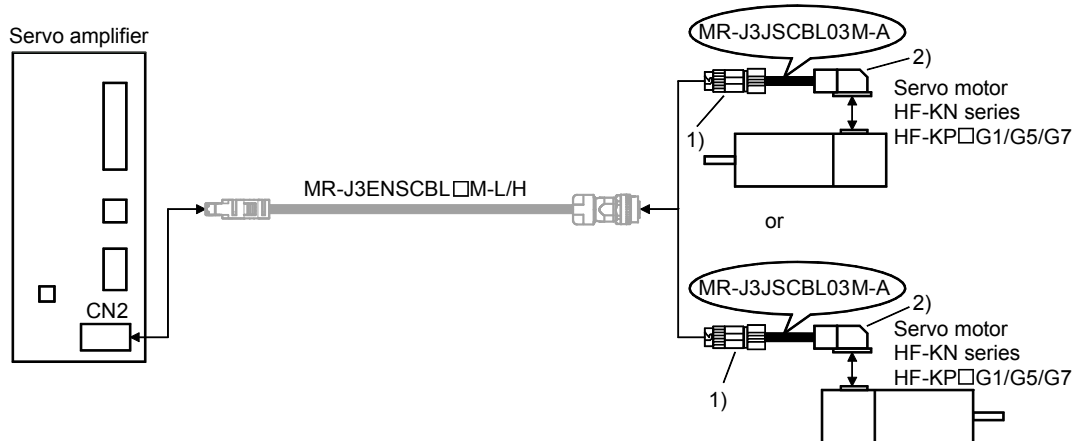

The servo amplifier and servo motor cannot be connected with these cables only. The servo motor side encoder cable (MR-J3ENSCBL □ M-L/H) is required.

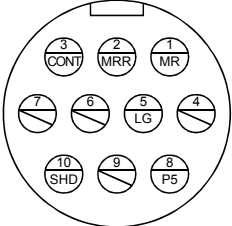
Cable model	Cable length	IP rating	Flex life	Application
MR-J3JSCBL03M-A1-L	0.3m	IP65	Standard	HF-KN series · HF-KP □ G1/G5/G7 servo motor Load side lead Use in combination with MR-J3ENSCBL □ M-L/H.
MR-J3JSCBL03M-A2-L				HF-KN series · HF-KP □ G1/G5/G7 servo motor Opposite-to-load side lead Use in combination with MR-J3ENSCBL □ M-L/H.

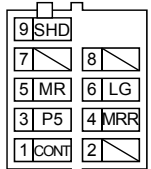
11. OPTIONS AND AUXILIARY EQUIPMENT

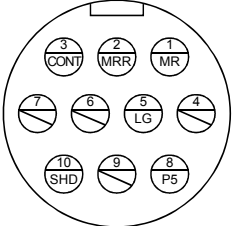
(a) Connection of servo amplifier and servo motor

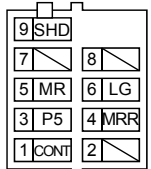

Cable model	1) Junction connector	2) For encoder connector
MR-J3JSCBL03M-A1-L	Receptacle: CM10-CR10P-M (DDK) Applicable cable AWG 20 or less (Note) Signal layout  View seen from wiring side. Note. Keep open the pins shown with  .	Connector: 1674320-1 Crimping tool for ground clip: 1596970-1 Crimping tool for receptacle contact: 1596847-1 (Tyco Electronics) (Note) Signal layout  View seen from wiring side. Note. Keep open the pins shown with  .
MR-J3JSCBL03M-A2-L	(Note) Signal layout  View seen from wiring side. Note. Keep open the pins shown with  .	Connector: 1674320-1 Crimping tool for ground clip: 1596970-1 Crimping tool for receptacle contact: 1596847-1 (Tyco Electronics) (Note) Signal layout  View seen from wiring side. Note. Keep open the pins shown with  .

(b) Internal wiring diagram

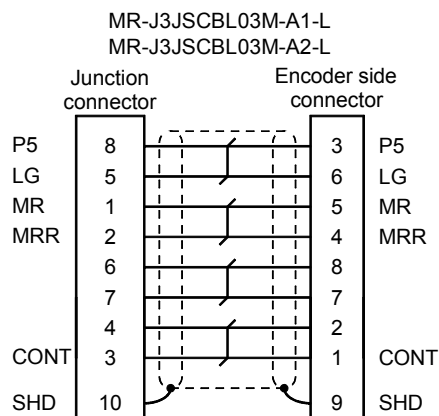

11. OPTIONS AND AUXILIARY EQUIPMENT

11.1.3 Motor power supply cables

These are motor power supply cables for the HF-KN series ▪ HF-KP □ G1/G5/G7 servo motors.

The numerals in the Cable Length field of the table are the symbols entered in the □ part of the cable model.

The cables of the lengths with the symbols are available.

Refer to section 3.10.2 when wiring.

Cable model	Cable length				IP rating	Flex life	Application
	0.3m	2m	5m	10m			
MR-PWS1CBL □ M-A1-L		2	5	10	IP65	Standard	HF-KN series ▪ HF-KP □ G1/G5/G7 servo motor Load side lead
MR-PWS1CBL □ M-A2-L		2	5	10	IP65	Standard	HF-KN series ▪ HF-KP □ G1/G5/G7 servo motor Opposite-to-load side lead
MR-PWS1CBL □ M-A1-H		2	5	10	IP65	Long flex life	HF-KN series ▪ HF-KP □ G1/G5/G7 servo motor Load side lead
MR-PWS1CBL □ M-A2-H		2	5	10	IP65	Long flex life	HF-KN series ▪ HF-KP □ G1/G5/G7 servo motor Opposite-to-load side lead
MR-PWS2CBL □ M-A1-L	03				IP55	Standard	HF-KN series ▪ HF-KP □ G1/G5/G7 servo motor Load side lead
MR-PWS2CBL □ M-A2-L	03				IP55	Standard	HF-KN series ▪ HF-KP □ G1/G5/G7 servo motor Opposite-to-load side lead

11. OPTIONS AND AUXILIARY EQUIPMENT

(1) Connection of servo amplifier and servo motor

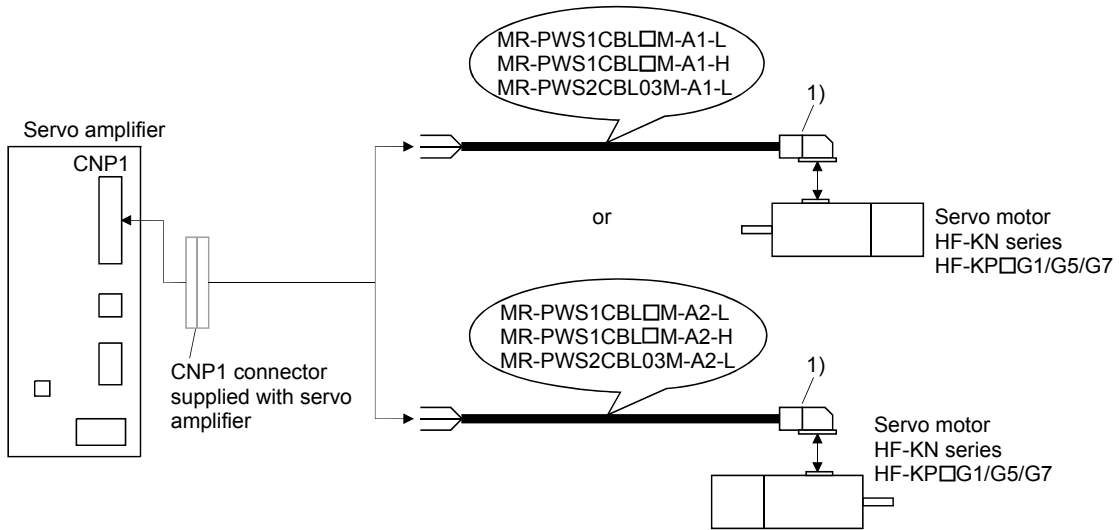

Cable model	1) For motor power supply connector	
MR-PWS1CBL □ M-A1-L	Connector: JN4FT04SJ1-R Hood, socket insulator Bushing, ground nut Contact: ST-TMH-S-C1B-100-(A534G) Crimping tool: CT160-3-TMH5B (Japan Aviation Electronics Industry)	<p>Signal layout</p> <p>View seen from wiring side.</p>
MR-PWS1CBL □ M-A2-L		
MR-PWS1CBL □ M-A1-H		
MR-PWS1CBL □ M-A2-H		
MR-PWS2CBL03M-A1-L	Connector: JN4FT04SJ2-R Hood, socket insulator Bushing, ground nut Contact: ST-TMH-S-C1B-100-(A534G) Crimping tool: CT160-3-TMH5B (Japan Aviation Electronics Industry)	
MR-PWS2CBL03M-A2-L		

(2) Internal wiring diagram

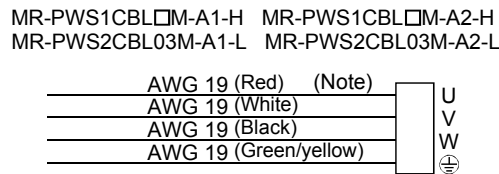

Note. These are not shielded cables.

11. OPTIONS AND AUXILIARY EQUIPMENT

11.1.4 Motor brake cables

These are motor brake cables for the HF-KN series ▪ HF-KP □ G1/G5/G7 servo motors. The numerals in the Cable Length field of the table are the symbols entered in the □ part of the cable model. The cables of the lengths with the symbols are available.

Refer to section 3.11.4 when wiring.

Cable model	Cable length				IP rating	Flex life	Application
	0.3m	2m	5m	10m			
MR-BKS1CBL □ M-A1-L		2	5	10	IP65	Standard	HF-KN series ▪ HF-KP □ G1/G5/G7 servo motor Load side lead
MR-BKS1CBL □ M-A2-L		2	5	10	IP65	Standard	HF-KN series ▪ HF-KP □ G1/G5/G7 servo motor Opposite-to-load side lead
MR-BKS1CBL □ M-A1-H		2	5	10	IP65	Long flex life	HF-KN series ▪ HF-KP □ G1/G5/G7 servo motor Load side lead
MR-BKS1CBL □ M-A2-H		2	5	10	IP65	Long flex life	HF-KN series ▪ HF-KP □ G1/G5/G7 servo motor Opposite-to-load side lead
MR-BKS2CBL □ M-A1-L	03				IP55	Standard	HF-KN series ▪ HF-KP □ G1/G5/G7 servo motor Load side lead
MR-BKS2CBL □ M-A2-L	03				IP55	Standard	HF-KN series ▪ HF-KP □ G1/G5/G7 servo motor Opposite-to-load side lead

11. OPTIONS AND AUXILIARY EQUIPMENT

(1) Connection of power supply for electromagnetic brake and servo motor

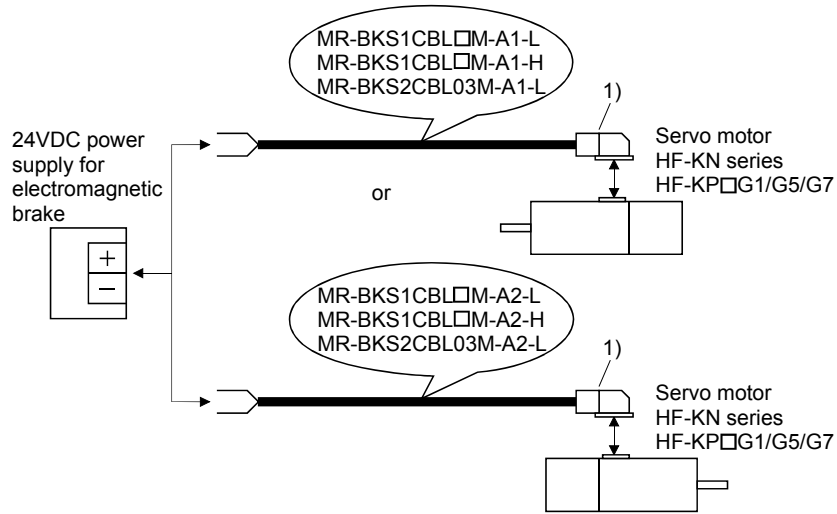

Cable model	1) For motor brake connector	
MR-BKS1CBL □ M-A1-L	Connector: JN4FT02SJ1-R Hood, socket insulator Bushing, ground nut	<p>Signal layout</p> <p>View seen from wiring side.</p>
MR-BKS1CBL □ M-A2-L		
MR-BKS1CBL □ M-A1-H	Contact: ST-TMH-S-C1B-100-(A534G)	
MR-BKS1CBL □ M-A2-H	Crimping tool: CT160-3-TMH5B (Japan Aviation Electronics Industry)	
MR-BKS2CBL03M-A1-L	Connector: JN4FT02SJ2-R Hood, socket insulator Bushing, ground nut	
MR-BKS2CBL03M-A2-L		

(2) Internal wiring diagram

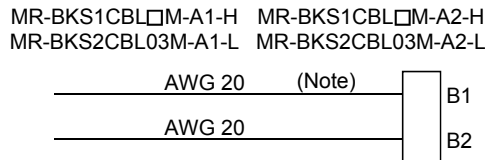

Note. These are not shielded cables.

11. OPTIONS AND AUXILIARY EQUIPMENT

11.2 Regenerative options

! CAUTION • The specified combinations of regenerative options and servo amplifiers may only be used. Otherwise, a fire may occur.

(1) Combination and regenerative power

The power values in the table are resistor-generated powers and not rated powers.

Servo amplifier	Regenerative power[W]		
	Built-in regenerative resistor	MR-RB032 [40Ω]	MR-RB12 [40Ω]
MR-JN-10A(1)		30	
MR-JN-20A(1)	10	30	100
MR-JN-40A	10	30	100

(2) Selection of the regenerative option

Use the following method when regeneration occurs continuously in vertical motion applications or when it is desired to make an in-depth selection of the regenerative option.

(a) Regenerative energy calculation

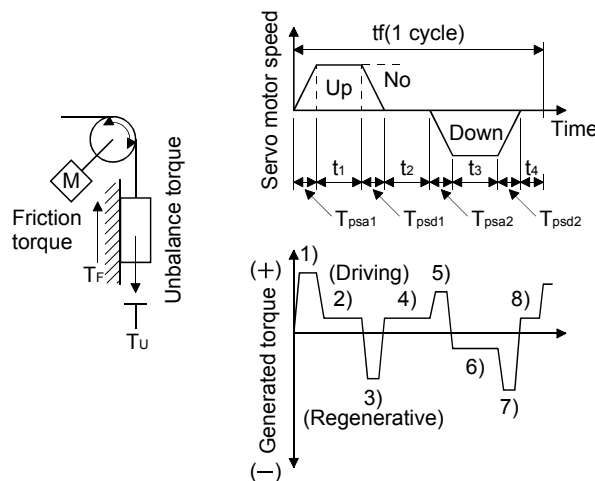

Formulas for calculating torque and energy in operation

Regenerative power	Torque applied to servo motor [N·m]	Energy [J]
1)	$T_1 = \frac{(J_L + J_M) \cdot N_0}{9.55 \times 10^4} \cdot \frac{1}{T_{psa1}} + T_U + T_F$	$E_1 = \frac{0.1047}{2} \cdot N_0 \cdot T_1 \cdot T_{psa1}$
2)	$T_2 = T_U + T_F$	$E_2 = 0.1047 \cdot N_0 \cdot T_2 \cdot t_1$
3)	$T_3 = \frac{-(J_L + J_M) \cdot N_0}{9.55 \times 10^4} \cdot \frac{1}{T_{psa1}} + T_U + T_F$	$E_3 = \frac{0.1047}{2} \cdot N_0 \cdot T_3 \cdot T_{psd1}$
4), 8)	$T_4 = T_U$	$E_4 \geq 0$ (No regeneration)
5)	$T_5 = \frac{(J_L + J_M) \cdot N_0}{9.55 \times 10^4} \cdot \frac{1}{T_{psa2}} - T_U + T_F$	$E_5 = \frac{0.1047}{2} \cdot N_0 \cdot T_5 \cdot T_{psa2}$
6)	$T_6 = -T_U + T_F$	$E_6 = 0.1047 \cdot N_0 \cdot T_6 \cdot t_3$
7)	$T_7 = \frac{-(J_L + J_M) \cdot N_0}{9.55 \times 10^4} \cdot \frac{1}{T_{psa2}} - T_U + T_F$	$E_7 = \frac{0.1047}{2} \cdot N_0 \cdot T_7 \cdot T_{psd2}$

From the calculation results in 1) to 8), find the absolute value (Es) of the sum total of negative energies.

11. OPTIONS AND AUXILIARY EQUIPMENT

(b) Losses of servo motor and servo amplifier in regenerative mode

The following table lists the efficiencies and other data of the servo motor and servo amplifier in the regenerative mode.

Servo amplifier	Inverse efficiency[%]	Capacitor charging[J]
MR-JN-10A	55	9
MR-JN-10A1	55	4
MR-JN-20A	70	9
MR-JN-20A1	70	4
MR-JN-40A	85	11

Inverse efficiency (η) :Efficiency including some efficiencies of the servo motor and servo amplifier when rated (regenerative) torque is generated at rated speed. Since the efficiency varies with the speed and generated torque, allow for about 10%.

Capacitor charging (E_c) :Energy charged into the electrolytic capacitor in the servo amplifier.

Subtract the capacitor charging from the result of multiplying the sum total of regenerative energies by the inverse efficiency to calculate the energy consumed by the regenerative option.

$$ER [J] = \eta \cdot E_s - E_c$$

Calculate the power consumption of the regenerative option on the basis of single-cycle operation period t_f [s] to select the necessary regenerative option.

$$PR [W] = ER/t_f$$

(3) Parameter setting

Set parameter No. PA02 according to the regenerative option to be used.

Parameter No. PA02

0		
---	--	--

Selection of regenerative option

00: Regenerative option is not used

•For servo amplifier of 100W, regenerative resistor is not used.

•For servo amplifier of 200 to 400W, built-in regenerative resistor is used.

02: MR-RB032

03: MR-RB12

11. OPTIONS AND AUXILIARY EQUIPMENT

(4) Connection of the regenerative option

POINT
<ul style="list-style-type: none">▪ When using a regenerative option, remove the built-in regenerative resistor and its wirings from the servo amplifier.▪ For the sizes of wires used for wiring, refer to section 11.5.▪ Avoid installing and removing the built-in regenerative resistor frequently, as much as possible.▪ When reinstalling the removed built-in regenerative resistor, check if there is no damage on the lead of the built-in regenerative resistor.

The regenerative option causes a temperature rise of 100°C relative to the ambient temperature. Fully examine heat dissipation, installation position and used wires, etc. before installing the option. For wiring, use flame-resistant wire and keep them clear of the regenerative option body. Always use twisted cables of max. 5m length for connection with the servo amplifier.

When using a regenerative option for MR-JN-20A(1) • MR-JN-40A, disconnect the wiring to P and C, remove the built-in regenerative resistor from the servo amplifier, and then connect the regenerative option to P and C. G3 and G4 are thermal sensor output terminals. G3-G4 is disconnected when the regenerative option overheats abnormally.

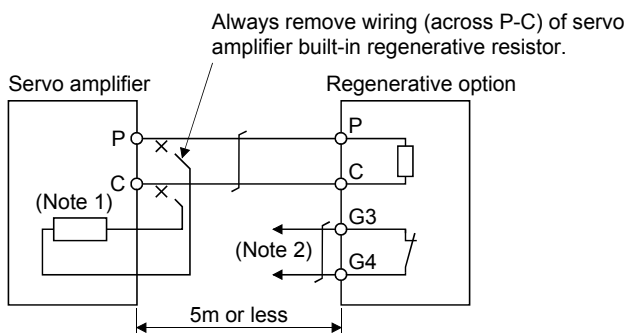

Note 1. A built-in regenerative resistor is not provided for the MR-JN-10A(1).

2. Make up a sequence which will switch off the magnetic contactor (MC) when abnormal heating occurs.

G3-G4 contact specifications
Maximum voltage: 120V AC/DC
Maximum current: 0.5A/4.8VDC
Maximum capacity: 2.4VA

Remove the built-in regenerative resistor in the procedures of 1) to 3), referring to the following diagram.

- 1) Disconnect the wires of the built-in regenerative resistor from the main circuit power supply connector (CNP1). (Refer to (3) in section 3.3.3)
- 2) Remove the wires of the built-in regenerative resistor from the servo amplifier, starting from the closest to the main circuit power supply connector (CNP1). At this time, be careful so as not to break the wires.

11. OPTIONS AND AUXILIARY EQUIPMENT

3) Remove the screw which fixes the built-in regenerative resistor, and then remove the built-in regenerative resistor.

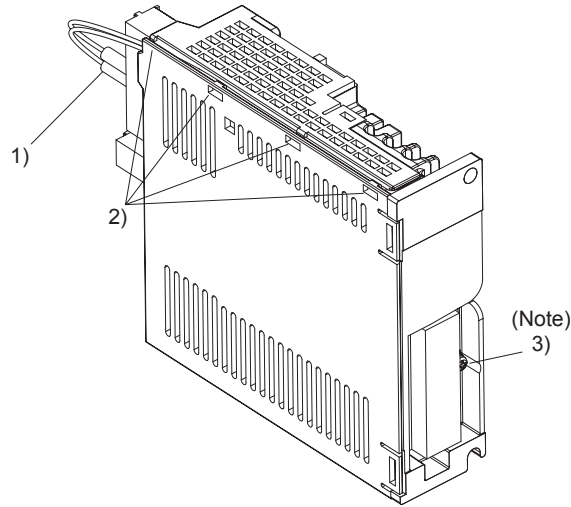

Note. Screw size: M3
Tightening torque: 0.72 [N · m]

(5) Outline dimension drawings

(a) MR-RB12

[Unit: mm]

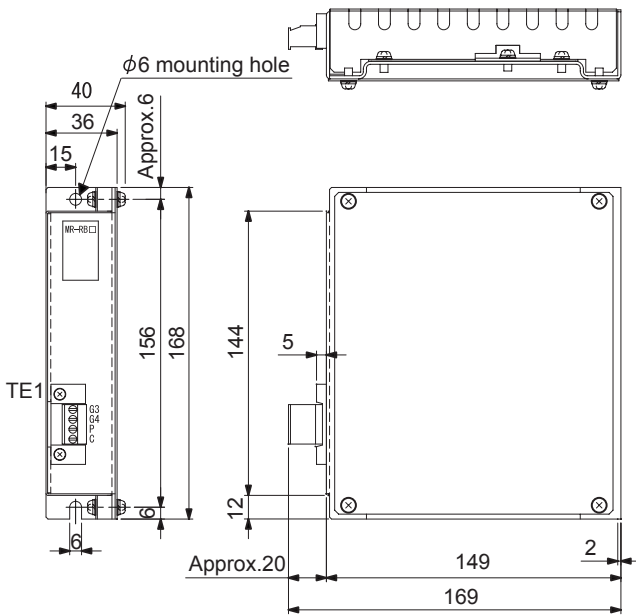

• TE1 terminal block

G3
G4
P
C

Applicable wire size: 0.2 to 2.5 [mm²]
(AWG24 to AWG12)
Tightening torque: 0.5 to 0.6 [N · m]
(4 to 5 [lb · in])

• Mounting screw

Screw: M5
Tightening torque: 3.24 [N · m] (28.7 [lb · in])

Mass: 1.1[kg] (2.4[lb])

11. OPTIONS AND AUXILIARY EQUIPMENT

(b) MR-RB032

[Unit: mm]

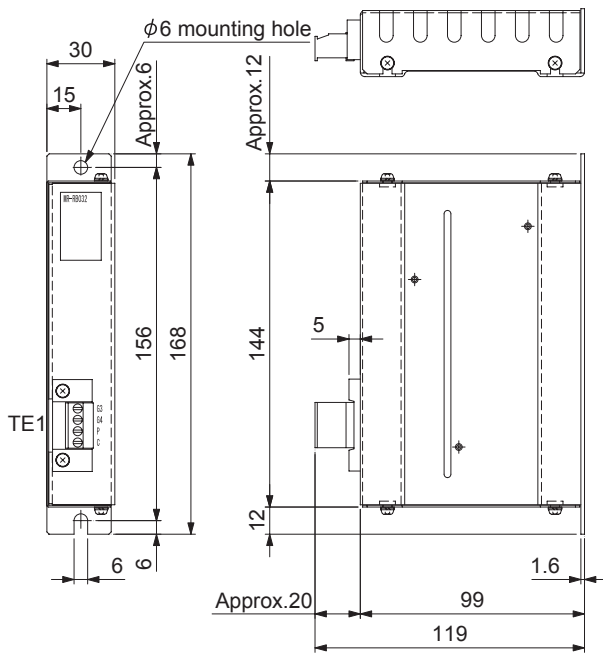

• TE1 terminal block

G3
G4
P
C

Applicable wire size: 0.2 to 2.5 [mm²]
(AWG24 to AWG12)

Tightening torque: 0.5 to 0.6 [N·m]
(4 to 5 [lb·in])

• Mounting screw

Screw: M5

Tightening torque: 3.24 [N·m] (28.7 [lb·in])

Mass: 0.5[kg] (1.1[lb])

11.3 Junction terminal block MR-TB26A

(1) How to use the junction terminal block

Always use the junction terminal block (MR-TB26A) with the junction terminal block cable (MR-TBNATBL □ M) as a set.

Use the junction terminal block by mounting it onto the DIN rail.

MR-TBNATBL □ M

Cable length:
05: 0.5m
1 : 1m

The terminal numbers described on the junction terminal block match the pin numbers of the servo amplifier's CN1 connector. S in the terminal number means a shield.

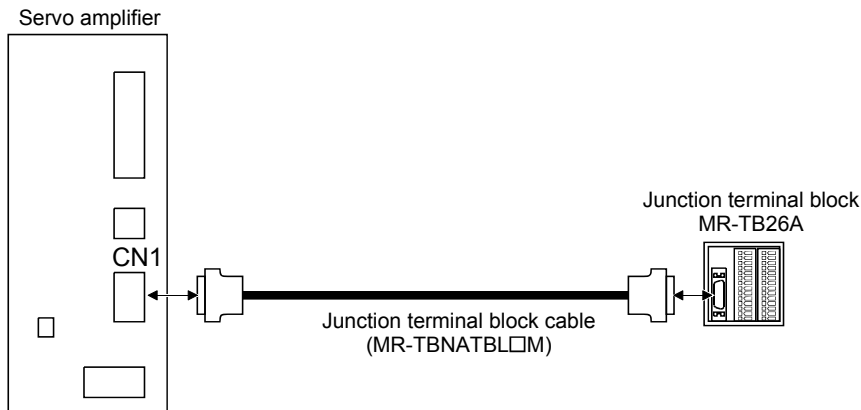

Ground the junction terminal block cable using the S terminal on the junction terminal block.

11. OPTIONS AND AUXILIARY EQUIPMENT

(2) Specifications

Junction terminal block		MR-TB26A
Rating		32VAC/DC 0.5A
applicable wires	Twisted wire	0.08 to 1.5mm ² (AWG28 to AWG14)
	Single wire	φ 0.32 to 1.2mm
	Outside diameter of the cable coating	φ Wires with 3.4 mm or less
Operation tools		Equivalent to 210-619 (manufactured by WAGO JAPAN) Equivalent to 210-119SB (manufactured by WAGO JAPAN)
Length of the removed coating		5 to 6 mm

(3) Outline drawing

[Unit: mm]

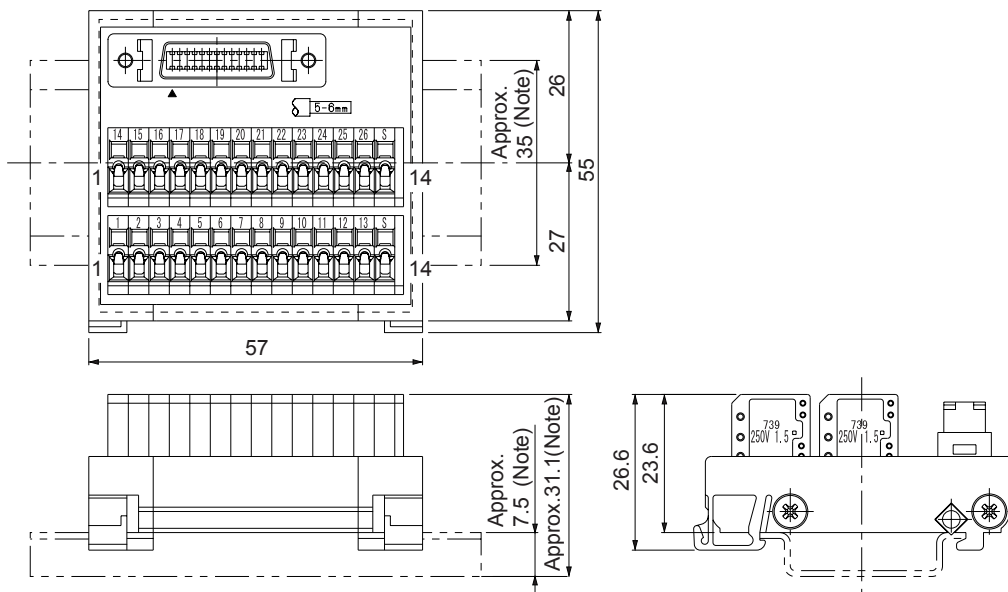

Note. The measure in () is applicable when a DIN 35mm rail is installed.

11. OPTIONS AND AUXILIARY EQUIPMENT

11.4 MR Configurator

POINT	
	▪ For the positioning mode, refer to section 13.8 to 13.10.

MR Configurator (MRZJW3-SETUP221E) performs parameter setting changes, graph display, test operation, etc. on a personal computer using the communication function of the servo amplifier.

(1) Specifications

Item	Description
Compatibility with a servo amplifier	The MR Configurator software version compatible with the servo amplifier is C3 or later. However, when using a servo amplifier compatible with the positioning mode, use MR Configurator with software version C4 or later.
Monitor	Display, Input/Output I/F display, high speed monitor, graph display (Minimum resolution changes with the processing speed of the personal computer.)
Alarm	Display, history, amplifier data
Diagnostic	No motor rotation, system information display, tuning data, Axis name setting.
Parameters	Parameter list, turning, change list, detailed information
Test operation	JOG operation, positioning operation, motor-less operation, DO forced output, program operation, single-step feed.
Point data	Point table (Refer to section 13.8.)
Program data	Program creation (Refer to section 13.9.)
File operation	Data read, save, delete, print
Others	Help display

11. OPTIONS AND AUXILIARY EQUIPMENT

(2) System configuration

(a) Components

To use this software, the following components are required in addition to the servo amplifier and servo motor.

Equipment	(Note 1) Description
(Note 2, 3) Personal computer	OS IBM PC/AT compatible where the English version of Windows® 98, Windows® Me, Windows® 2000 Professional, Windows® XP Professional, Windows® XP Home Edition, Windows Vista® Home Basic, Windows Vista® Home Premium, Windows Vista® Business, Windows Vista® Ultimate, Windows Vista® Enterprise, Windows® 7 Starter, Windows® 7 Home Premium, Windows® 7 Professional, Windows® Ultimate, Windows® Enterprise operates
	Processor Pentium® 133MHz or more (Windows® 98, Windows® 2000 Professional) Pentium® 150MHz or more (Windows® Me) Pentium® 300MHz or more (Windows® XP Professional, Windows® XP Home Edition) 32-bit (x86) processor of 1GHz or higher (Windows Vista® Home Basic, Windows Vista® Home Premium, Windows Vista® Business, Windows Vista® Ultimate, Windows Vista® Enterprise, Windows® 7 Starter, Windows® 7 Home Premium, Windows® 7 Professional, Windows® Ultimate, Windows® Enterprise)
	Memory 24MB or more (Windows® 98) 32MB or more (Windows® Me, Windows® 2000 Professional) 128MB or more (Windows® XP Professional, Windows® XP Home Edition) 512MB or more (Windows Vista® Home Basic) 1GB or more (Windows Vista® Home Premium, Windows Vista® Business, Windows Vista® Ultimate, Windows Vista® Enterprise, Windows® 7 Starter, Windows® 7 Home Premium, Windows® 7 Professional, Windows® Ultimate, Windows® Enterprise)
	Hard Disk 130MB or more of free space
Browser	Internet Explorer 4.0 or more
Display	One whose resolution is 1024 × 768 or more and that can provide a high color (16 bit) display. Connectable with the above personal computer.
Keyboard	Connectable with the above personal computer.
Mouse	Connectable with the above personal computer.
Printer	Connectable with the above personal computer.
USB cable	MR-J3USBCBL3M

Note 1. Windows and Windows Vista are the registered trademarks of Microsoft Corporation in the United States and other countries.
Pentium is the registered trademarks of Intel Corporation.

2. On some personal computers, MR Configurator may not run properly.
3. 64-bit Windows XP and 64-bit Windows Vista are not supported.

(b) Connection with servo amplifier

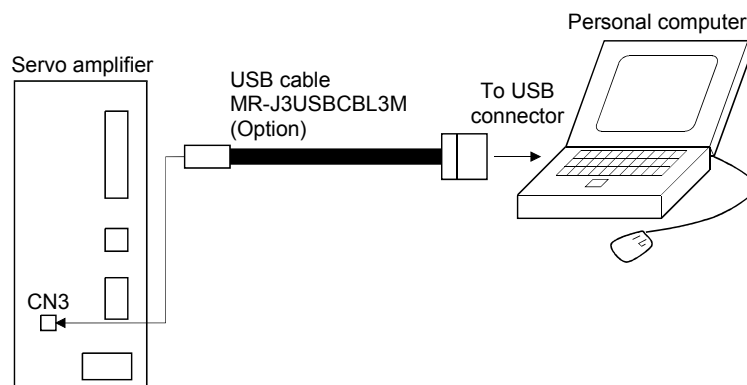

11. OPTIONS AND AUXILIARY EQUIPMENT

11.5 Selection example of wires

POINT
<ul style="list-style-type: none"> ▪ Wires indicated in this section are separated wires. When using a cable for power line (U, V, and W) between the servo amplifier and servo motor, use a 600V grade EP rubber insulated chloroprene sheath cab-tire cable (2PNCT). ▪ When complying with the UL/CSA standard, use the wires shown in App. 8 for wiring. To comply with other standards, use a wire that is complied with each standard. ▪ Selection condition of wire size is as follows. Construction condition: One wire is constructed in the air Wire length: 30m or less

(1) Wires for power supply wiring

The following diagram shows the wires used for wiring. Use the wires given in this section or equivalent.

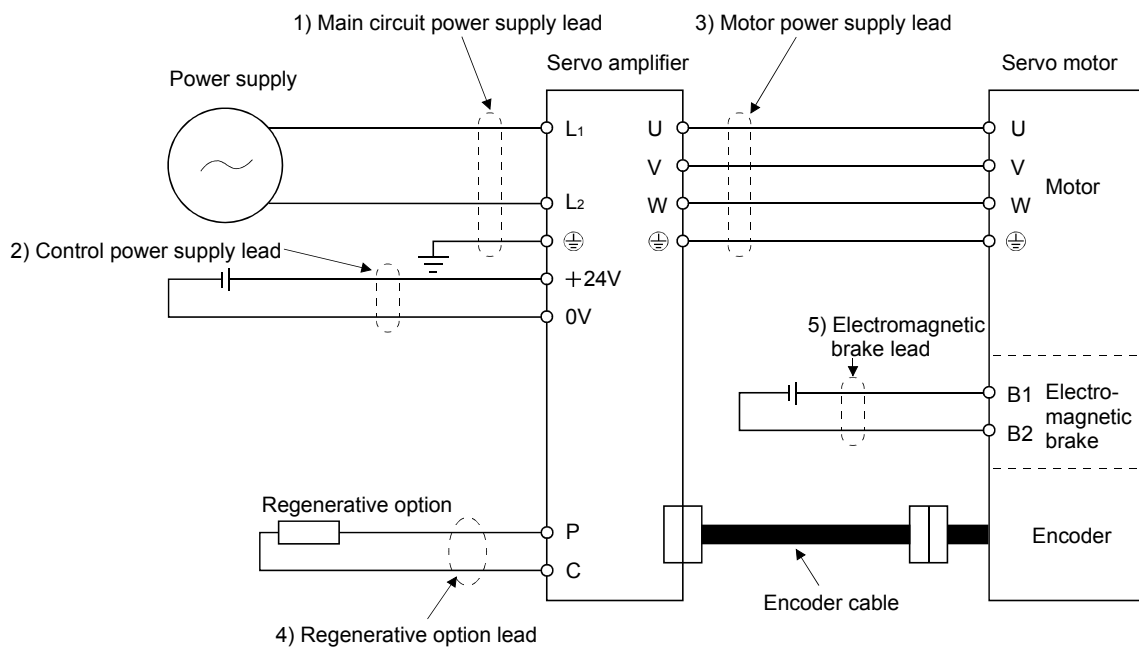

11. OPTIONS AND AUXILIARY EQUIPMENT

(a) When using the 600V Polyvinyl chloride insulated wire (IV wire)

Selection example of wire size when using IV wires is indicated below.

Table 11.1 Wire size selection example 1 (IV wire)

Servo amplifier	Wires [mm ²] (Note)				
	1) L ₁ · L ₂ · ⊕	2) +24V · 0V	3) U · V · W · ⊕	4) P · C	5) B1 · B2
MR-JN-10A(1)	2(AWG14)	2(AWG14)	2(AWG14)	2(AWG14)	1.25(AWG16)
MR-JN-20A(1)					
MR-JN-40A					

Note. Wires are selected based on the highest rated current among combining servo motors.

(b) When using the 600V Grade heat-resistant polyvinyl chloride insulated wire (HIV wire)

Selection example of wire size when using HIV wires is indicated below.

Table 11.2 Wire size selection example 2 (HIV wire)

Servo amplifier	Wires [mm ²] (Note)				
	1) L ₁ · L ₂ · ⊕	2) +24V · 0V	3) U · V · W · ⊕	4) P · C	5) B1 · B2
MR-JN-10A(1)	2(AWG14)	2(AWG14)	2(AWG14)	2(AWG14)	1.25(AWG16)
MR-JN-20A(1)					
MR-JN-40A					

Note. Wires are selected based on the highest rated current among combining servo motors.

11. OPTIONS AND AUXILIARY EQUIPMENT

(2) Wires for cables

When fabricating a cable, use the wire models given in the following table or equivalent.

Table 11.3 Wires for option cables

Type	Model	Length [m]	Core size	Number of Cores	Characteristics of one core			(Note 2) Finishing OD [mm]	Wire model
					Structure [Wires/mm]	Conductor resistance [Ω /km]	Insulation coating OD d [mm] (Note 1)		
Encoder cable	MR-J3ENCBL □ M-A1-L	2 to 10	AWG22	6 (3 pairs)	7/0.26	53 or less	1.2	7.1±0.3	(Note 3) VSVP 7/0.26 (AWG#22 or equivalent)-3P Ban-gi-shi-16823
	MR-J3ENCBL □ M-A2-L								
	MR-J3ENCBL □ M-A1-H	2 to 10	AWG22	6 (3 pairs)	70/0.08	56 or less	1.2	7.1±0.3	(Note 3) ETFE SVP 70/0.08 (AWG#22 or equivalent)-3P Ban-gi-shi-16824
	MR-J3ENCBL □ M-A2-H								
	MR-J3JCBLO3M-A1-L	0.3	AWG26	8 (4 pairs)	30/0.08	233 or less	1.2	7.1±0.3	(Note 5) T/2464-1061/IIA-SB 4P × 26AWG
	MR-J3JCBLO3M-A2-L								
	MR-EKCBL □ M-L	2 to 10	0.3mm ²	4 (2 pairs)	12/0.18	65.7 or less	1.3	7.3	(Note 3) 20276 composite 4-pair shielded cable (A-TYPE)
			0.08mm ²	4 (2 pairs)	7/0.127	234 or less	0.67		
		20 • 30	0.3mm ²	12 (6 pairs)	12/0.18	63.6 or less	1.2	8.2	UL 20276 AWG#23 6pair(BLACK)
	MR-EKCBL □ M-H	20	0.2mm ²	12 (6 pairs)	40/0.08	105 or less	0.88	7.2	(Note 3)A14B2343 6P
		30 to 50	0.2mm ²	14 (7 pairs)	40/0.08	105 or less	0.88	8.0	(Note 3)J14B0238(0.2*7P)
	MR-J3JSCBL03M-A1-L	0.3	AWG26	8 (4 pairs)	7/0.16	146 or less	1.0	7.1±0.3	(Note 3) VSVP 7/0.16(AWG#26 or equivalent)-4P Ban-gi-shi-16822
	MR-J3JSCBL03M-A2-L								
	MR-J3ENSCBL □ M-L	2 to 10	AWG22	6 (3 pairs)	7/0.26	53 or less	1.2	7.1±0.3	(Note 3) VSVP 7/0.26(AWG#22 or equivalent)-3P Ban-gi-shi-16823
20 • 30		AWG23	12 (6 pairs)	12/0.18	63.3 or less	1.2	8.2±0.3	(Note 3) 20276 VSVCAWG#23×6P Ban-gi-shi-15038	
MR-J3ENSCBL □ M-H	2 to 10	AWG22	6 (3 pairs)	70/0.08	56 or less	1.2	7.1±0.3	(Note 3) ETFE • SVP 70/0.08(AWG#22 or equivalent)-3P Ban-gi-shi-16824	
	20 to 50	AWG24	12 (6 pairs)	40/0.08	105 or less	0.88	7.2	(Note 3) ETFE • SVP 40/0.08mm × 6P Ban-gi-shi-15266	
Motor power supply cable	MR-PWS1CBL □ M-A1-L	2 to 10	AWG18	4	34/0.18	21.8 or less	1.71	6.2±0.3	HRZFEV-A(CL3) AWG18 4 cores
	MR-PWS1CBL □ M-A2-L	2 to 10							
	MR-PWS1CBL □ M-A1-H	2 to 10	(Note 6) AWG19 (0.75mm ²)	4	150/0.08	29.1 or less	1.63	5.7±0.5	(Note 4) RMFES-A(CL3X) AWG19 4 cores
	MR-PWS1CBL □ M-A2-H	2 to 10							
	MR-PWS2CBL03M-A1-L	0.3	AWG19	4	30/0.18	25.8 or less	1.64	—	(Note 3, 7) J11B2330 UL 10125
MR-PWS2CBL03M-A2-L	0.3								

11. OPTIONS AND AUXILIARY EQUIPMENT

Type	Model	Length [m]	Core size	Number of Cores	Characteristics of one core			(Note 2) Finishing OD [mm]	Wire model
					Structure [Wires/mm]	Conductor resistance [Ω /km]	Insulation coating OD d [mm] (Note 1)		
Motor brake cable	MR-BKS1CBL □ M-A1-L	2 to 10	AWG20	2	21/0.18	34.6 or less	1.35	4.7±0.1	HRZFEV-A(CL3) AWG20 2 cores
	MR-BKS1CBL □ M-A2-L	2 to 10							
	MR-BKS1CBL □ M-A1-H	2 to 10	(Note 6) AWG20	2	110/0.08	39.0 or less	1.37	4.5±0.3	(Note 4) RMFES-A(CL3X) AWG20 2 cores
	MR-BKS1CBL □ M-A2-H	2 to 10							
	MR-BKS2CBL03M-A1-L	0.3	AWG20	2	19/0.203	32.0 or less	1.42	—	(Note 3, 7) J11B331 UL 10125
	MR-BKS2CBL03M-A2-L	0.3							

Note 1. d is as shown below.

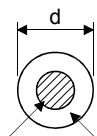

Conductor Insulation sheath

2. Standard OD. Max. OD is about 10% greater.
3. Purchase from Toa Electric Industry
4. Purchase from Taisei
5. Taiyo Electric Wire and Cable
6. These wire sizes assume that the UL-compliant wires are used at the wiring length of 10m.
7. This model is for a single wire. The color must be specified separately.

11.6 No-fuse breakers, fuses, magnetic contactors

Always use one no-fuse breaker and one magnetic contactor with one servo amplifier. When using a fuse instead of the no-fuse breaker, use the one having the specifications given in this section.

Servo amplifier	No-fuse breaker			Fuse			(Note 2) Magnetic contactor
	Current [A]		Voltage AC [V]	(Note 1) Class	Current [A]	Voltage AC [V]	
	Not using power factor improving reactor	Using power factor improving reactor					
MR-JN-10A	30A frame 5A	30A frame 5A	240V	T	10A	300V	S-N10
MR-JN-20A/10A1	30A frame 10A	30A frame 10A			15A		
MR-JN-40A/20A1	30A frame 15A	30A frame 10A			20A		

Note 1. When not using the servo amplifier as a UL/CSA Standard compliant product, K5 class fuse can be used.

2. Be sure to use a magnetic contactor (MC) with an operation delay time of 80ms or less. The operation delay time is the time interval between current being applied to the coil until closure of contacts.

11. OPTIONS AND AUXILIARY EQUIPMENT

11.7 Power factor improving AC reactor FR-HAL

The power factor improving AC reactor FR-HAL increases the form factor of the servo amplifier's input current to improve the power factor. It can reduce the power capacity. The input power factor is improved to be about 88%.

It is also effective to reduce the input side harmonics.

When using the power factor improving AC reactors FR-HAL for two or more servo amplifiers, be sure to connect a power factor improving AC reactor FR-HAL to each servo amplifier. If using one power factor improving AC reactor FR-HAL for multiple servo amplifiers, enough improvement effect of phase factor cannot be obtained unless all servo amplifiers are operated.

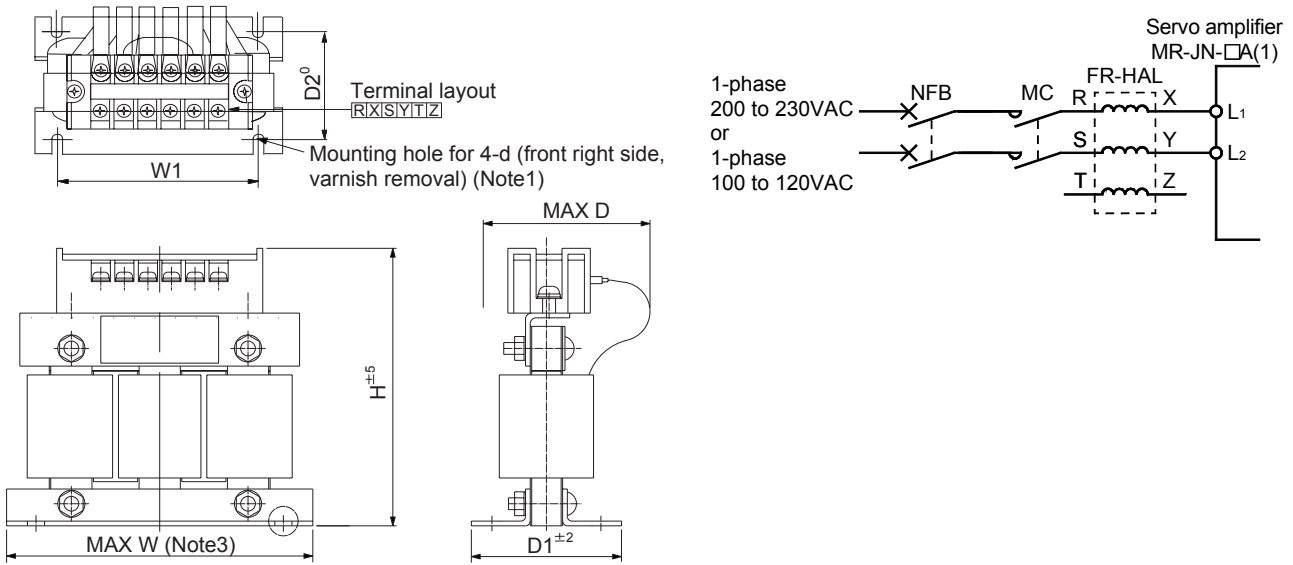

Servo amplifier	Power factor improving AC reactor (FR-HAL)	Dimensions [mm]							Terminal screw size	Crimping terminal	Mass [kg (lb)]
		W	W1	H	D (Note 2)	D1	D2	d			
MR-JN-10A/20A/10A1	FR-HAL-0.75K	104	84	99	74	56	44	M5	M4	2-4	0.8 (1.76)
MR-JN-40A/20A1	FR-HAL-1.5K	104	84	99	77	61	50	M5	M4	2-4	1.1 (2.43)

Note 1. Use any of the mounting holes for grounding.

2. Maximum dimension (The dimension varies depending on the bending degree of the I/O line.)

3. $W \pm 2$

11.8 Relays (recommended)

The following relays should be used with the interfaces.

Interface	Selection example
Digital input signal (interface DI-1) Relay used for open/close signals	To prevent defective contacts use a relay for small signal (twin contacts). (Ex.) Omron : type G2A , MY
Digital output signal (interface DO-1) Relay used for signals	Small relay with 12VDC or 24VDC of rated current 40mA or less (Ex.) Omron : type MY

11. OPTIONS AND AUXILIARY EQUIPMENT

11.9 Noise reduction techniques

Noises are classified into external noises which enter the servo amplifier to cause it to malfunction and those radiated by the servo amplifier to cause peripheral devices to malfunction. Since the servo amplifier is an electronic device which handles small signals, the following general noise reduction techniques are required. Also, the servo amplifier can be a source of noise as its outputs are chopped by high carrier frequencies. If peripheral devices malfunction due to noises produced by the servo amplifier, noise suppression measures must be taken. The measures will vary slightly with the routes of noise transmission.

(1) Noise reduction techniques

(a) General reduction techniques

- Avoid laying power lines (input and output cables) and signal cables side by side or do not bundle them together. Separate power lines from signal cables.
- Use shielded, twisted pair cables for connection with the encoder and for control signal transmission, and connect the shield to the SD terminal.
- Ground the servo amplifier, servo motor, etc. together at one point (refer to section 3.12).

(b) Reduction techniques for external noises that cause the servo amplifier to malfunction

If there are noise sources (such as a magnetic contactor, an electromagnetic brake, and many relays which make a large amount of noise) near the servo amplifier and the servo amplifier may malfunction, the following countermeasures are required.

- Provide surge absorbers on the noise sources to suppress noises.
- Attach data line filters to the signal cables.
- Ground the shields of the encoder connecting cable and the control signal cables with cable clamp fittings.
- Although a surge absorber is built into the servo amplifier, to protect the servo amplifier and other equipment against large exogenous noise and lightning surge, attaching a varistor to the power input section of the equipment is recommended.

(c) Techniques for noises radiated by the servo amplifier that cause peripheral devices to malfunction

Noises produced by the servo amplifier are classified into those radiated from the cables connected to the servo amplifier and its main circuits (input and output circuits), those induced electromagnetically or statically by the signal cables of the peripheral devices located near the main circuit cables, and those transmitted through the power supply cables.

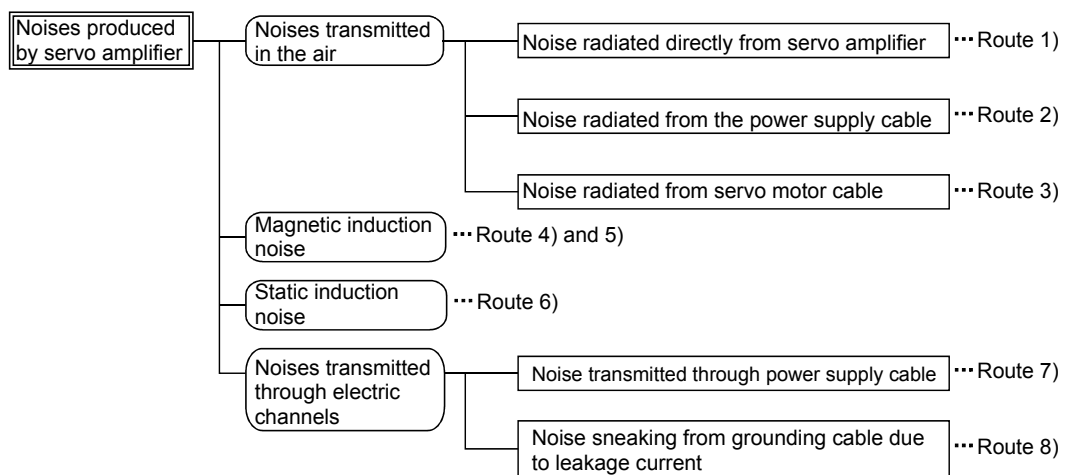

11. OPTIONS AND AUXILIARY EQUIPMENT

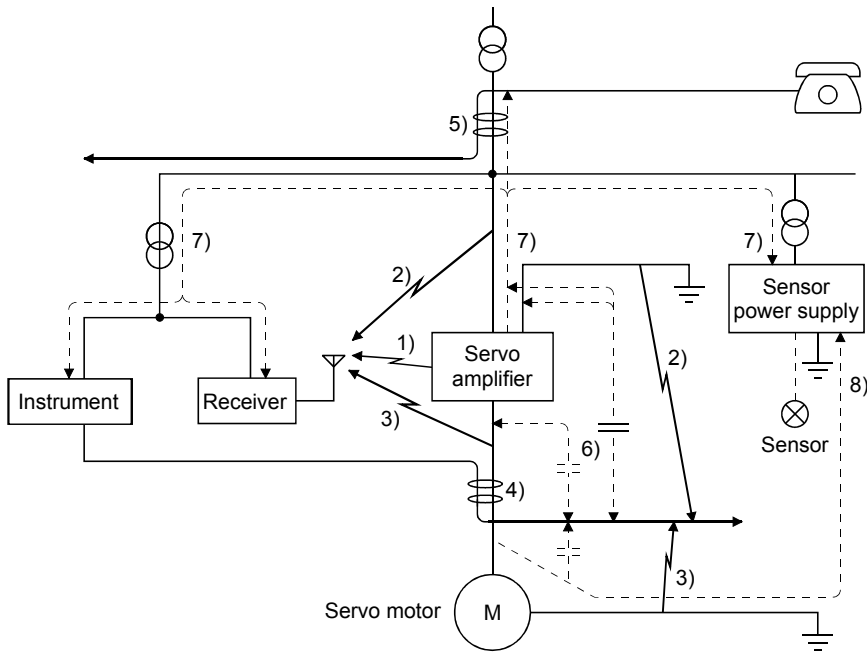

Noise transmission route	Suppression techniques
1) 2) 3)	<p>When measuring instruments, receivers, sensors, etc. which handle weak signals and may malfunction due to noise and/or their signal cables are contained in a control box together with the servo amplifier or run near the servo amplifier, such devices may malfunction due to noises transmitted through the air. The following techniques are required.</p> <ol style="list-style-type: none"> 1. Provide maximum clearance between easily affected devices and the servo amplifier. 2. Provide maximum clearance between easily affected signal cables and the I/O cables of the servo amplifier. 3. Avoid laying the power lines (Input cables of the servo amplifier) and signal cables side by side or bundling them together. 4. Insert a line noise filter to the I/O cables or a radio noise filter on the input line. 5. Use shielded wires for signal and power cables or put cables in separate metal conduits.
4) 5) 6)	<p>When the power lines and the signal cables are laid side by side or bundled together, magnetic induction noise and static induction noise will be transmitted through the signal cables and malfunction may occur. The following techniques are required.</p> <ol style="list-style-type: none"> 1. Provide maximum clearance between easily affected devices and the servo amplifier. 2. Provide maximum clearance between easily affected signal cables and the I/O cables of the servo amplifier. 3. Avoid laying the power lines (I/O cables of the servo amplifier) and signal cables side by side or bundling them together. 4. Use shielded wires for signal and power cables or put the cables in separate metal conduits.
7)	<p>When the power supply of peripheral devices is connected to the power supply of the servo amplifier system, noises produced by the servo amplifier may be transmitted back through the power supply cable and the devices may malfunction. The following techniques are required.</p> <ol style="list-style-type: none"> 1. Insert the radio noise filter (FR-BIF) on the power cables (Input cables) of the servo amplifier. 2. Insert the line noise filter (FR-BSF01) on the power cables of the servo amplifier.
8)	<p>When the cables of peripheral devices are connected to the servo amplifier to make a closed loop circuit, leakage current may flow to malfunction the peripheral devices. If so, malfunction may be prevented by disconnecting the grounding cable of the peripheral device.</p>

11. OPTIONS AND AUXILIARY EQUIPMENT

(2) Noise reduction products

(a) Data line filter (Recommended)

Noise can be prevented by installing a data line filter onto the encoder cable, etc.

For example, the ZCAT3035-1330 of TDK and the ESD-SR-250 of NEC TOKIN make are available as data line filters.

As a reference example, the impedance specifications of the ZCAT3035-1330 (TDK) are indicated below.

These impedances are reference values and not guaranteed values.

Impedance [Ω]	
10 to 100MHz	100 to 500MHz
80	150

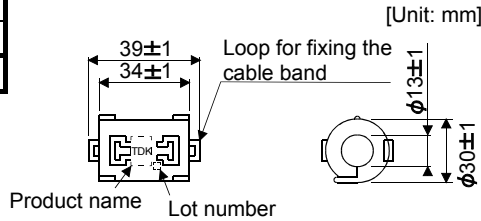

Outline drawing (ZCAT3035-1330)

(b) Surge suppressor (Recommended)

The recommended surge suppressor for installation to an AC relay, AC valve or the like near the servo amplifier is shown below. Use this product or equivalent.

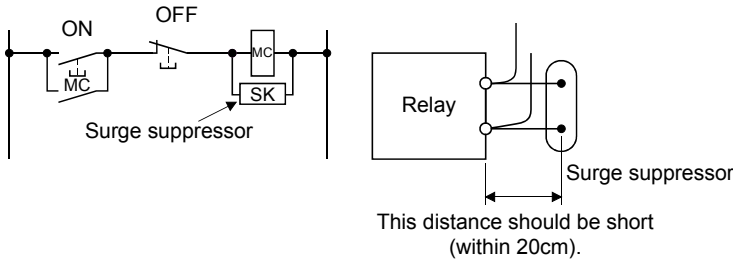

(Ex.)972A-2003 50411
(Matsuo Electric Co.,Ltd.)

Rated voltage AC[V]	C[μ F]	R[Ω]	Test voltage AC[V]
200	0.5	50(1W)	Across T-C 1000 (1 to 5s)

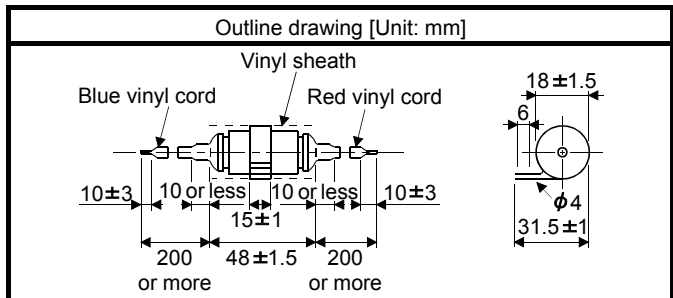

Note that a diode should be installed to a DC relay, DC valve or the like.

Maximum voltage: Not less than 4 times the drive voltage of the relay or the like

Maximum current: Not less than twice the drive current of the relay or the like

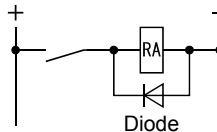

11. OPTIONS AND AUXILIARY EQUIPMENT

(c) Cable clamp fitting (AERSBAN-□SET)

Generally, the earth of the shielded cable may only be connected to the connector's SD terminal. However, the effect can be increased by directly connecting the cable to an earth plate as shown below. Install the earth plate near the servo amplifier for the encoder cable. Peel part of the cable sheath to expose the external conductor, and press that part against the earth plate with the cable clamp. If the cable is thin, clamp several cables in a bunch.

The clamp comes as a set with the earth plate.

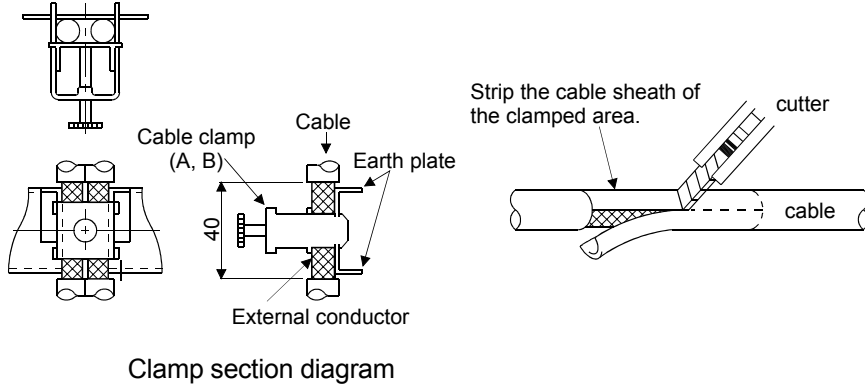

• Outline drawing

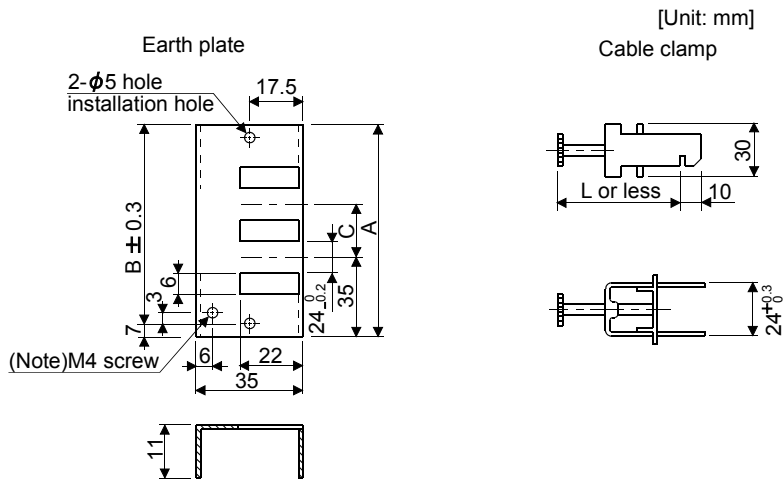

Note. Screw hole for grounding. Connect it to the earth plate of the control box.

Type	A	B	C	Accessory fittings	Cable clamp	L
AERSBAN-DSET	100	86	30	Cable clamp A: 2pcs.	A	70
AERSBAN-ESET	70	56		Cable clamp B: 1pc.	B	45

11. OPTIONS AND AUXILIARY EQUIPMENT

(d) Line noise filter (FR-BSF01)

This filter is effective in suppressing noises radiated from the power supply side and output side of the servo amplifier and also in suppressing high-frequency leakage current (zero-phase current) especially within 0.5MHz to 5MHz band.

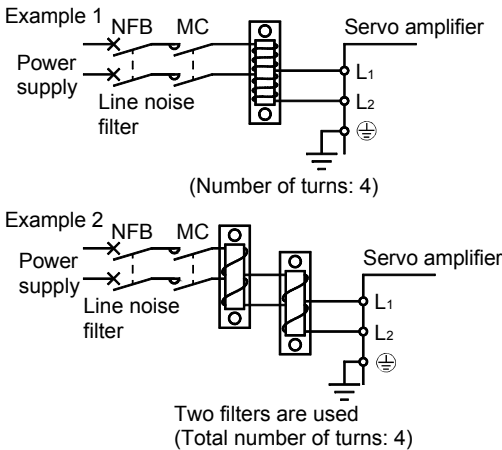
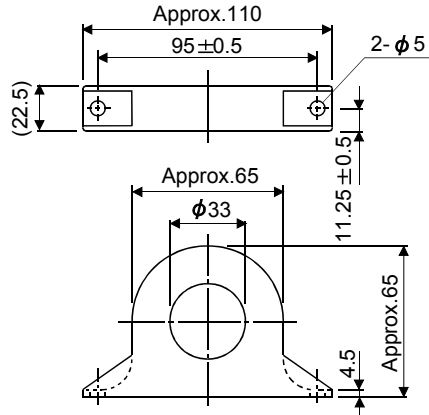
Connection diagram	Outline drawing [Unit: mm]
<p>Use the line noise filters for wires of the main power supply (L₁ L₂) and of the motor power supply (U V W). Pass each of wires through the line noise filter an equal number of times in the same direction. For the main power supply, the effect of the filter rises as the number of passes increases, but generally four passes would be appropriate. For the motor power supply, passes must be four times or less. Do not pass the grounding (earth) wire through the filter, or the effect of the filter will drop. Wind the wires by passing through the filter to satisfy the required number of passes as shown in Example 1. If the wires are too thick to wind, use two or more filters to have the required number of passes as shown in Example 2.</p> <p>Place the line noise filters as close to the servo amplifier as possible for their best performance.</p>  <p>Example 1 (Number of turns: 4)</p> <p>Example 2 Two filters are used (Total number of turns: 4)</p>	<p>FR-BSF01 (for wire size 3.5mm² (AWG12) or less)</p> 

11. OPTIONS AND AUXILIARY EQUIPMENT

(e) Radio noise filter (FR-BIF)

This filter is effective in suppressing noises radiated from the power supply side of the servo amplifier especially in 10MHz and lower radio frequency bands. The FR-BIF is designed for the input only.

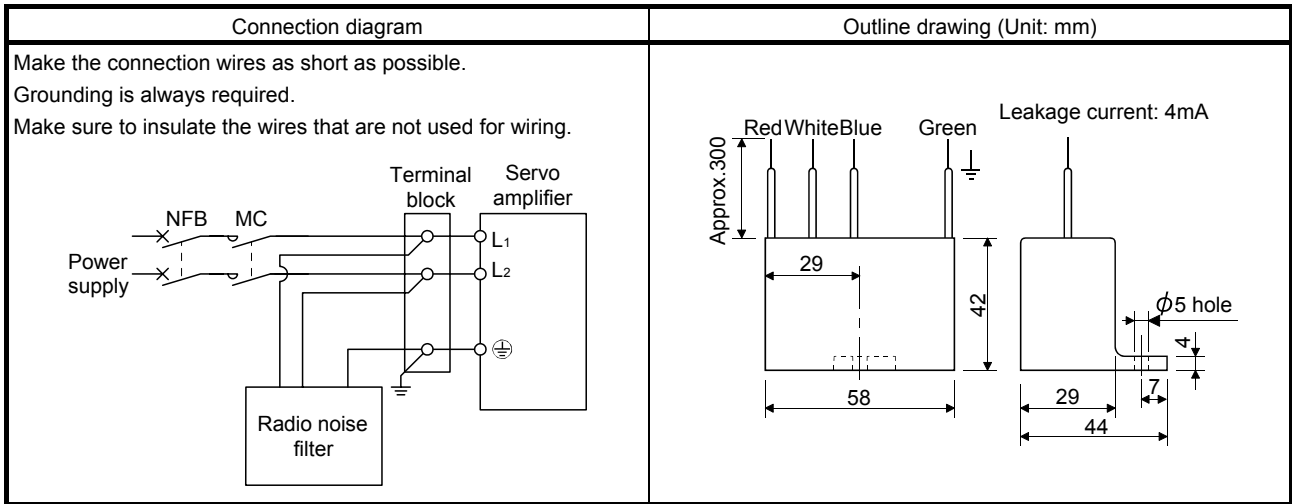

(f) Varistors for input power supply (Recommended)

Varistors are effective to prevent exogenous noise and lightning surge from entering the servo amplifier. When using a varistor, connect it between each phase of the input power supply of the equipment. For varistors, the TND20V-431K and TND20V-471K, manufactured by NIPPON CHEMI-CON, are recommended. For detailed specification and usage of the varistors, refer to the manufacturer catalog.

Power supply voltage	Varistor	Maximum rating					Maximum limit voltage		Static capacity (reference value)	Varistor voltage rating (range) V1mA
		Permissible circuit voltage		Surge current immunity	Energy immunity	Rated pulse power				
		AC[V _{rms}]	DC[V]	8/20μs[A]	2ms[J]	[W]	[A]	[V]	[pF]	[V]
100V class	TND20V-431K	275	350	10000/1 time 7000/2 time	195	1.0	100	710	1300	430(387 to 473)
200V class	TND20V-471K	300	385		215			775	1200	470(423 to 517)

[Unit: mm]

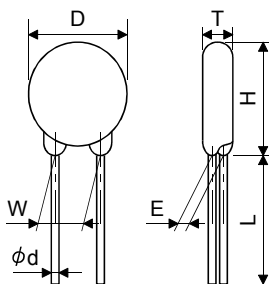

Model	D Max.	H Max.	T Max.	E ±1.0	(Note)L min.	φd ±0.05	W ±1.0
TND20V-431K	21.5	24.5	6.4	3.3	20	0.8	10.0
TND20V-471K			6.6				

Note. For special purpose items for lead length (L), contact the manufacturer.

11. OPTIONS AND AUXILIARY EQUIPMENT

11.10 Leakage current breaker

(1) Selection method

High-frequency chopper currents controlled by pulse width modulation flow in the AC servo circuits. Leakage currents containing harmonic contents are larger than those of the motor which is run with a commercial power supply.

Select a leakage current breaker according to the following formula, and ground the servo amplifier, servo motor, etc. securely.

Make the input and output cables as short as possible, and also make the grounding cable as long as possible (about 30cm) to minimize leakage currents.

$$\text{Rated sensitivity current} \geq 10 \cdot \{I_{g1} + I_{gn} + I_{ga} + K \cdot (I_{g2} + I_{gm})\} \text{ [mA]} \dots\dots\dots (11.1)$$

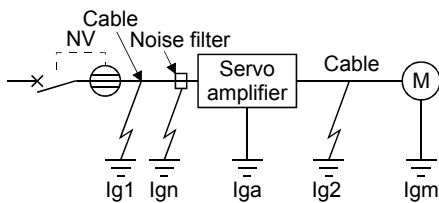

Leakage current breaker		K
Type	Mitsubishi products	
Models provided with harmonic and surge reduction techniques	NV-SP	1
	NV-SW	
	NV-CP	
	NV-CW	
	NV-HW	
General models	BV-C1	3
	NFB	
	NV-L	

Ig1: Leakage current on the electric channel from the leakage current breaker to the input terminals of the servo amplifier (Found from Fig. 11.1.)

Ig2: Leakage current on the electric channel from the output terminals of the servo amplifier to the servo motor (Found from Fig. 11.1.)

Ign: Leakage current when a filter is connected to the input side (4.4mA per one FR-BIF)

Iga: Leakage current of the servo amplifier (Found from Fig. 11.5.)

Igm: Leakage current of the servo motor (Found from Fig. 11.4.)

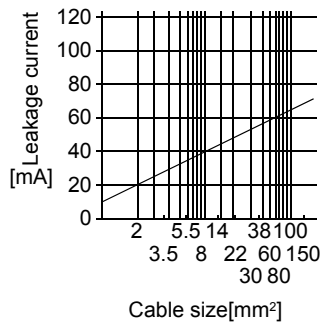

Fig. 11.1 Leakage current example (Ig1, Ig2) for CV cable run in metal conduit

11. OPTIONS AND AUXILIARY EQUIPMENT

Table 11.4 Servo motor's leakage current example (I_{gm})

Servo motor power [kW]	Leakage current [mA]
0.05 to 0.4	0.1

Table 11.5 Servo amplifier's leakage current example (I_{ga})

Servo amplifier capacity [kW]	Leakage current [mA]
0.1 to 0.4	0.1

Table 11.6 Leakage circuit breaker selection example

Servo amplifier	Rated sensitivity current of leakage circuit breaker [mA]
MR-JN-10A(1)/20A(1)/40A	15

(2) Selection example

Indicated below is an example of selecting a leakage current breaker under the following conditions.

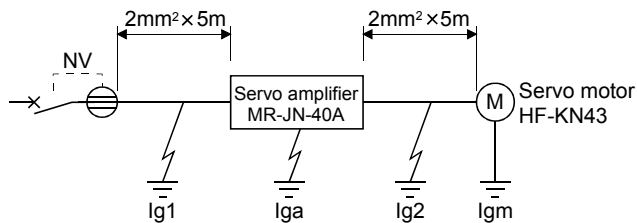

Use a leakage current breaker generally available.

Find the terms of Equation (11.1) from the diagram.

$$I_{g1} = 20 \cdot \frac{5}{1000} = 0.1 \text{ [mA]}$$

$$I_{g2} = 20 \cdot \frac{5}{1000} = 0.1 \text{ [mA]}$$

$$I_{gn} = 0 \text{ (not used)}$$

$$I_{ga} = 0.1 \text{ [mA]}$$

$$I_{gm} = 0.1 \text{ [mA]}$$

Insert these values in Equation (11.1).

$$I_g \geq 10 \cdot \{0.1+0+0.1+1 \cdot (0.1+0.1)\}$$

$$\geq 4.0 \text{ [mA]}$$

According to the result of calculation, use a leakage current breaker having the rated sensitivity current (I_g) of 4.0[mA] or more. A leakage current breaker having I_g of 15[mA] is used with the NV-SP/SW/CP/CW/HW series.

11. OPTIONS AND AUXILIARY EQUIPMENT

11.11 Circuit protector

Use the circuit protector for the control circuit power supply (+24V, 0V).

Servo amplifier	Circuit protector
MR-JN-10A(1)	CP30-BA2P1M3A
MR-JN-20A(1)	
MR-JN-40A	

11.12 EMC filter (recommended)

For compliance with the EMC directive of the EN Standard, it is recommended to use the following filter. Some EMC filters are large in leakage current.

(1) Combination with the servo amplifier

Servo amplifier	Recommended filter (Soshin Electric)		Mass [kg]([lb])
	Model	Leakage current [mA]	
MR-JN-10A(1)	(Note) HF3010A-UN	5	3 (6.61)
MR-JN-20A(1)			
MR-JN-40A			

Note. A surge protector is separately required to use any of these EMC filters. (Refer to section 11.13.)

(2) Connection example

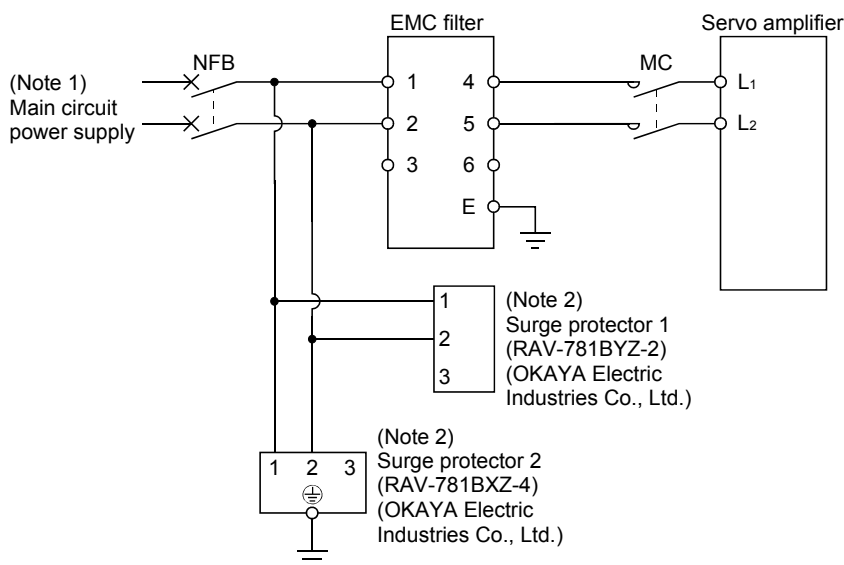

Note 1. Refer to section 1.3 for the power supply specification.

Note 2. The example is when a surge protector is connected.

11. OPTIONS AND AUXILIARY EQUIPMENT

(3) Outline drawing HF3010A-UN

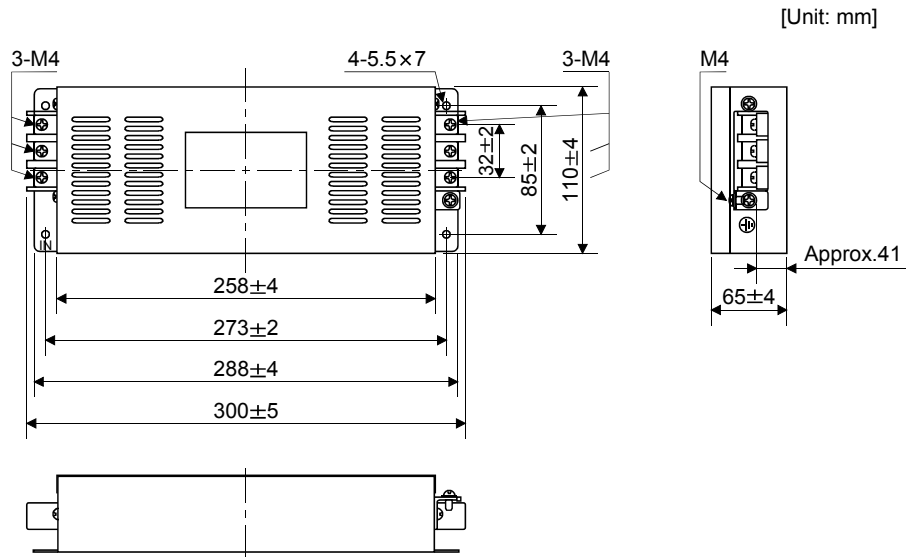

11.13 Surge protector (recommended)

To avoid damages caused by surges (such as lightning and sparking) applied on AC power line, connecting the following surge protectors to the main circuit power (L1 • L2) is recommended.

(1) Specifications

Surge protector model	Circuit voltage 50/60Hz	Maximum permissible circuit voltage	Clamp voltage	Surge immunity 8/20μs	Surge compression 1.2/50μs	Static capacity	Operating temperature
RAV-781BYZ-2	3AC 250V	300V	783V±10%	2500A	20kV	75pF	-20 to 70°C
RAV-781BXZ-4	3AC 250V	300V	1700V±10%	2500A	2kV	75pF	-20 to 70°C

11. OPTIONS AND AUXILIARY EQUIPMENT

(2) Outline drawing RAV-781BYZ-2

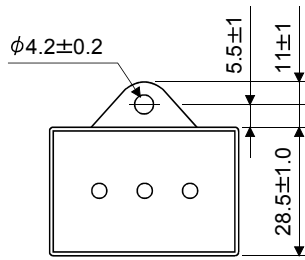

[Unit: mm]

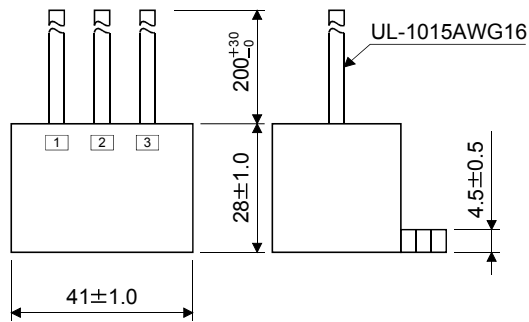
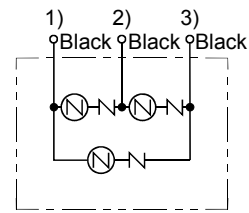

RAV-781BXZ-4

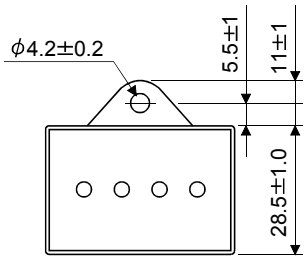

[Unit: mm]

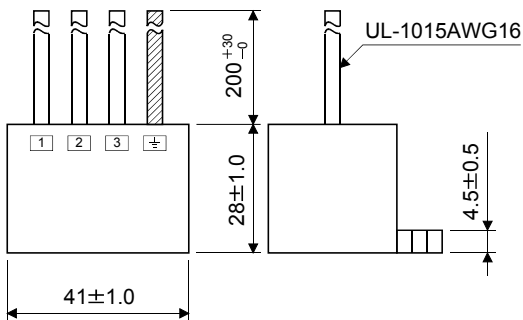
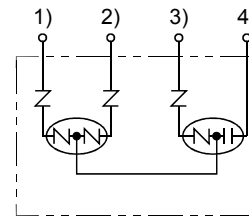

11. OPTIONS AND AUXILIARY EQUIPMENT

11.14 MR-HDP01 manual pulse generator

POINT
<ul style="list-style-type: none"> For the positioning mode, PP and NP are not assigned in the initial status. Assign PP or NP in parameter No. PD02. (Refer to section 4.4.2.)

In the positioning mode, MR-HDP01 manual pulse generator can be used to operate the servo motor. The manual pulse generator input multiplication can be set in parameter No. PE02.

(1) Specifications

Item		Specifications
Power	Voltage	4.5VDC to 13.2VDC
	Current consumption	60mA or lower
Interface		Output current max. 20mA for open collector output
Pulse signal form		A-phase, B-phase, 2 signals of 90 phase difference
Pulse resolution		100 pulse/rev
Max. speed		600r/min moment, 200r/min normally
Operating temperature range		-10°C to 60°C (14°F to 140°F)
Storage temperature range		-30°C to 80°C (-22°F to 176°F)

(2) Connection example

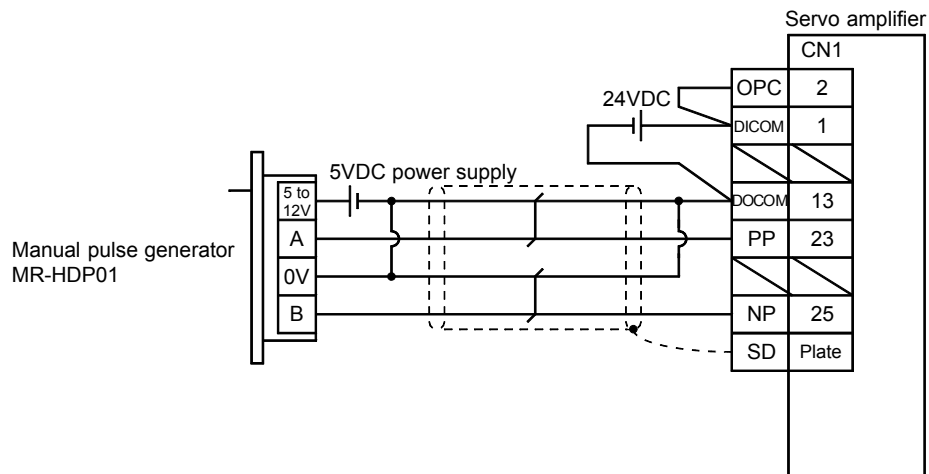

12. SERVO MOTOR

12. SERVO MOTOR

12.1 Introduction

12.1.1 Rating plate

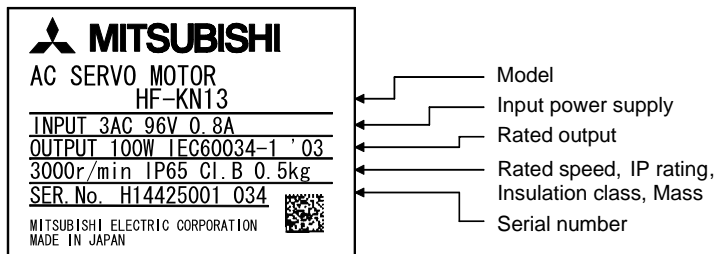

12.1.2. Parts identification

Refer to section 11.1 for details of the cables and connectors.

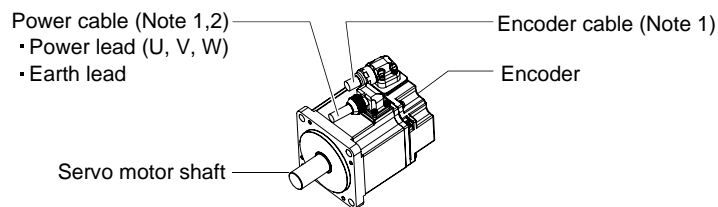

Note 1. The encoder cable and the power supply cable are options.

2. An electromagnetic brake cable is separately required for the servo motor with an electromagnetic brake.

12. SERVO MOTOR

12.1.3 Electromagnetic brake



CAUTION

- The electromagnetic brake is provided for preventing a drop at power failure or at servo alarm occurrence during vertical drive, or for holding a shaft at stop. Do not use it for normal braking (including braking at servo lock).
- The brake has a time lag. Use the brake so that servo motor control is started after the brake has completely opened.
- Configure the electromagnetic brake operation circuit which interlocks with an external emergency stop switch.
- Refer to section 3.11 for details of the circuit configuration and the timing chart.

The servo motor with an electromagnetic brake can be used to prevent a drop in vertical lift applications or to ensure double safety at an emergency stop, for example. When performing servo motor operation, supply power to the electromagnetic brake to release the brake. Switching power off makes the brake effective.

(1) Electromagnetic brake power supply

Prepare the following power supply exclusively used for the electromagnetic brake. The electromagnetic brake terminals (B1, B2) do not have polarity.

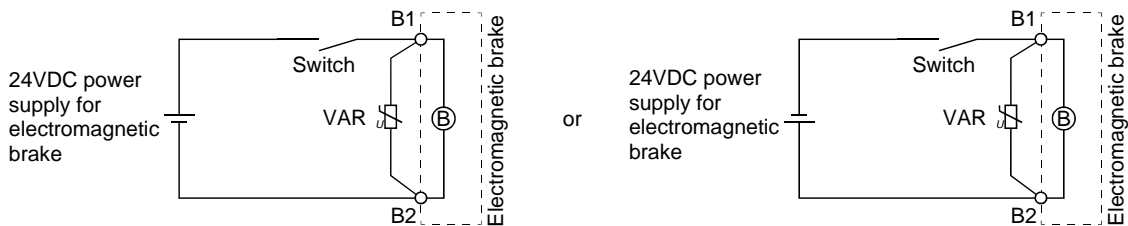

A surge absorber (VAR) must be installed between B1 and B2. Refer to (3) in this section for the selection method of surge absorber, and to "Electromagnetic brake characteristics" in section of each servo motor series for selecting surge absorbers.

(2) Noise generation

Though the brake lining may rattle during operation in the low-speed area, it poses no functional problem. If braking noise occurs, it may be improved by setting the machine resonance suppression filter or adaptive vibration suppression control in the servo amplifier parameters. Refer to section 7.2 for details.

(3) Selection of surge absorbers for electromagnetic brake circuit

(a) Selection condition

Item	Conditions
Electromagnetic brake specification	R[Ω] : Resistance L[H] : Inductance Vb[V] : Power supply voltage
Desired suppressed voltage	Vs[V] or less
Durable surge application time	N times

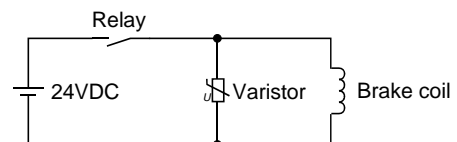

12. SERVO MOTOR

(b) Tentative selection and verification of surge absorber

1) Maximum permissible circuit voltage of varistor

Tentatively select a varistor whose maximum allowable voltage is larger than V_b [V].

2) Brake current (I_b)

$$I_b = \frac{V_b}{R} \text{ [A]}$$

3) Energy (E) generated in the brake coil

$$E = \frac{L \times I_b^2}{2} \text{ [J]}$$

4) Varistor limit voltage (V_i)

From the energy (E) generated in the brake coil and the varistor characteristic diagram, calculate the varistor limit voltage (V_i) when the brake current (I_b) flows into the tentatively selected varistor during opening of the circuit.

V_i is favorable when the varistor limit voltage (V_i)[V] is smaller than the desired suppressed voltage (V_s)[V].

If V_i is not smaller than V_s , reselect a varistor or improve the withstand voltage of devices.

5) Surge current width (τ)

Given that the varistor absorbs all energies, the surge current width (τ) is as follows.

$$\tau = \frac{E}{V_i \times I_b} \text{ [s]}$$

6) Inspection of surge life of varistor

From the varistor characteristic diagram, calculate the guaranteed current value (I_p) in which the number of the surge application life is N at the surge current width (τ). Calculate the ratio (I_p/I_b) of the guaranteed current value (I_p) to the brake current (I_b).

If an enough margin is ensured for I_p/I_b , the number of the surge application life N [Time] can be considered as favorable.

(4) Others

A leakage magnetic flux occurs at the shaft end of the servo motor with an electromagnetic brake. Note that chips, screws and other magnetic substances are attracted.

12. SERVO MOTOR

12.1.4 Servo motor shaft shapes

In addition to the straight shaft, keyway shaft and D cut shaft are available as the servo motor shafts.

The keyway shaft and the D cut shaft cannot be used in frequent start/stop applications. Since we cannot warrant the servo motor against fracture and similar accidents attributable to a loose key, use a friction coupling, etc. when coupling the shaft with a machine.

The shaft shape of the standard servo motor varies depending on the capacity. Refer to sections 12.5.4 and 12.6.4.

The keyway shaft (with single pointed key) is available only with the HF-KP□G7 servo motor.

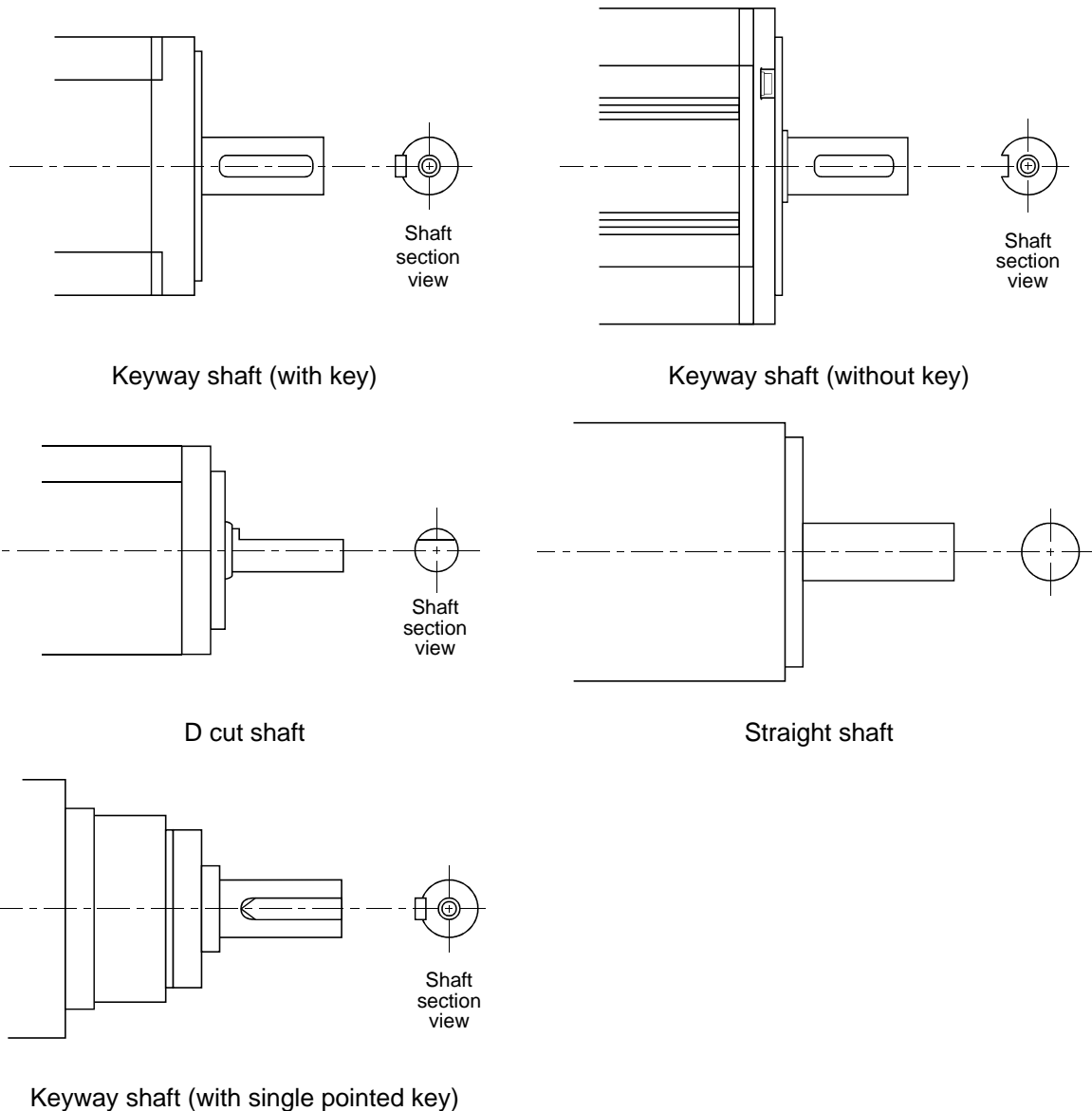

12. SERVO MOTOR

12.2 Installation



WARNING

- Be sure to ground the servo motor to prevent an electric shock.



CAUTION

- Do not stack the product packages exceeding the maximum number specified on the package.
- Install the equipment to incombustibles. Installing it directly or close to combustibles may cause a fire.
- Install the equipment on a weight-bearing place in accordance with this Instruction Manual.
- Do not get on or place heavy objects on the equipment as it may cause injury.
- Use the equipment within the specified environmental condition range. Refer to sections 12.5.2 (1) and 12.6.2 (1).
- Do not drop or shock the servo motor as it is precision equipment.
- Do not install or operate a servo motor which is damaged or has any part missing.
- Do not hold the cable, the shaft or the encoder when carrying the servo motor as it may cause malfunction or injury.
- Install the servo motor with a reduction gear in the specified direction. Improper installation causes oil leakage, leading to a fire and malfunction.
- Couple the servo motor to a machine securely. Insecure coupling may cause the servo motor to come off, resulting in injury.
- Be sure to measure the motor vibration level with the servo motor mounted to the machine when checking the vibration level. A great vibration may cause the early damage of a bearing, encoder, brake, and reduction gear. The great vibration may also cause the poor connector connection or bolt looseness.
- For the gain adjustment at the equipment startup, check the torque waveform and the speed waveform by using a measurement device, and then check that no vibration occurs. If the vibration occurs due to high gain, the vibration may cause the early damage of the servo motor.
- Never hit the shaft end of the servo motor, especially when coupling the servo motor to a machine as it may damage the encoder.
- When coupling a load to the servo motor, do not use a rigid coupling as it may break the shaft.
- Balance the load to the extent possible. Failure to do so can cause vibration during servo motor operation or damage the bearings and the encoder.
- Take safety measures, e.g. provide covers, to prevent accidental access to the rotating parts of the servo motor during operation.
- Do not apply load exceeding the permissible load as it may break the shaft, causing injury.
- When the equipment has been stored for an extended period of time, consult your local sales office.
- When handling the servo motor, be careful with the edged parts such as the corners of the servo motor.

12. SERVO MOTOR

12.2.1 Installation direction

(1) Standard servo motor

The following table indicates the installation direction of the standard servo motor.

Servo motor series	Installation direction	Remarks
HF-KN	Any directions	For installation in the horizontal direction, it is recommended to set the connector section downward.

When installing the servo motor in horizontal direction, it is recommended to set the connector section downward. When installing it vertically or obliquely, provide a cable trap for the cable.

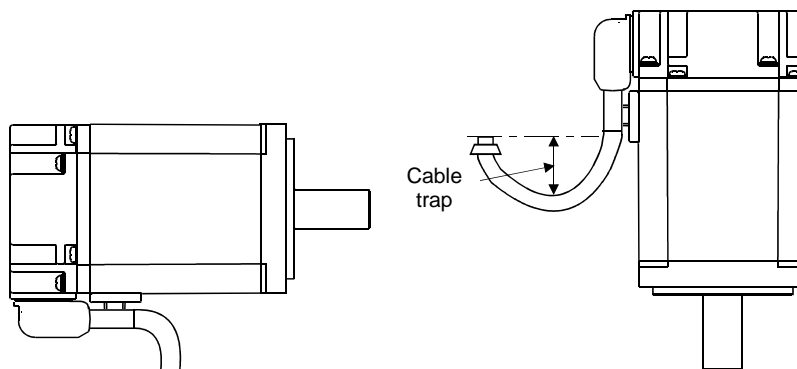

(2) Servo motor with an electromagnetic brake

The servo motor with an electromagnetic brake can also be installed in the same direction as the standard servo motor. When the servo motor with an electromagnetic brake is installed with the shaft upward, the brake plate may generate a sliding sound, but it is not a fault.

(3) Servo motor with a reduction gear (HF-KP□G1/G5/G7)

Installation direction of the servo motor with a reduction gear varies depending on the reduction gear type. Be sure to install it in the specified direction. Refer to section 12.6.4 for details.

12. SERVO MOTOR

12.2.2 Precautions for load remove

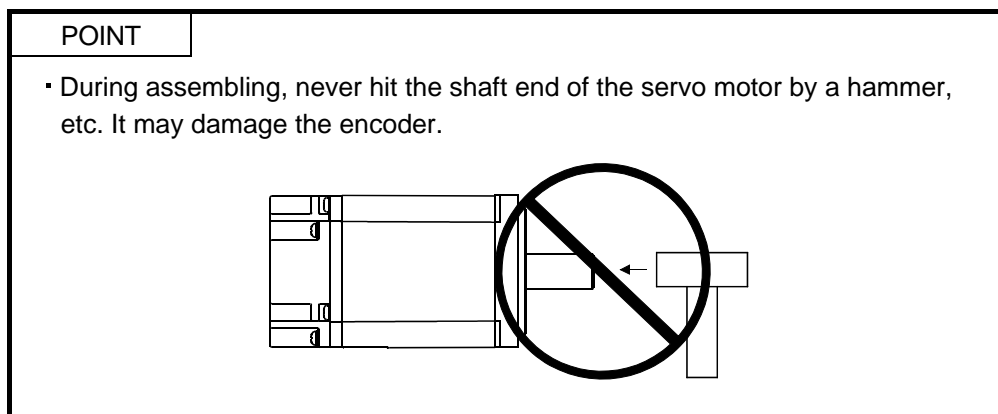

- (1) When mounting a pulley to the servo motor shaft with a keyway, use the screw hole on the shaft end. To fit the pulley, first insert a double-end stud into the screw hole on the shaft, put a washer against the end face of the coupling, and insert and tighten a nut to force the pulley in.

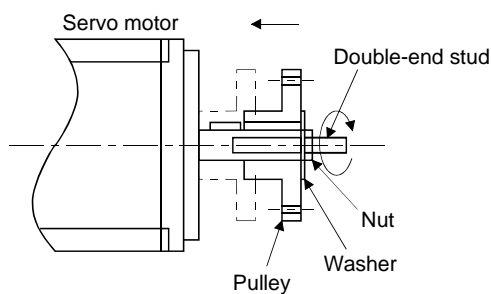

- (2) For the shaft without a keyway, use a friction coupling or the like.
- (3) When removing the pulley, use a pulley remover to protect the shaft from hard load or impact.
- (4) To ensure safety, fit a protective cover or the like on the rotating part, such as the pulley, mounted to the shaft.
- (5) When a threaded shaft end part is needed to mount a pulley on the shaft, please contact your local sales office.
- (6) The direction of the encoder on the servo motor cannot be changed.
- (7) For installation of the servo motor, use spring washers, etc. and fully tighten the bolts so that they do not become loose due to vibration.

12. SERVO MOTOR

12.2.3 Permissible load for the shaft

POINT
▪ Do not use a rigid coupling as it may apply excessive bending load to the shaft, leading to shaft breakage.

For the permissible shaft load specific to the servo motor, refer to sections 12.5.2 (1), 12.6.4 (1) (c), 12.6.4 (2) (c).

- (1) Use a flexible coupling and make sure that the misalignment of the shaft is less than the permissible radial load.
- (2) When using a pulley, sprocket or timing belt, select a diameter that will fit into the permissible radial load.
- (3) Excess of the permissible load can shorten the bearing life and damage the shaft.
- (4) The load indicated in this section is static load in a single direction and does not include eccentric load. Make eccentric load as small as possible. Not doing so may damage the servo motor.

12.2.4 Protection from oil and water

Provide adequate protection to prevent foreign matter such as oil from entering the servo motor shaft. When installing the servo motor, consider the following in this section.

- (1) Do not use the servo motor with its cable soaked in oil or water.

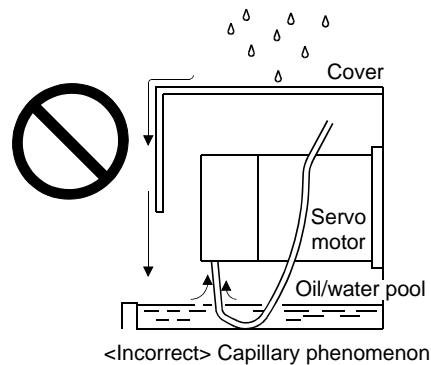

- (2) When the servo motor is installed with the shaft upward, provide measures to prevent the servo motor being exposed to oil or water from a machine side, gear box, etc.

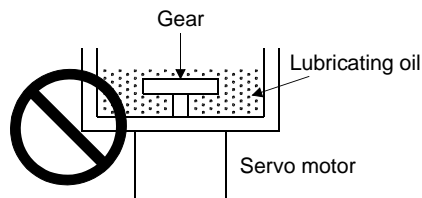

12. SERVO MOTOR

- (3) If the servo motor is exposed to oil such as coolant, the sealant, packing, cable and others may be affected depending on the oil type.
- (4) In the environment where the servo motor is exposed to oil mist, oil, water and/or grease, a standard specification servo motor may not be usable. Contact your local sales office for more details.

12.2.5 Cable

The power supply and encoder cables routed from the servo motor should be fixed to the servo motor to keep them unmovable. Otherwise, the cables may break. In addition, do not modify the connectors on the cable ends.

12.2.6 Inspection



WARNING

- Before wiring, be sure to turn off the power, wait for 15 minutes or longer, and then make sure that the charge lamp is off to prevent an electric shock. In addition, always confirm if the charge lamp is off or not from the front of the servo amplifier.
- Due to a risk of an electric shock, only qualified personnel should attempt inspection. For repair and parts replacement, contact your local sales office.

POINT

- Do not disassemble and/or repair the equipment.

It is recommended to make the following checks periodically.

- (a) Check the bearings, the brake section, etc. for unusual noise.
- (b) Check the cables and the like for scratches and cracks. Especially when the junction cable is movable, perform periodic inspection according to operating conditions.
- (c) Check the servo motor shaft and coupling for misalignment.
- (d) Check the power supply connector, brake connector, and encoder connector tightening screws for looseness.

12. SERVO MOTOR

12.2.7 Life

Service lives of the following parts are listed below. However, the service lives vary depending on operating methods and environmental conditions. If any fault is found in the parts, they must be replaced immediately regardless of their service life. For parts replacement, please contact your local sales office.

Part name	Life guideline	Remarks
Bearing	20,000 to 30,000 hours	The Life guideline field gives the reference time. If any fault is found before this time is reached, the part must be changed.
Encoder	20,000 to 30,000 hours	

When the servo motor is operated at the rated speed under the rated load, replace the bearings in 20,000 to 30,000 hours as a guideline. However, this service life varies depending on the operating conditions. The bearings must be replaced if unusual noise or vibration is found during inspection.

12.2.8 Machine accuracies

The following table indicates the machine accuracies of the servo motor around the output shaft and mounting (except the special purpose products).

Accuracy [mm]	Measuring position	Flange size
		Less than □100
Runout of flange surface about output shaft	a)	0.05
Runout of fitting outer diameter of flange surface	b)	0.04
Runout of output shaft end	c)	0.02

Reference diagram

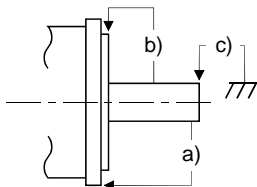

12. SERVO MOTOR

12.3 Connectors used for servo motor wiring

POINT
<ul style="list-style-type: none"> The IP rating indicated for connectors indicates the dust and water proofing levels when the connectors are installed to a servo amplifier or servo motor. If the IP rating of the connector and the servo amplifier/servo motor differs, the overall IP rating depends on the lowest of all.

12.3.1 Selection of connectors

Use the connector configuration products given in the table as the connectors for connection with the servo motor. Refer to section 12.3.2 for the compatible connector configuration products.

HF-KN series • HF-KP□G1/G5/G7

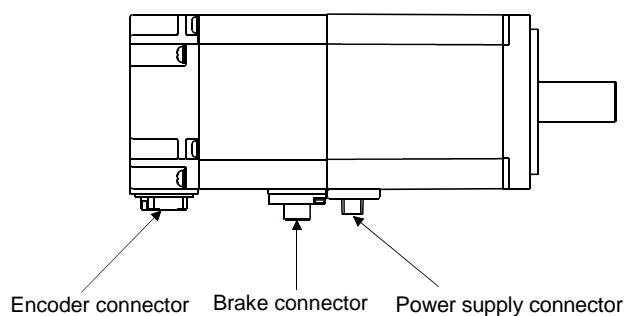

Servo motor	Wiring connector		
	For encoder	For power supply	For brake
HF-KN(B) • HF-KP(B)G1/G5/G7	Connector configuration A	Connector configuration B	Connector configuration C

12. SERVO MOTOR

12.3.2 Wiring connectors (Connector configurations A B C)

These connectors comply with the EN and UL/CSA standards.

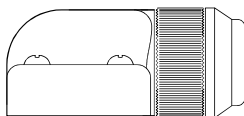

Connector configuration	Configuration product		Servo motor encoder connector
	Connector (IP rating: IP65)	Crimping tool	
A	Connector: 1674320-1 (Tyco Electronics)	For Ground clip: 1596970-1 For REC. contact: 1596847 (Tyco Electronics)	1674339-1 (Tyco Electronics)

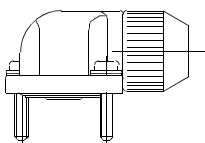

Connector configuration	Configuration product		Servo motor power supply connector
	Connector (IP rating: IP65)	Crimping tool	
B	Connector: JN4FT04SJ1-R Hood, socket insulator, bushing, ground nut Contact: ST-TMH-S-C1B-100-(A534G) (JAE)	CT160-3-TMH5B (JAE)	JN4AT04NJ1 (JAE)

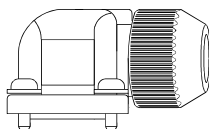

Connector configuration	Configuration product		Servo motor brake connector
	Connector (IP rating: IP65)	Crimping tool	
C	Connector: JN4FT02SJ1-R Hood, socket insulator, bushing, ground nut Contact: ST-TMH-S-C1B-100-(A534G) (JAE)	CT160-3-TMH5B (JAE)	JN4AT02PJ1 (JAE)

12. SERVO MOTOR

12.4 Connector outline drawings

The connector outline drawings for wiring the servo motor are shown below.

(1) Tyco Electronics 1674320-1

[Unit: mm]

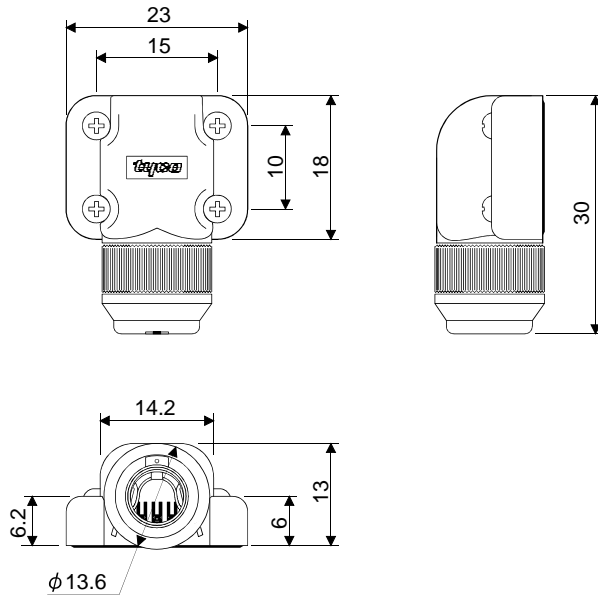

Crimping tool: 1596970-1 (For ground clip)
1596847 (For receptacle contact)

(2) JAE JN4FT02SJ1-R

[Unit: mm]

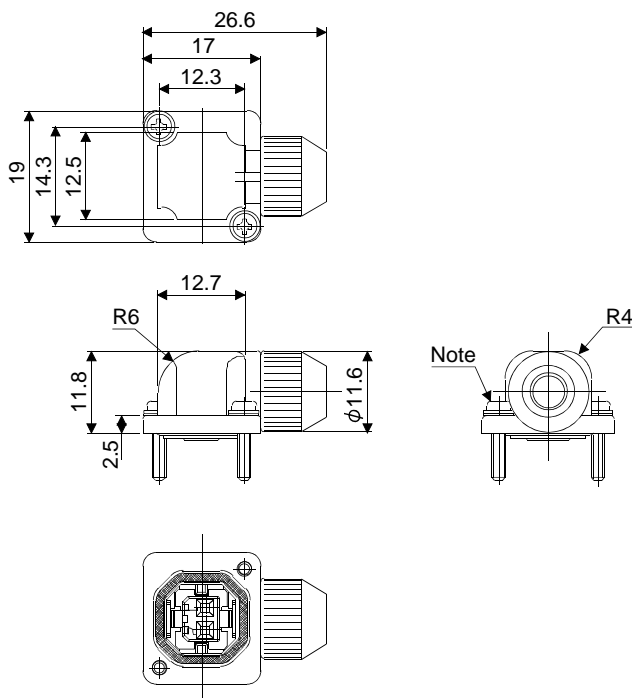

Note. The recommended screw tightening torque is 0.2N · m.

Crimping tool: CT160-3-TMH5B

12. SERVO MOTOR

JN4FT04SJ1-R

[Unit: mm]

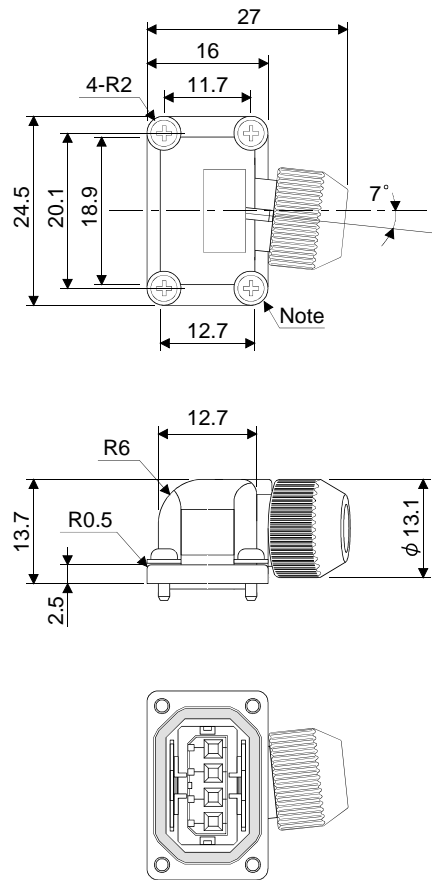

Note. The recommended screw tightening torque is 0.2N · m.

Crimping tool: CT160-3-TMH5B

12. SERVO MOTOR

12.5 HF-KN series servo motor

This section provides information on the servo motor specifications and characteristics. When using the HF-KN series servo motor, always read the Safety Instructions in the beginning of this manual and sections 12.1 to 12.4, in addition to this section.

12.5.1 Model definition

The following describes what each block of a model name indicates. Note that not all the combinations of the symbols exist.

HF - KN □ 3 □ □

Series name

Shaft type

Symbol	Shaft shape	HF-KN□
None	Standard (Straight shaft)	053 to 43
K	With keyway (With key)	23 · 43
D	D cut shaft	053 · 13

Electromagnetic brake

Symbol	Electromagnetic brake
None	None
B	With

Rated speed
3000 [r/min]

Rated output

Symbol	Rated output [W]
05	50
1	100
2	200
4	400

Appearance

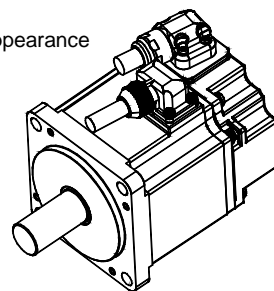

12. SERVO MOTOR

12.5.2 Standard specifications

(1) Standard specifications

Item			Servo motor				
			HF-KN series (Low inertia, small capacity)				
			053	13	23	43	
Applicable servo amplifier	MR-JN-□A		10		20	40	
	MR-JN-□A1		10		20		
Continuous running duty (Note 1)	Rated output [kW]		0.05	0.1	0.2	0.4	
	Rated torque	[N · m]	0.16	0.32	0.64	1.3	
		[oz · in]	22.7	45.3	90.6	184	
Rated speed (Note 1)		[r/min]	3000				
Maximum speed		[r/min]	4500				
Instantaneous permissible speed		[r/min]	5175				
Maximum torque			[N · m]	0.48	0.95	1.9	3.8
			[oz · in]	68.0	135	269	538
Power rate at continuous rated torque		[kW/s]	4.87	11.5	16.9	38.6	
Inertia moment (Note 3)	J [$\times 10^{-4}$ kg · m ²]		0.052	0.088	0.24	0.42	
	WK ² [oz · in ²]		0.284	0.481	1.31	2.30	
Recommended load to motor inertia moment ratio (Note 2)			15 times or less		24 times or less	22 times or less	
Power supply capacity			Refer to section 10.2.				
Rated current		[A]	0.9	0.8	1.4	2.7	
Maximum current		[A]	2.7	2.4	4.2	8.1	
Speed/position encoder			Incremental 17 bits encoder (Resolution per servo motor 1 rotation: 131072pulse/rev)				
Accessory							
Insulation class			Class B				
Structure			Totally-enclosed, self-cooled (IP rating: IP65 (Note 4))				
Environmental conditions (Note 5)	Ambient temperature	In operation	0°C to +40°C (32°F to 104°F) (non-freezing)				
		In storage	-15°C to +70°C (5°F to 158°F) (non-freezing)				
	Ambient humidity	In operation	80%RH or less (non-condensing)				
		In storage	90%RH or less (non-condensing)				
	Ambience		Indoors (no direct sunlight) Free from corrosive gas, flammable gas, oil mist, dust and dirt				
	Altitude		Max. 1000m above sea level				
Vibration (Note 6)		X, Y : 49m/s ²					
Vibration rank (Note 7)			V-10				
Permissible load to the shaft (Note 8)	L	[mm]	25		30		
		Radial	[N]	88		245	
			[lb]	19.8		55.1	
	Thrust	[N]	59		98		
		[lb]	13.3		22.0		
Mass (Note 3)		[kg]	0.4	0.5	1.0	1.4	
		[lb]	0.88	1.10	2.21	3.09	

Note 1. When the power supply voltage drops, the output and the rated speed cannot be guaranteed.

2. If the load to motor inertia moment ratio exceeds the indicated value, please contact your local sales office.

3. Refer to the outline drawings for the servo motors with an electromagnetic brake.

4. Except for the shaft-through portion.

5. In the environment where the servo motor is exposed to oil mist, oil and/or water, a standard specification servo motor may not be usable. Contact your local sales office.

12. SERVO MOTOR

6. The vibration direction is as shown in the figure. The value is the one at the part that indicates the maximum value (normally the opposite-to-load side bracket). When the servo motor stops, fretting is likely to occur at the bearing. Therefore, suppress the vibration to about half of the permissible value.

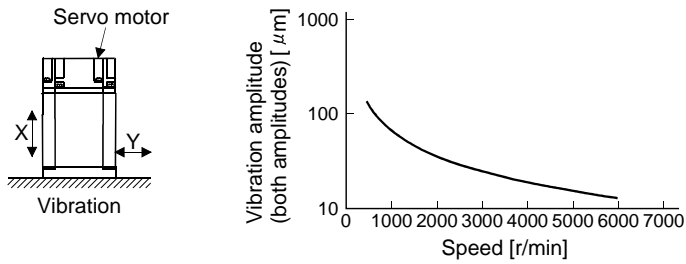

7. V-10 indicates that the amplitude of a single servo motor is $10\mu\text{m}$ or less. The following figure shows the servo motor installation position for measurement and the measuring position.

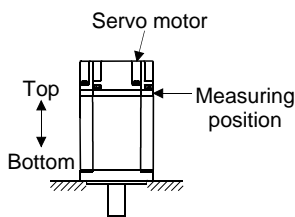

8. For the symbols in the table, refer to the following diagram. Do not subject the shaft to load greater than these values in the table. These values are applicable when the loads are applied independently.

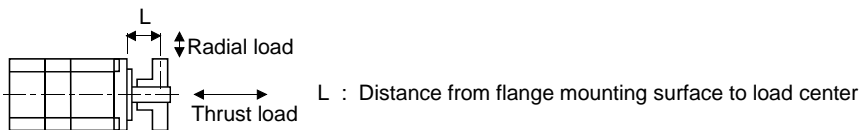

(2) Torque characteristics

POINT
<ul style="list-style-type: none"> It is recommended to use the machine which generates unbalanced torque, e.g. a vertical lift application, so that the unbalanced torque is not more than 70% of the rated torque.

When the input power supply specifications of the servo amplifier are 1-phase 230VAC, the torque characteristics are indicated by heavy lines. Part of the torque characteristics are indicated by broken lines for the 1-phase 100VAC power supply and by thin lines for the 1-phase 200VAC power supply.

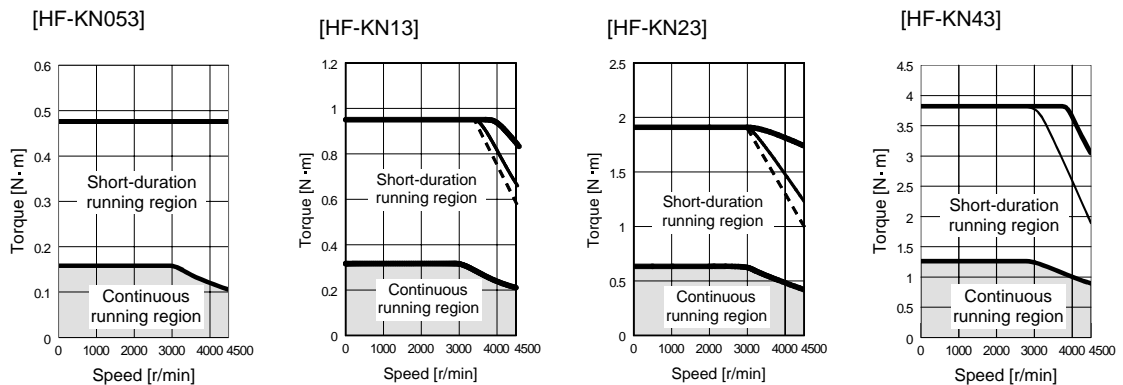

12. SERVO MOTOR

12.5.3 Electromagnetic brake characteristics



CAUTION

- The electromagnetic brake is provided for preventing a drop at power failure or at servo alarm occurrence during vertical drive, or for holding a shaft at stop. Do not use it for normal braking (including braking at servo lock).
- Before performing the operation, be sure to confirm that the electromagnetic brake operates properly.

The characteristics of the electromagnetic brake provided for the servo motor with an electromagnetic brake are indicated below.

Item		Servo motor	HF-KN series			
			053B	13B	23B	43B
Type (Note 1)		Spring-loaded safety brake				
Rated voltage (Note 4)		24VDC ⁰ _{-10%}				
Power consumption [W]at20°C		6.3		7.9		
Coil resistance (Note 6) [Ω]		91.0		73.0		
Inductance (Note 6) [H]		0.088		0.10		
Brake static friction torque		[N · m]	0.32		1.3	
		[oz · in]	45.3		184	
Release delay time (Note 2) [s]		0.03		0.03		
Braking delay time (Note 2) [s]		DC off	0.01		0.02	
Permissible braking work		Per braking [J]	5.6		22	
		Per hour [J]	56		220	
Brake looseness at servo motor shaft (Note 5) [degrees]		2.5		1.2		
Brake life (Note 3)		Number of braking cycles [times]	20000		20000	
		Work per braking [J]	5.6		22	
Selection example of surge absorbers to be used (Note 7, 8)		For the suppressed voltage 125V	TND20V-680KB			
		For the suppressed voltage 350V	TND10V-221KB			

Note 1. There is no manual release mechanism. Use a 24VDC power supply to release the brake electrically.

2. The value for initial ON gap at 20°C (68°F).

3. Brake gap increases as the brake lining wears, but the gap is not adjustable. Therefore, the brake life is indicated as the number of braking cycles available before the gap adjustment is required.

4. Always prepare the power supply exclusively used for the electromagnetic brake.

5. The above values are typical initial values and not guaranteed values.

6. These values are measured values and not guaranteed values.

7. Select the electromagnetic brake control relay properly, considering the characteristics of the electromagnetic brake and surge absorber.

8. Manufactured by Nippon Chemi-Con Corporation.

12. SERVO MOTOR

12.5.4 Servo motors with special shafts

The servo motors with special shafts indicated by the symbols (K and D) in the table are available. K and D are the symbols attached to the servo motor model names.

Servo motor	Shaft shape	
	Keyway shaft (with key)	D cut shaft
HF-KN053 • 13□		D
HF-KN23 • 43□	K	

(1) Keyway shaft (with key)

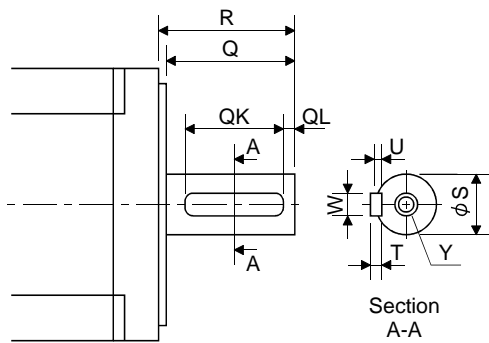

Variable dimension table

[Unit: mm]

Servo motor	Variable dimensions								
	S	R	Q	W	QK	QL	U	T	Y
HF-KN23K • 43K	14h6	30	27	5	20	3	3	5	M4 Depth 15

(2) D cut shaft

[Unit: mm]

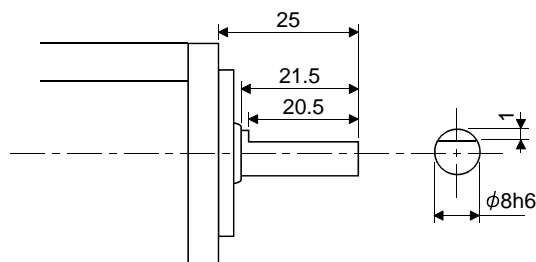

12. SERVO MOTOR

12.5.5 Connector installation

If the connector is not fixed securely, it may come off or may not produce a splash-proof effect during operation. To achieve the IP rating of IP65, pay attention to the following points and install the connectors.

(1) When screwing the connector, hold the connector still and gradually tighten the screws in a crisscross pattern.

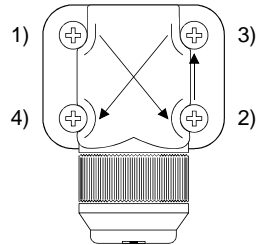

Tightening sequence
1) → 2) → 3) → 4)

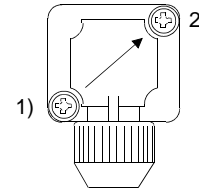

Tightening sequence
1) → 2)

For power supply and encoder connectors

For brake connector

(2) Tighten the screws evenly. Tightening torques are as indicated below.

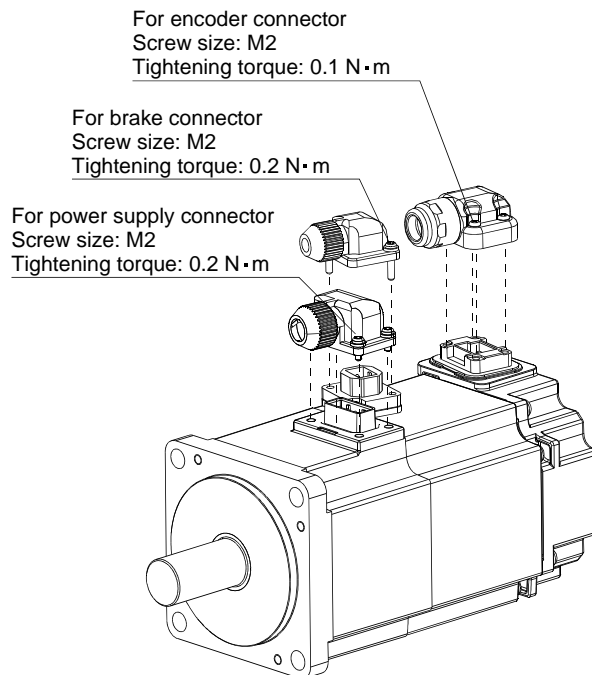

(3) The servo motor fitting part of each connector is provided with a splash-proof seal (O ring). When installing the connector, take care to prevent the seal (O ring) from dropping and being pinched. If the seal (O ring) has dropped or is pinched, a splash-proof effect is not produced.

12. SERVO MOTOR

12.5.6 Outline drawings

The actual dimensions may be 1 to 3mm larger than the drawing dimensions. Design the machine side with allowances.

When running the cables to the load side, take care to avoid interference with the machine. The dimensions in the drawings without tolerances are the reference dimensions.

The inertia moments in the table are the value calculated by converting the total value of inertia moment for servo motor and electromagnetic brake to the servo motor shaft.

(1) Standard (without an electromagnetic brake)

Model	Output [W]	Inertia moment $J [\times 10^{-4} \text{kg} \cdot \text{m}^2] (\text{WK}^2 [\text{oz} \cdot \text{in}^2])$	Mass [kg] ([lb])
HF-KN053	50	0.052 (0.284)	0.4 (0.882)

[Unit: mm]

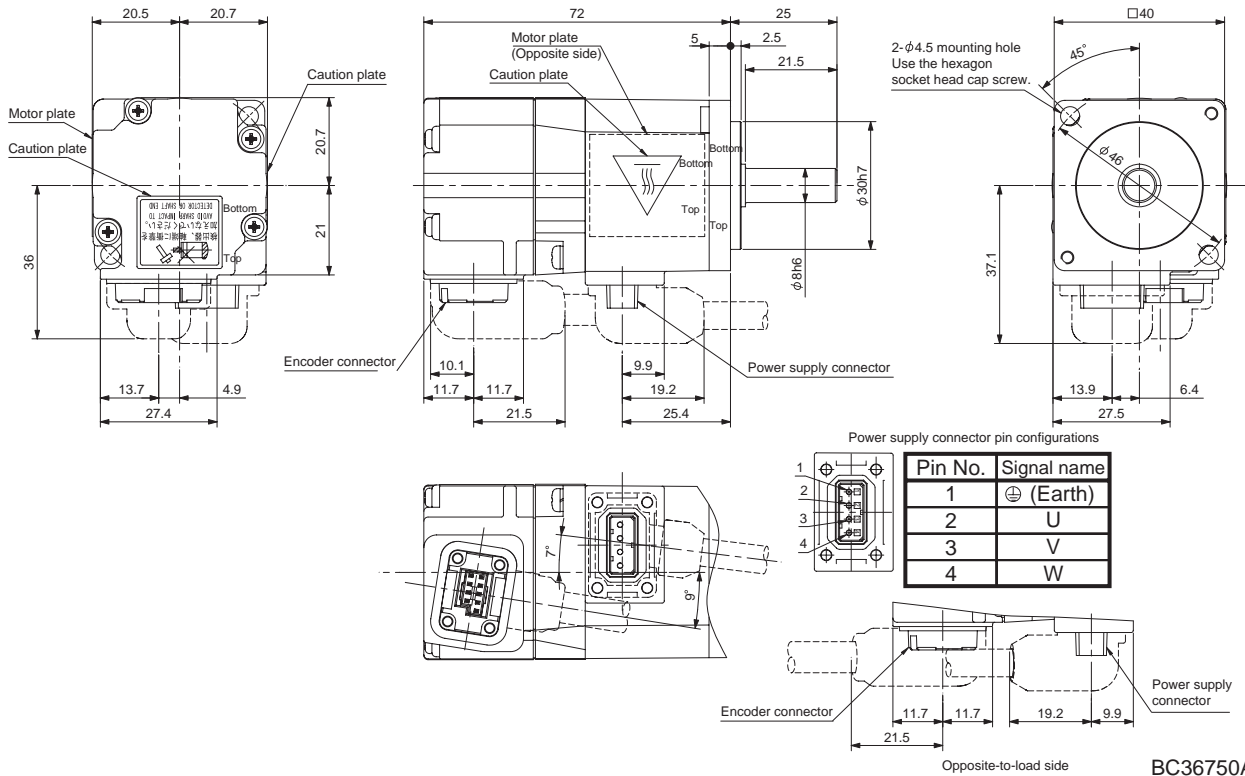

BC36750A

12. SERVO MOTOR

Model	Output [W]	Inertia moment	
		J [$\times 10^{-4} \text{kg} \cdot \text{m}^2$] (WK^2 [oz · in ²])	Mass [kg] ([lb])
HF-KN13	100	0.088 (0.481)	0.5 (1.10)

[Unit: mm]

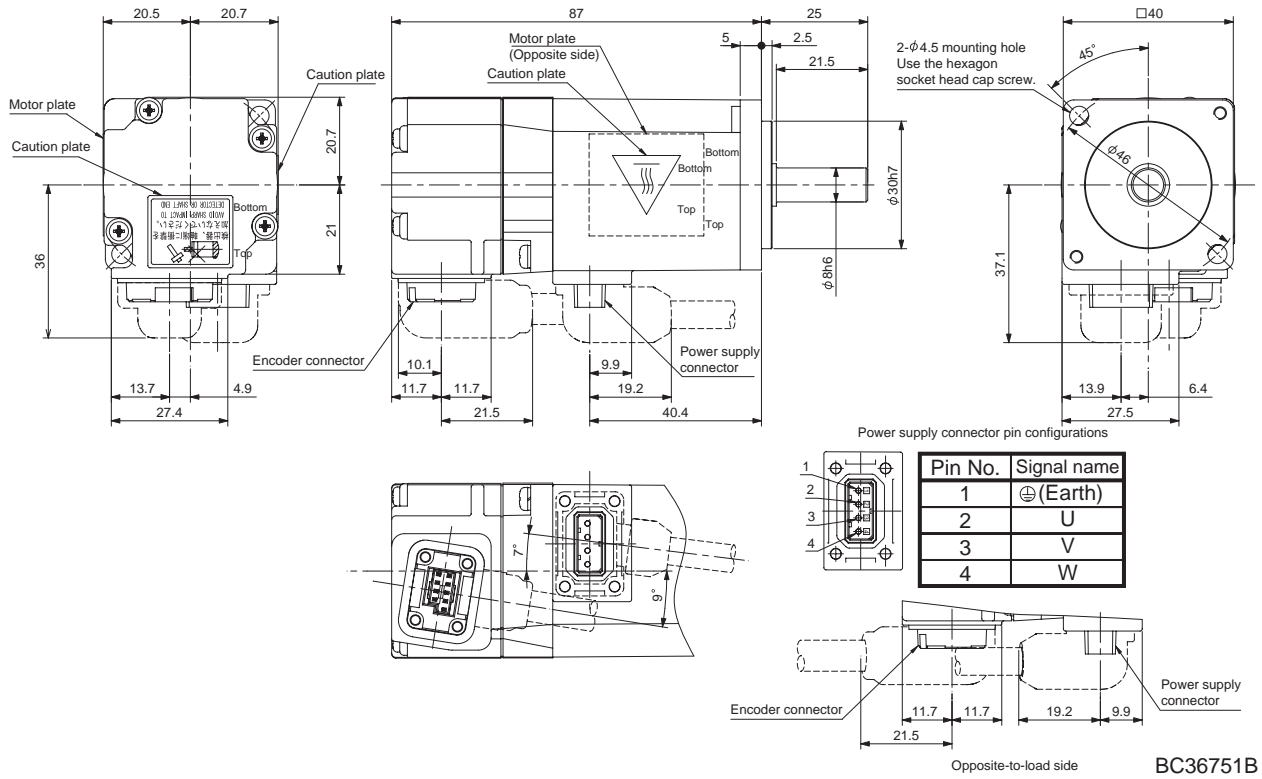

Model	Output [W]	Inertia moment	
		J [$\times 10^{-4} \text{kg} \cdot \text{m}^2$] (WK^2 [oz · in ²])	Mass [kg] ([lb])
HF-KN23	200	0.24 (1.31)	1.0 (2.21)

[Unit: mm]

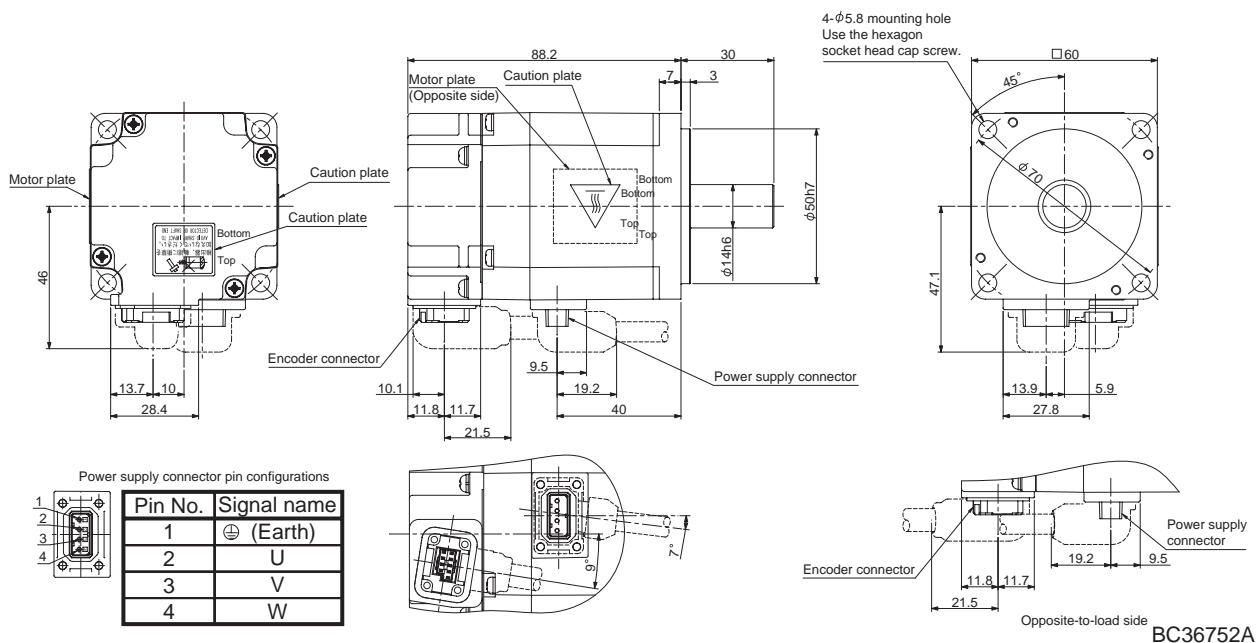

12. SERVO MOTOR

Model	Output [W]	Inertia moment		Mass [kg] (lb)
		$J [\times 10^{-4} \text{kg} \cdot \text{m}^2]$	$(WK^2 [\text{oz} \cdot \text{in}^2])$	
HF-KN43	400	0.42	(2.30)	1.4 (3.09)

[Unit: mm]

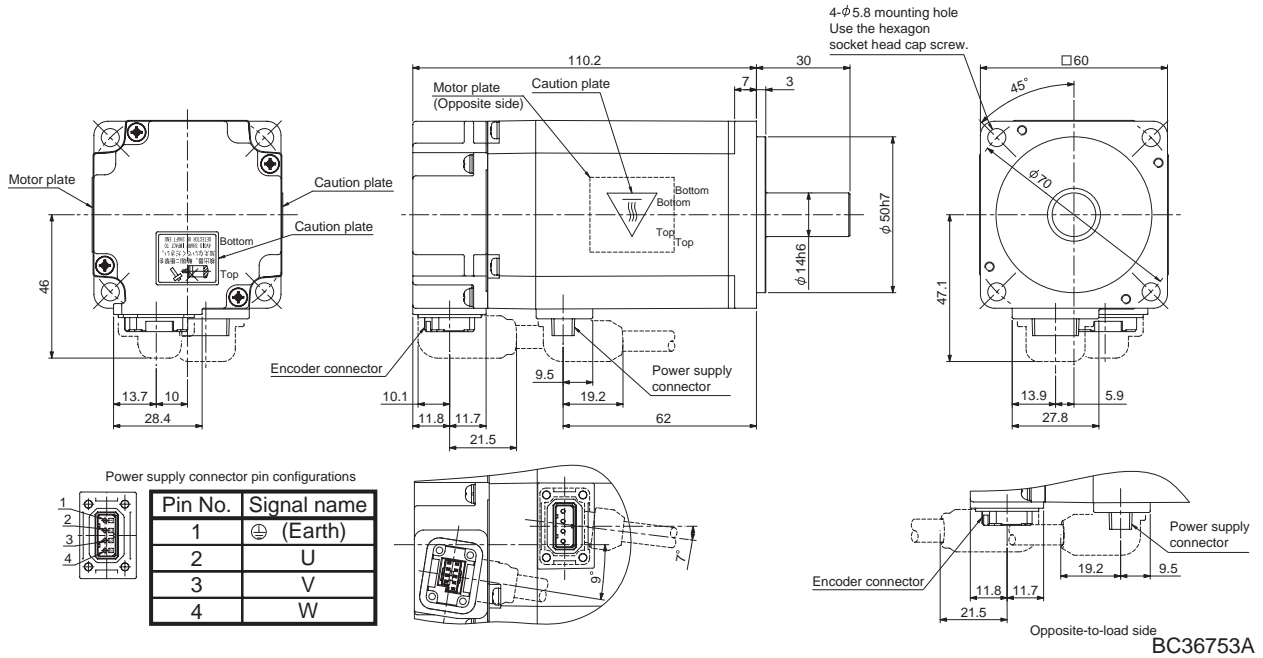

(2) With an electromagnetic brake

Model	Output [W]	Brake static friction torque [N · m]	Inertia moment		Mass [kg] (lb)
			$J [\times 10^{-4} \text{kg} \cdot \text{m}^2]$	$(WK^2 [\text{oz} \cdot \text{in}^2])$	
HF-KN053B	50	0.32	0.054	(0.295)	0.6 (1.32)

[Unit: mm]

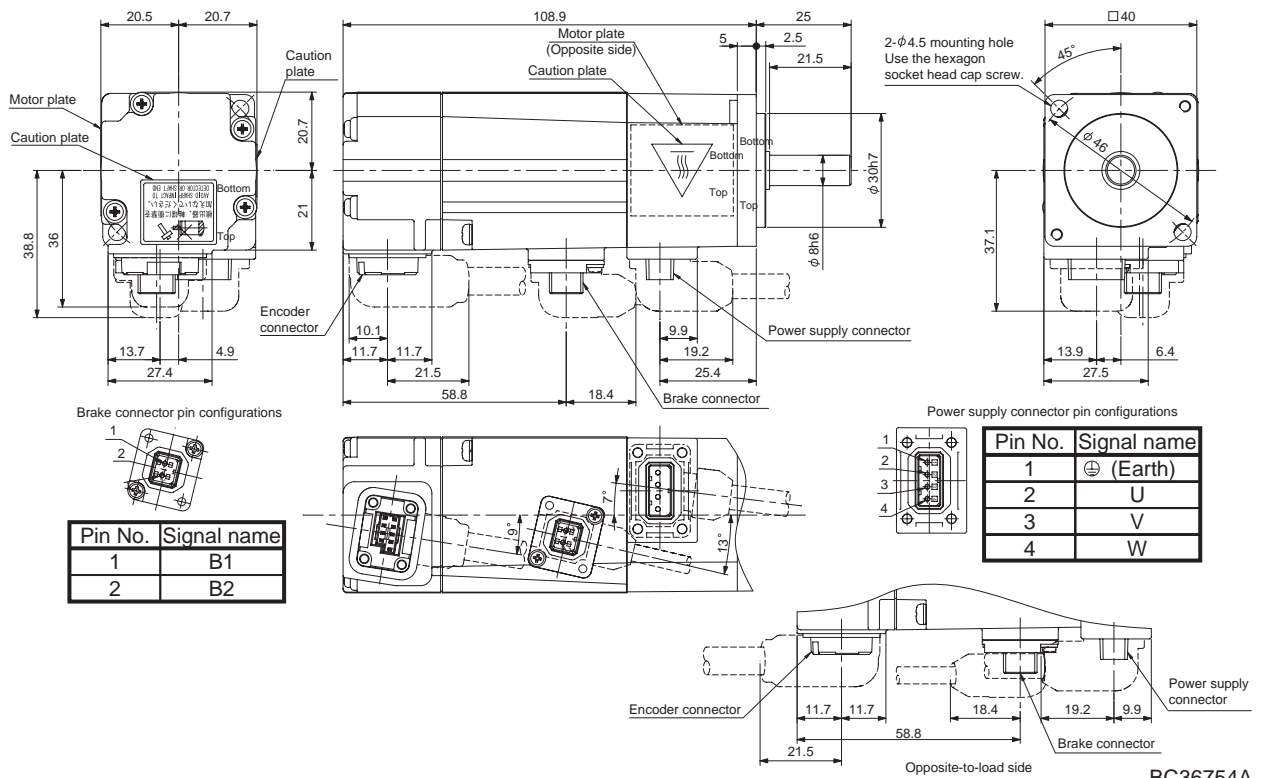

12. SERVO MOTOR

Model	Output [W]	Brake static friction torque [N · m] ([oz · in])	Inertia moment J [$\times 10^{-4}$ kg · m ²] (WK ² [oz · in ²])	Mass [kg] ([lb])
HF-KN13B	100	0.32 (45.3)	0.09 (0.492)	0.7 (1.54)

[Unit: mm]

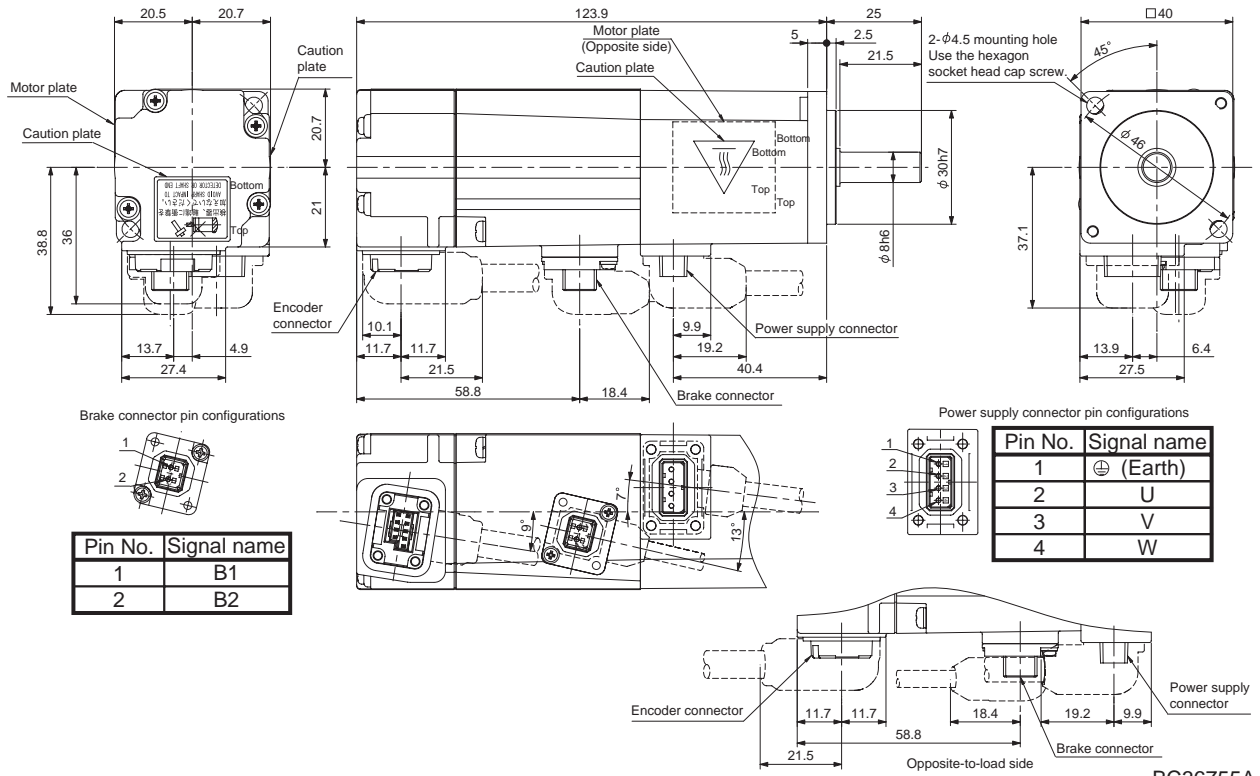

BC36755A

12. SERVO MOTOR

Model	Output [W]	Brake static friction torque [N · m] ([oz · in])	Inertia moment J [$\times 10^{-4}$ kg · m ²] (WK ² [oz · in ²])	Mass [kg] ([lb])
HF-KN23B	200	1.3 (184)	0.31 (1.70)	1.4 (3.09)

[Unit: mm]

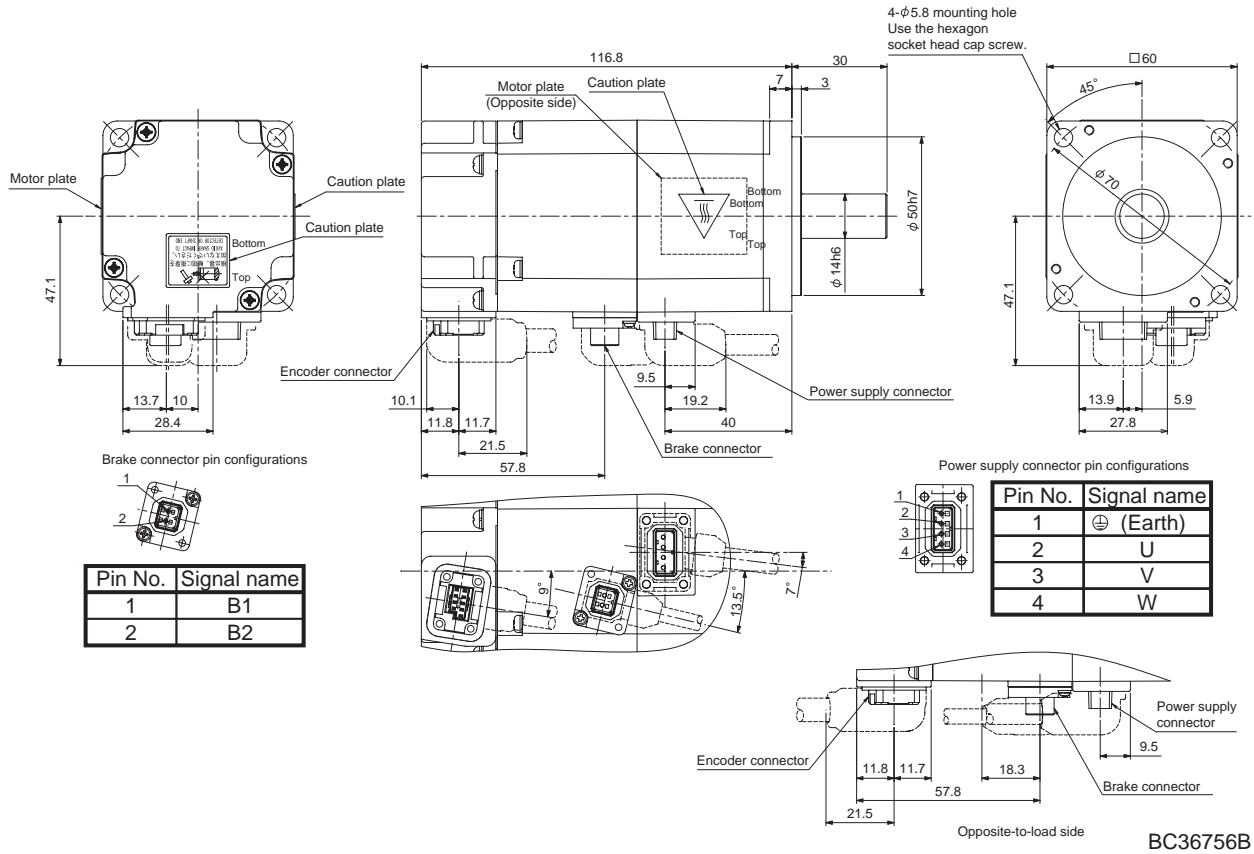

12. SERVO MOTOR

Model	Output [W]	Brake static friction torque [N · m] ((oz · in))	Inertia moment J [$\times 10^{-4}$ kg · m ²] (WK ² [oz · in ²])	Mass [kg] ((lb))
HF-KN43B	400	1.3 (184)	0.50 (2.73)	1.8 (3.97)

[Unit: mm]

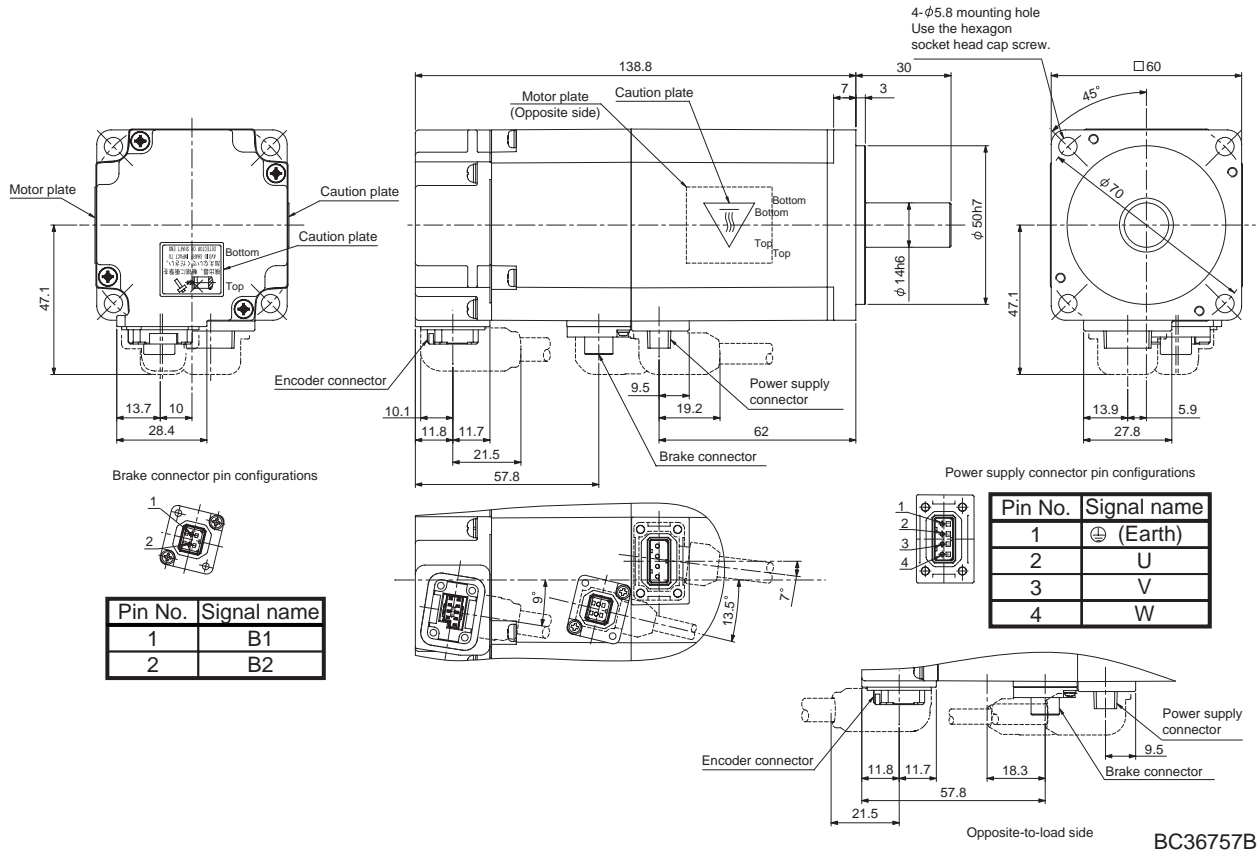

12. SERVO MOTOR

12.6 HF-KP series servo motor

POINT	<ul style="list-style-type: none"> For the outline drawings of the HF-KP□G1/G5/G7servo motor, refer to sections 6.8.3 to 6.8.8 in the Servo Motor INSTRUCTION MANUAL (Vol.2).
-------	--

This section provides information on the servo motor specifications and characteristics. When using the HF-KP series servo motor, always read the Safety Instructions in the beginning of this manual and sections 12.1 to 12.4, in addition to this section.

12.6.1 Model definition

The following describes what each block of a model name indicates. Note that not all the combinations of the symbols exist.

HF - KP □ 3 □ □ □

Series name

Shaft type

Symbol	Shaft shape	HF-KP □
None	Standard (Straight shaft)	053 to 43
K	With keyway (With key)	23 · 43

Reduction gear

Symbol	Reduction gear
G1	For general industrial machine
G5	Flange-mounting flange output type for precision application
G7	Flange-mounting shaft output type for precision application

Electromagnetic brake

Symbol	Electromagnetic brake
None	None
B	With

Rated speed
3000 [r/min]

Rated output

Symbol	Rated output [W]
05	50
1	100
2	200
4	400

Appearance

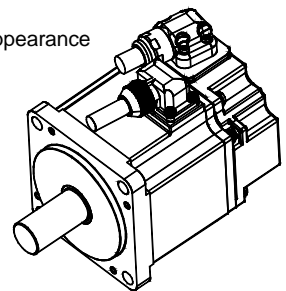

12. SERVO MOTOR

12.6.2 Specifications

(1) Specifications list

Servo motor			HF-KP series (Low inertia, small capacity)			
			053G1/G5/G7	13G1/G5/G7	23G1/G5/G7	43G1/G5/G7
Applicable servo amplifier	MR-JN-□A		10		20	40
	MR-JN-□A1		10		20	
Continuous running duty (Note 1)	Rated output [kW]		0.05	0.1	0.2	0.4
	Rated torque (Note 10)	[N · m]	0.16	0.32	0.64	1.3
		[oz · in]	22.7	45.3	90.6	184
Rated speed (Note 1, 3) [r/min]			3000			
Maximum speed (Note 3) [r/min]			4500 (Note 9)			
Instantaneous permissible speed [r/min]			Refer to section 12.6.4.			
Maximum torque (Note 10)	[N · m]		0.48	0.95	1.9	3.8
	[oz · in]		68.0	135	269	538
Power rate at continuous rated torque (Note 10) [kW/s]			4.87	11.5	16.9	38.6
Inertia moment	J [×10 ⁻⁴ kg · m ²]		Refer to sections 6.8.3 to 6.8.8 in the Servo Motor INSTRUCTION MANUAL (Vol.2).			
	WK ² [oz · in ²]					
Recommended load to motor inertia moment ratio (Note 2)			15 times or less	24 times or less	22 times or less	
Power supply capacity			Refer to section 10.2.			
Rated current [A]			0.9	0.8	1.4	2.7
Maximum current [A]			2.7	2.4	4.2	8.1
Speed/position encoder			18 bits encoder common to absolute position and incremental (Resolution per servo motor 1 rotation: 262144pulse/rev) (Note 8)			
Accessory						
Insulation class			Class B			
Structure			Totally-enclosed, self-cooled (IP rating: IP44 (Note 4))			
Environmental conditions (Note 5)	Ambient temperature	In operation	0°C to +40°C (32°F to 104°F) (non-freezing)			
		In storage	-15°C to +70°C (5°F to 158°F) (non-freezing)			
	Ambient humidity	In operation	80%RH or less (non-condensing)			
		In storage	90%RH or less (non-condensing)			
	Ambient		Indoors (no direct sunlight) Free from corrosive gas, flammable gas, oil mist, dust and dirt			
	Altitude		Max. 1000m above sea level			
Vibration (Note 6)		X, Y : 49m/s ²				
Vibration rank (Note 7)			V-10			
Permissible load for the shaft			Refer to section 12.6.4.			
Mass [kg] ([lb])			Refer to sections 6.8.3 to 6.8.8 in the Servo Motor INSTRUCTION MANUAL (Vol.2).			

Note 1. When the power supply voltage drops, the output and the rated speed cannot be guaranteed.

2. If the load to motor inertia moment ratio exceeds the indicated value, please contact your local sales office.

3. The above values are in the reduction gear input shaft.

4. Except for the shaft-through portion.

5. In the environment where the servo motor is exposed to oil mist, oil and/or water, a standard specification servo motor may not be usable. Contact your local sales office.

12. SERVO MOTOR

6. For the single servo motor. The vibration direction is as shown in the figure. The value is the one at the part that indicates the maximum value (normally the opposite-to-load side bracket). When the servo motor stops, fretting is likely to occur at the bearing. Therefore, suppress the vibration to about half of the permissible value. Note that this does not apply to the servo motor with a reduction gear.

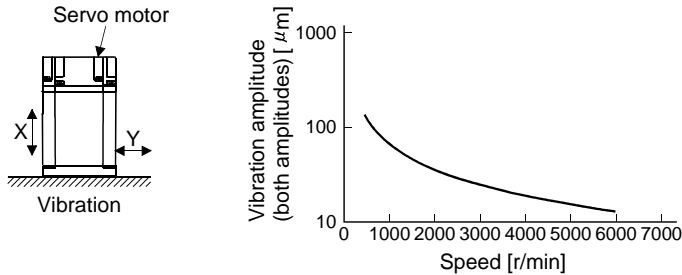

7. V-10 indicates that the amplitude of a single servo motor is 10μm or less. The following figure shows the servo motor installation position for measurement and the measuring position.

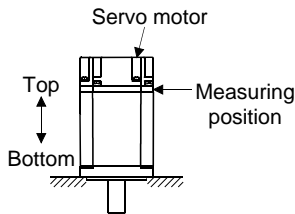

- 8. When combined with the MR-JN series servo amplifier, the resolution performance becomes equivalent to an incremental 17 bits encoder.
- 9. When combining with the MR-JN series servo amplifier.
- 10. For the single servo motor.

(2) Torque characteristics

POINT	<ul style="list-style-type: none"> ▪ It is recommended to use the machine which generates unbalanced torque, e.g. a vertical lift application, so that the unbalanced torque is not more than 70% of the rated torque.
--------------	---

The torque characteristics shown in the following graph are for the servo motor itself. When the input power supply specifications of the servo amplifier are 1-phase 230VAC, the torque characteristics are indicated by heavy lines. Part of the torque characteristics are indicated by broken lines for the 1-phase 100VAC power supply and by thin lines for the 1-phase 200VAC power supply.

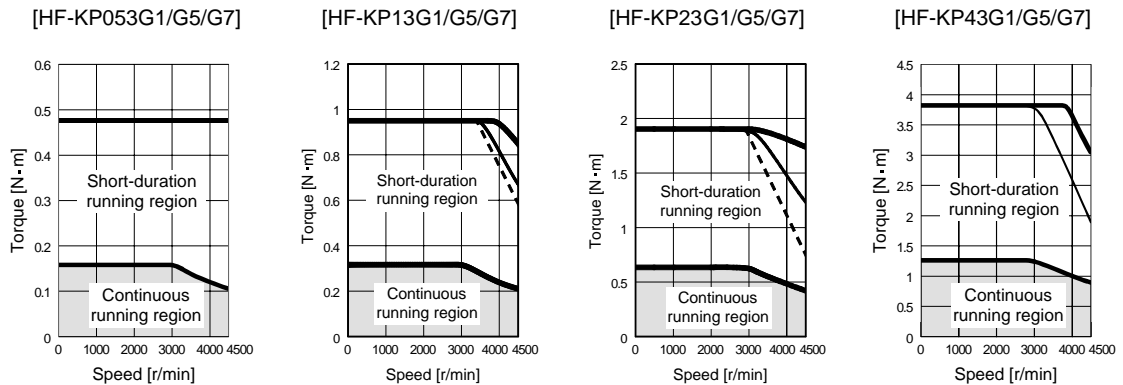

12. SERVO MOTOR

12.6.3 Electromagnetic brake characteristics



CAUTION

- The electromagnetic brake is provided for preventing a drop at power failure or at servo alarm occurrence during vertical drive, or for holding a shaft at stop. Do not use it for normal braking (including braking at servo lock).
- Before performing the operation, be sure to confirm that the electromagnetic brake operates properly.

The characteristics of the electromagnetic brake provided for the servo motor with an electromagnetic brake are indicated below.

Item		Servo motor	HF-KP series			
			053B	13B	23B	43B
Type (Note 1)		Spring-loaded safety brake				
Rated voltage (Note 4)		24VDC ⁰ _{C-10%}				
Power consumption [W]at20°C		6.3		7.9		
Coil resistance (Note 6) [Ω]		91.0		73.0		
Inductance (Note 6) [H]		0.088		0.10		
Brake static friction torque		[N · m]	0.32		1.3	
		[oz · in]	45.3		184	
Release delay time (Note 2) [s]		0.03		0.03		
Braking delay time (Note 2) [s]		DC off	0.01		0.02	
Permissible braking work		Per braking [J]	5.6		22	
		Per hour [J]	56		220	
Brake looseness at servo motor shaft (Note 5) [degrees]		2.5		1.2		
Brake life (Note 3)		Number of braking cycles [times]	20000		20000	
		Work per braking [J]	5.6		22	
Selection example of surge absorbers to be used (Note 7, 8)		For the suppressed voltage 125V	TND20V-680KB			
		For the suppressed voltage 350V	TND10V-221KB			

Note 1. There is no manual release mechanism. Use a 24VDC power supply to release the brake electrically.

2. The value for initial ON gap at 20°C (68°F).

3. Brake gap increases as the brake lining wears, but the gap is not adjustable. Therefore, the brake life is indicated as the number of braking cycles available before the gap adjustment is required.

4. Always prepare the power supply exclusively used for the electromagnetic brake.

5. The above values are typical initial values and not guaranteed values.

6. These values are measured values and not guaranteed values.

7. Select the electromagnetic brake control relay properly, considering the characteristics of the electromagnetic brake and surge absorber.

8. Manufactured by Nippon Chemi-Con Corporation.

12. SERVO MOTOR

12.6.4 Servo motor with a reduction gear



CAUTION

- The servo motor with a reduction gear must be installed in the specified direction. Otherwise, it can leak oil, leading to a fire or fault.
- Install the servo motor with a reduction gear in the specified direction. Improper installation causes oil leakage, leading to a fire and malfunction.

Servo motors are available with a reduction gear designed for general industrial machines compliant and precision applications compliant.

Servo motors with an electromagnetic brake are also available.

(1) For general industrial machines compliant (G1)

(a) Manufacturing range

The following table indicates the reduction ratios and actual reduction ratios of the servo motors with a reduction gear for general industrial machines compliant. The servo motors with a reduction gear of the following reduction ratios are available.

Servo motor	Nominal reduction ratio	Actual reduction ratio
HF-KP053G1	1/5	9/44
	1/12	49/576
	1/20	25/484
HF-KP13G1	1/5	9/44
	1/12	49/576
	1/20	25/484
HF-KP23G1	1/5	19/96
	1/12	25/288
	1/20	253/5000
HF-KP43G1	1/5	19/96
	1/12	25/288
	1/20	253/5000

12. SERVO MOTOR

(b) Specifications

Item	Description			
Servo motor	HF-KP □ G1			
Mounting method	Flange mounting			
Mounting direction	In any directions			
Lubrication method	Packed with	Grease lubrication (Already packed) (Note 1)		
		50 ▪ 100W	200W ▪ 400W 1/12 ▪ 1/20	200W ▪ 400W 1/5
		Mobilplex 46 Exxon Mobil Corporation	Molynoc AP2 Nippon Oil Corporation	Mobil Grease SP Exxon Mobil Corporation
Output shaft rotating direction	Same as the servo motor output shaft direction.			
With an electromagnetic brake	Available			
Backlash	60 minutes or less at reduction gear output shaft			
Permissible load to motor inertia moment ratio (converting into the servo motor shaft) (Note 2)	For 50W, 100W: 5 times or less For 200W, 400W: 7 times or less			
Permissible speed (servo motor shaft)	4500 r/min			
IP rating (reduction gear area)	IP44 equivalent			
Reduction gear efficiency (Note 3)	45 to 75%			

Note 1. Already packed with the grease.

2. If the above indicated value is exceeded, please contact your local sales office.

3. The reduction gear efficiency differs depending on the reduction ratio. Also, it varies depending on the use conditions such as the output torque, speed, temperature, etc. The numerical value in the table is a typical value in the rated torque, rated speed and typical temperature, and not a guaranteed value.

12. SERVO MOTOR

(c) Permissible loads of servo motor shaft

The permissible radial load in the table is the value measured at the center of the reduction gear output shaft.

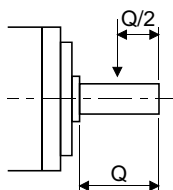

Q: Length of axis
(Refer to section 6.8.3, 6.8.4 in the Servo Motor
INSTRUCTION MANUAL (Vol.2).)

Servo motor	Reduction ratio	Permissible load (Note)			
		Permissible radial load		Permissible thrust load	
		[N]	[lb]	[N]	[lb]
HF-KP053G1	1/5	150	33.7	200	45.0
	1/12	240	54.0	320	71.9
	1/20	370	83.2	450	101
HF-KP13G1	1/5	150	33.7	200	45.0
	1/12	240	54.0	320	71.9
	1/20	370	83.2	450	101
HF-KP23G1	1/5	330	74.2	350	78.7
	1/12	710	160	720	162
	1/20	780	175	780	175
HF-KP43G1	1/5	330	74.2	350	78.7
	1/12	710	160	720	162
	1/20	760	171	760	171

Note. Do not subject the shaft to load greater than this value.

The values in the table are applicable when the loads are applied independently.

12. SERVO MOTOR

(2) For precision applications compliant (G5, G7)

(a) Manufacturing range

The symbols (14A, 20A, 32A) in the following table indicate the model numbers of the reduction gears assembled to the servo motors. Servo motors with a reduction gear having the indicated reduction gear model numbers are available. The reduction gear model number indicates □□□ of the reduction number model name HPG- □□□ -05...

Servo motor	Reduction ratio				
	1/5	1/11	1/21	1/33	1/45
HF-KP053G5, HF-KP053G7					
HF-KP13G5, HF-KP13G7		14A			
HF-KP23G5, HF-KP23G7			20A		
HF-KP43G5, HF-KP43G7				32A	

(b) Specifications

Item	Description
Servo motor	HF-KP □ G5, HF-KP □ G7
Mounting method	Flange mounting
Mounting direction	In any directions
Lubrication method	Grease lubrication (Already packed) (Note 1)
Packed with	Harmonic grease SK-2 (Harmonic Drive Systems)
Output shaft rotating direction	Same as the servo motor output shaft direction.
With an electromagnetic brake	Available
Backlash	3 minutes or less at reduction gear output shaft
Permissible load to motor inertia moment ratio (converting into the servo motor shaft) (Note 2)	For 50W, 100W: 10 times or less For 200W, 400W: 14 times or less
Permissible speed (servo motor shaft)	4500 r/min (Note 5)
IP rating (reduction gear area)	IP44 (Note 6)
Reduction gear efficiency (Note 3)	58 to 87 % (Note 4)

Note 1. Already packed with the grease.

2. If the above indicated value is exceeded, please contact your local sales office.
3. The reduction gear efficiency differs depending on the reduction ratio. Also, it varies depending on the use conditions such as the output torque, speed, temperature, etc. The numerical value in the table is a typical value in the rated torque, rated speed and typical temperature, and not a guaranteed value.
4. The reduction gear efficiency of the HF-KP053 is 22 to 41%.
5. When combining with the MR-JN series servo amplifier.
6. Except for the shaft-through portion.

12. SERVO MOTOR

(c) Permissible loads to servo motor shaft

The radial load point of a precision reduction gear is as shown below.

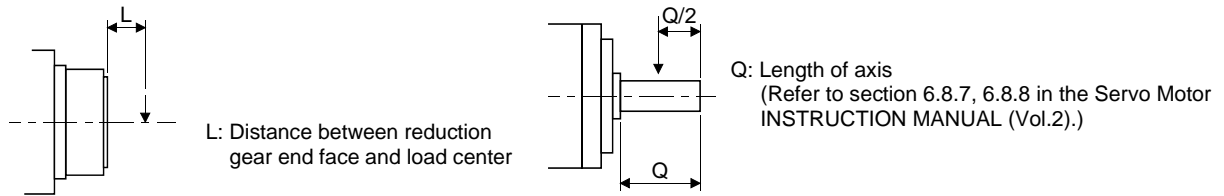

Flange-mounting flange output type for precision application compliant (G5)

Flange-mounting shaft output type for precision application compliant (G7)

Servo motor	Reduction ratio	Radial load point L [mm]	Permissible load (Note)			
			Permissible radial load		Permissible thrust load	
			[N]	[lb]	[N]	[lb]
HF-KP053G5, HF-KP053G7	1/5	23	177	39.8	706	159
	1/11	23	224	50.4	895	201
	1/21	23	272	61.1	1087	224
	1/33	23	311	69.9	1244	280
	1/45	23	342	76.9	1366	307
HF-KP13G5, HF-KP13G7	1/5	23	177	39.8	706	159
	1/11	23	224	50.4	895	201
	1/21	23	272	61.1	1087	224
	1/33	32	733	165	2581	570
	1/45	32	804	181	2833	637
HF-KP23G5, HF-KP23G7	1/5	23	177	39.8	706	159
	1/11	23	224	50.4	895	201
	1/21	32	640	144	2254	507
	1/33	32	733	165	2581	570
	1/45	32	804	181	2833	637
HF-KP43G5, HF-KP43G7	1/5	23	177	39.8	706	159
	1/11	32	527	118	1856	4170
	1/21	32	640	309	2254	1230
	1/33	57	1252	281	4992	1120
	1/45	57	1374	309	5478	1230

Note. Do not subject the shaft to load greater than this value.

The values in the table assume that the loads are applied independently.

12. SERVO MOTOR

(d) Special shaft servo motors

Servo motors with a special shaft having keyway (with single pointed keys) are available for the flange mounting shaft output type for precision applications compliant (G7).

[Unit: mm]

Servo motor	Reduction gear model number	Q	ϕS	W	T	QK	U	Y
HF-KP □ G7K	14A	28	16h7	5	5	25	3	M4 Depth 8
	20A	42	25h7	8	7	36	4	M6 Depth 12
	32A	82	40h7	12	8	70	5	M10 Depth 20

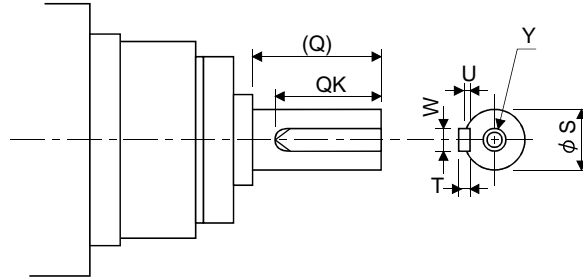

12.6.5 Connector installation

If the connector is not fixed securely, it may come off or may not produce a splash-proof effect during operation. To achieve the IP rating of IP65, pay attention to the following points and install the connectors.

(1) When screwing the connector, hold the connector still and gradually tighten the screws in a crisscross pattern.

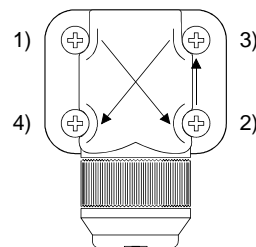

Tightening sequence
1) → 2) → 3) → 4)

For power supply and encoder connectors

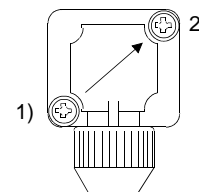

Tightening sequence
1) → 2)

For brake connector

12. SERVO MOTOR

(2) Tighten the screws evenly. Tightening torques are as indicated below.

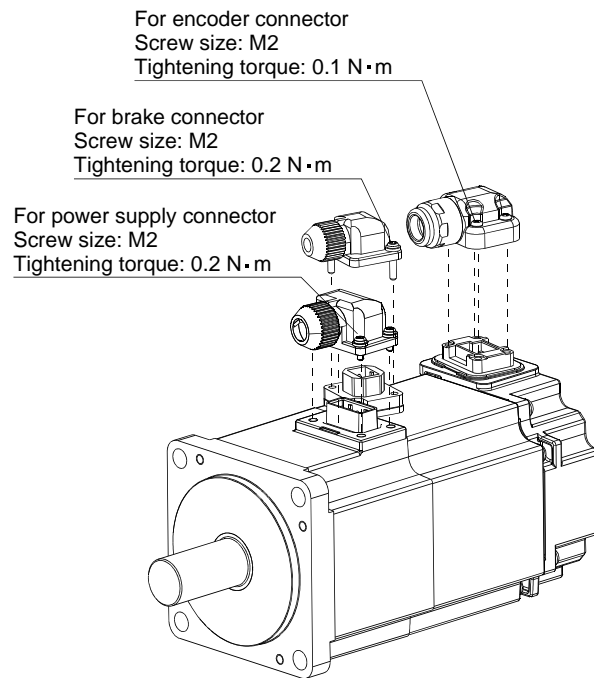

(3) The servo motor fitting part of each connector is provided with a splash-proof seal (O ring). When installing the connector, take care to prevent the seal (O ring) from dropping and being pinched. If the seal (O ring) has dropped or is pinched, a splash-proof effect is not produced.

13. POSITIONING MODE

13. POSITIONING MODE

13.1 Selection method of each operation mode

This section provides the selection method of each operation mode.

(1) Point table method

Selection item of operation mode		Parameter No. PA01 setting	Input device setting (Note)		Refer to	
			MD0	DI0 to DI2		
Automatic operation mode for point table method	One-time positioning operation	□□□6	ON	Option	Section 13.3.2 (1)	
	Automatic continuous operation				Varied speed operation	Section 13.3.2 (2) (b)
					Automatic continuous positioning operation	Section 13.3.2 (2) (c)
Manual operation mode	JOG operation		OFF	/	Section 13.5.1	
	Manual pulse generator operation				Section 13.5.2	
Home position return mode	Dog type		ON	All OFF	Section 13.6.3	
	Count type				Section 13.6.4	
	Data set type				Section 13.6.5	
	Stopper type				Section 13.6.6	
	Home position ignorance (Servo-on position as home position)				Section 13.6.7	
	Dog type rear end reference	Section 13.6.8				
	Count type front end reference	Section 13.6.9				
Dog cradle type	Section 13.6.10					

Note. MD0: Automatic/manual selection

DI0 to DI2: Point table No./Program No. selection 1 to 3

(2) Program method

Selection item of operation mode		Parameter No. PA01 setting	Input device setting (Note 1)		Refer to
			MD0	DI0 to DI2	
Automatic operation mode for program method		□□□7	ON	Option	Section 13.4
Manual operation mode	JOG operation		OFF	/	Section 13.5.1
	Manual pulse generator operation				Section 13.5.2
Home position return mode	Dog type		ON	(Note 2) Option	Section 13.6.3
	Count type				Section 13.6.4
	Data set type				Section 13.6.5
	Stopper type				Section 13.6.6
	Home position ignorance (Servo-on position as home position)				Section 13.6.7
	Dog type rear end reference				Section 13.6.8
	Count type front end reference				Section 13.6.9
Dog cradle type	Section 13.6.10				

Note 1. MD0: Automatic/manual selection

DI0 to DI2: Point table No./Program No. selection 1 to 3

2. Select a program that has the home position return "ZRT" command.

13. POSITIONING MODE

13.2 Signals

13.2.1 I/O signal connection example

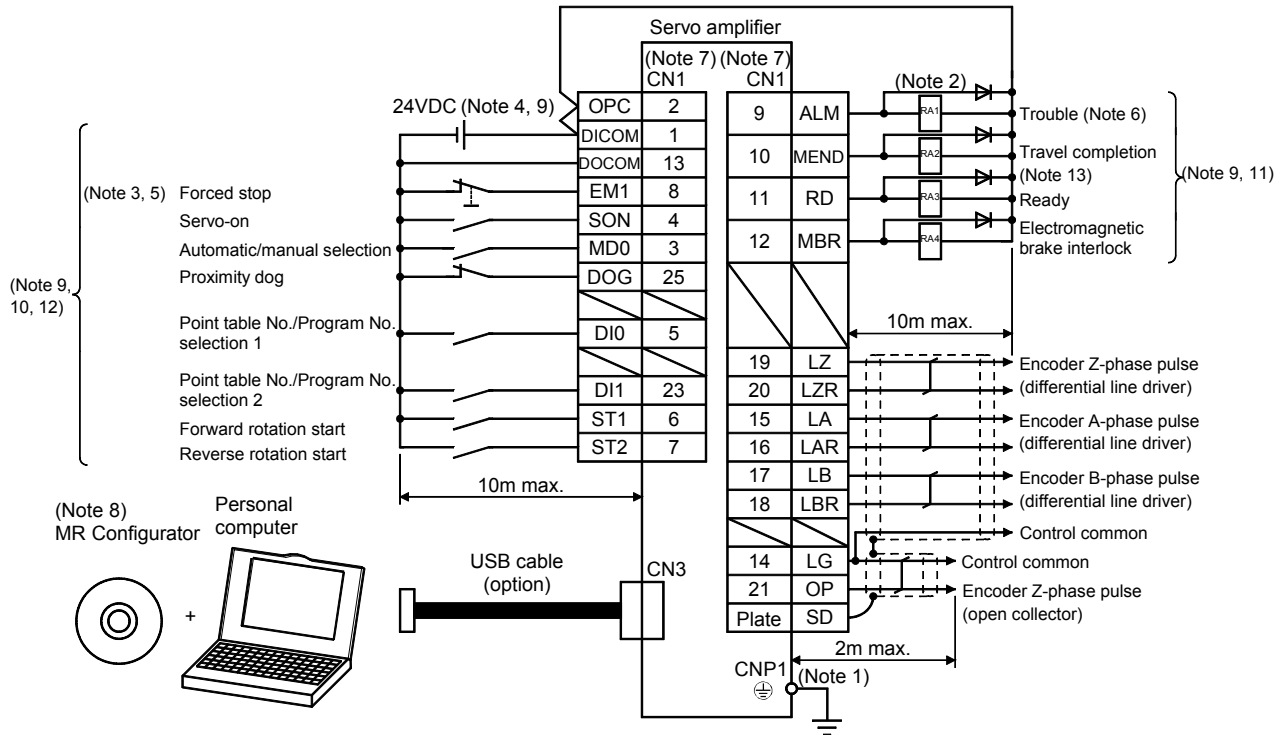

- Note 1. To prevent an electric shock, always connect the protective earth (PE) terminal of the (terminal marked \oplus) servo amplifier to the protective earth (PE) of the control box.
2. Connect the diode in the correct direction. If it is connected reversely, the servo amplifier will be faulty and will not output signals, disabling the emergency stop and other protective circuits.
 3. The forced stop switch (normally closed contact) must be installed.
 4. Supply 24VDC \pm 10% 200mA current for interfaces from the outside. 200mA is the value applicable when all I/O signals are used. The current capacity can be decreased by reducing the number of I/O points. Refer to section 3.8.2 (1) that gives the current value necessary for the interface.
 5. When starting operation, always turn on the forced stop (EM1). (Normally closed contacts)
 6. Trouble (ALM) turns on in normal alarm-free condition.
 7. The pins with the same signal name are connected in the servo amplifier.
 8. Use MRZJW3-SETUP221E (version C4 or later).
 9. For the sink I/O interface. For the source I/O interface, refer to section 3.8.3. However, pin 23 and pin 25 cannot be used at the source interface.
 10. The assigned signals can be changed using parameter No. PD02, PD04, PD06, PD08, PD10, PD12, or PD14.
 11. The assigned signals can be changed using parameter No. PD15 to PD18.
 12. The forward rotation stroke end (LSP) and the reverse rotation stroke end (LSN) automatically switch ON if not assigned to the external input signals.
 13. Set "□□24" in parameter No. PD16 to assign travel completion (MEND).

13. POSITIONING MODE

13.2.2 Connectors and signal arrangements

POINT	<ul style="list-style-type: none"> The pin configurations of the connectors are as viewed from the cable connector wiring section.
-------	---

The front view shown below is that of MR-JN-20A(1) or smaller. Refer to chapter 9 OUTLINE DRAWINGS for the appearances and connector layouts of the other servo amplifiers.

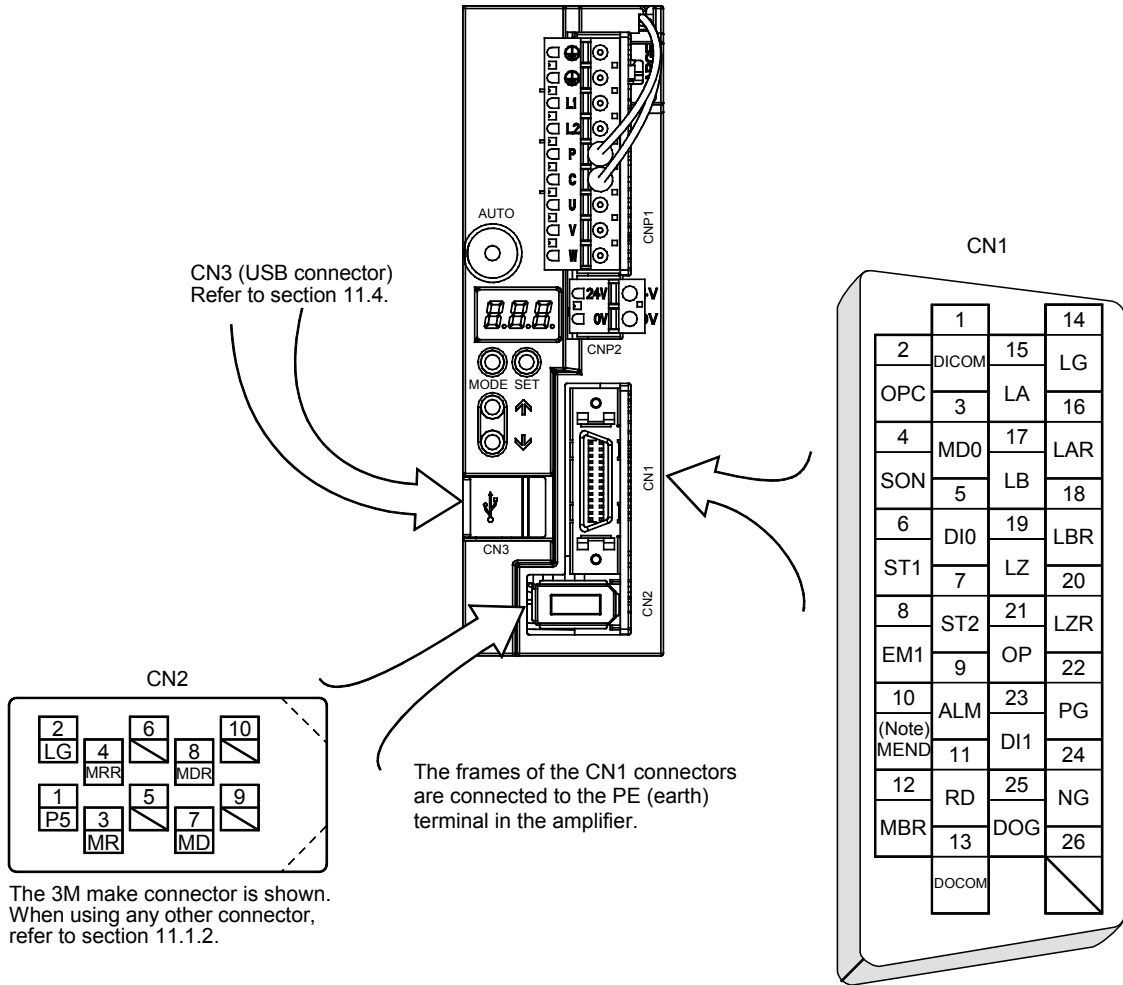

Note. Set "□□24" in parameter No. PD16 to assign travel completion (MEND).

13. POSITIONING MODE

13.2.3 Signal explanations

For the I/O interfaces (symbols in I/O division column in the table), refer to section 3.8.2. In the positioning mode field of the table

CP: Point table method CL: Program method

○ : Denotes that the signal may be used in the initial setting status.

△ : Denotes that the signal may be used by setting parameter No. PD02, PD04, PD06, PD08, PD10, PD12, and PD14 to PD18.

The pin No.s in the connector pin No. column are those in the initial status.

(1) I/O devices

(a) Input devices

Device	Symbol	Connector pin No.	Functions/Applications	I/O division	Positioning mode																									
					CP	CL																								
Forced stop	EM1	CN1-8	When EMG is turned off (contact between commons is opened), the servo amplifier falls in a forced stop state in which the base circuit is shut off, and the dynamic brake activates. When EM1 is turned on (contact between commons is shorted) in the forced stop state, the state can be reset.	DI-1	○	○																								
Proximity dog	DOG	CN1-25	When DOG is turned OFF, the proximity dog is detected. The polarity of dog detection can be changed using parameter No. PE03. <table border="1" style="margin-left: auto; margin-right: auto;"> <thead> <tr> <th>Parameter No. PE03</th> <th>Proximity dog (DOG) detection polarity</th> </tr> </thead> <tbody> <tr> <td><input type="checkbox"/> 0 <input type="checkbox"/> <input type="checkbox"/> (initial value)</td> <td>OFF</td> </tr> <tr> <td><input type="checkbox"/> 1 <input type="checkbox"/> <input type="checkbox"/></td> <td>ON</td> </tr> </tbody> </table>	Parameter No. PE03	Proximity dog (DOG) detection polarity	<input type="checkbox"/> 0 <input type="checkbox"/> <input type="checkbox"/> (initial value)	OFF	<input type="checkbox"/> 1 <input type="checkbox"/> <input type="checkbox"/>	ON	DI-1	○	○																		
Parameter No. PE03	Proximity dog (DOG) detection polarity																													
<input type="checkbox"/> 0 <input type="checkbox"/> <input type="checkbox"/> (initial value)	OFF																													
<input type="checkbox"/> 1 <input type="checkbox"/> <input type="checkbox"/>	ON																													
Forward rotation stroke end	LSP		To start operation, turn LSP/LSN on. Turn it off to bring the motor to a sudden stop and make it servo-locked. <table border="1" style="margin-left: auto; margin-right: auto;"> <thead> <tr> <th colspan="2">(Note) Device</th> <th colspan="2">Operation</th> </tr> <tr> <th>LSP</th> <th>LSN</th> <th>CCW direction</th> <th>CW direction</th> </tr> </thead> <tbody> <tr> <td>1</td> <td>1</td> <td>○</td> <td>○</td> </tr> <tr> <td>0</td> <td>1</td> <td></td> <td>○</td> </tr> <tr> <td>1</td> <td>0</td> <td>○</td> <td></td> </tr> <tr> <td>0</td> <td>0</td> <td></td> <td></td> </tr> </tbody> </table> <p>Note. 0: off 1: on</p>	(Note) Device		Operation		LSP	LSN	CCW direction	CW direction	1	1	○	○	0	1		○	1	0	○		0	0			DI-1	△	△
(Note) Device		Operation																												
LSP	LSN	CCW direction	CW direction																											
1	1	○	○																											
0	1		○																											
1	0	○																												
0	0																													
Reverse rotation stroke end	LSN		A stopping method can be changed by parameter No. PD20. Set parameter No. PD01 as indicated below to switch on the signals (keep terminals shorted) automatically in the servo amplifier. <table border="1" style="margin-left: auto; margin-right: auto;"> <thead> <tr> <th rowspan="2">Parameter No. PD01</th> <th colspan="2">Status</th> </tr> <tr> <th>LSP</th> <th>LSN</th> </tr> </thead> <tbody> <tr> <td><input type="checkbox"/> 4 <input type="checkbox"/> <input type="checkbox"/></td> <td>Automatic ON</td> <td></td> </tr> <tr> <td><input type="checkbox"/> 8 <input type="checkbox"/> <input type="checkbox"/></td> <td></td> <td>Automatic ON</td> </tr> <tr> <td><input type="checkbox"/> C <input type="checkbox"/> <input type="checkbox"/></td> <td>Automatic ON</td> <td>Automatic ON</td> </tr> </tbody> </table> <p>If LSP and LSN are not assigned to the external input signals, they turn ON automatically regardless of the value set in parameter No. PD01. When LSP or LSN turns OFF, an external stroke limit warning (99. <input type="checkbox"/>) occurs, and warning (WNG) turns OFF. However, when using WNG, set parameter No. PD15 to PD18 to make it usable.</p>	Parameter No. PD01	Status		LSP	LSN	<input type="checkbox"/> 4 <input type="checkbox"/> <input type="checkbox"/>	Automatic ON		<input type="checkbox"/> 8 <input type="checkbox"/> <input type="checkbox"/>		Automatic ON	<input type="checkbox"/> C <input type="checkbox"/> <input type="checkbox"/>	Automatic ON	Automatic ON	DI-1	△	△										
Parameter No. PD01	Status																													
	LSP	LSN																												
<input type="checkbox"/> 4 <input type="checkbox"/> <input type="checkbox"/>	Automatic ON																													
<input type="checkbox"/> 8 <input type="checkbox"/> <input type="checkbox"/>		Automatic ON																												
<input type="checkbox"/> C <input type="checkbox"/> <input type="checkbox"/>	Automatic ON	Automatic ON																												

13. POSITIONING MODE

Device	Symbol	Connector pin No.	Functions/Applications	I/O division	Positioning mode																											
					CP	CL																										
Servo-on	SON	CN1-4	<p>When SON is turned on, the power is supplied to the base circuit and the servo amplifier is ready to operate (servo-on).</p> <p>When SON is turned off, the power to the base circuit is shut off and the servo motor coasts.</p> <p>Set parameter No. PD01 to "□□□4" to switch this signal on (keep terminals connected) automatically in the servo amplifier.</p>	DI-1	○	○																										
Reset	RES		<p>When RES is turned on for 50ms or longer, an alarm can be deactivated.</p> <p>Some alarms cannot be deactivated by the reset (RES). Refer to section 8.1.</p> <p>Turning RES on in an alarm-free status shuts off the base circuit. The base circuit is not shut off when "□□1□" is set in parameter No. PD20.</p> <p>This device is not designed to make a stop. Do not turn it ON during operation.</p>	DI-1	△	△																										
Automatic /manual selection	MD0		CN1-3	Turning MD0 ON selects the automatic operation mode, and turning it OFF selects the manual operation mode.	DI-1	○	○																									
Internal torque limit selection	TL1		<p>The internal torque limit 2 (parameter No. PC14) becomes valid by turning TL1 on.</p> <p>The forward torque limit (parameter No. PA11) and the reverse torque limit (parameter No. PA12) are always valid.</p> <p>The smallest torque limit among the valid forward and reverse torque limits is the actual torque limit value.</p> <table border="1" data-bbox="531 1137 1190 1632"> <thead> <tr> <th rowspan="2">(Note) Input device</th> <th colspan="2" rowspan="2">Comparison between limit values</th> <th colspan="2">Valid torque limit value</th> </tr> <tr> <th>Forward rotation</th> <th>Reverse rotation</th> </tr> </thead> <tbody> <tr> <td>TL1</td> <td></td> <td></td> <td>Parameter No. PA11</td> <td>Parameter No. PA12</td> </tr> <tr> <td>0</td> <td></td> <td></td> <td>Parameter No. PA11</td> <td>Parameter No. PA12</td> </tr> <tr> <td rowspan="2">1</td> <td>Parameter No. PC14 ></td> <td>Parameter No. PA11 Parameter No. PA12</td> <td>Parameter No. PA11</td> <td>Parameter No. PA12</td> </tr> <tr> <td>Parameter No. PC14 <</td> <td>Parameter No. PA11 Parameter No. PA12</td> <td>Parameter No. PC14</td> <td>Parameter No. PC14</td> </tr> </tbody> </table> <p>Note. 0: off 1: on</p> <p>Refer to section 3.6.1(4).</p>	(Note) Input device	Comparison between limit values		Valid torque limit value		Forward rotation	Reverse rotation	TL1			Parameter No. PA11	Parameter No. PA12	0			Parameter No. PA11	Parameter No. PA12	1	Parameter No. PC14 >	Parameter No. PA11 Parameter No. PA12	Parameter No. PA11	Parameter No. PA12	Parameter No. PC14 <	Parameter No. PA11 Parameter No. PA12	Parameter No. PC14	Parameter No. PC14	DI-1	△	△
(Note) Input device	Comparison between limit values		Valid torque limit value																													
			Forward rotation	Reverse rotation																												
TL1			Parameter No. PA11	Parameter No. PA12																												
0			Parameter No. PA11	Parameter No. PA12																												
1	Parameter No. PC14 >	Parameter No. PA11 Parameter No. PA12	Parameter No. PA11	Parameter No. PA12																												
	Parameter No. PC14 <	Parameter No. PA11 Parameter No. PA12	Parameter No. PC14	Parameter No. PC14																												
Temporary stop/Restart	TSTP	<p>Turning TSTP ON during automatic operation makes a temporary stop.</p> <p>Turning TSTP ON again makes a restart.</p> <p>Forward rotation start (ST1) or Reverse rotation start (ST2) is ignored if it is turned ON during a temporary stop.</p> <p>When the automatic operation mode is changed to the manual operation mode during a temporary stop, the movement remaining distance is erased.</p> <p>During a home position return or during JOG operation, Temporary stop/ Restart input is ignored.</p>	DI-1	△	△																											

13. POSITIONING MODE

Device	Symbol	Connector pin No.	Functions/Applications	I/O division	Positioning mode	
					CP	CL
Proportion control	PC		<p>When PC is turned on, the type of the speed loop switches from the proportional integral type to the proportional type.</p> <p>If the servo motor at a stop is rotated even one pulse due to any external factor, it generates torque to compensate for a position shift. When the servo motor shaft is to be locked mechanically after travel completion (MEND), switching on the proportion control (PC) upon travel completion (MEND) will suppress the unnecessary torque generated to compensate for a position shift.</p> <p>In case of locking the servo motor shaft for a long time, turn on the internal torque limit selection (TL1) simultaneously with the proportion control (PC). Then, set the internal torque limit 2 (parameter No. PC14) in order to make the torque lower than the rating.</p>	DI-1	△	△
Forward rotation start	ST1	CN1-6	<p>1. In absolute value command system</p> <p>Turning ST1 ON for automatic operation executes positioning once on the basis of the position data set to the point table.</p> <p>Turning ST1 ON for a home position return immediately starts a home position return.</p> <p>Keeping ST1 ON for JOG operation performs rotation in the forward rotation direction.</p> <p>Forward rotation indicates the address increasing direction.</p> <p>2. In incremental value command system</p> <p>Turning ST1 ON for automatic operation executes positioning once in the forward rotation direction on the basis of the position data set to the point table.</p> <p>Turning ST1 ON for a home position return immediately starts a home position return.</p> <p>Keeping ST1 ON for JOG operation performs rotation in the forward rotation direction.</p> <p>Forward rotation indicates the address increasing direction.</p>	DI-1	○	
Reverse rotation start	ST2	CN1-7	<p>Use this device in the incremental value command system.</p> <p>Turning ST2 ON for automatic operation executes positioning once in the reverse rotation direction on the basis of the position data set to the point table.</p> <p>Keeping ST2 ON for JOG operation performs rotation in the reverse rotation direction.</p> <p>Reverse rotation indicates the address decreasing direction.</p>	DI-1	○	
Forward rotation start	ST1	CN1-6	<p>1. For automatic operation mode</p> <p>Turning ST1 ON executes the program operation selected in DI0 to DI2.</p> <p>2. For JOG operation in manual operation mode</p> <p>Keeping ST1 ON performs rotation in the forward rotation direction. Forward rotation indicates the address increasing direction.</p>	DI-1		○
Reverse rotation start	ST2	CN1-7	<p>Keeping ST2 ON in JOG operation in manual operation mode performs rotation in the reverse rotation direction. Reverse rotation indicates the address decreasing direction.</p> <p>ST2 is invalid in other operation modes.</p>	DI-1		○
Gain changing	CDP		<p>The values of the load to motor inertia moment ratio and the gains are changed to the value set in parameter No. PB29 to PB34 by turning CDP on.</p>	DI-1	△	△

13. POSITIONING MODE

Device	Symbol	Connector pin No.	Functions/Applications	I/O division	Positioning mode																																																			
					CP	CL																																																		
Point table No. /Program No. selection 1	DI0	CN1-5	<p><In point table method> The point table No. and the home position return mode are selected by DI0 to DI2.</p> <p><In program method> The program No. is selected by DI0 to DI2.</p>	DI-1	○	○																																																		
Point table No. /Program No. selection 2	DI1	CN1-23	<table border="1"> <thead> <tr> <th colspan="3">(Note) Device</th> <th colspan="2">Selection description</th> </tr> <tr> <th>DI2</th> <th>DI1</th> <th>DI0</th> <th>Point table method</th> <th>Program method</th> </tr> </thead> <tbody> <tr> <td>0</td> <td>0</td> <td>0</td> <td>Home position return mode</td> <td>Program No. 1</td> </tr> <tr> <td>0</td> <td>0</td> <td>1</td> <td>Point table No. 1</td> <td>Program No. 2</td> </tr> <tr> <td>0</td> <td>1</td> <td>0</td> <td>Point table No. 2</td> <td>Program No. 3</td> </tr> <tr> <td>0</td> <td>1</td> <td>1</td> <td>Point table No. 3</td> <td>Program No. 4</td> </tr> <tr> <td>1</td> <td>0</td> <td>0</td> <td>Point table No. 4</td> <td>Program No. 5</td> </tr> <tr> <td>1</td> <td>0</td> <td>1</td> <td>Point table No. 5</td> <td>Program No. 6</td> </tr> <tr> <td>1</td> <td>1</td> <td>0</td> <td>Point table No. 6</td> <td>Program No. 7</td> </tr> <tr> <td>1</td> <td>1</td> <td>1</td> <td>Point table No. 7</td> <td>Program No. 8</td> </tr> </tbody> </table> <p>Note. 0: off 1: on</p>	(Note) Device			Selection description		DI2	DI1	DI0	Point table method	Program method	0	0	0	Home position return mode	Program No. 1	0	0	1	Point table No. 1	Program No. 2	0	1	0	Point table No. 2	Program No. 3	0	1	1	Point table No. 3	Program No. 4	1	0	0	Point table No. 4	Program No. 5	1	0	1	Point table No. 5	Program No. 6	1	1	0	Point table No. 6	Program No. 7	1	1	1	Point table No. 7	Program No. 8	DI-1	○	○
(Note) Device				Selection description																																																				
DI2	DI1	DI0		Point table method	Program method																																																			
0	0	0		Home position return mode	Program No. 1																																																			
0	0	1		Point table No. 1	Program No. 2																																																			
0	1	0		Point table No. 2	Program No. 3																																																			
0	1	1		Point table No. 3	Program No. 4																																																			
1	0	0		Point table No. 4	Program No. 5																																																			
1	0	1	Point table No. 5	Program No. 6																																																				
1	1	0	Point table No. 6	Program No. 7																																																				
1	1	1	Point table No. 7	Program No. 8																																																				
Point table No. /Program No. selection 3	DI2			DI-1	△	△																																																		
Program input 1	PI1		Turn PI1 on to resume the step stopped by the SYNC (1) command in the program.	DI-1		△																																																		

(b) Output devices

Device	Symbol	Connector pin No.	Functions/Applications	I/O division	Positioning mode	
					CP	CL
Trouble	ALM	CN1-9	<p>ALM turns off when power is switched off or the protective circuit is activated to shut off the base circuit.</p> <p>When there is no alarm, ALM turns on approximately 1s after power-on.</p>	DO-1	○	○
Ready	RD	CN1-11	RD turns on when the servo motor is ready for the operation after turning on the servo-on (SON).	DO-1	○	○
In-position	INP	CN1-10	<p>INP turns on when the number of droop pulses is in the preset in-position range. The in-position range can be changed using parameter No. PA10.</p> <p>When the in-position range is increased, may be kept connected during low-speed rotation.</p> <p>INP turns on when servo-on turns on.</p> <p>If parameter No. PA04 is set to "□□1" and the overload tough drive function is enabled, the INP ON time during the overload tough drive is delayed. The delay time can be limited by parameter No. PC26.</p>	DO-1	○	○
Electromagnetic brake interlock	MBR	CN1-12	<p>MBR turns off when the servo is switched off or an alarm occurs.</p> <p>At an alarm occurrence, MBR turns off regardless of the base circuit status.</p>	DO-1	○	○
Home position return completion	ZP		<p>ZP turns ON when operation is ready to start, but turns OFF in any of the following cases.</p> <p>1) Home position return has not been made. 2) While a home position return is being made.</p> <p>When any of 1) or 2) has not occurred and a home position return is already completed at least once, Home position return completion (ZP) turns to the same output status as Ready (RD).</p>	DO-1	△	△

13. POSITIONING MODE

Device	Symbol	Connector pin No.	Functions/Applications	I/O division	Positioning mode	
					CP	CL
Temporary stop	PUS		PUS turns ON when deceleration is started to make a stop by Temporary stop/Restart (TSTP). When Temporary stop/Restart (TSTP) is made valid again to resume operation, PUS turns OFF.	DO-1	△	△
Travel completion	MEND		MEND turns ON when In-position (INP) turns ON and the command remaining distance is "0". MEND turns ON when servo-on turns ON. If parameter No. PA04 is set to "□□ 1" and the overload tough drive function is enabled, the INP ON time during the overload tough drive is delayed. ON time of MEND is also delayed interlocked with this.	DO-1	△	△
Rough match	CPO		CPO turns ON when the command remaining distance becomes less than the rough match output range set in the parameter. CPO is not output while the base circuit is off. CPO turns ON at servo-on.	DO-1	△	
Zero speed	ZSP		<p>ZSP turns on when the servo motor speed is zero speed (50r/min) or less. Zero speed can be changed using parameter No. PC10. Example Zero speed is 50r/min</p> <p>ZSP turns on 1) when the servo motor is decelerated to 50r/min, and ZSP turns off 2) when the servo motor is accelerated to 70r/min again. ZSP turns on 3) when the servo motor is decelerated again to 50r/min, and turns off 4) when the servo motor speed has reached -70r/min. The range from the point when the servo motor speed has reached ON level, and ZSP turns on, to the point when it is accelerated again and has reached OFF level is called hysteresis width. Hysteresis width is 20r/min for MR-JN-A servo amplifier. If parameter No. PA04 is set to "□□ 1" and the overload tough drive function is enabled, the ZSP ON time during the overload tough drive is delayed. The delay time can be limited by parameter No. PC26.</p>	DO-1	△	△
Limiting torque	TLC		TLC turns ON when the generated torque reaches the value set to the forward torque limit (parameter No. PA11), the reverse torque limit (parameter No. PA12) or the internal torque limit 2 (parameter No. PC14). (Refer to section 3.6.1(4).)	DO-1	△	△
Warning	WNG		When a warning occurs, WNG turns on. When there is no warning, WNG turns off approximately 1s after power-on.	DO-1	△	△
During variable gain selection	CDPS		CDPS is on during gain changing.	DO-1	△	△

13. POSITIONING MODE

Device	Symbol	Connector pin No.	Functions/Applications	I/O division	Positioning mode																																				
					CP	CL																																			
During tough drive	MTTR		If the instantaneous power failure tough drive function selection is enabled, MTTR turns on when the instantaneous tough drive activates. If parameter No. PD20 is set to "□ 1 □ □", MTTR also turns on when the overload tough drive activates.	DO-1	△	△																																			
Position range	POT		POT turns ON when the actual current position falls within the range set in the parameter. It is OFF when a home position return is not yet completed or while the base circuit is shut off.	DO-1	△	△																																			
Point table No. output 1	PT0		<table border="1"> <thead> <tr> <th colspan="3">(Note) Device</th> <th rowspan="2">Description</th> </tr> <tr> <th>PT2</th> <th>PT1</th> <th>PT0</th> </tr> </thead> <tbody> <tr> <td>0</td> <td>0</td> <td>1</td> <td>Point table No. 1</td> </tr> <tr> <td>0</td> <td>1</td> <td>0</td> <td>Point table No. 2</td> </tr> <tr> <td>0</td> <td>1</td> <td>1</td> <td>Point table No. 3</td> </tr> <tr> <td>1</td> <td>0</td> <td>0</td> <td>Point table No. 4</td> </tr> <tr> <td>1</td> <td>0</td> <td>1</td> <td>Point table No. 5</td> </tr> <tr> <td>1</td> <td>1</td> <td>0</td> <td>Point table No. 6</td> </tr> <tr> <td>1</td> <td>1</td> <td>1</td> <td>Point table No. 7</td> </tr> </tbody> </table>	(Note) Device			Description	PT2	PT1	PT0	0	0	1	Point table No. 1	0	1	0	Point table No. 2	0	1	1	Point table No. 3	1	0	0	Point table No. 4	1	0	1	Point table No. 5	1	1	0	Point table No. 6	1	1	1	Point table No. 7	DO-1	△	
(Note) Device				Description																																					
PT2	PT1	PT0																																							
0	0	1		Point table No. 1																																					
0	1	0		Point table No. 2																																					
0	1	1		Point table No. 3																																					
1	0	0		Point table No. 4																																					
1	0	1	Point table No. 5																																						
1	1	0	Point table No. 6																																						
1	1	1	Point table No. 7																																						
Point table No. output 2	PT1		DO-1	△																																					
Point table No. output 3	PT2		DO-1	△																																					
Program output 1	OUT1		OUT1 turns on when the OUTON (1) command in the program is given. OUT1 turns off when the OUTOF command is given. By setting parameter No. PE14, the time to turn it off can be set.	DO-1		△																																			
SYNC synchronous output	SOUT		Waiting for input of program SYNC (1).	DO-1		△																																			

(c) Input signals

Signal	Symbol	Connector pin No.	Functions/Applications	I/O division	Positioning mode	
					CP	CL
Forward rotation pulse train Reverse rotation pulse train	PP		Used to connect the manual pulse generator (MR-HDP01). (Refer to sections 11.14 and 13.5.2.) When using PP or NP, set parameter No. PD02 to make it usable. This function is not enabled only with the input of PG or NG.	DI-2	△	△
	NP				△	△
	PG	CN1-22			○	○
	NG	CN1-24			○	○

13. POSITIONING MODE

(3) Output signals

Signal	Symbol	Connector pin No.	Functions/Applications	I/O division	Positioning mode	
					CP	CL
Encoder Z-phase pulse (Open collector)	OP	CN1-21	Outputs the zero-point signal of the encoder. One pulse is output per servo motor revolution. OP turns on when the zero-point position is reached. (Negative logic) The minimum pulse width is about 400 μ s. For home position return using this pulse, set the creep speed to 100r/min. or less.	DO-2	<input type="radio"/>	<input type="radio"/>
Encoder A-phase pulse (Differential line driver)	LA LAR	CN1-15 CN1-16	Outputs pulses per servo motor revolution set in parameter No. PA15 in the differential line driver system. In CCW rotation of the servo motor, the encoder B-phase pulse lags the encoder A-phase pulse by a phase angle of $\pi/2$.	DO-2	<input type="radio"/>	<input type="radio"/>
Encoder B-phase pulse (Differential line driver)	LB LBR	CN1-17 CN1-18	The relationships between rotation direction and phase difference of the A- and B-phase pulses can be changed using parameter No. PC13.			
Encoder Z-phase pulse (Differential line driver)	LZ LZR	CN1-19 CN1-20	The same signal as OP is output in the differential line driver system.	DO-2	<input type="radio"/>	<input type="radio"/>

(4) Power supply

Signal	Symbol	Connector pin No.	Functions/Applications	I/O division	Positioning mode	
					CP	CL
Digital I/F power supply input	DICOM	CN1-1	Used to input 24VDC (24VDC \pm 10% 200mA) for I/O interface. The power supply capacity changes depending on the number of I/O interface points to be used. For a sink interface, connect the positive terminal of the 24VDC external power supply to DICOM. For a source interface, connect the negative terminal of the 24VDC external power supply to DICOM.	/	<input type="radio"/>	<input type="radio"/>
Open collector power input	OPC	CN1-2	When inputting a pulse train in the open-collector system, supply this terminal with the positive (+) power of 24VDC.		<input type="radio"/>	<input type="radio"/>
Digital I/F common	DOCOM	CN1-13	Common terminal for input signals such as SON and EM1. Separated from LG. For a sink interface, connect the negative terminal of the 24VDC external power supply to DOCOM. For a source interface, connect the positive terminal of the 24VDC external power supply to DOCOM.		<input type="radio"/>	<input type="radio"/>
Control common	LG	CN1-14	Common terminal for OP.		<input type="radio"/>	<input type="radio"/>
Shield	SD	Plate	Connect the external conductor of the shielded wire.		<input type="radio"/>	<input type="radio"/>

13. POSITIONING MODE

13.2.4 Detailed description of the signals

(1) Forward rotation start, reverse rotation start, temporary stop/restart

- (a) A forward rotation start (ST1) or a reverse rotation start (ST2) should make the sequence which can be used after the main circuit has been established. These signals are invalid if it is switched on before the main circuit is established. Normally, it is interlocked with the ready (RD).
- (b) A start in the servo amplifier is made when a forward rotation start (ST1) or a reverse rotation start (ST2) changes from OFF to ON. The delay time of the servo amplifier's internal processing is max. 3ms. The delay time of other devices is max. 10ms.

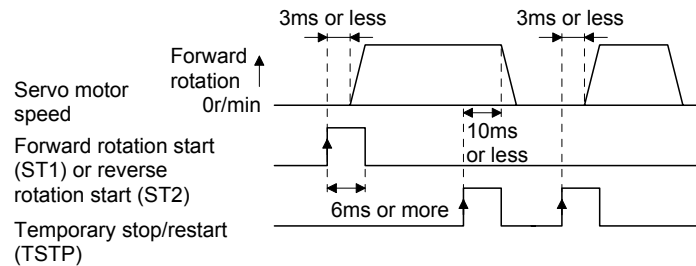

- (c) When a programmable controller is used, the ON time of a forward rotation start (ST1), a reverse rotation start (ST2) or temporary start/stop (TSTP) signal should be 6ms or longer to prevent a malfunction.
- (d) During operation, the forward rotation start (ST1) or reverse rotation start (ST2) is not accepted. The next operation should always be started after the rough match (CPO) is output with the rough match output range set to "0" or after the travel completion (MEND) is output.

13. POSITIONING MODE

(2) Travel completion, rough match, in-position

POINT
<ul style="list-style-type: none"> If an alarm cause, etc. are removed and servo-on occurs after a stop is made by servo-off, alarm occurrence or forced stop (EM1) ON during automatic operation, travel completion (MEND), rough-match, (CPO) and in-position (INP) are turned on. To resume operation, confirm the current position and the selected point table No. and program No. for preventing unexpected operation.

(a) Travel completion

The following timing charts show the output timing relationships between the position command generated in the servo amplifier and the travel completion (MEND). This timing can be changed using parameter No. PA10 (in-position range). MEND turns ON in the servo-on status. MEND does not turn ON during automatic operation.

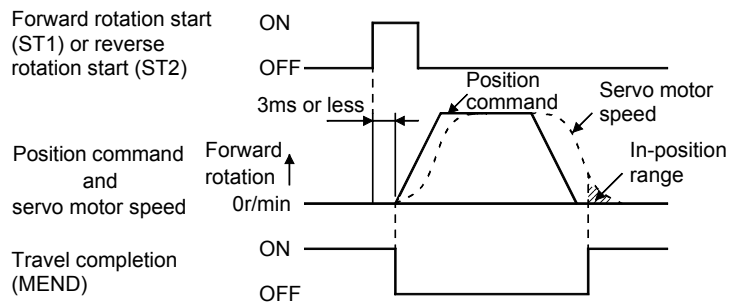

When parameter No. PA10 is small

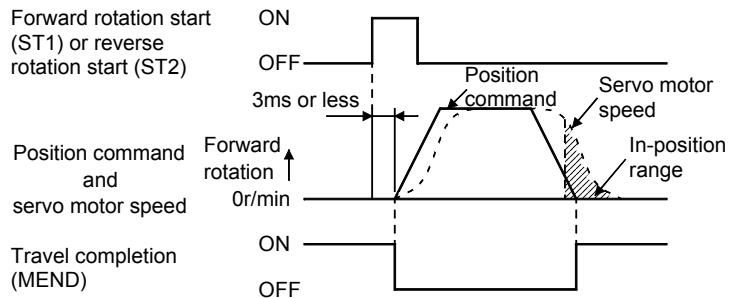

When parameter No. PA10 is large

13. POSITIONING MODE

(b) Rough match

The following timing charts show the relationships between the signal and the position command generated in the servo amplifier. This timing can be changed using parameter No. PE12 (rough match output range). CPO turns ON in the servo-on status. CPO does not turn ON during automatic operation.

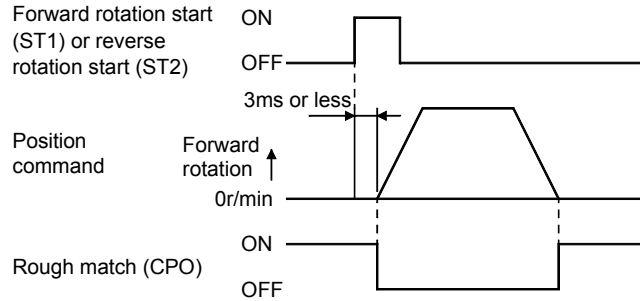

When parameter No. PE12 is set to "0"

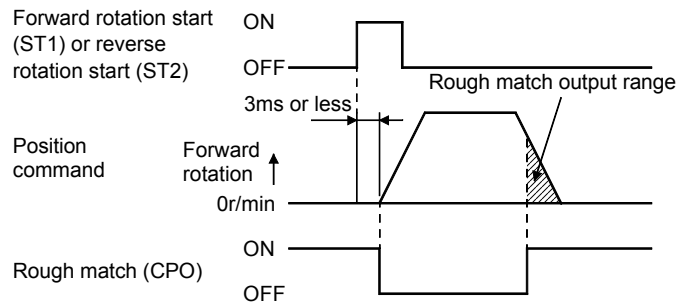

When parameter No. PE12 is set to more than "0"

13. POSITIONING MODE

(3) In-position

The following timing charts show the relationships between the signal and the feedback pulse of the servo motor. This timing can be changed using parameter No.PA10 (in-position range). INP turns ON in the servo-on status.

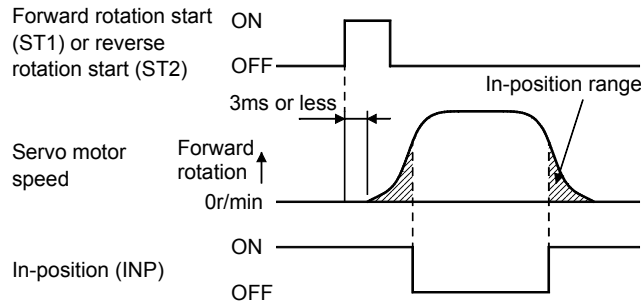

When positioning operation is performed once

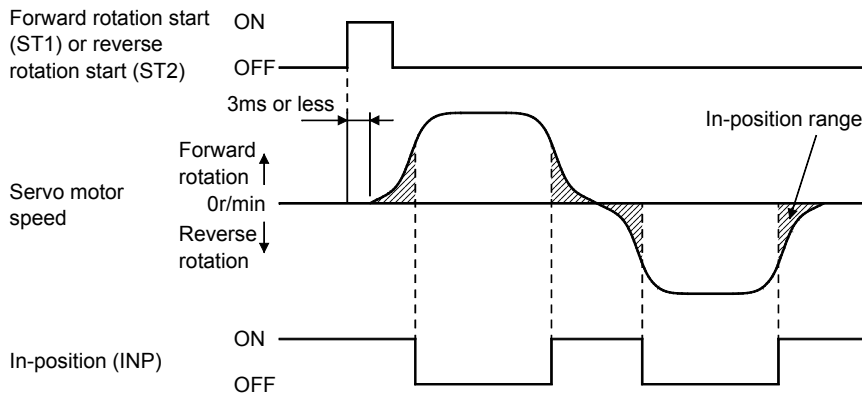

When servo motor reverses rotation direction during automatic continuous operation

13. POSITIONING MODE

13.3 Automatic operation mode for point table method

13.3.1 What is automatic operation mode?

(1) Concept of automatic operation

Automatic operation is a positioning function to automatically start and stop at a target position with one-time start signal. The data required for positioning is set in the point table.

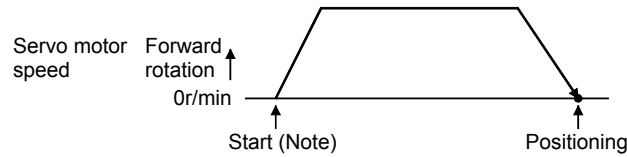

Note. For the start, use the forward rotation start (ST1) or reverse rotation start (ST2).

(2) Automatic operation types

With this servo, the following automatic operations are available.

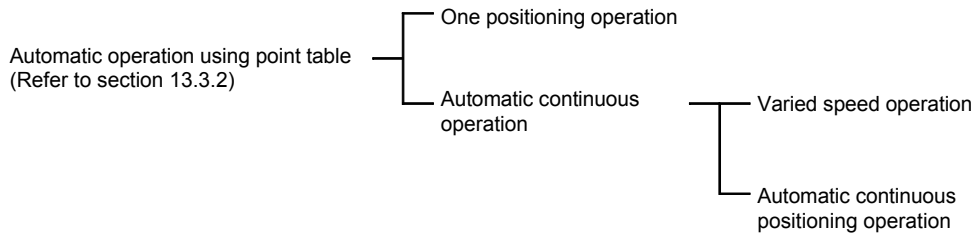

There are two types of command systems; the absolute value command system which requires specifying the positioning addresses to move to for each automatic operation and the incremental value command system which requires specifying the travel distance from the current position to the target position.

13. POSITIONING MODE

(3) Command system

Make selection with the input signals from among the point tables that have been set in advance, and perform operation with Forward rotation start (ST1) or Reverse rotation start (ST2). Automatic operation has the absolute value command system and incremental value command system.

(a) Absolute value command system

As position data, set the target address to be reached.

Setting range: -999999 to 999999 [$\times 10^{\text{STM}} \mu\text{m}$] (STM = feed length multiplication parameter No. PE02)

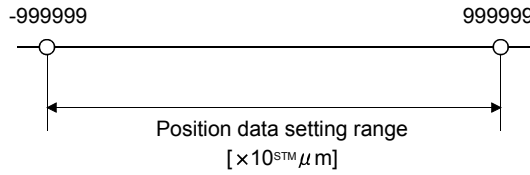

(b) Incremental value command system

As position data, set the travel distance from the current address to the target address.

Setting range: 0 to $999999 \times 10^{\text{STM}} \mu\text{m}$ (STM = feed length multiplication parameter No. PE02)

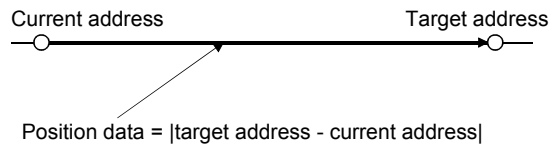

13. POSITIONING MODE

13.3.2 Automatic operation using point table

(1) One-time positioning operation

(a) Absolute value command system

1) Point table

Set the point table values by using MR Configurator or the operation section.

Set the position data, servo motor speed, acceleration time constant, deceleration time constant, dwell and auxiliary function in the point table.

Setting "0" or "1" in the auxiliary function sets the point table to the absolute value command system.

Setting "2" or "3" in the auxiliary function sets the point table to the incremental value command system.

Item	Setting range	Unit	Description
Position data	-999999 to 999999	$\times 10^{\text{STM}} \mu\text{m}$	(1) When using this point table as absolute value command system, set the target address (absolute value). (2) When using this point table as incremental value command system, set the travel distance. A "-" sign indicates a reverse rotation command.
Servo motor speed	0 to permissible speed	r/min	Set the command speed of the servo motor for execution of positioning. The setting should be equal to or less than the instantaneous permissible speed of the servo motor.
Acceleration time constant	0 to 20000	ms	Set the time until the servo motor reaches to the rated speed.
Deceleration time constant	0 to 20000	ms	Set the time until the servo motor stops from the rated speed.
Dwell	0 to 20000	ms	When dwell is set and the set dwell has passed after the position command of the selected point table is completed, the position command of the next point table is started. Set "0" in the auxiliary function to make the dwell invalid. Set "1" in the auxiliary function and 0 in the dwell to perform varied speed operation.
Auxiliary function	0 to 3		(1) When using this point table in the absolute value command system 0: Automatic operation is performed in accordance with a single point table chosen. 1: Operation is performed in accordance with consecutive point tables without a stop. (2) When using this point table in the incremental value command system 2: Automatic operation is performed in accordance with a single point table chosen. 3: Operation is performed in accordance with consecutive point tables without a stop. When a different rotation direction is set, smoothing zero (command output) is confirmed and the rotation direction is then reversed. Setting "1" in point table No. 7 results in an error. (Refer to paragraph (2) of this section.)

13. POSITIONING MODE

2) Parameter setting

Set the following parameters to perform automatic operation.

Select the absolute value command system with parameter No. PE01 (Command mode selection).

Parameter No. PE01

			0
--	--	--	---

└ Absolute value command system (initial value)

By using parameter No. PA14 (Rotation direction selection), select servo motor rotation direction at the time when the forward rotation start (ST1) turns ON.

Parameter No. PA14 setting	Servo motor rotation direction when forward rotation start (ST1) turns on
0	CCW rotation with + position data CW rotation with - position data
1	CW rotation with + position data CCW rotation with - position data

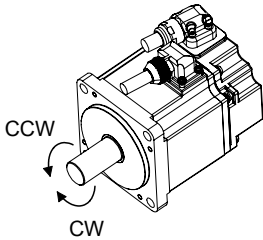

Set the feed length multiplication (STM) of position data in parameter No. PE02 (Feeding function selection).

Parameter No. PE02 setting	Feed unit [μm]	Position data input range [mm]
□□□0	1	-999.999 to +999.999
□□□1	10	-9999.99 to +9999.99
□□□2	100	-99999.9 to +99999.9
□□□3	1000	-999999 to +999999

3) Operation

Choosing the point table using DI0 to DI2 and turning ST1 ON starts positioning to the position data at the preset speed, acceleration time constant and deceleration time constant. At this time, reverse rotation start (ST2) is invalid.

Item	Device/Parameter used	Description
Automatic operation mode selection	Automatic/manual selection (MD0)	Turn MD0 ON.
Point table selection	Point table No./Program No. selection 1 (DI0) Point table No./Program No. selection 2 (DI1) Point table No./Program No. selection 3 (DI2)	Refer to the text.
Start	Forward rotation start (ST1)	Turn ST1 ON to start.

13. POSITIONING MODE

Select a point table using the point table No./program No. selection 1 (DI0) to point table No./program No. selection 3 (DI2) as shown in the following table.

Input device			Selected point table No.
DI2	DI1	DI0	
0	0	1	1
0	1	0	2
0	1	1	3
1	0	0	4
1	0	1	5
1	1	0	6
1	1	1	7

(b) Incremental value command system

1) Point table

Set the point table values by using MR Configurator or the operation section.

Set the position data, servo motor speed, acceleration time constant, deceleration time constant, dwell and auxiliary function in the point table.

Item	Setting range	Unit	Description
Position data	0 to 999999	$\times 10^{\text{STM}} \mu\text{m}$	Set the travel distance. The unit can be changed using feed length multiplication selection of parameter No. PE02.
Servo motor speed	0 to permissible speed	r/min	Set the command speed of the servo motor for execution of positioning. The setting should be equal to or less than the instantaneous permissible speed of the servo motor.
Acceleration time constant	0 to 20000	ms	Set the time until the servo motor reaches to the rated speed.
Deceleration time constant	0 to 20000	ms	Set the time until stops from the rated speed.
Dwell	0 to 20000	ms	When dwell is set and the set dwell has passed after the position command of the selected point table is completed, the position command of the next point table is started. Set "0" in the auxiliary function to make the dwell invalid. Set "1" in the auxiliary function and 0 in the dwell to perform varied speed operation.
Auxiliary function	0, 1		0: Automatic operation is performed in accordance with a single point table chosen. 1: Operation is performed in accordance with consecutive point tables without a stop. When a different rotation direction is set, smoothing zero (command output) is confirmed and the rotation direction is then reversed. Setting "1" in point table No. 7 results in an error. (Refer to (2) in this section.)

13. POSITIONING MODE

2) Parameter setting

Set the following parameters to perform automatic operation.

Select the incremental value command system with parameter No. PE01 (command mode selection) as shown below.

Parameter No. PE01

			1
--	--	--	---

└ Incremental value command system

By using parameter No. PA14 (Rotation direction selection), select servo motor rotation direction at the time when the forward rotation start (ST1) or reverse rotation start (ST2) is turns ON.

Parameter No. PA14 setting	Servo motor rotation direction	
	Forward rotation start (ST1) ON	Reverse rotation start (ST2) ON
0	CCW rotation (address incremented)	CW rotation (address decremented)
1	CW rotation (address incremented)	CCW rotation (address decremented)

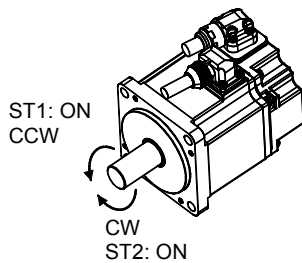

Parameter No. PA14: 0

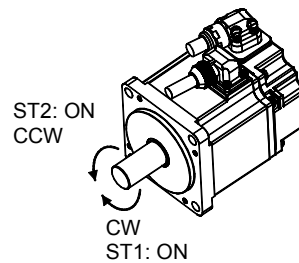

Parameter No. PA14: 1

Set the feed length multiplication (STM) of position data with parameter No. PE02 (Feeding function selection).

Parameter No. PE02 setting	Feed unit [μm]	Position data input range [mm]
□□□0	1	0 to +999.999
□□□1	10	0 to +9999.99
□□□2	100	0 to +99999.9
□□□3	1000	0 to +999999

13. POSITIONING MODE

3) Operation

Choosing the point table using DI0 to DI2 and turning ST1 ON starts a motion in the forward rotation direction over the travel distance of the position data at the preset speed and acceleration time constant.

Turning ST2 ON starts a motion in the reverse rotation direction according to the values set to the selected point table.

Item	Device/Parameter used	Description
Automatic operation mode selection	Automatic/manual selection (MD0)	Turn MD0 ON.
Point table selection	Point table No./Program No. selection 1 (DI0) Point table No./Program No. selection 2 (DI1) Point table No./Program No. selection 3 (DI2)	Refer to (1) (a) 3) in this section.
Start	Forward rotation start (ST1) Reverse rotation start (ST2)	Turn ST1 ON to start motion in forward rotation direction. Turn ST2 ON to start motion in reverse rotation direction.

(c) Automatic operation timing chart

The timing chart is shown below.

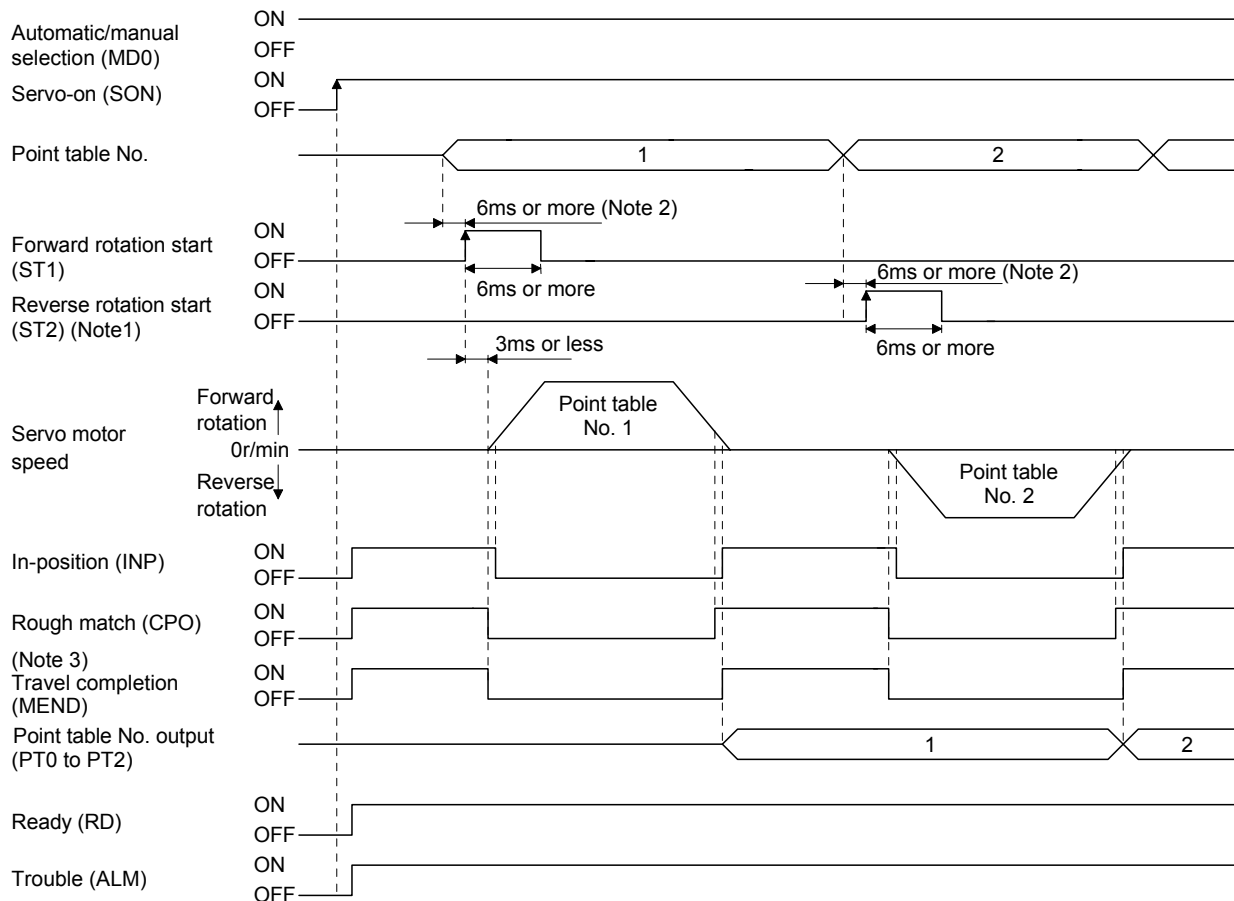

Note 1. Reverse rotation start (ST2) is invalid in the absolute value command system.

2. External input signal detection delays by the input filter setting time of parameter No. PD19. Additionally, make up a sequence that changes the point table selection ahead of time by considering delays in output signal sequence from the controller and variations of a signal change due to hardware.

3. If the over load tough drive function is enabled by setting parameter No. PA04 to "□□ 1", INP turn-on delays during the overload tough drive. MEND turn-on also delays together with INP.

13. POSITIONING MODE

(2) Automatic continuous operation

(a) What is Automatic continuous operation?

By merely choosing one point table and turning ON the forward rotation start (ST1) or the reverse rotation start (ST2), operation can be performed in accordance with the point tables having consecutive numbers.

Automatic continuous operation is available in two types: varied speed operation and automatic continuous positioning operation.

Either type may be selected as follows.

1) In absolute value command system

Automatic continuous operation { Varied speed operation
Automatic continuous positioning operation

Point table setting		
Dwell	Auxiliary function	
	When position data is in absolute value	When position data is in incremental value
0	1	3
1 or more	1	3

2) In incremental value command system

Automatic continuous operation { Varied speed operation
Automatic continuous positioning operation

Point table setting	
Dwell	Auxiliary function
0	1
1 or more	1

(b) Varied speed operation

When "1" or "3" is set to the auxiliary function in the point tables up to No.6, varied speed operation can be performed at a maximum of 7 speeds. Set "0" to the auxiliary function in the last point table.

When performing varied speed operation, always set "0" to the dwell. If "1" or more is set, automatic continuous positioning operation is made valid.

The following table gives a setting example.

Point table No.	Dwell [ms] (Note 1)	Auxiliary function	Variable speed operation
1	0	1	Consecutive point table data
2	0	1	
3	0	0 (Note 2)	
4	0	1	Consecutive point table data
5	0	1	
6	0	1	
7	0	0 (Note 2)	

Note 1. Always set "0".

2. Always set "0" or "2" to the auxiliary function in the last point table among the consecutive point tables.

13. POSITIONING MODE

1) Absolute value command system

This system is an auxiliary function for point tables to perform automatic continuous operation by specifying the absolute value command or incremental value command.

• Positioning in single direction

The operation pattern given below assumes that the setting values are as indicated in the following table. Here, the point table No.1 uses the absolute value command system, the point table No.2 the incremental value command system, the point table No.3 the absolute value command system, and the point table No.4 the incremental value command system.

Point table No.	Position data [$\times 10^{\text{STM}}$ μm]	Servo motor speed [r/min]	Acceleration time constant [ms]	Deceleration time constant [ms]	(Note 1) Dwell [ms]	Auxiliary function
1	5.00	3000	100	150	0	1
2	3.00	2000	Invalid	Invalid	0	3
3	10.00	1000	Invalid	Invalid	0	1
4	6.00	500	Invalid	Invalid	0	2 (Note 2)

Note 1. Always set "0".

2. Always set "0" or "2" to the auxiliary function in the last point table among the consecutive point tables.

0: When point table is used in absolute value command system

2: When point table is used in incremental value command system

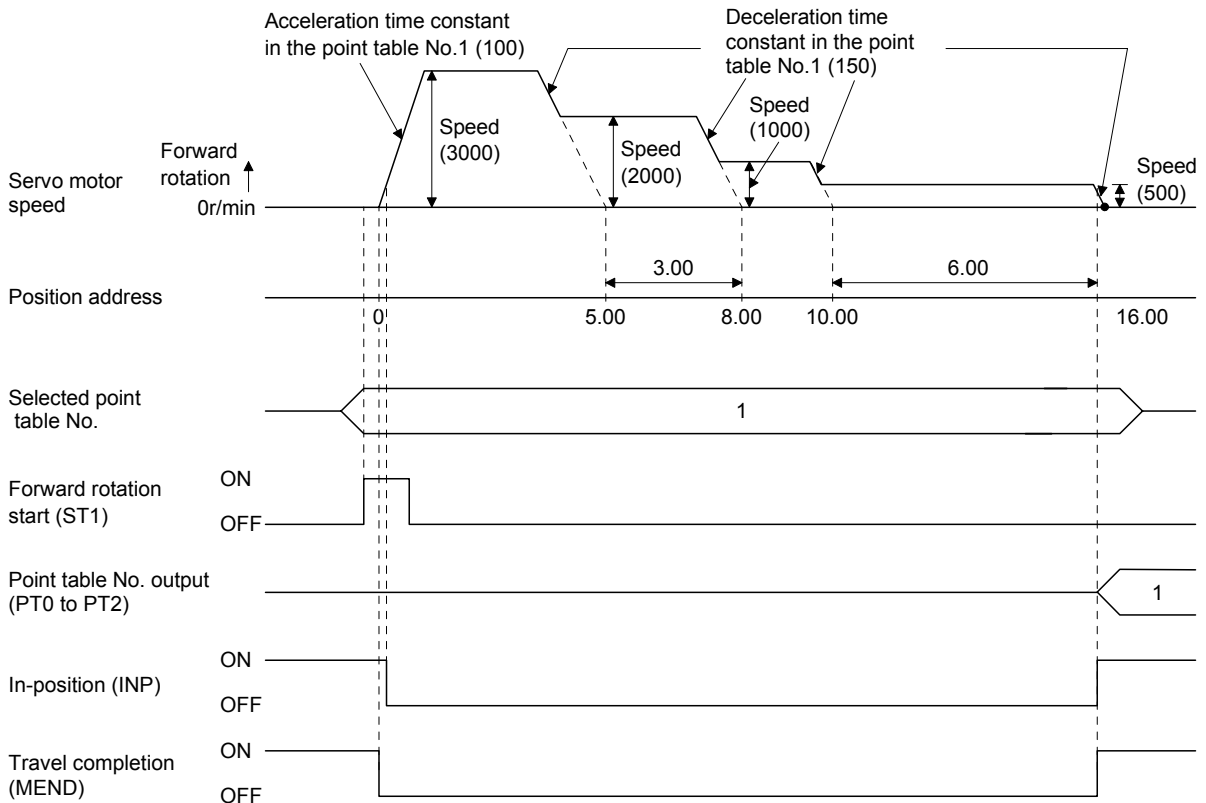

13. POSITIONING MODE

• Positioning that reverses the direction midway

The operation pattern given below assumes that the setting values are as indicated in the following table. Here, the point table No.1 uses the absolute value command system, the point table No.2 the incremental value command system, and the point table No.3 the absolute value system.

Point table No.	Position data [$\times 10^{\text{STM}}$ μm]	Servo motor speed [r/min]	Acceleration time constant [ms]	Deceleration time constant [ms]	(Note 1) Dwell [ms]	Auxiliary function
1	5.00	3000	100	150	0	1
2	7.00	2000	Invalid	Invalid	0	3
3	8.00	1000	Invalid	Invalid	0	0 (Note 2)

Note 1. Always set "0".

2. Always set "0" or "2" to the auxiliary function in the last point table among the consecutive point tables.

0: When point table is used in absolute value command system

2: When point table is used in incremental value command system

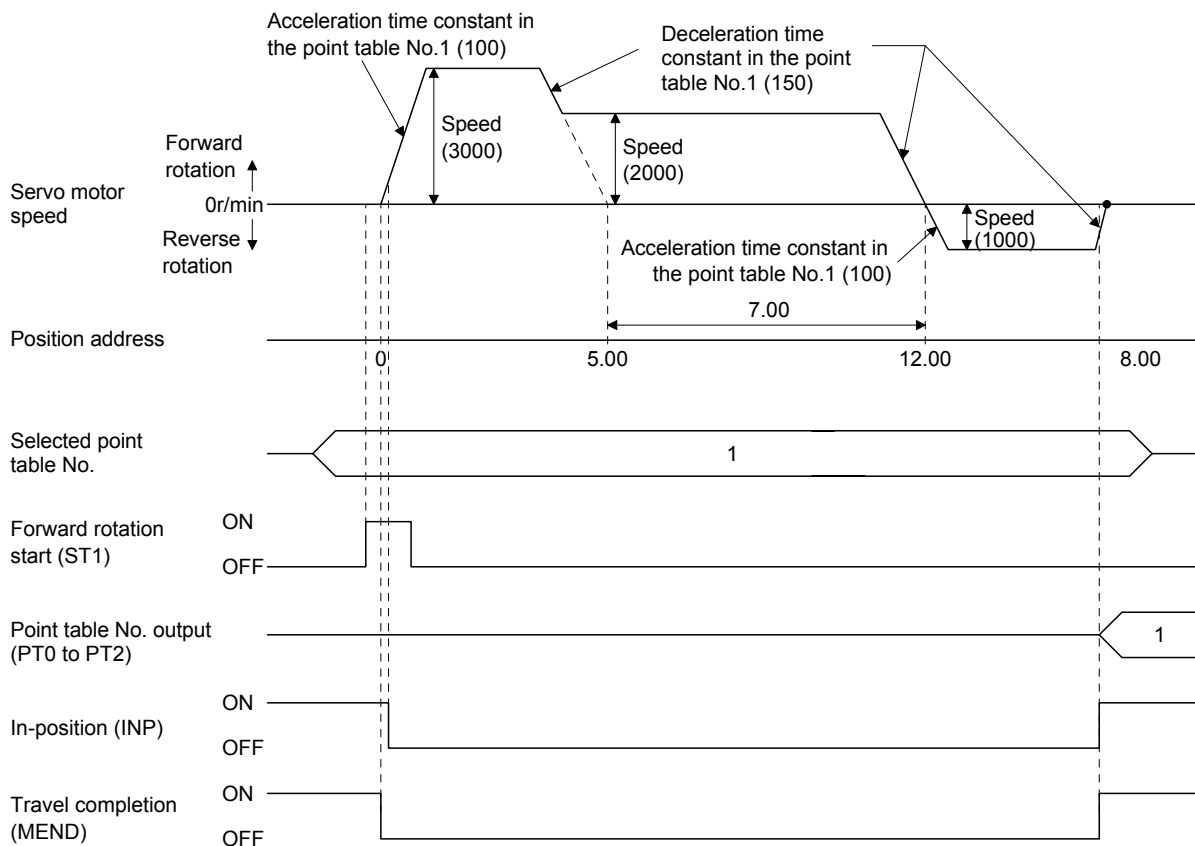

13. POSITIONING MODE

2) Incremental value command system

The position data of the incremental value command system is the sum of the position data of the consecutive point tables.

The operation pattern given below assumes that the setting values are as indicated in the following table.

Point table No.	Position data [$\times 10^{\text{STM}}$ μm]	Servo motor speed [r/min]	Acceleration time constant [ms]	Deceleration time constant [ms]	(Note 1) Dwell [ms]	Auxiliary function
1	5.00	3000	100	150	0	1
2	6.00	2000	Invalid	Invalid	0	1
3	3.00	1000	Invalid	Invalid	0	0 (Note 2)

Note 1. Always set "0".

2. Always set "0" to the auxiliary function in the last point table among the consecutive point tables.

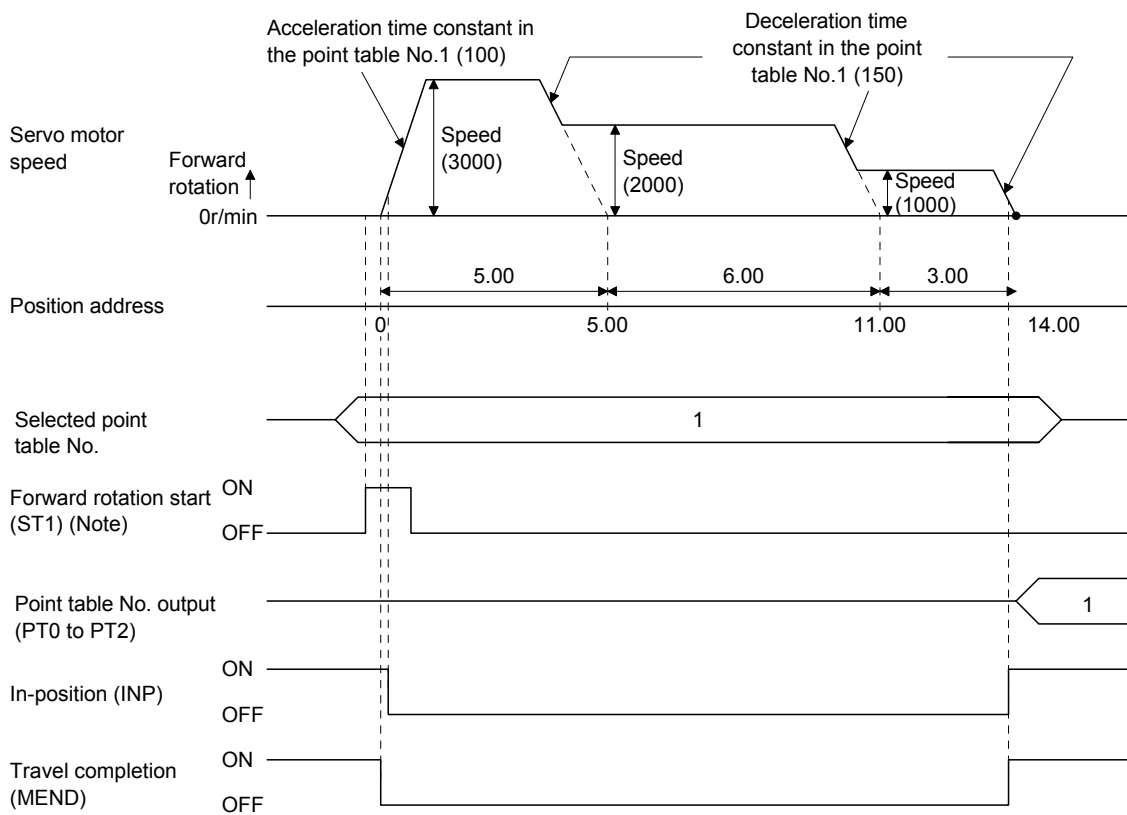

Note. Turning on reverse rotation start (ST2) starts positioning in the reverse rotation direction.

13. POSITIONING MODE

(c) Automatic continuous positioning operation

When "1" or "3" is set to the auxiliary function in the point table, positioning of the next point table No. is executed continuously.

When "1" or "3" is set to the auxiliary function in the point tables up to No.6, a maximum of 7 points of automatic continuous positionings are possible. Set "0" to the auxiliary function in the last point table.

As an example, the operation in the absolute value command system is shown using the set values in the following table. Here, the point table No.1 uses the absolute value command system, the point table No.2 the incremental value command system, and the point table No.3 the absolute value command system.

Point table No.	Position data [$\times 10^{\text{STM}} \mu\text{m}$]	Servo motor speed [r/min]	Acceleration time constant [ms]	Deceleration time constant [ms]	Dwell [ms]	Auxiliary function
1	5.00	3000	100	150	100	1
2	-6.00	2000	100	100	0	3
3	3.00	3000	50	50	0	0 (Note)

Note. Always set "0" or "2" to the auxiliary function in the last point table among the consecutive point tables.

0: When point table is used in absolute value command system

2: When point table is used in incremental value command system

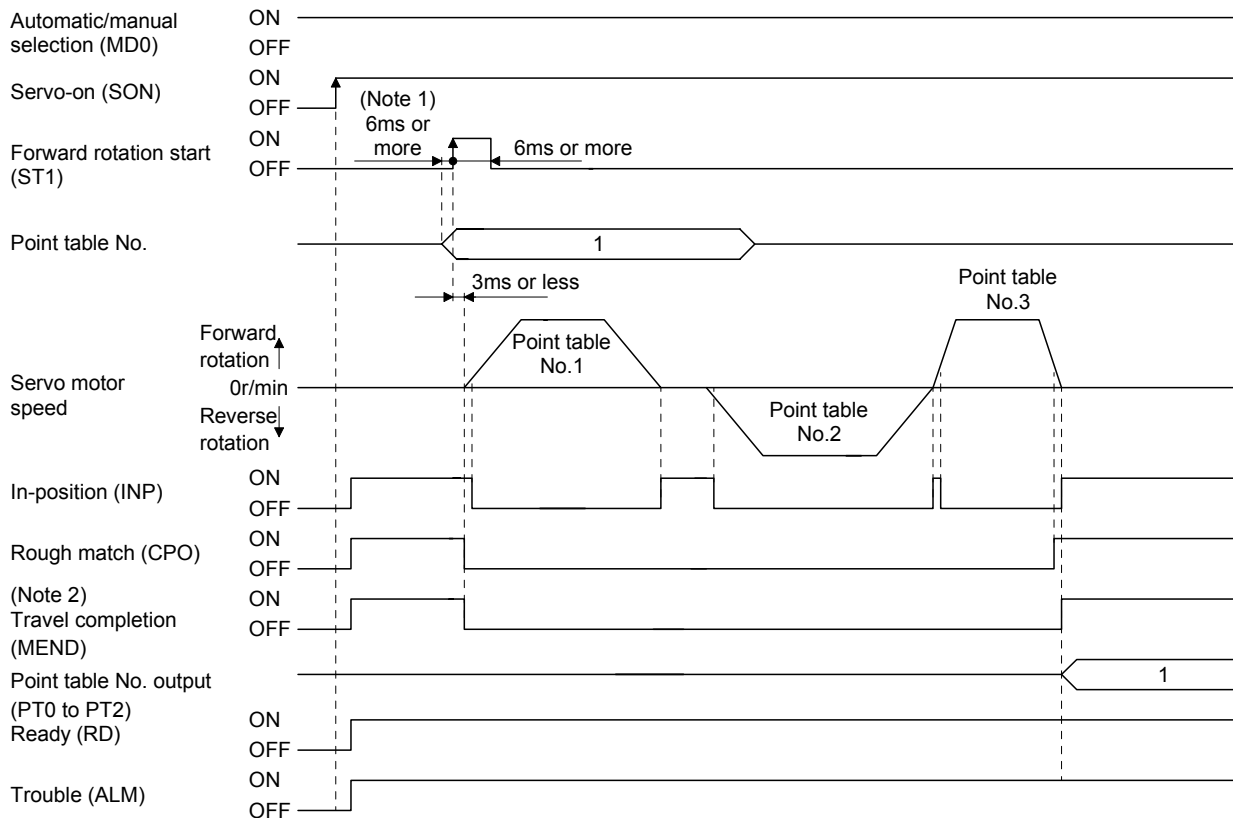

Note 1. External input signal detection delays by the input filter setting time of parameter No. PD19. Additionally, make up a sequence that changes the point table selection ahead of time by considering delays in output signal sequence from the controller and variations of a signal change due to hardware.

2. If the over load tough drive function is enabled by setting parameter No. PA04 to "□□ 1", INP turn-on delays during the overload tough drive. MEND turn-on also delays together with INP. However, MEND does not turn ON during automatic continuous positioning operation.

13. POSITIONING MODE

(3) Temporary stop/restart during automatic operation

When TSTP is turned ON during automatic operation, the motor is decelerated to a temporary stop at the deceleration time constant in the point table being executed. When TSTP is turned ON again, the remaining distance is executed.

Forward rotation start (ST1) or reverse rotation start (ST2) is ignored if it is turned ON during a temporary stop.

The remaining moving distance is cleared when the operation mode is changed from the automatic mode to the manual mode during a temporary stop.

The temporary stop/restart input is ignored during a home position return or during JOG operation.

(a) When the servo motor is rotating

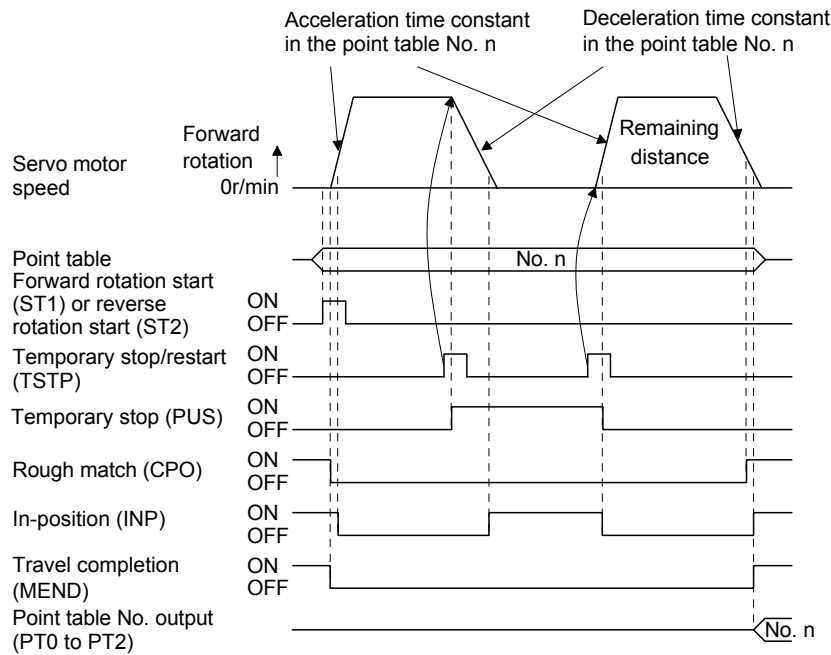

(b) During dwell

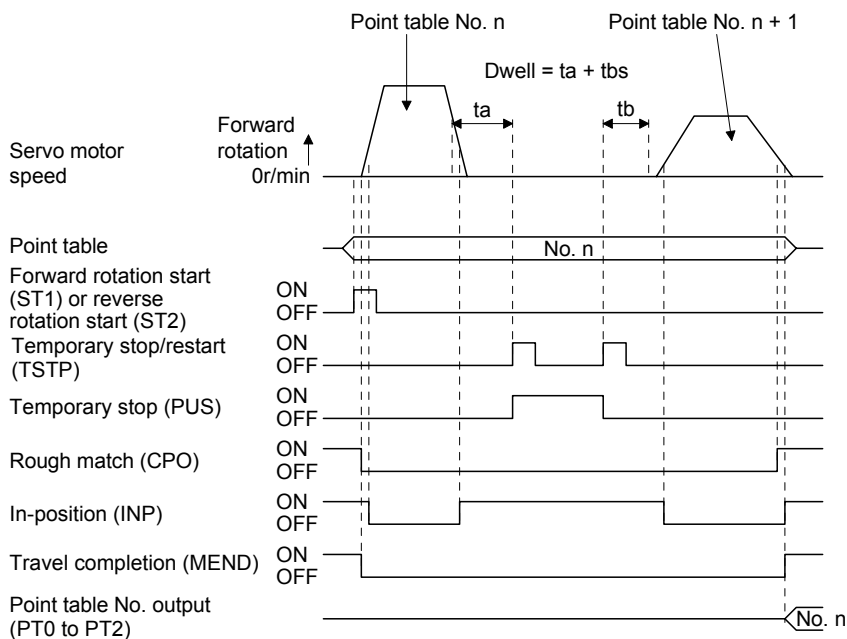

13. POSITIONING MODE

13.4 Automatic operation mode for program method

13.4.1 What is automatic operation mode for program method?

Make selection with the input signals from among the programs that have been created in advance using MR Configurator, and perform operation with Forward rotation start (ST1).

This servo amplifier is factory-set to the absolute value command system.

As the position data, the absolute move command ("MOV" command) used to specify the target address or the incremental move command ("MOVI" command) used to specify the travel distance can be set. Note that the movable range is -999999 to 999999 [$\times 10^{\text{STM}} \mu\text{m}$]. Positioning is enabled within this range.

Setting range: -999999 to 999999 [$\times 10^{\text{STM}} \mu\text{m}$] (STM = feed length multiplication parameter No. PE02)

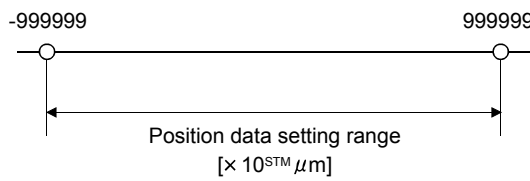

13. POSITIONING MODE

13.4.2 Programming language

The maximum number of program steps is 120. Though up to 8 programs can be created, the total number of each program steps is up to 120.

The set program can be selected using point table No./program No. selection 1 (DI0) to point table No./program No. selection 3 (DI2).

(1) Command list

Command	Name	Setting	Setting range	Unit	Indirect addressing	Description
SPN (Note 2)	Speed (Motor speed)	SPN (Setting value)	0 to instantaneous permissible speed	r/min	<input type="radio"/>	Used to set the command speed of the servo motor for positioning. The set value should be equal to or less than the instantaneous permissible speed of the servo motor.
STA (Note 2)	Acceleration time constant	STA (Setting value)	0 to 20000	ms	<input type="radio"/>	Used to set the acceleration time constant. The set value is the time in which the servo motor reaches the rated speed from a stop. It cannot be changed during command output.
STB (Note 2)	Deceleration time constant	STB (Setting value)	0 to 20000	ms	<input type="radio"/>	Used to set the deceleration time constant. The set value is the time in which the servo motor stops from the rated speed. It cannot be changed during command output.
STC (Note 2)	Acceleration/ deceleration time constant	STC (Setting value)	0 to 20000	ms	<input type="radio"/>	Used to set the acceleration/deceleration time constants. The set value is the time in which the servo motor reaches the rated speed from a stop or stops from the rated speed. When this command is used, the acceleration time constant and deceleration time constant are equal. "STA" and "STB" commands can set the acceleration time constant and deceleration time constant individually. It cannot be changed during command output.
STD (Note 2, 5)	S-pattern acceleration/deceleration time constant	STD (Setting value)	0 to 100	ms	<input type="radio"/>	Used to set the S-pattern acceleration/deceleration time constant. Set this command when inserting an S-pattern acceleration/deceleration time constant for the acceleration/deceleration time constant of the program.
MOV	Absolute move command	MOV (Setting value)	-999999 to 999999	$\times 10^{\text{STM}} \mu\text{m}$	<input type="radio"/>	The set value is regarded as an absolute value for movement.
MOVA	Absolute continuous move command	MOVA (Setting value)	-999999 to 999999	$\times 10^{\text{STM}} \mu\text{m}$	<input type="radio"/>	The set value is regarded as an absolute value for continuous movement. Always use this command with the "MOV" command.
MOVI	Incremental move command	MOVI (Setting value)	-999999 to 999999	$\times 10^{\text{STM}} \mu\text{m}$	<input type="radio"/>	The set value is regarded as an incremental value for movement.
MOVIA	Incremental continuous move command	MOVIA (Setting value)	-999999 to 999999	$\times 10^{\text{STM}} \mu\text{m}$	<input type="radio"/>	The set value is regarded as an incremental value for movement. Always use this command with the "MOVI" command.

13. POSITIONING MODE

Command	Name	Setting	Setting range	Unit	Indirect addressing	Description
SYNC (Note 1)	Waiting external signal to switch on	SYNC (Setting value)	1			Stops the next step until program input 1 (PI1) turns ON after the output of SYNC synchronous output (SOUT).
OUTON (Note 1, 3)	External signal ON output	OUTON (Setting value)	1			Turns ON program output 1 (OUT1). By setting the ON time with parameter No. PE14, the signal can also be turned OFF in the preset time.
OUTOF (Note 1)	External signal OFF output	OUTOF (Setting value)	1			Turns OFF program output 1 (OUT1) to that has been turned ON by the "OUTON" command.
TRIP (Note 1)	Absolute trip point	TRIP (Setting value)	-999999 to 999999	$\times 10^{\text{STM}} \mu\text{m}$		When the trip point is reached, the next step will be executed.
TRIP1 (Note 1)	Incremental trip point	TRIP1 (Setting value)	-999999 to 999999	$\times 10^{\text{STM}} \mu\text{m}$		Executes the next step when the travel distance set to the "TRIP1" command is traveled from when "MOVI" and "MOVIA" started during the movement executed by the "MOV" and "MOVIA" commands. The command should be programmed after "MOVI" and "MOVIA" command, otherwise program error occurs.
ITP (Note 1, 4)	Interrupt positioning command	ITP (Setting value)	0 to 999999	$\times 10^{\text{STM}} \mu\text{m}$		Makes a stop using the interrupt signal when the preset travel distance is reached. Use this command in combination with the "SYNC" command, and describe it after "SYNC". An error will occur if this command is described after any other command.
COUNT (Note 1)	External pulse counter	COUNT (Setting value)	-999999 to 999999	pulse		Executes the next step when the pulse counter value becomes greater than the count value set to the "COUNT" command. "COUNT (0)" clears the pulse counter.
FOR NEXT	Step repeat command	FOR (Setting value) NEXT	0, 1 to 10000	times		Repeats the steps located between the "FOR (setting value)" command and "NEXT" command by the preset number of times. Set "0" to select endless repetition.
TIM	Dwell command time	TIM (Setting value)	1 to 20000	ms	○	Holds the next step until the preset time elapses.
ZRT	Zeroing	ZRT				Executes a home position return.
TIMES	Program repeat command	TIMES (Setting value)	0, 1 to 10000	times	○	Place the "TIMES (setting value)" command at the beginning of the program and set the number of program execution times. When executing the program only once, this setting is not required. Set "0" to select endless repetition.
STOP	Program end	STOP				Stops the executing program. Always describe this command on the last line.

Note 1. "SYNC", "OUTON", "OUTOF", "TRIP", "TRIP1", "COUNT" and "ITP" commands are available to be validated during command outputting.

- The "SPN" command is valid when the "MOV", "MOVA", "MOVI" or "MOVIA" command is executed. The "STA", "STB", "STC" and "STD" commands are valid when the "MOV" or "MOVI" command is executed.
- When the ON time has been set in parameter No. PE14, the next command is executed after the preset time has elapsed.
- The remaining moving distance by "ITP" command is lower than setting value, the command would be ignored and skip to the next program command.
- S-pattern acceleration/deceleration time constant of this command is valid during the time from this command start to the program end. For other than that, S-pattern acceleration/deceleration time constant of parameter No. PC03 is valid.

13. POSITIONING MODE

(2) Detailed description of commands

(a) Positioning conditions (SPN, STA, STB, STC, STD)

The "SPN", "STA", "STB", "STC" and "STD" commands are valid when the "MOV" and "MOVA" commands are executed. The set values remain valid until they are reset.

1) Program example 1

When operation is to be performed in two patterns that have the same servo motor speed, acceleration time constant and deceleration time constant but different move commands.

Program	Description		
SPN(1000)	Speed (Motor speed)	1000[r/min]	a)
STA(200)	Acceleration time constant	200[ms]	b)
STB(300)	Deceleration time constant	300[ms]	c)
MOV(1000)	Absolute move command	1000[×10 ^{STM} μm]	d)
TIM(100)	Dwell command time	100[ms]	e)
MOV(2000)	Absolute move command	2000[×10 ^{STM} μm]	f)
STOP	Program end		

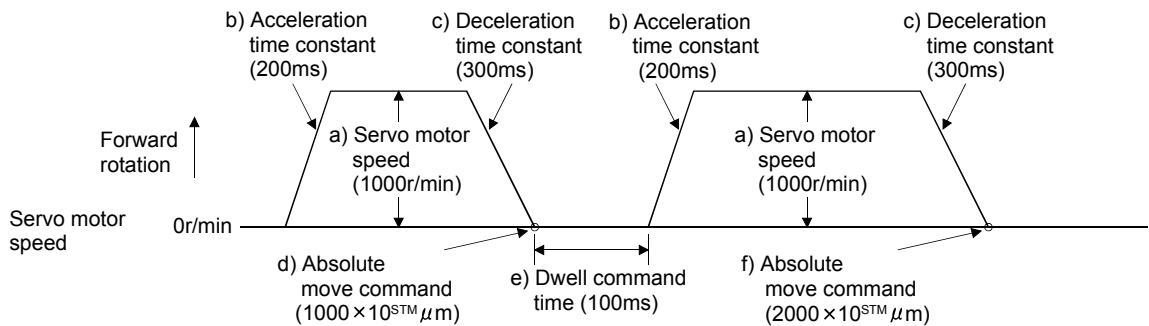

2) Program example 2

When operation is to be performed in two patterns that have different servo motor speeds, acceleration time constants, deceleration time constants and move commands.

Program	Description		
SPN(1000)	Speed (Motor speed)	1000[r/min]	a)
STA(200)	Acceleration time constant	200[ms]	b)
STB(300)	Deceleration time constant	300[ms]	c)
MOV(1000)	Absolute move command	1000[×10 ^{STM} μm]	d)
TIM(100)	Dwell command time	100[ms]	e)
SPN(500)	Speed (Motor Speed)	500[r/min]	f)
STC(200)	Acceleration/deceleration time constant	200[ms]	g)
MOV(1500)	Absolute move command	1500[×10 ^{STM} μm]	h)
STOP	Program end		

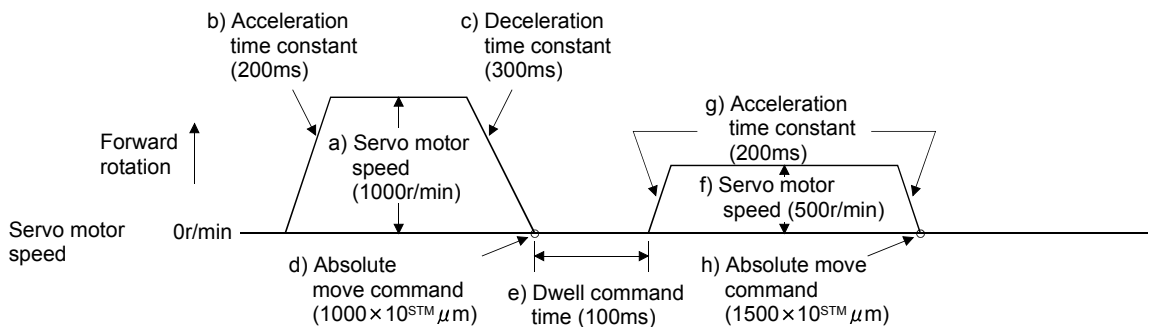

13. POSITIONING MODE

3) Program example 3

Use of an S-pattern acceleration/deceleration time constant allows sudden operation to be eased at the time of acceleration/deceleration. When the "STD" command is used, parameter No. PC03 (S-pattern acceleration/deceleration time constant) is ignored.

Program	Description		
SPN(1000)	Speed (Motor speed)	1000[r/min]	a)
STC(100)	Acceleration/deceleration time constant	1000[ms]	b)
STD(10)	S-pattern acceleration/deceleration time constant	10[ms]	c)
MOV(2000)	Absolute move command	2000[×10 ^{STM} μm]	d)
STOP	Program end		

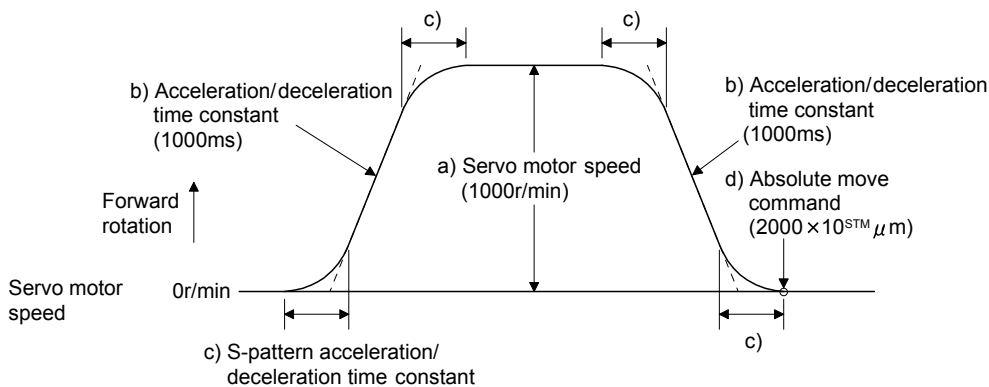

(b) Continuous move command (MOVA, MOVIA)

POINT
<ul style="list-style-type: none"> "MOV" cannot be used with "MOVIA", and "MOVI" cannot be used with "MOVA".

The "MOVA" command is a continuous move command for the "MOV" command. After execution of the movement by the "MOV" command, the movement of the "MOVA" command can be executed continuously without a stop.

The speed changing point of the "MOVA" command is the deceleration starting position of the operation performed by the preceding "MOV" and "MOVA" commands.

The acceleration/deceleration time constant of the "MOVA" command is the value at execution of the preceding "MOV" command.

The "MOVIA" command is a continuous move command for the "MOVI" command. After execution of the movement by the "MOVI" command, the movement of the "MOVIA" command can be executed continuously without a stop.

The speed changing point of the "MOVIA" command is the deceleration starting position of the operation performed by the preceding "MOVI" and "MOVIA" commands.

The acceleration/deceleration time constant of the "MOVIA" command is the value at execution of the preceding "MOVI" command.

Command	Name	Setting	Unit	Description
MOV	Absolute move command	MOV (Setting value)	×10 ^{STM} μm	Absolute move command
MOVA	Absolute continuous move command	MOVA (Setting value)	×10 ^{STM} μm	Absolute continuous move command
MOVI	Incremental move command	MOVI (Setting value)	×10 ^{STM} μm	Incremental move command
MOVIA	Incremental continuous move command	MOVIA (Setting value)	×10 ^{STM} μm	Incremental continuous move command

13. POSITIONING MODE

1) Program example 1

For the absolute move command in the absolute value command system

Program	Description		
SPN(500)	Speed (Motor speed)	500[r/min]	a)
STA(200)	Acceleration time constant	200[ms]	b)
STB(300)	Deceleration time constant	300[ms]	c)
MOV(500)	Absolute move command	$500[\times 10^{STM} \mu m]$	d)
SPN(1000)	Speed (Motor speed)	1000[r/min]	e)
MOVA(1000)	Absolute continuous move command	$1000[\times 10^{STM} \mu m]$	f)
MOVA(0)	Absolute continuous move command	$0[\times 10^{STM} \mu m]$	g)
STOP	Program end		

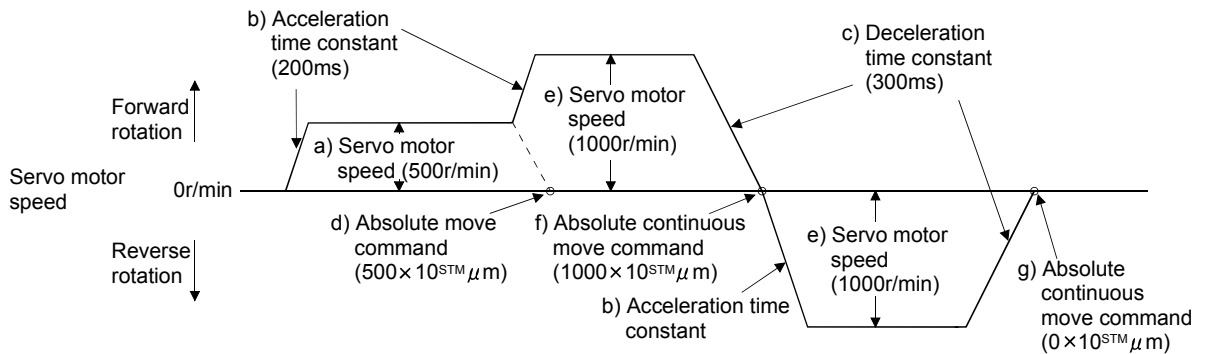

2) Program example 2 (Wrong usage)

In continuous operation, the acceleration or deceleration time constant cannot be changed at each speed change. Hence, the "STA", "STB" or "STD" command is ignored if it is inserted for a speed change.

Program	Description		
SPN(500)	Speed (Motor speed)	500[r/min]	a)
STA(200)	Acceleration time constant	200[ms]	b)
STB(300)	Deceleration time constant	300[ms]	c)
MOV(500)	Absolute move command	$500[\times 10^{STM} \mu m]$	d)
SPN(1000)	Speed (Motor speed)	1000[r/min]	e)
STC(500)	Acceleration/deceleration time constant	500[ms]	f) Ignored.
MOVA(1000)	Absolute continuous move command	$1000[\times 10^{STM} \mu m]$	g)
SPN(1500)	Speed (Motor speed)	1500[r/min]	h)
STC(100)	Acceleration/deceleration time constant	100[ms]	i) Ignored.
MOVA(0)	Absolute continuous move command	$0[\times 10^{STM} \mu m]$	j)
STOP	Program end		

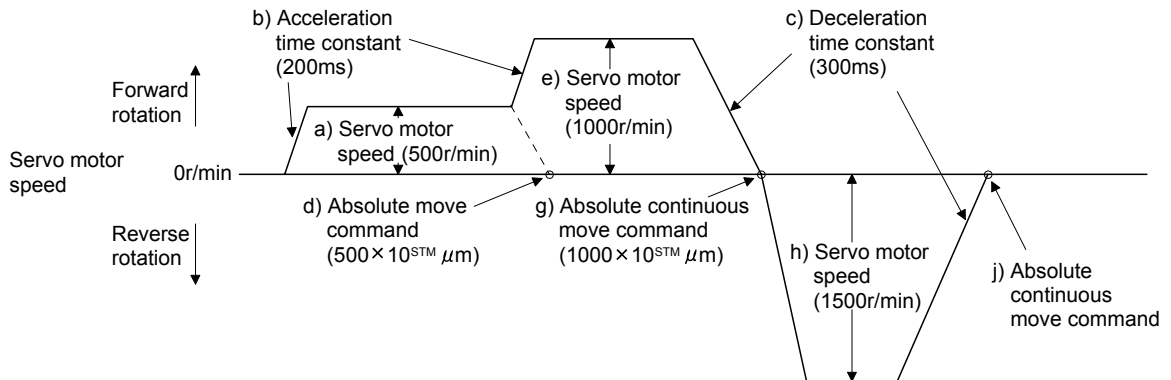

13. POSITIONING MODE

(c) Input/output command (OUTON, OUTOF), trip point command (TRIP, TRIPI)

1) Program example 1

As soon as the program is executed, program output 1 (OUT1) is turned ON. When the program ends, program output 1 (OUT1) turns OFF.

Program	Description	
SPN(1000)	Speed (Motor speed)	1000[r/min]
STA(200)	Acceleration time constant	200[ms]
STB(300)	Deceleration time constant	300[ms]
MOV(500)	Absolute move command	500[×10 ^{STM} μm]
OUTON(1)	Program output 1 (OUT 1) is turned ON.	a)
TIM(100)	Dwell command time	100[ms]
MOV(250)	Absolute move command	250[×10 ^{STM} μm]
TIM(50)	Dwell command time	50[ms]
STOP	Program end	b)

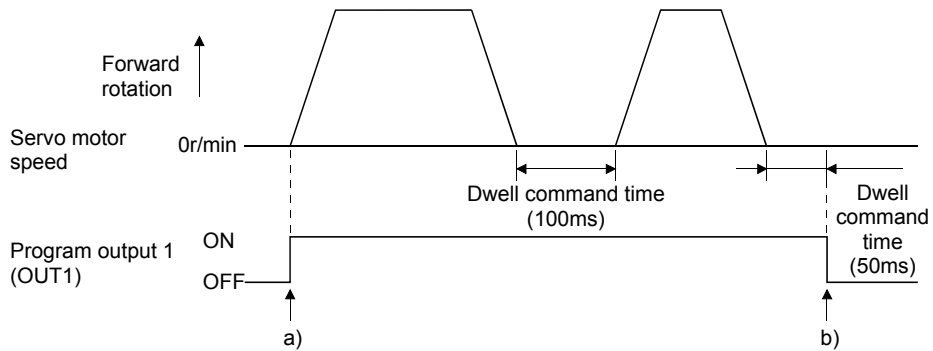

2) Program example 2

Using parameter No. PE14, program output 1 (OUT1) can be turned off automatically.

Parameter No.	Name	Setting	Description
PE14	OUT1 output time selection	200	OUT1 is turned off in 200 [ms]. a)

Program	Description	
SPN(500)	Speed (Motor speed)	500[r/min]
STA(200)	Acceleration time constant	200[ms]
STB(300)	Deceleration time constant	300[ms]
MOV(1000)	Absolute move command	1000[×10 ^{STM} μm]
OUTON(1)	Program output 1 (OUT 1) is turned ON.	
STOP	Program end	

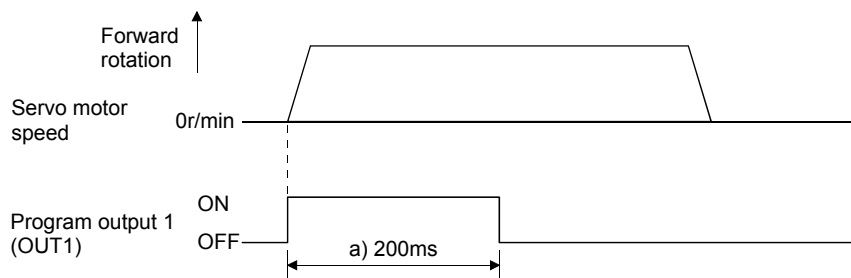

13. POSITIONING MODE

3) Program example 3

When the "TRIP" and "TRIP I" commands are used to set the position addresses where the "OUTON" and "OUTOF" commands will be executed.

Program	Description		
SPN(1000)	Speed (Motor speed)	1000[r/min]	
STA(200)	Acceleration time constant	200[ms]	
STB(300)	Deceleration time constant	300[ms]	
MOV(500)	Absolute move command	$500 \times 10^{\text{STM}} \mu\text{m}$	
TRIP(250)	Absolute trip point	$250 \times 10^{\text{STM}} \mu\text{m}$	a)
OUTON(1)	Program output 1 (OUT 1) is turned ON.		b)
TRIP(400)	Absolute trip point	$400 \times 10^{\text{STM}} \mu\text{m}$	c)
OUTOF(1)	Program output 1 (OUT 1) is turned OFF.		d)
TIM(100)	Dwell command time	100[ms]	
MOVI(500)	Incremental move command	$500 \times 10^{\text{STM}} \mu\text{m}$	
TRIP I(300)	Incremental trip point	$300 \times 10^{\text{STM}} \mu\text{m}$	e)
OUTON(1)	Program output 1 (OUT 1) is turned ON.		f)
STOP	Program end		g)

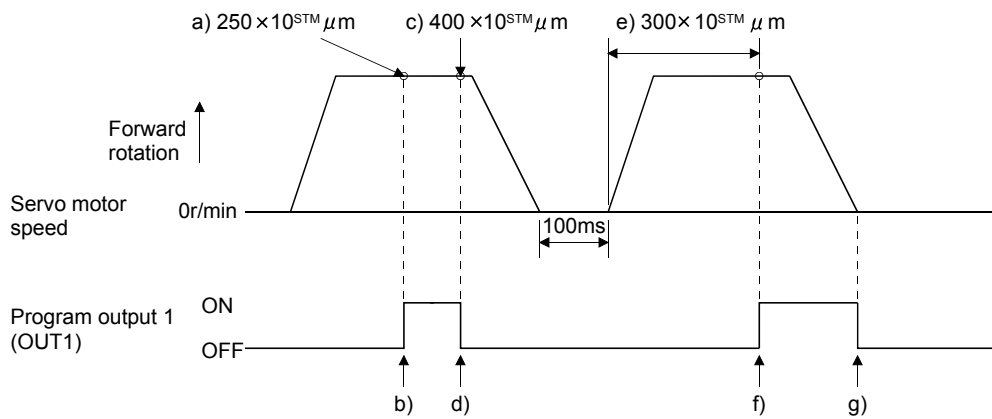

13. POSITIONING MODE

4) Program example 4

POINT
▪ "MOV" cannot be used with "TRIP".

Note that the "TRIP" and "TRIP" commands do not execute the next step unless the axis passes the preset address or travels the preset travel distance.

Program	Description
SPN(500)	Speed (Motor speed) 500[r/min]
STA(200)	Acceleration time constant 200[ms]
STB(300)	Deceleration time constant 300[ms]
MOVI(600)	Incremental move command $600[\times 10^{STM} \mu m]$ a)
TRIP(300)	Incremental trip point $300[\times 10^{STM} \mu m]$ b)
OUTON(1)	Program output 1 (OUT 1) is turned ON. c)
SPN(700)	Speed (Motor speed) 700[r/min]
MOVIA(700)	Incremental continuous move command $700[\times 10^{STM} \mu m]$ d)
TRIP(300)	Incremental trip point $300[\times 10^{STM} \mu m]$ e)
OUTOF(1)	Program output 1 (OUT 1) is turned OFF. f)
STOP	Program end

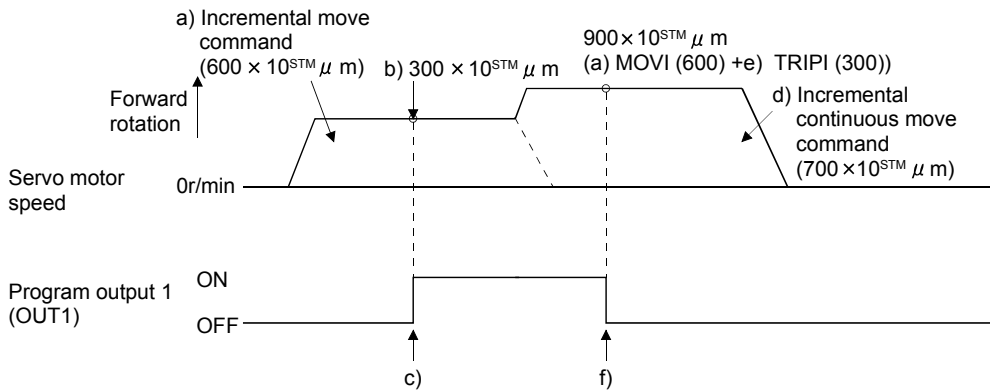

13. POSITIONING MODE

(d) Dwell (TIM)

To the "TIM (setting value)" command, set the time from when the command remaining distance is "0" until the next step is executed.

For reference, the following examples show the operations performed when this command is used with the other commands.

1) Program example 1

Program	Description		
TIM(200)	Dwell command time	200[ms]	a)
SPN(1000)	Speed (Motor speed)	1000[r/min]	
STC(20)	Acceleration/deceleration time constant	20[ms]	
MOV(1000)	Absolute move command	1000[×10 ^{STM} μm]	
STOP	Program end		

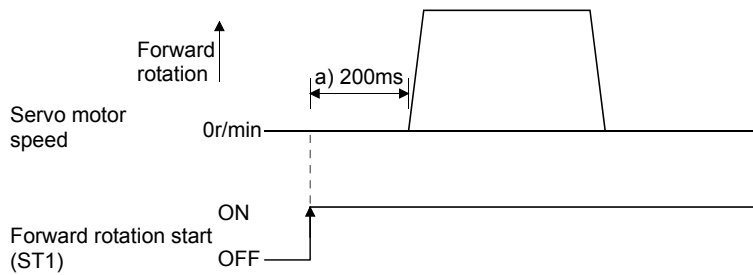

2) Program example 2

Program	Description		
SPN(1000)	Speed (Motor speed)	1000[r/min]	
STC(20)	Acceleration/deceleration time constant	20[ms]	
MOVI(1000)	Incremental move command	1000[×10 ^{STM} μm]	
TIM(200)	Dwell command time	200[ms]	a)
OUTON(1)	Program output 1 (OUT 1) is turned ON.		b)
MOVI(500)	Incremental move command	500[×10 ^{STM} μm]	
STOP	Program end		

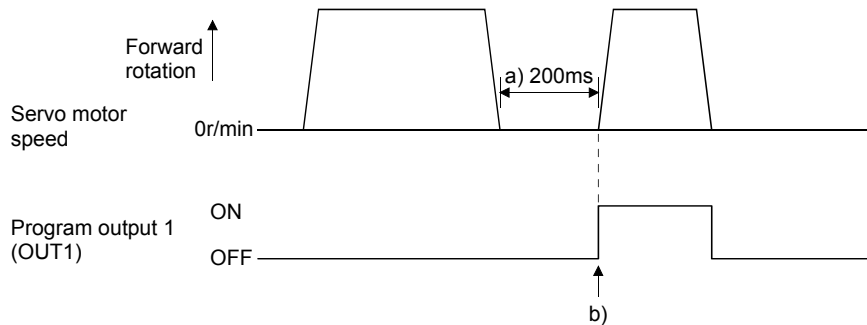

13. POSITIONING MODE

3) Program example 3

Program	Description	
SPN(1000)	Speed (Motor speed)	1000[r/min]
STC(20)	Acceleration/deceleration time constant	20[ms]
MOVI(1000)	Incremental move command	1000[×10 ^{STM} μm]
OUTON(1)	Program output 1 (OUT 1) is turned ON.	a)
TIM(200)	Dwell command time	200[ms]
MOVI(500)	Incremental move command	500[×10 ^{STM} μm]
STOP	Program end	

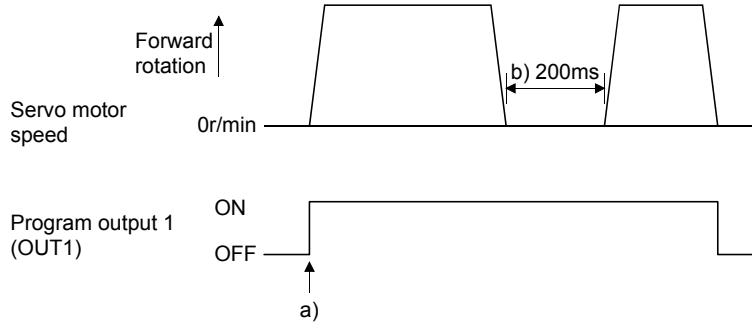

4) Program example 4

Program	Description	
SPN(1000)	Speed (Motor speed)	1000[r/min]
STC(20)	Acceleration/deceleration time constant	20[ms]
MOVI(1000)	Incremental move command	1000[×10 ^{STM} μm]
TIM(200)	Dwell command time	200[ms]
OUTON(1)	Program output 1 (OUT 1) is turned ON.	b)
TIM(300)	Dwell command time	300[ms]
MOVI(500)	Incremental move command	500[×10 ^{STM} μm]
STOP	Program end	

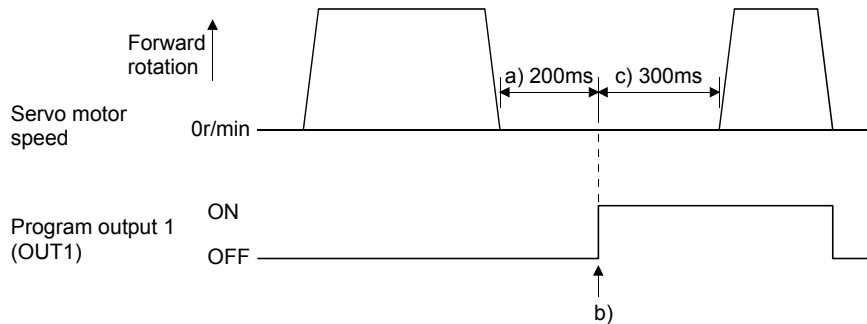

13. POSITIONING MODE

5) Program example 5

Program	Description
SPN(1000)	Speed (Motor speed) 1000[r/min]
STC(20)	Acceleration/deceleration time constant 20[ms]
MOVI(1000)	Incremental move command 1000[×10 ^{STM} μm]
TIM(200)	Dwell command time 200[ms] a)
SYNC(1)	Step is suspended until program input (PI1) turns ON.
MOVI(500)	Incremental move command 500[×10 ^{STM} μm]
STOP	Program end

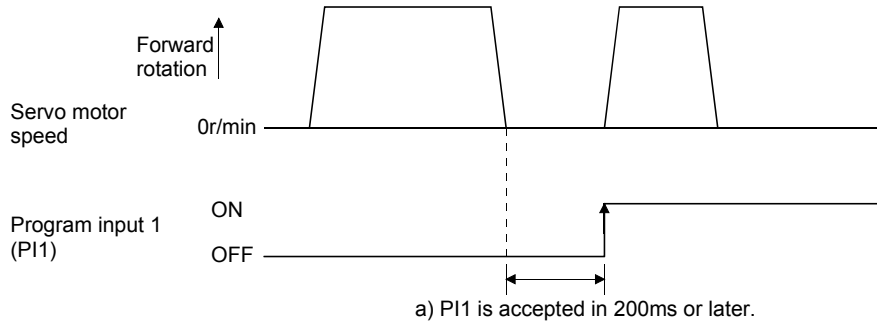

6) Program example 6

Program	Description
SPN(1000)	Speed (Motor speed) 1000[r/min]
STC(20)	Acceleration/deceleration time constant 20[ms]
MOVI(1000)	Incremental move command 1000[×10 ^{STM} μm]
SYNC(1)	Step is suspended until program input (PI1) turns ON.
TIM(200)	Dwell command time 200[ms] a)
MOVI(500)	Incremental move command 500[×10 ^{STM} μm]
STOP	Program end

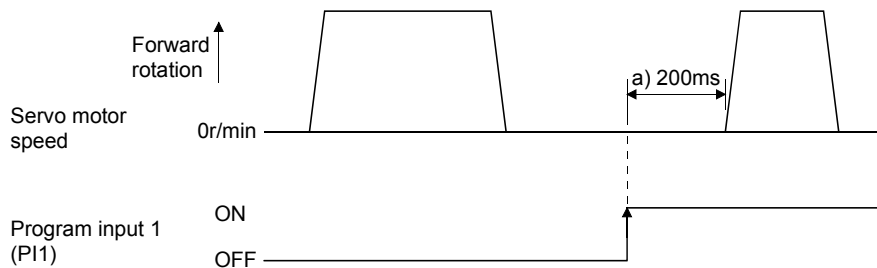

13. POSITIONING MODE

(e) Interrupt positioning command (ITP)

POINT
<ul style="list-style-type: none"> When interrupt positioning command (ITP) is used for positioning, a stop position differs depending on the servo motor speed provided when the "ITP" command is enabled.

When the "ITP" command is used in a program, the axis stops at the position by the set value farther from the position where any of program input 1 (PI1) turned ON.

If the move command set with the "MOV", "MOVI", "MOVA" or "MOVIA" command is less than the setting value of the "ITP (setting value)" command, the program proceeds to the next step without executing the "ITP (setting value)" command.

When using the "ITP" command, always place the "SYNC" command immediately before the "ITP" command.

1) Program example 1

Program	Description
SPN(500)	Speed (Motor speed) 500[r/min]
STA(200)	Acceleration time constant 200[ms]
STB(300)	Deceleration time constant 300[ms]
MOV(600)	Absolute move command $600[\times 10^{STM} \mu m]$
SPN(100)	Speed (Motor speed) 100[r/min]
MOVA(600)	Continuous move command $600[\times 10^{STM} \mu m]$
SYNC(1)	Step is suspended until program input (PI1) turns ON. a)
ITP(200)	Interrupt positioning command $200[\times 10^{STM} \mu m]$ b)
STOP	Program end

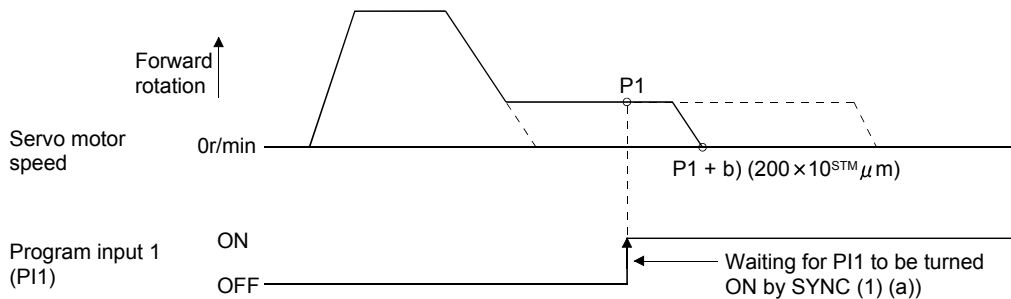

13. POSITIONING MODE

2) Program example 2

If the travel distance of the "ITP" command is less than the travel distance necessary for deceleration, the actual deceleration time constant becomes less than the set value of the "STB" command.

Program	Description	
SPN(500)	Speed (Motor speed)	500[r/min]
STA(200)	Acceleration time constant	200[ms]
STB(300)	Deceleration time constant	300[ms]
MOV(1000)	Absolute move command	1000[$\times 10^{\text{STM}}$ μm]
SYNC(1)	Step is suspended until program input (PI1) turns ON.	a)
ITP(50)	Interrupt positioning command	50[$\times 10^{\text{STM}}$ μm]
STOP	Program end	

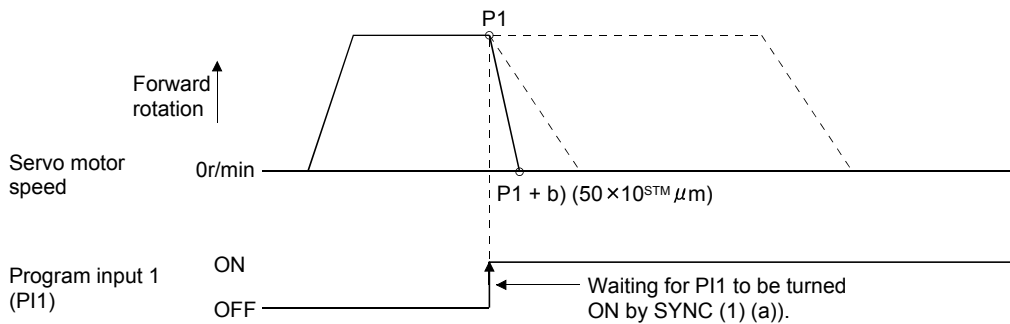

(f) External pulse counter (COUNT)

When the number of input pulses of the manual pulse generator becomes greater than the value set with the "COUNT" command, the next step is started. Set "0" to erase the accumulated input pulses.

Program	Description	
COUNT(500)	The next step is held until the number of input pulses of the manual pulse generator reaches 500 [pulses].	a)
SPN(500)	Speed (Motor speed)	500[r/min]
STA(200)	Acceleration time constant	200[ms]
STB(300)	Deceleration time constant	300[ms]
MOV(1000)	Absolute move command	1000[$\times 10^{\text{STM}}$ μm]
TRIP(500)	Trip point	500[$\times 10^{\text{STM}}$ μm]
COUNT(0)	Cumulative input pulses are cleared.	c)
STOP	Program end	

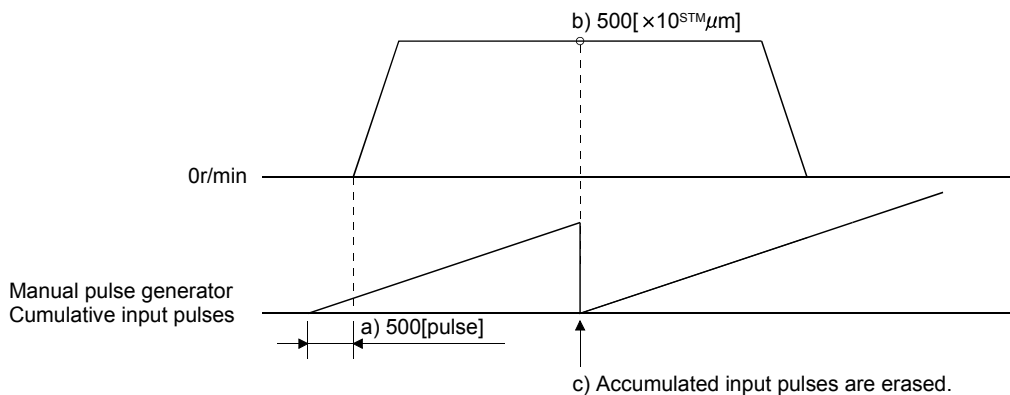

13. POSITIONING MODE

(g) Step repeat command (FOR ... NEXT)

POINT
▪ "FOR ... NEXT" cannot be placed within "FOR ... NEXT".

The steps located between the "FOR (setting value)" command and "NEXT" command is repeated by the preset number of times.

Program	Description
SPN(1000)	Speed (Motor speed) 1000[r/min]
STC(20)	Acceleration/deceleration time constant 20[ms]
MOV(1000)	Absolute move command 1000[×10 ^{STM} μm]
TIM(100)	Dwell command time 100[ms]
FOR(3)	Step repeat command start 3 [times] a)
MOVI(100)	Incremental move command 100[×10 ^{STM} μm] b)
TIM(100)	Dwell command time 100[ms]
NEXT	Step repeat command end c)
FOR(2)	Step repeat command start 2 [times] d)
MOVI(200)	Incremental move command 200[×10 ^{STM} μm] e)
TIM(100)	Dwell command time 100[ms]
NEXT	Step repeat command end f)
STOP	Program end

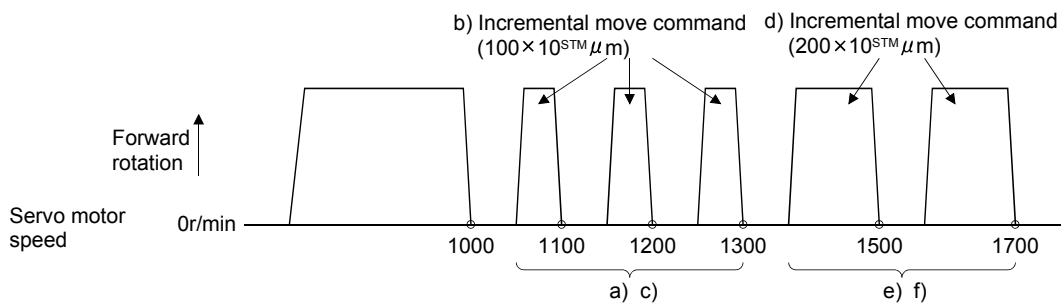

13. POSITIONING MODE

(h) Program repeat command (TIMES)

By setting the number of times to the "TIMES (setting value)" command placed at the beginning of a program, the program can be executed repeatedly. When the program is to be executed once, the "TIMES (setting value)" command is not necessary. Set "0" to select endless repetition.

Program	Description
TIMES(2)	Program repeat command 2 [times] a)
SPN(1000)	Speed (Motor speed) 1000[r/min]
STC(20)	Acceleration/deceleration time constant 20[ms]
MOVI(1000)	Incremental move command $1000 \times 10^{\text{STM}} \mu\text{m}$ b)
TIM(100)	Dwell command time 100[ms]
STOP	Program end

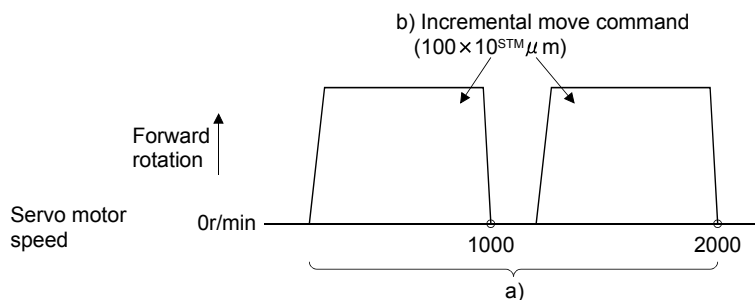

13. POSITIONING MODE

13.4.3 Basic setting of signals and parameters

Create programs in advance using MR Configurator. (Refer to sections 13.4.2, and 13.9.)

(1) Parameter

(a) Command mode selection (parameter No. PE01)

Make sure that the absolute value command system has been selected as shown below.

Parameter No. PE01

			0
--	--	--	---

└ Absolute value command system (initial value)

(b) ST1 coordinate system selection (parameter No. PA14)

Select the servo motor rotation direction at the time when the forward rotation start (ST1) turns ON.

Parameter No. PA14 setting	Servo motor rotation direction when forward rotation start (ST1) is turned on
<input type="checkbox"/> <input type="checkbox"/> <input type="checkbox"/> 0 (initial value)	CCW rotation with + position data CW rotation with - position data
<input type="checkbox"/> <input type="checkbox"/> <input type="checkbox"/> 1	CW rotation with + position data CCW rotation with - position data

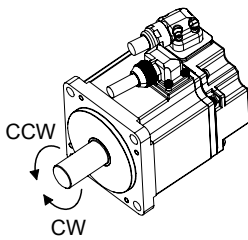

(c) Feed length multiplication (parameter No. PE02)

Set the feed length multiplication (STM) of position data.

Parameter No. PE02 setting	Position data input range [mm]
<input type="checkbox"/> <input type="checkbox"/> <input type="checkbox"/> 0 (initial value)	-999.999 to +999.999
<input type="checkbox"/> <input type="checkbox"/> <input type="checkbox"/> 1	-9999.99 to +9999.99
<input type="checkbox"/> <input type="checkbox"/> <input type="checkbox"/> 2	-99999.9 to +99999.9
<input type="checkbox"/> <input type="checkbox"/> <input type="checkbox"/> 3	-999999 to +999999

(2) Signals

Choosing the program using DI0 to DI2 and turning ON ST1 performs positioning operation according to the set program. At this time, reverse rotation start (ST2) is invalid.

Item	Setting method	Description
Selection of program operation mode	Automatic/manual selection (MD0)	Turn MD0 ON.
Program selection	Point table No./Program No. selection 1 (DI0) Point table No./Program No. selection 2 (DI1) Point table No./Program No. selection 3 (DI2)	Refer to section 13.2.3.(1).
Start	Forward rotation start (ST1)	Turn ON ST1 to start the program operation

13. POSITIONING MODE

13.4.4 Program operation timing chart

(1) Operation conditions

The timing chart shown below assumes that the following program is executed in the absolute value command system where a home position return is completed.

Program No. 1	Description	
SPN(1000)	Speed (Motor speed)	1000[r/min]
STC(100)	Acceleration/deceleration time constant	100[ms]
MOV(5000)	Absolute move command	5000[×10 ^{STM} μm] Move command 1
SYNC(1)	Step is suspended until program input (PI1) turns ON.	
STC(50)	Acceleration/deceleration time constant	50[ms]
MOV(7500)	Absolute move command	7500[×10 ^{STM} μm] Move command 2
STOP	Program end	

Program No. 2	Description	
SPN(1000)	Speed (Motor speed)	1000[r/min]
STC(100)	Acceleration/deceleration time constant	100[ms]
MOV(2500)	Absolute move command	2500[×10 ^{STM} μm] Move command 3
SYNC(1)	Step is suspended until program input (PI1) turns ON.	
STC(50)	Acceleration/deceleration time constant	50[ms]
MOV(5000)	Absolute move command	5000[×10 ^{STM} μm] Move command 4
STOP	Program end	

(2) Timing chart

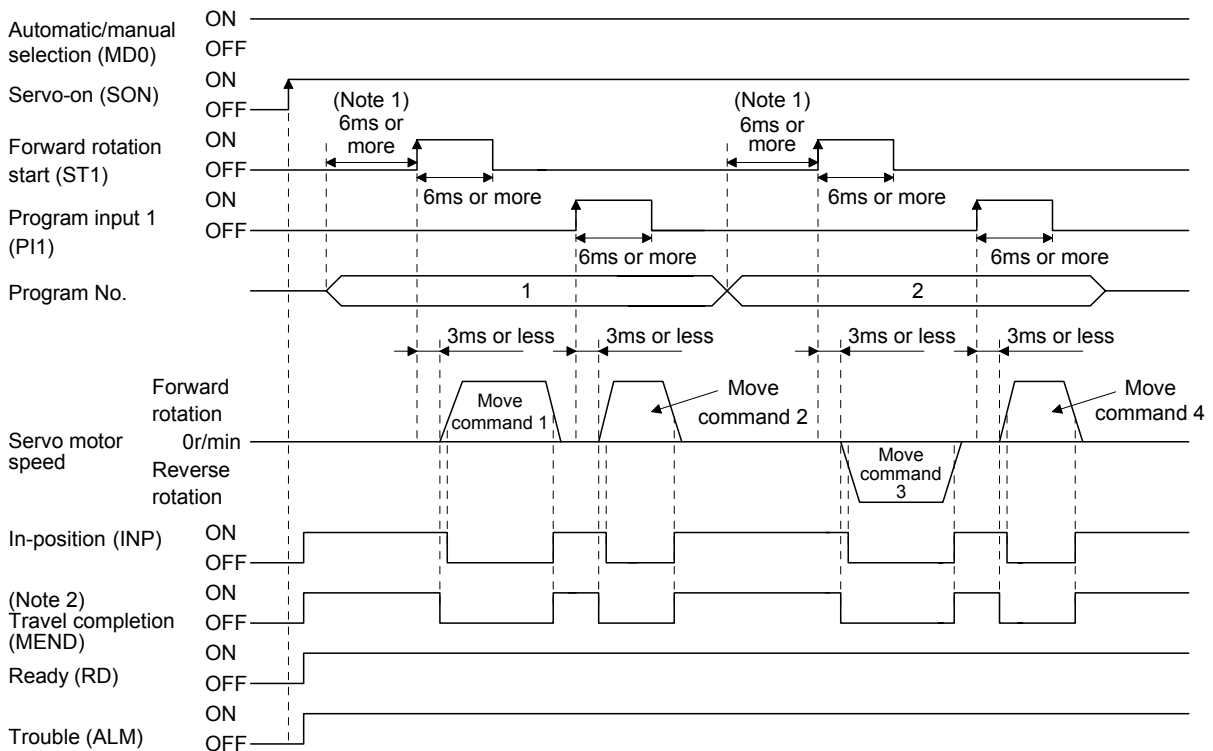

Note 1. External input signal detection delays by the input filter setting time of parameter No. PD19. Additionally, make up a sequence that changes the program selection ahead of time by considering delays in output signal sequence from the controller and variations of a signal change due to hardware.

2. If the over load tough drive function is enabled by setting parameter No. PA04 to "□□1", INP turn-on delays during the overload tough drive. MEND turn-on also delays together with INP.

13. POSITIONING MODE

13.5 Manual operation mode

For machine adjustment, home position matching, etc., JOG operation or a manual pulse generator may be used to make a motion to any position.

13.5.1 JOG operation

(1) Setting

Set the input device and parameters as follows according to the purpose of use. In this case, the point table No./program No. selection 1 to 3 (DI0 to DI2) are invalid.

Item	Device/Parameter used	Description
Manual operation mode selection	Automatic/manual selection (MD0)	Turn MD0 OFF.
Servo motor rotation direction	Parameter No. PA14	Refer to (2) in this section.
JOG speed	Parameter No. PE13	Set the speed of the servo motor.
Acceleration/deceleration time constant	Parameter No. PE07	Set the acceleration/deceleration time constants.
S-pattern acceleration/deceleration time constant	Parameter No. PC03	Set the S-pattern acceleration/deceleration time constant.

(2) Servo motor rotation direction

Parameter No. PA14 setting	Servo motor rotation direction	
	Forward rotation start (ST1) ON	Reverse rotation start (ST2) ON
0	CCW rotation	CW rotation
1	CW rotation	CCW rotation

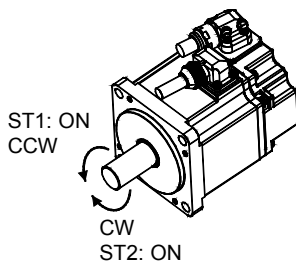

Parameter No. PA14: 0

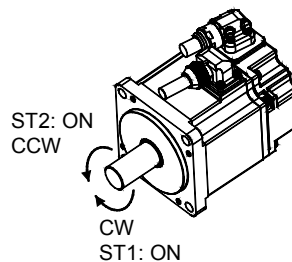

Parameter No. PA14: 1

(3) Operation

By turning ST1 ON, operation is performed under the conditions of the JOG speed set in the parameter and the acceleration and deceleration time constants in set parameter No. PE07. For the rotation direction, refer to (2) in this section. By turning ST2 ON, the servo motor rotates in the reverse direction to forward rotation start (ST1).

13. POSITIONING MODE

(4) Timing chart

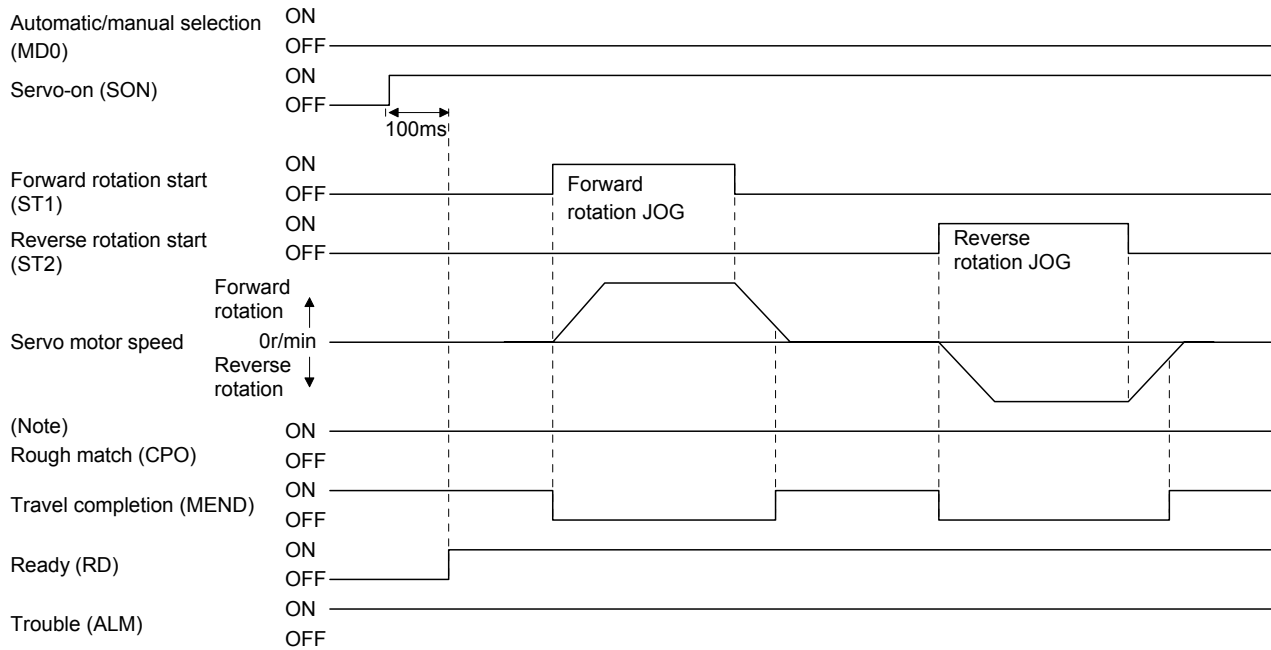

Note. For the point table method. For the program method, it is always OFF.

13.5.2 Manual pulse generator operation

POINT
<ul style="list-style-type: none"> For the positioning mode, PP or NP is not assigned in the initial status. When using the manual pulse generator, assign PP to CN1-23 pin and NP to CN1-25 pin by parameter No. PD02. (Refer to sections 4.4.2 and 11.14.) When the manual pulse generator is used during JOG operation, pulses of the manual pulse generator are added.

(1) Setting

Set the input device and parameters as follows according to the purpose of use. In this case, the point table No./program No. selection 1 to 3 (DI0 to DI2) are invalid.

Item	Device/Parameter used	Description
Manual operation mode selection	Automatic/manual selection (MD0)	Turn MD0 OFF.
Manual pulse generator multiplication	Parameter No. PE02	Set the multiplication ratio for generated pulses of the manual pulse generator. For more information, refer to (3) in this section.
Servo motor rotation direction	Parameter No. PA14	Refer to (2) in this section.

13. POSITIONING MODE

(2) Servo motor rotation direction

Parameter No. PA14 setting	Servo motor rotation direction	
	Manual pulse generator: forward rotation	Manual pulse generator: reverse rotation
0	CCW rotation	CW rotation
1	CW rotation	CCW rotation

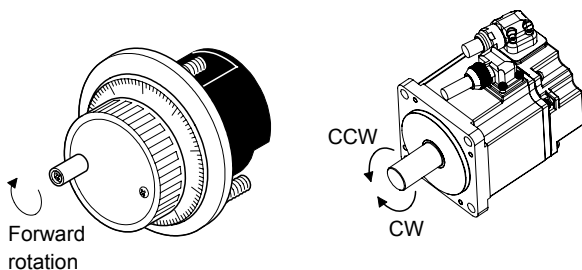

(3) Manual pulse generator multiplication

Use parameter No. PA05 to set the multiplication ratio of the servo motor rotation to the manual pulse generator rotation.

Parameter No. PA05 setting	Multiplication ratio of servo motor rotation to manual pulse generator rotation	Travel distance
<input type="checkbox"/> <input type="checkbox"/> 0 <input type="checkbox"/>	1 time	1[μ m]
<input type="checkbox"/> <input type="checkbox"/> 1 <input type="checkbox"/>	10 times	10[μ m]
<input type="checkbox"/> <input type="checkbox"/> 2 <input type="checkbox"/>	100 times	100[μ m]

(4) Operation

Turn the manual pulse generator to rotate the servo motor. For the rotation direction of servo motor, refer to (2) in this section.

13. POSITIONING MODE

13.6 Home position return mode

13.6.1 Outline of home position return

Home position return is performed to match the command coordinates with the machine coordinates. In the incremental system, home position return is required every time input power is switched on.

This servo amplifier has the home position return methods given in this section. Choose the most appropriate method for your machine structure and application.

This servo amplifier has the home position return automatic return function which executes home position return by making an automatic return to a proper position if the machine has stopped beyond or on the proximity dog. Manual motion by JOG operation or the like is not required.

(1) Home position return types

Choose the optimum home position return according to the machine type, etc.

Type	Home position return method	Features
Dog type	With deceleration started at the front end of a proximity dog, the position where the first Z-phase signal is given past the rear end of the dog or a motion has been made over the home position shift distance starting from the Z-phase signal is defined as a home position. (Note)	<ul style="list-style-type: none"> • General home position return method using a proximity dog. • Repeatability of home position return is excellent. • The machine is less burdened. • Used when the width of the proximity dog can be set greater than the deceleration distance of the servo motor.
Count type	With deceleration started at the front end of a proximity dog, the position where the first Z-phase signal is given after advancement over the preset moving distance after the proximity dog or a motion has been made over the home position shift distance starting from the Z-phase signal is defined as a home position.	<ul style="list-style-type: none"> • Home position return method using a proximity dog. • Used when it is desired to minimize the length of the proximity dog.
Data set type	An arbitrary position is defined as a home position.	<ul style="list-style-type: none"> • No proximity dog required.
Stopper type	The position where the machine stops when its part is pressed against a machine stopper is defined as a home position.	<ul style="list-style-type: none"> • Since the machine part collides with the machine be fully lowered. • The machine and stopper strength must be increased.
Home position ignorance (Servo-on position as home position)	The position where servo is switched on is defined as a home position.	
Dog type rear end reference	The position where the axis, which had started decelerating at the front end of a proximity dog, has moved the after-proximity dog moving distance and home position shift distance after it passed the rear end is defined as a home position.	<ul style="list-style-type: none"> • The Z-phase signal is not needed.
Count type front end reference	The position where the axis, which had started decelerating at the front end of a proximity dog, has moved the after-proximity dog moving distance and home position shift distance is defined as a home position.	<ul style="list-style-type: none"> • The Z-phase signal is not needed.
Dog cradle type	The position where the first Z-phase signal is issued after detection of the proximity dog front end is defined as a home position.	

Note. The Z-phase signal is a signal recognized in the servo amplifier once per servo motor revolution. It cannot be used as an output signal.

13. POSITIONING MODE

(2) Home position return parameter

When performing home position return, set parameter No. PE03 (home position return type) as follows.

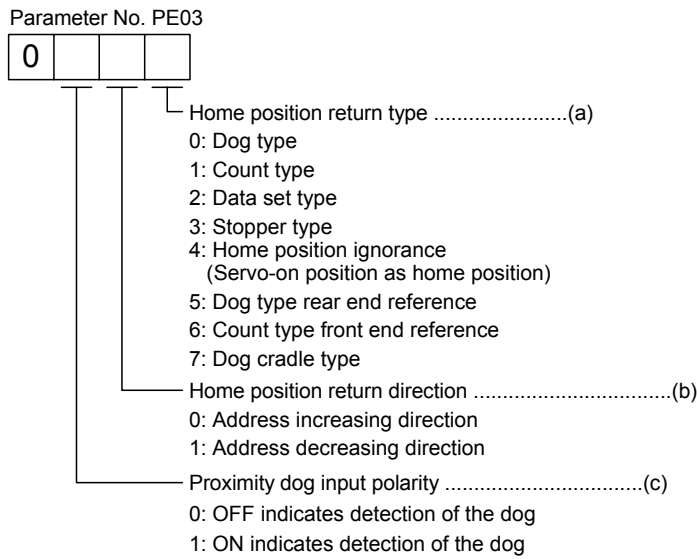

- (a) Choose the home position return type.
- (b) Choose the starting direction of home position return. Set "0" to start home position return in the direction in which the address is incremented from the current position, or "1" to start home position return in the direction in which the address is decremented.
- (c) Choose the polarity at which the proximity dog is detected. Set "0" to detect the dog when the proximity dog device (DOG) is OFF, or "1" to detect the dog when the device is ON.

(3) Instructions

- (a) Before starting home position return, always make sure that the limit switch operates.
- (b) Confirm the home position return direction. Incorrect setting will cause the machine to run reversely.
- (c) Confirm the proximity dog input polarity. Not doing so may cause unexpected operation.

13.6.2 Selection of home position return mode

Set the input device as shown in the following table to select the home position return mode.

Input device	Device setting	
	Point table method	Program method
Automatic/manual selection (MD0)	OFF	OFF
Point table No./Program No. selection 1 (DI0)	All OFF (The home position return mode is selected.)	Select a program that has the home position return "ZRT" command.
Point table No./Program No. selection 2 (DI1)		
Point table No./Program No. selection 3 (DI2)		

The explanations in the following sections apply when the home position return mode is selected by MD0, MI0, DI1, and DI2.

13. POSITIONING MODE

13.6.3 Dog type home position return

This is a home position return method using the proximity dog. With deceleration started at the front end of the proximity dog, the position where the first Z-phase signal is given past the rear end of the dog or a motion has been made over the home position shift distance starting from the Z-phase signal is defined as a home position.

(1) Devices and parameters

Set the input devices and parameters as follows.

Item	Device/Parameter used	Description
Home position return mode selection	Automatic/manual selection (MD0)	Turn MD0 ON.
	Point table No./Program No. selection 1 to 3 (DI0 to DI2)	Point table method: Select the home position return mode by turning OFF DI0, DI1 and DI2. Program method: Select a program that has the home position return "ZRT" command.
Dog type home position return	Parameter No. PE03	<input type="checkbox"/> <input type="checkbox"/> <input type="checkbox"/> 0: Dog type home position return is selected.
Home position return direction	Parameter No. PE03	Refer to section 13.6.1 (2) and select the home position return direction.
Dog input polarity	Parameter No. PE03	Refer to section 13.6.1 (2) and select the proximity dog input polarity.
Home position return speed	Parameter No. PE04	Set the speed till the dog is detected.
Creep speed	Parameter No. PE05	Set the speed after the dog is detected.
Home position shift distance	Parameter No. PE06	Set when shifting the home position starting at the first Z-phase signal after passage of proximity dog rear end.
Home position return acceleration /deceleration time constants	Parameter No. PE07	Set the acceleration/deceleration time constants during a home position return.
Home position return position data	Parameter No. PE08	Set the current position at home position return completion.

(2) Length of proximity dog

To ensure that the Z-phase signal of the servo motor is generated during detection of the proximity dog (DOG), the proximity dog should have the length which satisfies formulas (13.1) and (13.2).

$$L_1 \geq \frac{V}{60} \cdot \frac{td}{2} \dots \dots \dots (13.1)$$

L₁ : Proximity dog length [mm]
V : Home position return speed [mm/min]
Td : Deceleration time [s]

$$L_2 \geq 2 \cdot \Delta S \cdot \dots \dots \dots (13.2)$$

L₂ : Proximity dog length [mm]
ΔS: Travel distance per servo motor revolution [mm]

13. POSITIONING MODE

(3) Timing chart

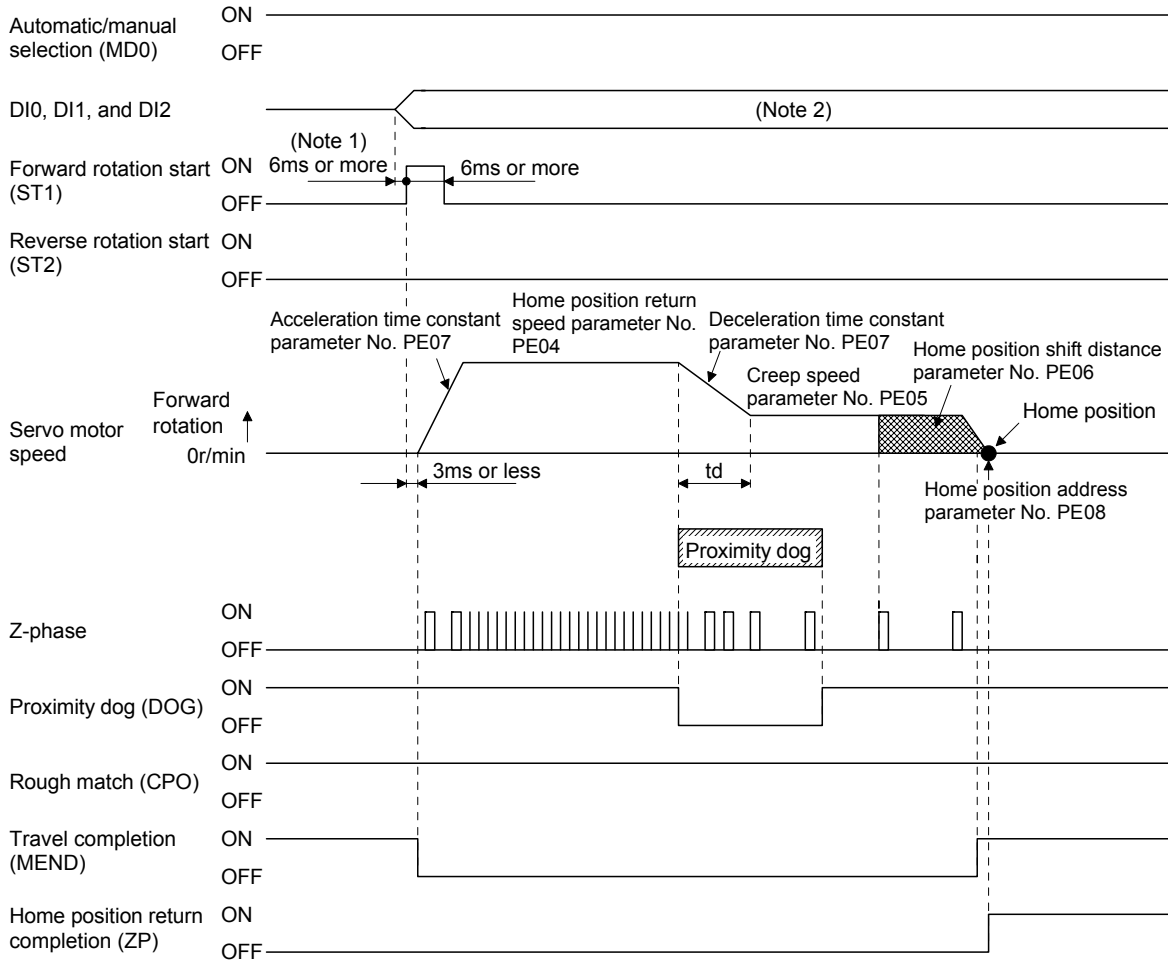

Note 1. External input signal detection delays by the input filter setting time of parameter No. PD19. Additionally, make up a sequence that changes DI0, DI1 and DI2 ahead of time by considering delays in output signal sequence from the controller and variations of a signal change due to hardware.

- Point table method: Select the home position return mode by turning OFF DI0, DI1 and DI2.
- Program method: Select a program that has the home position return "ZRT" command.

The set value in parameter No. PE08 (home position return position data) is applied as position address at the time of the home position return being completed.

13. POSITIONING MODE

13.6.4 Count type home position return

In count type home position return, a motion is made over the distance set in parameter No. PE09 (moving distance after proximity dog) after detection of the proximity dog front end. The position where the first Z-phase signal is given after that is defined as a home position. Hence, if the proximity dog (DOG) is 10ms or longer, there is no restriction on the dog length. This home position return method is used when the required proximity dog length cannot be reserved to use dog type home position return or when the proximity dog (DOG) is entered electrically from a controller or the like.

(1) Devices and parameters

Set the input devices and parameters as follows.

Item	Device/Parameter used	Description
Manual home position return mode selection	Automatic/manual selection (MD0)	Turn MD0 ON.
	Point table No./Program No. selection 1 to 3 (DI0 to DI2)	Point table method: Select the home position return mode by turning OFF DI0, DI1 and DI2. Program method: Select a program that has the home position return "ZRT" command.
Count type home position return	Parameter No. PE03	<input type="checkbox"/> <input type="checkbox"/> <input type="checkbox"/> 1: Count type home position return is selected.
Home position return direction	Parameter No. PE03	Refer to section 13.6.1 (2) and select the home position return direction.
Dog input polarity	Parameter No. PE03	Refer to section 13.6.1 (2) and select the dog input polarity.
Home position return speed	Parameter No. PE04	Set the speed till the dog is detected.
Creep speed	Parameter No. PE05	Set the speed after the dog is detected.
Home position shift distance	Parameter No. PE06	Set when shifting the home position, starting at the first Z-phase signal given after passage of the proximity dog front end and movement over the travel distance.
Travel distance after proximity dog	Parameter No. PE09	Set the travel distance after passage of proximity dog front end.
Home position return acceleration/deceleration time constants	Parameter No. PE07	Set the acceleration/deceleration time constants during a home position return.
Home position return position data	Parameter No. PE08	Set the current position at home position return completion.

13. POSITIONING MODE

(2) Timing chart

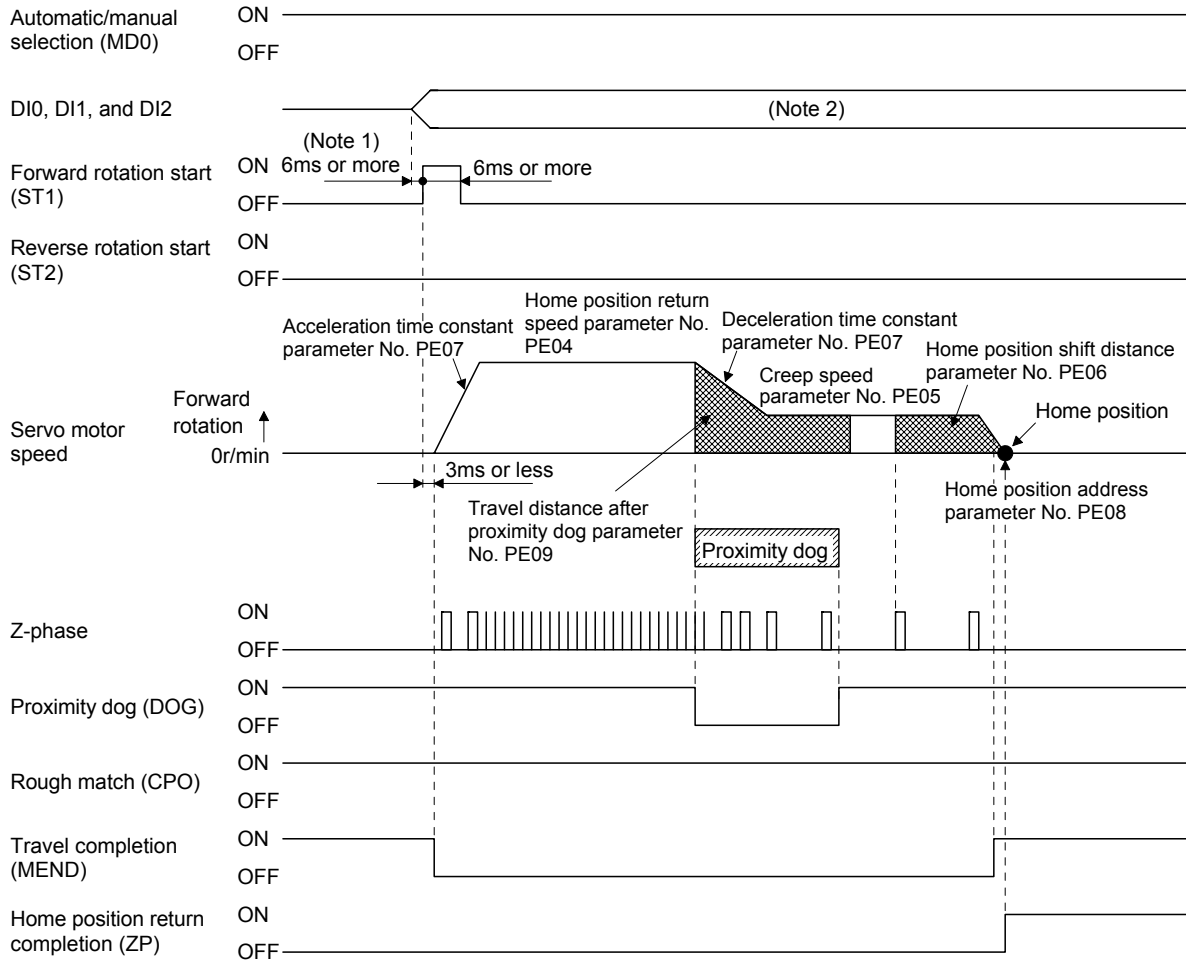

- Note 1. External input signal detection delays by the input filter setting time of parameter No. PD19. Additionally, make up a sequence that changes DI0, DI1 and DI2 ahead of time by considering delays in output signal sequence from the controller and variations of a signal change due to hardware.
2. Point table method: Select the home position return mode by turning OFF DI0, DI1 and DI2.
 Program method: Select a program that has the home position return "ZRT" command.

The set value in parameter No. PE08 (home position return position data) is applied as position address at the time of the home position return being completed.

13. POSITIONING MODE

13.6.5 Data set type home position return

Data set type home position return is used when it is desired to determine any position as a home position. JOG operation can be used for movement.

(1) Devices and parameters

Set the input devices and parameters as follows.

Item	Device/Parameter used	Description
Manual home position return mode selection	Automatic/manual selection (MD0)	Turn MD0 ON.
	Point table No./Program No. selection 1 to 3 (DI0 to DI2)	Point table method: Select the home position return mode by turning OFF DI0, DI1 and DI2. Program method: Select a program that has the home position return "ZRT" command.
Data set type home position return	Parameter No. PE03	<input type="checkbox"/> <input type="checkbox"/> <input type="checkbox"/> 2: Data set type home position return is selected.
Home position return position data	Parameter No. PE08	Set the current position at home position return completion.

(2) Timing chart

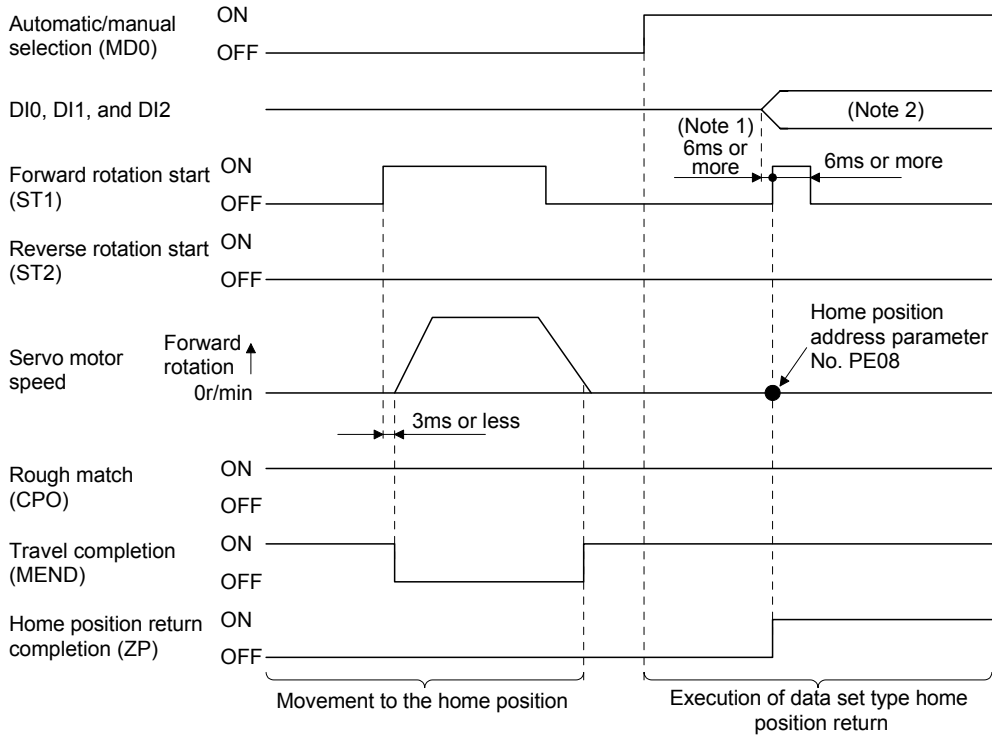

Note 1. External input signal detection delays by the input filter setting time of parameter No. PD19. Additionally, make up a sequence that changes DI0, DI1 and DI2 ahead of time by considering delays in output signal sequence from the controller and variations of a signal change due to hardware.

- Point table method: Select the home position return mode by turning OFF DI0, DI1 and DI2.
Program method: Select a program that has the home position return "ZRT" command.

The set value in parameter No. PE08 (home position return position data) is applied as position address at the time of the home position return being completed.

13. POSITIONING MODE

13.6.6 Stopper type home position return

In stopper type home position return, a machine part is pressed against a stopper or the like by JOG operation to make a home position return and that position is defined as a home position.

(1) Devices and parameters

Set the input devices and parameters as follows.

Item	Device/Parameter used	Description
Manual home position return mode selection	Automatic/manual selection (MD0)	Turn MD0 ON.
	Point table No./Program No. selection 1 to 3 (DI0 to DI2)	Point table method: Select the home position return mode by turning OFF DI0, DI1 and DI2. Program method: Select a program that has the home position return "ZRT" command.
Stopper type home position return	Parameter No. PE03	<input type="checkbox"/> <input type="checkbox"/> <input type="checkbox"/> 3: Stopper type home position return is selected.
Home position return direction	Parameter No. PE03	Refer to section 13.6.1 (2) and select the home position return direction.
Home position return speed	Parameter No. PE04	Set the speed till contact with the stopper.
Stopper time	Parameter No. PE10	Time from when the part makes contact with the stopper to when home position return data is obtained to output home position return completion (ZP).
Stopper type home position return torque limit value	Parameter No. PE11	Set the servo motor torque limit value for execution of stopper type home position return.
Home position return acceleration time constant	Parameter No. PE07	Set the acceleration time constant during a home position return.
Home position return position data	Parameter No. PE08	Set the current position at home position return completion.

13. POSITIONING MODE

(2) Timing chart

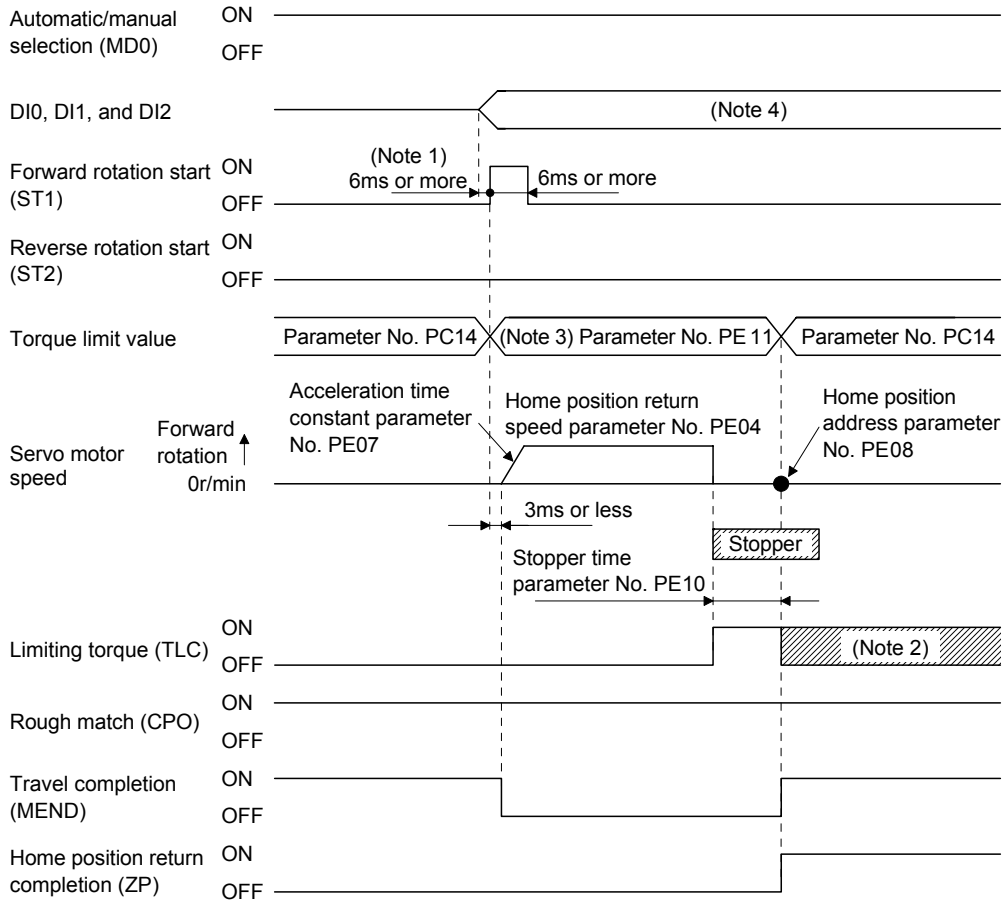

Note 1. External input signal detection delays by the input filter setting time of parameter No. PD19. Additionally, make up a sequence that changes DI0, DI1 and DI2 ahead of time by considering delays in output signal sequence from the controller and variations of a signal change due to hardware.

2. TLC turns ON when the torque reaches the value set in forward torque limit (parameter No. PA11), reverse torque limit (parameter No. PA12) or internal torque limit (parameter No. PC14).

3. The torque limit that is enabled at this point is as follows.

(Note)	Input device	Limit value status	Validated torque limit values
	TL1		
0			Parameter No. PE11
1		Parameter No. PC14 > Parameter No. PE11	Parameter No. PE11
		Parameter No. PC14 < Parameter No. PE11	Parameter No. PC14

Note. 0: off

1: on

4. Point table method: Select the home position return mode by turning OFF DI0, DI1 and DI2.
 Program method: Select the program that has the home position return "ZRT" command.

The set value in parameter No. PE08 (home position return position data) is applied as position address at the time of the home position return being completed.

13. POSITIONING MODE

13.6.7 Home position ignorance (Servo-on position as home position)

The position where servo is switched on is defined as a home position.

(1) Devices and parameters

Set the input devices and parameters as follows.

Item	Device/Parameter used	Description
Manual home position return mode selection	Automatic/manual selection (MD0)	Turn MD0 ON.
	Point table No./Program No. selection 1 to 3 (DI0 to DI2)	Point table method: Select the home position return mode by turning OFF DI0, DI1 and DI2. Program method: Select a program that has the home position return "ZRT" command.
Home position ignorance	Parameter No. PE03	<input type="checkbox"/> <input type="checkbox"/> <input type="checkbox"/> 4: Home position ignorance is selected.
Home position return position data	Parameter No. PE08	Set the current position at home position return completion.

(2) Timing chart

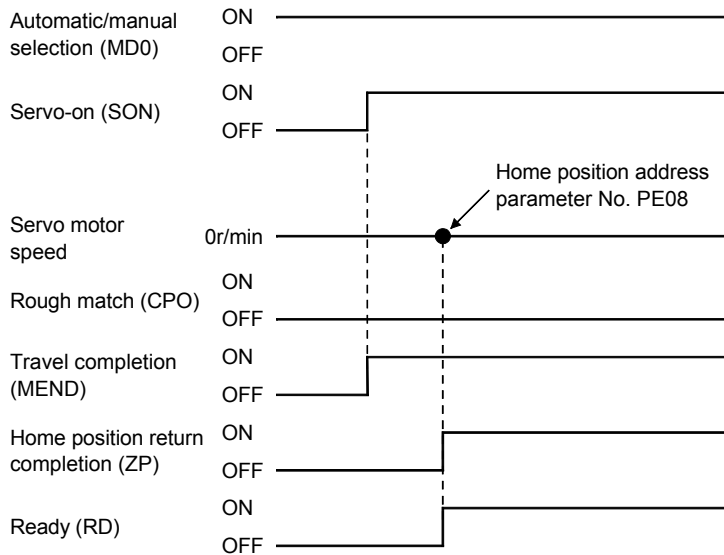

The set value in parameter No. PE08 (home position return position data) is applied as position address at the time of the home position return being completed.

13. POSITIONING MODE

13.6.8 Dog type rear end reference home position return

POINT
<ul style="list-style-type: none"> This home position return method depends on the timing of reading proximity dog (DOG) that has detected the rear end of a proximity dog. Hence, if a home position return is made at the creep speed of 100r/min, an error of ± 400 pulses will occur in the home position. The error of the home position is larger as the creep speed is higher.

The position where the axis, which had started decelerating at the front end of a proximity dog, has moved the after-proximity dog moving distance and home position shift distance after it passed the rear end is defined as a home position. A home position return that does not depend on the Z-phase signal can be made.

(1) Devices and parameters

Set the input devices and parameters as follows.

Item	Device/Parameter used	Description
Manual home position return mode selection	Automatic/manual selection (MD0)	Turn MD0 ON.
	Point table No./Program No. selection 1 to 3 (DI0 to DI2)	Point table method: Select the home position return mode by turning OFF DI0, DI1 and DI2. Program method: Select a program that has the home position return "ZRT" command.
Dog type rear end reference home position return	Parameter No. PE03	<input type="checkbox"/> <input type="checkbox"/> <input type="checkbox"/> 5: Select the dog type rear end reference.
Home position return direction	Parameter No. PE03	Refer to section 13.6.1 (2) and select the home position return direction.
Dog input polarity	Parameter No. PE03	Refer to section 13.6.1 (2) and select the dog input polarity.
Home position return speed	Parameter No. PE04	Set the speed till the dog is detected.
Creep speed	Parameter No. PE05	Set the speed after the dog is detected.
Home position shift distance	Parameter No. PE06	Set when the home position is moved from where the axis has passed the proximity dog front end.
Travel distance after proximity dog	Parameter No. PE09	
Home position return acceleration/deceleration time constants	Parameter No. PE07	Set the acceleration/deceleration time constants during a home position return.
Home position return position data	Parameter No. PE08	Set the current position at home position return completion.

13. POSITIONING MODE

(2) Timing chart

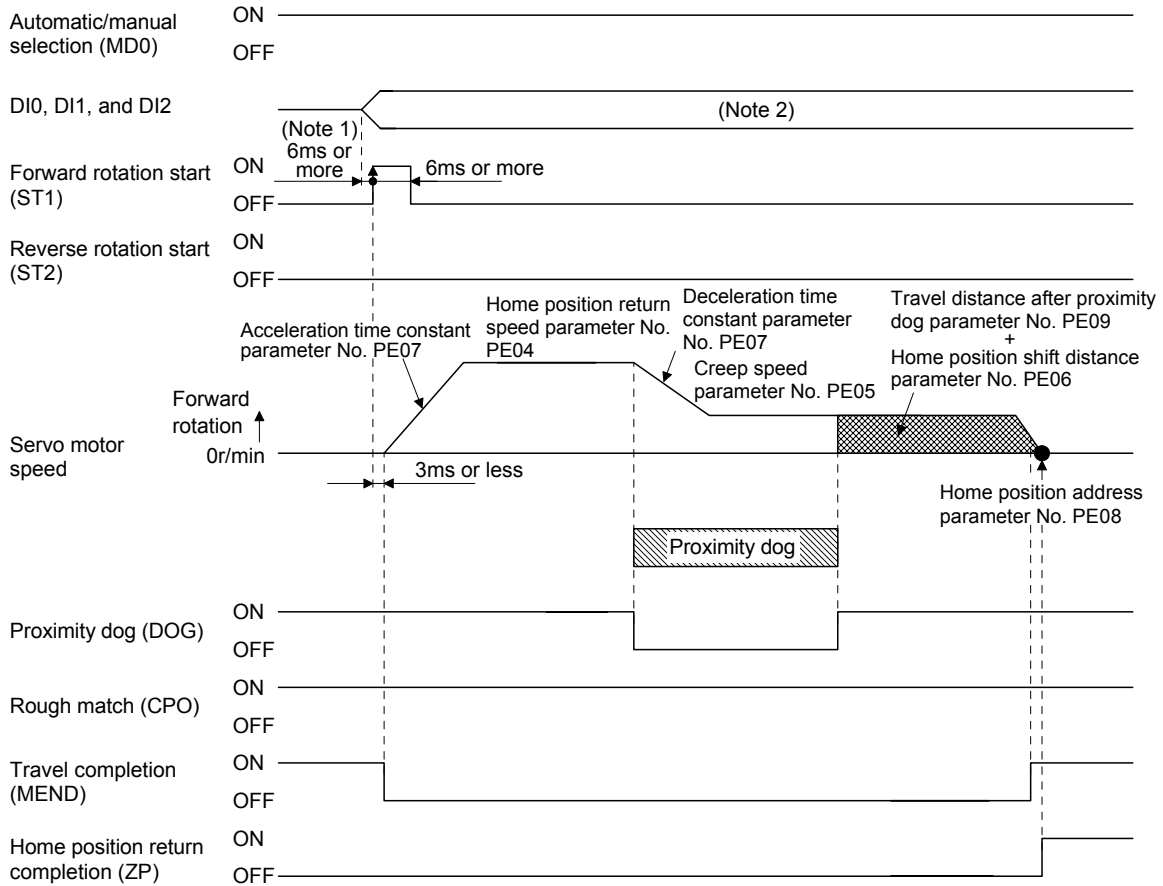

Note 1. External input signal detection delays by the input filter setting time of parameter No. PD19. Additionally, make up a sequence that changes DI0, DI1 and DI2 ahead of time by considering delays in output signal sequence from the controller and variations of a signal change due to hardware.

- Point table method: Select the home position return mode by turning OFF DI0, DI1 and DI2.
- Program method: Select a program that has the home position return "ZRT" command.

The set value in parameter No. PE08 (home position return position data) is applied as position address at the time of the home position return being completed.

13. POSITIONING MODE

13.6.9 Count type front end reference home position return

POINT
<ul style="list-style-type: none"> This home position return method depends on the timing of reading the proximity dog (DOG) that has detected the front end of a proximity dog. Hence, if a home position return is made at the home position return speed of 100r/min, an error of ± 400 pulses will occur in the home position. The error of the home position is larger as the home position return speed is higher.

The position where the axis, which had started decelerating at the front end of a proximity dog, has moved the after-proximity dog travel distance and home position shift distance is defined as a home position. A home position return that does not depend on the Z-phase signal can be made. The home position may change if the home position return speed varies.

(1) Devices and parameters

Set the input devices and parameters as indicated below.

Item	Device/Parameter used	Description
Manual home position return mode selection	Automatic/manual selection (MD0)	Turn MD0 ON.
	Point table No./Program No. selection 1 to 3 (DI0 to DI2)	Point table method: Select the home position return mode by turning OFF DI0, DI1 and DI2. Program method: Select a program that has the home position return "ZRT" command.
Count type dog front end reference home position return	Parameter No. PE03	<input type="checkbox"/> <input type="checkbox"/> <input type="checkbox"/> 6: Select the count type dog front end reference.
Home position return direction	Parameter No. PE03	Refer to section 13.6.1 (2) and select the home position return direction.
Dog input polarity	Parameter No. PE03	Refer to section 13.6.1 (2) and select the dog input polarity.
Home position return speed	Parameter No. PE04	Set the speed till the dog is detected.
Creep speed	Parameter No. PE05	Set the speed after the dog is detected.
Home position shift distance	Parameter No. PE06	Set when the home position is moved from where the axis has passed the proximity dog front end.
Travel distance after proximity dog	Parameter No. PE09	
Home position return acceleration/deceleration time constants	Parameter No. PE07	Set the acceleration/deceleration time constants during a home position return.
Home position return position data	Parameter No. PE08	Set the current position at home position return completion.

13. POSITIONING MODE

(2) Timing chart

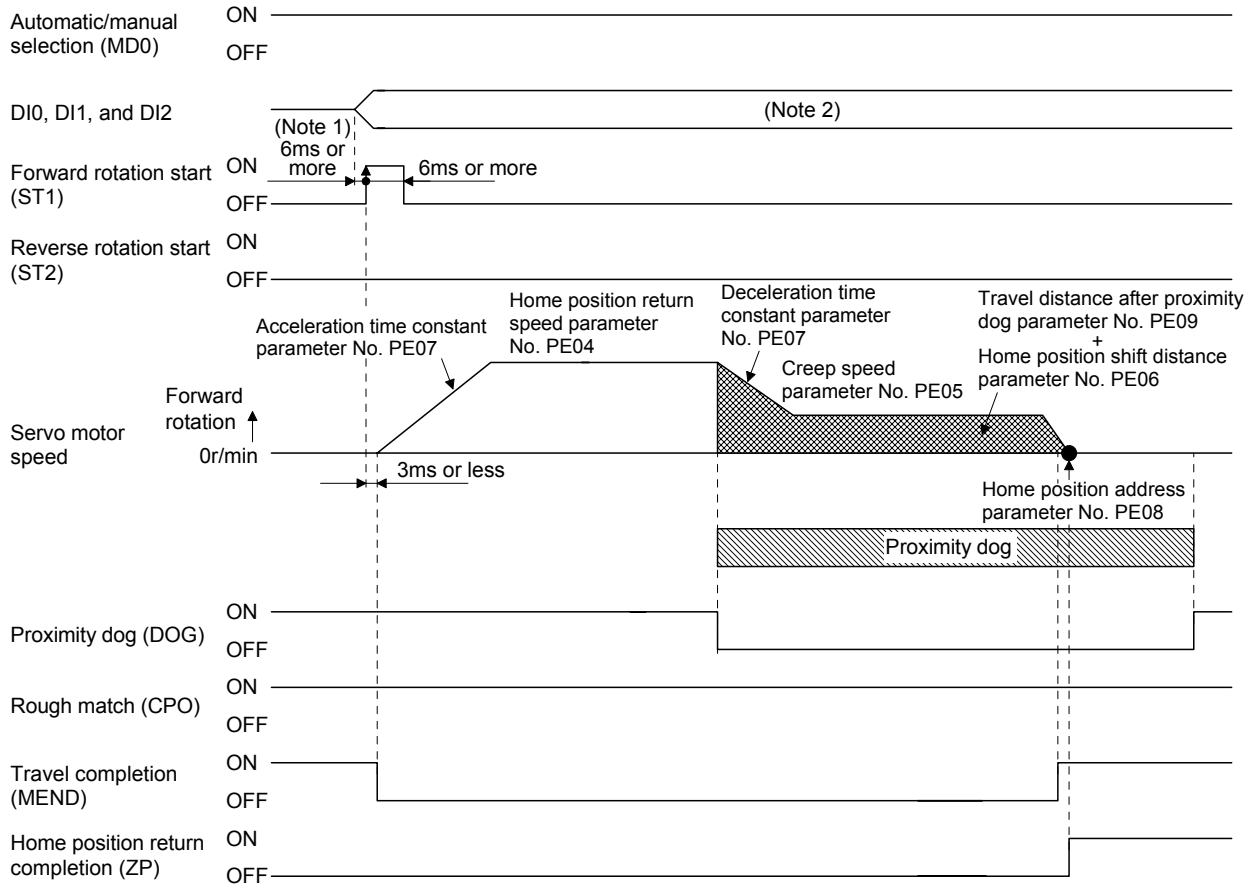

Note 1. External input signal detection delays by the input filter setting time of parameter No. PD19. Additionally, make up a sequence that changes DI0, DI1 and DI2 ahead of time by considering delays in output signal sequence from the controller and variations of a signal change due to hardware.

- Point table method: Select the home position return mode by turning OFF DI0, DI1 and DI2.
- Program method: Select a program that has the home position return "ZRT" command.

The set value in parameter No. PE08 (home position return position data) is applied as position address at the time of the home position return being completed.

13. POSITIONING MODE

13.6.10 Dog cradle type home position return

The position where the first Z-phase signal is issued after detection of the proximity dog front end can be defined as a home position.

(1) Devices and parameters

Set the input devices and parameters as indicated below.

Item	Device/Parameter used	Description
Manual home position return mode selection	Automatic/manual selection (MD0)	Turn MD0 ON.
	Point table No./Program No. selection 1 to 3 (DI0 to DI2)	Point table method: Select the home position return mode by turning OFF DI0, DI1 and DI2. Program method: Select a program that has the home position return "ZRT" command.
Dog cradle type home position return	Parameter No. PE03	<input type="checkbox"/> <input type="checkbox"/> <input type="checkbox"/> 7: Select the dog cradle type.
Home position return direction	Parameter No. PE03	Refer to section 13.6.1 (2) and select the home position return direction.
Dog input polarity	Parameter No. PE03	Refer to section 13.6.1 (2) and select the dog input polarity.
Home position return speed	Parameter No. PE04	Set the speed till the dog is detected.
Creep speed	Parameter No. PE05	Set the speed after the dog is detected.
Home position shift distance	Parameter No. PE06	Set when the home position is moved from the Z-phase signal position.
Home position return acceleration/deceleration time constants	Parameter No. PE07	Set the acceleration/deceleration time constants during a home position return.
Home position return position data	Parameter No. PE08	Set the current position at home position return completion.

13. POSITIONING MODE

(2) Timing chart

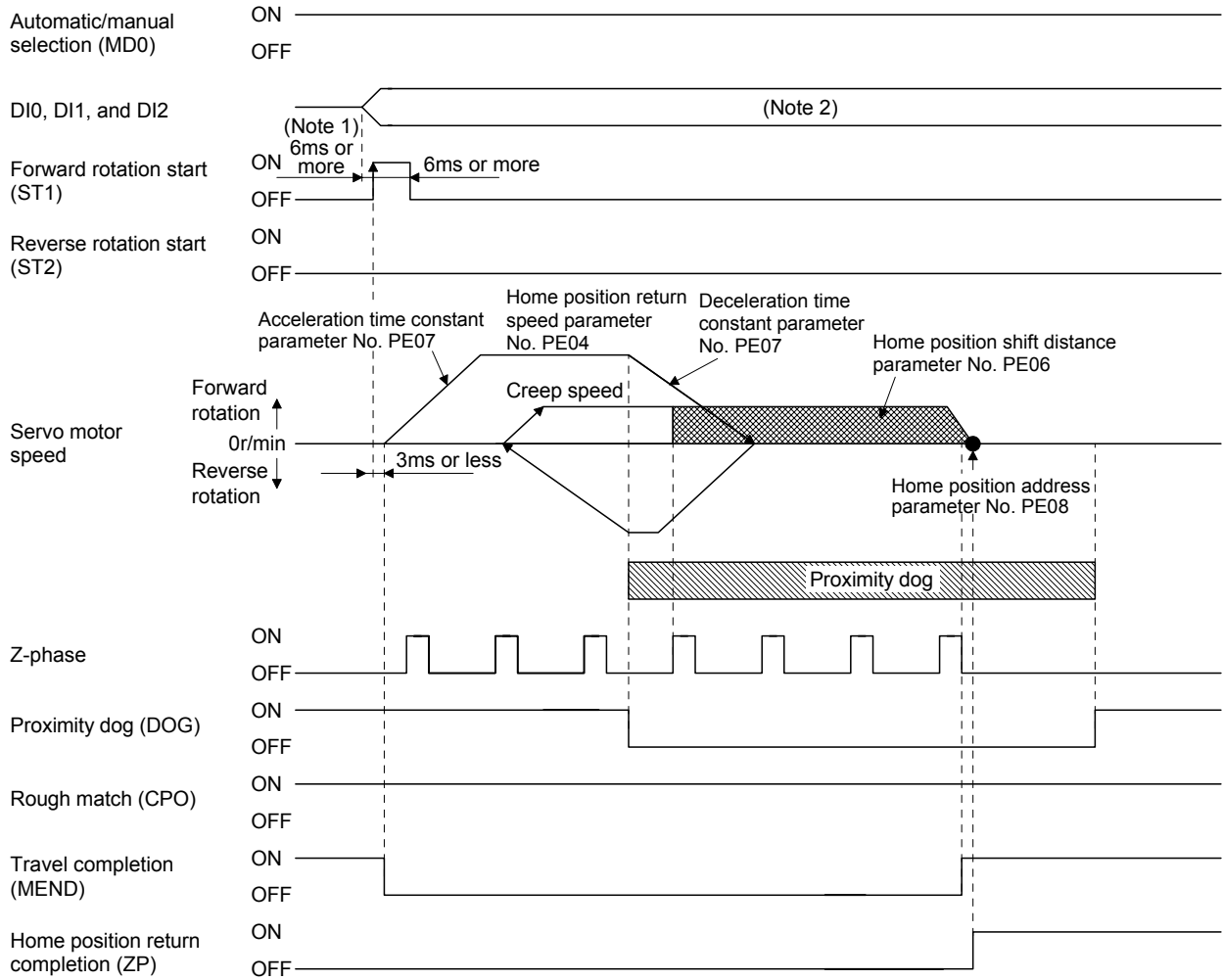

Note 1. External input signal detection delays by the input filter setting time of parameter No. PD19. Additionally, make up a sequence that changes DI0, DI1 and DI2 ahead of time by considering delays in output signal sequence from the controller and variations of a signal change due to hardware.

- Point table method: Select the home position return mode by turning OFF DI0, DI1 and DI2.
Program method: Select a program that has the home position return "ZRT" command.

The set value in parameter No. PE08 (home position return position data) is applied as position address at the time of the home position return being completed.

13. POSITIONING MODE

13.6.11 Home position return automatic return function

If the current position is on or beyond the proximity dog in the home position return using the proximity dog, this function starts home position return after making a return to the position where the home position return can be made.

(1) When the current position is on the proximity dog

When the current position is on the proximity dog, an automatic return is made before home position return.

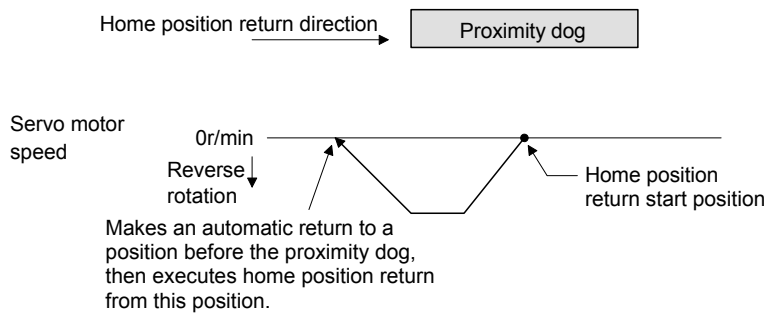

(2) When the current position is beyond the proximity dog

The current position moves in the home return direction at a start. When the stroke end (LSP or LSN) is detected, the position moves in the opposite direction. The motion stops when the position passes the front end of the proximity dog. Then, a home position return is resumed from this position. If the proximity dog is not detected, the motion stops where the opposite side of the stroke end is detected, and home position return incomplete warning (90.2) occurs.

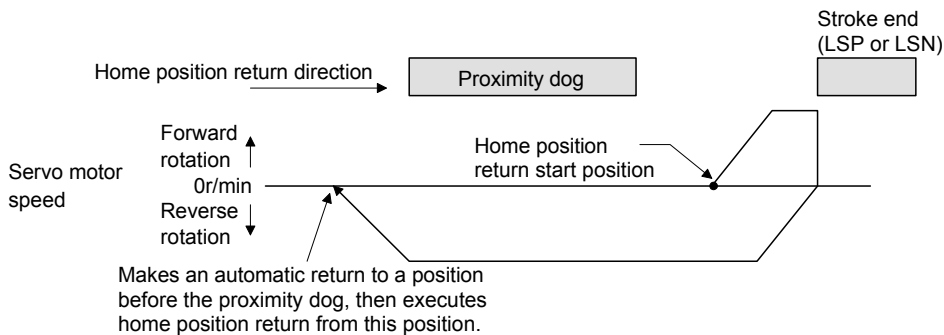

Software limit cannot be used with these functions.

13. POSITIONING MODE

13.7 Parameters



CAUTION

- Never adjust or change the parameter values extremely as it will make operation instable.
- If a fixed value is indicated in a digit of a parameter, do not change the fixed value.

POINT

- This chapter describes the parameters exclusively used for positioning mode. Refer to chapter 4 for other parameters.

In this servo amplifier, the parameters are classified into the following groups on a function basis.

Parameter group	Main description
Basic setting parameters (No. PA □□)	Make basic setting with these parameters when using this servo amplifier in the position control mode.
Gain/Filter parameters (No. PB □□)	Use these parameters when making gain adjustment manually.
Extension setting parameters (No. PC □□)	Use these parameters mainly when using this servo amplifier in the internal speed control mode or in the internal torque control mode.
I/O setting parameters (No. PD □□)	Use these parameters when changing the I/O signals of the servo amplifier.
Positioning setting parameters (No. PE □□)	Use these parameters only for the positioning mode.

13. POSITIONING MODE

13.7.1 Basic setting parameters (No. PA□□)

POINT
<ul style="list-style-type: none"> ▪ For any parameter whose symbol is preceded by *, set the parameter value and switch power off once, then switch it on again to make that parameter setting valid. ▪ Never change parameters for manufacturer setting.

(1) Parameter list

No.	Symbol	Name	Initial value	Unit	Reference
PA01	*STY	Control mode	000h		Section 4.1.3
PA02	*REG	Regenerative option	000h		Section 4.1.4
PA03		For manufacturer setting	000h		
PA04	*AOP1	Tough drive function selection	000h		Section 4.1.5
PA05	*FBP	Number of virtual pulses per revolution	100	×100 pulse/rev	(2) in this section
PA06	*CMX	Electronic gear numerator (Virtual pulse multiplying factor numerator)	1		(3) in this section
PA07	*CDV	Electronic gear denominator (Virtual pulse multiplying factor denominator)	1		
PA08	ATU	Auto tuning mode	001h		Section 4.1.8
PA09	RSP	Auto tuning response	6		Section 4.1.8
PA10	INP	In-position range	100	μm (Note)	Section 4.1.9
PA11	TLP	Forward torque limit	100	%	Section 4.1.10
PA12	TLN	Reverse torque limit	100	%	Section 4.1.10
PA13		This parameter is not used. Do not change this value by any means.	000h		
PA14	*POL	Rotation direction selection	0		(4) in this section
PA15	*ENR	Encoder output pulses	4000	pulse/rev	Section 4.1.13
PA16	*ENR2	Encoder output pulse electronic gear	0		Section 4.1.13
PA17		For manufacturer setting	000h		
PA18			000h		
PA19	*BLK	Parameter writing inhibit	00Eh		Section 4.1.2

Note. The setting range is the same although the unit differs from that of the position control mode.

13. POSITIONING MODE

(2) Number of virtual pulses per servo motor revolution

Parameter			Initial value	Setting range	Unit
No.	Symbol	Name			
PA05	*FBP	Number of virtual pulses per revolution	100	0, 100 to 500	× 100 pulse/rev

	<p>CAUTION</p> <ul style="list-style-type: none"> When this parameter is changed, turn off and on the power before starting the operation. Otherwise, the set value will not be validated, causing an unexpected operation.
---	---

<p>POINT</p> <ul style="list-style-type: none"> This parameter is made valid when power is switched off, then on after setting.

Set the number of virtual pulses necessary to rotate the servo motor one turn.

When parameter No. PA05 is set to "100 (10000[pulse/rev])" (initial value), the number of pulses necessary to rotate the servo motor one turn is 10000 pulses. When parameter No. PA05 is set to "0", the number of pulses necessary to rotate the servo motor one turn equals to the encoder resolution of the servo motor.

Parameter No. PA05 setting	Description
0	Servo motor encoder resolution [pulse/rev]
100 to 500	Number of virtual pulses necessary to rotate the servo motor one turn [× 100 pulse/rev]

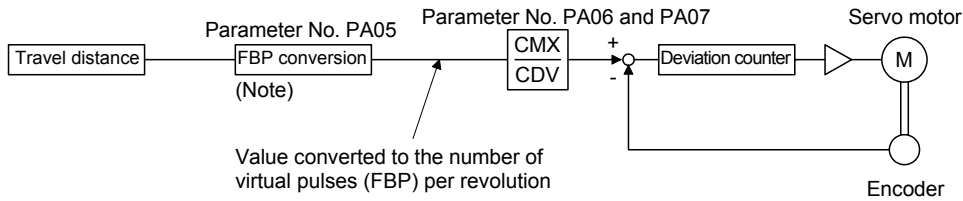

Note. This process converts the number of the virtual pulses required to rotate the servo motor one turn to the value set in parameter No. PA05.

13. POSITIONING MODE

(3) Electronic gear

Parameter			Initial value	Setting range	Unit
No.	Symbol	Name			
PA06	*CMX	Electronic gear numerator (Virtual pulse multiplying factor numerator)	1	1 to 65535	
PA07	*CDV	Electronic gear denominator (Virtual pulse multiplying factor denominator)	1	1 to 65535	



CAUTION

▪ Incorrect setting may cause unexpectedly fast rotation, resulting injury.

POINT

- In the positioning mode, this parameter is made valid when power is switched off, then on after setting.
- The setting range of the electronic gear is as follows. If you set any value outside this range, a parameter error (37.1) occurs.

Setting range of the electronic gear: Min. value < $\frac{CMX}{CDV}$ < Max. value

Parameter No. PA05	Min. value	Max. value
100 (10000[pulse/rev])	1/131	76
200 (20000[pulse/rev])	1/65	152
300 (30000[pulse/rev])	1/43	228
360 (36000[pulse/rev])	1/36	274
400 (40000[pulse/rev])	1/32	305
500 (50000[pulse/rev])	1/26	381
0 (servo motor encoder resolution)	1/10	1000

13. POSITIONING MODE

(a) Concept of electronic gear

Adjust the electronic gear (parameters No. PA06 and PA07) to make the servo amplifier setting match the travel distance of the machine. Also, by changing the electronic gear value, the machine can be moved at any multiplication ratio to the travel distance set in the servo amplifier.

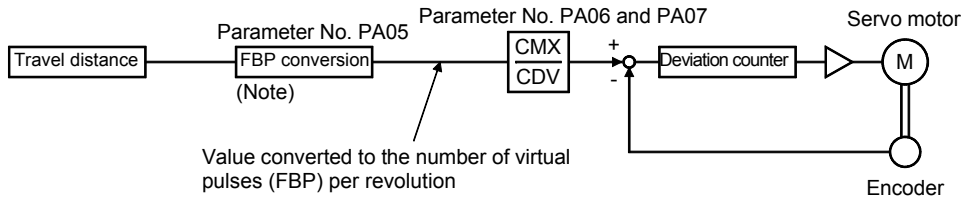

Note. This process converts the number of the virtual pulses required to rotate the servo motor one turn to the value set in parameter No. PA05.

$$\frac{CMX}{CDV} = \frac{\text{Parameter No. PA06}}{\text{Parameter No. PA07}}$$

The following setting examples are used to explain how to calculate the electronic gear.

POINT
<ul style="list-style-type: none"> The following specification symbols are required to calculate the electronic gear Pb : Ballscrew lead [mm] 1/n : Reduction ratio ΔS : Travel distance per servo motor revolution [$\mu\text{m}/\text{rev}$] $\Delta \theta$: Angle per revolution [$0.001^\circ/\text{rev}$]

(b) Setting example

1) Ballscrew setting example

Machine specifications

Ballscrew lead Pb = 10 [mm]

Reduction ratio: $1/n = Z_1/Z_2 = 1/2$

Z₁: Number of gear cogs on servo motor side

Z₂: Number of gear cogs on load side

Number of virtual pulses per revolution: 10000 [pulse/rev]

$$\frac{CMX}{CDV} = \frac{10000}{\Delta S} = \frac{10000}{1/n \cdot Pb \cdot 1000} = \frac{10000}{1/2 \cdot 10 \cdot 1000} = \frac{2}{1}$$

Hence, set 2 to CMX and 1 to CDV.

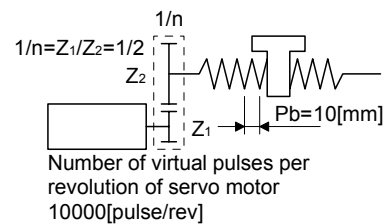

13. POSITIONING MODE

2) Conveyor setting example
 0.001° is set to be 1 μm.

Machine specifications

Table : 360° /rev
 Reduction ratio : 1/n=P1/P2=625/12544
 P1: Pulley diameter on servo motor side
 P2: Pulley diameter on load side
 Number of virtual pulses per revolution: 36000 [pulse/rev]

Number of virtual pulses per revolution of servo motor
 36000[pulse/rev]

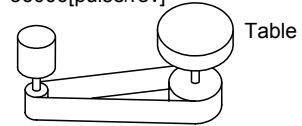

Timing belt: 625/12544

$$\frac{CMX}{CDV} = \frac{36000}{\Delta\theta} = \frac{36000}{625/12544 \cdot 360 \cdot 1000} = \frac{6272}{3125}$$

POINT
<ul style="list-style-type: none"> In the linear or rotary operation, setting the following values in the number of virtual pulses per revolution (parameter No. PA05) simplifies the setting values of the electronic gear (parameter No. PA06, PA07). Liner operation: 100 (10000[pulse/rev]) Rotary operation: 360 (36000[pulse/rev])

(4) Selection of servo motor rotation direction

Parameter			Initial value	Setting range	Unit
No.	Symbol	Name			
PA14	*POL	Rotation direction selection	0	0, 1	

POINT
<ul style="list-style-type: none"> This parameter is made valid when power is switched off, then on after setting. In program method, ST2 can be used only for JOG operation in the test mode.

Select the servo motor rotation direction when the forward rotation start (ST1) or reverse rotation direction (ST2) is turned ON.

Parameter No. PA14 setting	Servo motor rotation direction	
	Forward rotation start (ST1) ON	Reverse rotation start (ST2) ON
0	CCW rotation (address incremented)	CW rotation (address decremented)
1	CW rotation (address incremented.)	CCW rotation (address decremented)

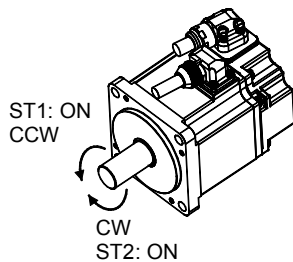

Parameter No. PA14: 0

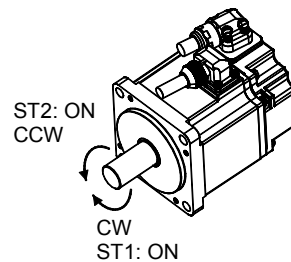

Parameter No. PA14: 1

13. POSITIONING MODE

13.7.2 Gain/filter parameters (No. PB□□)

POINT
<ul style="list-style-type: none"> ▪ For any parameter whose symbol is preceded by *, set the parameter value and switch power off once, then switch it on again to make that parameter setting valid. ▪ Set any parameter with [Applied] written in the name column when using an advanced function. ▪ Never change parameters for manufacturer setting.

No.	Symbol	Name	Initial value	Unit	Reference
PB01	FILT	Adaptive tuning mode (Adaptive filter II)	000h		Section 4.2.2
PB02	VRFT	Vibration suppression control tuning mode (Advanced vibration suppression control)	000h		
PB03		This parameter is not used. Do not change this value by any means.			
PB04	FFC	Feed forward gain [Applied]	0	%	Section 4.2.2
PB05		For manufacturer setting	500		
PB06	GD2	Load to motor inertia moment ratio	7.0	Multiplier	Section 4.2.2
PB07	PG1	Model loop gain	24	rad/s	
PB08	PG2	Position loop gain	37	rad/s	
PB09	VG2	Speed loop gain	823	rad/s	
PB10	VIC	Speed integral compensation	33.7	ms	
PB11	VDC	Speed differential compensation [Applied]	980		
PB12	OVA	Overshoot amount compensation [Applied]	0	%	
PB13	NH1	Machine resonance suppression filter 1	4500	Hz	
PB14	NHQ1	Notch shape selection 1	000h		
PB15	NH2	Machine resonance suppression filter 2	4500	Hz	
PB16	NHQ2	Notch shape selection 2	000h		
PB17		Automatic setting parameter			
PB18	LPF	Low-pass filter setting [Applied]	3141	rad/s	Section 4.2.2
PB19	VRF1	Vibration suppression control vibration frequency setting [Applied]	100.0	Hz	
PB20	VRF2	Vibration suppression control resonance frequency setting [Applied]	100.0	Hz	
PB21		For manufacturer setting	0		
PB22			0		
PB23	VFBF	Low-pass filter selection [Applied]	000h		Section 4.2.2
PB24		For manufacturer setting	000h		
PB25	*BOP1	Function selection B-1 [Applied]	000h		Section 4.2.2
PB26	*CDP	Gain changing selection [Applied]	000h		
PB27	CDL	Gain changing condition [Applied]	10		
PB28	CDT	Gain changing time constant [Applied]	1	ms	
PB29	GD2B	Gain changing load to motor inertia moment ratio [Applied]	7.0	Multiplier	
PB30	PG2B	Gain changing position loop gain [Applied]	37	rad/s	
PB31	VG2B	Gain changing speed loop gain [Applied]	823	rad/s	
PB32	VICB	Gain changing speed integral compensation [Applied]	33.7	ms	
PB33	VRF1B	Gain changing vibration suppression control vibration frequency setting [Applied]	100.0	Hz	
PB34	VRF2B	Gain changing vibration suppression control resonance frequency setting [Applied]	100.0	Hz	
PB35		For manufacturer setting	0		
PB36			0		
PB37			100		
PB38	NH3	Machine resonance suppression filter 3	4500	Hz	Section 4.2.2
PB39	NHQ3	Notch shape selection 3	000h		

13. POSITIONING MODE

No.	Symbol	Name	Initial value	Unit	Reference
PB40		For manufacturer setting	111h		
PB41			20		
PB42			000h		
PB43			000h		
PB44			000h		
PB45			000h		
PB46			000h		
PB47			000h		
PB48			000h		
PB49			000h		
PB50			000h		

13. POSITIONING MODE

13.7.3 Extension setting parameters (No. PC□□)

POINT
<ul style="list-style-type: none"> ▪ For any parameter whose symbol is preceded by *, set the parameter value and switch power off once, then switch it on again to make that parameter setting valid. ▪ Set any parameter with [Applied] written in the name column when using an advanced function. ▪ Never change parameters for manufacturer setting.

(1) Parameter list

No.	Symbol	Name	Initial value	Unit	Reference
PC01		This parameter is not used. Do not change this value by any means.	0		
PC02			0		
PC03	STC	S-pattern acceleration/deceleration time constant	0	ms	(2) in this section
PC04		This parameter is not used. Do not change this value by any means.	0		
PC05			0		
PC06			100		
PC07			500		
PC08			1000		
PC09	MBR	Electromagnetic brake sequence output	100	ms	Section 4.3.2
PC10	ZSP	Zero speed	50	r/min	
PC11	*BPS	Alarm history clear	000h		
PC12		This parameter is not used. Do not change this value by any means.	0		
PC13	*ENRS	Encoder output pulses selection	000h		Section 4.3.2
PC14	TL2	Internal torque limit 2 [Applied]	100	%	
PC15	ERZL	Error excessive alarm detection level	3.0	rev	
PC16		For manufacturer setting	30		
PC17	*OSL	Overspeed alarm detection level	0	r/min	Section 4.3.2
PC18		For manufacturer setting	1000		
PC19			0		
PC20			000h		
PC21			001h		
PC22	*COP1	Function selection C-1 [Applied]	000h		Section 4.3.2
PC23		This parameter is not used. Do not change this value by any means.	000h		
PC24	*COP3	Function selection C-3 [Applied]	000h		
PC25	*COP4	Function selection C-4 [Applied]	000h		Section 4.3.2
PC26	ALDT	Detailed setting of overload tough drive [Applied]	200	×10ms	
PC27	OSCL	Detailed setting of vibration tough drive [Applied]	50	%	
PC28	CVAT	Detailed setting of instantaneous power failure tough drive [Applied]	3	×10ms	
PC29	*COP5	Function selection C-5 [Applied]	000h		
PC30		This parameter is not used. Do not change this value by any means.	000h		
PC31			200		
PC32			300		
PC33			500		
PC34			800		

13. POSITIONING MODE

No.	Symbol	Name	Initial value	Unit	Reference
PC35		For manufacturer setting	000h		
PC36			0		
PC37			0		
PC38			0		
PC39			0		
PC40			0		
PC41			000h		
PC42			0		
PC43			000h		
PC44	RECT		Drive recorder alarm specifying		
PC45		For manufacturer setting	000h		
PC46			000h		
PC47			000h		
PC48			000h		
PC49			000h		
PC50			000h		
PC51			000h		
PC52			000h		
PC53			000h		
PC54			000h		
PC55			000h		
PC56			000h		
PC57			000h		
PC58			000h		
PC59			000h		
PC60			000h		
PC61			000h		
PC62			000h		
PC63			000h		
PC64			000h		

13. POSITIONING MODE

(2) List of details

No.	Symbol	Name and function	Initial value	Setting range	Unit
PC03	STC	<p>S-pattern acceleration/deceleration time constant</p> <p>In servo operation, linear acceleration/deceleration is usually made. By setting the S-pattern acceleration/deceleration time constant (parameter No.PC03), a smooth start/stop can be made. When the S-pattern time constant is set, smooth positioning is executed as shown below. Note that the time equivalent to the S-pattern time constant setting increases until the travel completion (MEND).</p> <p>Ta: Time until preset speed is reached Tb: Time until stop Ts: S-pattern acceleration/deceleration time constant (parameter No. PC03) Setting range 0 to 100ms (S-pattern acceleration/deceleration time constant at setting value 101 to 1000 is 100ms)</p> <p>In the program method, S-pattern acceleration/deceleration time constant of STD command is valid during the time from the STD command start to the program end. For other than that, S-pattern acceleration/deceleration time constant of parameter No. PC03 is valid.</p>	0	0 to 100 101 to 1000	ms

13. POSITIONING MODE

13.7.4 I/O setting parameters (No. PD□□)

POINT
<ul style="list-style-type: none"> ▪ For any parameter whose symbol is preceded by *, set the parameter value and switch power off once, then switch it on again to make that parameter setting valid. ▪ Never change parameters for manufacturer setting.

(1) Parameter list

No.	Symbol	Name	Initial value	Unit	Reference
PD01	*DIA1	Input signal automatic ON selection 1	0000h		Section 4.4.2
PD02	*DI0	Input signal device selection 0 (CN1-23, CN1-25)	262Dh		
PD03	*DI1-1	Input signal device selection 1L (CN1-3)	0303h		
PD04	*DI1-2	Input signal device selection 1H (CN1-3)	2003h		
PD05	*DI2-1	Input signal device selection 2L (CN1-4)	0202h		
PD06	*DI2-2	Input signal device selection 2H (CN1-4)	0202h		
PD07	*DI3-1	Input signal device selection 3L (CN1-5)	0D06h		
PD08	*DI3-2	Input signal device selection 3H (CN1-5)	2C0Dh		
PD09	*DI4-1	Input signal device selection 4L (CN1-6)	070Ah		
PD10	*DI4-2	Input signal device selection 4H (CN1-6)	0707h		
PD11	*DI5-1	Input signal device selection 5L (CN1-7)	080Bh		
PD12	*DI5-2	Input signal device selection 5H (CN1-7)	0808h		
PD13	*DI6-1	Input signal device selection 6L (CN1-8)	0505h		
PD14	*DI6-2	Input signal device selection 6H (CN1-8)	0505h		
PD15	*DO1	Output signal device selection 1 (CN1-9)	0003h		
PD16	*DO2	Output signal device selection 2 (CN1-10)	0004h		
PD17	*DO3	Output signal device selection 3 (CN1-11)	0002h		
PD18	*DO4	Output signal device selection 4 (CN1-12)	0005h		
PD19	*DIF	Input filter setting	0002h		
PD20	*DOP1	Function selection D-1	0000h		(2) in this section
PD21		For manufacturer setting	0000h		
PD22	*DOP3	Function selection D-3	0000h		Section 4.4.2
PD23		For manufacturer setting	0000h		
PD24	*DOP5	Function selection D-5	0000h		Section 4.4.2
PD25		For manufacturer setting	0000h		
PD26			0000h		

13. POSITIONING MODE

(2) List of details

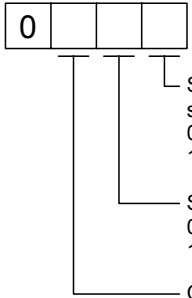
No.	Symbol	Name and function	Initial value	Setting range	Unit
PD20	*DOP1	<p>Function selection D-1</p> <p>Select the stop processing at LSP/LSN OFF or when the software limit is detected, the base circuit status at reset (RES) ON and the operation during tough drive (MTTR).</p>  <p>0: Sudden stop (Home position is not erased.) 1: Slow stop (Home position is not erased.)</p> <p>0: Base circuit switched off 1: Base circuit not switched off</p> <p>0: MTTR turns ON during the instantaneous power failure tough drive 1: MTTR turns ON during the overload tough drive or the instantaneous power failure tough drive</p>	0000h	Refer to the name and function filed.	

13. POSITIONING MODE

13.7.5 Positioning setting parameters (No. PE□□)

POINT
<ul style="list-style-type: none"> ▪ For any parameter whose symbol is preceded by *, set the parameter value and switch power off once, then switch it on again to make that parameter setting valid. ▪ Never change parameters for manufacturer setting.

(1) Parameter list

No.	Symbol	Name	Initial value	Unit	Reference
PE01	*CTY	Command mode selection	0000h		(2) in this section
PE02	*FTY	Feeding function selection	0000h		
PE03	*ZTY	Home position return type	0010h		
PE04	ZRF	Home position return speed	500	r/min	
PE05	CRF	Creep speed	10	r/min	
PE06	ZST	Home position shift distance	0	μm	
PE07	FTS	Home position return/JOG operation acceleration/deceleration time constants	100	ms	
PE08	*ZPS	Home position return position data	0	×10 ^{STM} μm	
PE09	DCT	Travel distance after proximity dog	1000	×10 ^{STM} μm	
PE10	ZTM	Stopper type home position return stopper time	100	ms	
PE11	ZTT	Stopper type home position return torque limit value	15	%	
PE12	CRP	Rough match output range	0	×10 ^{STM} μm	
PE13	JOG	JOG speed	100	r/min	
PE14	OUT1	OUT1 output time selection This parameter is used only for the program method. This is not used in the point table method.	0	ms	
PE15	*BKC	Backlash compensation	0	pulse	
PE16	*LMPL	Software limit +	0	×10 ^{STM} μm	
PE17	*LMPH		0		
PE18	*LMNL	Software limit -	0	×10 ^{STM} μm	
PE19	*LMNH		0		
PE20	*LPPL	Position range output address +	0	×10 ^{STM} μm	
PE21	*LPPH		0		
PE22	*LNPL	Position range output address -	0	×10 ^{STM} μm	
PE23	*LNPH		0		
PE24	*EOP1	Function selection E-1	0000h		
PE25		For manufacturer setting	10		
PE26			100		
PE27			0000h		
PE28			0000h		

13. POSITIONING MODE

(2) List of details

No.	Symbol	Name and function	Initial value	Setting range	Unit																											
PE01	*CTY	<p>Command mode selection Select the command system.</p> <div style="border: 1px solid black; display: inline-block; padding: 2px;">0 0 0</div> <p>Selection of command system (Refer to section 13.3 and 13.4) 0: Absolute value command system 1: Incremental value command system</p>	0000h	Refer to the name and function filed.																												
PE02	*FTY	<p>Feeding function selection Select the feed length multiplication and the manual pulse generator input multiplication.</p> <div style="border: 1px solid black; display: inline-block; padding: 2px;">0 0</div> <table border="1" style="margin-top: 10px;"> <thead> <tr> <th rowspan="2">Set value</th> <th rowspan="2">Feed length multiplication (STM) [Multiplier]</th> <th rowspan="2">Feed unit [μm]</th> <th colspan="2">Position data input range [mm]</th> </tr> <tr> <th>Absolute value command system</th> <th>Incremental value command system</th> </tr> </thead> <tbody> <tr> <td>0</td> <td>1</td> <td>1</td> <td>-999.999 to +999.999</td> <td>0 to +999.999</td> </tr> <tr> <td>1</td> <td>10</td> <td>10</td> <td>-9999.99 to +9999.99</td> <td>0 to +9999.99</td> </tr> <tr> <td>2</td> <td>100</td> <td>100</td> <td>-99999.9 to +99999.9</td> <td>0 to +99999.9</td> </tr> <tr> <td>3</td> <td>1000</td> <td>1000</td> <td>-999999 to +999999</td> <td>0 to +999999</td> </tr> </tbody> </table> <p>Manual pulse generator multiplication 0: 1 time 1: 10 times 2: 100 times</p>	Set value	Feed length multiplication (STM) [Multiplier]	Feed unit [μ m]	Position data input range [mm]		Absolute value command system	Incremental value command system	0	1	1	-999.999 to +999.999	0 to +999.999	1	10	10	-9999.99 to +9999.99	0 to +9999.99	2	100	100	-99999.9 to +99999.9	0 to +99999.9	3	1000	1000	-999999 to +999999	0 to +999999	0000h	Refer to the name and function filed.	
Set value	Feed length multiplication (STM) [Multiplier]	Feed unit [μ m]				Position data input range [mm]																										
			Absolute value command system	Incremental value command system																												
0	1	1	-999.999 to +999.999	0 to +999.999																												
1	10	10	-9999.99 to +9999.99	0 to +9999.99																												
2	100	100	-99999.9 to +99999.9	0 to +99999.9																												
3	1000	1000	-999999 to +999999	0 to +999999																												
PE03	*ZTY	<p>Home position return type Select the home position return type, home position return direction and proximity dog input polarity. (Refer to section 13.6.)</p> <div style="border: 1px solid black; display: inline-block; padding: 2px;">0</div> <p>Home position return type 0: Dog type 1: Count type 2: Data set type 3: Stopper type 4: Home position ignorance (Servo-on position as home position) 5: Dog type rear end reference 6: Count type front end reference 7: Dog cradle type</p> <p>Home position return direction 0: Address increasing direction 1: Address decreasing direction</p> <p>Proximity dog input polarity 0: OFF indicates detection of the dog 1: ON indicates detection of the dog</p>	0010h	Refer to the name and function filed.																												
PE04	ZRF	<p>Home position return speed Used to set the servo motor speed for home position return. (Refer to section 13.6.)</p>	500	0 to permissible speed	r/min																											

13. POSITIONING MODE

No.	Symbol	Name and function	Initial value	Setting range	Unit
PE05	CRF	Creep speed Used to set the creep speed after proximity dog detection. (Refer to section 13.6.)	10	0 to permissible speed	r/min
PE06	ZST	Home position shift distance Used to set the travel distance from the home position. (Refer to section 13.6.)	0	0 to 65535	μm
PE07	FTS	Home position return/JOG operation acceleration/deceleration time constants Used to set the acceleration/deceleration time constants during a home position return or JOG operation.	100	0 to 20000	ms
PE08	*ZPS	Home position return position data Used to set the current position on completion of home position return. (Refer to section 13.6.)	0	-32768 to 32767	×10 ^{STM} μm
PE09	DCT	Travel distance after proximity dog Used to set the travel distance after proximity dog detection. (Refer to section 13.6.)	1000	0 to 65535	×10 ^{STM} μm
PE10	ZTM	Stopper type home position return stopper time In stopper type home position return, used to set the time from when the machine part is pressed against the stopper and the torque limit set in parameter No. PE11 is reached to when the home position is set. (Refer to section 13.6.6.) However, the stopper type home position return stopper time for the setting value 0 to 4 is 5ms.	100	0 to 4	ms
				5 to 1000	
PE11	ZTT	Stopper type home position return torque limit value Used to set the torque limit value relative to the max. torque in [%] in stopper type home position return. (Refer to section 13.6.6.) However, the stopper type home position return torque limit value for the setting value 0 is 1%.	15	0	%
				1 to 100	
PE12	CRP	Rough match output range Used to set the command remaining distance range where the rough match (CPO) is output.	0	0 to 65535	×10 ^{STM} μm
PE13	JOG	JOG speed Used to set the JOG speed command.	100	0 to permissible speed	r/min
PE14	OUT1	OUT1 output time selection This parameter is used only for the program method. It is not used in the point table method. Used to set the output time of OUT1. The OUT1 is turned on by OUTON program command. If "0" is set, it keeps ON.	0	0 to 20000	ms
PE15	*BKC	Backlash compensation Used to set the backlash compensation made when the command direction is reversed. This function compensates for the number of backlash pulses in the opposite direction to the home position return direction. For the home position ignorance (servo-on position as home position), this function compensates for the number of backlash pulses in the opposite direction to the first rotating direction after establishing the home position by switching ON the servo-on (SON).	0	0 to 32000	pulse

13. POSITIONING MODE

No.	Symbol	Name and function	Initial value	Setting range	Unit
PE16	LMPL	<p>Software limit +</p> <p>Used to set the address increment side software stroke limit. The software limit is made invalid if this value is the same as in "software limit -". (Refer to (4) in this section.)</p> <p>Set the same sign to parameters No. PE16 and No. PE17. Setting of different signs will result in a parameter error.</p>	0	-999999 to 999999	$\times 10^{\text{STM}} \mu\text{m}$
PE17	LMPH	<p>Set address: $\square\square\square\square\square$</p> <p>Upper three digits Lower three digits</p> <p> └─ Parameter No. PE16</p> <p> └─ Parameter No. PE17</p> <p>The software limit + is a set of upper digits and lower digits. To change the value, set in the order of lower digits to upper digits.</p>			
PE18	LMNL	<p>Software limit -</p> <p>Used to set the address decrement side software stroke limit. The software limit is made invalid if this value is the same as in "software limit +". (Refer to (4) in this section.)</p> <p>Set the same sign to parameters No. PE18 and No. PE19. Setting of different signs will result in a parameter error.</p>	0	-999999 to 999999	$\times 10^{\text{STM}} \mu\text{m}$
PE19	LMNH	<p>Set address: $\square\square\square\square\square$</p> <p>Upper three digits Lower three digits</p> <p> └─ Parameter No. PE18</p> <p> └─ Parameter No. PE19</p> <p>The software limit - is a set of upper digits and lower digits. To change the value, set in the order of lower digits to upper digits.</p>			
PE20	*LPPL	<p>Position range output address +</p> <p>Used to set the address increment side position range output address.</p> <p>Set the same sign to parameters No. PE20 and No. PE21. Setting of different signs will result in a parameter error.</p> <p>In parameters No. PE20 to PE23, set the range where position range (POT) turns on.</p>	0	-999999 to 999999	$\times 10^{\text{STM}} \mu\text{m}$
PE21	*LPPH	<p>Set address: $\square\square\square\square\square$</p> <p>Upper three digits Lower three digits</p> <p> └─ Parameter No. PE20</p> <p> └─ Parameter No. PE21</p> <p>Position range output address + is a set of upper digits and lower digits. To change the value, set in the order of lower digits to upper digits.</p>			

13. POSITIONING MODE

No.	Symbol	Name and function	Initial value	Setting range	Unit
PE22	*LNPL	Position range output address - Used to set the address decrement side position range output address. Set the same sign to parameters No. PE22 and No. PE23. Setting of different signs will result in a parameter error. Set address: $\square\square\square\square\square$ Upper three digits Lower three digits Parameter No. PE22 Parameter No. PE23	0	-999999 to 999999	$\times 10^{\text{STM}} \mu\text{m}$
PE23	*LNPH	Position range output address - is a set of upper digits and lower digits. To change the value, set in the order of lower digits to upper digits.			
PE24	*EOP1	Function selection E-1 Used to permit/inhibit editing the point table/program or to select the polarity of program input 1 (PI1). $\begin{array}{ c c c } \hline 0 & 0 & \\ \hline \end{array}$ Point table/program edit 0: Permit 1: Inhibit Polarity selection of program input 1 (PI1) This setting is used only for the program method. It is not used in the point table method. 0: Positive logic 1: Negative logic	0000h	Refer to the name and function filed.	
PE25		For manufacturer setting	10		
PE26		Do not change this value by any means.	4100		
PE27			0000h		
PE28			0000h		

(3) Rough match output

Rough match (CPO) is output when the command remaining distance reaches the value set in parameter No. PE12 (rough match output range). The setting range is 0 to 65535 [$\times 10^{\text{STM}} \mu\text{m}$].

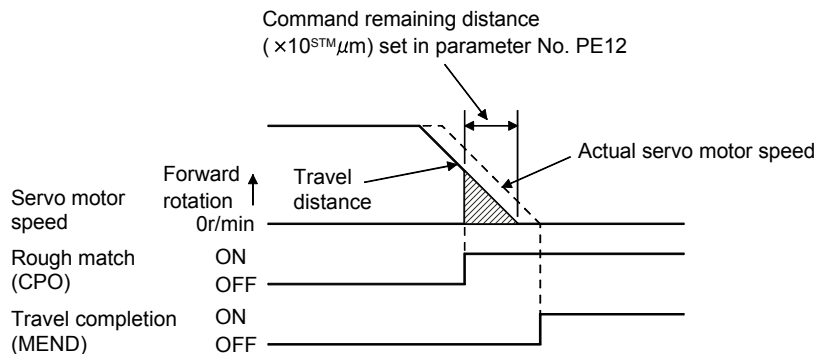

13. POSITIONING MODE

(4) Software limit

A limit stop using a software limit (parameter No. PE16 to PE19) is made as in stroke end operation. When a motion goes beyond the setting range, the motor is stopped and servo-locked. This function is made valid at power-on but made invalid during home position return. This function is made invalid when the software limit + setting is the same as the software limit - setting. A parameter error (37.1) will occur if the software limit + setting is less than the software limit - setting.

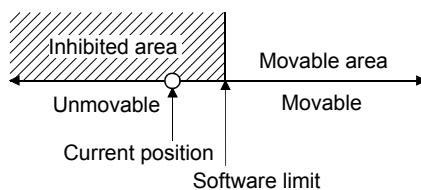

13. POSITIONING MODE

13.8 Point table setting method

This section provides the method for setting the point table by using MR Configurator.

POINT
<ul style="list-style-type: none"> Positioning mode is supported by MR Configurator with software version C4 or later. The value of the parameter No. PE02 set on the parameter setting screen is not interlocked with the STM (feed length multiplication) value on the point table list screen. Set the STM (feed length multiplication) value to the same as set in the parameter No. PE02 on the point table list screen.

Click "Positioning-data" on the menu bar, and click "Point table" on the menu.

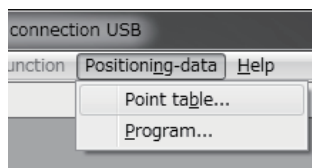

When the above choices are made, the following window appears.

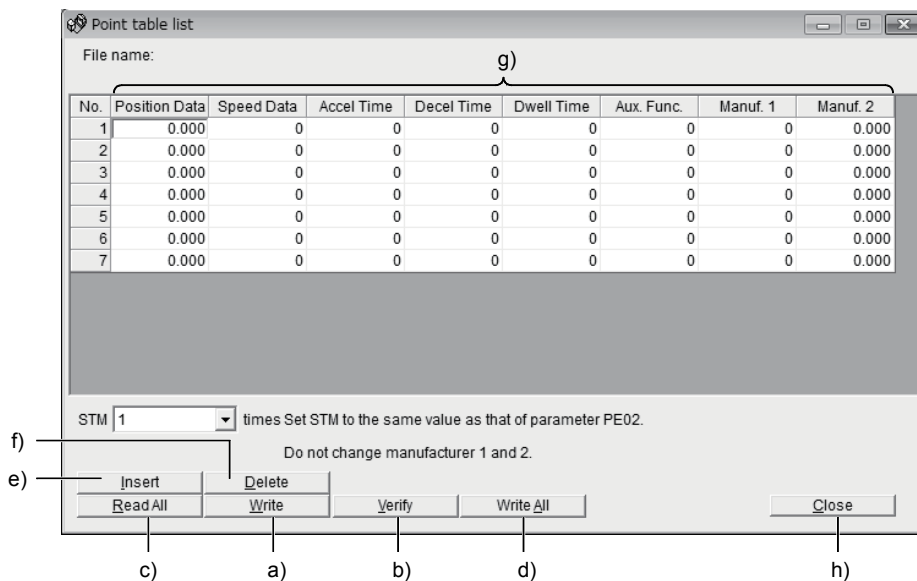

(1) Writing point table data (a)

Click the point table data changed, and click the "Write" button to write the new point table data to the servo amplifier.

(2) Verifying point table data (b)

Click the "Verify" button to verify all data being displayed and the data of the servo amplifier.

(3) Batch-reading point table data (c)

Click the "Read All" button to read and display all point table data from the servo amplifier.

(4) Batch-writing point table data (d)

Click the "Write All" button to write all point table data to the servo amplifier.

13. POSITIONING MODE

- (5) Inserting point table data (e)
Click the "Insert" button to insert one row just above the selected point table No. The rows of the selected table No. and below are shifted down.
- (6) Deleting point table data (f)
Click the "Delete" button to delete all data in the selected point table No. The rows below the selected table No. are shifted up.
- (7) Changing point table data (g)
Click the data to be changed, enter a new value into the input field, and press the enter key.
- (8) Reading point table data
Point table data in a file can be read and displayed. Click "Project" on the menu bar to read the point table data.
- (9) Saving point table data
All displayed point table data on the window can be saved. Click "Project" on the menu bar to save the point table data.
- (10) Printing point table data
All displayed point table data on the window can be printed. Click "Project" on the menu bar to print the point table data.
- (11) Closing point table data (h)
Click the "Close" button to close the window.

13. POSITIONING MODE

13.9 Program setting method

This section provides the method for setting programs using MR Configurator.

POINT
▪ Positioning mode is supported by MR Configurator with software version C4 or later.

(1) How to open the setting screen

Click "Positioning-data" on the menu bar, and click "Program" on the menu.

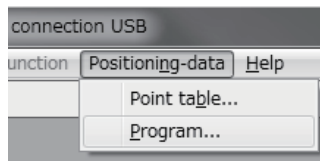

(2) Explanation of Program window

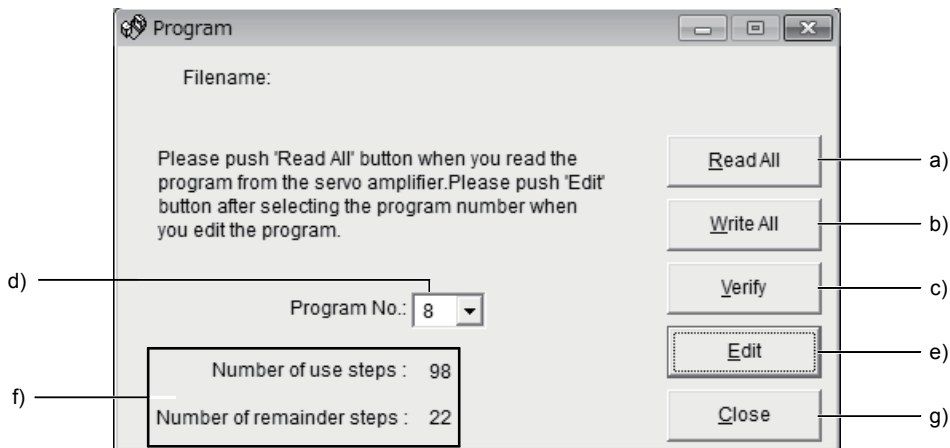

(a) Reading the program (a)

Click the "Read All" button to read the program stored in the servo amplifier.

(b) Writing the program (b)

Click the "Write All" button to write the program, whose setting has been changed, to the servo amplifier.

(c) Verifying the programs (c)

Click the "Verify" button to verify the program contents on the personal computer and the program contents of the servo amplifier.

(d) Selecting the program No. (d)

Used to select the program No. to be edited.

(e) Editing the program (e)

Used to edit the program selected in d). Click the "Edit" button to open the Program Edit window. Refer to (3) in this section for the edit screen.

(f) Reading and saving the program file

A program can be saved/read as a file. Click "Project" on the menu bar to save or read the project.

13. POSITIONING MODE

(g) Printing the program

The read and edited program can be printed. Click "Project" on the menu bar to print the program.

(h) Referring to the number of steps (f)

The numbers of steps used and remaining steps in all programs are displayed.

(i) Closing the Program Data window (g)

Click the "Close" button to close the window.

(3) Explanation of Program Edit window

Create a program in the Program Edit window.

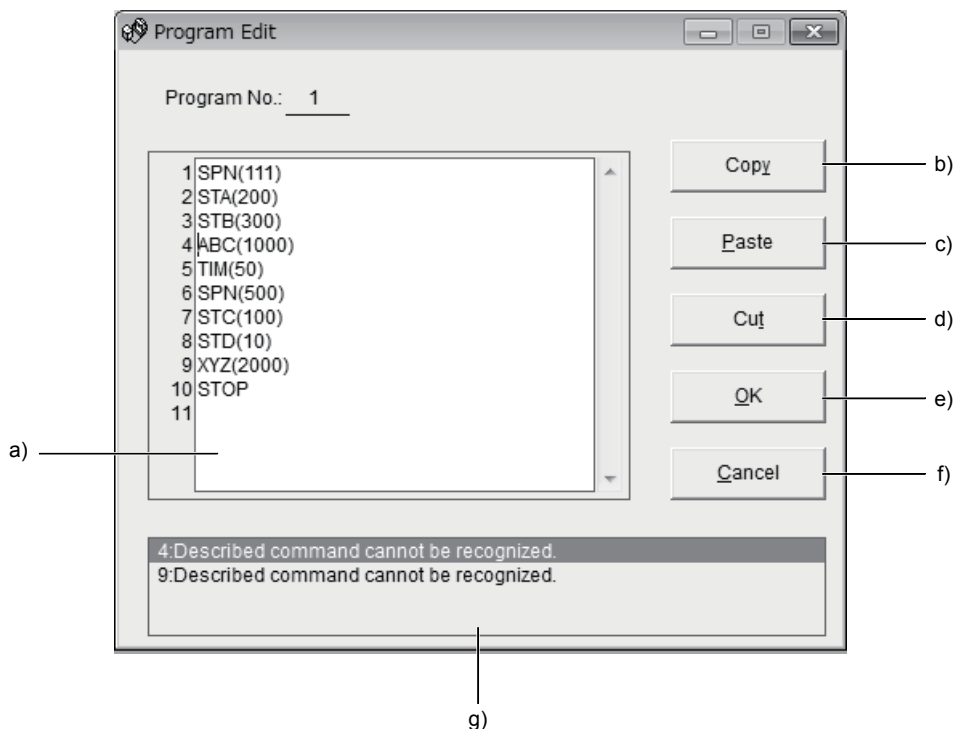

(a) Editing the program (a)

Enter commands into the program edit area (a) in a text format.

(b) Copying the text (b)

Select the text of the program edit area and click the "Copy" button to store the selected text into the clipboard.

(c) Pasting the text (c)

Click the "Paste" button to paste the text stored in the clipboard to the specified position of the program edit area.

(d) Deleting the text (d)

Select the text of the program edit area and click the "Cut" button to delete the selected text.

(e) Closing the Program Data window (e)

Click the "OK" button to execute the edit check. If the check is completed without any problem, editing will be terminated and Program Data window will close. If any problem is found, an error will be displayed.

13. POSITIONING MODE

(f) Canceling the Program Edit window (f)

Click the "Cancel" button to discard the program being edited and close the Program Edit window.

(g) Error display (g)

If a problem is found when the edit check is executed in (e), the line number and content of the error will be displayed. Click the error content to move the cursor to the corresponding line in the program.

13. POSITIONING MODE

13.10 Single-step feed usage in the test operation mode

This section provides the usage of single-step feed using MR Configurator.

POINT
<ul style="list-style-type: none">▪ The single-step feed is supported by servo amplifier with software version B0 or later, and MR Configurator with software version C4 or later.▪ The servo motor will not operate if the forced stop (EM1), forward rotation stroke end (LSP) and reverse rotation stroke end (LSN) are off. Make automatic ON setting to turn on these devices or turn on between DOCOM. (Refer to section 4.4.2.)

Operation is performed in accordance with the preset point table No./program No.
Click "Test" on the menu bar and click "Single-step Feed" on the menu.

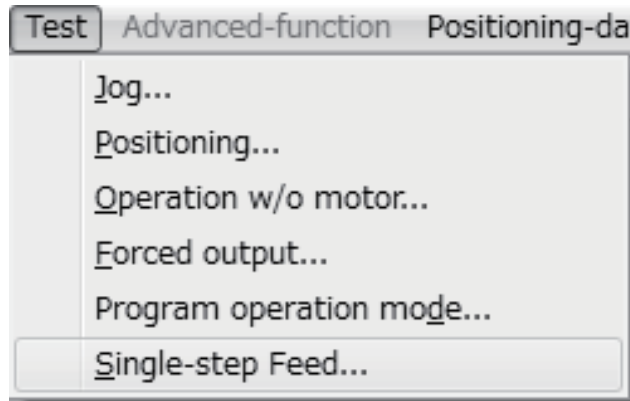

Clicking displays the confirmation window for switching to the test operation mode.

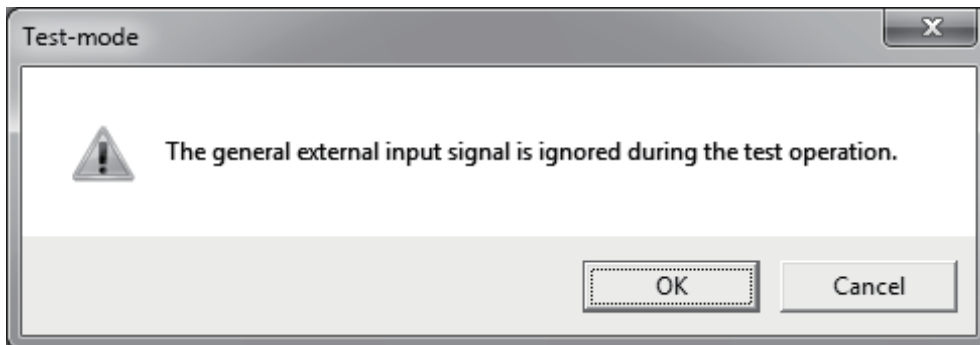

13. POSITIONING MODE

Click the "OK" button to display the setting screen of the single-step feed.

During the servo-on, the following window is displayed to confirm that the operation is in a stop status.

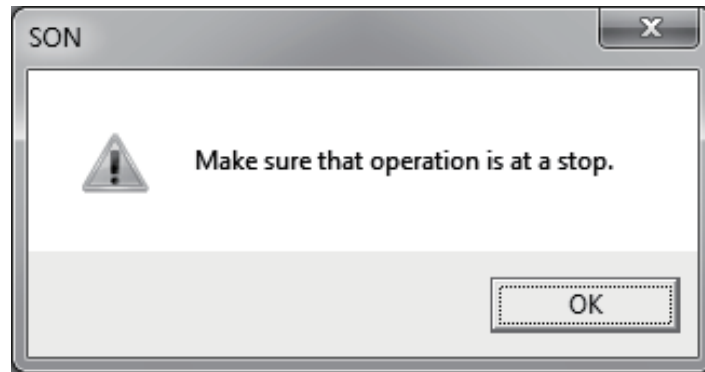

After confirming that the operation is in the stop status, click the "OK" button.

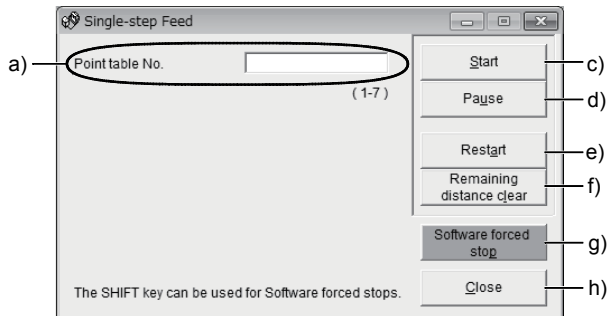

<In point table operation>

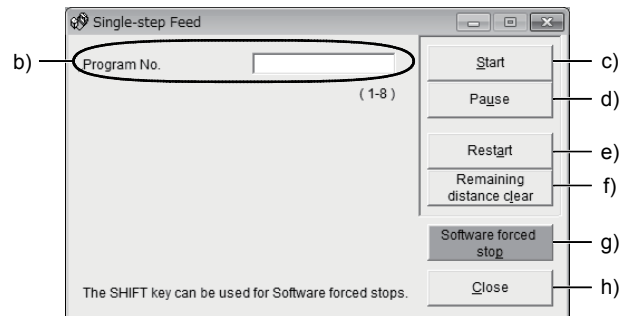

<In program operation>

(a) Point table No. setting (a)

Enter the point table No. into the "Point table No." input field and press the enter key.

(b) Program No. setting (b)

Enter the program No. into the "Program No." input field and press the enter key.

(c) Servo motor start (c)

Click the "Start" button to rotate the servo motor.

(d) Temporary stop of servo motor (d)

Click the "Pause" button to stop the servo motor temporarily.

(e) Servo motor stop (e)

Click the "Pause" button again during a temporary stop of the servo motor to clear the remaining moving distance.

(f) Servo motor restart (f)

Click the "Restart" button during the temporary stop to restart the rotations for the remaining move distance.

(g) Travel distance clear (g)

Click the "Remaining distance clear" during the temporary stop to clear the remaining travel distance.

13. POSITIONING MODE

(h) Servo motor software forced stop (h)

Click the "Software forced stop" button to stop the servo motor rotation immediately. When the "Software forced stop" button is enabled, the "Start" button cannot be used. Click the "Software forced stop" button again to make the "Start" button enabled.

(i) Single-step feed window closing (i)

Click the "Close" button to cancel the single-step feed mode and close the window.

(j) Switching to normal operation mode

To switch from the test operation mode to the normal operation mode, turn OFF the power of the servo amplifier.

APPENDIX

App. 1 Parameter list

POINT
<ul style="list-style-type: none"> ▪ For any parameter whose symbol is preceded by *, set the parameter value and switch power off once, then switch it on again to make that parameter setting valid. ▪ Never change parameters for manufacturer setting.

(1) Position control mode, internal speed control mode, internal torque control mode

Basic setting parameters (PA □□)				Gain/filter parameters (PB □□)			
No.	Symbol	Name	Control mode	No.	Symbol	Name	Control mode
PA01	*STY	Control mode	P, S, T	PB01	FILT	Adaptive tuning mode (Adaptive filter II)	P, S
PA02	*REG	Regenerative option	P, S, T	PB02	VRFT	Vibration suppression control filter tuning mode (Advanced vibration suppression control)	P
PA03		For manufacturer setting		PB03	PST	Position command acceleration/ deceleration time constant (Position smoothing)	P
PA04	*AOP1	Tough drive function selection	P, S	PB04	FFC	Feed forward gain	P
PA05	*FBP	Number of command input pulses per revolution	P	PB05		For manufacturer setting	
PA06	CMX	Electronic gear numerator (Command input pulse multiplying factor numerator)	P	PB06	GD2	Load to motor inertia moment ratio	P, S
PA07	CDV	Electronic gear denominator (Command input pulse multiplying factor denominator)	P	PB07	PG1	Model loop gain	P, S
PA08	ATU	Auto tuning mode	P, S	PB08	PG2	Position loop gain	P
PA09	RSP	Auto tuning response	P, S	PB09	VG2	Speed loop gain	P, S
PA10	INP	In-position range	P	PB10	VIC	Speed integral compensation	P, S
PA11	TLP	Forward torque limit	P, S, T	PB11	VDC	Speed differential compensation	P, S
PA12	TLN	Reverse torque limit	P, S, T	PB12	OVA	Overshoot amount compensation	P
PA13	*PLSS	Command input pulse form	P	PB13	NH1	Machine resonance suppression filter 1	P, S
PA14	*POL	Rotation direction selection	P	PB14	NHQ1	Notch shape selection 1	P, S
PA15	*ENR	Encoder output pulses	P, S, T	PB15	NH2	Machine resonance suppression filter 2	P, S
PA16	*ENR2	Encoder output pulse electronic gear	P, S, T	PB16	NHQ2	Notch shape selection 2	P, S
PA17		For manufacturer setting		PB17		Automatic setting parameter	
PA18				PB18	LPF	Low-pass filter setting	P, S
PA19	*BLK	Parameter writing inhibit	P, S, T	PB19	VRF1	Vibration suppression control vibration frequency setting	P
				PB20	VRF2	Vibration suppression control resonance frequency setting	P
				PB21		For manufacturer setting	
				PB22		For manufacturer setting	
				PB23	VFBF	Low-pass filter selection	P, S
				PB24		For manufacturer setting	
				PB25	*BOP1	Function selection B-1	P
				PB26	*CDP	Gain changing selection	P, S
				PB27	CDL	Gain changing condition	P, S
				PB28	CDT	Gain changing time constant	P, S
				PB29	GD2B	Gain changing load to motor inertia moment ratio	P, S
				PB30	PG2B	Gain changing position loop gain	P
				PB31	VG2B	Gain changing speed loop gain	P, S
				PB32	VICB	Gain changing speed integral compensation	P, S
				PB33	VRF1B	Gain changing vibration suppression control vibration frequency setting	P
				PB34	VRF2B	Gain changing vibration suppression control resonance frequency setting	P
				PB35 to PB37		For manufacturer setting	
				PB38	NH3	Machine resonance suppression filter 3	P, S
				PB39	NHQ3	Notch shape selection 3	P, S
				PB40 to PB50		For manufacturer setting	

APPENDIX

Extension setting parameters (PC □□)			
No.	Symbol	Name	Control mode
PC01	STA	Acceleration time constant	S, T
PC02	STB	Deceleration time constant	S, T
PC03	STC	S-pattern acceleration/deceleration time constant	S, T
PC04	TQC	Torque command time constant	T
PC05	SC0	Internal speed command 0	S
		Internal speed limit 0	T
PC06	SC1	Internal speed command 1	S
		Internal speed limit 1	T
PC07	SC2	Internal speed command 2	S
		Internal speed limit 2	T
PC08	SC3	Internal speed command 3	S
		Internal speed limit 3	T
PC09	MBR	Electromagnetic brake sequence output	P, S, T
PC10	ZSP	Zero speed	P, S, T
PC11	*BPS	Alarm history clear	P, S, T
PC12	TC	Internal torque command	T
PC13	*ENRS	Encoder output pulses selection	P, S, T
PC14	TL2	Internal torque limit 2	P, S, T
PC15	ERZL	Error excessive alarm detection level	P, S, T
PC16		For manufacturer setting	
PC17	*OSL	Overspeed alarm detection level	P, S, T
PC18		For manufacturer setting	
PC19			
PC20			
PC21			
PC22	*COP1	Function selection C-1	P, S, T
PC23	*COP2	Function selection C-2	S
PC24	*COP3	Function selection C-3	S
PC25	*COP4	Function selection C-4	P, S
PC26	ALDT	Detailed setting of overload tough drive	P
PC27	OSCL	Detailed setting of vibration tough drive	P, S
PC28	CVAT	Detailed setting of instantaneous power failure tough drive	P, S
PC29	*COP5	Function selection C-5	P, S, T
PC30	*COP6	Function selection C-6	S
PC31	SC4	Internal speed command 4	S
		Internal speed limit 4	T
PC32	SC5	Internal speed command 5	S
		Internal speed limit 5	T
PC33	SC6	Internal speed command 6	S
		Internal speed limit 6	T
PC34	SC7	Internal speed command 7	S
		Internal speed limit 7	T
PC35 to PC43		For manufacturer setting	
PC44	RECT	Drive recorder alarm specifying	P, S, T
PC45 to PC64		For manufacturer setting	

I/O setting parameters (PD □□)			
No.	Symbol	Name	Control mode
PD01	*DIA1	Input signal automatic ON selection 1	P, S, T
PD02	*DIO	Input signal device selection 0 (CN1-23, CN1-25)	S, T
PD03	*DI1-1	Input signal device selection 1L (CN1-3)	P, S, T
PD04	*DI1-2	Input signal device selection 1H (CN1-3)	P, S, T
PD05	*DI2-1	Input signal device selection 2L (CN1-4)	P, S, T
PD06	*DI2-2	Input signal device selection 2H (CN1-4)	P, S, T
PD07	*DI3-1	Input signal device selection 3L (CN1-5)	P, S, T
PD08	*DI3-2	Input signal device selection 3H (CN1-5)	P, S, T
PD09	*DI4-1	Input signal device selection 4L (CN1-6)	P, S, T
PD10	*DI4-2	Input signal device selection 4H (CN1-6)	P, S, T
PD11	*DI5-1	Input signal device selection 5L (CN1-7)	P, S, T
PD12	*DI5-2	Input signal device selection 5H (CN1-7)	P, S, T
PD13	*DI6-1	Input signal device selection 6L (CN1-8)	P, S, T
PD14	*DI6-2	Input signal device selection 6H (CN1-8)	P, S, T
PD15	*DO1	Output signal device selection 1 (CN1-9)	P, S, T
PD16	*DO2	Output signal device selection 2 (CN1-10)	P, S, T
PD17	*DO3	Output signal device selection 3 (CN1-11)	P, S, T
PD18	*DO4	Output signal device selection 4 (CN1-12)	P, S, T
PD19	*DIF	Input filter setting	P, S, T
PD20	*DOP1	Function selection D-1	P, S, T
PD21		For manufacturer setting	
PD22	*DOP3	Function selection D-3	P
PD23		For manufacturer setting	
PD24	*DOP5	Function selection D-5	P, S, T
PD25		For manufacturer setting	
PD26			

APPENDIX

(2) Positioning mode

Basic setting parameters (PA □□)		
No.	Symbol	Name
PA01	*STY	Control mode
PA02	*REG	Regenerative option
PA03		For manufacturer setting
PA04	*AOP1	Tough drive function selection
PA05	*FBP	Number of virtual pulses per revolution
PA06	*CMX	Electronic gear numerator (Virtual pulse multiplying factor numerator)
PA07	*CDV	Electronic gear denominator (Virtual pulse multiplying factor denominator)
PA08	ATU	Auto tuning mode
PA09	RSP	Auto tuning response
PA10	INP	In-position range
PA11	TLP	Forward torque limit
PA12	TLN	Reverse torque limit
PA13		This parameter is not used.
PA14	*POL	Rotation direction selection
PA15	*ENR	Encoder output pulses
PA16	*ENR2	Encoder output pulse electronic gear
PA17		For manufacturer setting
PA18		
PA19	*BLK	Parameter writing inhibit

Gain/filter parameters (PB □□)		
No.	Symbol	Name
PB01	FILT	Adaptive tuning mode (Adaptive filter II)
PB02	VRFT	Vibration suppression control filter tuning mode (Advanced vibration suppression control)
PB03		This parameter is not used.
PB04	FFC	Feed forward gain
PB05		For manufacturer setting
PB06	GD2	Load to motor inertia moment ratio
PB07	PG1	Model loop gain
PB08	PG2	Position loop gain
PB09	VG2	Speed loop gain
PB10	VIC	Speed integral compensation
PB11	VDC	Speed differential compensation
PB12	OVA	Overshoot amount compensation
PB13	NH1	Machine resonance suppression filter 1
PB14	NHQ1	Notch shape selection 1
PB15	NH2	Machine resonance suppression filter 2
PB16	NHQ2	Notch shape selection 2
PB17		Automatic setting parameter
PB18	LPF	Low-pass filter setting
PB19	VRF1	Vibration suppression control vibration frequency setting
PB20	VRF2	Vibration suppression control resonance frequency setting
PB21		For manufacturer setting
PB22		
PB23	VFBF	Low-pass filter selection
PB24		For manufacturer setting
PB25	*BOP1	Function selection B-1
PB26	*CDP	Gain changing selection
PB27	CDL	Gain changing condition
PB28	CDT	Gain changing time constant
PB29	GD2B	Gain changing load to motor inertia moment ratio
PB30	PG2B	Gain changing position loop gain
PB31	VG2B	Gain changing speed loop gain
PB32	VICB	Gain changing speed integral compensation
PB33	VRF1B	Gain changing vibration suppression control vibration frequency setting
PB34	VRF2B	Gain changing vibration suppression control resonance frequency setting
PB35 to PB37		For manufacturer setting
PB38	NH3	Machine resonance suppression filter 3
PB39	NHQ3	Notch shape selection 3
PB40 to PB50		For manufacturer setting

APPENDIX

Extension setting parameters (PC □□)		
No.	Symbol	Name
PC01		This parameter is not used.
PC02		
PC03	STC	S-pattern acceleration/deceleration time constant
PC04 to PC08		This parameter is not used.
PC09	MBR	Electromagnetic brake sequence output
PC10	ZSP	Zero speed
PC11	*BPS	Alarm history clear
PC12		This parameter is not used.
PC13	*ENRS	Encoder output pulses selection
PC14	TL2	Internal torque limit 2
PC15	ERZL	Error excessive alarm detection level
PC16		For manufacturer setting
PC17	*OSL	Overspeed alarm detection level
PC18 to PC21		For manufacturer setting
PC22	*COP1	Function selection C-1
PC23		This parameter is not used.
PC24	*COP3	Function selection C-3
PC25	*COP4	Function selection C-4
PC26	ALDT	Detailed setting of overload tough drive
PC27	OSCL	Detailed setting of vibration tough drive
PC28	CVAT	Detailed setting of instantaneous power failure tough drive
PC29	*COP5	Function selection C-5
PC30 to PC34		This parameter is not used.
PC35 to PC43		For manufacturer setting
PC44	RECT	Drive recorder alarm designation
PC45 to PC64		For manufacturer setting

I/O setting parameters (PD □□)		
No.	Symbol	Name
PD01	*DIA1	Input signal automatic ON selection 1
PD02	*DI0	Input signal device selection 0 (CN1-23, CN1-25)
PD03	*DI1-1	Input signal device selection 1L (CN1-3)
PD04	*DI1-2	Input signal device selection 1H (CN1-3)
PD05	*DI2-1	Input signal device selection 2L (CN1-4)
PD06	*DI2-2	Input signal device selection 2H (CN1-4)
PD07	*DI3-1	Input signal device selection 3L (CN1-5)
PD08	*DI3-2	Input signal device selection 3H (CN1-5)
PD09	*DI4-1	Input signal device selection 4L (CN1-6)
PD10	*DI4-2	Input signal device selection 4H (CN1-6)
PD11	*DI5-1	Input signal device selection 5L (CN1-7)
PD12	*DI5-2	Input signal device selection 5H (CN1-7)
PD13	*DI6-1	Input signal device selection 6L (CN1-8)
PD14	*DI6-2	Input signal device selection 6H (CN1-8)
PD15	*DO1	Output signal device selection 1 (CN1-9)
PD16	*DO2	Output signal device selection 2 (CN1-10)
PD17	*DO3	Output signal device selection 3 (CN1-11)
PD18	*DO4	Output signal device selection 4 (CN1-12)
PD19	*DIF	Input filter setting
PD20	*DOP1	Function selection D-1
PD21		For manufacturer setting
PD22	*DOP3	Function selection D-3
PD23		For manufacturer setting
PD24	*DOP5	Function selection D-5
PD25 to PD26		For manufacturer setting

APPENDIX

Positioning setting parameters (PE □□)		
No.	Symbol	Name
PE01	*CTY	Command mode selection
PE02	*FTY	Feeding function selection
PE03	*ZTY	Home position return type
PE04	ZRF	Home position return speed
PE05	CRF	Creep speed
PE06	ZST	Home position shift distance
PE07	FTS	Home position return/JOG operation acceleration/deceleration time constant
PE08	*ZPS	Home position return position data
PE09	DCT	Travel distance after proximity dog
PE10	ZTM	Stopper type home position return stopper time
PE11	ZTT	Stopper type home position return torque limit value
PE12	CRP	Rough match output range
PE13	JOG	JOG speed
PE14	OUT1	OUT1 output time selection This parameter is used only for the program method. It is not used in the point table method.
PE15	*BKC	Backlash compensation
PE16	*LMPL	Software limit +
PE17	*LMPH	
PE18	*LMNL	
PE19	*LMNH	Software limit -
PE20	*LPPL	
PE21	*LPPH	
PE22	*LNPL	Position range output address -
PE23	*LNPH	
PE24	*EOP1	Function selection E-1
PE25 to PE28		For manufacturer setting

APPENDIX

App. 2 Servo motor ID codes

Servo motor series ID	Servo motor type ID	Servo motor encoder ID	Servo motor
0F	F053	0049	HF-KN053
	FF13		HF-KN13
	FF23		HF-KN23
	FF43		HF-KN43
16	F053	0044	HF-KP053G1/G5/G7
	FF13		HF-KP13G1/G5/G7
	FF23		HF-KP23G1/G5/G7
	FF43		HF-KP43G1/G5/G7

App. 3 Signal layout recording paper

Position control mode

Internal speed control mode
Internal torque control mode
Positioning mode

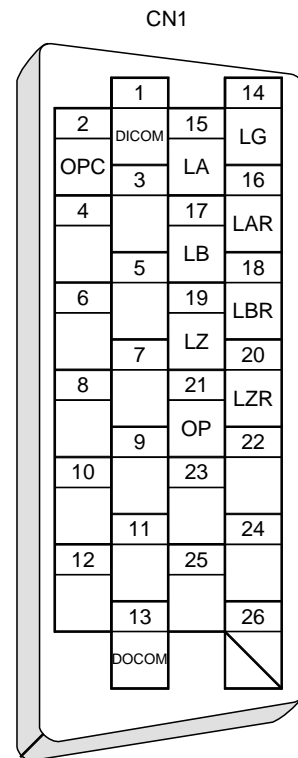
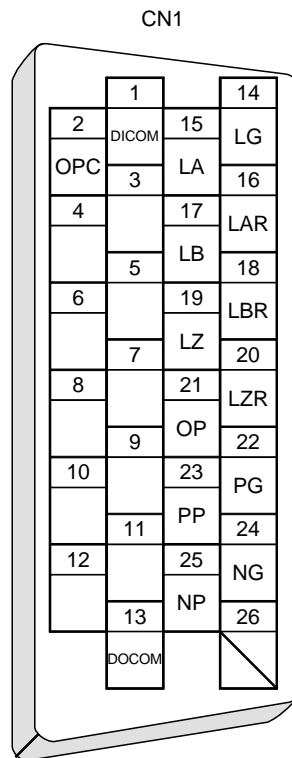

App. 4 Status display block diagram

(1) Position control mode, internal speed control mode, internal torque control mode

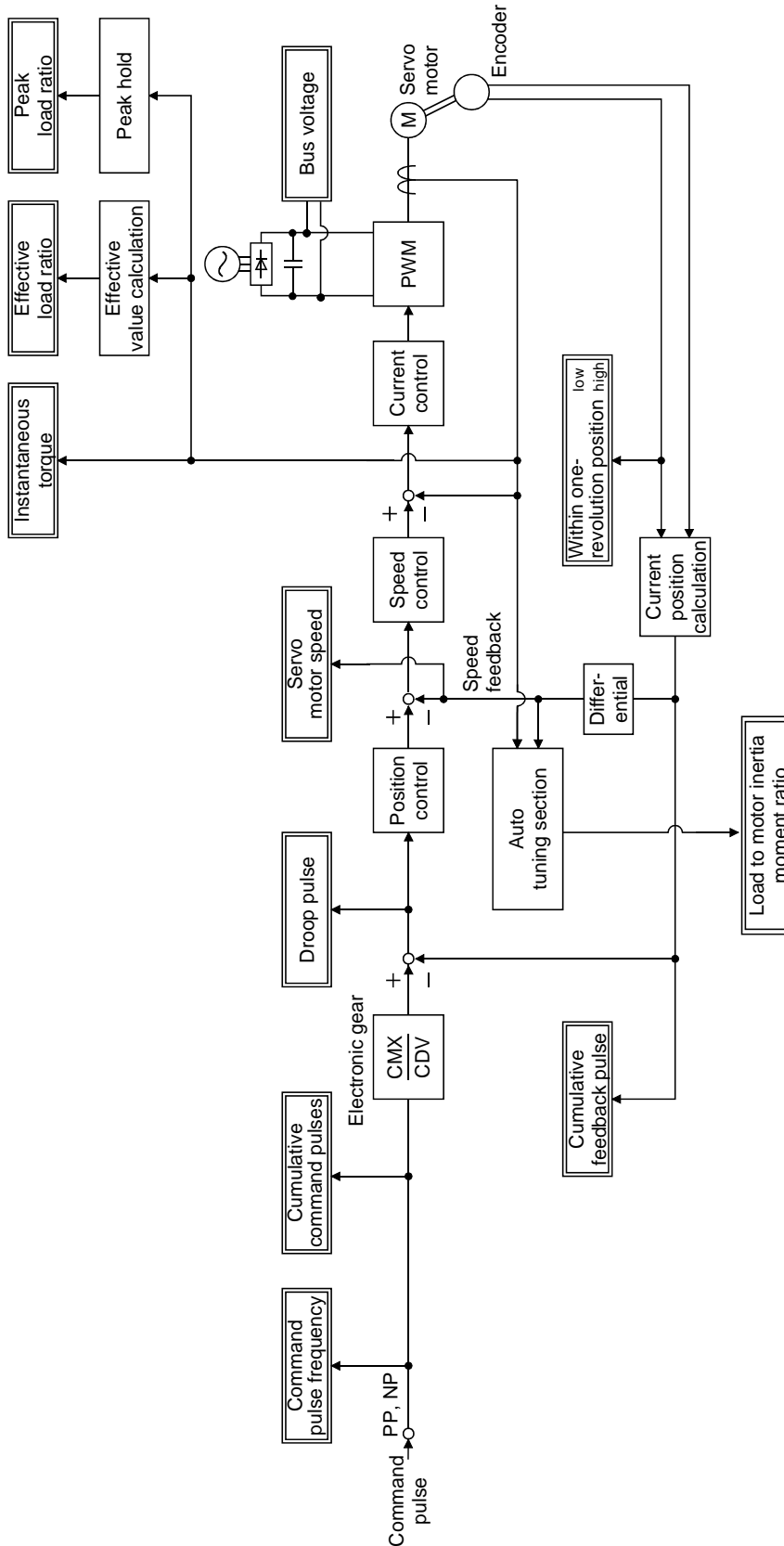

(2) Positioning mode

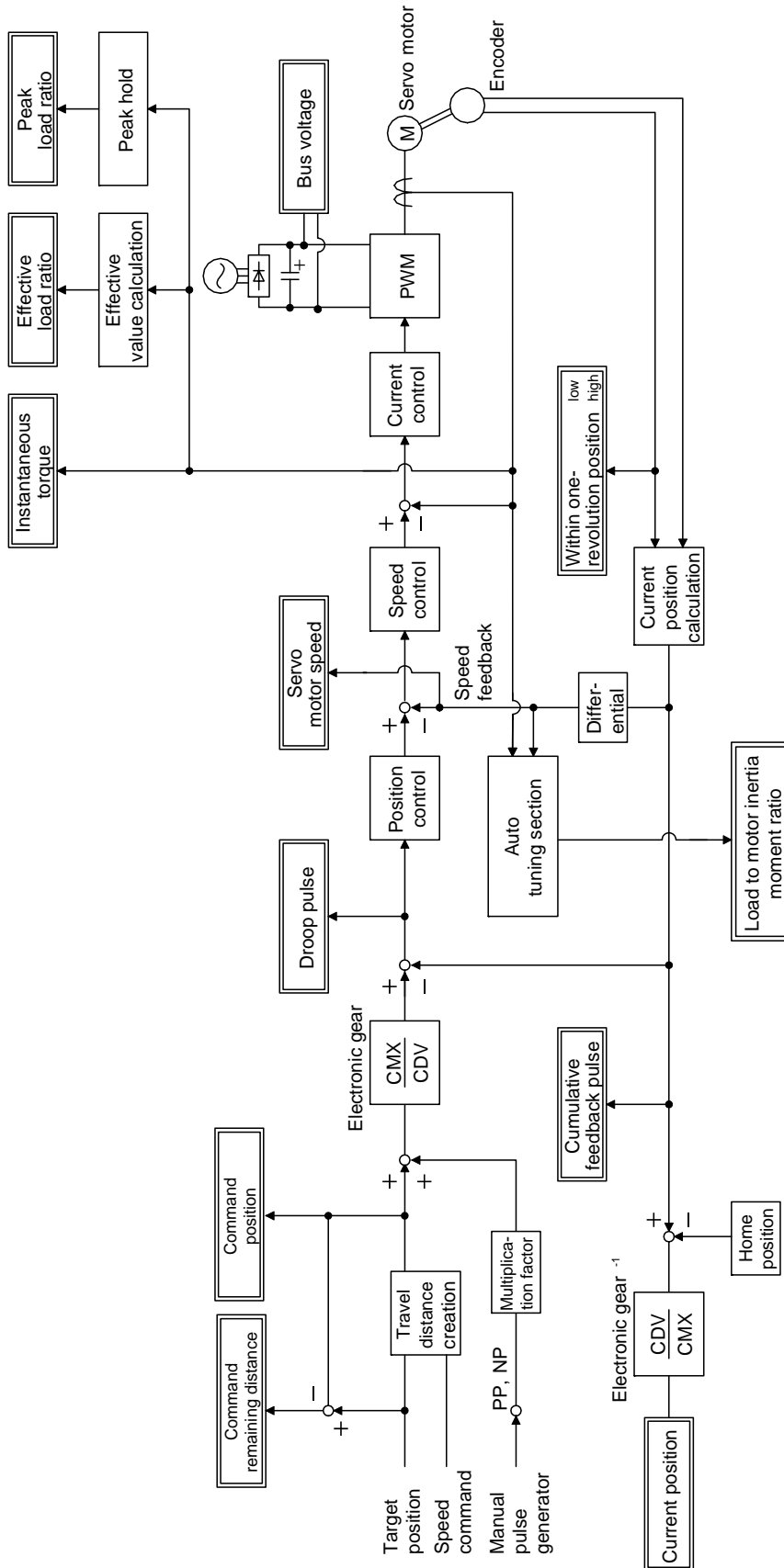

App.5 Compliance with EC directives

App.5.1 What are EC directives?

The EC directives were issued to standardize the regulations of the EU countries and ensure smooth distribution of safety-guaranteed products. In the EU countries, the machinery directive (effective in January, 1995), EMC directive (effective in January, 1996) and low voltage directive (effective in January, 1997) of the EC directives require that products to be sold should meet their fundamental safety requirements and carry the CE marks (CE marking). CE marking applies to machines and equipment into which servo have been installed.

(1) EMC directive

The EMC directive applies also to the servo amplifiers. Hence, they are designed to comply with the EMC directive. Additionally, the EMC directive applies to servo-incorporated machines and equipment. This requires the EMC filters to be used with the servo-incorporated machines and equipment to comply with the EMC directive. For specific EMC directive conforming methods, refer to the EMC Installation Guidelines (IB(NA)67310).

(2) Low voltage directive

The low voltage directive applies also to the servo amplifiers. Hence, they are designed to comply with the low voltage directive.

(3) Machine directive

The servo amplifiers are the main component in a machine configuration.

Do not allow using the machine until the machine in which the servo amplifiers are mounted is declared to comply with the machinery directive.

App.5.2 Precautions for compliance

Be sure to perform an appearance inspection of every unit before installation. In addition, have a final performance inspection on the entire machine/system, and keep the inspection record.

(1) Servo amplifiers and servo motors used

Use the servo amplifiers and servo motors which comply with the standard model.

Servo amplifier	Servo motor	
	HF-KN□	HF-KP□G1/G5/G7
MR-JN-10A(1)	053 * 13	
MR-JN-20A(1)	23	
MR-JN-40A	43	

APPENDIX

(2) Configuration

The control circuit provides safe separation to the main circuit in the servo amplifier.

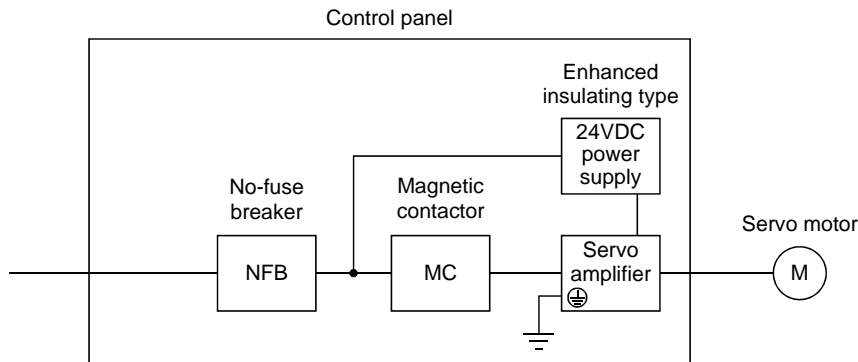

(3) Environment

(a) Operate the servo amplifier at the contamination level 2 or 1 set forth in IEC/EN 61800-5-1. For this purpose, install the servo amplifier in a control box which is protected against water, oil, carbon, dust, dirt, etc. (IP54).

(b) Use the servo motor under the following environmental conditions.

Item		Environmental conditions
(Note 1) Ambient temperature	In operation	(Note 2) 0°C to 55°C (32°F to 131°F)
	Under preservation or under transportation	-20°C to 65°C (-4°F to 149°F)
Ambient humidity	In operation, under preservation or under transportation	90%RH or less
Altitude	In operation or under preservation	1000m or lower
	Under transportation	10000m or lower

Note 1. The ambient temperature here represents the temperature within the control panel.

2. Close mounting of servo amplifiers is possible. In case of mounting servo amplifiers closely, bring the ambient temperature within 0 to 45°C, or use it at 75% or lower effective load ratio.

(4) Power supply

(a) This servo amplifier can be supplied from star-connected supply with earthed neutral point of overvoltage category III set forth in IEC/EN 61800-5-1. However, when using the neutral point of 400V class for single-phase supply, a reinforced insulating transformer is required in the power input section.

(b) When supplying interface power from external, use a 24VDC power supply which has been insulation reinforced in I/O.

(5) Grounding

(a) To prevent an electric shock, always connect the protective earth (PE) terminals (marked ⊕) of the servo amplifier to the protective earth (PE) of the control box.

- (b) Do not connect two ground cables to the same protective earth (PE) terminal. Always connect the cables to the terminals one-to-one.

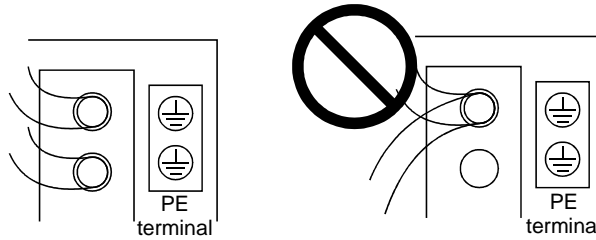

- (c) If a leakage current breaker is used to prevent an electric shock, the protective earth (PE) terminals of the servo amplifier must be connected to the corresponding earth terminals.

(6) Wiring and installation

- (a) When wiring the CNP1 and CNP2 connectors with the twisted wire, strip its sheath and twist its core. At this time, take care to avoid a short caused by the loose wires of the core and the adjacent pole. Do not solder the core as it may cause a contact fault.

- (b) Be sure to install the servo amplifier on a metallic control panel.

(7) Auxiliary equipment and options

- (a) The no-fuse breaker and magnetic contactor used should be the EN or IEC standard-compliant products of the models described in MR-JN-□A SERVO AMPLIFIER INSTRUCTION MANUAL. Use a type B leakage current breaker (RCD). When it is not used, provide insulation between the servo amplifier and other device by double insulation or reinforced insulation, or install a transformer between the main circuit power supply and servo amplifier.

- (b) The sizes of the cables described in MR-JN-□A SERVO AMPLIFIER INSTRUCTION MANUAL meet the following requirements. To meet the other requirements, follow Table 5 and Appendix C in IEC/EN60204-1.

- Ambient temperature: 40(104) [°C(°F)]
- Sheath: PVC (polyvinyl chloride)
- Installed on wall surface or open table tray

- (c) Use the EMC filter for noise reduction.

(8) Performing EMC tests

When EMC tests are run on a machine/device into which the servo amplifier has been installed, it must conform to the electromagnetic compatibility (immunity/emission) standards after it has satisfied the operating environment/electrical equipment specifications.

For the other EMC directive guidelines on the converter unit and servo amplifier (drive unit), refer to the EMC Installation Guidelines (IB(NA)67310).

App.6 Conformance with UL/CSA standard

This servo amplifier is designed to comply with the UL 508C and CSA C22.2 No. 14 standards.

(1) Servo amplifiers and servo motors used

Use the servo amplifiers and servo motors which comply with the standard model.

Servo amplifier	Servo motor	
	HF-KN□	HF-KP□G1/G5/G7
MR-JN-10A(1)	053 * 13	
MR-JN-20A(1)	23	
MR-JN-40A	43	

(2) Installation

MR-JN series products cannot be installed on any other place than within control panels. Design the control panel as follows.

- The volume of the control panel is more than 150% of the total volume of each module.
- The temperature within the control panel is kept at 55°C or lower.

Be sure to install the servo amplifier on a metallic control panel.

(3) Short circuit rating: SCCR (Short Circuit Current Rating)

This servo amplifier conforms to the circuit whose peak current is limited to 100kA or less, 500Volts Maximum. Having been subjected to the short-circuit tests of the UL in the alternating-current circuit, the servo amplifier conforms to the above circuit.

(4) Flanges

Install the servo motor to the flanges, whose sizes are shown below. Otherwise, install the servo motor to flanges providing equivalent or superior heat dissipation effects than the following ones.

Flange size [mm]	Servo motor	
	HF-KN	
250x250x6	053 * 13 * 23	
250x250x12	43	

(5) Capacitor discharge time

The capacitor discharge time is as listed below. To ensure safety, do not touch the charging section for 15 minutes after power-off.

Servo amplifier	Discharge time [min]
MR-JN-10A/20A/40A	2
MR-JN-10A1/20A1	2

APPENDIX

(6) Overload protection characteristics

An electronic thermal relay is built in the servo amplifier to protect the servo motor, servo amplifier and servo motor power lines from overloads. The operation characteristics of the electronic thermal relay are shown below. It is recommended to use the machine which generates unbalanced torque, e.g. a vertical lift application, so that the unbalanced torque is not more than 70% of the rated torque. When you carry out adhesion mounting of the servo amplifier, make circumference temperature into 0 to 45°C or use it with 75% or less of effective load torque.

MR-JN servo amplifier series has solid-state servo motor overload protection. (115% of the servo amplifier rated current is set as standard (full load current).)

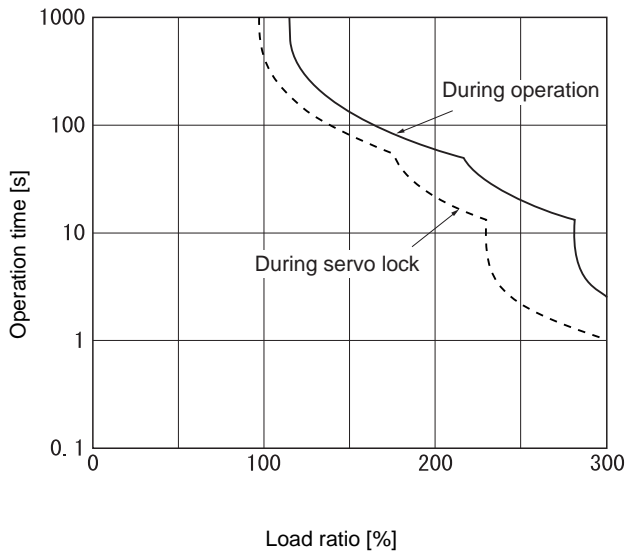

MR-JN-10A(1)

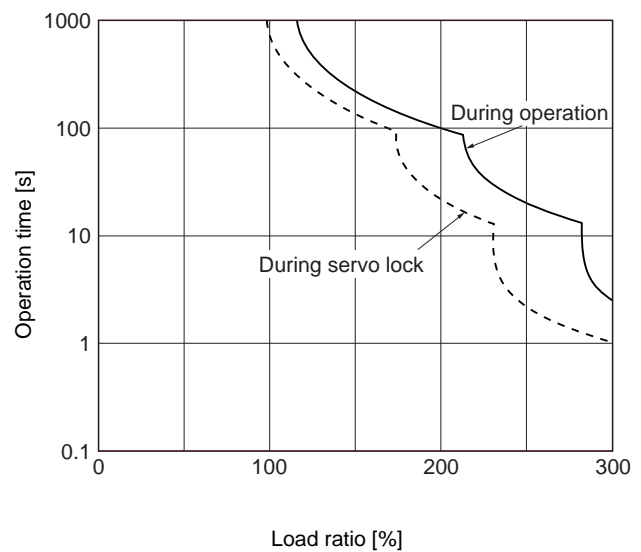

MR-JN-20A(1), MR-JN-40A

(7) Selection example of wires

To comply with the UL/CSA Standard, use UL-approved copper wires rated at 60/75°C for wiring.

The following table shows the wire sizes [AWG] rated at 60°C. The sizes and the symbols rated at 75°C are shown in the brackets.

Servo amplifier	Wire [AWG]				
	L ₁ • L ₂ • ⊕	24V • 0V	U • V • W • ⊕	P • C	B1 • B2
MR-JN-10A(1)/20A(1)/40A	14(14)	14(14)	(Note) 14(14)	14(14)	16(16)

Note. To wire the servo amplifier and a servo motor, use the MR-PWS1CBL (option). To extend the wiring, use the AWG14 wire size.

(8) About wiring protection

For installation in United States, branch circuit protection must be provided, in accordance with the National Electrical Code and any applicable local codes.

For installation in Canada, branch circuit protection must be provided, in accordance with the Canada Electrical Code and any applicable provincial codes.

APPENDIX

(9) Options, peripheral devices

Use the UL/CSA Standard-compliant products.

Use the no-fuse breaker (UL489 Listed MCCB) or a Class T fuse indicated in the table below.

Servo amplifier	No-fuse breaker (Note)		Fuse	
	Current	Voltage AC	Current	Voltage AC
MR-JN-10A	30A frame 5A	240V	10A	300V
MR-JN-20A/10A1	30A frame 10A		15A	
MR-JN-40A/20A1	30A frame 15A		20A	

Note. Listed no-fuse breakers are for when the power factor improving reactor is not used.

(10) Configuration diagram

Representative configuration example to conform to the UL/C-UL standard is shown below. The earth wiring is excluded from the figure configuration.

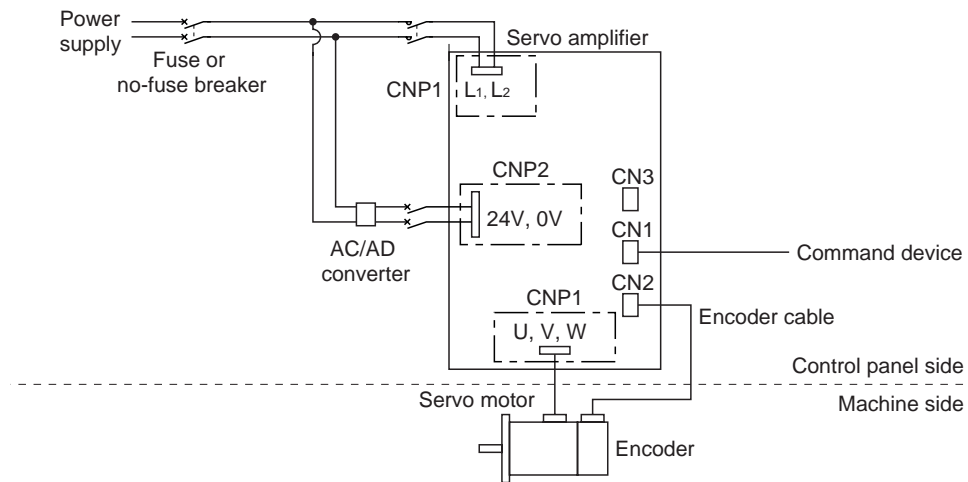

REVISIONS

*The manual number is given on the bottom left of the back cover.

Print Data	*Manual Number	Revision
Sept., 2010	SH(NA)030086-A	First edition
Feb., 2011	SH(NA)030086-B	<p>1-phase 100VAC to 120VAC input is added. Positioning mode is added. "Protective structure" is changed to "IP rating". "Control power supply" is changed to "control circuit power supply". Safety Instructions Partially changed. 2. To prevent fire, note the following Partially added. 4. Additional instructions Partially added and changed. About processing of waste Partially changed. EEPROM life Partially added. About the manuals Partially changed. Introduction Caution is partially changed. Introduction 1.(2) Partially added. Introduction 2. Partially changed. Introduction 2.(1) Diagram is partially changed. Introduction 2.(2)(a)3) Partially changed. Introduction 2.(3) Partially changed. Introduction 2.(4) POINT is partially added. "6" and "7" are added to the set value in the first digit of PA01. PA05 is partially changed. PA13 POINT is partially changed.</p> <p>Introduction 2.(5) Partially changed. Introduction 2.(7) Partially added and changed. Introduction 3.(1) Partially added and changed. Introduction 3.(2) Partially changed. Introduction 4. Caution is added. Partially changed.</p> <p>Section 1.1 Partially added and changed. Section 1.1 (4) The overview of "Positioning mode" is added. Section 1.2 (2) Function block diagram of "Positioning mode (Point table method)" is added. Section 1.2 (3) Function block diagram of "Positioning mode (Program method)" is added. Section 1.3 Contents of MR-JN-10A1/20A1 are added. Output is added. Rated current is added to main circuit power supply. Rated current is added to control circuit power supply. "Input" is changed to "power consumption". Power supply capacity for the interface power supply "200mA" is changed to "0.2A". Items of the positioning mode are added.</p> <p>Section 1.4 Following functions are added. Positioning mode (point table method) Positioning mode (program method) Home position return mode Limit switch Software limit Drive recorder function</p>

Print Data	*Manual Number	Revision	
Feb., 2011	SH(NA)030086-B	<p>Section 1.4</p> <p>Section 1.5 (1)</p> <p>Section 1.5 (2)</p> <p>Section 1.6</p> <p>Section 1.7</p> <p>Section 2.3</p> <p>Section 2.4</p> <p>Chapter 3</p> <p>Section 3.1</p> <p>Section 3.2.1</p> <p>Section 3.2.2</p> <p>Section 3.2.3</p> <p>Section 3.3.1</p> <p>Section 3.3.2 (1)</p> <p>Section 3.3.2 (3)</p> <p>Section 3.3.3 (1)</p> <p>Section 3.3.3 (2) (b) 2)</p> <p>Section 3.3.3 (3) (b)</p> <p>Section 3.4</p> <p>Section 3.4 (1)</p> <p>Section 3.5</p> <p>Section 3.5 (1) (a)</p> <p>Section 3.5 (1) (b)</p> <p>Section 3.5 (2)</p> <p>Section 3.6</p> <p>Section 3.6.1</p> <p>Section 3.6.1 (1) (b) 1)</p> <p>Section 3.6.1 (1) (b) 2)</p> <p>Section 3.6.1 (2)</p> <p>Section 3.6.2 (1) (a)</p> <p>Section 3.6.3 (1)</p> <p>Section 3.7</p>	<p>Contents of the following items are partially added and changed.</p> <ul style="list-style-type: none"> Gain changing function Electronic gear Input signal selection Output signal selection Test operation mode Tough drive function <p>Explanation of serial number is added.</p> <p>Power supply symbol is added.</p> <p>Partially changed.</p> <p>Partially added.</p> <p>Partially changed.</p> <p>Partially changed.</p> <p>Caution is partially changed.</p> <p>Caution is partially added.</p> <p>Diagram is partially changed.</p> <p>Note 1 is partially changed.</p> <p>Note 6 is partially changed.</p> <p>Diagram is all changed.</p> <p>Note 1 is partially changed.</p> <p>Note 2 is partially changed.</p> <p>Diagram is partially changed.</p> <p>Note 1 is partially changed.</p> <p>Note 2 is partially changed.</p> <p>Diagram is partially changed.</p> <p>Note 1 is partially changed.</p> <p>Note 2 is partially changed.</p> <p>Partially changed.</p> <p>Partially changed.</p> <p>Partially changed.</p> <p>Partially changed.</p> <p>Partially changed.</p> <p>POINT is partially added.</p> <p>Partially changed.</p> <p>POINT is partially added.</p> <p>Partially changed.</p> <p>Partially changed.</p> <p>POINT is newly added.</p> <p>POINT is partially added.</p> <p>Note is partially changed.</p> <p>Note is partially changed.</p> <p>Partially changed.</p> <p>POINT is partially changed.</p> <p>Partially changed.</p> <p>Partially changed.</p>

Print Data	*Manual Number	Revision	
Feb., 2011	SH(NA)030086-B	<p>Section 3.8.1</p> <p>Section 3.8.2 (1)</p> <p>Section 3.8.2 (2)</p> <p>Section 3.8.2 (3) (a) 1</p> <p>Section 3.8.2 (3) (b) 1</p> <p>Section 3.8.3 (2)</p> <p>Section 3.10</p> <p>Section 3.10.1</p> <p>Section 3.11.1</p> <p>Section 3.11.2</p> <p>Section 3.11.3 (1) to (5)</p> <p>Section 3.11.4 (1)</p> <p>Section 3.11.4 (2)</p> <p>Chapter 4</p> <p>Section 4.1</p> <p>Section 4.1.1</p> <p>Section 4.1.2</p> <p>Section 4.1.3</p> <p>Section 4.1.5</p> <p>Section 4.1.6</p> <p>Section 4.1.7 (1)</p> <p>Section 4.1.7 (1) (b)</p> <p>Section 4.1.7 (2)</p> <p>Section 4.1.8 (1)</p> <p>Section 4.1.9</p> <p>Section 4.1.11</p> <p>Section 4.1.13</p> <p>Section 4.1.13 (3)</p> <p>Section 4.1.13 (4)</p> <p>Section 4.2.1</p>	<p>Diagram is partially changed.</p> <p>Note 1 is partially changed.</p> <p>Note 2 is partially changed.</p> <p>Note 4 is added.</p> <p>Partially added.</p> <p>Partially added.</p> <p>Note is partially changed.</p> <p>Note is partially changed.</p> <p>Partially changed.</p> <p>Caution is partially changed.</p> <p>Caution is partially changed.</p> <p>Caution is partially changed.</p> <p>Partially changed.</p> <p>Partially changed.</p> <p>Partially changed.</p> <p>Note 3 is partially changed.</p> <p>Note 4 and Note 5 are added.</p> <p>Note 4 is partially changed.</p> <p>Note 5 and Note 6 are added.</p> <p>Caution is partially added and changed.</p> <p>POINT is newly added.</p> <p>Positioning parameters (No. PE □□) is added.</p> <p>POINT is partially added.</p> <p>Partially changed.</p> <p>Reference and writing for positioning parameters (No. PE □□) are added.</p> <p>"00Ch" and "10Eh" are added to setting.</p> <p>"6" and "7" are added to the set value in the first digit.</p> <p>POINT is partially changed.</p> <p>Setting item name of each digit is changed.</p> <p>Note is partially changed.</p> <p>Note is partially changed.</p> <p>Partially changed.</p> <p>Partially changed.</p> <p>Partially added and changed.</p> <p>Unit of each control mode is added as Note.</p> <p>Partially changed.</p> <p>POINT is partially changed.</p> <p>Initial value of PA16 is changed from "1" to "0".</p> <p>Setting range of PA16 is changed from "1 to 65535" to "0 to 65535".</p> <p>Partially changed.</p> <p>Partially changed.</p> <p>Initial values and units of the following parameters are changed.</p> <p>PB06</p> <p>Initial value "70" to "7.0"</p> <p>Unit "× 0.1" to "Multiplier"</p> <p>PB10</p> <p>Initial value "337" to "33.7"</p> <p>Unit "× 0.1ms" to "ms"</p>

Print Data	*Manual Number	Revision	
Feb., 2011	SH(NA)030086-B	Section 4.2.1	PB19 Initial value "1000" to "100.0" Unit " × 0.1Hz" to "Hz" PB20 Initial value "1000" to "100.0" Unit " × 0.1Hz" to "Hz" PB27 Unit is changed to "Refer to section 4.2.2." PB29 Initial value "70" to "7.0" Unit " × 0.1" to "multiplier" PB32 Initial value "337" to "33.7" Unit " × 0.1ms" to "ms" PB33 Initial value "1000" to "100.0" Unit " × 0.1Hz" to "Hz" PB34 Initial value "1000" to "100.0" Unit " × 0.1Hz" to "Hz"
		Section 4.2.2	PB02 Partially changed. PB06 is changed as follows. Initial value "70" to "7.0" Setting range "0 to 3000" to "0.0 to 300.0" Unit " × 0.1" to "multiplier" PB10 is changed as follows. Initial value "337" to "33.7" Setting range "1 to 10000" to "1.0 to 1000.0" Unit " × 0.1ms" to "ms" PB12 The following sentence is added to the end. "Executing one-touch tuning automatically changes this parameter." PB15 The following sentence is added to the end. "Executing one-touch tuning automatically changes this parameter." PB16 The following sentence is added to the end. "Executing one-touch tuning automatically changes this parameter." PB19 is changed as follows. Initial value "1000" to "100.0" Setting range "1 to 1000" to "1.0 to 100.0" Unit " × 0.1Hz" to "Hz" PB20 is changed as follows. Initial value "1000" to "100.0" Setting range "1 to 1000" to "1.0 to 100.0" Unit " × 0.1Hz" to "Hz" PB29 is changed as follows. Initial value "70" to "7.0" Setting range "0 to 3000" to "0.0 to 300.0" Unit " × 0.1" to "multiplier"

Print Data	*Manual Number	Revision	
Feb., 2011	SH(NA)030086-B	Section 4.2.2	<p>PB32 is changed as follows. Initial value "337" to "33.7" Setting range "1 to 50000" to "1.0 to 5000.0" Unit "× 0.1ms" to "ms"</p> <p>PB33 is changed as follows. Initial value "1000" to "100.0" Setting range "1 to 1000" to "1.0 to 100.0" Unit "× 0.1Hz" to "Hz"</p> <p>PB34 is changed as follows. Initial value "1000" to "100.0" Setting range "1 to 1000" to "1.0 to 100.0" Unit "× 0.1Hz" to "Hz"</p>
		Section 4.2.3	Partially changed.
		Section 4.3.1	<p>Initial values and units of the following parameters are changed.</p> <p>PC12 Initial value "0" to "0.0" Unit "× 0.1%" to "%"</p> <p>PC15 Initial value "30" to "3.0" Unit "× 0.1rev" to "rev"</p> <p>PC44 "Drive recorder alarm specifying" is newly added.</p>
		Section 4.3.2	<p>PC11 is partially changed. PC12 is changed as follows. Initial value "0" to "0.0" Setting range "0 to 1000" to "0.0 to 100.0" Unit "× 0.1%" to "%"</p> <p>PC13 "Encoder output pulse cycle setting" is added to the third digit. PC15 is changed as follows. Initial value "30" to "3.0" Setting range "1 to 999" to "0.1 to 99.9" Unit "× 0.1rev" to "rev"</p> <p>PC22 is partially changed. PC25 is partially changed. PC26 is partially changed. PC27 is partially changed. PC28 is partially changed. PC29 is partially changed. PC44 "Drive recorder alarm specifying" is newly added.</p>
		Section 4.3.3	Partially changed.
		Section 4.3.4	"Drive recorder function" is newly added.
		Section 4.4	POINT is partially added.
		Section 4.4.1	PD02 "Input signal device selection 0 (CN1-23, CN1-25)" is newly added.

Print Data	*Manual Number	Revision	
Feb., 2011	SH(NA)030086-B	Section 4.4.2	<p>PD01 0 bit "Automatic/manual selection (MD0)" in the first digit is added.</p> <p>0 bit "Point table No./Program No. selection 1 (DI0)" in the third digit is newly added.</p> <p>1 bit "Point table No./Program No. selection 2 (DI1)" in the third digit is newly added.</p> <p>2 bit "Point table No./Program No. selection 3 (DI2)" in the third digit is newly added.</p> <p>POINT is partially changed.</p> <p>PD02 "Input signal device selection 0 (CN1-23, CN1-25)" is newly added.</p> <p>PD03 Control mode "CP/CL" is added. Note 3 and Note 4 are added.</p> <p>PD04 "Positioning mode" is added to the upper two digits.</p> <p>PD06 "Positioning mode" is added to the upper two digits.</p> <p>PD08 "Positioning mode" is added to the upper two digits.</p> <p>PD10 "Positioning mode" is added to the upper two digits.</p> <p>PD12 "Positioning mode" is added to the upper two digits.</p> <p>PD13 The following sentence is added to the end. "If a value other than the initial value is set, EM1 cannot be used."</p> <p>PD14 "Positioning mode" is added to the upper two digits. The following sentence is added to the end. "If a value other than the initial value is set, EM1 cannot be used."</p> <p>PD15 Control mode "CP/CL" is added. Note 3 and Note 4 are added.</p> <p>PD20 Partially changed.</p>
		Section 4.4.3	Partially changed.
		Chapter 5	POINT is newly added.
		Section 5.1	Partially added and changed.
		Section 5.2	"Point table" and "Positioning setting parameters" are added to the display mode transition.
		Section 5.3	Partially added and changed.
		Section 5.3.1	<p>Following contents are added as a status display for the positioning mode.</p> <ul style="list-style-type: none"> Current position Command position Command remaining distance Point table No./Program No. Step No. <p>Note 1 and Note 2 are added.</p>

Print Data	*Manual Number	Revision	
Feb., 2011	SH(NA)030086-B	Section 5.3.3	Following contents are added as a status display for the positioning mode.
			<ul style="list-style-type: none"> Current position Command position Command remaining distance Point table No./Program No. Step No.
			Note 1 and Note 2 are added.
		Section 5.4	<p>"Drive recorder valid/invalid display" is added.</p> <p>"Single-step feed" is added to the test operation mode.</p>
			Partially added and changed.
		Section 5.5	<p>"The number of drive recorder record times" is added.</p> <p>"Point table error" is added to the parameter errors.</p>
			Partially added and changed.
		Section 5.6	"Point table mode" is newly added.
		Section 5.6.1	"Point table transition" is newly added.
		Section 5.6.2	"Point table mode setting screen sequence" is newly added.
			added.
		Section 5.6.3	"Operation example" of point table is newly added.
		Section 5.6 to 5.10	Changed to section 5.7 to 5.11.
		Section 5.7	POINT is deleted.
		Section 5.7.1	"Positioning setting parameters" is added.
		Section 5.8 (2)	"CN1-23" and "CN1-25" are added to the display definition.
			added.
		Section 5.8 (2) (a)	Control mode "CP/CL" is added.
			Pin No. 23 and 25 are added.
		Section 5.8 (2) (b)	The followings are added.
			Proximity dog (DOG)
			Automatic/manual selection (MD0)
			Temporary stop/restart (TSTP)
			Point table No./Program No. selection 1 (DI0)
			Point table No./Program No. selection 2 (DI1)
			Point table No./Program No. selection 3 (DI2)
			Program input 1 (PI1)
			Home position return completion (ZP)
			Temporary stop (PUS)
			Travel completion (MEND)
			Rough match (CPO)
			Position range output (POT)
			Point table No. output 1 (PT0)
			Point table No. output 2 (PT1)
			Point table No. output 3 (PT2)
			Program output 1 (OUT1)
			SYNC synchronous output (SOUT)
		Section 5.8 (3) (b)	Partially added.
		Section 5.8 (3) (c)	Partially added.
		Section 5.8 (3) (d)	"Positioning mode" is newly added.
		Section 5.9	Partially changed.
		Section 5.10	Caution is partially changed.
			POINT is partially added.
		Section 5.10.1	Partially changed.

Print Data	*Manual Number	Revision	
Feb., 2011	SH(NA)030086-B	Section 5.10.2 (2) Section 5.10.3 (1) (d) Section 5.10.4 (2) Section 5.10.5 Section 5.11 Chapter 6 Section 6.1 Section 6.1.1 Section 6.1.2 Section 6.2 Section 6.3 Section 6.3.1 Section 6.3.2 Section 6.5 Section 7.1 Section 7.1.1 Section 7.1.2 Section 7.1.3 Section 7.2.2 (2) Section 7.2.3 (1) Section 7.2.3 (2) Section 7.2.4 Section 7.2.5 Section 7.3 Section 7.3.2 Section 7.3.3 Section 7.3.4 Section 8.1	Partially changed. Partially changed. Partially changed. Partially changed. Partially changed. POINT is partially added. Partially changed. Partially changed. Partially changed. "(1) Gain adjustment made by the auto tuning mode (parameter No. PA08)" is changed to "(1) One-touch tuning". "(2) One-touch tuning" is changed to "(2) Gain adjustment made by the auto tuning mode (parameter No. PA08)". Title is changed. "Auto tuning" is changed to "Auto tuning mode 1". Title is changed. "Auto tuning mode 1" is changed to "Overview". POINT is partially changed. Title is changed. "Auto tuning mode 1 operation" is changed to "Auto tuning mode 1 basis". Diagram is partially changed. POINT is partially changed. Partially changed. POINT is added. Partially changed. Caution is added. Partially added and changed. Partially changed. Caution is added. Partially changed. Partially changed. Partially changed. Changed to a table format. Partially changed. Partially changed. POINT is added. Partially changed. Partially changed. Partially changed. Title is changed. "Gain changing operation" is changed to "Gain changing procedure". Partially changed. Partially changed. "LED display" is changed to "3-digit, 7-segment LED". Following alarms and warnings are added. A.39 Program error A.61 Operation alarm

Print Data	*Manual Number	Revision	
Feb., 2011	SH(NA)030086-B	Section 8.1	A.90 Home position return incomplete warning
			A.96 Home position setting warning
			A.97 Program operation disabled
			A.98 Software limit warning
			Warning list is partially changed.
		Section 8.2	Partially changed.
			Following alarm contents are added.
			Detailed display 32.1 Overcurrent was detected by the hardware detection circuit (during operation)
			Detailed display 37.3 Point table setting range error
			Detailed display 39.1 Program error
			Detailed display 39.2 Command argument range error
			Detailed display 39.3 Incompatible command
			Detailed display 61.1 Auxiliary function setting error
		Section 8.3	Partially changed.
			Following warning contents are added.
			Detailed display 90.1 Home position return incompleteness
			Detailed display 90.2 Home position return abnormal completion
			Detailed display 96.1 In-position not reached
			Detailed display 96.2 Speed command not converged
			Detailed display 97.1 Program operation disabled
			Detailed display 98.1 Reached the software limit at the forward rotation
			Detailed display 98.2 Reached the software limit at the reverse rotation side
		Section 9.1 (1)	MR-JN-10A1 and MR-JN-20A1 are added.
		Section 9.1 (2)	Partially changed.
		Section 10.1	MR-JN-10A1 and MR-JN-20A1 are added.
			Partially changed.
		Section 10.2	MR-JN-10A1 and MR-JN-20A1 are added.
			Partially changed.
		Section 10.3	POINT is partially changed.
		Section 10.3.1	Partially changed.
		Section 10.3.2	MR-JN-10A1 and MR-JN-20A1 are added.
			Partially changed.
		Section 10.5	Inrush current of MR-JN-10A1/20A1 is added.
		Section 11.1.1	Partially changed.
		Section 11.1.2	Partially changed.
		Section 11.2	MR-JN-10A1 and MR-JN-20A1 are added.
		Section 11.2 (5)	Outline dimension drawings of MR-RB12 and MR-RB032 are changed.
		Section 11.3	Partially changed.
		Section 11.4	POINT is added.
			Partially added and changed.
		Section 11.5 (1)	MR-JN-10A1 and MR-JN-20A1 are added.
		Section 11.5 (2)	Partially changed.
		Section 11.6	Note 2 is partially changed.
		Section 11.7	MR-JN-10A1 and MR-JN-20A1 are added.

Print Data	*Manual Number	Revision	
Feb., 2011	SH(NA)030086-B	Section 11.9 (2) (a)	Partially changed.
		Section 11.9 (2) (d)	Partially changed.
		Section 11.9 (2) (e)	Partially changed.
		Section 11.9 (2) (f)	Partially changed.
		Section 11.10 (1)	MR-JN-10A1 and MR-JN-20A1 are added.
		Table 11.6	
		Section 11.11	MR-JN-10A1 and MR-JN-20A1 are added.
		Section 11.12 (1)	MR-JN-10A1 and MR-JN-20A1 are added.
		Section 11.14	"MR-HDP01 manual pulse generator" is newly added.
		Section 12.1.1	Partially changed.
		Section 12.1.3	Title is changed. "Electromagnetic brake" is changed to "Electromagnetic brake characteristics". Caution is partially changed.
		Section 12.1.3 (1)	Partially added and changed.
		Section 12.1.4	Partially changed.
		Section 12.2	Caution is partially added.
		Section 12.2.2	Partially changed.
		Section 12.2.5	Partially changed.
		Section 12.2.6	Partially changed.
		Section 12.3.2	Partially changed.
		Section 12.5.1	Note is deleted.
		Section 12.5.2 (1)	MR-JN-10A1 and MR-JN-20A1 are added.
		Section 12.5.2 (2)	Torque characteristics for MR-JN-10A1 and MR-JN-20A1 are added.
		Section 12.5.3	Caution is partially changed.
		Section 12.6	Partially changed.
		Section 12.6.1	Note is deleted.
		Section 12.6.2 (1)	MR-JN-10A1 and MR-JN-20A1 are added.
		Section 12.6.2 (2)	Torque characteristics for MR-JN-10A1 and MR-JN-20A1 are added.
		Section 12.6.3	Caution is partially changed.
		Section 12.6.3 (1) (b)	Partially changed.
		Section 12.6.3 (2) (b)	Partially changed.
		Chapter 13	"Positioning mode" is newly added.
		App. 1	POINT is partially added. Parameter list in the positioning mode is added.
		App. 3	Partially changed.
		App. 4	Status display block diagram in the positioning mode is added.
		App. 5	Partially changed.
		App. 6	Partially added and changed.
		App. 7	MR-JN-10A1 and MR-JN-20A1 are added. Partially added and changed.
		App. 8	MR-JN-10A1 and MR-JN-20A1 are added. Partially added and changed.

This manual confers no industrial property rights or any rights of any other kind, nor does it confer any patent licenses. Mitsubishi Electric Corporation cannot be held responsible for any problems involving industrial property rights which may occur as a result of using the contents noted in this manual.

Country/Region	Sales office	Tel/Fax
U.S.A.	Mitsubishi Electric Automation, Inc. 500 Corporate Woods Parkway, Vernon Hills, IL 60061, U.S.A.	Tel : +1-847-478-2100 Fax : +1-847-478-2253
Germany	Mitsubishi Electric Europe B.V. - German Branch Gothaer Strasse 8, D-40880 Ratingen, Germany	Tel : +49-2102-486-0 Fax : +49-2102-486-1120
Taiwan	Setsuyo Enterprise Co., Ltd. 6F No.105 Wu kung 3rd RD, Wu-Ku Hsiang, Taipei Hsien, 248, Taiwan, R.O.C.	Tel : +886-2-2299-2499 Fax : +886-2-2299-2509
Korea	Mitsubishi Electric Automation Korea Co., Ltd. (Service) B1F, 2F, 1480-6, Gayang-Dong, Gangseo-Gu, Seoul, 157-200, Korea	Tel : +82-2-3660-9630 Fax : +82-2-3663-0475
Singapore	Mitsubishi Electric Asia Pte. Ltd. ASEAN Factory Automation Centre 307 Alexandra Road #05-01/02, Mitsubishi Electric Building, Singapore	Tel : +65-6470-2460 Fax : +65-6476-7439
India	Mitsubishi Electric India Pvt. Ltd. India Factory Automation Centre 2nd Floor, DLF Building No.9B, DLF Cyber City Phase III, Gurgaon 122002, Haryana, India	Tel : +91-124-4630300 Fax : +91-124-4630399
Thailand	Mitsubishi Electric Automation (Thailand) Co., Ltd. Bang-Chan Industrial Estate No.111, Soi Serithai 54, T.Kannayao, A.Kannayao, Bangkok 10230, Thailand	Tel : +66-2906-3238 Fax : +66-2906-3239
Australia	Mitsubishi Electric Australia Pty. Ltd. 348 Victoria Road PO BOX11, Rydalmere, N.S.W. 2116 Australia	Tel : +61-2-9684-7777 Fax : +61-2-9684-7245

Warranty

1. Warranty period and coverage

We will repair any failure or defect hereinafter referred to as "failure" in our FA equipment hereinafter referred to as the "Product" arisen during warranty period at no charge due to causes for which we are responsible through the distributor from which you purchased the Product or our service provider. However, we will charge the actual cost of dispatching our engineer for an on-site repair work on request by customer in Japan or overseas countries. We are not responsible for any on-site readjustment and/or trial run that may be required after a defective unit are repaired or replaced.

[Term]

The term of warranty for Product is twelve (12) months after your purchase or delivery of the Product to a place designated by you or eighteen (18) months from the date of manufacture whichever comes first ("Warranty Period"). Warranty period for repaired Product cannot exceed beyond the original warranty period before any repair work.

[Limitations]

- (1) You are requested to conduct an initial failure diagnosis by yourself, as a general rule.
It can also be carried out by us or our service company upon your request and the actual cost will be charged. However, it will not be charged if we are responsible for the cause of the failure.
- (2) This limited warranty applies only when the condition, method, environment, etc. of use are in compliance with the terms and conditions and instructions that are set forth in the instruction manual and user manual for the Product and the caution label affixed to the Product.
- (3) Even during the term of warranty, the repair cost will be charged on you in the following cases:
 - (i) a failure caused by your improper storing or handling, carelessness or negligence, etc., and a failure caused by your hardware or software problem
 - (ii) a failure caused by any alteration, etc. to the Product made on your side without our approval
 - (iii) a failure which may be regarded as avoidable, if your equipment in which the Product is incorporated is equipped with a safety device required by applicable laws and has any function or structure considered to be indispensable according to a common sense in the industry
 - (iv) a failure which may be regarded as avoidable if consumable parts designated in the instruction manual, etc. are duly maintained and replaced
 - (v) any replacement of consumable parts (battery, fan, smoothing capacitor, etc.)
 - (vi) a failure caused by external factors such as inevitable accidents, including without limitation fire and abnormal fluctuation of voltage, and acts of God, including without limitation earthquake, lightning and natural disasters
 - (vii) a failure generated by an unforeseeable cause with a scientific technology that was not available at the time of the shipment of the Product from our company
 - (viii) any other failures which we are not responsible for or which you acknowledge we are not responsible for

2. Term of warranty after the stop of production

- (1) We may accept the repair at charge for another seven (7) years after the production of the product is discontinued. The announcement of the stop of production for each model can be seen in our Sales and Service, etc.
- (2) Please note that the Product (including its spare parts) cannot be ordered after its stop of production.

3. Service in overseas countries

Our regional FA Center in overseas countries will accept the repair work of the Product. However, the terms and conditions of the repair work may differ depending on each FA Center. Please ask your local FA center for details.

4. Exclusion of responsibility for compensation against loss of opportunity, secondary loss, etc.

Whether under or after the term of warranty, we assume no responsibility for any damages arisen from causes for which we are not responsible, any losses of opportunity and/or profit incurred by you due to a failure of the Product, any damages, secondary damages or compensation for accidents arisen under a specific circumstance that are foreseen or unforeseen by our company, any damages to products other than the Product, and also compensation for any replacement work, readjustment, start-up test run of local machines and the Product and any other operations conducted by you.

5. Change of Product specifications

Specifications listed in our catalogs, manuals or technical documents may be changed without notice.

6. Application and use of the Product

- (1) For the use of our General-Purpose AC Servo, its applications should be those that may not result in a serious damage even if any failure or malfunction occurs in General-Purpose AC Servo, and a backup or fail-safe function should operate on an external system to General-Purpose AC Servo when any failure or malfunction occurs.
- (2) Our General-Purpose AC Servo is designed and manufactured as a general purpose product for use at general industries. Therefore, applications substantially influential on the public interest for such as atomic power plants and other power plants of electric power companies, and also which require a special quality assurance system, including applications for railway companies and government or public offices are not recommended, and we assume no responsibility for any failure caused by these applications when used.
In addition, applications which may be substantially influential to human lives or properties for such as airlines, medical treatments, railway service, incineration and fuel systems, man-operated material handling equipment, entertainment machines, safety machines, etc. are not recommended, and we assume no responsibility for any failure caused by these applications when used.
We will review the acceptability of the abovementioned applications, if you agree not to require a specific quality for a specific application. Please contact us for consultation.

MODEL	
MODEL CODE	



HEAD OFFICE : TOKYO BLDG MARUNOUCHI TOKYO 100-8310