

MELSEC QnA Series

Programmable Controller

Guidebook

QnACPU

REVISIONS

*The manual number is given on the bottom left of the back cover.

Print Date	*Manual Number	Revision
Jul., 1996	IB (NA) 66606-A	First edition

SAFETY CAUTIONS

(You must read these cautions before using the product)

In connection with the use of this product, in addition to carefully reading both this manual and the related manuals indicated in this manual, it is also essential to pay due attention to safety and handle the product correctly.

The safety cautions given here apply to this product in isolation. For information on the safety of the PC system as a whole, refer to the CPU module User's Manual.

These **SAFETY CAUTIONS** are classified into two grades: "DANGER" and "CAUTION".



DANGER

Safety caution given when incorrect handling could result in hazardous situations involving the possibility of death or serious injury.



CAUTION

Safety caution given when incorrect handling could result in hazardous situations involving the possibility of moderate or light injury or damage to property.

Note that, depending on the circumstances, failing to follow a  **CAUTION** may also have very serious consequences.

Both of these classes of safety caution are very important and must be observed.

Store this manual carefully in a place where it is accessible for reference whenever necessary, and forward a copy of the manual to the end user.

[System Design Precautions]



- Safety circuits should be installed external to the programmable controller to ensure that the system as a whole will continue to operate safely in the event of an external power supply malfunction or a programmable controller failure. Erroneous outputs and operation could result in an accident.
 - 1) The following circuitry should be installed outside the programmable controller:

Interlock circuitry for the emergency stop circuit protective circuit, and for reciprocal operations such as forward/reverse, etc., and interlock circuitry for upper/lower positioning limits, etc., to prevent machine damage.
 - 2) When the programmable controller detects an abnormal condition, processing is stopped and all outputs are switched OFF. This happens in the following cases:
 - When the power supply module's over-current or over-voltage protection device is activated.
 - When an error (watchdog timer error, etc.) is detected at the PC CPU by the self-diagnosis function.Some errors, such as input/output control errors, cannot be detected by the PC CPU, and there may be cases when all outputs are turned ON when such errors occur. In order to ensure that the machine operates safely in such cases, a failsafe circuit or mechanism should be provided outside the programmable controller. Refer to the CPU module user's manual for an example of such a failsafe circuit.
 - 3) Outputs may become stuck at ON or OFF due to an output module relay or transistor failure. An external circuit should therefore be provided to monitor output signals whose incorrect operation could cause serious accidents.
- A circuit should be installed which permits the external power supply to be switched ON only after the programmable controller power has been switched ON. Accidents caused by erroneous outputs and motion could result if the external power supply is switched ON first.
- When a data link communication error occurs, the status shown below will be established at the faulty station. In order to ensure that the system operates safely at such times, an interlock circuit should be provided in the sequence program (using the communication status information).

Erroneous outputs and operation could result in an accident.

 - 1) The data link data which existed prior to the error will be held.
 - 2) All outputs will be switched OFF at MELSECNET (II, /B, /10) remote I/O stations.
 - 3) At the MELSECNET/MINI-S3 remote I/O stations, all outputs will be switched OFF or output statuses will be held, depending on the E.C. mode setting.For details on procedures for checking faulty stations, and for operation statuses when such errors occur, refer to the appropriate data link manual.

[System Design Precautions]

 CAUTION

- Do not bundle control lines or communication wires together with main circuit or power lines, or lay them close to these lines.
As a guide, separate the lines by a distance of at least 100 mm, otherwise malfunctions may occur due to noise.
When file register R that are outside the range are read, e.g. by a MOV instruction, the file register data will become FFFF_H and use of this data will cause malfunctions. Take care not to use file registers that are outside the range when designing programs.
For details on instructions, refer to the Programming Manual.

[Cautions on Mounting]

 CAUTION

- Use the PC in an environment that conforms to the general specifications in the manual.
Using the PC in environments outside the ranges stated in the general specifications will cause electric shock, fire, malfunction, or damage to/deterioration of the product.
- Make sure that the module fixing projection on the base of the module is properly engaged in the module fixing hole in the base unit before mounting the module.
Failure to mount the module properly will result in malfunction or failure, or in the module falling.
- Extension cables should be securely connected to base unit and module connectors. Check for loose connection after installation.
A poor connection could result in contact problems and erroneous inputs/outputs.
- Plug the memory card firmly into the memory card mounting connector. Check for loose connection after installation.
A poor connection could result in erroneous operation.

[Cautions on Wiring]

 **DANGER**

- Switch off the external power supply before starting installation and wiring work.
Failure to do so could result in electrical shocks and equipment damage.
- After installation and wiring is completed, be sure to attach the terminal cover before switching the power ON and starting operation.
Failure to do so could result in electrical shocks.

 **CAUTION**

- Be sure to ground the FG and LG terminals, carrying out at least class 3 grounding work with a ground exclusive to the PC.
Otherwise there will be a danger of electric shock and malfunctions.
- Carry out wiring to the PC correctly, checking the rated voltage and terminal arrangement of the product.
Using a power supply that does not conform to the rated voltage, or carrying out wiring incorrectly, will cause fire or failure.
- Outputs from multiple power supply modules should not be connected in parallel. Failure to do so could cause the power supply module to overheat, resulting in a fire or module failure.
- Tighten the terminal screws to the stipulated torque.
Loose screws will cause short circuits, fire, or malfunctions.
- Make sure that no foreign matter such as chips or wiring offcuts gets inside the module.
It will cause fire, failure or malfunction.
- Connectors for external connections should be crimped, pressure welded, or soldered in the correct manner using the correct tools.
For details regarding crimping and pressure welding tools, refer to the input/output module user's manual.
A poor connection could cause shorts, fire, and erroneous operation.

[Cautions on Startup and Maintenance]



DANGER

- Do not touch terminals while the power is ON.
This will cause malfunctions.
- Make sure that the battery is connected properly. Do not attempt to charge or disassemble the battery, do not heat the battery or place it in a flame, and do not short or solder the battery.
Incorrect handling of the battery can cause battery heat generation and ruptures which could result in fire or injury.
- Switch the power off before cleaning or re-tightening terminal screws.
Carrying out this work while the power is ON will cause failure or malfunction of the module.



CAUTION

- In order to ensure safe operation, read the manual carefully to acquaint yourself with procedures for program changes, forced outputs, RUN, STOP, and PAUSE operations, etc., while operation is in progress.
Incorrect operation could result in machine failure and injury.
- Do not disassemble or modify any module.
This will cause failure, malfunction, injuries, or fire.
- Switch the power OFF before mounting or removing the module.
Mounting or removing it with the power ON can cause failure or malfunction of the module.
- When replacing fuses, be sure to use the prescribed fuse. A fuse of the wrong capacity could cause a fire.

[Cautions on Disposal]



CAUTION

- Dispose of this product as industrial waste.

INTRODUCTION

Thank you for choosing the Mitsubishi MELSEC-QnA Series of General Purpose Programmable Controllers. Please read this manual carefully so that the equipment is used to its optimum. A copy of this manual should be forwarded to the end User.

CONTENTS

1. USING THIS MANUAL	1-1 ~ 1-3
1.1 Terms and Abbreviations Used in This Manual	1-2
1.2 Basic Key Specifications	1-3
2. QnACPU GENERAL DESCRIPTION	2-1 ~ 2-6
2.1 General Description	2-1
3. OPERATING PROCEDURE USING THE QnACPU	3-1 ~ 3-59
3.1 Applicable System Configuration	3-1
3.2 General Procedure for Overall Operation	3-2
3.3 Starting Up GPP Functions after Completing Peripheral Device Preparations	3-3
3.3.1 Preparing the IBM PC/AT hardware	3-3
3.3.2 Installing the GPP function software package	3-5
3.3.3 Starting the GPP functions	3-9
3.3.4 Corrective action when an error occurs	3-10
3.4 Creating Programs	3-11
3.4.1 Selecting CPU type used and setting file	3-11
3.4.2 Programming in ladder mode	3-13
3.4.3 Appending comments to devices	3-18
3.4.4 Saving program to hard disk	3-20
3.4.5 Convenient functions for programming	3-22
3.5 Operating the CPU for Monitoring and Testing	3-29
3.5.1 Preparations for operating the CPU	3-29
3.5.2 Writing program to CPU	3-38
3.5.3 Operating the CPU for monitoring	3-40
3.5.4 Modifying program while monitoring CPU operation (online program change (write during RUN))	3-44
3.5.5 Registering a password	3-46
3.5.6 Checking responses to forced faults (PC diagnosis)	3-49
3.6 Printing the Program	3-54
3.6.1 Setting the printer and paper size	3-54
3.6.2 Printing out the ladder program	3-56
3.6.3 Sample ladder program print-out	3-58
3.7 Quitting GPP Functions	3-59
4. MAKING THE MOST OF YOUR QnACPU (1)	4-1 ~ 4-76
4.1 System Configuration	4-1
4.2 Programming for Individual Control Processes	4-2
4.2.1 File structure	4-2
4.2.2 Sample program	4-4
4.2.3 Program list monitor	4-9
4.3 Easy Programming	4-14

4.3.1	Direct access of special-function module buffer memory as devices	4 – 14
4.3.2	Accessing word devices as bit units and using differential contacts.	4 – 15
4.4	Convenient Functions When Using QnACPU	4 – 16
4.4.1	Allocation of optimal device points range for the system used	4 – 16
4.4.2	Setting device values required by the system as initial values	4 – 19
4.4.3	Boot operation with a program transferred from memory card to QnACPU internal memory	4 – 28
4.4.4	Remote operation of the QnACPU from a distant location	4 – 35
4.4.5	What are local devices?	4 – 52
4.5	Easy Program Debugging	4 – 56
4.5.1	Simultaneous monitoring by multiple operators	4 – 56
4.5.2	Monitoring devices at any step	4 – 58
4.6	Programming	4 – 62
4.6.1	Creating one program	4 – 62
4.6.2	Creating multiple programs	4 – 67
5.	MAKING THE MOST OF YOUR QnACPU (2)	5 – 1 ~ 5 – 28
5.1	Programming Before I/O Module Configuration is Determined	5 – 1
5.1.1	Programming using labels	5 – 1
5.2	Utilizing Program Resources	5 – 16
5.2.1	Program standardization with user-created macros	5 – 16

About Manuals

The manuals related to the QnACPU are listed in the table below.
Please order those you require.

Related Manuals

Manual Name	Manual Number
Q2A(S1)/Q3A/Q4ACPU User's Manual Describes the performance, functions, and handling of the Q2ACPU(S1), Q3ACPU, and Q4ACPU, and the specifications and handling of memory cards and base units.	IB-66608
QnACPU Programming Manual (Fundamentals) Describes how to create programs, the names of devices, parameters, and types of program. (Purchased separately)	IB-66614
QnACPU Programming Manual (Common Instructions) Describes how to use sequence instructions, basic instructions, and application instructions. (Purchased separately)	IB-66615
QnACPU Programming Manual (Special Function) Describes the dedicated instructions for special function modules available when using the Q2ACPU(S1), Q3ACPU, and Q4ACPU. (Purchased separately)	IB-66616
QnACPU Programming Manual (AD57 Instructions) Describes the dedicated instructions for controlling an AD57(S1) type CRT controller module available when using the Q2ACPU(S1), Q3ACPU, or Q4ACPU. (Purchased separately)	IB-66617
QnACPU Programming Manual (PID Control Instructions) Describes the dedicated instructions for PID control available when using the Q2ACPU(S1), Q3ACPU, or Q4ACPU. (Purchased separately)	IB-66618
Type SW0IVD-GPPQ GPP Function Operating Manual (Offline)	IB-66623
Type SW0IVD-GPPQ GPP Function Operating Manual (Online)	IB-66624

1. USING THIS MANUAL

This manual explains:

- What type of CPU the Q2ACPU(S1), Q3ACPU, and Q4ACPU are;
- The operating procedures when using QnA;
- And examples of use of the QnA features.

It includes descriptions of the operations of the SW□IVD-GPPQ GPP function software package (hereafter abbreviated to "GPPQ").

See the manuals listed in the table of related manuals for more details about information and operations described in this manual. Refer to the related manuals for a deeper understanding of the QnACPU functions and GPPQ functions.

The structure of this manual is as follows:

Chapter 1 USING THIS MANUAL

Describes the terms and abbreviations used in this manual and the basic key operations.

Chapter 2 QnACPU GENERAL DESCRIPTION

Describes the structured files which are a feature of QnACPU and provides a simple explanation of structured programs in multiple files.

Chapter 3 OPERATING PROCEDURE USING THE QnACPU

Describes the QnACPU operation flow using an example system configuration and describes the GPPQ operations for programming.

The operations described include installing the software in the peripheral device, programming, CPU operation, and printing out.

Chapter 4 MAKING THE MOST OF YOUR QnACPU (1)

Gives tips on programming with multiple files, which is a feature of QnACPU.

Chapter 5 MAKING THE MOST OF YOUR QnACPU (2)

Describes programming with labels, which is a feature of QnACPU.

Also describes how to use macro instructions.

1.1 Terms and Abbreviations Used in This Manual

The following abbreviations are used in this manual.

- (1) QnACPU An abbreviation for a Q2ACPU, Q2ACPU-S1, Q3ACPU, or Q4ACPU CPU module.
- (2) GPPQ (GPP function software) Abbreviation for the SW□IVD-GPPQ GPP function software package.
- (3) IBM PC/AT An IBM PC/AT computer, or 100% compatible (*1).
- (4) Peripheral device capable of GPP functions ... General term for an IBM PC/AT, or other peripheral device, which operates the GPP function software.
- (5) Internal memory QnACPU internal RAM for storing sequence programs, etc.
- (6) Memory card Abbreviation for a Q1MEM-□□□ memory card.
- (7) ACPU General term for MELSEC-A Series PC CPUs.

*1 IBM is a registered trademark of International Business Machines Corporation.

POINT

The RAM memory built into the QnACPU is referred to as "internal memory" in this manual.
The term "internal RAM" appearing in SW□IVD-GPPQ displays also refers to this internal memory.

1.2 Basic Key Specifications

The key applications with the GPP functions are listed in the table below.

(1) Key Applications

Key Name	Application	Key Name	Application
[Esc]	Closing windows, halting execution, selecting an instruction Opening/closing windows	[F11]	Opens the mode select window
[Tab]	Tab code input, rapid cursor movement	[↑][↓][←][→]	Moves the cursor or scrolls through lines of a ladder or list display ([↑][↓])
[Ctrl] + [Tab]			
[Ctrl]	Used in combination with alphanumeric keys and functions keys	[Back Space]	Deletes the character to the left of the cursor
[Shift]	Selects the character at the Shift position	[Enter]	Inputs the carriage return
[Caps Lock]	Switches between uppercase and lowercase characters	[Ctrl] + [Home]	Moves the cursor to step 0 in the ladder or list mode
[Alt]	Selects the menu	[Ctrl] + [End]	Moves the cursor to the END instruction in the ladder or list mode
[Page Up]	Scrolls page up (- direction) one screen for ladder, list, or help display	[Print Screen]	Copies the screen
[Page Down]	Scrolls page down (+ direction) one screen for ladder, list, or help display	[Scroll Lock]	Disables scrolling up or down
[Insert]	Inserts a space at the cursor position	[Num Lock]	Sets the numeric keypad for numeric input only
[Delete]	Deletes the character at the cursor position (clears entire set contents)	[F12]	Opens the HELP window
[Home]	Moves the cursor to the home position		

2. QnACPU GENERAL DESCRIPTION

2.1 General Description

The QnACPU is a PC CPU which is both easier to use and more sophisticated than the previous ACPUs. In particular, programming efficiency is enhanced by structured programs and instruction definition with macro instructions. QnACPU offers the following features:

- High-speed Processing

- (1) Increased processing speed for both basic and application instructions realizes a further dramatic jump in operation speed (approximately 3-times increase for PCMIX value * ratio using Mitsubishi AnU). This realizes dramatic reductions in tact time and allows high-speed processing of complex data.

	A4UCPU	Q4ACPU
Basic instructions	0.15 μ s	→ 0.075 μ s (2 x)
Transfer instructions	0.90 μ s	→ 0.225 μ s (4 x)

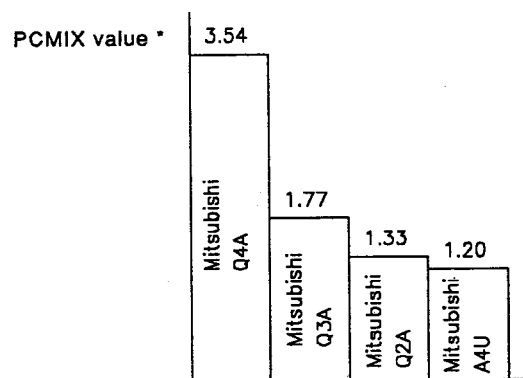

* PCMIX value: The average number of instructions executed in 1 μ s.

High Memory Capacity

Serial execution of 124 k steps maximum in internal memory (4-times increase)

Maximum memory card capacity: 2 MB x 2 (4-times increase)

- (2) The highly integrated IC memory card allows large volumes of data to be managed (2 MB x 2 max.).

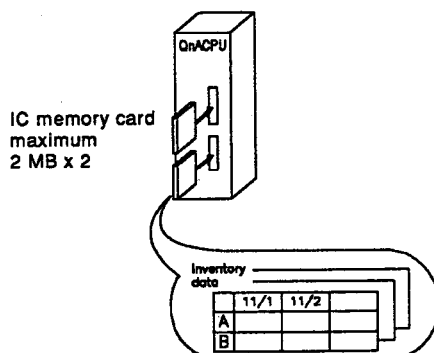

- 1) The application of highly integrated IC memory cards has significantly increased the capacity of the expansion data memory (approximately 5-times increase using Mitsubishi AnUCPU). This makes it easier to handle large volumes of data.

- 2) The cards can also be used to save multiple programs and store comments.

- Program Management

Decentralized control of programs and data is possible with a maximum of 128 files.

This promotes structured programming and allows debugging and program maintenance by multiple programmers.

(1) Multiple program management

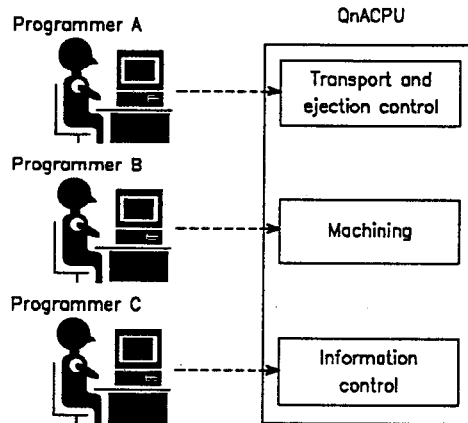

A program can be stored in the CPU as multiple smaller programs.

Dividing the program by programmer, by function, or by process, allows multiple programmers to simultaneously develop a program and simplifies re-using the program.

When a program is modified, only the relevant file needs to be changed, which means that unwanted effects on other parts of the program can be minimized.

To simplify program maintenance, a comment and time-stamp is appended to each modification.

- Structured Programs

Programs can be selected from four types: initial execution, scan execution, low-speed execution, and standby.

These programs can be set to run when required, thereby reducing the scan time of the permanently executing scan program.

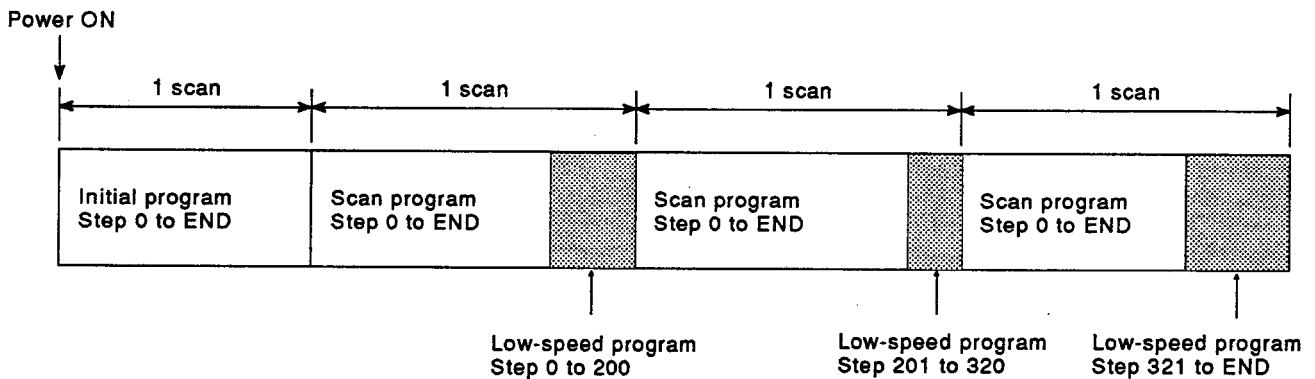

Program Standardization

(1) Macro instructions

This function allows user-created instructions to be created by combining sequence instructions.

Using macro instructions allows the device numbers to be easily changed to match the system used, as shown below.

(a) Saved macro

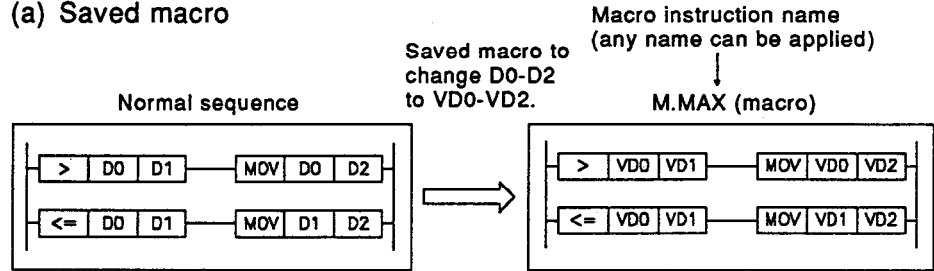

(b) Macro utilization

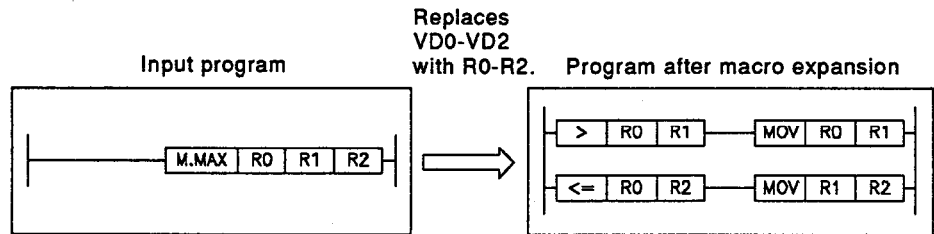

(2) Programming with labels (program standardization)

If the CPU type is set to "Xtype", standard programs can be created using labels, without considering the CPU model name, I/O addresses, or device number allocation. These standardized programs can be used by allocating devices to the labels to match the system used.

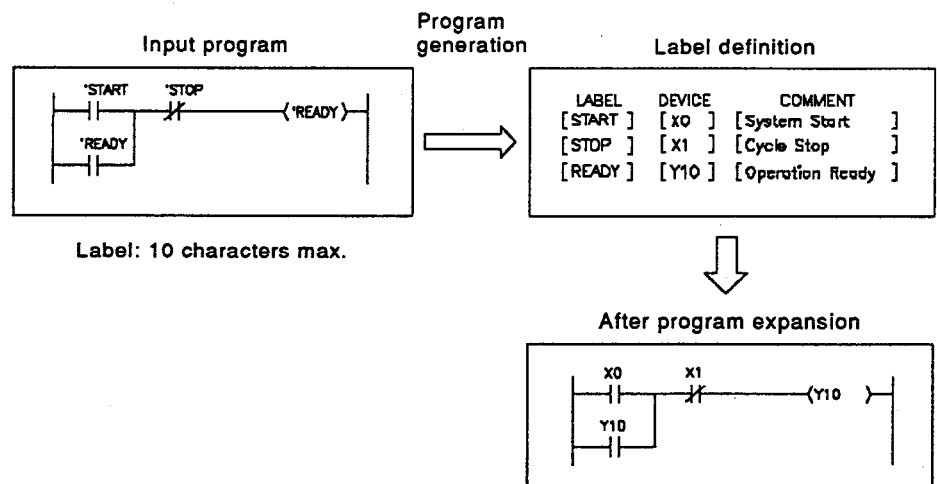

- Reduced Programming Time and Effective Memory Utilization

A number of convenient instructions are provided to reduce programming time. The number of device points can be allocated to match the system, such that each required device occupies only the required number of points, and unnecessary devices can be removed from the 28 k words of device memory.

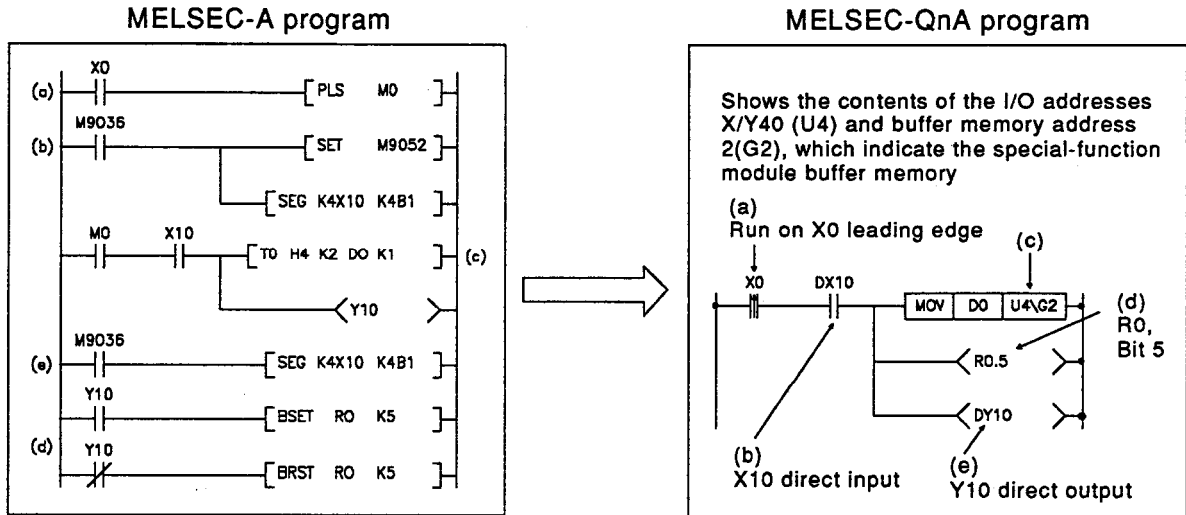

- Flexible Operation

(1) Comprehensive editing functions

- (a) Simultaneous, parallel editing of four programs.
- (b) One-touch switching of the edited program.
- (c) Cutting and pasting between edited programs.
- (d) Special features, such as vertical and horizontal line connections and parallel coil insertion, for easy creation of ladder programs.

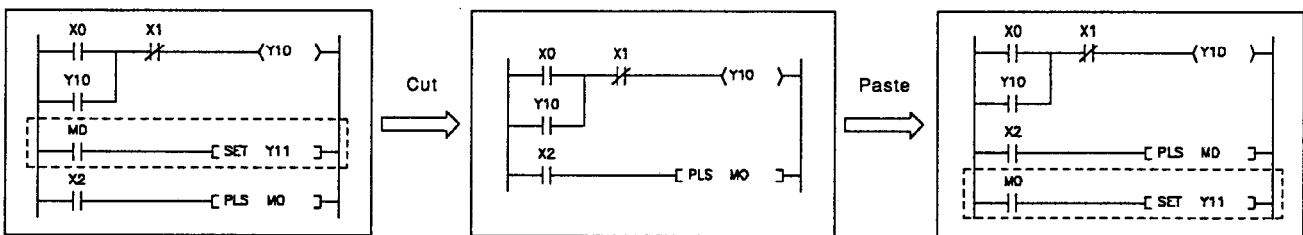

(2) Transparent operation

- (a) The pull-down menus and dialog boxes offer ease of operation equivalent to commercial software packages. Frequently used functions can be allocated to function keys to ensure correct operation every time.

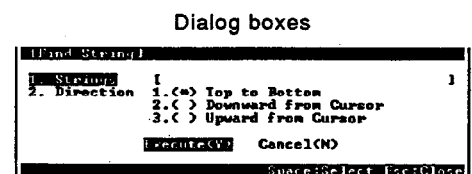
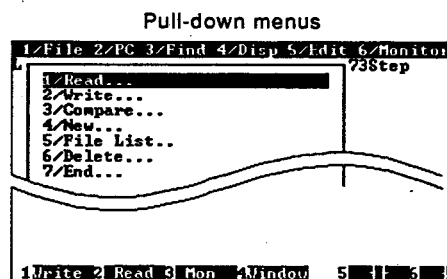

• Comprehensive Debugging Functions

(1) Comprehensive ladder monitor functions

- (a) Index-qualified devices and expansion file registers can be monitored.
- (b) The peripheral device designates the QnACPU monitoring timing, to allow precise monitoring timing. At the designated timing, the peripheral device reads and displays the monitored information.

<Example>

Monitoring timing set at 200 steps and M100 leading edge.

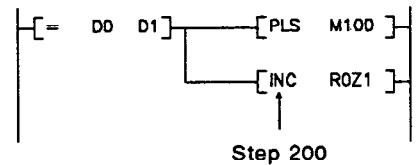
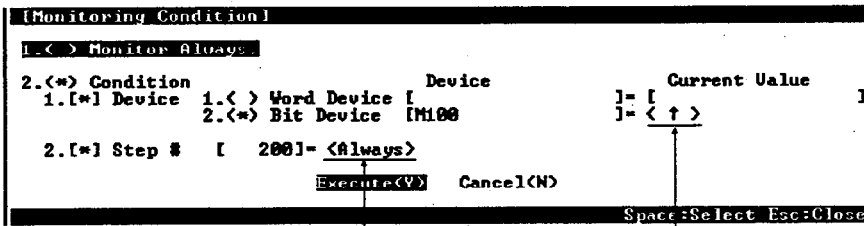

Sets the ON condition of the designated step as "Always, ON, OFF, leading edge (↑) or trailing edge (↓)". A setting made during operation (between contacts) is valid.

Sets the designated bit device status as leading edge (↑) or trailing edge (↓).

Monitor only when ADN is established.

(2) Debugging by multiple people

Debugging is possible using multiple peripheral devices connected to a single QnACPU.

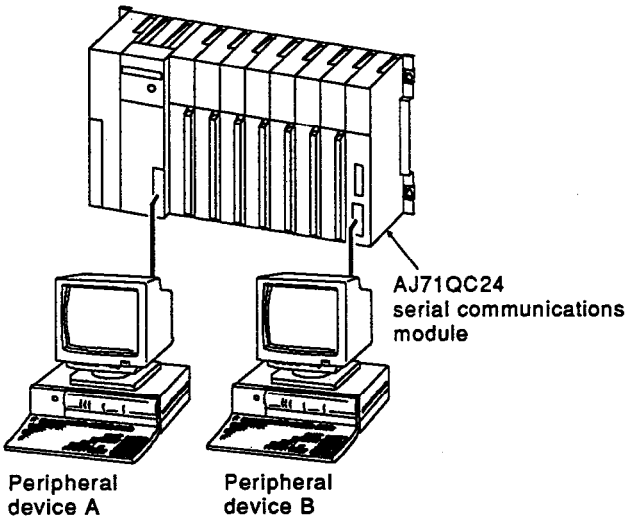

- (a) If each peripheral device debugs a separate file name, monitoring, testing, and online program change (write during RUN) can be conducted freely, without affecting any other peripheral device. For example, if peripheral device A debugs "Machining program" and peripheral device B debugs "Assembly program."
- (b) Also, online program change (write during RUN) is possible for the same file from multiple peripheral devices. A program pointer must be pre-designated for the online program change (write during RUN) programs.

- Simple Programming
Powerful document-creation support
- (1) Integral management of statements and notes with the program.
 - (2) Comments can be added to all devices.
 - (3) Comments up to 32 characters and labels up to 10 characters improve program readability.

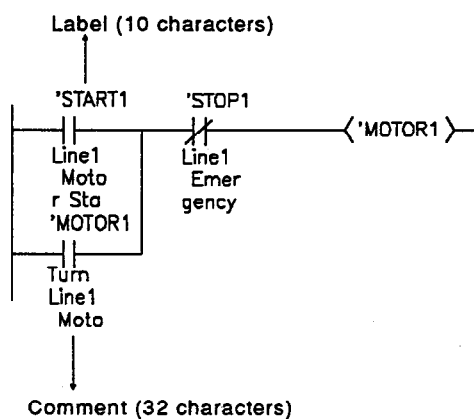

3. OPERATING PROCEDURE USING THE QnACPU

This chapter describes the basic operation of the QnACPU and the preparations and procedures required before operation.

3.1 Applicable System Configuration

The diagram shows the example system used for the following explanations. The peripheral device used is an IBM PC/AT.

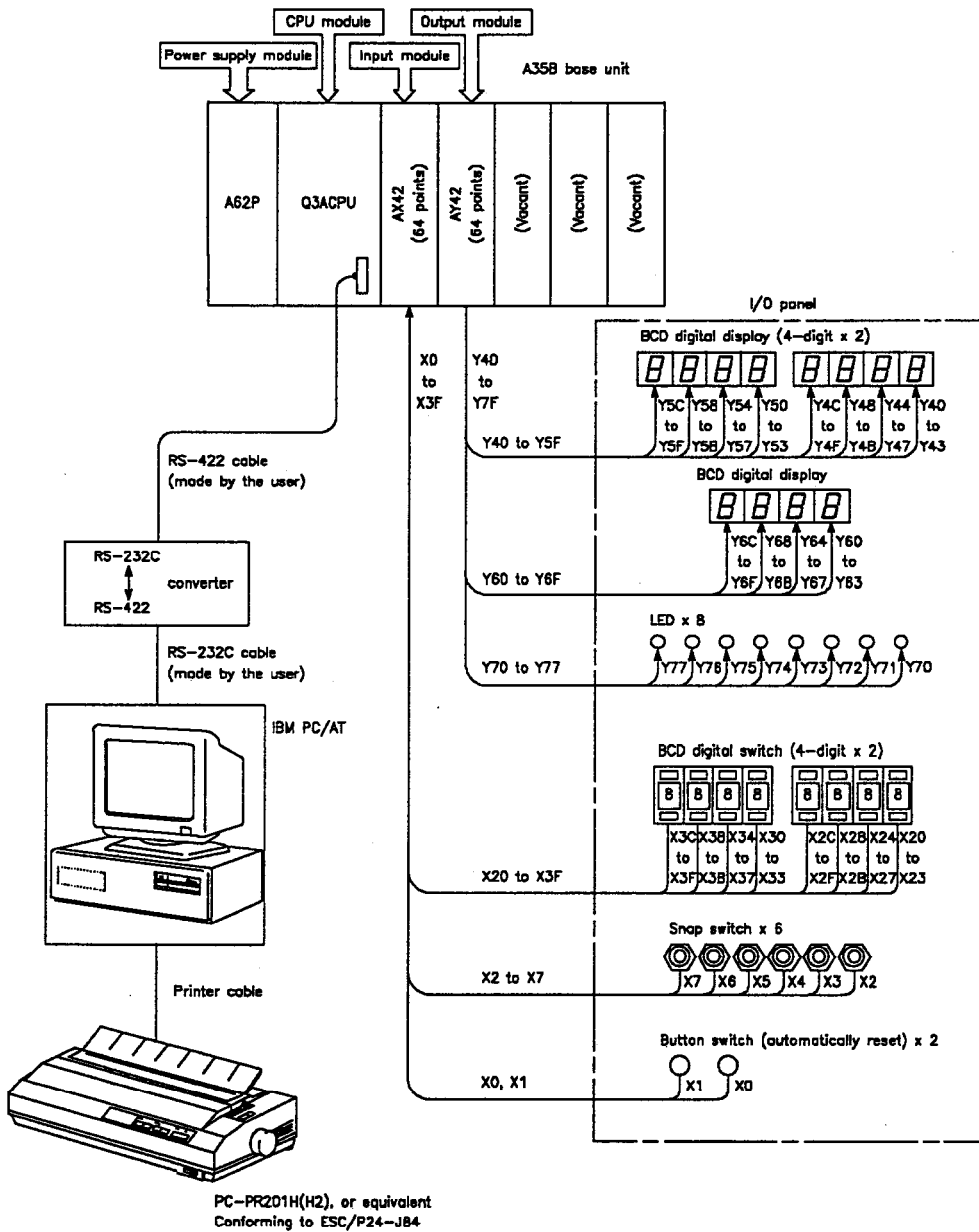

POINT

This guide uses an example of connection to the PC CPU via the built-in RS-232C port.

3.2 General Procedure for Overall Operation

The overall procedure for the basic QnACPU operations described from Section 3.3. The peripheral device is an IBM PC/AT.

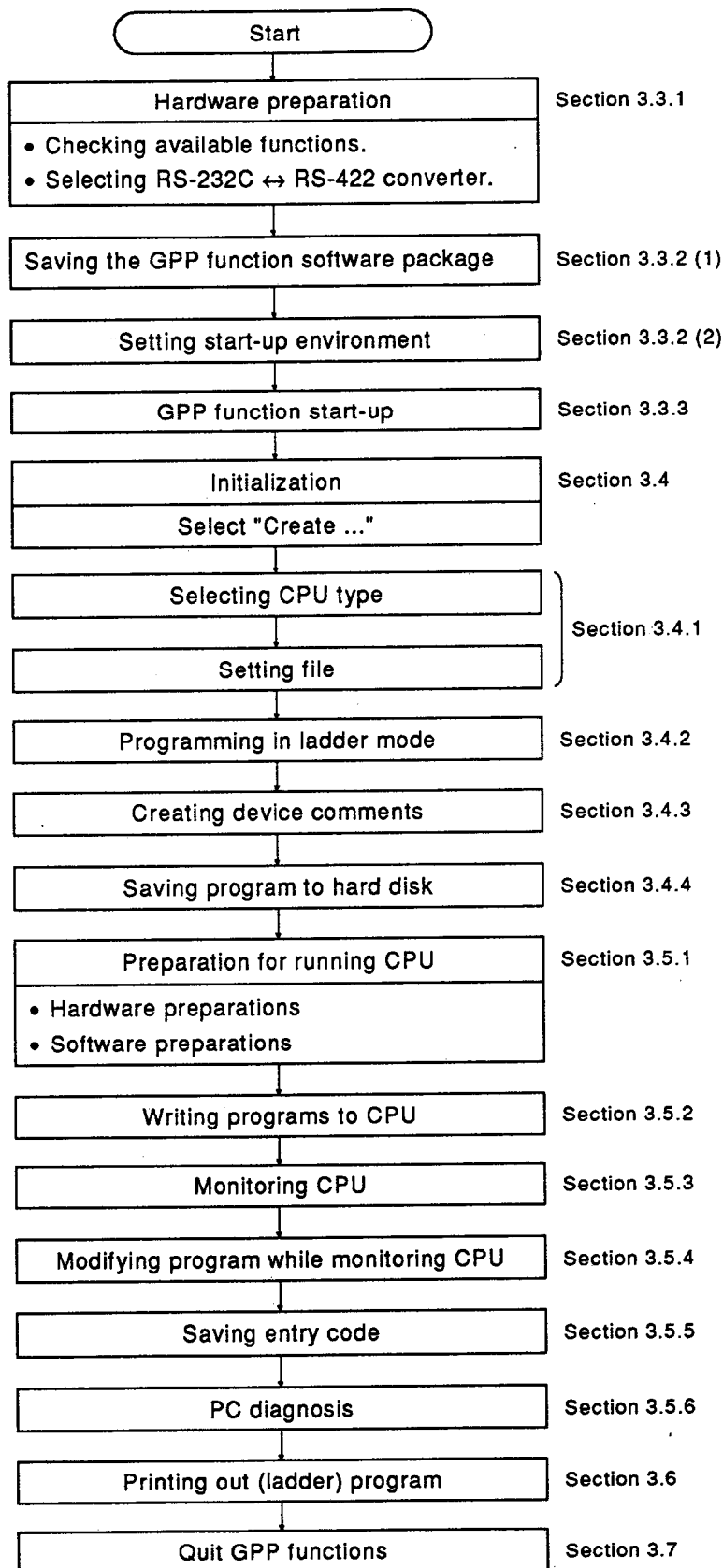

3.3 Starting Up GPP Functions after Completing Peripheral Device Preparations

The peripheral device hardware settings must be made and the GPP function software package must be set before running the GPP functions.

3.3.1 Preparing the IBM PC/AT hardware

The system configuration is shown below.

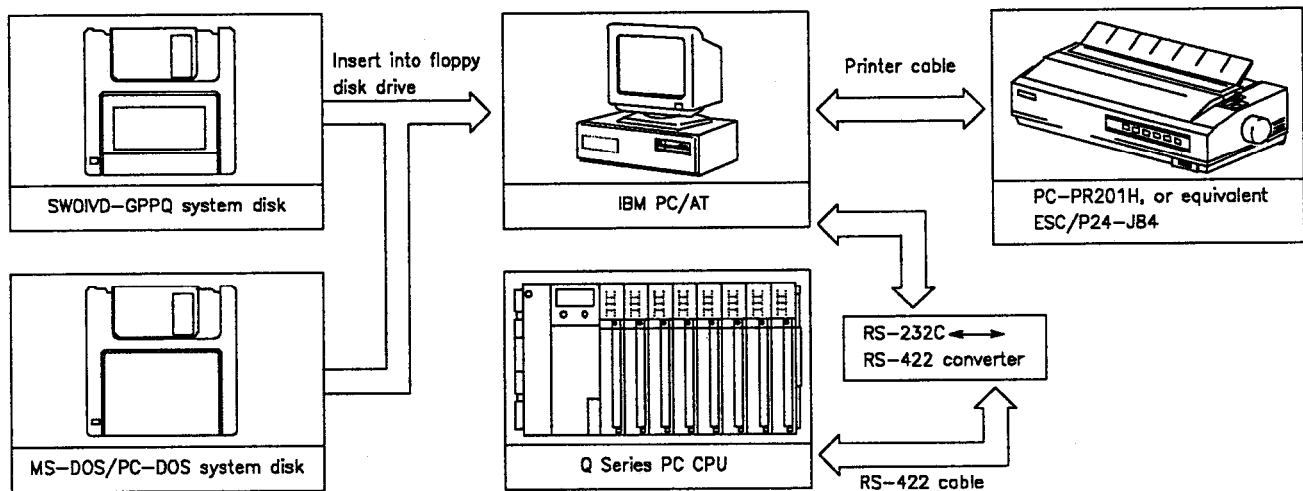

(1) Applicable IBM PC/AT

The following IBM PC/AT specifications can be used.

CPU : 80486SX(20 MHz), or higher (recommended: 80486DX2 (66 MHz))

EMS : 4 MB min.

Hard disk free space : 20 MB min.

Other : Install HIMEM and SMARTDRV drivers.

(2) MS-DOS/PC-DOS operating system disk

Start the operating system disk before starting the personal computer. This system uses the MS-DOS or PC-DOS operating system.

Check that the version of the MS-DOS/PC-DOS operating system is version 5.0 or later.

(3) Free space in main memory

At least 540 k bytes free space is required in the main memory of the IBM PC/AT used.

(4) SW0IVD-GPPQ software package

This system disk provides the software package which is installed onto the IBM PC/AT hard disk to run the GPP functions (sequence program environment part) and SFC functions.

The software package is contained in the following disks.

- 3.5-inch disks
- SW0IVD-GPPQ-1 2 floppy disks
- SW0IVD-GPPQ-2 1 floppy disk
- SW0IVD-GPPQ-3 1 floppy disk

SW0IVD-GPPQ-1 is copy protected.

Installation of the software package requires 8 M byte minimum of free space on the hard disk.

(5) RS-232C ↔ RS-422 converter

The computer and the QnACPU are connected by means of an RS-232C ↔ RS-422 converter.

Shown below is an example of the connections between the computer and the QnACPU through the RS-232C ↔ RS-422 converter. (Connect the wires to the RS-232C ↔ RS-422 as illustrated in the following figure.)

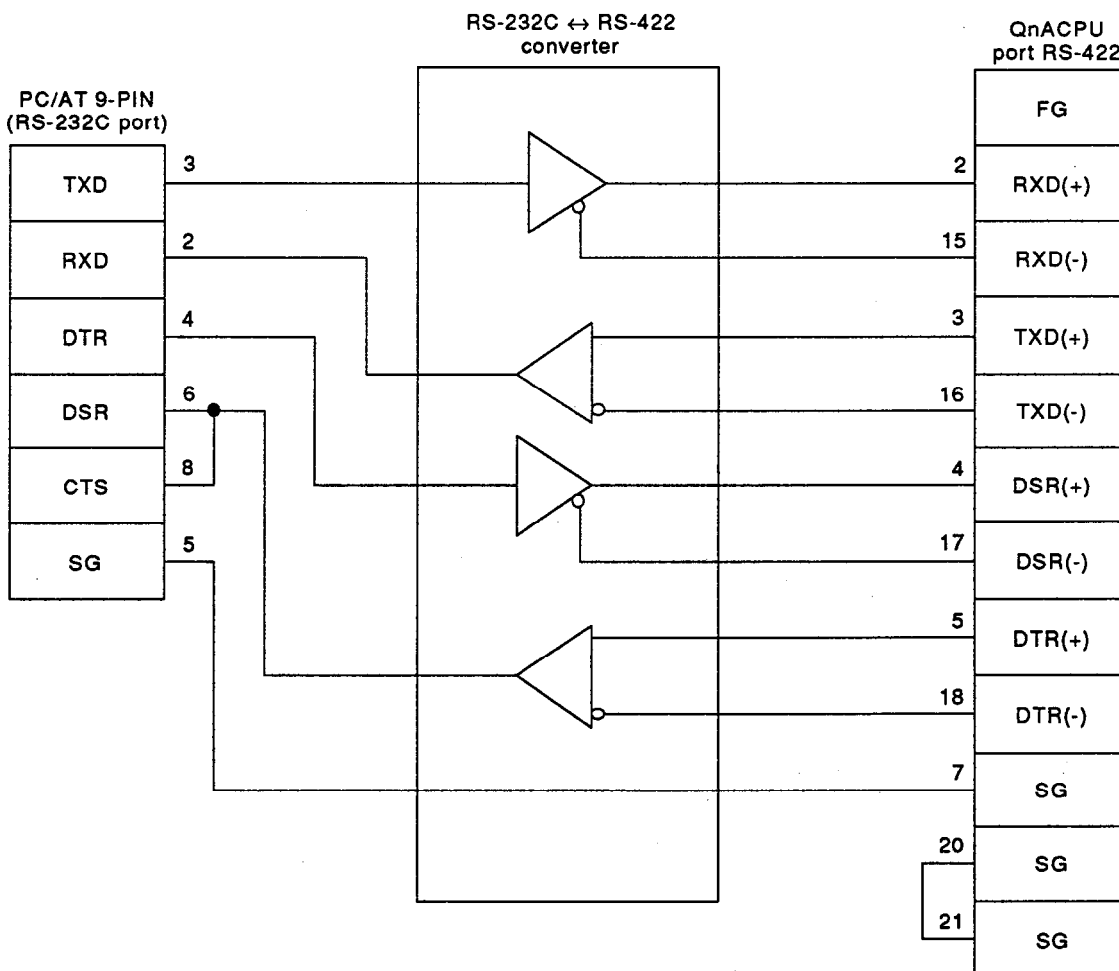

3.3.2 Installing the GPP function software package

(1) Installation procedure

This section describes the procedure to install SW01VD-GPPQ on the IBM PC/AT hard disk.
The installation is based on the conditions shown below.

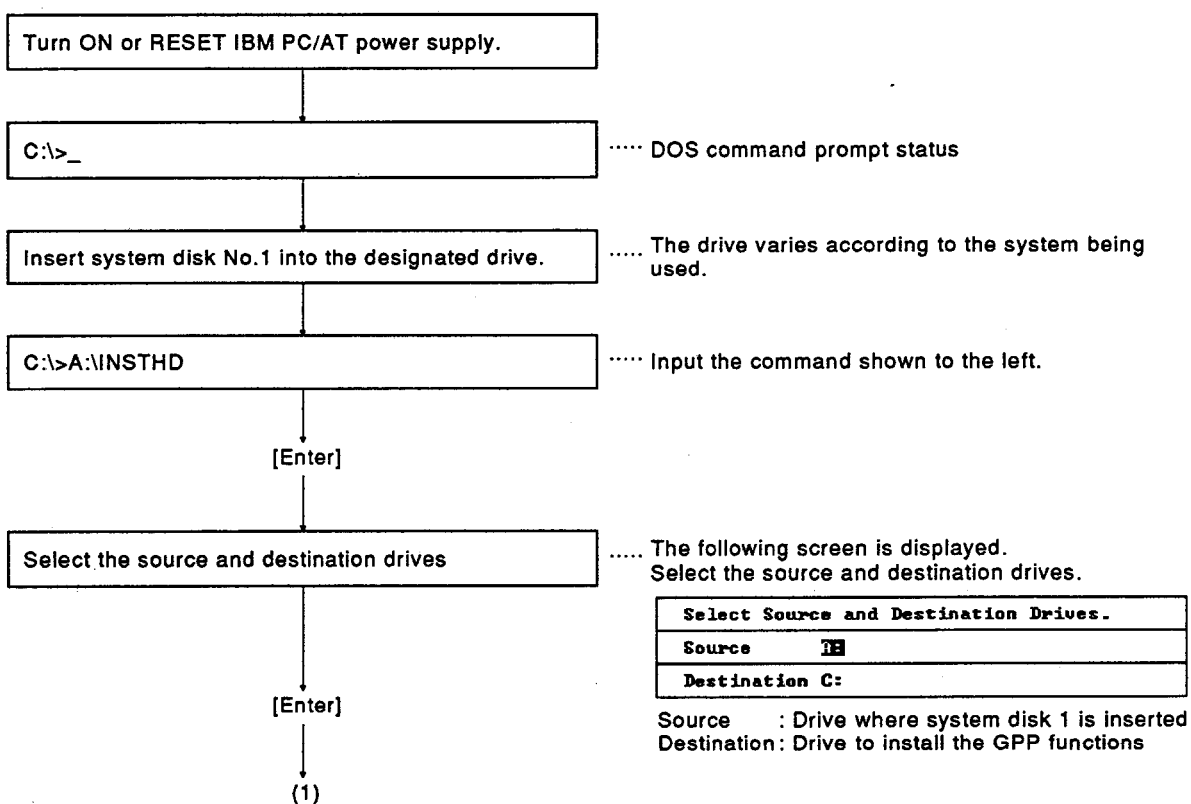

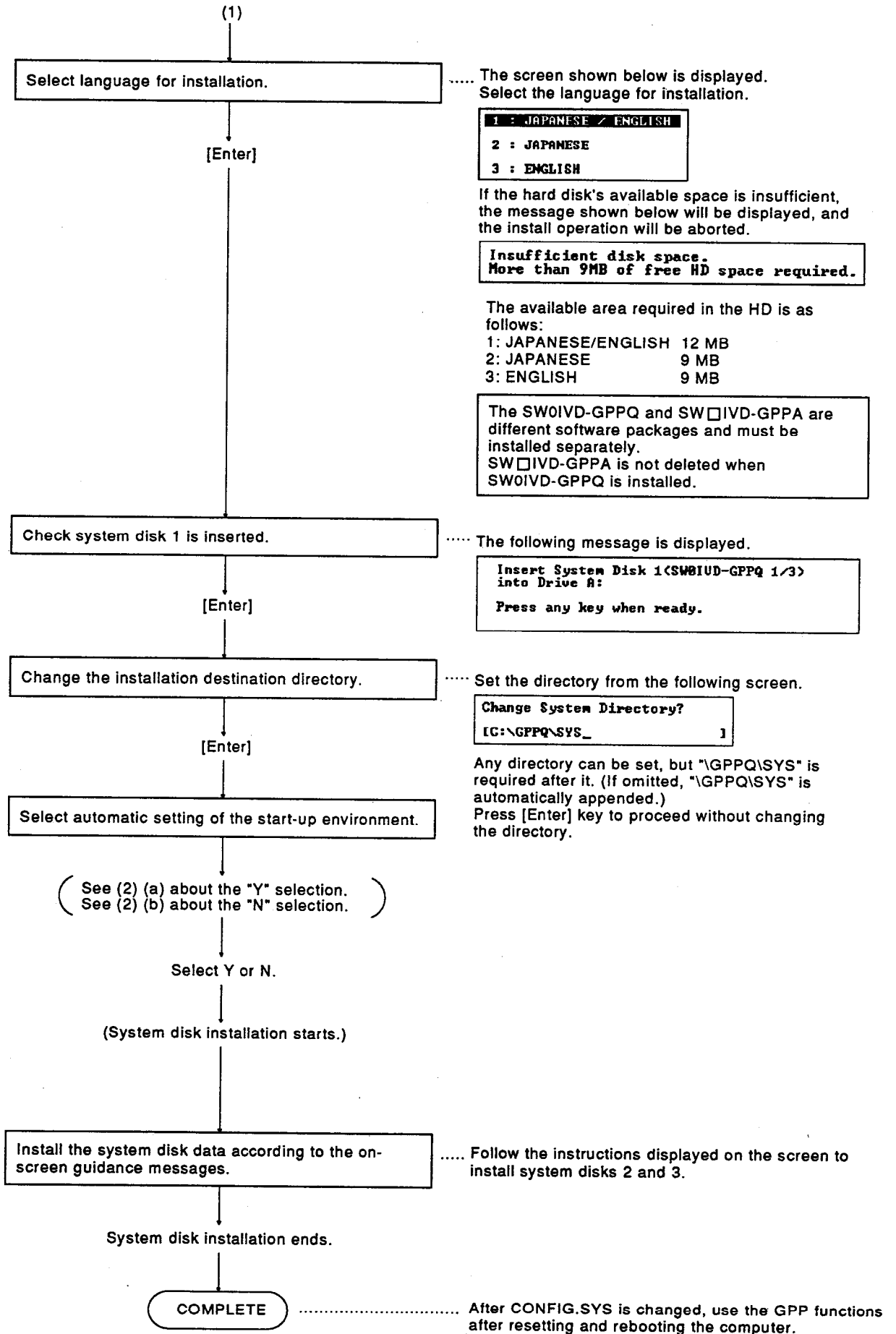

(2) Setting the Start-up environment

Environment settings using CONFIG.SYS are required before starting the GPP functions.

(a) Automatic set-up

The following message is displayed during installation of the software package.

```
Sets Environment Variables.  
Modifies CONFIG.SYS.  
Perform Modification<Y/N>?
```

Press [Y] then [Enter] to change FILES (number of files) in CONFIG.SYS to 30.

However, if FILES is already greater than 30, no change is made and the original data is used.

The CONFIG.SYS settings before the changes are saved as CONFIG.ORG.

Note that any existing CONFIG.ORG file is overwritten.

(b) User set-up

The user must set the GPP function start-up environment if "N" is selected in response to the message prompting whether to make the automatic settings after the software package is installed.

The following CONFIG.SYS, AUTOEXEC.BAT settings are required to start up the GPP functions.

<Example>PC-DOS Ver. 5.0

```
[CONFIG.SYS]  
FILES=30  
BUFFERS=20  
DOS=HIGH, UMB*1  
COUNTRY=081, 932, C:\DOS\CONTRY.SYS  
SHELL=C:\DOS\COMMAND.COM /P /E:512  
DEVICE=C:\DOS\FONT.SYS /24=ON  
DEVICE=C:\DOS\HIMEM.SYS  
DEVICE=C:\DOS\EMM386.EXE 4096 RAM FRAME=E000*2  
DEVICE=C:\DOS\DISP.SYS  
DEVICE=C:\DOS\IAS.SYS  
DEVICE=C:\DOS\ANSI.SYS /X  
  
[AUTOEXEC.BAT]  
@ECHO OFF  
C:\DOS\SMARTDRV.EXE /X*3  
PATH C:\WINDOWS;C:\DOS;C:\  
SET TEMP=C:\TMP  
SET DOSDIR=C:\DOS
```

*1: XMS manager (required for EMM386/SMARTDRV)

*2: Reserve 4 MB for EMS

*3: Enable the disk cache.

(c) Batch files

To start up the GPP functions, copy the following GPPQ.BAT batch file to the root directory.

The drive name is replaced by the drive name designated during system installation.

```
[GPPQ.BAT]
C:
CD C:\GPPQ\SYS
GPPQ.EXE
```

(3) Cautions about environment set-up

- (a) A minimum of 540 kbytes free space is required in main memory. Execution speed increases if more free space is available.
- (b) The conditions that have to be set in the CONFIG.SYS file to start up the GPP functions are as follows:
FILES: 30 or more
No other specific settings are required.
- (c) It is not necessary to incorporate PRINT.SYS (printer driver) and RSDRV.SYS (PC communications driver) into CONFIG.SYS. They are included in the GPP functions.
- (d) Incorporate PRINT.SYS into CONFIG.SYS to make hard copies.
- (e) More than 4 MB of EMS memory is required.
Configure your memory settings according to your system.

3.3.3 Starting the GPP functions

This section describes how to start up the GPP functions installed on the IBM PC/AT hard disk.

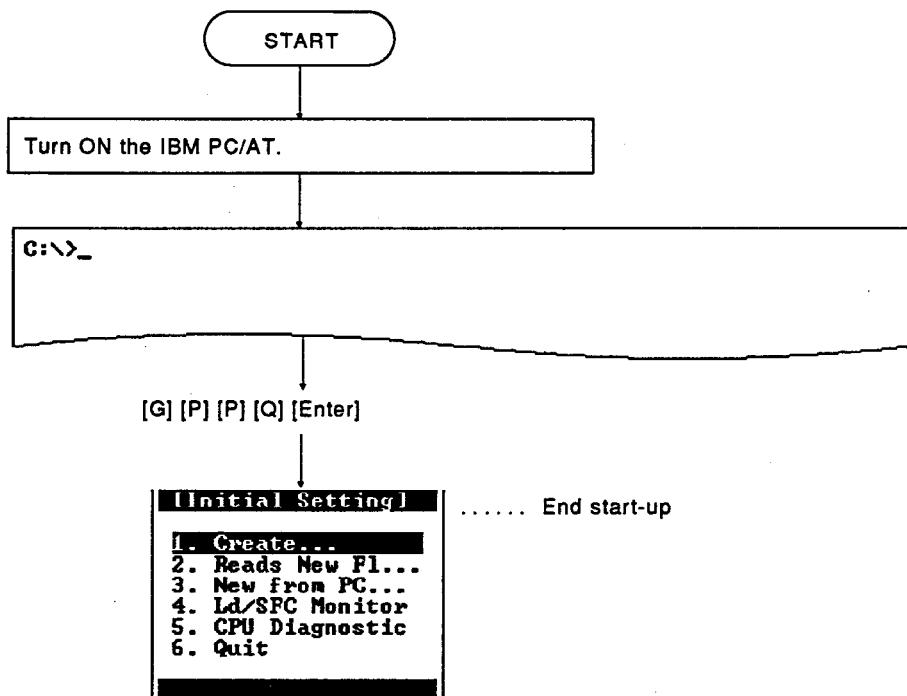

3.4 Creating Programs

Use screen operations after starting GPPQ.

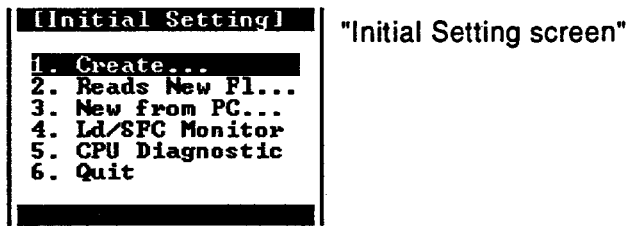

[1] Select "Create..."

To Section 3.4.1

3.4.1 Selecting CPU type used and setting file

The following screen is displayed after "Create..." is selected above. Press the key corresponding to the CPU type used. In this example, Q3ACPU is selected.

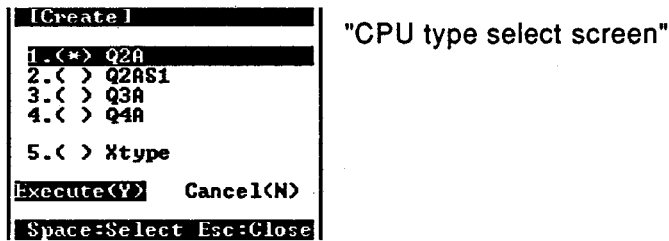

[3] Select "Q3ACPU"

[Enter]

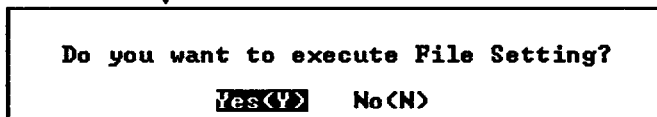

[Y] Select "Yes"

1)

[N] Select "No"

2)

1)

2)

[Create]				
1. Drive/Path	IC:\GPPQ\USR]
2. System	[A-LINE]	Title	[TRANSFER]
3. Machine	[C]	Title	[CONVEYOR]
4. File	[PC]	Title	[Q-CPU]
		Execute<Y>	Cancel<N>	
Ctrl+L=List Ctrl+D=Dir Space=Select Esc=Close				

Drive and path are default values.

[↓] [SP] [A] [-] [L] [I] [N] [E] [Tab]

[T] [R] [A] [N] [S] [F] [E] [R] [Enter]

[SP] [C] [Tab]

[C] [O] [N] [V] [E] [Y] [O] [R] [Enter]

[SP] [P] [C] [Tab] [Q] [-] [C] [P] [U] [Enter]

"File setting screen"

The characters and symbols used in the system name, machine name, file name, and title are unrestricted.

[Y] Select "Execute"

The system name doesn't exist.
Do you want to create it?

Yes<Y> No<N>

The following dialog box is displayed if the system name already exists.

The machine name doesn't exist.
Do you want to create it?

Yes<Y> No<N>

[Y] Select "Yes"

[N] Select "No"

"Processing" is displayed.

Return to the CPU type select screen.

0/SFC

1/Ladder

2/List

3/Parameter

4/Device

5/On-line

6/PC Diagnostic

7/Documentation

8/Printer

9/File Maintenance

A/Program Generation

B/Initial Setting

C/Option

D/DOS

F/Quit

"Mode Select screen"

3.4.2 Programming in ladder mode

The procedure for programming in the ladder mode is shown below.

(1) About the program

The program created to automatically run the conveyor is shown in Fig. 3.2.

(2) Description of operation

The operation of the program to automatically run the conveyor is outlined below.

When the workpiece (pallet) stops in front of the conveyor, a warning buzzer sounds for 3 seconds and the conveyor automatically starts. The conveyor stops after it has transported 6 products onto the workpiece. The workpiece is automatically transferred to the next process, the products unloaded, and then returns to the position in front of the conveyor.

The flowchart for this procedure appears as follows.

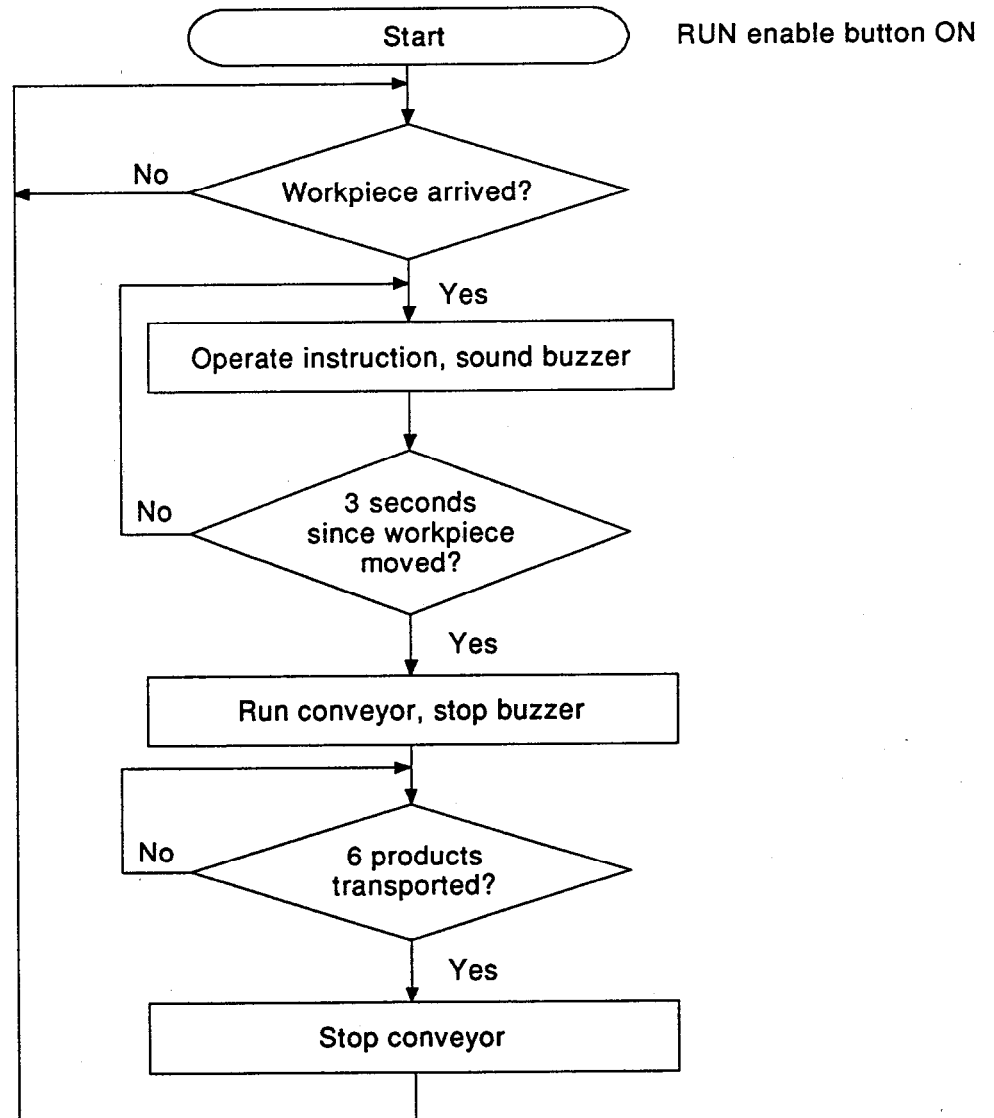

(3) Allocation of devices

- X0.... RUN enable button
- X1.... STOP button
- X2.... Work sensor
- X3.... Product sensor
- Y70... Buzzer output
- Y71... Conveyor Operation
- M0 Operation command
- M1 Operation record
- M10 Operating enable
- M11 Record operation enable
- T0..... Warning timer
- C0..... Product count

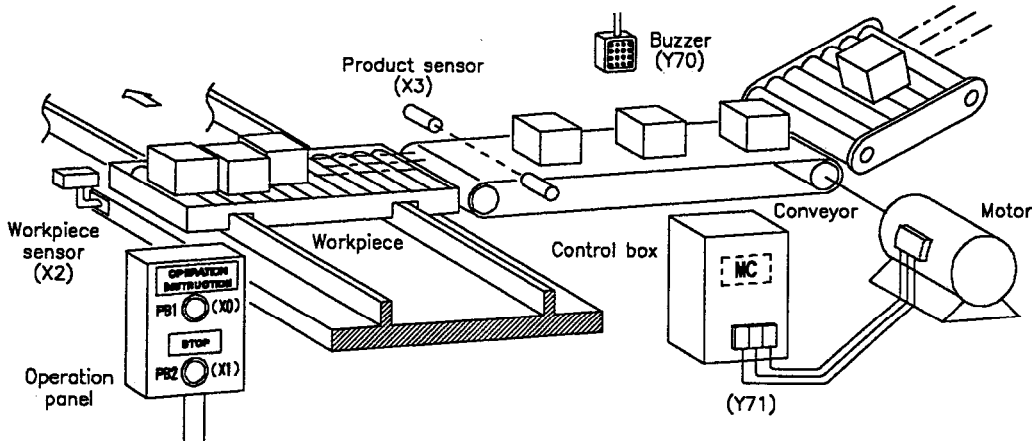

Fig. 3.1 Automatic Transport Equipment

(4) Program for automatic conveyor operation

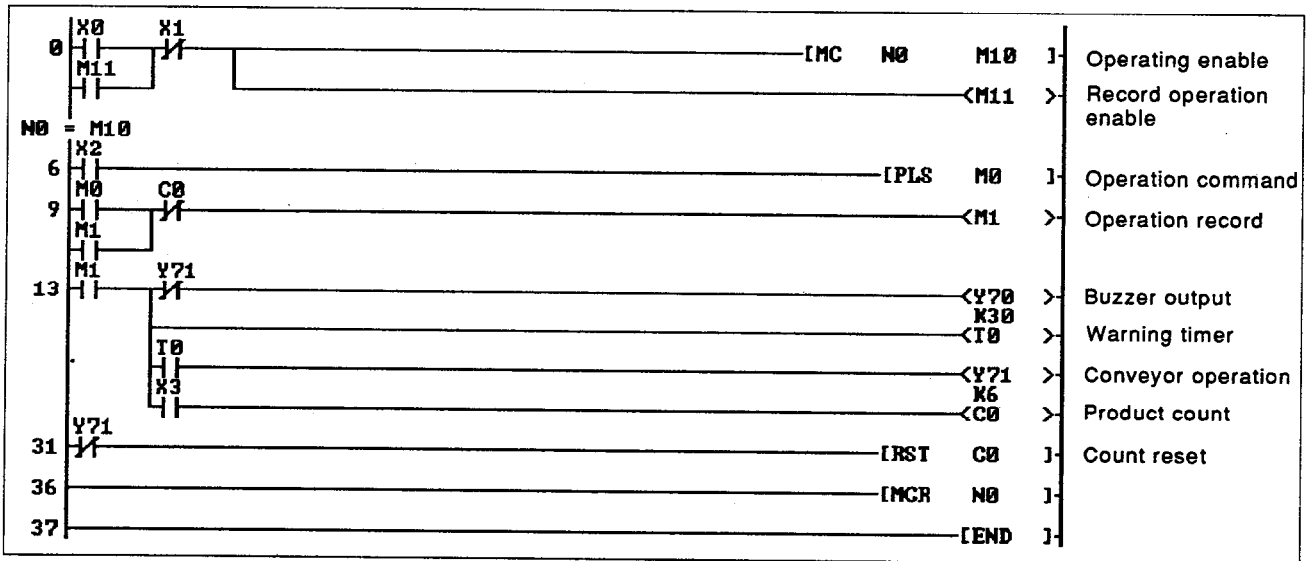
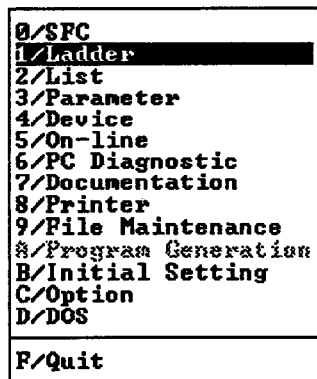

Fig. 3.2 Program for Automatic Conveyor Operation

(5) Programming procedure

The program is created using ladder symbols.
Operation starts from the mode select screen.



"Mode Select screen"

[1] Select "Ladder"

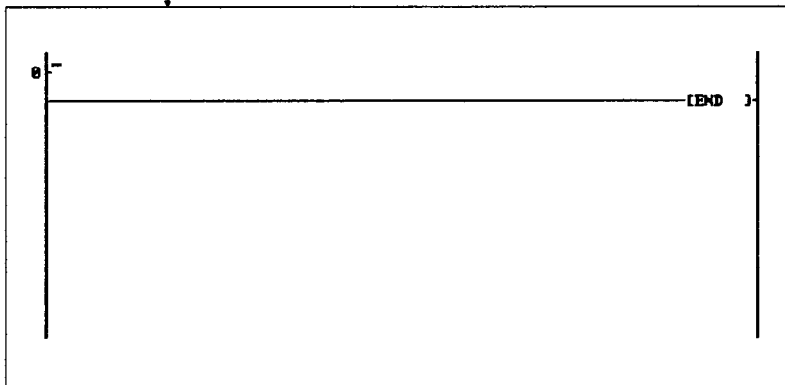

"Ladder Write (insert mode) screen"

1)

It is unnecessary to write MC contacts in the bus line. They are displayed on the screen after pressing [F4] (Convert) key followed by [F2] key to select the read mode.

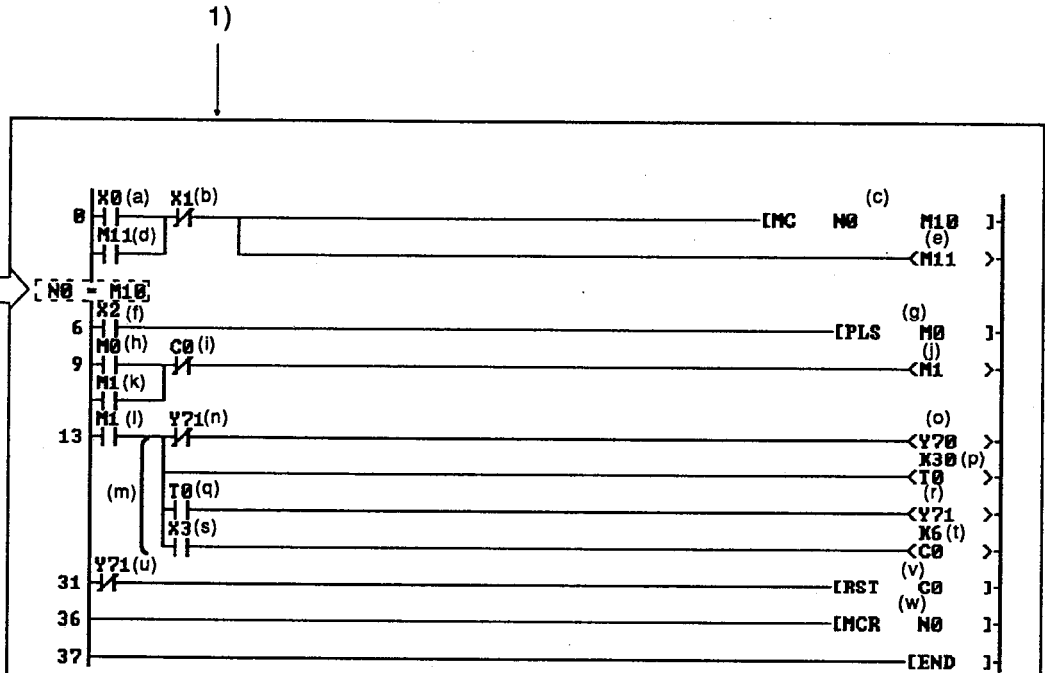

[Key input sequence (a) to (w)]

- (a) [F5] [X] [0] [Enter]
(←)
- (b) [F6] [X] [1] [Enter]
(←)
- (c) [F8] [M] [C] [SP] [N] [0] [SP] [M] [1] [0] [Enter]
(←)
- (d) [Shift] + [F5] [M] [1] [1] [Enter]
(←)
- (e) [→] [↑] [Insert] [Shift] + [F9] [Enter] [↓] [Insert]
(overwrite) () (insert)
[F7] [M] [1] [1] [Enter]..... Create vertical line in the
(←) overwrite mode
- (f) [F5] [X] [2] [Enter]
(←)
- (g) [F8] [P] [L] [S] [SP] [M] [0] [Enter]
(←)
- (h) [F5] [M] [0] [Enter]
(←)
- (i) [F6] [C] [0] [Enter]
(←)
- (j) [F7] [M] [1] [Enter]
(←)
- (k) [Shift] + [F5] [M] [1] [Enter]
(←)
- (l) [←] [Shift] + [F9] [Enter] [↓] [F5] [M] [1] [Enter]
() (←)
- (m) [Shift] + [F9] [3] [Enter] Write continuous vertical lines
()
- (n) [F6] [Y] [7] [1] [Enter]
(←)

2)

2)



- (o) [F7] [Y] [7] [0] [Enter]
(←)
- (p) [→] [F7] [T] [0] [SP] [K] [3] [0] [Enter]
(←)
- (q) [→] [F5] [T] [0] [Enter]
(←)
- (r) [F7] [Y] [7] [1] [Enter]
(←)
- (s) [→] [F5] [X] [3] [Enter]
(←)
- (t) [F7] [C] [0] [SP] [K] [6] [Enter]
(←)
- (u) [F6] [Y] [7] [1] [Enter]
(←)
- (v) [F8] [R] [S] [T] [SP] [C] [0] [Enter]
(←)
- (w) [F8] [M] [C] [R] [SP] [N] [0] [Enter]
(←)
- () [F4] Convert
(Convert)

Do not forget to press the [F4] (Convert) key or the entered program will be lost.



3.4.3 Appending comments to devices

Operation from the mode select screen.
 [To conduct further operations after creating a sequence program, press [F11] key to display the mode select screen.]

```

0/SFC
1/Ladder
2/List
3/Parameter
4/Device
5/On-line
6/PC Diagnostic
7/Documentation
8/Printer
9/File Maintenance
A/Program Generation
B/Initial Setting
C/Option
D/DOS

F/Quit
    
```

"Mode Select screen"

[7] Select "Documentation"

```

1/File 2/PC 3/Find 5/Edit 7/Window 8/Option          Alt:Menu  F12:Help
Document Device CPU:Q3A          C:KIKAI_G1MAIN  <Ins>      F11:Mode
Device          Comment          Device Label
12345678901234567890123456789012  1234567890
X 0 [Operating Enable ] IPB1 ]
X 1 [Stop ] IPB2 ]
X 2 [Work Sensor ] [ ] ]
X 3 [Product Sensor ] [ ] ]
X 4 [ ] [ ] ]
X 5 [ ] [ ] ]
X 6 [ ] [ ] ]
X 7 [ ] [ ] ]
X 8 [ ] [ ] ]
X 9 [ ] [ ] ]
X A [ ] [ ] ]
X B [ ] [ ] ]
X C [ ] [ ] ]
X D [ ] [ ] ]
X E [ ] [ ] ]
X F [ ] [ ] ]
X 10 [ ] [ ] ]
X 11 [ ] [ ] ]

1)Device 2) 3) Window 4)Find 5)Select 6) Cut 7) Copy 8)Paste 9) Undo
    
```

"Documentation screen"

- [Input X0 comment]
[O] [p] [e] [r] [a] [t] [i] [n] [g] [E] [n] [a] [b] [l] [e]
 - [Input X0 device label]
[Tab] [P] [B] [1]
 - [Input X1 comment]
[Tab] [S] [t] [o] [p]
 - [Input X1 device label]
[Tab] [P] [B] [2]
 - [Input X2 comment]
[Tab] [W] [o] [r] [k] [S] [e] [n] [s] [o] [r] [Enter]
- Similarly, create the X3 comment

1)

1)

[F1] Device

[Device]

1. Device [Y70]

Execute<Y> Cancel<N>

Esc:Close

[Input device designation]
 [Y] [7] [0] [Enter] Designate Y70

[Y] Execute

Document	Device	Device	CPU:Q3A	Comment	C:KIMAI_G1\MAIN	Alt:Menu	F12:Help
						<Ins>	F11:Mode
	Y	70	[12345678901234567890123456789012]	[1234567890
	Y	71	[]	[]
	Y	72	[]	[]
	Y	73	[]	[]
	Y	74	[]	[]
	Y	75	[]	[]
	Y	76	[]	[]
	Y	77	[]	[]
	Y	78	[]	[]
	Y	79	[]	[]
	Y	7A	[]	[]
	Y	7B	[]	[]
	Y	7C	[]	[]
	Y	7D	[]	[]
	Y	7E	[]	[]
	Y	7F	[]	[]
	Y	80	[]	[]
	Y	81	[]	[]

"Documentation screen"

Repeat the procedure on the previous page for X device comments to create the Y device comments.
 Then, follow the same procedure to create the comments for M, T, and C devices.

End

3.4.4 Saving program to hard disk

Save the sequence program created in Section 3.4.2 to the hard disk.
This operation starts from the screen displayed after conversion.

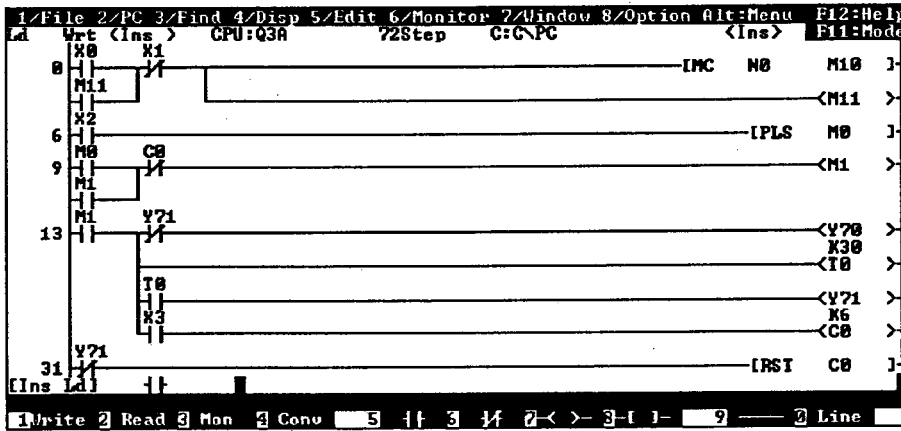

"Ladder Write (insert) screen"

[Alt] Menu

[1] Select "File"

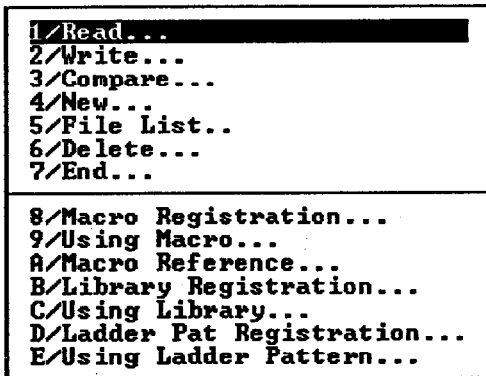

"File access screen"

[2] Select "Write"

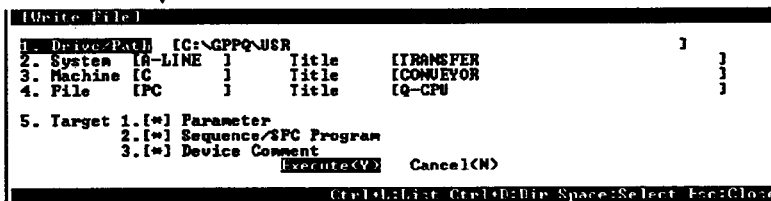

"Write File screen"

The system name, machine name, and file name set in Section 3.4.1 are automatically displayed.

1)

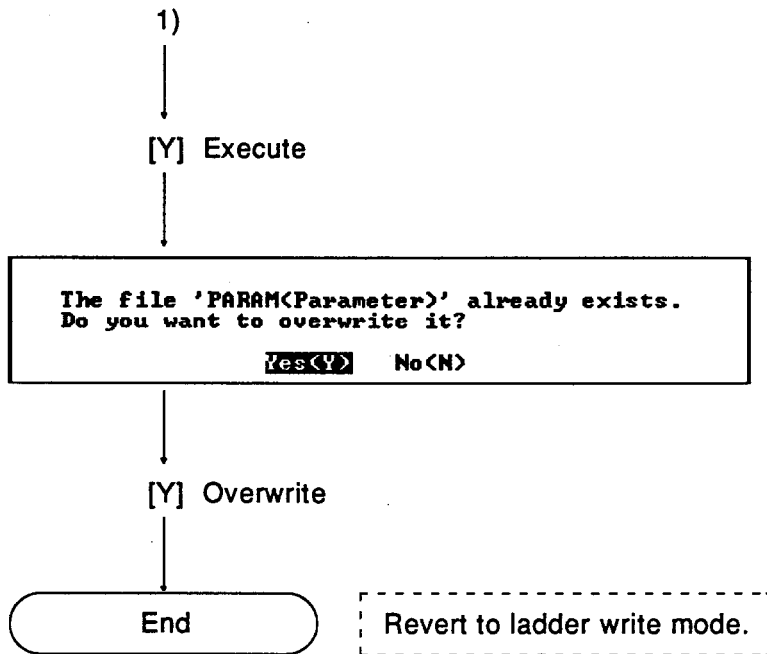

POINT

The following system name, machine name, and file name defaults are used if no file is set:

- System name [SYSTEM]
- Machine name [KIKAI_G1]
- File name [MAIN]

The default drive and path is "C:\GPPQ\USR".

3.4.5 Convenient functions for programming

The parallel coil, line, and cut and paste editing are convenient functions for programming in the ladder mode.

(1) Parallel coils

When coil-equivalent instructions (←→, ⇄) are input, the vertical lines and parallel coils are created automatically to create a ladder block. The ladder block below was created using parallel coils.

[Operations in the ladder write (insert) mode.]

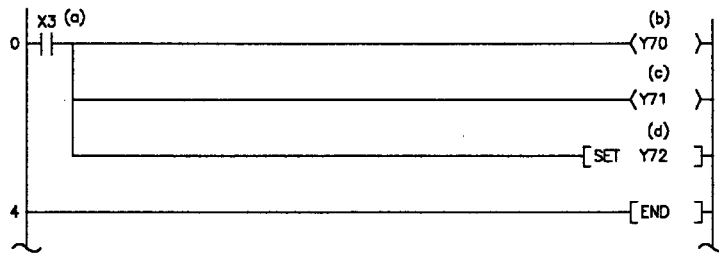

[Key input sequence (a) to (d)]

(a) [F5] [X] [3] [Enter]
(←→)

(b) [F7] [Y] [7] [0] [Enter]
(←→)

(c) [→] [↑] [F7] [Y] [7] [1] [Enter]..... Write parallel coils
(←→)

(d) [→] [↑] [F8] [S] [E] [T] [SP] [Y] [7] [2] [Enter]
..... (⇄)..... Write parallel coils

(e) [F4] Convert
(Convert)

(2) Lines

A ladder block can be created using lines.
The ladder block below was created using lines.

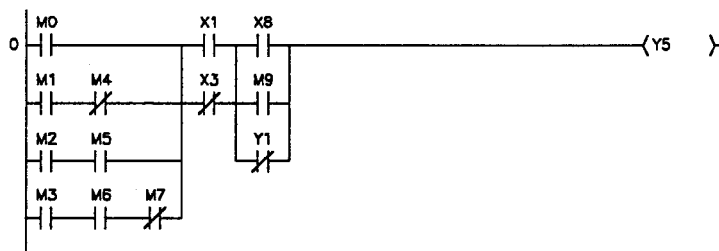

(a) Provide space before the END instruction for the ladder.

Operations in the ladder write (insert) mode.

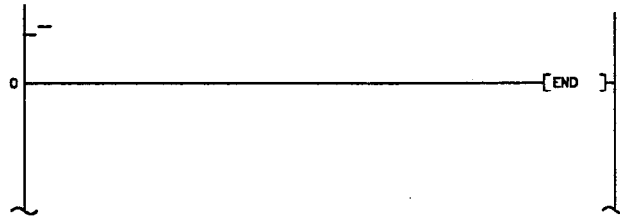

↓ [Shift] + [F9] [3] [Enter] Reserve space for write operation
(i)

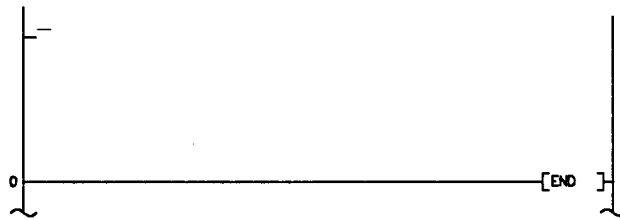

(b) Draw lines as shown in the diagram below.

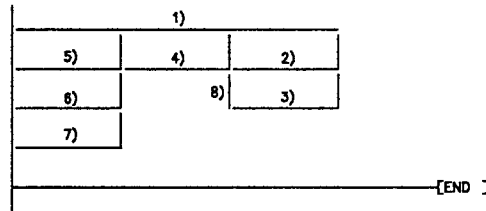

[Key input sequence 1) to 8)]

- 1) [F10] [Enter] [→] [→] [Enter]
(Line) (Start) (Designate — line, repeat 9 times) (End)
- 2) [Esc] [Esc] [Enter] [↓] [←] [←] [←] [Enter]
(Continue) (Start) (Designate — line) (End)
- 3) [→] [→] [→] [Enter]
(Designate copy destination)
- 4) [↑] [←] [←] [←] [Enter]
(Designate copy destination)
- 5) [←] [←] [←] [Enter]
(Designate copy destination)
- 6) [↓] [Enter]
(Designate copy destination)
- 7) [↓] [Enter]
(Designate copy destination)
- 8) [Esc] [Esc] [→] [→] [→] [Enter] [↑] [Enter]
(Continue) (Create position) (Start) (End)

Copy line (2)

(c) Write contacts and coils on lines

Operations in the ladder write (overwrite) mode.
 To continue after operation (b), press the [Esc] key three times to cancel the line mode and press the [Insert] key to select the ladder write (overwrite) mode.

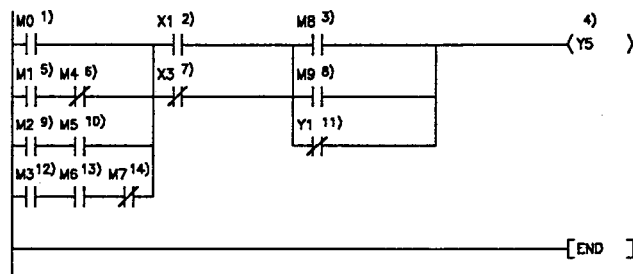

[Key input sequence 1) to 14)]

- 1) [F5] [M] [0] [Enter]
(←)
- 2) [→] [→] [F5] [X] [1] [Enter]
(←)
- 3) [→] [→] [F5] [M] [8] [Enter]
(←)
- 4) [→] [→] [F7] [Y] [5] [Enter]
(←)
- 5) [F5] [M] [1] [Enter]
(←)
- 6) [F6] [M] [4] [Enter]
(≠)
-
- 11) [→] [→] [F6] [Y] [1] [Enter]
(Input 5 times)
- 12) [↓] [←] [←] [F5] [M] [3] [Enter]
(Input 7 times)
- 13) [F5] [M] [6] [Enter]
(←)
- 14) [F6] [M] [7] [Enter]
(≠)
-) [F4] Conversion
(Convert)

COMMENT

It is also possible to first draw the contact and coil instruction symbols and subsequently draw the lines. In this case, lines cannot overwrite instruction symbols.

POINTS

- Horizontal, vertical, line, and lines can be drawn by a single operation. Rectangles, lines, and lines cannot be drawn using a single operation.
- Lines can be copied to any position by designating the destination.
- Lines and contact positions can be drawn as required. Line lengths and contact positions are corrected during conversion.

(3) Cutting and pasting

Parts of ladder programs can be cut and pasted.

The cutting and pasting operations can be conducted in the following units:

- ladder lines
- ladder blocks
- ladder program sections

(a) Cutting and pasting ladder lines

These operations are possible by selecting Edit from the menu or by selecting the ladder edit (insert/overwrite) mode with the functions keys.

1) Operations by selecting Edit from the menu

Select the ladder write (insert/overwrite) mode. (The operations are also possible in the ladder edit (insert/overwrite) mode.)

- Cut [Alt] → [5] → [1] → [↑]/[↓] → [Enter]
(Menu) (Edit) (Cut) (Designate start)
→ [↓]/[↑] → [Enter]
(Designate range) (Cut)
- Paste [Alt] → [5] → [3] → [↑]/[↓]
(Menu) (Edit) (Paste) (Designate paste destination)
→ [Enter]
(Paste)
- Conversion [F4]
(Convert)

2) Operations by selecting the ladder edit (insert/overwrite) mode with the functions keys

- Cut [Shift] + [F1] → [↑]/[↓] → [Shift] + [F6]
(Edit) (Designate start) (Select line)
→ [↑]/[↓] → [F7]
(Designate range)(Cut)
- Paste [↓]/[↑] → [F9]
(Designate paste destination)(Paste)
- Conversion [F1] → [F4]
(Write) (Convert)

(b) Cutting and pasting ladder blocks

Operation by selecting Edit from the menu.

Select the ladder read mode.

- Cut [Alt] → [5] → [1] → [↑]/[↓] → [Enter]
(Menu) (Edit) (Cut) (Designate start)
→ [↓]/[↑] → [Enter]
(Designate range) (Cut)
- Paste [Alt] → [5] → [3] → [↑]/[↓]
(Menu) (Edit) (Paste) (Designate paste destination)
→ [Enter]
(Paste)
- Conversion Not required (Cut and paste changes are directly reflected in memory when [Enter] key is pressed.)

REMARK

The "Close up" setting affects the program after cut and paste, as follows:

"Close up" set. The part where a program is cut is closed up.
 (The number of program steps remains unchanged after the editing.)
 The part where a program is cut is not closed up but filled with NOP instructions. (The number of program steps after the editing increases by the number of steps cut and pasted.)

Method for closing up [Alt] → [8] → [4] → [1]
 [1] Close up the program after conversion.
 [2] Do not close up the program after conversion.

The default is "Do not close up".

(c) Cutting and pasting ladder program sections

Operations by selecting the ladder edit (insert/overwrite) mode with the function keys

- Cut [Shift] + [F1] → [↑]/[↓]/[←]/[→] → [F6]
 (Edit) (Designate cut position) (Select)
 → [↑]/[↓]/[←]/[→] → [F7]
 (Designate cut range) (Cut)
- Paste [↑]/[↓]/[←]/[→] → [F9]
 (Designate cut position) (Paste)
- Conversion [F1] → [F4]
 (Write) (Convert)

After cutting a pasting a program section, write the vertical and horizontal lines in the program section before conversion. Otherwise, a message will be displayed indicating that the ladder program is incomplete.

COMMENT

- A cut operation alone is equivalent to deleting ladder blocks, except that the cut ladder blocks are stored in buffer memory.
- A paste operation after a cut operation is equivalent to copying the cut ladder blocks from the buffer memory to the designated position.
- After a cut operation, pasting can be carried out any number of times. This allows the cut ladder blocks to be inserted into any number of programs.
- Cutting and pasting are also possible for instruction lists.

(d) Examples of cutting and pasting

As an example, cutting and pasting will be shown for the ladder program below. All operations act on units of ladder lines. The three lines at 1) are cut and pasted after ladder block 2). The operations are carried out in this example by selecting Edit from the menu.

Operations in the ladder write (insert/overwrite) mode.

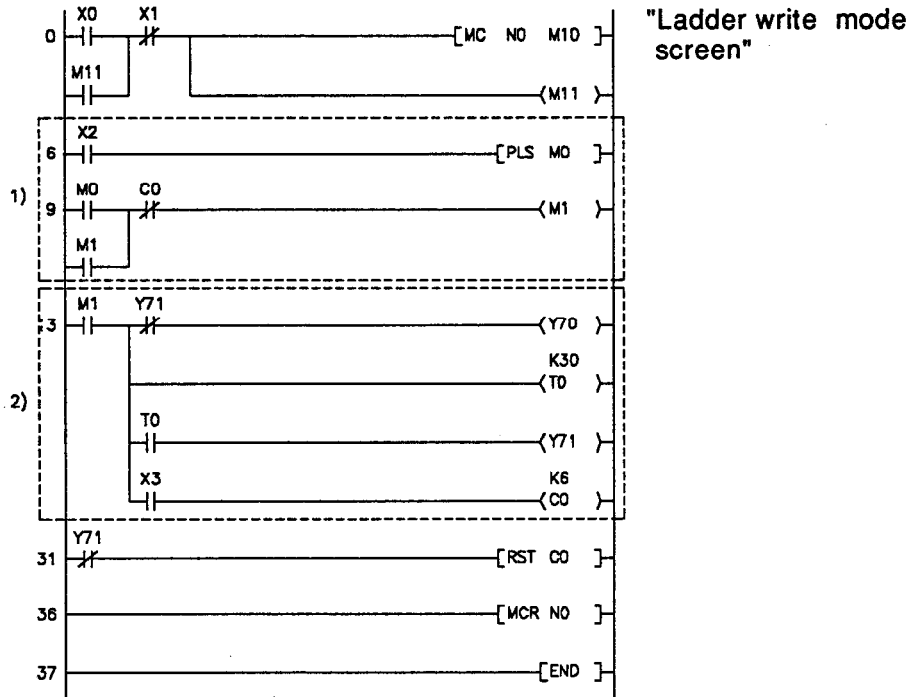

[Alt] [5] [1] [↓] [↓] [Enter] [↓] [↓] [Enter] .. The three lines at 1) are cut.
 (Menu)(Edit)(Cut) (Designate cut start) (Designate range) (Cut)

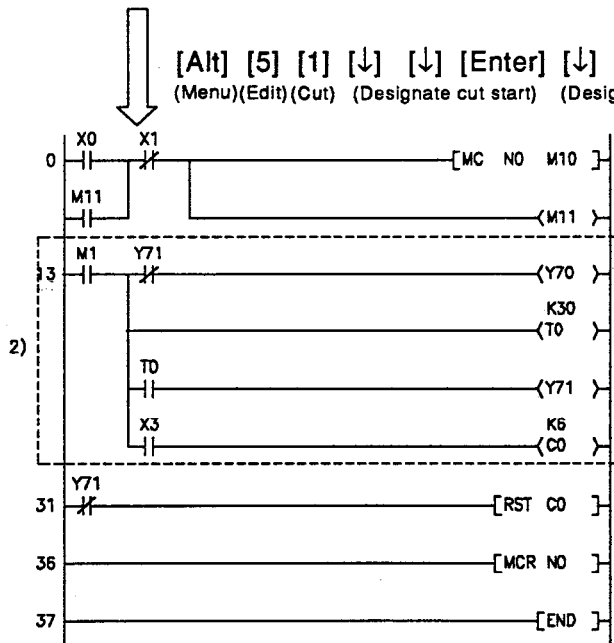

(1)

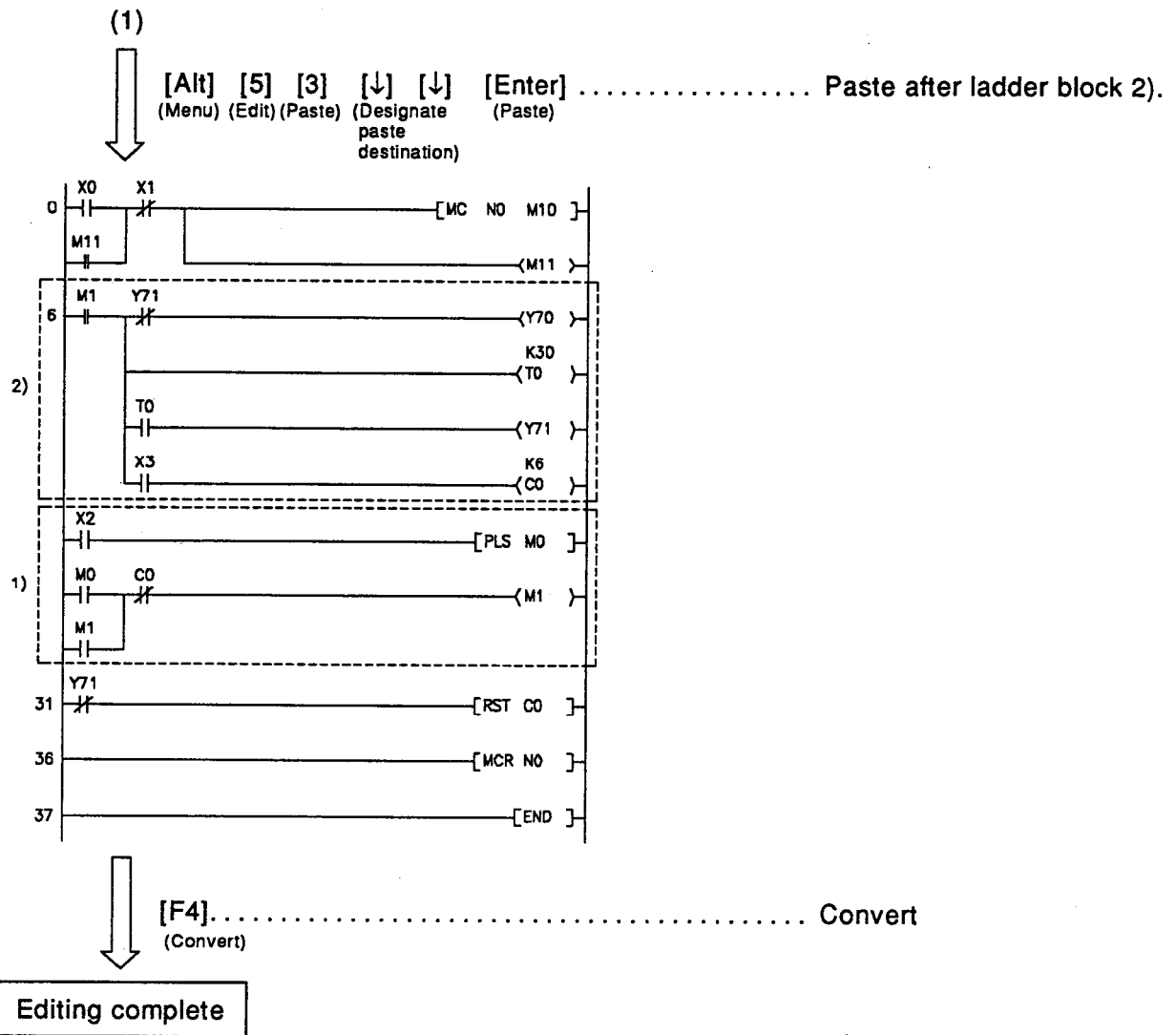

COMMENT

Press [F10] (Undo) key in the ladder write (insert/overwrite) mode during a cut or paste operation to revert to the previous status (to change the cut or paste destination). Only the previous operation can be undone. The undo operation is not possible after conversion. No undo function is available for cut and paste operations on units of ladder blocks in the ladder read mode.

3.5 Operating the CPU for Monitoring and Testing

After setting the switches and internal clock, the program created in Section 3.4.2 is written to the CPU and the CPU is operated to monitor and test the program.

3.5.1 Preparations for operating the CPU

Connect the connectors and set the switches (1) to (3) in the diagram below.

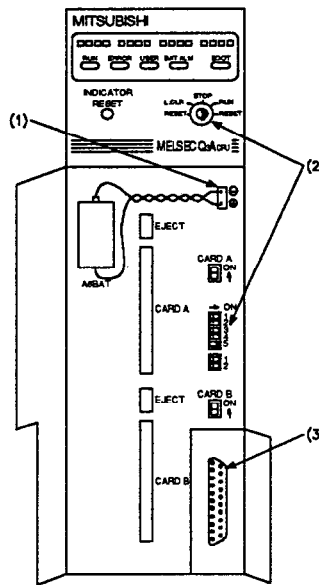

(1) Connect the battery

The battery is unconnected when the CPU is shipped from the factory. Connect the battery, ensuring that the polarity (positive and negative) is correct.

(2) Set the switches

The system setting DIP switches and the RUN/STOP key switch have to be set.

(a) Setting the system setting DIP switches

Set DIP switch #4 to the OFF position.

DIP switch #4 disables writing to the CPU and control instructions.
It must be set OFF to remove this protection.
All other DIP switches can be in either position.

(b) Setting the RUN/STOP key switch

Set to the STOP position.

(3) Connect the RS-422 cable

Connect the cable to the RS-232C/RS-422 converter connected to the IBM PC/AT RS-422 connector.

3. OPERATING PROCEDURE USING THE QnACPU

(4) Set the QnACPU internal clock

Set the QnACPU internal clock to the current time using operations from the mode select screen.

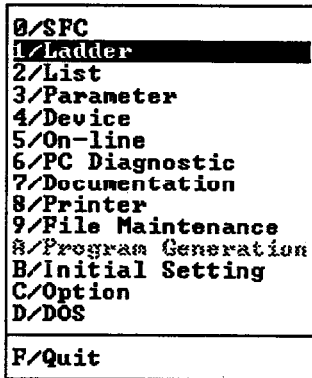

"Mode Select screen"

[6] Select "PC Diagnostic"

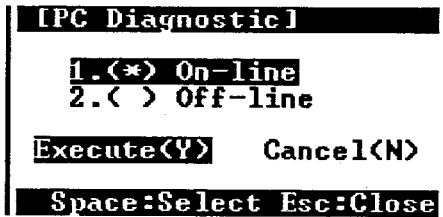

[Y] Execute

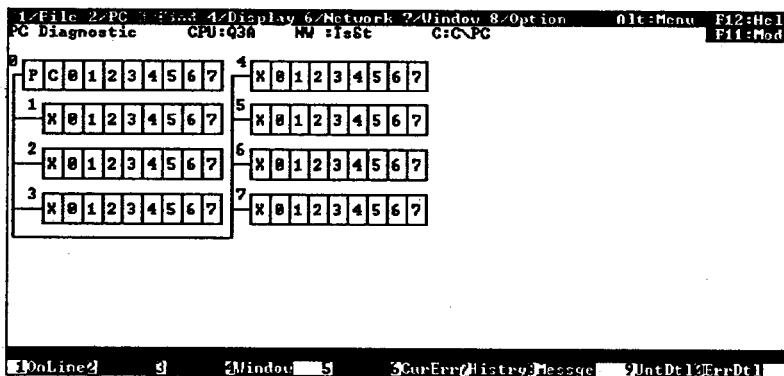

"PC Diagnostic screen"

1)

1)

[Alt] Menu

[2] Select "PC"

```

1/Read...
2/Write...
3/Compare...
4/New...
5/File List...

6/Connection Setting...
7/Remote Operation...

8/Clear Fault History
9/Time Setting
A/Connect Unit
    
```

"PC communications screen"

[9] Select "Time Setting"

```

[Time Setting]
-----
1. Date      Input      Current
             [96-04-27]  96-04-27
2. Time      [13:15:00]  12:08:11

3. Station to Execute
   1.<*) Current Station
   2.< > All Stations
   3.< > Specified Group [ ]

Execute<Y>   Cancel<N>

-----
Esc:Close
    
```

"Time Setting screen"

Setting the date

[SP] [9] [6] [-] [0] [4] [-] [2] [7] [Enter]

Setting the time

[SP] [1] [3] [Shift] + [:] [1] [5] [Shift] + [:] [0] [0] [Enter]

Set the time and date for the current designated station (connected PC).

[SP] [(1)] [Y]

(5) Format QnACPU internal RAM

Format the QnACPU internal RAM using operations from the mode select screen.

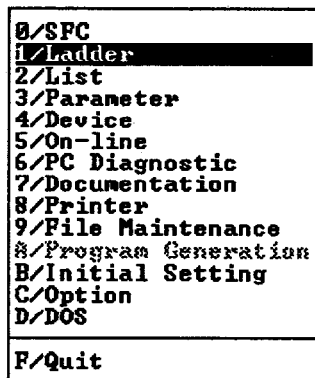

"Mode Select screen"

[5] Select "Online"

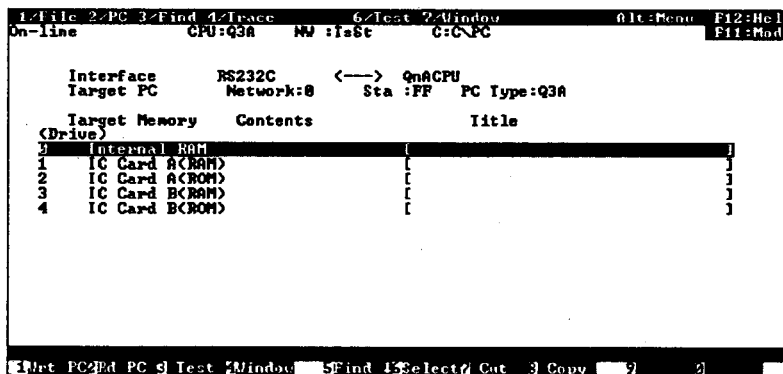

"Online memory select screen"

[Alt] Menu

[2] Select "PC"

1)

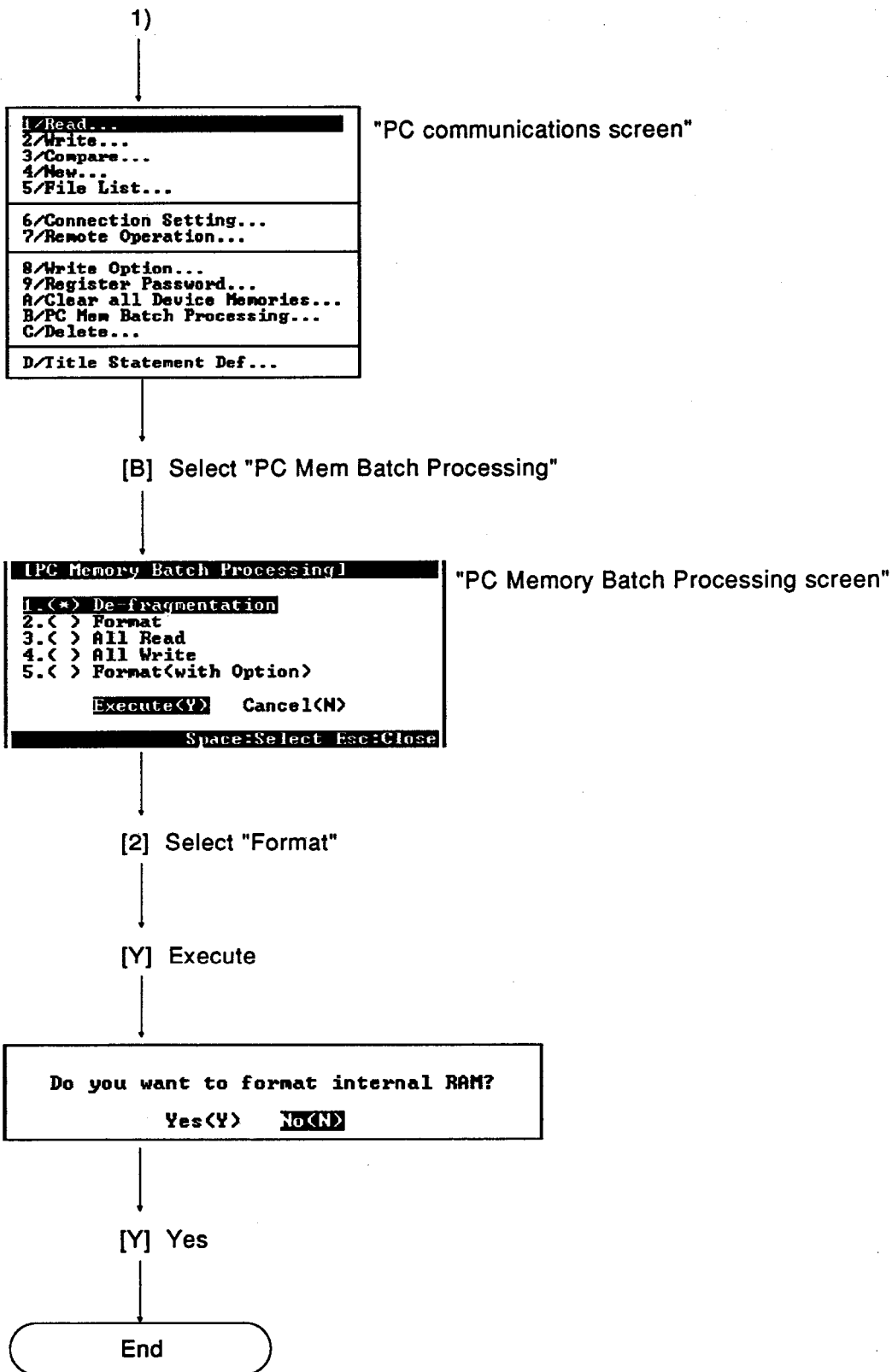

(6) Clear the QnACPU latch devices

Clear the QnACPU latch devices using operations from the mode select screen.

```
0/SFC
1/Ladder
2/List
3/Parameter
4/Device
5/On-line
6/PC Diagnostic
7/Documentation
8/Printer
9/File Maintenance
A/Program Generation
B/Initial Setting
C/Option
D/DOS
F/Quit
```

"Mode Select screen"

[5] Select "Online"

```
1/File 2/PC 3/Find 4/Trace 6/Test 7/Window Alt:Menu F12:Help
On-line CPU:Q3A NW :TsSt C:C:PC F11:Mode

Interface RS232C <---> QnACPU
Target PC Network:0 Sta :FF PC Type:Q3A

Target Memory Contents Title
(Drive)
0 Internal RAM [ ]
1 IC Card A(CRAM) [ ]
2 IC Card A(CRAM) [ ]
3 IC Card B(CRAM) [ ]
4 IC Card B(CRAM) [ ]

F1:Print PC2:Rd PC 3:Test 4:Window 5:Find 6:Select 7:Cut 8:Copy 9: 0
```

"Online memory select screen"

[Alt] Menu

[2] Select "PC"

1)

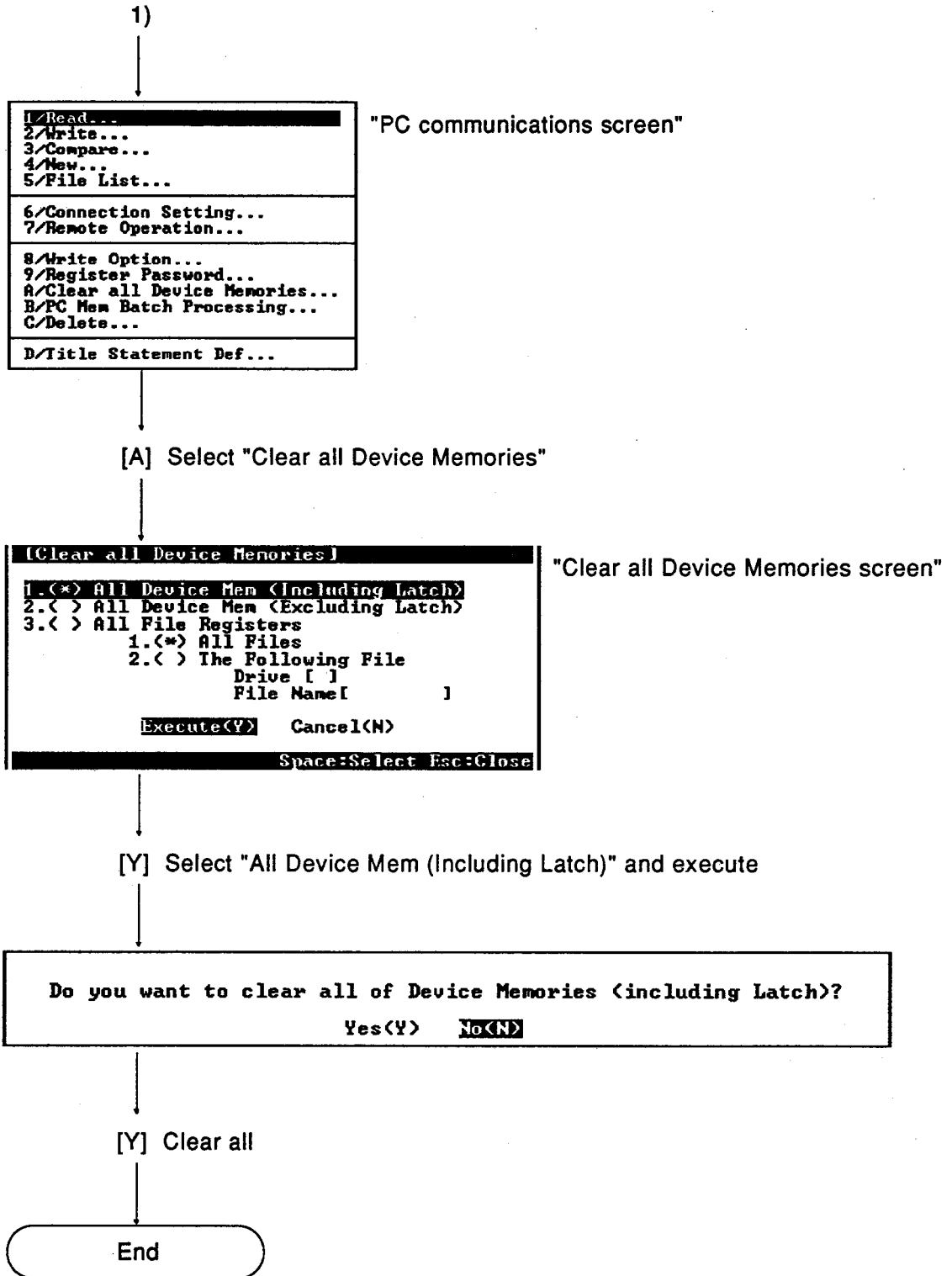

(7) Clear the QnACPU fault history

Clear the fault history data in the QnACPU internal RAM memory using operations from the mode select screen.

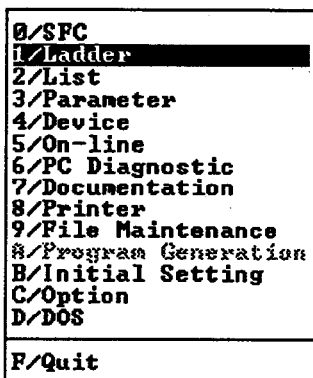

"Mode Select screen"

[6] Select "PC Diagnostic"

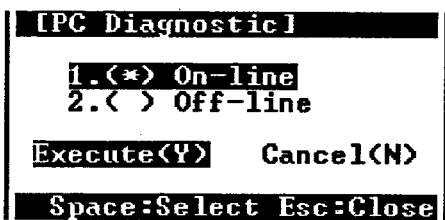

[Y] Execute

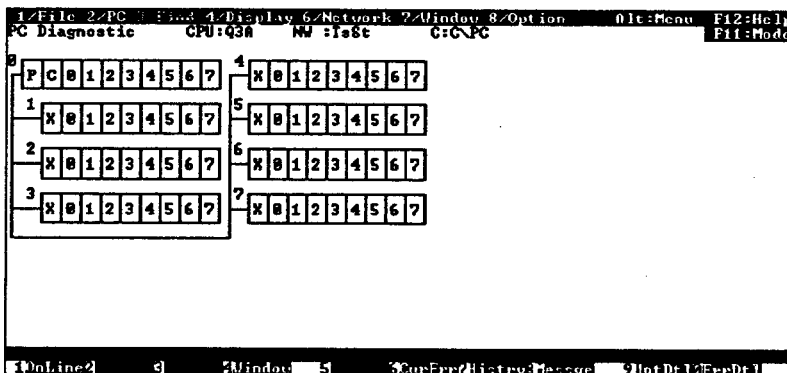

"PC Diagnostic screen"

1)

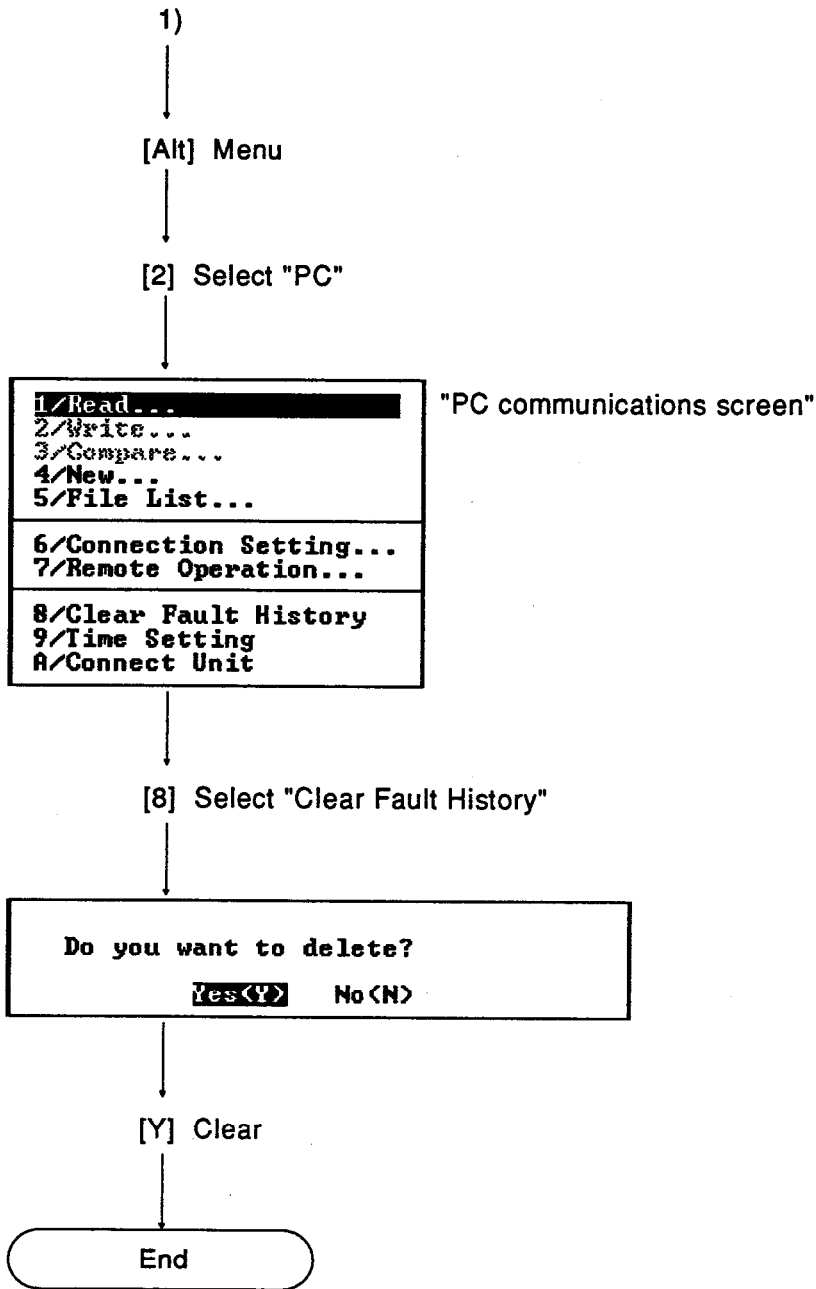

3.5.2 Writing program to CPU

Write the program created in Section 3.4.2 plus the comments created in Section 3.4.3 to the QnACPU using operations from the mode select screen.

Set the QnACPU RUN/STOP key switch to the STOP position.

```

0/SFC
1/Ladder
2/List
3/Parameter
4/Device
5/On-line
6/PC Diagnostic
7/Documentation
8/Printer
9/File Maintenance
A/Program Generation
B/Initial Setting
C/Option
D/DOS
F/Quit
    
```

"Mode Select screen"

[5] Select "On-line"

```

1/File 2/PC 3/Find 4/Trace      6/Test 7/Window      Alt:Menu  F12:Help
On-line      CPU:Q3A  HW :IsSt  G:G\PC      F11:Mode

Interface    RS232C    <--->  QnACPU
Target PC    Network:0  Sta :FF  PC Type:Q3A

Target Memory  Contents      Title
( Drive )
0 Internal RAM
1 IC Card A(RAM)
2 IC Card A(ROM)
3 IC Card B(RAM)
4 IC Card B(ROM)
    
```

"On-line memory select screen"

[0] Select "Internal RAM"

1)

1)

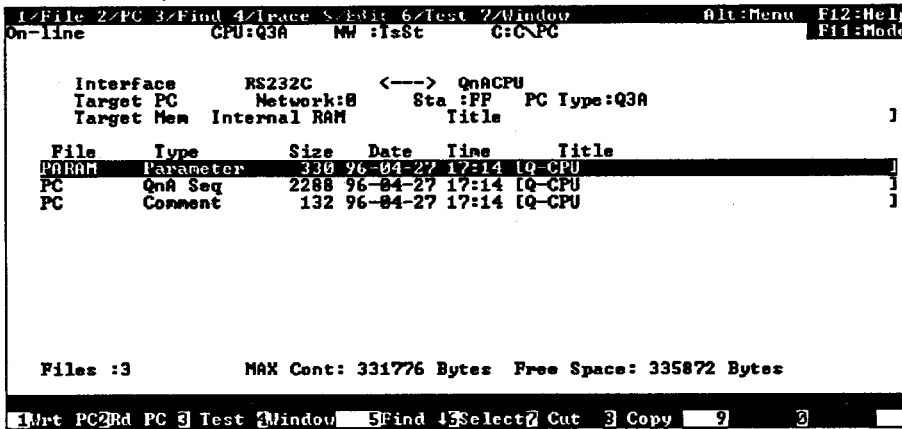

"On-line screen"

[F1] Write PC

The 'Write to PC' dialog box contains the following information:

```

[Write to PC]
Interface RS232C <---> QnACPU
Target PC Network : 8 Station : FF PC Type : Q3A
Target Mem Internal RAM Title [ ]
1. File 1. File Name [PC ] Title [ ]
   2. Tgt 2. [*] Seq/SFC Prog 1.<(*) Whole Range [ ] 1X Step
   3. [*] Device Comment 2.<(*) Step Range [ ] 1- [ ]
   4. [ ] Dev Init Value 3.<(*) Step Range P [ ] - [ ]
   5. [ ] Simulation Data 4.<(*) Block Range [ ] - [ ]
   6. [ ] File Register 1.<(*) Whole Range
   2. Device Mem 1. [ ] Internal 2.<(*) Specify ZR [ ] 1- [ ]
   1.<(*) Whole Range
   2.<(*) Specify Detail Range

Execute<Y> Cancel<N>

Ctrl+L:List Ctrl+D:Dir Space:Select Esc:Close
    
```

"Write to PC screen"

- Write destination is internal RAM.
- The PC selected with "Create..." is automatically displayed as the file name.

- The default values are automatically set for the write data parameters and sequence program (Whole Range).
- Add device comments as write data and write them to the QnACPU.
[SP] [↓] [SP] [3] [Y]

A message is displayed in the message field during writing to the PC and another message indicates when the write operation is complete.

Return to the online memory select screen

POINT

The QnACPU will not run when the key switch is set to the RUN position immediately after a new program is written to the QnACPU. The program is first checked and a message is displayed, as follows:

Q2A(-S1) RUN LED flashes
 Q3A, Q4A "PRG.CHECK!!" displayed
 First set to RESET, then to RUN.

3.5.3 Operating the CPU for monitoring

Read the program (written in Section 3.5.2) from the QnACPU before operating and monitoring the QnACPU.

- (1) Read the program from the QnACPU using operations from the online memory select screen.

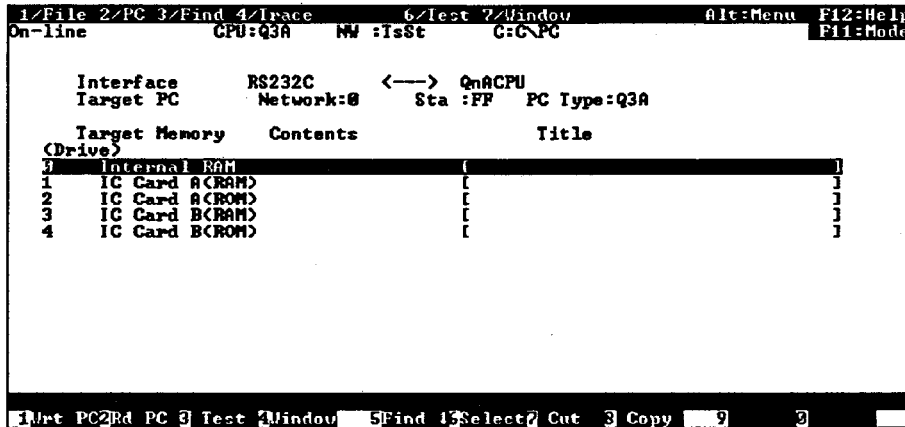

"On-line memory select screen"

[0] Select "Internal RAM"

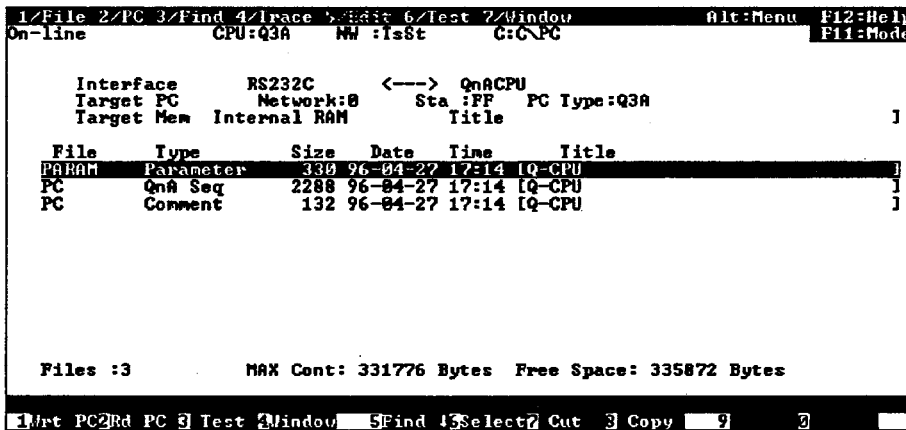

"On-line screen"

Check the file name and data type.

[F2] Read PC

1)

1)

"Read from PC screen"

Setting the file name as "PC".
 [SP] [SP] [P] [C]

Read program from QnACPU, excluding device initial values and file register data.
 [Tab] [Tab] [SP] [4] [5] [Y]

A message is displayed in the message field during reading from the PC and another message indicates when the read operation from QnACPU is complete.

Return to the online memory select screen

3. OPERATING PROCEDURE USING THE QnACPU

MELSEC-QnA

- (2) Monitor QnACPU using ladder monitor operations from the mode select screen.

Set the QnACPU RUN/STOP key switch to the RUN position.

```

0/SFC
1/Ladder
2/List
3/Parameter
4/Device
5/On-line
6/PC Diagnostic
7/Documentation
8/Printer
9/File Maintenance
8/Program Generation
B/Initial Setting
C/Option
D/DOS
-----
F/Quit
    
```

"Mode Select screen"

[1] Select "Ladder"

[F3] Monitor

```

1/ File 2/ PC 3/ Find 4/ Disp 5/ Edit 6/ Monitor 7/ Window 8/ Option Alt: Menu F12: Help
Ld Monitor CPU: Q3A 72Step C: C:\PC <Ins> F11: Mode
0 X0 X1 DMC N0 M10
  M11
  M10 = M10
6 X2 IPLS M0 1
  M0 C0 M1
9 M1 Y71 <Y70 >
  M1 K30 <K30 >
13
-----
10
0
30
<Scan 8ms> <Interval 116ms> <Status RUN > <Target CPU * >
Executing...
1 Write 2 Read 3 Mon 4 Cause 5 6 7 8 9 10 11 12 13 14 15 16 17 18 19 20 21 22 23 24 25 26 27 28 29 30 31 32 33 34 35 36 37 38 39 40 41 42 43 44 45 46 47 48 49 50 51 52 53 54 55 56 57 58 59 60 61 62 63 64 65 66 67 68 69 70 71 72 73 74 75 76 77 78 79 80 81 82 83 84 85 86 87 88 89 90 91 92 93 94 95 96 97 98 99 100 101 102 103 104 105 106 107 108 109 110 111 112 113 114 115 116 117 118 119 120 121 122 123 124 125 126 127 128 129 130 131 132 133 134 135 136 137 138 139 140 141 142 143 144 145 146 147 148 149 150 151 152 153 154 155 156 157 158 159 160 161 162 163 164 165 166 167 168 169 170 171 172 173 174 175 176 177 178 179 180 181 182 183 184 185 186 187 188 189 190 191 192 193 194 195 196 197 198 199 200 201 202 203 204 205 206 207 208 209 210 211 212 213 214 215 216 217 218 219 220 221 222 223 224 225 226 227 228 229 230 231 232 233 234 235 236 237 238 239 240 241 242 243 244 245 246 247 248 249 250 251 252 253 254 255 256 257 258 259 260 261 262 263 264 265 266 267 268 269 270 271 272 273 274 275 276 277 278 279 280 281 282 283 284 285 286 287 288 289 290 291 292 293 294 295 296 297 298 299 300 301 302 303 304 305 306 307 308 309 310 311 312 313 314 315 316 317 318 319 320 321 322 323 324 325 326 327 328 329 330 331 332 333 334 335 336 337 338 339 340 341 342 343 344 345 346 347 348 349 350 351 352 353 354 355 356 357 358 359 360 361 362 363 364 365 366 367 368 369 370 371 372 373 374 375 376 377 378 379 380 381 382 383 384 385 386 387 388 389 390 391 392 393 394 395 396 397 398 399 400 401 402 403 404 405 406 407 408 409 410 411 412 413 414 415 416 417 418 419 420 421 422 423 424 425 426 427 428 429 430 431 432 433 434 435 436 437 438 439 440 441 442 443 444 445 446 447 448 449 450 451 452 453 454 455 456 457 458 459 460 461 462 463 464 465 466 467 468 469 470 471 472 473 474 475 476 477 478 479 480 481 482 483 484 485 486 487 488 489 490 491 492 493 494 495 496 497 498 499 500 501 502 503 504 505 506 507 508 509 510 511 512 513 514 515 516 517 518 519 520 521 522 523 524 525 526 527 528 529 530 531 532 533 534 535 536 537 538 539 540 541 542 543 544 545 546 547 548 549 550 551 552 553 554 555 556 557 558 559 560 561 562 563 564 565 566 567 568 569 570 571 572 573 574 575 576 577 578 579 580 581 582 583 584 585 586 587 588 589 590 591 592 593 594 595 596 597 598 599 600 601 602 603 604 605 606 607 608 609 610 611 612 613 614 615 616 617 618 619 620 621 622 623 624 625 626 627 628 629 630 631 632 633 634 635 636 637 638 639 640 641 642 643 644 645 646 647 648 649 650 651 652 653 654 655 656 657 658 659 660 661 662 663 664 665 666 667 668 669 670 671 672 673 674 675 676 677 678 679 680 681 682 683 684 685 686 687 688 689 690 691 692 693 694 695 696 697 698 699 700 701 702 703 704 705 706 707 708 709 710 711 712 713 714 715 716 717 718 719 720 721 722 723 724 725 726 727 728 729 730 731 732 733 734 735 736 737 738 739 740 741 742 743 744 745 746 747 748 749 750 751 752 753 754 755 756 757 758 759 760 761 762 763 764 765 766 767 768 769 770 771 772 773 774 775 776 777 778 779 780 781 782 783 784 785 786 787 788 789 790 791 792 793 794 795 796 797 798 799 800 801 802 803 804 805 806 807 808 809 810 811 812 813 814 815 816 817 818 819 820 821 822 823 824 825 826 827 828 829 830 831 832 833 834 835 836 837 838 839 840 841 842 843 844 845 846 847 848 849 850 851 852 853 854 855 856 857 858 859 860 861 862 863 864 865 866 867 868 869 870 871 872 873 874 875 876 877 878 879 880 881 882 883 884 885 886 887 888 889 890 891 892 893 894 895 896 897 898 899 900 901 902 903 904 905 906 907 908 909 910 911 912 913 914 915 916 917 918 919 920 921 922 923 924 925 926 927 928 929 930 931 932 933 934 935 936 937 938 939 940 941 942 943 944 945 946 947 948 949 950 951 952 953 954 955 956 957 958 959 960 961 962 963 964 965 966 967 968 969 970 971 972 973 974 975 976 977 978 979 980 981 982 983 984 985 986 987 988 989 990 991 992 993 994 995 996 997 998 999 1000
    
```

"Ladder Monitor screen"

POINT

Use the registered device monitor to monitor the contents of a word device which is not displayed on the ladder monitor screen. The example below monitors the counter C0.

Registered device monitor: [F9] [SP] [C] [0] [Enter] [SP] ([1]) [Y]
 (Registration) (Counter C0) (16-bit)

Actual System Operation

Watch the ladder monitor screen and confirm the following operations.

- 1) Turn ON X0 to enable the master control program (from MC to MCR) and permit actual system operation. (enable conveyor operation)
- 2) Y70 (buzzer) lights for 3 seconds after X2 (workpiece sensor) turns ON, then Y71 lights (start conveyor).
- 3) After X3 is turned from OFF to ON six times (6 products moved to workpiece), Y71 goes out (stop conveyor). X2 (no workpiece detected) turns OFF.
- 4) Repeat steps 2) and 3) (equivalent to cycle operation).
- 5) Press X1 to disable the master control program (from MC to MCR) and end actual system operation. (stop conveyor operation)
Operation cannot be restarted after X1 is pressed during operation.
Repeat the operations from step 1) (enable conveyor operation).

3.5.4 Modifying program while monitoring CPU operation (online program change (write during RUN))

Use online program change (write during RUN) to modify a program written to the QnACPU.

As an example, the timer T0 set value K30 (3 seconds) is changed to K60 (6 seconds).

Before modifying the program, set the "Write & Conv Setting...".

- (1) Set the "Write & Conv Setting..." to "Write into PC during RUN state". Operations from ladder monitor screen (similar to Section 3.5.3 (2)).

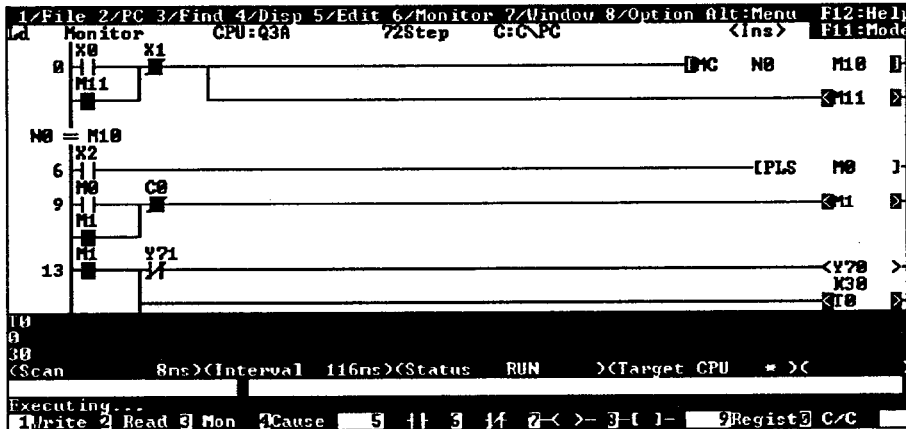

"Ladder Monitor screen"

[Alt] Menu

[8] Select "Options"

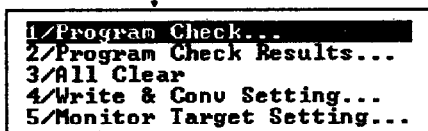

[4] Select "Writing & Conv Setting..."

1)

1)

[Write & Conversion Setting]	
1. Align Left after Conversion	1.< > Yes 2.<*) No
2. Check Double Coil at Writing	1.< > Yes 2.<*) No
3. Device Cmt Inp at Writing Ins	1.< > Continue 2.<*) Pause
4. Write During Run Setting	1.<*) Write into PC during Run state. 2.< > Write into PC in Stop state. 3.< > Don't Write into PC.
5. Monitor in Write Mode	1.< > Yes 2.<*) No
6. Write Target Setting	1.< > 1 Ladder Block 2.<*) Displayed Screen
7. Write Method at Write During Run	1.<*) Normal 2.< > Relatively using Pointer
8. Disp MC on Left-side Power Rail	1.< > Yes 2.<*) No
Execute(Y) Cancel(N)	
Space>Select Esc:Close	

"Write & Conversion Setting screen"

Set "Write into PC during Run state."
[4] [1] [Y]... Revert to ladder monitor screen.

(2) Modify program
Use the following operations to modify the program.

(a) [F1] [Insert]... Set the ladder monitor screen to the write (Write) (Overwrite) (overwrite) mode.

(b) Press the cursor keys to move the cursor immediately in front of

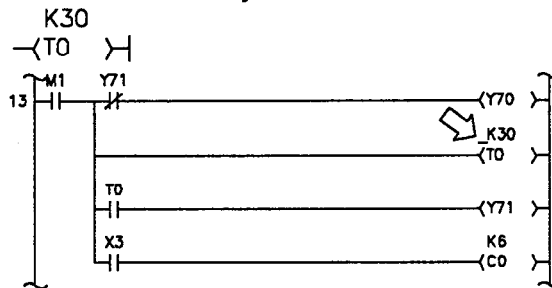

[T] [0] [SP] [K] [6] [0] [Enter]... Modify the timer T0 set value.

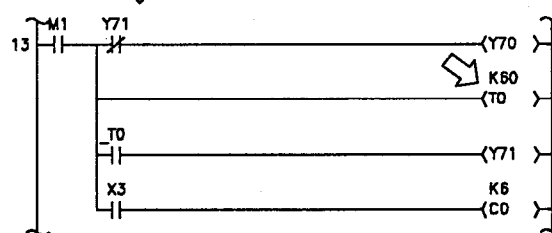

(c) Press [F4] key to convert the program.
(Convert)

A message is displayed in the message field during conversion. Another message indicates that the operation is complete and the step number was changed "Write into PC during RUN state." ends.

(3) Check actual system operation
Follow step (2) described in Section 3.5.3 (2) "Actual System Operation" to check that the time Y70 lights has changed from 3 seconds to 6 seconds.

3.5.5 Registering a password

A password can be registered to protect access to the programs in the QnACPU. It can inhibit reading, writing, and display or be used to write protect the programs so that they cannot be accidentally overwritten. Operation from the mode select screen.

```

0/SFC
1/Ladder
2/List
3/Parameter
4/Device
5/On-line
6/PC Diagnostic
7/Documentation
8/Printer
9/File Maintenance
A/Program Generation
B/Initial Setting
C/Option
D/DOS
F/Quit
    
```

"Mode Select screen"

[5] Select "On-line"

```

1/File 2/PC 3/Find 4/Trace          6/Test 7/Window          Alt=Menu  F12=Help
On-line          CPU:Q3A      NW :TsSt      C:GnPC          F11=Mode

Interface      RS232C      <---> QnACPU
Target PC      Network:8   Sta :FF    PC Type:Q3A

Target Memory  Contents    Title
(Drive)
0 Internal RAM  [           ]
1 IC Card A(RAM) [           ]
2 IC Card A(ROM) [           ]
3 IC Card B(RAM) [           ]
4 IC Card B(ROM) [           ]
    
```

"Online Memory Select screen"

[Alt] Menu

[2] Select "PC"

1)

1)

```

1/Read...
2/Write...
3/Compare...
4/New...
5/File List...

6/Connection Setting...
7/Remote Operation...

8/Write Option...
9/Register Password...
A/Clear all Device Memories...
B/PC Mem Batch Processing...
C/Delete...

D/Title Statement Def...
    
```

"PC Communications screen"

[9] Select "Register Password"

```

[Register Password]
Current
1. Password [      ]
                New
2. Operation 1.(*) Change [123456]
                1.<*) Read, Write and Display Protect
                2.< > Write Protect
                2.< > Cancel Password
                3.< > None
                4.< > Change Attribute

3. Memory 1.[*] Internal RAM
   2.[ ] IC Memory Card A<RAM>
   3.[ ] IC Memory Card A<ROM>
   4.[ ] IC Memory Card B<RAM>
   5.[ ] IC Memory Card B<ROM>

Execute<Y>   Cancel<N>
Space>Select Esc:Close
    
```

"Register Password screen"

The password can be designated as up to 6 alphanumeric characters.

Stop the QnACPU

Register the password "123456" in the QnACPU to inhibit reading, writing, and display (default) for the internal RAM memory (default).

[2] [1] [2] [3] [4] [5] [6] [↓] [Y]

(New) (Password: 123456) (Read, Write and (Execute)
Display Protect)

A message is displayed in the message field when the registration operation is complete.

POINTS

- (1) Check the password operation after temporarily quitting the IBM PC/AT GPP functions. They password does not become effective until the GPP functions are quit.
- (2) Follow the procedures below to initially set the password to access a QnACPU for which an password has been set.
Repeat the operations on the previous page to display the register password screen.

```

[Register Password]
Current
1. Password [123456]
2. Operation 1.< > Change [ New ]
      1.<=> Read,Write and Display Protect
      2.< > Write Protect
      2.< > Cancel Password
      3.<=> None
      4.< > Change Attribute
3. Memory 1.[*] Internal RAM
      2.[ ] IC Memory Card A<RAM>
      3.[ ] IC Memory Card A<ROM>
      4.[ ] IC Memory Card B<RAM>
      5.[ ] IC Memory Card B<ROM>
Execute<Y> Cancel<N>
Space:Select Esc:Close
    
```

"Register Password screen"

Set the password and select "None"

```

[1] [1] [2] [3] [4] [5] [6]
(Current) (Registered password: 123456)
[↓] [SP] [↓] [↓] [↓] [↓] [SP] [Y]
(Operation) (Move cursor to "None") (Select) (Execute)
    
```

A message is displayed in the message field when the operation is complete.

If the password is incorrect, a message indicates that the file cannot be accessed and file access is not permitted.

- (3) If the password is completely forgotten, the PC memory must be formatted, by the method described below.

[Set the QnACPU to STOP.]

```

[PC communications screen]
=> [B] [2] [Y] [Do you want to format internal RAM?] [Y]
(Batch operation)(Format) (Execute) (Yes)
    
```

A message is displayed in the message field when the formatting of the QnACPU internal RAM is complete (the memory contents have been cleared).

3.5.6 Checking responses to forced faults (PC diagnosis)

The output module is forcibly removed during QnACPU operation to simulate the AY42 (64-point) output module falling out of the PC CPU system in Section 3.1.

- (1) Check QnACPU error indicator flashing and error message display

Check that the error indicator flashes and that the following message appears in the message display window:

Display message: UNIT VERIFY ERR.

- (2) Determine cause using PC diagnosis

Follow the procedure below to determine the cause of the error with PC diagnosis using operations from the mode select screen.

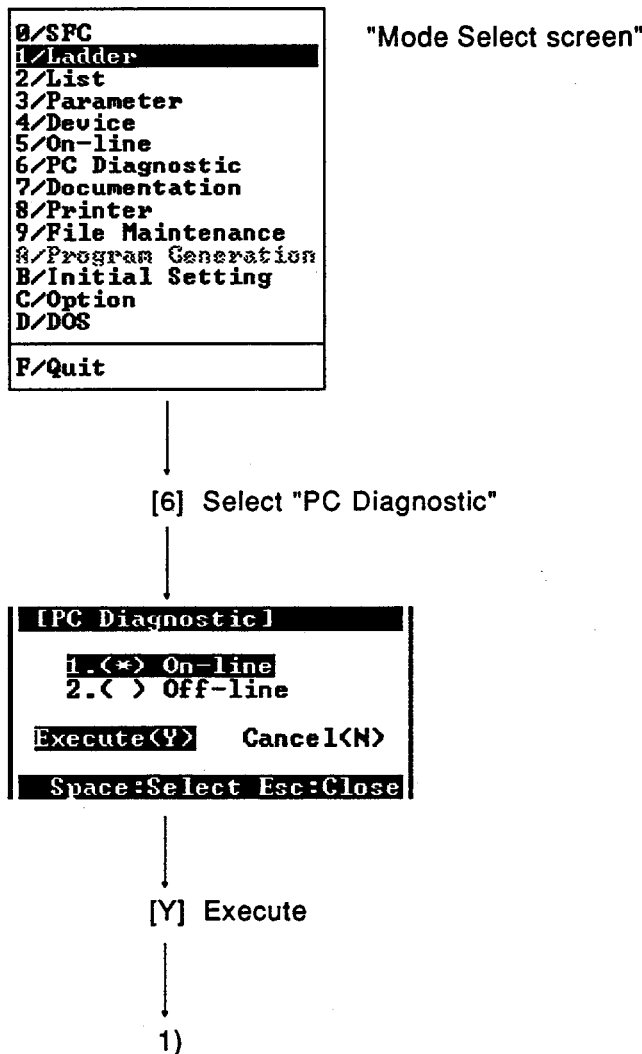

1)

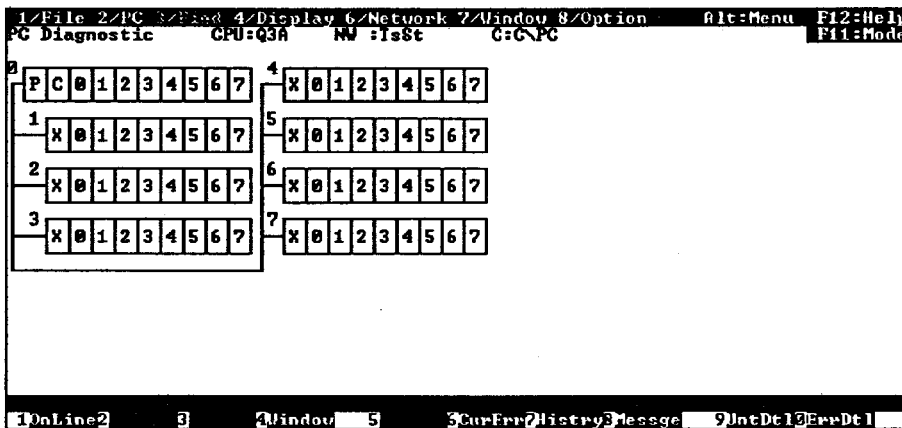

"PC Diagnostic screen"

[Alt] Menu

[4] Select "Dispyay"

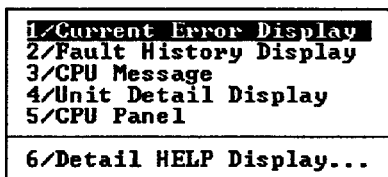

[1] Select "Current Error Display"

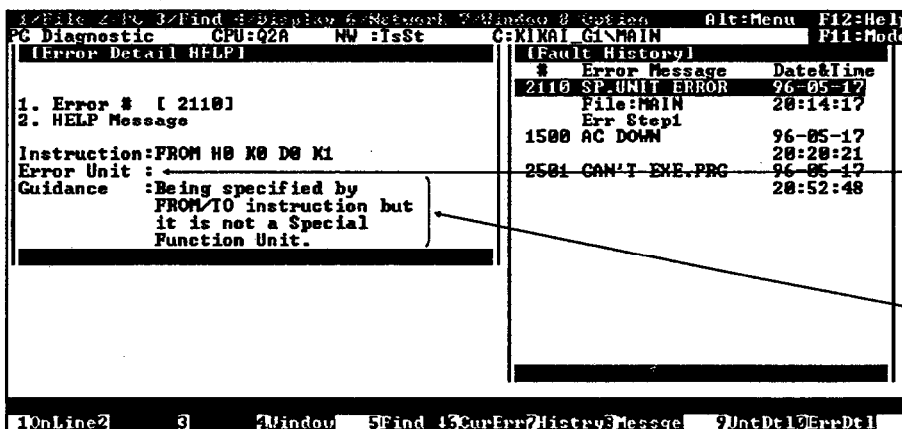

"Current Error Display screen"

Indicates the module in Slot 1 of the base unit.

Cause of error

(3) Checking the module causing the I/O module verification error

The PC diagnosis indicated the cause of the error as "Being specified by FROM/TO instruction but it is not a Special Function Unit." (unit verification error). Next, monitor the following special registers to determine the module causing the error.

Special Register	Name	Function
SD61	I/O module verification error module number	Stores the I/O signal (latest number) of the module where the I/O module verification error occurred.
SD1400 to SD1431	I/O verification table	Stores the I/O module verification error information in 16-bit units as a bit pattern. 0: no error 1: error

Monitor SD61, then SD1400.
Operate from the mode select screen.

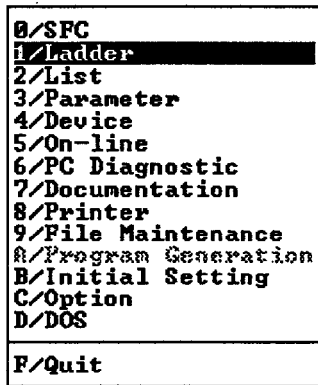

"Mode Select screen"

[1] Select "Ladder"

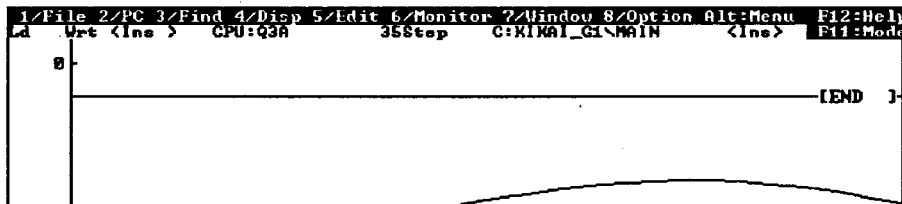

"Ladder Write (insert) screen"

1)

1)

[Alt] Menu

[6] Select "Monitor/Test".

```

1/ Batch monitor...
2/ Multi-Devices Monitor...
3/ ON/OFF Cause...
4/ Measuring Scan Time...

5/ Device Registration...
6/ Monitoring Condition...
7/ Monitor Stop Condition...
8/ Monitor Data Processing...
9/ Device Test...

A/ Trace...
B/ Stop Execution...
C/ Partial Execution...
D/ Perform Skip...
E/ Simulation...

F/ Change Monitor Field Format
G/ Program List Monitor
    
```

"Monitor/Test Select screen"

[1] Select "Batch monitor"

```

[Batch Monitor]

1. Device [SD61]
2. Display Form 1.<*> Bit & Word
                 2.<> Bit Multi Points
                 3.<> Word Multi Point
                 4.<> I/C Multi-Points

Execute<Y> Cancel<N>

Space:Select Esc:Close
    
```

"Batch Monitor Device Setting screen"

Set special register SD61.
 The display format is bit & word monitor (default).
 [SP] [S] [D] [6] [1] [Enter]
 (Select) (Monitor device SD61)

[Y] Execute

2)

2)

Monitoring SD61

Device SD61

Device	0	1	2	3	4	5	6	7	8	9	A	B	C	D	E	F
SD61						■										
SD62																
SD63																
SD64																
SD65																
SD66																
SD67																
SD68																
SD69																
SD70																
SD71																
SD72																

Executing... 1 Device 2 3 Mon 4 5 Force 1 3 Force 1 2 10/16 32Bit 9 9

"Bit & Word Device Monitor screen"

Press [F7] key to select the hexadecimal display.

Indicates that the I/O number (latest number) of the module where verification error occurred was X, Y40. (Corresponds to AY42 mounted in Slot 1.)

[F1] Device

"Monitor Device Setting screen"

1. Monitor Device [SD1400] 1

Execute<Y> Cancel<N>

Esc=Close

Set the next monitor device SD1400.
[BS] [BS] [1] [4] [0] [0] [Enter]

(Previous device No. is cleared.)

[Y] Execute

Monitoring SD1400

Device SD1400

Device	0	1	2	3	4	5	6	7	8	9	A	B	C	D	E	F
SD1400					■	■	■	■								
SD1401																
SD1402																
SD1403																
SD1404																
SD1405																
SD1406																
SD1407																
SD1408																
SD1409																
SD1410																
SD1411																

Executing... 1 Device 2 3 Mon 4 5 Force 1 3 Force 1 2 10/16 32Bit 9 9

"Bit & word Device Monitor screen"

Indicates that the I/O module verification error occurred for XY40 to 4F, XY50 to 5F, XY60 to 6F, and XY70 to 7F.

3.6 Printing the Program

Print out the program created in Section 3.4.2 plus the comments, machine names, and contact/coil destinations created in Section 3.4.3 on a PC-PR201H printer.

3.6.1 Setting the printer and paper size

Set the type of printer used and the paper size using operations from the mode select screen.

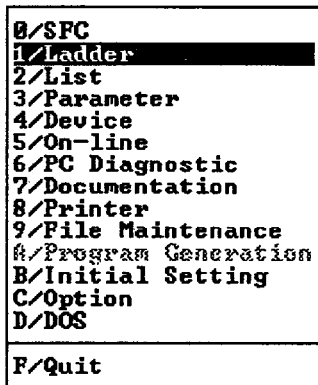

"Mode Select screen"

[8] Select "Printer"

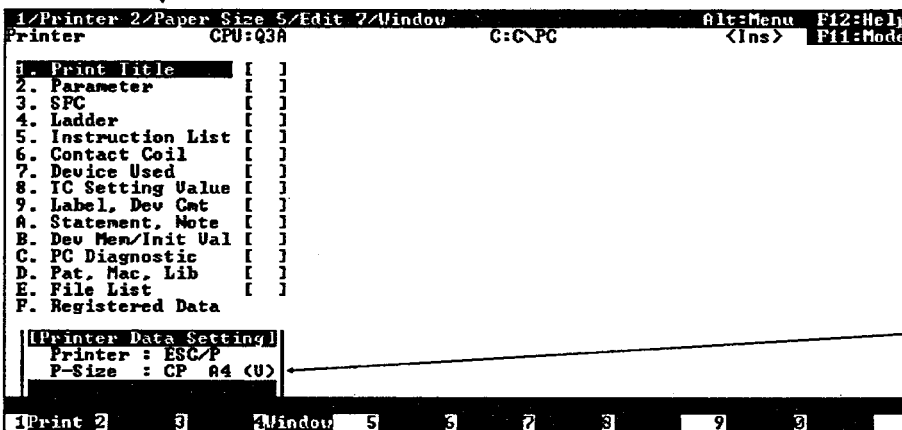

"Printer Mode screen"

Default is cut paper, A4 (V).

[Alt] Menu

[2] Select "Paper size"

1)

1)

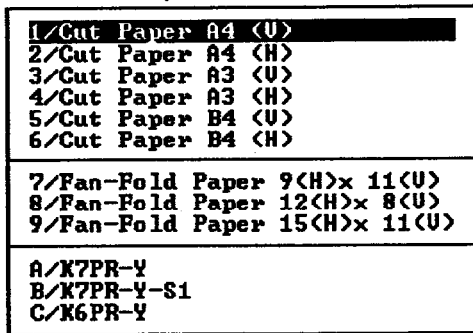

"Paper Size Setting screen"

[7] Select "Fan-Fold Paper, 9 (H) x 11 (V)"

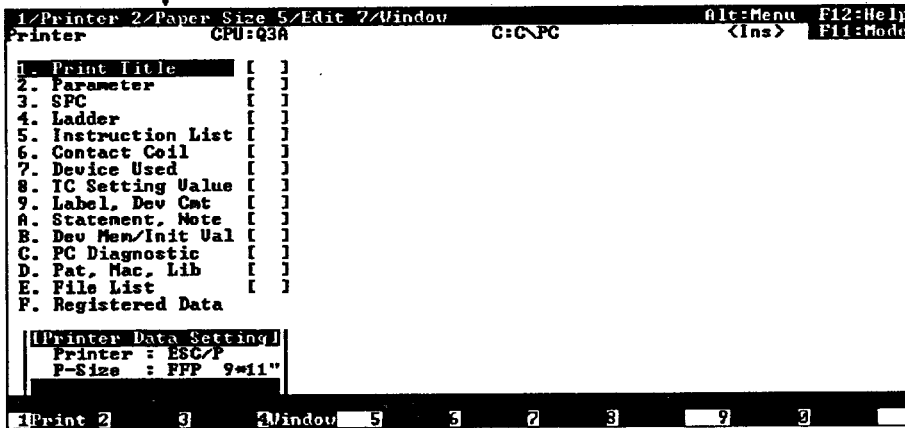

"Printer Mode screen"

3.6.2 Printing out the ladder program

Select "Ladder" as the print item, then set the print format, including printing conditions, printing method, whether headers and footers are added, and the print start position, using operations from the printer mode screen.



"Printer Mode screen"

[↓] ... [↓] [SP] Select "Ladder".
(Press 3 times)

The screenshot shows a terminal window titled 'Ladder Print Setting'. It is divided into three columns of settings. Column 1 (Condition) includes options like 'Skip Blank Line', 'With Device Comment', 'All Characters', 'Display Image', 'With Statement/Note', 'With Device Label', 'With Contact User', and 'With Coil User'. Column 2 (Format) includes 'Standard (9 Contacts)', 'Standard (11 Contacts)', 'Detail (9 Contacts)', 'Detail (11 Contacts)', 'ANK (9 Contacts)', and 'ANK (11 Contacts)'. Column 3 (Step Print Range) includes 'All' and 'Specified'. At the bottom, there are 'Execute (Y)' and 'Cancel (N)' buttons, and a footer 'Space:Select Esc:Close'.

"Ladder Print Setting screen"

Set the condition, format, and step print range.
Set with [SP] or [↑]/[↓] keys.

The default settings are: "Skip Blank Line", "No Device Comment", "No Device Label", "No Contact User", "No Coil User", "Format: Standard (9 Contacts)", and "Step Print Range: A11".

1)

1)

[F1] Print

[Printing]

```

1. Page Type
1.<*) - ** -          Initial[  1]
2.< > ** - **          Initial[  1]-[  1]
3.< > Block # - **     Initial Value Block # -[  1]
4.< > No Printing

2. Header
1.< > Common          4. Print Inter-line Space  6. Left Margin
2.< > Per Item        1.< > Yes                [ 6]Character
3.<*) No              2.<*) No
                    5. Open New Page
3.<*) No              1.<*) Yes                7. Top Margin
                    2.< > No                [ 2]Row

Execute<Y>  Cancel<N>

Space>Select  Esc:Close
            
```

"Printing screen"

Set the print execution conditions. Set the left and top margins only, leaving other items as default values.
 Set left margin.
 [6] [SP] [Enter]. 6 characters
 Set top margin.
 [↓] [SP] [2] [Enter]. . . . 2 rows

The default settings are: "Page Type = -**-", "Header: No", "Footer: No", "Print Inter-line Space: No", "Open New Page: Yes".

[Y] Print

Executes printing.
All right?

Yes<Y> No<N>

[Y] Yes ... Start printing

3.6.3 Sample ladder program print-out

An example of a ladder program print-out is shown below.

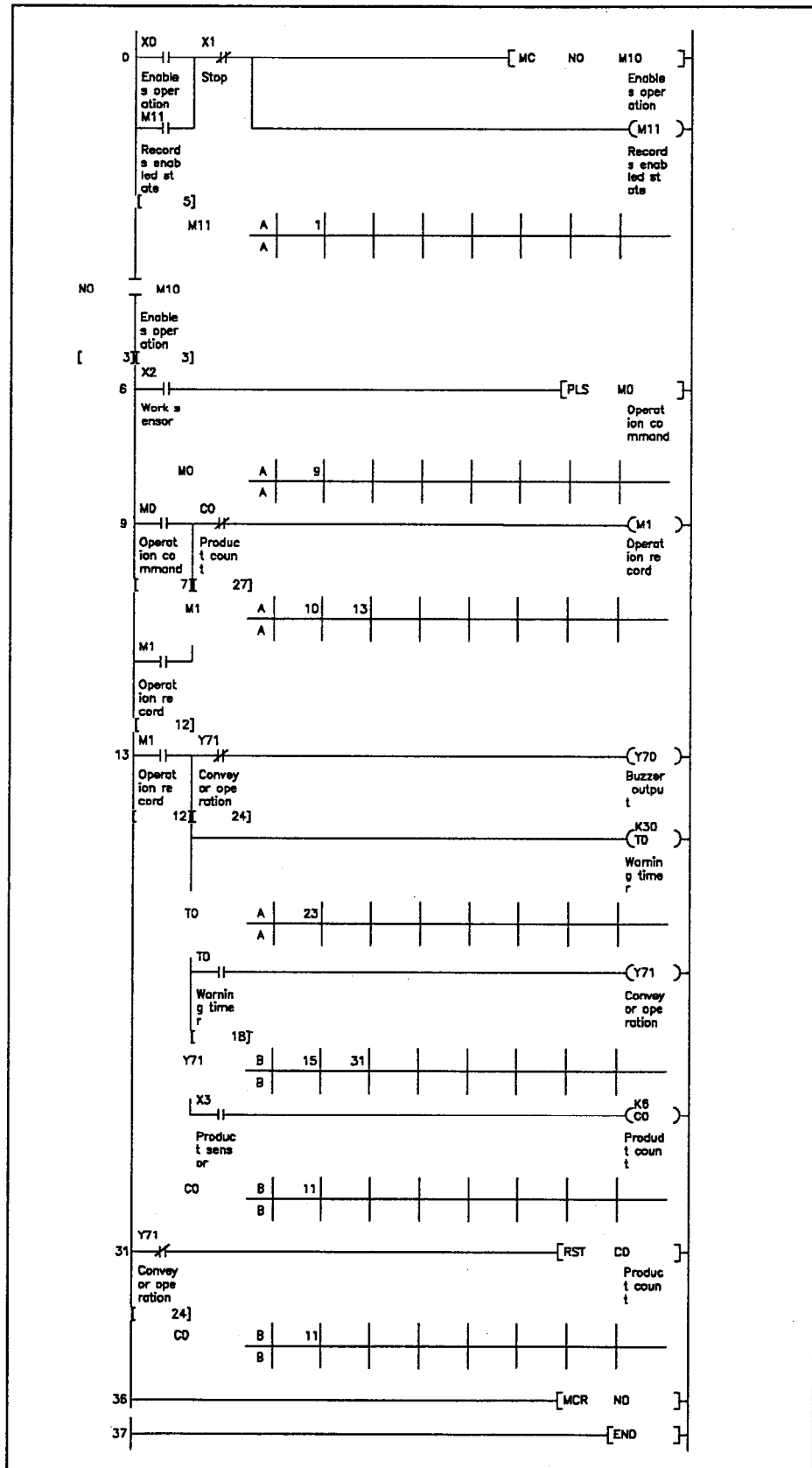

3.7 Quitting GPP Functions

Quite the GPP functions using operations from the model select screen.

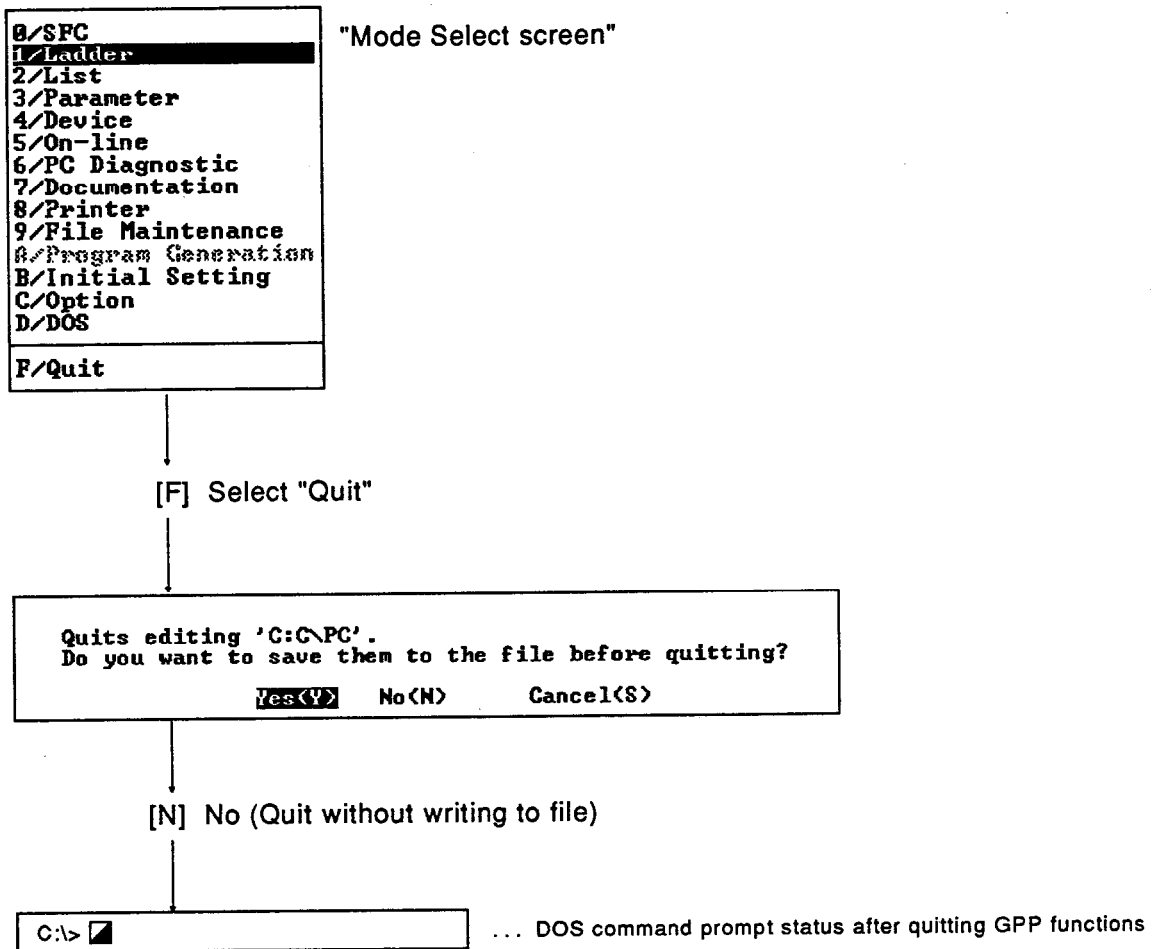

4. MAKING THE MOST OF YOUR QnACPU (1)

MELSEC-QnA

4. MAKING THE MOST OF YOUR QnACPU (1)

This chapter describes methods to make the best use of your QnACPU, which differ from the conventional ACPU operations.

4.1 System Configuration

The system configuration shown below is used for the descriptions in this chapter.

		X00 to X0F	X10 to X1F	Y20 to Y2F	Y30 to Y3F	X/Y40 to X/Y5F	X/Y60 to X/Y7F
A62P	Q3ACPU	AX40	AX40	AY40	AY40	A6BAD	A62DA

Memory card: Q1MEM-512SE

4.2 Programming for Individual Control Processes

The QnACPU handles sequence programs as files, so that sequence programs can be divided up into control processes for program design. This section describes this method of programming.

4.2.1 File structure

- (1) Program execution can be matched to the type of control.

Programs can be selected from four types: initial execution, scan execution, low-speed execution, and standby.

These programs can be set to run when required, thereby reducing the scan time of the permanently executing scan program.

- (a) Initial execution (initial program)

A program executed once only when the QnACPU is set to RUN. Used for initialization.

- (b) Scan execution (scan program)

A permanently executing program.

Equivalent to a conventional program running from step 0 to END.

Can include sub-routine programs and interrupt programs.

- (c) Low-speed execution (low-speed program)

A program which is not entirely executed each scan but which is executed over several scans, using the constant scan surplus time or a set time.

Used for programs run at low frequency, such as scheduled inspection programs.

- (d) Standby (standby program)

A program which is executed when a certain start condition is met, such as a sub-routine program or an interrupt program.

Used when the sub-routine programs and interrupt programs are held as library data and are handled separately to the main program.

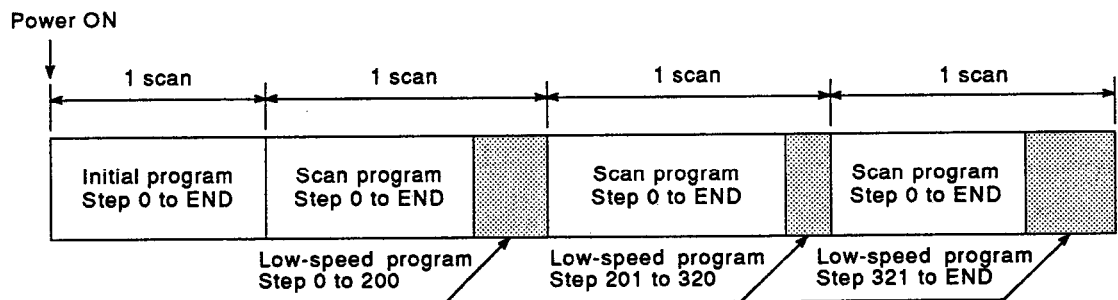

(2) File Management

The sequence program and other data handled by the QnACPU is managed as files. Whereas programs were conventionally handled as main programs and sub-programs, the QnACPU allows structured programming, such that each type of program can be broken down for individual programmers or processes.

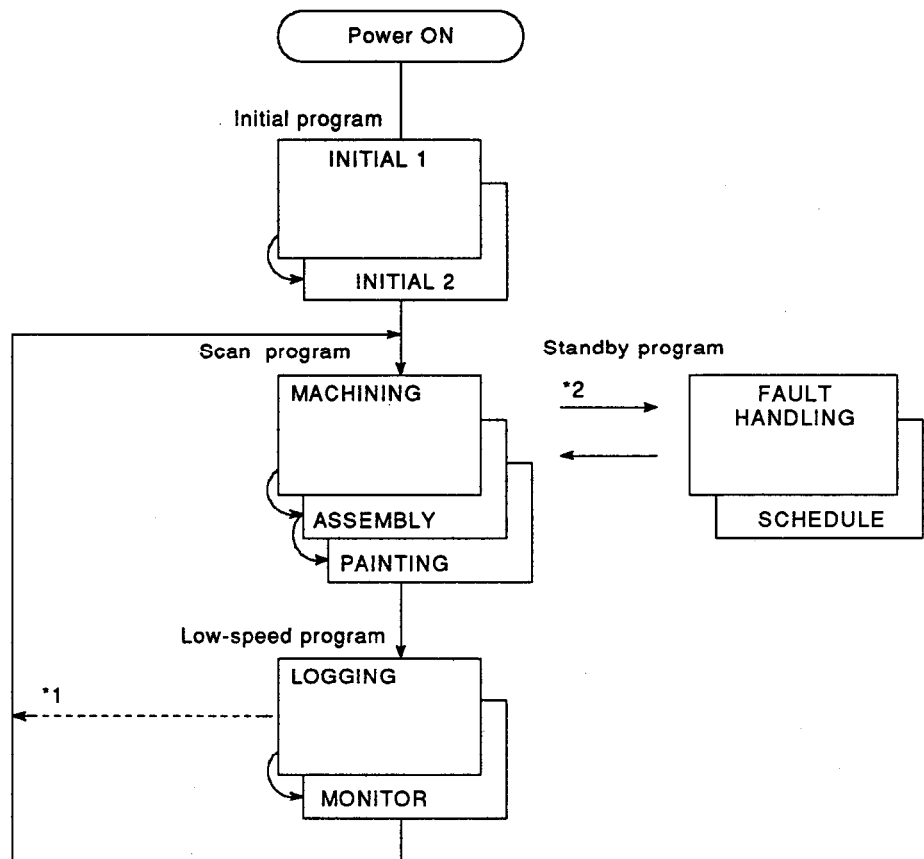

*1 If constant-scan or low-speed program execution time is set.
 *2 On request

4.2.2 Sample program

The example below executes the files listed in the table.

File Name	Type	Description
INITIAL	Initial	Program to set the initial data.
MACHINING	Scan	Program for machining.
ASSEMBLY	Scan	Program for assembly.
TRANSPORT	Scan	Program for transporting.
INSPECTION	Standby	Program for inspection.
MONITOR	Low-speed	Program for monitoring.

- (1) Create each program and write it to the CPU.
Set the RUN/STOP key switch to STOP.
See Chapter 3 for details on programming and writing to the CPU.
- (2) Set the parameters to execute multiple files, and write them to the CPU.

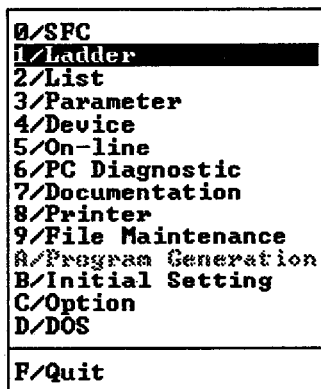

"Mode Select screen"

[3] Select "Parameter"

1)

4. MAKING THE MOST OF YOUR QnACPU (1)

1)

```

[Parameter]                               Label :
Current Status
1.(*) PC Name Definition                   None
2.< > PC System Setting                    Default
3.< > PC File Setting                      Default
4.< > Device Setting                       Default
5.< > PC RAS Setting                       Default
6.< > I/O Allocation                       None
7.< > MELSECNETII, /10 Setting             None
8.< > MELSECNET/MINI Setting              None
9.< > Auxiliary Setting                    Default
A.< > SFC                                  Default

B.< > N/Y Allocation Confirm

Execute<Y>   Cancel<N>
Space:Select Esc:Close
    
```

"Parameter screen"

[5] [Y] Select "PC RAS Setting"

```

[PC RAS Setting]                           Label :
1. WDI                                     [ 200]ms
  1. Setting                               [ 200]ms
  2. Init Exec WDI                         [    ]ms
  3. Slow Exec WDI                         [    ]ms
2. Error Check
  1. Battery Check                         <Yes>
  2. Fuse Blown Check                      <Yes>
  3. I/O Unit Compare                      <Yes>
3. Ope-Mode at Error
  1. Calculation                           <Pause >
  2. Extended Ins                          <Pause >
  3. Fuse Blown                            <Pause >
  4. I/O Unit Compare                      <Pause >
  5. Sp Unit Access                        <Pause >
  6. IC Card Access                        <Pause >
  7. IC Card Operate                       <Pause >
4. Constant Scan [    ]ms
5. Annunciator Display Mode
  1. F # Display                           <Yes>
  2. Comment Display                       <No >
  3. Occurred Time                         <No >
6. Fault History
  1.(*) Internal RAM
  2.< > Following Record Files
      Drive [  ]
      File [    ]
      History[  ]
7. Slow Program Exec Time [    ]ms

Execute<Y>   Cancel<N>
Space:Select Esc:Close
    
```

"PC RAS Setting screen"

[4] [1] [2] [0] [Enter] Set 120 ms constant scan

```

[PC RAS Setting]                           Label :
1. WDI                                     [ 200]ms
  1. Setting                               [ 200]ms
  2. Init Exec WDI                         [    ]ms
  3. Slow Exec WDI                         [    ]ms
2. Error Check
  1. Battery Check                         <Yes>
  2. Fuse Blown Check                      <Yes>
  3. I/O Unit Compare                      <Yes>
3. Ope-Mode at Error
  1. Calculation                           <Pause >
  2. Extended Ins                          <Pause >
  3. Fuse Blown                            <Pause >
  4. I/O Unit Compare                      <Pause >
  5. Sp Unit Access                        <Pause >
  6. IC Card Access                        <Pause >
  7. IC Card Operate                       <Pause >
4. Constant Scan [ 120]ms
5. Annunciator Display Mode
  1. F # Display                           <Yes>
  2. Comment Display                       <No >
  3. Occurred Time                         <No >
6. Fault History
  1.(*) Internal RAM
  2.< > Following Record Files
      Drive [  ]
      File [    ]
      History[  ]
7. Slow Program Exec Time [    ]ms

Execute<Y>   Cancel<N>
Space:Select Esc:Close
    
```

"PC RAS Setting screen"

[Y]

2)

2)

```

[Parameter] Label :
Current Status
1.< > PC Name Definition      None
2.< > PC System Setting      Default
3.< > PC File Setting         Default
4.< > Device Setting          Default
5.<*> PC RAS Setting          Set
6.< > I/O Allocation          None
7.< > MELSECNETII, /18 Setting None
8.< > MELSECNET/MINI Setting None
9.< > Auxiliary Setting       None
A.< > SFC                     Default

B.< > X/Y Allocation Confirm

Execute<Y>  Cancel<N>
Space:Select Esc:Close
    
```

"Parameter screen"

[9] [Y] Select "Auxiliary Setting"

```

[Auxiliary Setting]
Current Status
1.<*> Program                 None
2.< > Boot                    None

Execute<Y>  Cancel<N>
Space:Select Esc:Close
    
```

"Auxiliary Setting screen"

[1] [Y]

```

[Program Setting] Label :
#   Program   Execute
1   [ ]       < >
2   [ ]       < >
3   [ ]       < >
4   [ ]       < >
5   [ ]       < >
6   [ ]       < >
7   [ ]       < >
8   [ ]       < >
9   [ ]       < >
10  [ ]       < >
11  [ ]       < >
12  [ ]       < >

PgUp:Prev PgDn:Next Esc:Close
    
```

"Program Setting screen"

Sets the programs to execute

- [I] [N] [I] [T] [I] [A] [L] [Enter] [SP] [Enter] Set program #1
- [M] [A] [C] [H] [I] [N] [E] [Enter] [Enter] Set program #2
- [A] [S] [S] [E] [M] [B] [L] [Y] [Enter] [Enter] Set program #3
- [T] [R] [A] [N] [S] [F] [E] [R] [Enter] [Enter] Set program #4
- [T] [E] [S] [T] [Enter] [SP] [SP] [SP] [Enter] Set program #5
- [M] [O] [N] [I] [T] [O] [R] [Enter] [SP] [SP] [Enter] Set program #6

3)

3)

[Program Setting]Label :

#	Program	Execute
1	[INITIAL]	<Init>
2	[MACHINE]	<Scan>
3	[ASSEMBLY]	<Scan>
4	[TRANSFER]	<Scan>
5	[TEST]	<Wait>
6	[MONITOR]	<Slow>
7	[]	< >
8	[]	< >
9	[]	< >
10	[]	< >
11	[]	< >
12	[]	< >

PgUp:Prev PgDn:Next Esc:Close

"Program setting screen"

[Esc]

Do you want to register the parameter?
 Yes<Y> No<N>

[Y] Register parameters

[Auxiliary Setting]

	Current Status
1.<*) Program	Set
2.< > Boot	None

Execute<Y> Cancel<N>

Space>Select Esc:Close

"Auxiliary Setting screen"

[Alt] [2] [2] Select "Write to PC"

4)

4. MAKING THE MOST OF YOUR QnACPU (1)

4)

```

[Write to PC]
Interface RS232C <---> QnACPU
Target PC Network : 0 Station : FF PC Type : Q3A
Target Mem Internal RAM Title [ ]
1. File 1. File Name [MAIN ] Title [ ]
2. Igt 2. Igt 1.[*] Parameter
2.[*] Seq/SPC Prog 1.<*) Whole Range [ ] IX Step
2.<*) Step Range [ ] 1-[ ]
3.[ ] Device Comment 3.<*) Step Range P [ ] - [ ]
4.[ ] Dev Init Ualua 4.<*) Block Range [ ] - [ ]
5.[ ] Simulation Data
6.[ ] File Register 1.<*) Whole Range
2.<*) Specify ZRI [ ] - [ ]
2. Device Mem 1.[ ] Internal 1.<*) Whole Range
2.<*) Specify Detail Range
Execute<Y> Cancel<N>
Ctrl+L:List Ctrl+D:Dir Space:Select Esc:Close
    
```

"Write to PC screen"

[SP] [SP] [BS] [BS] [BS] [BS] [P] [A] [R] [A] [M] [↓] [↓] [SP] [↓]

```

[Write to PC]
Interface RS232C <---> QnACPU
Target PC Network : 0 Station : FF PC Type : Q3A
Target Mem Internal RAM Title [ ]
1. File 1. File Name [PARAM ] Title [ ]
2. Igt 2. Igt 1.[*] Parameter
2.[ ] Seg/SEC Prog 1.<*) Whole Range [ ] IX Step
2.<*) Step Range [ ] 1-[ ]
3.[ ] Device Comment 3.<*) Step Range P [ ] - [ ]
4.[ ] Dev Init Ualua 4.<*) Block Range [ ] - [ ]
5.[ ] Simulation Data
6.[ ] File Register 1.<*) Whole Range
2.<*) Specify ZRI [ ] - [ ]
2. Device Mem 1.[ ] Internal 1.<*) Whole Range
2.<*) Specify Detail Range
Execute<Y> Cancel<N>
Ctrl+L:List Ctrl+D:Dir Space:Select Esc:Close
    
```

"Write to PC screen"

[Y] Write parameters to CPU

(3) Execute the programs

*1

Turn the CPU key switch from "STOP" to "RESET" to "RUN".

*1 If the key switch is turned from STOP to RUN.

The CPU displays a message, as follows, and checks the program.

Q2ACPU, Q2ACPU-S1 : RUN LED flashes

Q3ACPU, Q4ACPU : "PRG. CHECK!!" displayed

The CPU runs the programs when the key switch is set from STOP to RESET to RUN.

4.2.3 Program list monitor

Displays the processing time for the program executed in Section 4.2.1

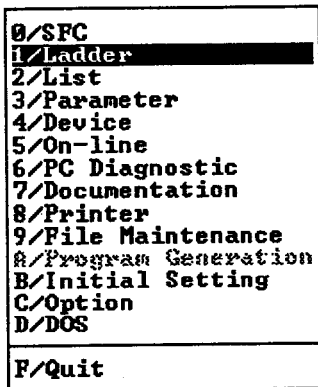

"Mode select screen"

[1] Select "Ladder"

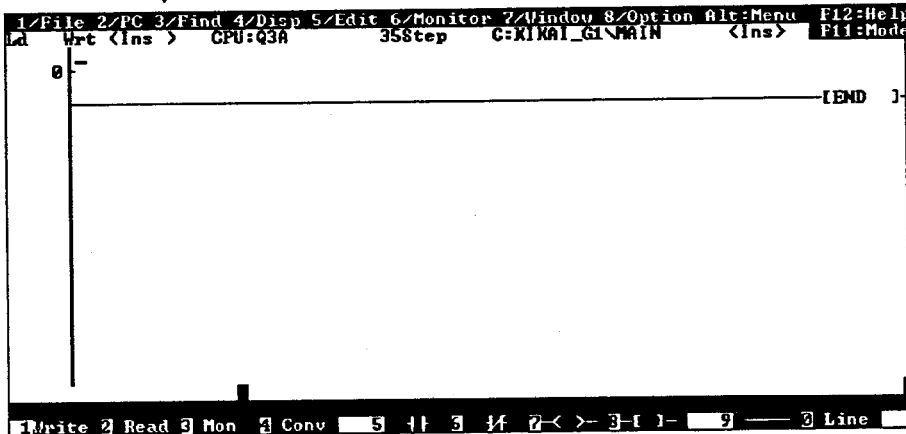

"Ladder Write screen"

[Alt] [2] [4] Select "Newly from PC"

(Match the name of the GPPQ file with the read program name.)

1)

4. MAKING THE MOST OF YOUR QnACPU (1)

1)

```

(Newly from PC)
Interface RS232C <---> QnACPU
Target PC Network : 0 Station : FF PC Type : Q3A
Target Mem Internal RAM Title [ ]
1. File Name [ ] Title [ ]
2. Target 1.[*] Parameter
           2.[*] Seq/SFC Program
           3.[*] Device Comment
           4.[*] Device Initial Value
           5.[ ] Simulation Data
           Execute<Y> Cancel<N>
Ctrl+L:List Ctrl+D:Dir Space:Select Esc:Close
    
```

"Newly from PC screen"

[Ctrl] [L] Display file list

```

(List)
Interface RS232C <---> QnACPU
Target PC Network : 0 Station : FF PC Type : Q3A
Target Mem Internal RAM Title [ ]
File Type Size Date Time Title
PARAM Parameter 404 96-04-29 10:19 [ ]
INITIAL QnA Seq 2148 96-04-29 10:19 [ ]
MACHINE QnA Seq 2148 96-04-29 10:20 [ ]
ASSEMBLY QnA Seq 2148 96-04-29 10:21 [ ]
TRANSFER QnA Seq 2148 96-04-29 10:22 [ ]
TEST QnA Seq 2148 96-04-29 10:23 [ ]
MONITOR QnA Seq 2164 96-04-29 10:24 [ ]
Files :7 MAX Cont 323584 Bytes Exec<Y> Cncl<N>
Free Space 323584 Bytes
PgUp:Prev PgDn:Next Ctrl+D:Dir Space:Select Esc:Close
    
```

"File List screen"

[SP] [↓] [↓] [↓] [↓] [↓] [↓] [SP] [Enter] Select read file

```

(Newly from PC)
Interface RS232C <---> QnACPU
Target PC Network : 0 Station : FF PC Type : Q3A
Target Mem Internal RAM Title [ ]
1. File Name [MONITOR] Title [ ]
2. Target 1.[*] Parameter
           2.[*] Seq/SFC Program
           3.[ ] Device Comment
           4.[ ] Device Initial Value
           5.[ ] Simulation Data
           Execute<Y> Cancel<N>
Ctrl+L:List Ctrl+D:Dir Space:Select Esc:Close
    
```

"Newly from PC screen"

[Y] Read parameters and sequence programs from CPU.

2)

2)

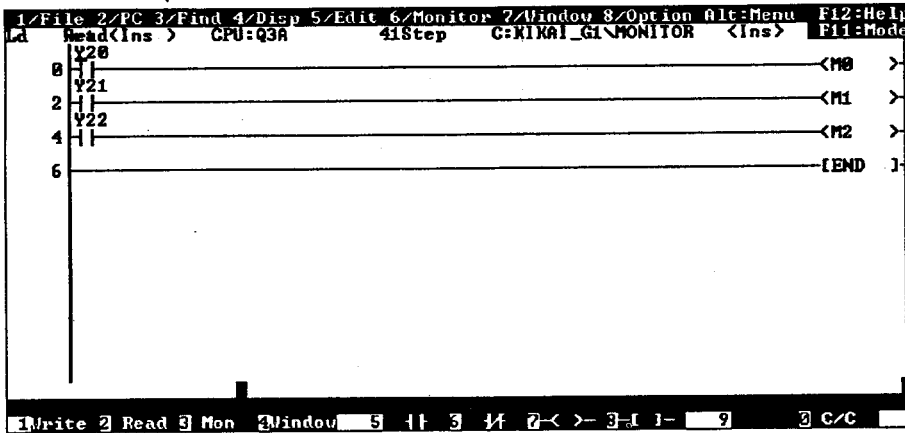

"Ladder Read screen" (example)

[F3] Monitor

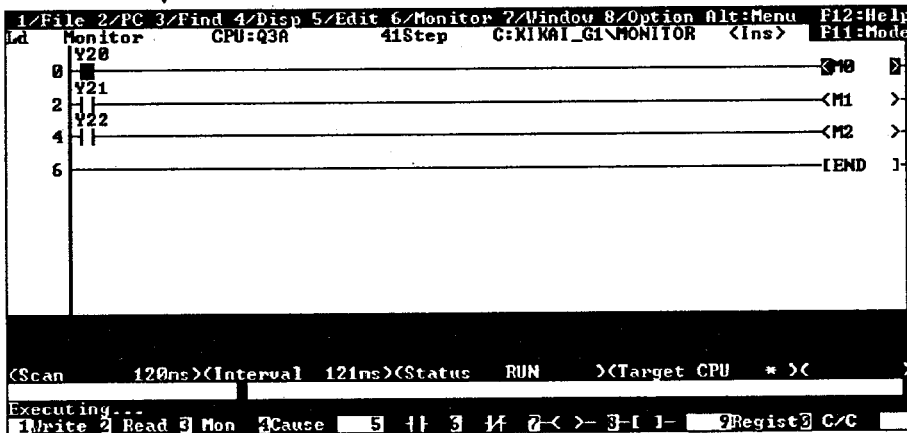

"Ladder Monitor screen"

[Alt] [6] [6] Select "Program Batch Monitor"



"Program Batch Monitor screen"

[1] [Y] Run program batch monitor

3)

3)

[Program List Monitor]			<Program Status> ←(c)				
<Total Scan Time> ←(a)			#	Program	Exec	Scan Time	Ex Times
Scan	200ms	120.000ms	1	INITIAL	Init	0.100ms	1 x
Init	ns	120.000ms	2	MACHINE	Scan	0.100ms	1400 x
Slow	ns	0.200ms	3	ASSEMBLY	Scan	0.100ms	1400 x
<Time Details / Scan> ←(b)			4	TRANSFER	Scan	0.100ms	1400 x
Program		0.300ms	5	TEST	Wait	0.000ms	0 x
END Proc Time		119.700ms	6	MONITOR	Slow	0.300ms	57221 x
Slow Prog		110.600ms	7		Wait	0.000ms	0 x
Wait for Con		112.200ms	8		Wait	0.000ms	0 x
			9		Wait	0.000ms	0 x
			10		Wait	0.000ms	0 x
			11		Wait	0.000ms	0 x

PgUp=Prev PgDn=Next Esc=Close

"Program List Monitor screen" (Displayed values for this example only. Actual values may vary.)

Key to the Screen

(a) "Total Scan Time"

Displays the watchdog times set with "5. PC RAS Setting" in the parameter mode and the total scan time for each program type.

1) "Mon time"

Displays the watchdog times for the scan programs, initial programs, and low-speed programs.

A watchdog error occurs if displayed scan time exceeds the CPU watchdog time.

2) "Max Scan"

Displays the total of the times displayed in "Time Details / Scan".

(b) "Time Details / Scan"

Displays the scan time details.

1) "Program"

Displays the total execution time for the scan programs.

2) "END Proc Time"

Displays the END processing time.

3) "Slow Prog"

Displays the total execution times set for low-speed programs, if low-speed program execution times are set.

4) "Wait for Con"

Displays the constant scan wait time if constant scan is set. However, "0.000 ms" is displayed if a low-speed program execution time is also set.

(c) "Program Status"

Displays the execution status of the programs selected with "9. Auxiliary setting" in the parameter mode.

1) "Program"

Displays the program names in the order of the set parameters.

2) "Exec"

Displays the type of program set with the parameters.

3) "Scan Time"

Displays the actual scan time (present value). The scan time is displayed as "0.000 ms" when program operation is stopped (standby status).

4) "Ex Times"

Displays the number of executions as a value from 0 to 65536, starting from zero when measurement was started. The number of executions value is held when program operation is stopped.

4.3 Easy Programming

4.3.1 Direct access of special-function module buffer memory as devices

The ACPU used FROM/TO instructions for buffer memory read and write operations.
 The QnACPU simplifies sequence programs by allowing direct access of a special-function module buffer memory as devices.

Example Accessing buffer memory addresses 0 and 10 of the special-function module mounted at X/Y40.

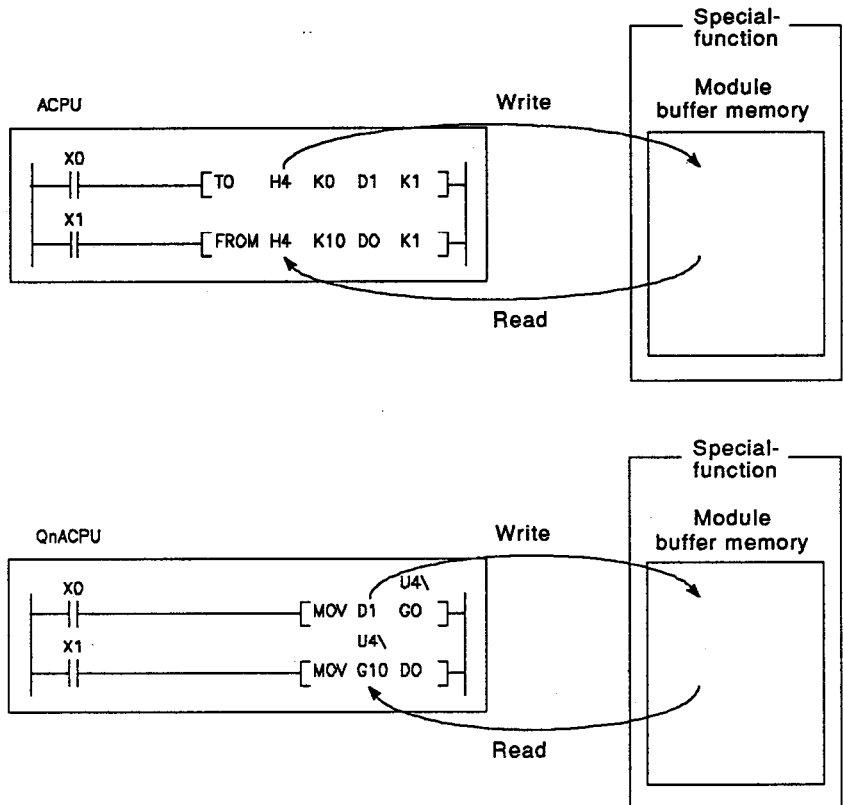

CAUTION

Processing speed with direct access is the same as with the FROM/TO instructions.
 Frequently used buffer memory contents should be temporarily moved to a data register to increase processing speed.

4.3.2 Accessing word devices as bit units and using differential contacts

Bit designation can be used for real numbers, character strings, and word devices.

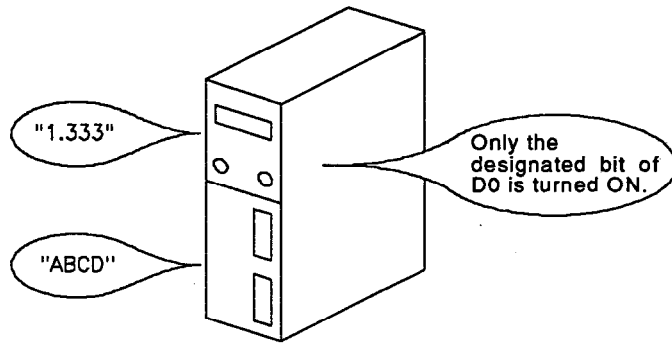

(1) Bit designation

Handles a part of word device data as a bit device.

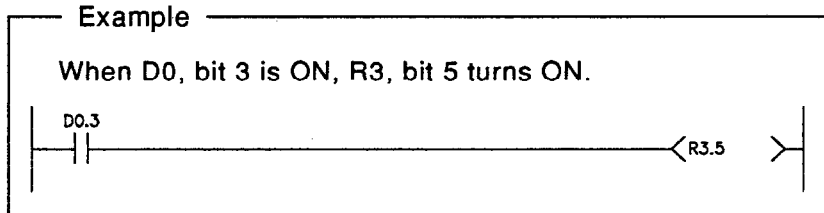

(2) Differential contact

Uses a leading edge or trailing edge as an input device.

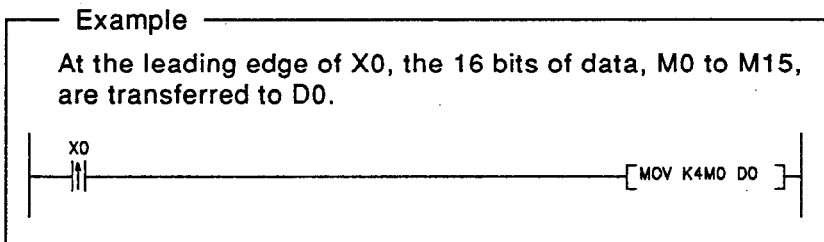

4.4 Convenient Functions When Using QnACPU

4.4.1 Allocation of optimal device points range for the system used

The number of device points was fixed with the conventional ACPUs. However, the QnACPU allows allocation of the optimal device points range to suit the system used.

The settings are shown in the table below.

Item	Description	Setting Range	Default Value
Number of devices	Sets the number of internal device points.	32 k points maximum can be set for one device, in a total range of 29 k words (excluding device X, Y, S).	X : 8 k points (fixed) Y : 8 k points (fixed) M : 8 k points L : 8 k points B : 8 k points F : 2 k points SB : 2 k points V : 2 k points S : 8 k points (fixed) T : 2 k points ST : 0 k point C : 1 k point D : 12 k points W : 8 k points SW : 2 k points
Latch range (latch clear key enabled)	Sets the latch range which can be cleared by the latch clear key.	Only one range per device	No setting
Latch range (latch clear key disabled)	Sets the latch range which cannot be cleared by the latch clear key.	Only one range per device	No setting
Local device range	Set the range of local devices enclosed in the a program.	Only one range per device	No setting

4. MAKING THE MOST OF YOUR QnACPU (1)

MELSEC-QnA

- (1) Change internal relays, M, to 10 k points, and data registers, D, to 1 k points. (D0 to D500: latch clear key enable; D501 to D1023: latch clear key disable)

```
0/SFC
1/Ladder
2/List
3/Parameter
4/Device
5/On-line
6/PC Diagnostic
7/Documentation
8/Printer
9/File Maintenance
A/Program Generation
B/Initial Setting
C/Option
D/DOS
F/Quit
```

"Mode select screen"

[3] Select "Parameter"

```
(Parameter) Label :
Current Status
1.<(*) PC Name Definition None
2.< > PC System Setting Default
3.< > PC File Setting Default
4.< > Device Setting Default
5.< > PC RAS Setting Default
6.< > I/O Allocation None
7.< > MELSECNETII, /10 Setting None
8.< > MELSECNET/MINI Setting None
9.< > Auxiliary Setting
A.< > SFC Default
B.< > X/Y Allocation Confirm
Execute<Y> Cancel<N>
Space:Select Esc:Close
```

"Parameter screen"

[4] [Y] Select "Device Setting"

1)

4. MAKING THE MOST OF YOUR QnACPU (1)

1)

[Device Setting]				Label :	
Device	Sym	Rad	Devices	Enable C/L Key	Disable C/L Key
Input Relay	X	16	8K		
Output Relay	Y	16	8K		
Internal Relay	M	10	[8K]		
Latch Relay	L	10	[8K]		[]-[]
Link Relay	B	16	[8K]	[]-[]	[]-[]
Annunciator	F	10	[2K]	[]-[]	[]-[]
Link Sp Relay	SB	16	2K		
Edge Relay	U	10	[2K]	[]-[]	[]-[]
Step Relay	S	10	8K		
Timer	T	10	[2K]	[]-[]	[]-[]
Accumt Timer	ST	10	[0K]	[]-[]	[]-[]
Counter	C	10	[1K]	[]-[]	[]-[]
Data Register	D	10	[12K]	[]-[]	[]-[]
Link Register	W	16	[8K]	[]-[]	[]-[]
Link Sp Reg	SW	16	2K		

Devices Total<28.8>K Word F3:Latch->LocalDev-> Esc:Close

"Device Setting screen (default values)"

- [←] [Del] [1] [0] [Enter] Change internal relays (M) from 8 k (default) to 10 k.
- [↓] ... Move cursor to data register item.
- [←] [Del] [Del] [1] Change data registers (D) from 12 k (default) to 1 k.
- [→] [→] [0] [→] [5] [0] [0] Set latch clear key enable latch range from D0 to D500.
- [→] [5] [0] [1] [→] [1] [0] [2] [3] [Enter] Set latch clear key disable latch range from D501 to D1023.

[Device Setting]				Label :	
Device	Sym	Rad	Devices	Enable C/L Key	Disable C/L Key
Input Relay	X	16	8K		
Output Relay	Y	16	8K		
Internal Relay	M	10	[10K]		
Latch Relay	L	10	[8K]		[]-[]
Link Relay	B	16	[8K]	[]-[]	[]-[]
Annunciator	F	10	[2K]	[]-[]	[]-[]
Link Sp Relay	SB	16	2K		
Edge Relay	U	10	[2K]	[]-[]	[]-[]
Step Relay	S	10	8K		
Timer	T	10	[2K]	[]-[]	[]-[]
Accumt Timer	ST	10	[0K]	[]-[]	[]-[]
Counter	C	10	[1K]	[]-[]	[]-[]
Data Register	D	10	[1K]	[0]-[500]	[501]-[1023]
Link Register	W	16	[8K]	[]-[]	[]-[]
Link Sp Reg	SW	16	2K		

Devices Total<17.9>K Word F3:Latch->LocalDev-> Esc:Close

"Device Setting screen (set values)"

[Esc]

Do you want to register the parameter?

Yes<Y> No<N>

[Y] Register parameter

4.4.2 Setting device values required by the system as initial values

Device initial values preset in the peripheral device can be automatically transferred to the device memory, file registers, and special-function module when the CPU is switched from STOP to RUN. This eliminates the need for a data initial setting program.

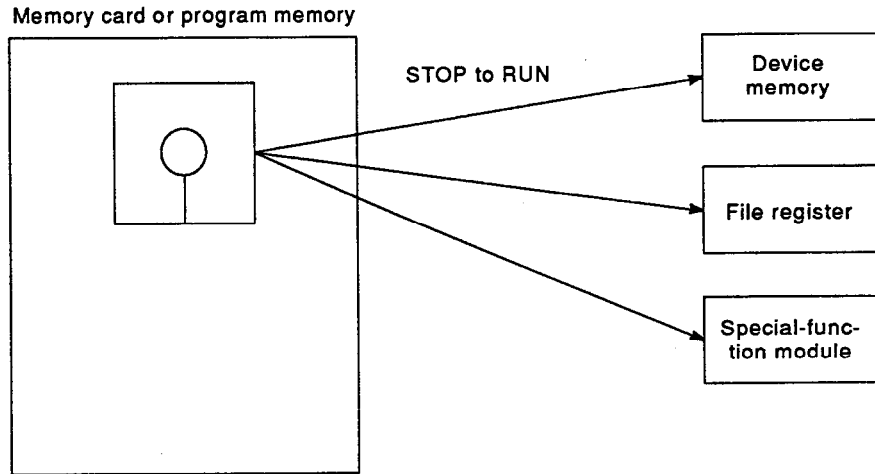

Setting the device initial values

To set the device initial values, the device initial value file must be stored in the CPU program memory or in the memory card. Initial values can be set for the devices listed in the table below.

Device Name	Settable/ Not Settable	Device Name	Settable/ Not Settable	Device Name	Settable/ Not Settable	Device Name	Settable/ Not Settable	Device Name	Settable/ Not Settable
X	x	T (contact)	x	FD	x	SZ	x	U <input type="checkbox"/> \G	o
Y	x	T (coil)	x	B	x	S	x	J <input type="checkbox"/> \X	x
M	x	T (present value)	o	SB	x	TR	x	J <input type="checkbox"/> \Y	x
L	x	C (contact)	x	W	o	BL	x	J <input type="checkbox"/> \B	x
F	x	C (coil)	x	SW	o	U	x	J <input type="checkbox"/> \SB	x
SM	x	C (present value)	o	G	x	J	x	J <input type="checkbox"/> \W	o
FX	x	ST (contact)	x	R	o	ZR	o	J <input type="checkbox"/> \SW	o
FY	x	ST (coil)	x	P	x			J <input type="checkbox"/> \S	x
V	x	ST (present value)	o	I	x			BL <input type="checkbox"/> \S	x
DX	x	D	o	N	x			BL <input type="checkbox"/> \TR	
DY	x	SD	o	Z	x				

4. MAKING THE MOST OF YOUR QnACPU (1)

(1) Set device initial values: D0=0, D1=1, D2=2, D3=3, D4=4, D5=5

```

0/SFC
1/Ladder
2/List
3/Parameter
4/Device
5/On-line
6/PC Diagnostic
7/Documentation
8/Printer
9/File Maintenance
A/Program Generation
B/Initial Setting
C/Option
D/DOS
F/Quit
    
```

"Mode select screen"

[4] Select "Device"

```

1/File 2/PC 3/Find 4/Disp 5/Edit 7/Window 8/Option Alt:Menu F12:Help
Device CPU:Q3A C:\MIXAL_G1\MAIN <Ins> F11:Mode
Device D0
Display:16-Bit Type :Decimal Character String
Device +0 +1 +2 +3 +4 +5 +6 +7 0123456789ABCDEF
D 0 0 0 0 0 0 0 0 0 .....
D 8 0 0 0 0 0 0 0 0 .....
D 16 0 0 0 0 0 0 0 0 .....
D 24 0 0 0 0 0 0 0 0 .....
D 32 0 0 0 0 0 0 0 0 .....
D 40 0 0 0 0 0 0 0 0 .....
D 48 0 0 0 0 0 0 0 0 .....
D 56 0 0 0 0 0 0 0 0 .....
D 64 0 0 0 0 0 0 0 0 .....
D 72 0 0 0 0 0 0 0 0 .....
D 80 0 0 0 0 0 0 0 0 .....
D 88 0 0 0 0 0 0 0 0 .....
D 96 0 0 0 0 0 0 0 0 .....
D 104 0 0 0 0 0 0 0 0 .....
D 112 0 0 0 0 0 0 0 0 .....
D 120 0 0 0 0 0 0 0 0 .....
1Device2 3 2Window 5 3 7 Dec 316Bit 9Value 3
    
```

"Device setting screen (before setting)"

[→] [1] [→] [2] [→] [3] [→] [4] [→] [5]
Set D0=0, D1=1, D2=2, D3=3, D4=4, and D5=5.

1)

4. MAKING THE MOST OF YOUR QnACPU (1)

1)

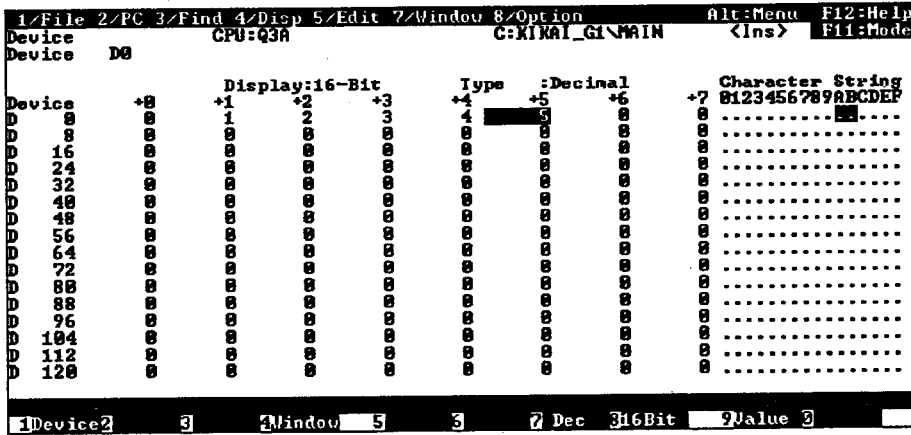

"Device setting screen (after setting)"

[Alt] [5] [4] Select "Device Initial Value Range"

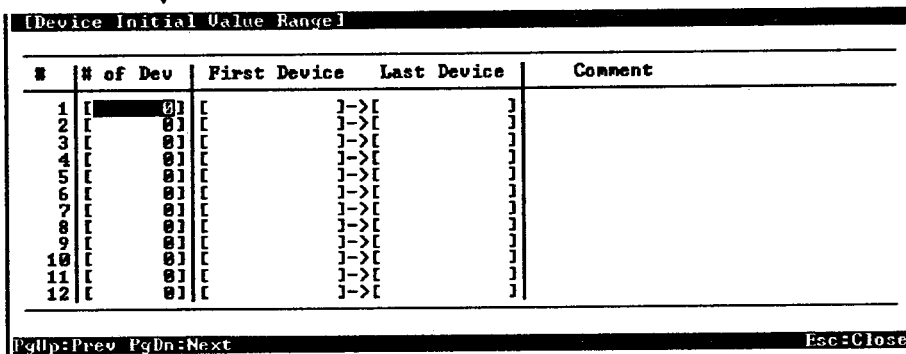

"Device Initial Value Range screen (before setting)"

[6] [→] [D] [0] [Tab] [Enter] Set device initial value range.

2)

2)

[Device Initial Value Range]				
#	# of Dev	First Device	Last Device	Comment
1	[0]	[D0] -> [D5]]
2	[0]	[] -> []]
3	[0]	[] -> []]
4	[0]	[] -> []]
5	[0]	[] -> []]
6	[0]	[] -> []]
7	[0]	[] -> []]
8	[0]	[] -> []]
9	[0]	[] -> []]
10	[0]	[] -> []]
11	[0]	[] -> []]
12	[0]	[] -> []]

PgUp:Prev PgDn:Next Esc:Close

"Device Initial Value Range screen (after setting)"

[Esc]

Do you want to register?
 Yes<Y> No<N> Cancel<S>

[Y] Register device initial value range settings

3)

4. MAKING THE MOST OF YOUR QnACPU (1)

(2) Write device initial values to PC

3)

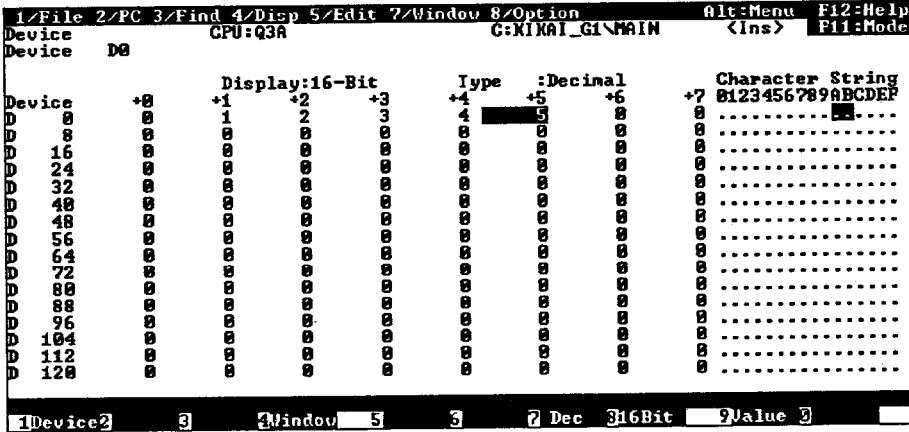

"Device setting screen"

[Alt] [2] [2] Select "Write to PC"

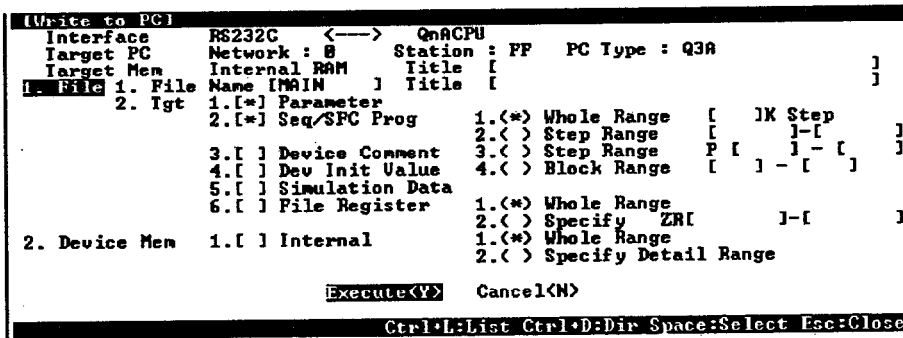

"Write to PC screen"

[SP] [SP] [BS] [BS] [BS] [BS] [I] [N] [I] [T] [I] [A] [L] [1] [Enter] [Enter] [SP]
 [SP] [↓] [SP] [↓] [↓] [SP]
 Set file name to "INITIAL1" and select device initial values

4)

4. MAKING THE MOST OF YOUR QnACPU (1)

4)

```

[Write to PC]
Interface RS232C <---> QnACPU
Target PC Network : 0 Station : FF PC Type : Q3A
Target Mem Internal RAM Title [ ]
1. File 1. File Name [INITIAL1] Title [ ]
   2. Tgt 1. [ ] Parameter
   2. [ ] Seq/SPC Prog 1.<*) Whole Range [ ] JK Step
   3. [ ] Device Comment 2.<*) Step Range [ ] ]-[ ]
   4.<*) Dev Init Value 3.<*) Step Range P [ ] ]-[ ]
   5. [ ] Simulation Data 4.<*) Block Range [ ] ]-[ ]
   6. [ ] File Register 1.<*) Whole Range
   2.<*) Specify ZRI ]-[ ]
2. Device Mem 1. [ ] Internal 1.<*) Whole Range
   2.<*) Specify Detail Range
Execute<Y> Cancel<N>
    
```

"Write to PC screen"

[Y] Execute "Write to PC"

```

1/File 2/PC 3/Find 4/Disp 5/Edit 7/Window 8/Option Alt:Menu F12:Help
Device CPU:Q3A G:KIKAI_G1\MAIN <Ins> F11:Mode
Device D0
Display:16-Bit Type :Decimal Character String
Device +0 +1 +2 +3 +4 +5 +6 +7 0123456789ABCDEF
D 0 0 0 0 0 0 0 0 .....
D 8 0 0 0 0 0 0 0 .....
D 16 0 0 0 0 0 0 0 .....
D 24 0 0 0 0 0 0 0 .....
D 32 0 0 0 0 0 0 0 .....
D 40 0 0 0 0 0 0 0 .....
D 48 0 0 0 0 0 0 0 .....
D 56 0 0 0 0 0 0 0 .....
D 64 0 0 0 0 0 0 0 .....
D 72 0 0 0 0 0 0 0 .....
D 80 0 0 0 0 0 0 0 .....
D 88 0 0 0 0 0 0 0 .....
D 96 0 0 0 0 0 0 0 .....
D 104 0 0 0 0 0 0 0 .....
D 112 0 0 0 0 0 0 0 .....
D 120 0 0 0 0 0 0 0 .....
    
```

"Device setting screen"

5)

(3) Set parameters

Set with the parameters which device initial value file is effective.

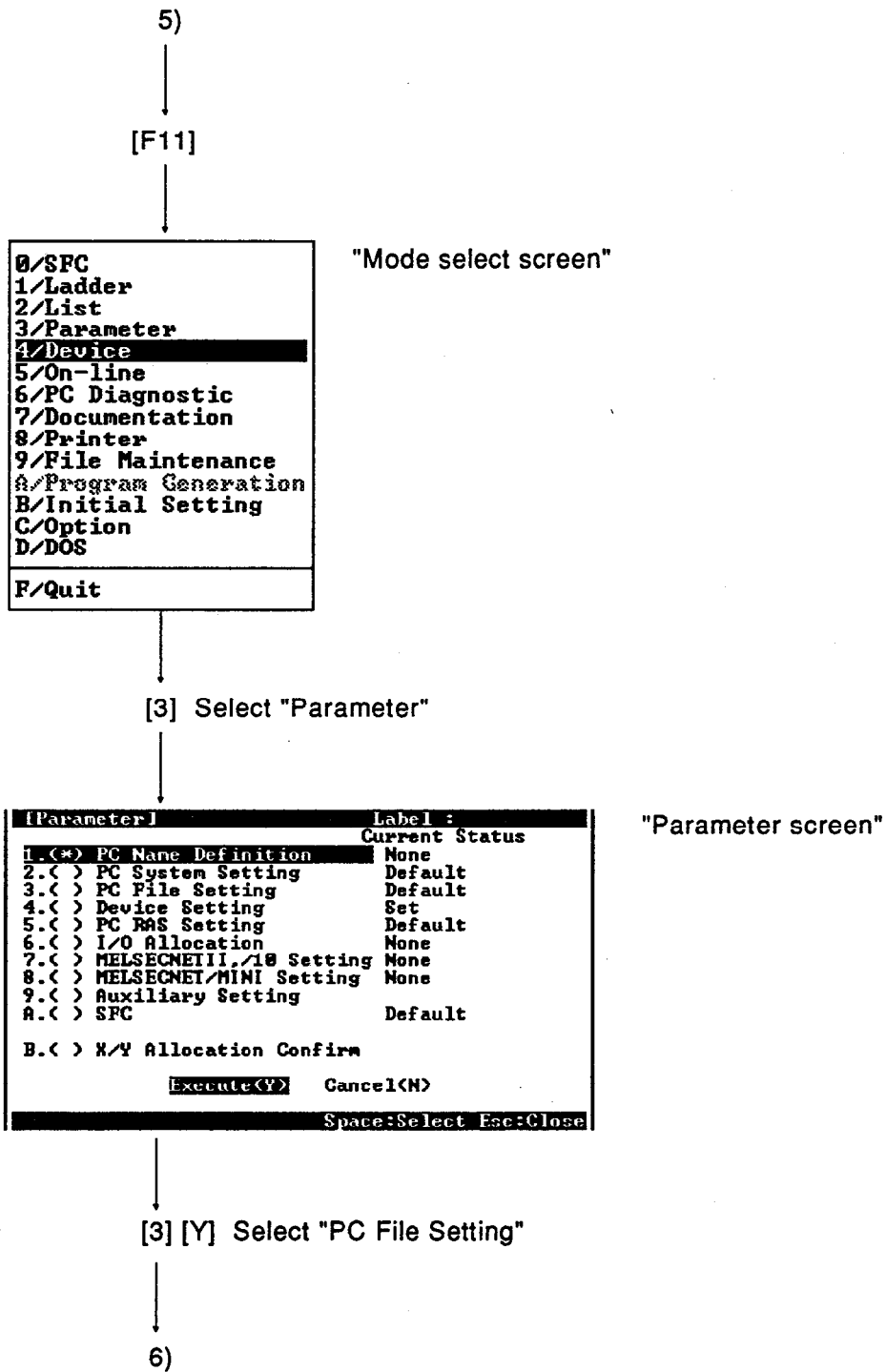

4. MAKING THE MOST OF YOUR QnACPU (1)

6)

```

[PC File Setting]
1. File Register
  1.<*) Not Used
  2.< > Program Name is Used
    Drive [ ]
  3.< > Use the Following Files
    Drive [ ]
    File [ ]
    Capacity [ ] K

2. Comment File Used by Instruction
  1.<*) Not Used
  2.< > Program Name is Used
    Drive [ ]
  3.< > Use the Following Files
    Drive [ ]
    File [ ]

3. Device Initial Value
  1.< > Not Used
  2.<*) Program Name is Used
    Drive [B]
  3.< > Use the Following Files
    Drive [ ]
    File [ ]

4. File for Local Device
  1.<*) Not Used
  2.< > Use the Following Files
    Drive [ ]
    File [ ]

Execute<Y> Cancel<N>
Space>Select Esc:Close
    
```

"PC File Setting screen"

[↓] [↓] [SP] [↓] [SP] [3] [↓] [I] [N] [I] [T] [I] [A] [L] [1] [Enter]

Set the memory card B RAM area file name to "INITIAL1"

```

[PC File Setting]
1. File Register
  1.<*) Not Used
  2.< > Program Name is Used
    Drive [ ]
  3.< > Use the Following Files
    Drive [ ]
    File [ ]
    Capacity [ ] K

2. Comment File Used by Instruction
  1.<*) Not Used
  2.< > Program Name is Used
    Drive [ ]
  3.< > Use the Following Files
    Drive [ ]
    File [ ]

3. Device Initial Value
  1.< > Not Used
  2.<*) Program Name is Used
    Drive [B]
  3.<*) Use the Following Files
    Drive [3]
    File [INITIAL1]

4. File for Local Device
  1.<*) Not Used
  2.< > Use the Following Files
    Drive [ ]
    File [ ]

Execute<Y> Cancel<N>
Space>Select Esc:Close
    
```

"PC File Setting screen"

[Y] Set PC file

```

[Parameter]
Label :
Current Status
1.< > PC Name Definition      None
2.< > PC System Setting      Default
3.<*) PC File Setting        Set
4.< > Device Setting         Set
5.< > PC RAM Setting         Default
6.< > I/O Allocation         None
7.< > MELSECNETII./1B Setting None
8.< > MELSECNET/MINI Setting None
9.< > Auxiliary Setting      None
A.< > SFC                    Default
B.< > X/Y Allocation Confirm

Execute<Y> Cancel<N>
Space>Select Esc:Close
    
```

"Parameter screen"

(4) Execute

Device initial values written when CPU is switched from STOP to RUN or when the power is turned ON.

(5) Cautions

Device initial values take priority when the settings overlap a latch range.

4.4.3 Boot operation with a program transferred from memory card to QnACPU internal memory

A memory card is required for boot operation.

Boot operation is possible by setting the system setting switch and the parameter boot file.

Boot operation is a function for automatic transfer from the memory card to program memory, as defined in the boot file settings, when the power is turned on or the CPU is switched from STOP to RUN.

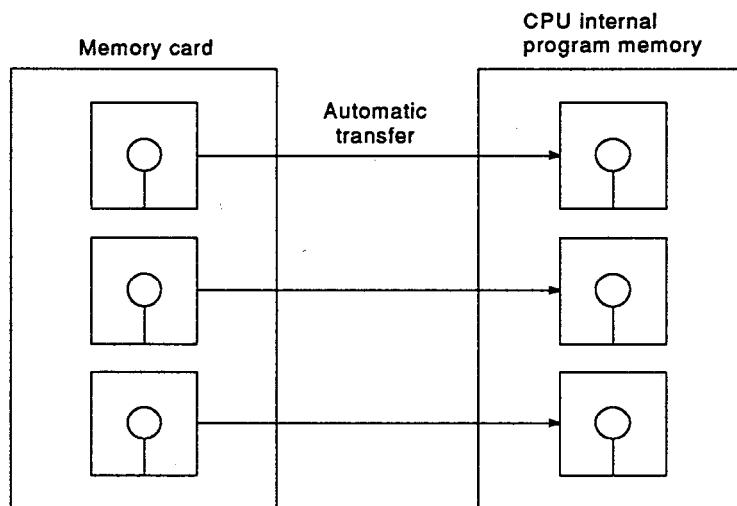

Procedure to Set Boot Operation

The procedure to set boot operation is shown in the flowchart below.

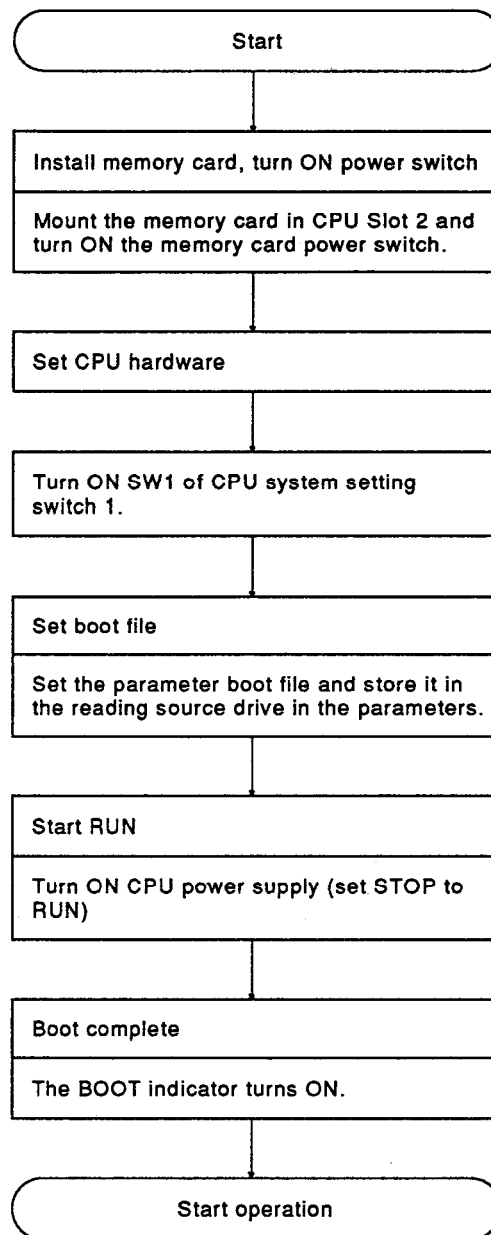

Boot operation is described using the files in the table below.

File Name	Type	Description
INITIAL	Device initial value	Device initial values
MACHINING	Sequence	Program for machining
ASSEMBLY	Sequence	Program for assembly
TRANSPORT	Sequence	Program for transporting

(1) Set switches

Turn ON SW1 of system setting switch 1.

Switch	Setting																																		
NO1	Turn ON to enable boot operation																																		
NO2 NO3 NO4	Designate parameter enabled parameter drive <table border="1" style="margin-left: 20px;"> <thead> <tr> <th>NO4</th> <th>NO3</th> <th>NO2</th> <th>Storage area</th> </tr> </thead> <tbody> <tr> <td>OFF</td> <td>OFF</td> <td>OFF</td> <td>Internal memory (Drive 0:)</td> </tr> <tr> <td>OFF</td> <td>OFF</td> <td>ON</td> <td>Slot 1 RAM (Drive 1:)</td> </tr> <tr> <td>OFF</td> <td>ON</td> <td>OFF</td> <td>Slot 1 ROM (Drive 2:)</td> </tr> <tr> <td>OFF</td> <td>ON</td> <td>ON</td> <td>Slot 2 RAM (Drive 3:)</td> </tr> <tr> <td>ON</td> <td>OFF</td> <td>OFF</td> <td>Slot 2 ROM (Drive 4:)</td> </tr> <tr> <td>ON</td> <td>OFF</td> <td>ON</td> <td rowspan="3">Do not use</td> </tr> <tr> <td>ON</td> <td>ON</td> <td>OFF</td> </tr> <tr> <td>ON</td> <td>ON</td> <td>ON</td> </tr> </tbody> </table>	NO4	NO3	NO2	Storage area	OFF	OFF	OFF	Internal memory (Drive 0:)	OFF	OFF	ON	Slot 1 RAM (Drive 1:)	OFF	ON	OFF	Slot 1 ROM (Drive 2:)	OFF	ON	ON	Slot 2 RAM (Drive 3:)	ON	OFF	OFF	Slot 2 ROM (Drive 4:)	ON	OFF	ON	Do not use	ON	ON	OFF	ON	ON	ON
NO4	NO3	NO2	Storage area																																
OFF	OFF	OFF	Internal memory (Drive 0:)																																
OFF	OFF	ON	Slot 1 RAM (Drive 1:)																																
OFF	ON	OFF	Slot 1 ROM (Drive 2:)																																
OFF	ON	ON	Slot 2 RAM (Drive 3:)																																
ON	OFF	OFF	Slot 2 ROM (Drive 4:)																																
ON	OFF	ON	Do not use																																
ON	ON	OFF																																	
ON	ON	ON																																	

(1) Q2ACPU, Q2ACPU-S1

(2) Q3ACPU, Q4ACPU

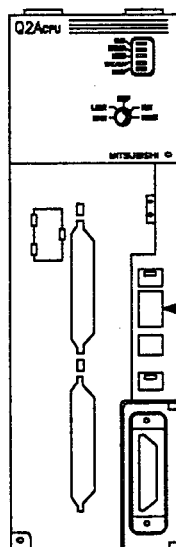

System setting switch 1

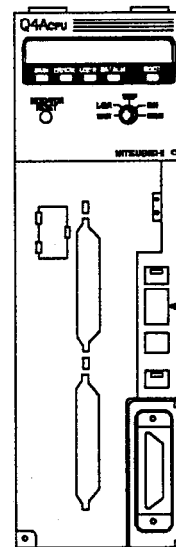

System setting switch 1

* View with front cover open

(2) Set boot file

Set the parameter boot file.

```

0/SFC
1/Ladder
2/List
3/Parameter
4/Device
5/On-line
6/PC Diagnostic
7/Documentation
8/Printer
9/File Maintenance
A/Program Generation
B/Initial Setting
C/Option
D/DOS
F/Quit
    
```

"Mode select screen"

[3] Select "Parameter"

```

[Parameter]
Label :
Current Status
1.<*) PC Name Definition      None
2.< ) PC System Setting      Default
3.< ) PC File Setting         Default
4.< ) Device Setting          Default
5.< ) PC RAS Setting          Default
6.< ) I/O Allocation          None
7.< ) MELSECNETII./I0 Setting None
8.< ) MELSECNET/INI Setting  None
9.< ) Auxiliary Setting      None
A.< ) SFC                     Default
B.< ) X/Y Allocation Confirm

Execute<Y>  Cancel<N>
Space:Select Esc:Close
    
```

"Parameter screen"

[9] [Y] Select "Auxiliary Setting"

1)

1)

[Auxiliary Setting]	
1. (*> Program	Current Status
2. (<) Boot	None
Execute<Y> Cancel<N>	
Space:Select Esc:Close	

"Auxiliary Setting screen"

[2] [Y] Select "Boot"

[Boot Setting]	
1. (*> Boot File	
2. (<) Boot Option	
Execute<Y> Cancel<N>	
Space:Select Esc:Close	

"Boot Setting screen"

[1] [Y] Select "Boot File"

[Boot File Setting]		Label :		
#	Program	Type	IX Src Drive	IX Dest Drive
1	[]	< >	[]	[]
2	[]	< >	[]	[]
3	[]	< >	[]	[]
4	[]	< >	[]	[]
5	[]	< >	[]	[]
6	[]	< >	[]	[]
7	[]	< >	[]	[]
8	[]	< >	[]	[]
9	[]	< >	[]	[]
10	[]	< >	[]	[]
11	[]	< >	[]	[]
12	[]	< >	[]	[]

PgUp:Prev PgDn:Next Esc:Close

"Boot File Setting screen" (before setting)

[I] [N] [I] [T] [I] [A] [L] [Enter] [SP] [SP] [SP] [SP] [Enter] [3] [Enter] [0] [Enter]
 Set program #1
 [M] [A] [C] [H] [I] [N] [E] [Enter] [Enter] [3] [Enter] [0] [Enter] [Enter] [3] [Enter] [0] [Enter]
 Set program #2
 [A] [S] [S] [E] [M] [B] [L] [Y] [Enter] [Enter] [3] [Enter] [0] [Enter]
 Set program #3
 [T] [R] [A] [N] [S] [F] [E] [R] [Enter] [Enter] [3] [Enter] [0] [Enter]
 Set program #4

2)

2)

[Boot File Setting]		Label :		
#	Program	Type	TX Src Drive	TX Dest Drive
1	[INITIAL]	<Dev Init >	[3]	[0]
2	[MACHINE]	<Sequence >	[3]	[0]
3	[ASSEMBLY]	<Sequence >	[3]	[0]
4	[TRANSFER]	<Sequence >	[3]	[0]
5	[]	< >	[]	[]
6	[]	< >	[]	[]
7	[]	< >	[]	[]
8	[]	< >	[]	[]
9	[]	< >	[]	[]
10	[]	< >	[]	[]
11	[]	< >	[]	[]
12	[]	< >	[]	[]

PgUp:Prev PgDn:Next Esc:Close

"Boot File Setting screen (after setting)"

[Esc]

Do you want to register the parameter?
 Yes<Y> No<N>

[Y] Register parameter

3)

(3) Set boot options

During boot operation the ACPU memory contents are cleared but for the QnACPU, program files are written to a free area of internal memory.

Set the boot options as shown below to clear the internal memory. In this case, the parameters are also cleared, so make sure that the CPU system setting switch 1 does not select the internal memory (drive 0) as the enabled parameter drive.

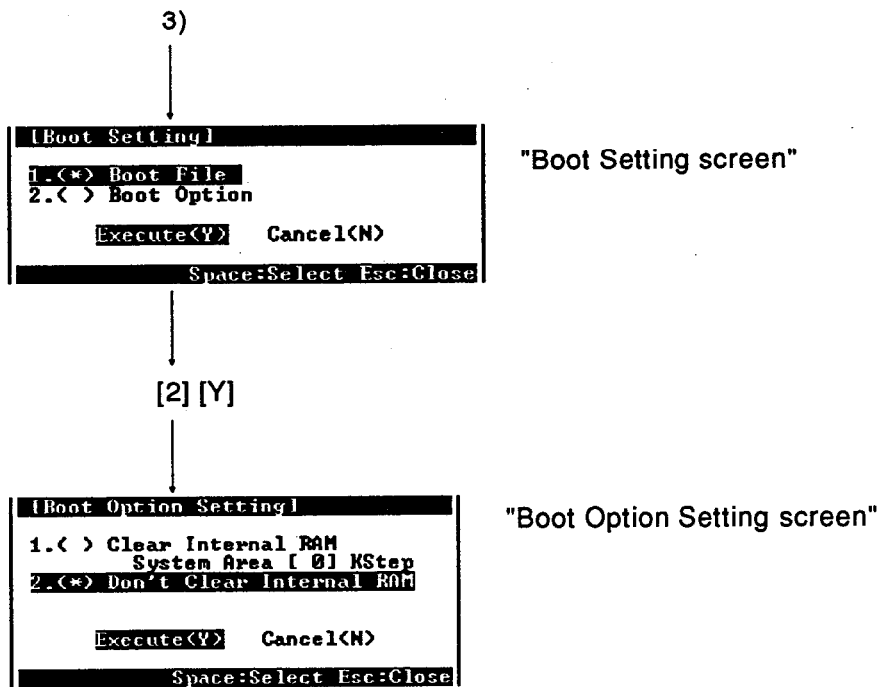

(4) Execution

Boot operation is executed under the following conditions:

- Power turned ON (reset) when the key switch is in the RUN position;
- CPU is switched from STOP to RUN.

The sequence program is executed immediately after boot operation is complete.

(5) Cautions

- During boot operation, a program file with the same name at the transfer destination is overwritten.
- During boot operation, up to 2 or 3 seconds are required to reach RUN status.
- Boot operation is also executed after a power interruption occurs. Therefore, after boot operation has been completed once, turn OFF SW1 of CPU system setting switch 1.
- The transferred file contents may be damaged if the power is turned off or the module is reset during program transfer from the memory card to the internal memory card (boot operation).

4. MAKING THE MOST OF YOUR QnACPU (1)

MELSEC-QnA

4.4.4 Remote operation of the QnACPU from a distant location

Remote operations of the QnACPU are possible, as shown in the table below.

The relationship between the key switch positions and the permitted remote operation is also shown in the table.

Remote Operation Key Switch	RUN	STEP-RUN	STOP	PAUSE	RESET	Latch Clear
RUN	RUN	STEP-RUN	STOP	PAUSE	Remote operation NG	Remote operation NG
STOP	STOP	STOP	STOP	STOP	RESET	Latch clear

(1) Remote RUN/STOP

Set the key switch in the RUN position to carry out remote RUN and STOP.

Two methods are available for remote RUN and STOP:

(a) Method using remote RUN contact

Set the remote RUN contact (X) with the parameters. The CPU is in STOP status when the contact is ON or RUN status when the contact is OFF.

0/SPC
1/Ladder
2/List
3/Parameter
4/Device
5/On-line
6/PC Diagnostic
7/Documentation
8/Printer
9/File Maintenance
A/Program Generation
B/Initial Setting
C/Option
D/DOS
F/Quit

"Mode Select screen"

[3] Select "Parameter"

1)

1)

[Parameter]	Label :	Current Status
1.<*) PC Name Definition		None
2.<) PC System Setting		Default
3.<) PC File Setting		Default
4.<) Device Setting		Default
5.<) PC RAS Setting		Default
6.<) I/O Allocation		None
7.<) MELSECNET11/10 Setting		None
8.<) MELSECNET/MINI Setting		None
9.<) Auxiliary Setting		None
A.<) SFC		Default
B.<) X/Y Allocation Confirm		
Execute<Y> Cancel<N>		
Space>Select Esc:Close		

"Parameter screen"

[2] [Y] Select "PC System Setting"

[PC System Setting]		Label :
1. Timer Interval	1. Slow [100]ms 2. Fast [10]ms	5. Common Pointer # from []
2. RUN-PAUSE Contact	RUN X[] PAUSE X[]	6. General Data Process [1]Unit/try
3. Allow Remote Reset	1.<) Yes 2.<*) No	7. # of Free Slots < 16 >
4. Output at STOP->RUN	1.<*) Prior to Calc 2.<) After one Scan	8. System Interrupt
Execute<Y> Cancel<N>		1. 1st Interrupt Counter CI []
Space>Select Esc:Close		2. I28 Const Interval [100]ms
		3. I29 Const Interval [40]ms
		4. I30 Const Interval [20]ms
		5. I31 Const Interval [10]ms

"PC System Setting screen (before setting)"

[2] [1] [0] Set X10 as RUN contact

[PC System Setting]		Label :
1. Timer Interval	1. Slow [100]ms 2. Fast [10]ms	5. Common Pointer # from []
2. RUN-PAUSE Contact	RUN X[10] PAUSE X[]	6. General Data Process [1]Unit/try
3. Allow Remote Reset	1.<*) Yes 2.<) No	7. # of Free Slots < 16 >
4. Output at STOP->RUN	1.<*) Prior to Calc 2.<) After one Scan	8. System Interrupt
Execute<Y> Cancel<N>		1. 1st Interrupt Counter CI []
Space>Select Esc:Close		2. I28 Const Interval [100]ms
		3. I29 Const Interval [40]ms
		4. I30 Const Interval [20]ms
		5. I31 Const Interval [10]ms

"PC System Setting screen (after setting)"

[Y] Execute PC system setting

- (b) Method using operations from peripheral device or special-function module

Operation is controlled with RUN and STOP instructions from a peripheral device.

The example below shows a remote STOP operation followed by a remote RUN operation.

```

0/SFC
1/Ladder
2/List
3/Parameter
4/Device
5/On-line
6/PC Diagnostic
7/Documentation
8/Printer
9/File Maintenance
A/Program Generation
B/Initial Setting
C/Option
D/DOS
F/Quit
    
```

"Mode Select screen"

[5] Select "On-line"

```

1/File 2/PC 3/Find 4/Trace 6/Test 7/Window Alt:Menu F12:Help
On-line CPU:Q3A NW :IsSt C:\PC F11:Mode

Interface RS232C <---> QnACPU
Target PC Network:0 Sta :FF PC Type:Q3A

Target Memory Contents Title
(Drive)
0 Internal RAM [ ]
1 IC Card A(RAM) [ ]
2 IC Card A(ROM) [ ]
3 IC Card B(RAM) [ ]
4 IC Card B(ROM) [ ]

1)Net PC2Rd PC 3 Test 2Window 5Find 13Select 7 Cut 3 Copy 9 3
    
```

"On-line screen"

[Alt] [2] [7] Select "Remote Operation"

1)

4. MAKING THE MOST OF YOUR QnACPU (1)

1)

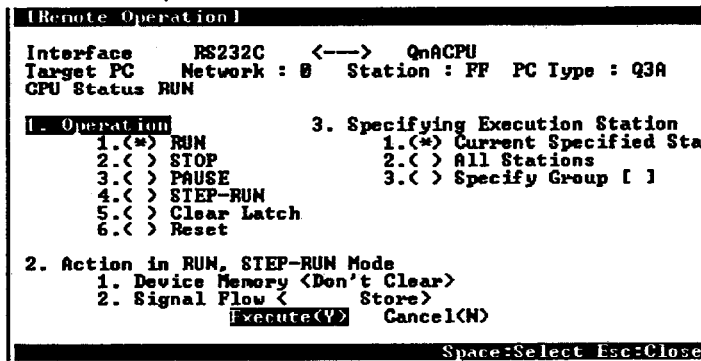

"Remote Operation screen"

[1] [2] [Y] Select "STOP"

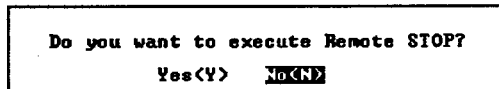

[Y] Execute remote STOP

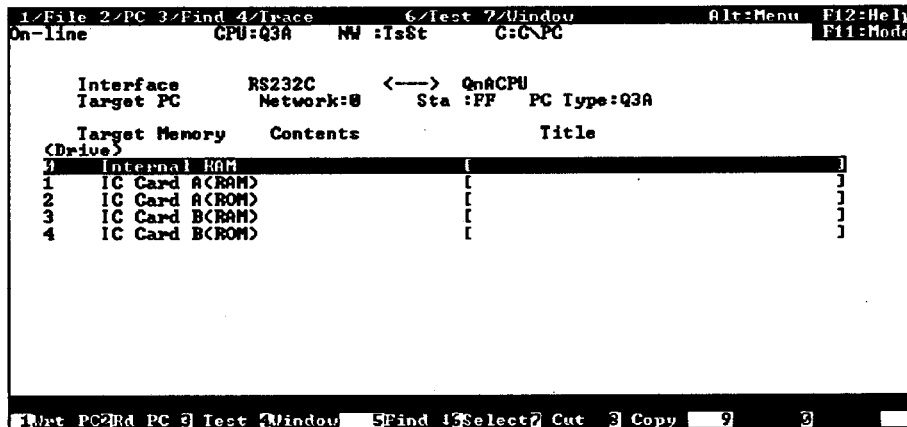

"On-line screen"

[Alt] [2] [7] Select "Remote Operation"

2)

2)

```
Remote Operation
Interface RS232C <--> QnACPU
Target PC Network : 0 Station : FF PC Type : Q3A
CPU Status RUN

1. Operation
1.<*) RUN
2.< > STOP
3.< > PAUSE
4.< > STEP-RUN
5.< > Clear Latch
6.< > Reset

2. Action in RUN, STEP-RUN Mode
1. Device Memory <Don't Clear>
2. Signal Flow < Store>
Execute<Y> Cancel<N>

3. Specifying Execution Station
1.<*) Current Specified Sta
2.< > All Stations
3.< > Specify Group [ ]

Space>Select Esc:Close
```

"Remote Operation screen"

[1] [1] [Y] Select "RUN"

```
Do you want to execute Remote RUN?
Yes<Y> No<N>
```

[Y] Execute remote RUN

(2) Remote PAUSE

When the remote PAUSE is executed, the CPU stops and the I/O status is held.

Set the key switch in the RUN position to carry out remote PAUSE. Two methods are available for remote PAUSE.

(a) Method using remote PAUSE contact

To use the remote PAUSE contact, turn ON the remote PAUSE enable coil (SM206) with the sequence program.

Set the remote PAUSE contact (X) with the parameters. The CPU is in PAUSE status when the contact is ON or RUN status when the contact is OFF.

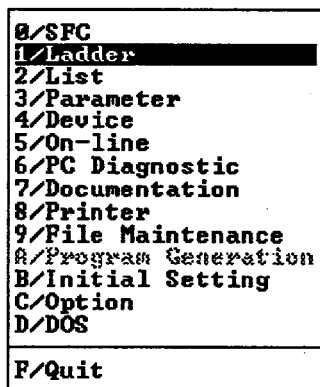

"Mode Select screen"

[3] Select "Parameter"

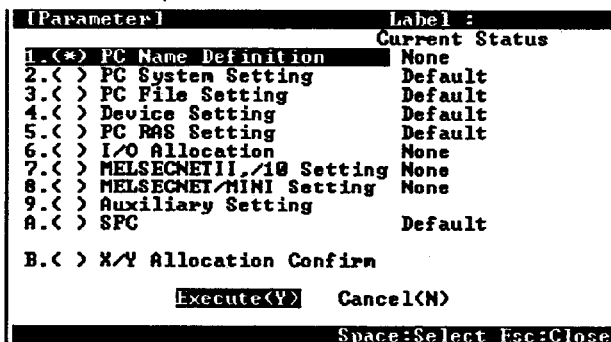

"Parameter screen"

[2] [Y] Select "PC System Setting"

1)

4. MAKING THE MOST OF YOUR QnACPU (1)

1)

```

IPC System Setting] Label :
1. Timer Interval 1. Slow [ 100]ms 5. Common Pointer # from [ ]
                  2. Fast [ 10]ms 6. General Data Process[ 1]Unit/try
2. RUN-PAUSE Contact RUN X[ ] 7. # of Free Slots < 16 >
                  PAUSE X[ ] 8. System Interrupt
3. Allow Remote Reset 1.< > Yes 1. 1st Interrupt Counter CI [ ]
                  2.<*> No 2. I28 Const Interval[ 100]ms
4. Output at STOP->RUN 3. I29 Const Interval[ 40]ms
                  1.<*> Prior to Calc 4. I30 Const Interval[ 20]ms
                  2.< > After one Scan 5. I31 Const Interval[ 10]ms

Execute<Y> Cancel<N>
Space:Select Esc:Close
    
```

"PC System Setting screen (before setting)"

[2][↓][1][1] Set X11 as the PAUSE contact

```

IPC System Setting] Label :
1. Timer Interval 1. Slow [ 100]ms 5. Common Pointer # from [ ]
                  2. Fast [ 10]ms 6. General Data Process[ 1]Unit/try
2. RUN-PAUSE Contact RUN X[ ] 7. # of Free Slots < 16 >
                  PAUSE X[ 11] 8. System Interrupt
3. Allow Remote Reset 1.< > Yes 1. 1st Interrupt Counter CI [ ]
                  2.<*> No 2. I28 Const Interval[ 100]ms
4. Output at STOP->RUN 3. I29 Const Interval[ 40]ms
                  1.<*> Prior to Calc 4. I30 Const Interval[ 20]ms
                  2.< > After one Scan 5. I31 Const Interval[ 10]ms

Execute<Y> Cancel<N>
Space:Select Esc:Close
    
```

"PC System Setting screen (after setting)"

[Y] Set PAUSE contact

(b) Method using operations from peripheral device

Operation is controlled with the remote PAUSE instruction from a peripheral device.

```

0/SFC
1/Ladder
2/List
3/Parameter
4/Device
5/On-line
6/PC Diagnostic
7/Documentation
8/Printer
9/File Maintenance
A/Program Generation
B/Initial Setting
C/Option
D/DOS
F/Quit
    
```

"Mode Select screen"

[5] Select "On-line"

```

1/File 2/PC 3/Find 4/Trace 6/Test 7/Window Alt:Menu F12:Help
On-line CPU:Q3A NW :IsSt C:C:\PC F11:Mode

Interface RS232C <---> QnACPU
Target PC Network:8 Sta :FF PC Type:Q3A

Target Memory Contents Title
(Drive)
0 Internal ROM [ ]
1 IC Card A(CRAM) [ ]
2 IC Card A(CRAM) [ ]
3 IC Card B(CRAM) [ ]
4 IC Card B(CRAM) [ ]

1/Int PC2Rd PC 3 Test 4/Window 5Find 6Select 7 Cut 8 Copy 9
    
```

"On-line screen"

[Alt] [2] [7] Select "Remote Operation"

1)

1)

```
[Remote Operation]
Interface RS232C <--> QnACPU
Target PC Network : B Station : FF PC Type : Q3A
CPU Status RUN

1. Operation
1.<*) RUN
2.< > STOP
3.< > PAUSE
4.< > STEP-RUN
5.< > Clear Latch
6.< > Reset

2. Action in RUN, STEP-RUN Mode
1. Device Memory <Don't Clear>
2. Signal Flow < Store>
Execute<Y> Cancel<N>

3. Specifying Execution Station
1.<*) Current Specified Sta
2.< > All Stations
3.< > Specify Group [ 1 ]

Space>Select Esc:Close
```

"Remote Operation screen"

[SP] [3] [Y] Select "PAUSE"

```
Do you want to execute Remote PAUSE?
Yes<Y> No<N>
```

[Y] Execute remote PAUSE

4. MAKING THE MOST OF YOUR QnACPU (1)

MELSEC-QnA

(3) Remote STEP-RUN

Operation is controlled with the remote STEP-RUN instruction from a peripheral device.

```
0/SFC
1/Ladder
2/List
3/Parameter
4/Device
5/On-line
6/PC Diagnostic
7/Documentation
8/Printer
9/File Maintenance
A/Program Generation
B/Initial Setting
C/Option
D/DOS
F/Quit
```

"Mode Select screen"

[5] Select "On-line"

```
1/File 2/PC 3/Find 4/Trace 6/Test 7/Window Alt:Menu F12:Help
On-line CPU:Q3A NW:IsSt C:C\PC F11:Mode

Interface RS232C <--> QnACPU
Target PC Network:B Sta:FF PC Type:Q3A

Target Memory Contents Title
(Drive)
0 Internal RAM |
1 IC Card A<RAM> |
2 IC Card A<ROM> |
3 IC Card B<RAM> |
4 IC Card B<ROM> |
```

"On-line screen"

[Alt] [2] [7] Select "Remote Operation"

1)

4. MAKING THE MOST OF YOUR QnACPU (1)

1)

```
┌Remote Operation┐
Interface   RS232C  <--->  QnACPU
Target PC   Network : 0   Station : FF  PC Type : Q3A
CPU Status  RUN

1. Operation
1.< * > RUN
2.< > STOP
3.< > PAUSE
4.< > STEP-RUN
5.< > Clear Latch
6.< > Reset

2. Action in RUN, STEP-RUN Mode
1. Device Memory <Don't Clear>
2. Signal Flow < Store >
   Execute<Y>  Cancel<N>

3. Specifying Execution Station
1.< * > Current Specified Sta
2.< > All Stations
3.< > Specify Group [ 1 ]

Space>Select Esc=Close
```

"Remote Operation screen"

[SP] [4] [Y] Select "STEP-RUN"

```
Do you want to execute Remote STEP RUN?
Yes<Y>  No<N>
```

[Y] Execute remote STEP-RUN

(4) Remote latch clear

Set the key switch in the STOP position to carry out remote latch clear. The remote latch clear operation is carried out from the peripheral device.

```

0/SFC
1/Ladder
2/List
3/Parameter
4/Device
5/On-line
6/PC Diagnostic
7/Documentation
8/Printer
9/File Maintenance
A/Program Generation
B/Initial Setting
C/Option
D/DOS
F/Quit
    
```

"Mode Select screen"

[5] Select "On-line"

```

1/File 2/PC 3/Find 4/Trace 6/Test 7/Window Alt:Menu F12:Help
On-line CPU:Q3A MW :IsSt C:C\PC F11:Mode

Interface RS232C <---> QnACPU
Target PC Network:8 Sta :FF PC Type:Q3A

Target Memory Contents Title
(Drive)
0 Internal RAM [ ]
1 IC Card A(ROM) [ ]
2 IC Card A(ROM) [ ]
3 IC Card B(ROM) [ ]
4 IC Card B(ROM) [ ]

[Alt] PC[2]rd PC [3] Test [2]Window [5]Find [4]Select [7] Cut [3] Copy [9] [ ]
    
```

"On-line screen"

[Alt] [2] [7] Select "Remote Operation"

1)

4. MAKING THE MOST OF YOUR QnACPU (1)

1)

```
[Remote Operation]
Interface      RS232C  <--->  QnACPU
Target PC     Network : 0   Station : FF  PC Type : Q3A
CPU Status    RUN

1. Operation
1.<*) RUN
2.< ) STOP
3.< ) PAUSE
4.< ) STEP-RUN
5.< ) Clear Latch
6.< ) Reset

2. Action in RUN, STEP-RUN Mode
1. Device Memory <Don't Clear>
2. Signal Flow < Store>
   Execute<Y>  Cancel<N>

3. Specifying Execution Station
1.<*) Current Specified Sta
2.< ) All Stations
3.< ) Specify Group [ ]

Space:Select Esc:Close
```

"Remote Operation screen"

[SP] [5] [Y] Select "Clear Latch"

```
Do you want to execute Remote L.CLR?
Yes<Y>  No<N>
```

[Y] Execute Remote L.CLR

4. MAKING THE MOST OF YOUR QnACPU (1)

(5) Remote RESET

Set the key switch in the STOP position to carry out remote RESET. Enable remote RESET with the parameters and carry out the remote RESET operation from the peripheral device.

```
0/SFC
1/Ladder
2/List
3/Parameter
4/Device
5/On-line
6/PC Diagnostic
7/Documentation
8/Printer
9/File Maintenance
A/Program Generation
B/Initial Setting
C/Option
D/DOS
F/Quit
```

"Mode Select screen"

[3] Select "Parameter"

```
[Parameter] Label :
Current Status
1.<*> PC Name Definition None
2.< > PC System Setting Default
3.< > PC File Setting Default
4.< > Device Setting Default
5.< > PC RAS Setting Default
6.< > I/O Allocation None
7.< > MELSECNETII./10 Setting None
8.< > MELSECNET/MINI Setting None
9.< > Auxiliary Setting
A.< > SFC Default
B.< > X/Y Allocation Confirm
Execute<Y> Cancel<N>
Space:Select Esc:Close
```

"Parameter screen"

[2] [Y] Select "PC System Setting"

1)

4. MAKING THE MOST OF YOUR QnACPU (1)

1)

```

IPC System Setting] Label :
1. Timer Interval 1. Slow [ 100]ms 5. Common Pointer # from [ ]
                  2. Fast [ 10]ms 6. General Data Process[ 1]Unit/try
2. RUN-PAUSE Contact RUN X[ ] 7. # of Free Slots < 16 >
                  PAUSE X[ ] 8. System Interrupt
3. Allow Remote Reset 1.< > Yes 1. 1st Interrupt Counter CI [ ]
                  2.< * > No 2. I28 Const Intervall 100]ms
4. Output at STOP->RUN 3. I29 Const Intervall 40]ms
                  1.< * > Prior to Calc 4. I30 Const Intervall 20]ms
                  2.< > After one Scan 5. I31 Const Intervall 10]ms
Execute<Y> Cancel<N>
Space:Select Esc:Close
    
```

"PC System Setting screen (before setting)"

[3] [1] Select "Allow Remote Reset Yes"

```

IPC System Setting] Label :
1. Timer Interval 1. Slow [ 100]ms 5. Common Pointer # from [ ]
                  2. Fast [ 10]ms 6. General Data Process[ 1]Unit/try
2. RUN-PAUSE Contact RUN X[ ] 7. # of Free Slots < 16 >
                  PAUSE X[ ] 8. System Interrupt
3. Allow Remote Reset 1.< * > Yes 1. 1st Interrupt Counter CI [ ]
                  2.< > No 2. I28 Const Intervall 100]ms
4. Output at STOP->RUN 3. I29 Const Intervall 40]ms
                  1.< * > Prior to Calc 4. I30 Const Intervall 20]ms
                  2.< > After one Scan 5. I31 Const Intervall 10]ms
Execute<Y> Cancel<N>
Space:Select Esc:Close
    
```

"PC System Setting screen (after setting)"

[Y] Set "Allow Remote Reset Yes"

2)

2)

[Parameter]	Label :	Current Status
1.< > PC Name Definition		None
2.<*) PC System Setting		Set
3.< > PC File Setting		Default
4.< > Device Setting		Default
5.< > PC RAS Setting		Default
6.< > I/O Allocation		None
7.< > MELSECNETII./10 Setting		None
8.< > MELSECNETI/MINI Setting		None
9.< > Auxiliary Setting		
A.< > SFC		Default
B.< > X/Y Allocation Confirm		
Execute<V>		Cancel<N>
Space:Select Esc:Close		

"Parameter screen"

[F11] Select "Mode Select screen"

0/SFC
1/Ladder
2/List
3/Parameter
4/Device
5/On-line
6/PC Diagnostic
7/Documentation
8/Printer
9/File Maintenance
8/Program Generation
B/Initial Setting
C/Option
D/DOS
F/Quit

"Mode Select screen"

[5] Select "On-line"

3)

4. MAKING THE MOST OF YOUR QnACPU (1)

3)

```

1/File 2/PC 3/Find 4/Trace          6/Test 7/Window      Alt:Menu  F12:Help
On-line          CPU:Q3A   HW :IsSt   C:C\PC          F11:Mode

Interface      RS232C   <--->  QnACPU
Target PC      Network:8   Sta :FF   PC Type:Q3A

Target Memory  Contents          Title
( Drive )
3 Internal RAM [ ]
1 IC Card A(RAM) [ ]
2 IC Card A(ROM) [ ]
3 IC Card B(RAM) [ ]
4 IC Card B(ROM) [ ]
    
```

"On-line screen"

[Alt] [2] [7] Select "Remote Operation"

```

[Remote Operation]

Interface      RS232C   <--->  QnACPU
Target PC      Network : 0   Station : FF   PC Type : Q3A
CPU Status RUN

1. Operation
  1.<*> RUN
  2.< > STOP
  3.< > PAUSE
  4.< > STEP-RUN
  5.< > Clear Latch
  6.< > Reset

2. Action in RUN, STEP-RUN Mode
  1. Device Memory <Don't Clear>
  2. Signal Flow <Store>
     Execute<Y>   Cancel<N>

3. Specifying Execution Station
  1.<*> Current Specified Sta
  2.< > All Stations
  3.< > Specify Group [ ]

Space:Select Esc:Close
    
```

[SP] [6] Select "Reset"

```

Do you want to execute Remote RESET?
Yes<Y>   No<N>
    
```

[Y] Execute Remote RESET

4.4.5 What are local devices?

The QnACPU is able to handle each device in each program file as a separate device. These devices are called "local devices."

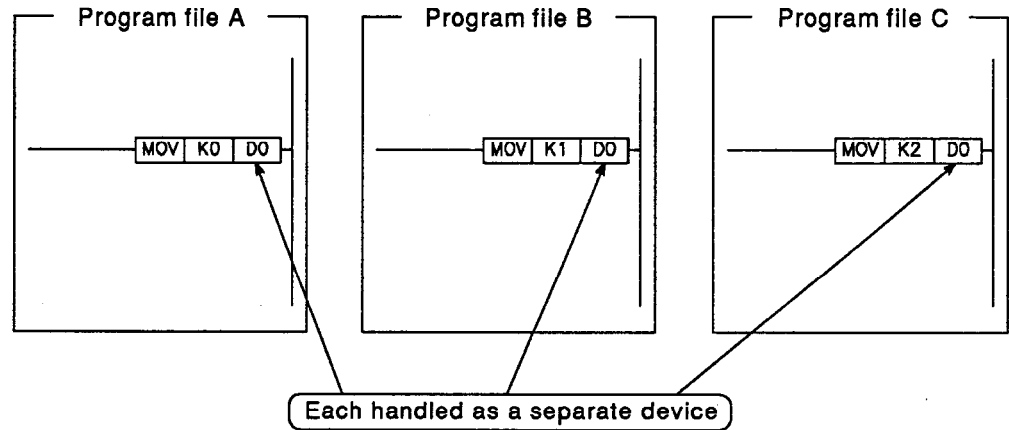

- A memory card is required to use local devices.
- Parameter settings are required to use local devices.
- The following devices can be used as local devices.
 - M : internal relay
 - V : edge relay
 - T : normal timer
 - ST : retentive timer
 - C : counter
 - D : data register

4. MAKING THE MOST OF YOUR QnACPU (1)

MELSEC-QnA

- (1) Set 1 k point (M0 to M1023) of the internal relays as local devices

```
0/SFC
1/Ladder
2/List
3/Parameter
4/Device
5/On-line
6/PC Diagnostic
7/Documentation
8/Printer
9/File Maintenance
A/Program Generation
B/Initial Setting
C/Option
D/DOS
F/Quit
```

"Mode Select screen"

[3] Select "Parameter"

```
(Parameter)
Label :
Current Status
1.<(*)> PC Name Definition      None
2.<> PC System Setting        Default
3.<> PC File Setting          Default
4.<> Device Setting           Default
5.<> PC RAS Setting           Default
6.<> I/O Allocation           None
7.<> MELSECNETII,/10 Setting  None
8.<> MELSECNET/mini Setting   None
9.<> Auxiliary Setting        None
A.<> SFC                      Default
B.<> X/Y Allocation Confirm

Execute<Y>   Cancel<N>
Space:Select Esc:Close
```

"Parameter screen"

[4] [Y] Select "Device Setting"

1)

4. MAKING THE MOST OF YOUR QnACPU (1)

1)

[Device Setting]					Label :	
Device	Sym	Rad	Devices	Enable C/L Key	Disable C/L Key	
Input Relay	X	16	8K			
Output Relay	Y	16	8K			
Internal Relay	M	10	[8K]			
Latch Relay	L	10	[8K]		[]-[]	[]
Link Relay	B	16	[8K]	[]	[]-[]	[]
Annunciator	F	10	[2K]	[]	[]-[]	[]
Link Sp Relay	SB	16	2K			
Edge Relay	U	10	[2K]	[]	[]-[]	[]
Step Relay	S	10	8K			
Timer	T	10	[2K]	[]	[]-[]	[]
Accult Timer	ST	10	[8K]	[]	[]-[]	[]
Counter	C	10	[1K]	[]	[]-[]	[]
Data Register	D	10	[12K]	[]	[]-[]	[]
Link Register	W	16	[8K]	[]	[]-[]	[]
Link Sp Reg	SW	16	2K			

Devices Total<28.8>K Word

F3:Latch->LocalDev-> Esc:Close

"Device Setting screen (before setting)"

[F3] Change from latch to local devices

[Device Setting]					Label :	
Device	Sym	Rad	Devices	Local Device		
Input Relay	X	16	8K			
Output Relay	Y	16	8K			
Internal Relay	M	10	[8K]	[]	[]-[]	[]
Latch Relay	L	10	[8K]			
Link Relay	B	16	[8K]			
Annunciator	F	10	[2K]			
Link Sp Relay	SB	16	2K			
Edge Relay	U	10	[2K]	[]	[]-[]	[]
Step Relay	S	10	8K			
Timer	T	10	[2K]	[]	[]-[]	[]
Accult Timer	ST	10	[8K]	[]	[]-[]	[]
Counter	C	10	[1K]	[]	[]-[]	[]
Data Register	D	10	[12K]	[]	[]-[]	[]
Link Register	W	16	[8K]	[]	[]-[]	[]
Link Sp Reg	SW	16	2K			

Devices Total<28.8>K Word

F3:Latch->LocalDev-> Esc:Close

"Device Setting screen (before setting)"

[←] [Del] [Del] [1] [Tab] [0] [Tab] [1] [0] [2] [3] [Enter]

Set M0 to M1023 as local devices.

2)

4. MAKING THE MOST OF YOUR QnACPU (1)

2)

[Device Setting]				Label :	
Device	Sym	Rad	Devices	Local Device	
Input Relay	X	16	8K		
Output Relay	Y	16	8K		
Internal Relay	M	10	[1K]	[0]-[1023]	
Latch Relay	L	10	[8K]		
Link Relay	B	16	[8K]		
Annunciator	F	10	[2K]		
Link Sp Relay	SB	16	2K		
Edge Relay	U	10	[2K]	[]-[]	
Step Relay	S	10	8K	[]-[]	
Timer	T	10	[2K]	[]-[]	
Accumt Timer	ST	10	[8K]	[]-[]	
Counter	C	10	[1K]	[]-[]	
Data Register	D	10	[12K]	[]-[]	
Link Register	W	16	[8K]		
Link Sp Reg	SW	16	2K		
Devices Total<28.4>K Word				F3:Latch->LocalDev-> Esc:Close	

"Device Setting screen (after setting)"

[Esc]

Do you want to register the parameter?

Yes<Y> No<N>

[Y] Register the parameter

4.5 Easy Program Debugging

This section describes the easy debugging functions.

4.5.1 Simultaneous monitoring by multiple operators

Monitoring is possible by multiple operators. Setting the other station monitor file in the system settings allows high-speed monitoring. (Setting of the host station monitor file is not required). Each other station monitor file occupies 1 k step.

(1) Setting the other station monitor file

```

0/SFC
1/Ladder
2/List
3/Parameter
4/Device
5/On-line
6/PC Diagnostic
7/Documentation
8/Printer
9/File Maintenance
A/Program Generation
B/Initial Setting
C/Option
D/DOS
F/Quit
    
```

"Mode Select screen"

[5] Select "On-line"

```

1/File 2/PC 3/Find 4/Trace 6/Test 7/Window Alt:Menu F12:Help
On-line CPU:Q3A MW :IsSt C:G\PC F11:Mode

Interface RS232C <---> QnACPU
Target PC Network:0 Sta :FF PC Type:Q3A

Target Memory Contents Title
<Drive>
0 Internal RAM [ ]
1 IC Card A(CRAM) [ ]
2 IC Card A(CROM) [ ]
3 IC Card B(CRAM) [ ]
4 IC Card B(CROM) [ ]

1/Int PC2Rd PC 3 Test 4Window 5Find 4Select 7 Cut 3 Copy 9
    
```

"On-line screen"

[Alt] [2] [B] Select "PC Memory Batch Processing"

1)

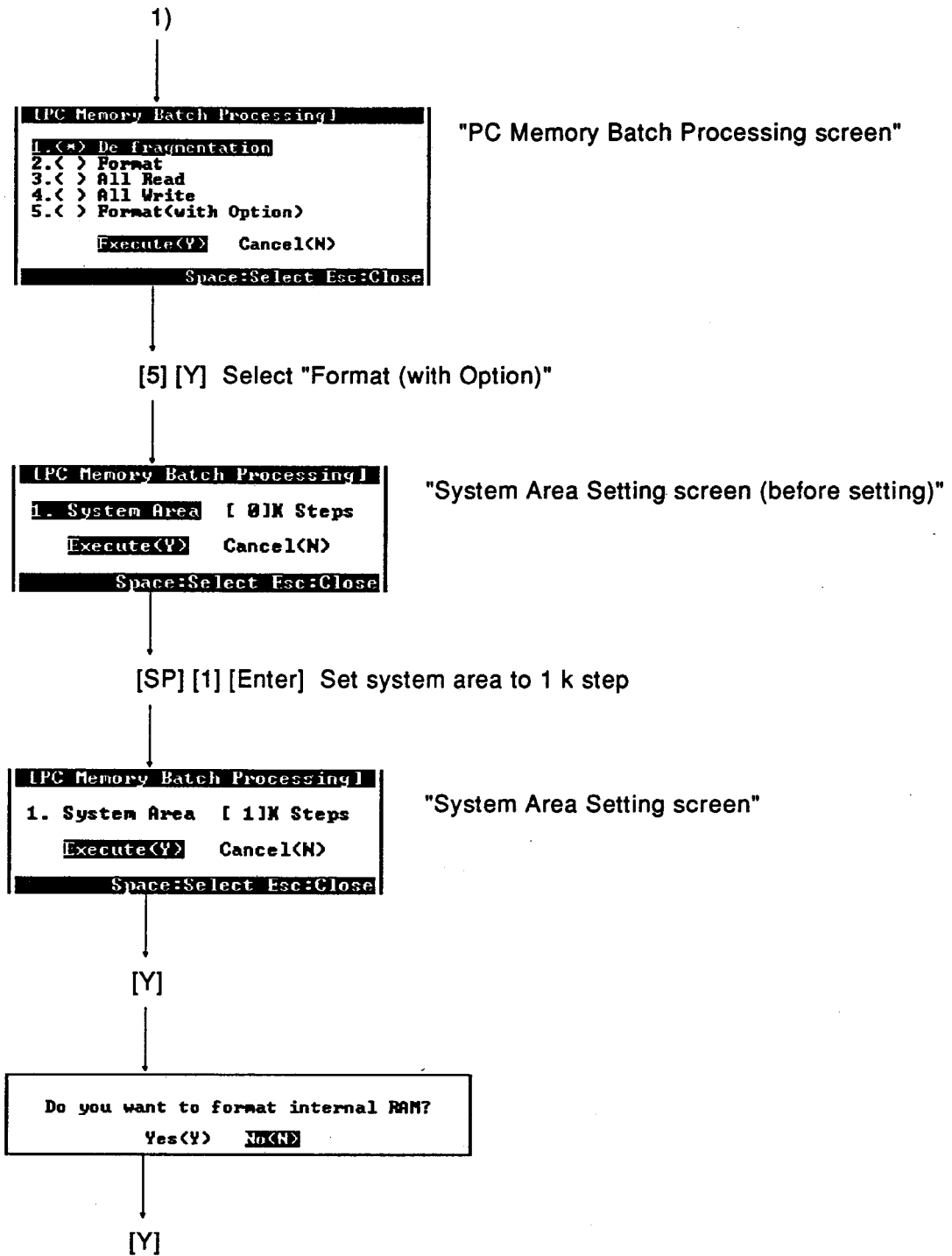

(2) Monitor
See Chapter 3 for information about monitoring.

4.5.2 Monitoring devices at any step

Monitor conditions can be set for precise monitoring of the PC operating status or monitoring of local devices.

In addition to monitoring during the END processing, the monitor conditions allow monitoring to be set at a step number, a step continuity state, or a device state.

- (1) Read the monitored file from the PC CPU

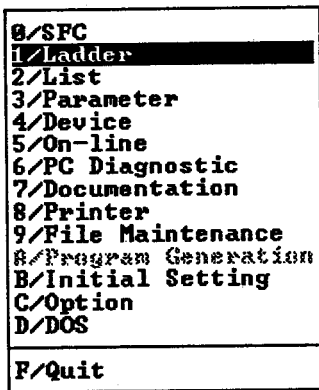

"Mode Select screen"

[1] Select "Ladder"

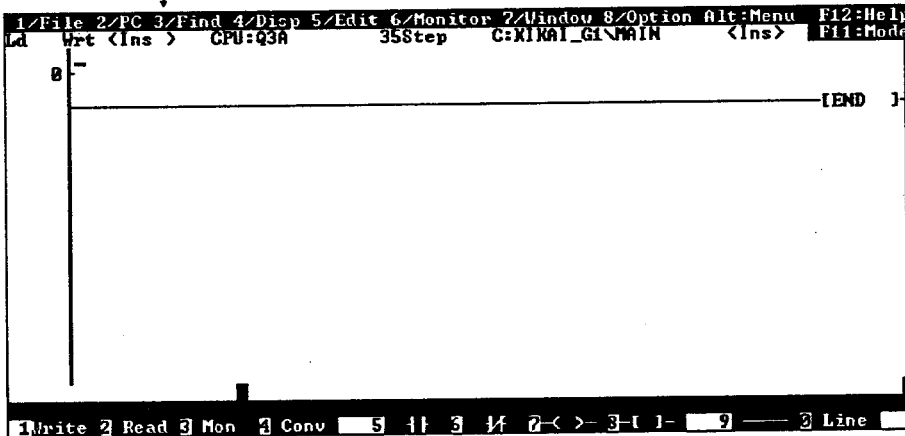

"Ladder Write screen"

[Alt] [2] [4] Select "Newly from PC"

1)

POINT

Select "Newly from PC" to match the GPP file name with the CPU file name.

4. MAKING THE MOST OF YOUR QnACPU (1)

1)

```

(Newly from PC)
Interface RS232C <---> QnACPU
Target PC Network : 0 Station : FF PC Type : Q3A
Target Mem Internal RAM Title [ ]
1. File Name [ ] Title [ ]
2. Target 1.[*] Parameter
           2.[*] Seq/SFC Program
           3.[*] Device Comment
           4.[*] Device Initial Value
           5.[ ] Simulation Data
           Execute<Y> Cancel<N>
Ctrl+L:List Ctrl+D:Dir Space:Select Esc:Close
    
```

"Newly from PC screen"

[Ctrl] [L] Display file list

```

(List)
Interface RS232C <---> QnACPU
Target PC Network : 0 Station : FF PC Type : Q3A
Target Mem Internal RAM Title [ ]
File Type Size Date Time Title
PARAM Parameter 2652 96-04-29 10:35 [ ]
INITIAL QnA Seq 2148 96-04-29 10:19 [ ]
INITIAL1 Dev Init 122 96-04-29 10:56 [ ]
MACHINE QnA Seq 2148 96-04-29 10:20 [ ]
ASSEMBLY QnA Seq 2148 96-04-29 10:21 [ ]
TRANSFER QnA Seq 2148 96-04-29 10:22 [ ]
TEST QnA Seq 2148 96-04-29 10:23 [ ]
MONITOR QnA Seq 2164 96-04-29 10:35 [ ]
Files : 8 MAX Cont 319488 Bytes Exec<Y> Cncl<N>
Free Space 319488 Bytes
PgUp:Prev PgDn:Next Ctrl+D:Dir Space:Select Esc:Close
    
```

"File name display screen (before selecting)"

[SP] [↓] [↓] [↓] [↓] [↓] [↓] [SP]
Select parameter and the file name "MONITOR"

```

(List)
Interface RS232C <---> QnACPU
Target PC Network : 0 Station : FF PC Type : Q3A
Target Mem Internal RAM Title [ ]
File Type Size Date Time Title
*PARAM Parameter 2652 96-04-29 10:35 [ ]
INITIAL QnA Seq 2148 96-04-29 10:19 [ ]
INITIAL1 Dev Init 122 96-04-29 10:56 [ ]
MACHINE QnA Seq 2148 96-04-29 10:20 [ ]
ASSEMBLY QnA Seq 2148 96-04-29 10:21 [ ]
TRANSFER QnA Seq 2148 96-04-29 10:22 [ ]
TEST QnA Seq 2148 96-04-29 10:23 [ ]
*MONITOR QnA Seq 2164 96-04-29 10:35 [ ]
Files : 8 MAX Cont 319488 Bytes Exec<Y> Cncl<N>
Free Space 319488 Bytes
PgUp:Prev PgDn:Next Ctrl+D:Dir Space:Select Esc:Close
    
```

"File name display screen (after selecting)"

[Enter]

2)

3)

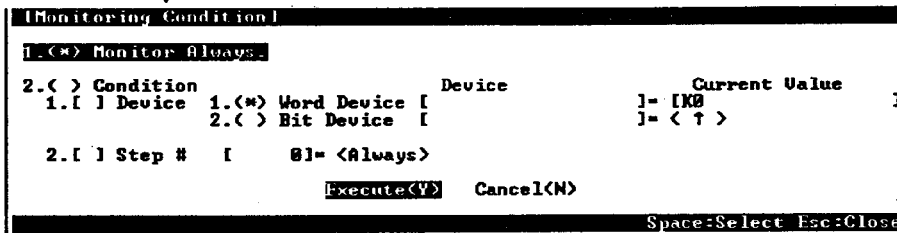

"Monitoring Condition screen (before setting)"

[2] [1] [Tab] [2] [X] [2] [Tab]
Set leading edge of bit device X2 as the monitor condition

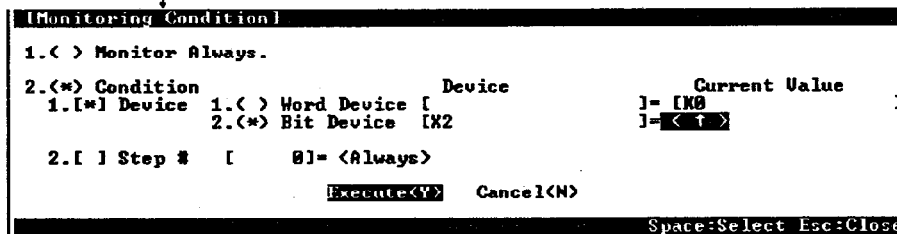

"Monitoring Condition screen (after setting)"

[Y] Monitor with detailed conditions

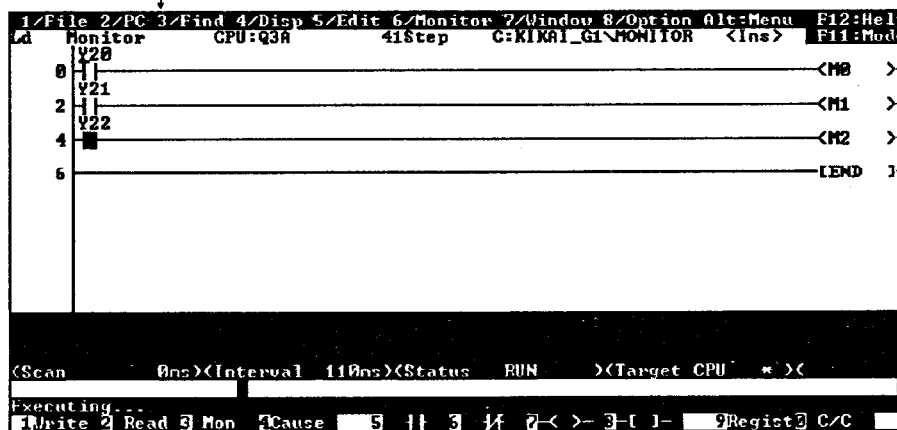

"Ladder Monitor screen"

4. MAKING THE MOST OF YOUR QnACPU (1)

4.6 Programming

4.6.1 Creating one program

This section shows how to create a program for the imaginary system below.

	X00 to X0F	X10 to X1F	Y20 to Y2F	Y30 to Y3F	X/Y40 to X/Y5F	X/Y60 to X/Y7F
A62P	Q3ACPU	AX40	AX40	AY40	AY40	A68AD A62DA

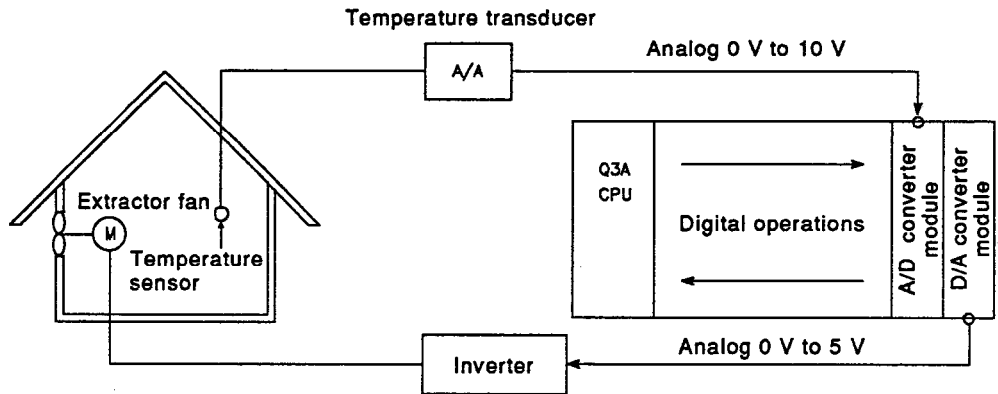

This system maintains a constant temperature in the cabin.

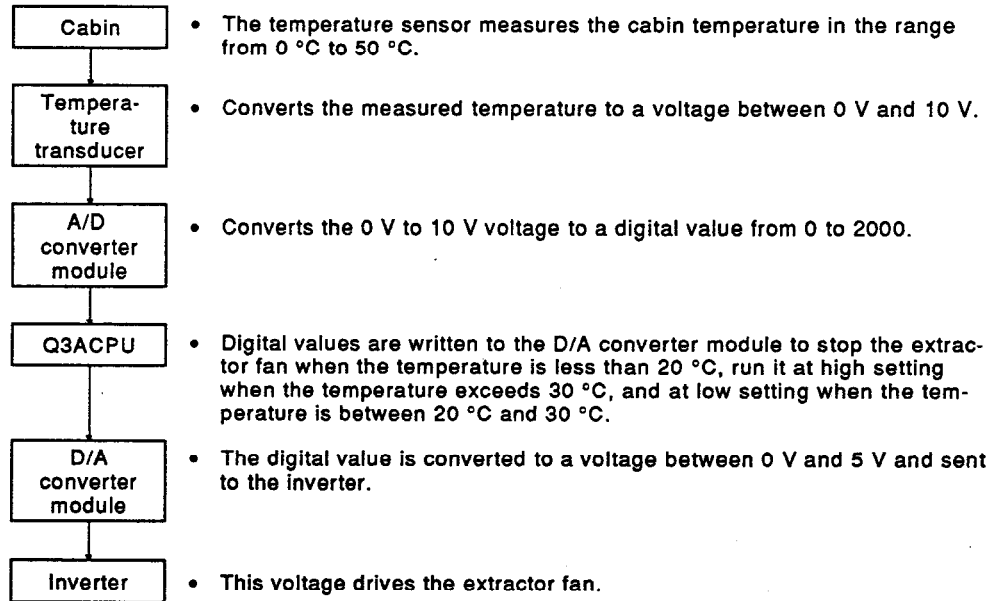

Allocation of devices used

- X0 Stop switch
- X41 A/D converter READY signal
- D0 Stores cabin temperature
- X61 D/A converter READY signal
- Y20 to Y2F... Cabin temperature display

4. MAKING THE MOST OF YOUR QnACPU (1)

(1) Create temperature regulation program

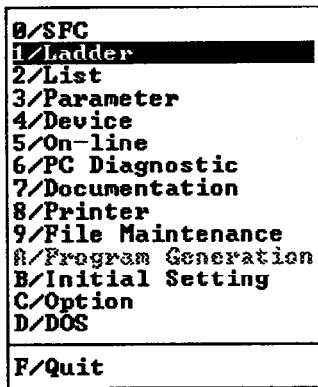

"Mode Select screen"

[1] Select "Ladder"

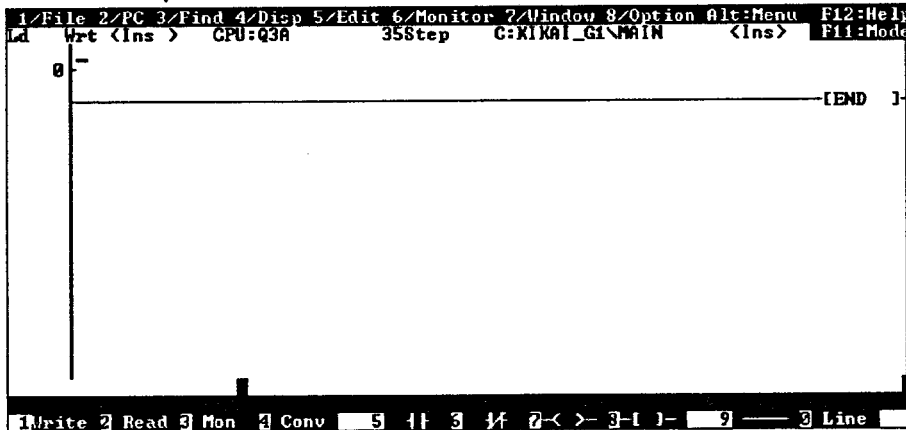

"Ladder write screen (before programming)"

[Ins] Change Write (insert) to Write (overwrite)
 [F6] [X] [0] [Enter] [F5] [X] [4] [1] [Enter] " ~~X0~~ ~~X14~~ " Write
 (#) (-+)
 [F8] [/] [SP] [U] [4] [N] [G] [1] [1] [SP]
 (-+)
 [K] [4] [0] [SP] [D] [0] [Enter] " ~~[/~~ ~~U4~~ ~~G1~~ K40 DO] " Write
 1)

4. MAKING THE MOST OF YOUR QnACPU (1)

MELSEC-QnA

1)

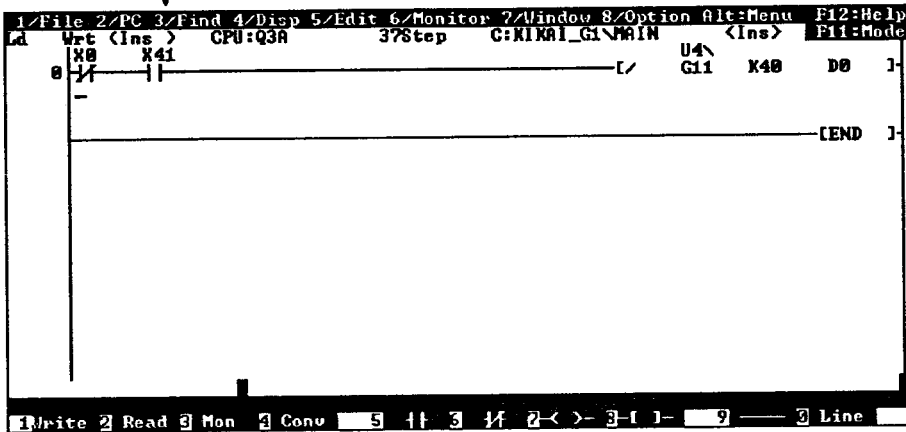

"Ladder Write screen (during programming)"

Continue this process to create the following ladder program.

[4] Convert

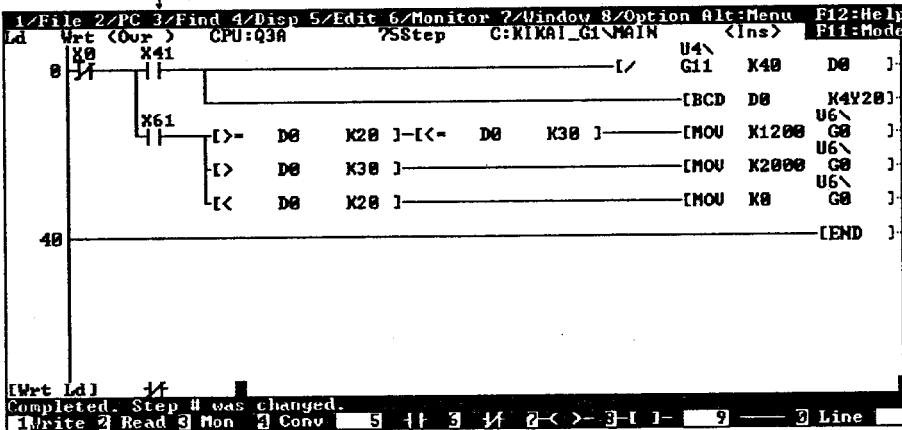

"Ladder Write screen (after programming)"

2)

4. MAKING THE MOST OF YOUR QnACPU (1)

(2) Write created program to file

2)

[Alt] [1] [2] Select "Write File"

```
Write File
1. Drive/Path [C:\GPPQ\USR ]
2. System [SYSTEM ] Title [ ]
3. Machine [MACHINE1] Title [ ]
4. File [MAIN ] Title [ ]
5. Target 1.[*] Parameter
          2.[*] Sequence/SFC Program
          3.[*] Device Comment
          Execute<Y> Cancel<N>
Ctrl+L:List Ctrl+D:Dir Space:Select Esc:Close
```

"Write File screen (before setting)"

[3] [BS] [BS] [BS] [BS] [BS] [BS] [BS] [BS]

[P] [R] [O] [G] [R] [A] [M] [Enter] Change machine name to "PROGRAM"

[4] [BS] [BS] [BS] [BS] [T] [E] [M] [P] [Enter] Change file name to "TEMP"

[5] [1] [3] Change write object to sequence program

```
Write File
1. Drive/Path [C:\GPPQ\USR ]
2. System [SYSTEM ] Title [ ]
3. Machine [PROGRAM ] Title [ ]
4. File [TEMP ] Title [ ]
5. Target 1.[*] Parameter
          2.[*] Sequence/SFC Program
          3.[*] Device Comment
          Execute<Y> Cancel<N>
Ctrl+L:List Ctrl+D:Dir Space:Select Esc:Close
```

"File Write screen (after setting)"

[Y] Write file

```
The machine name doesn't exist.
Do you want to create it?
Yes<Y> No<N>
```

[Y] Create new machine name

3)

4. MAKING THE MOST OF YOUR QnACPU (1)

MELSEC-QnA

3)

The screenshot shows a ladder logic editor window. The title bar includes menu options: 1/File, 2/PC, 3/Find, 4/Disp, 5/Edit, 6/Monitor, 7/Window, 8/Option, Alt:Menu, F12:Help. The main area displays a ladder logic program with the following instructions:

```

0  X8 X41 [BCD D0 K40 D0 ]
      |
      |---[MOU K1200 U6\ G0 ]
      |
      |---[MOU K2000 U6\ G0 ]
      |
      |---[MOU X0 U6\ G0 ]
      |
      |---[END ]
  
```

At the bottom of the window, a status bar shows: [Wrt Ld] [F11] Completed. Step # was changed. [Write] [Read] [Mon] [Conv] [5] [1] [3] [4] [0] [1] [2] [Line]

"Ladder Write screen"

[F11] Display mode select screen

4)

4.6.2 Creating multiple programs

This section shows how to create a program to add extra functions to the system described in section 4.6.1.

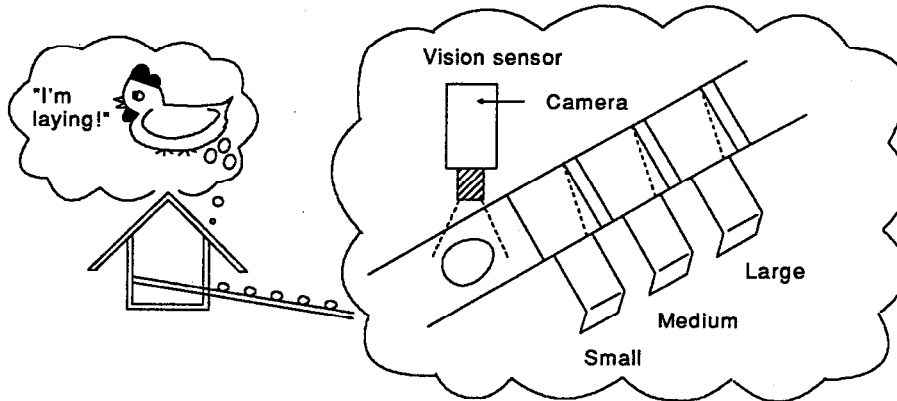

Classifies the eggs laid by the chickens into small, medium, and large sizes, and packs them as tens into boxes.

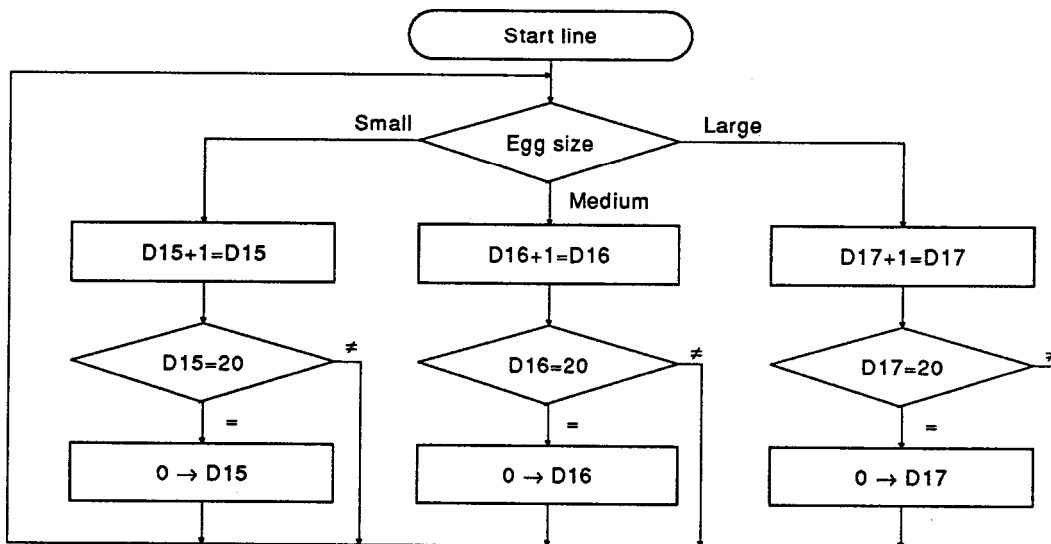

Allocation of devices used

- X10... Line start switch
- X11... Line stop switch
- Y30... Line start output
- M15... Small egg counter sensor
- M16... Medium egg counter sensor
- M17... Large egg counter sensor
- Y32... Extract small eggs
- Y33... Extract medium eggs
- Y34... Extract large eggs
- M10... Line start internal relay
- M11... Line stop internal relay
- D15... Number of small eggs storage
- D16... Number of medium eggs storage
- D17... Number of large eggs storage
- Y35... Change to small egg pack
- Y36... Change to medium egg pack
- Y37... Change to large egg pack

(1) Create size-selection program

4)

```

0/SFC
1/Ladder
2/List
3/Parameter
4/Device
5/On-line
6/PC Diagnostic
7/Documentation
8/Printer
9/File Maintenance
0/Program Generation
B/Initial Setting
C/Option
D/DOS

F/Quit
    
```

"Mode Select screen"

[B] Select "Initial Setting"

```

[Initial Setting]
1. Create...
2. Reads New Fl...
3. New from PC...
4. Close file...
5. PC Type Chg...

Esc:Close
    
```

"Initial Setting screen"

POINT
 The program created in Section 4.6.1 remains because up to four programs can be created simultaneously with the GPP.

[1] Select "Create..."

```

[Create]
1.< > Q2A
2.< > Q2AS1
3.<=> Q3A
4.< > Q4A

5.< > Xtype

Execute<Y> Cancel<N>

Space>Select Esc:Close
    
```

"Create screen"

[3] [Y] Select "Q3A"

5)

5)
 ↓
 Do you want to execute File Setting?
 Yes<Y> No<N>

[N]

```

0/SFC
1/Ladder
2/List
3/Parameter
4/Device
5/On-line
6/PC Diagnostic
7/Documentation
8/Printer
9/File Maintenance
A/Program Generation
B/Initial Setting
C/Option
D/DOS

F/Quit 2)
    
```

"Mode Select screen"

[1] Select "Ladder"

```

1/File 2/PC 3/Find 4/Disp 5/Edit 6/Monitor 7/Window 8/Option Alt+Menu F12:Help
d. Wrt <Ins> CPU:Q3A 35Step C:MKRA1_G2\MAIN <Ins> F11:Mode
0 - [END ]
    
```

```

1 Write 2 Read 3 Mon 4 Conv 5 11 3 14 7 < > 3 f 1 - 9 - 2 Line
    
```

"Ladder Write screen (before programming)"

[Ins] Change Write (insert) to Write (overwrite)
 [F5] [Shift] + [F7] [X] [1] [0] [Enter] " X10 " Write
 (-H) (↑)
 [F8] [S] [E] [T] [SP] [M] [1] [0] [Enter] " [SET M10] " Write
 (-L)

6)

4. MAKING THE MOST OF YOUR QnACPU (1)

6)



"Ladder Write screen (during programming)"

Continue this process to create the following ladder program.
[F4] Convert

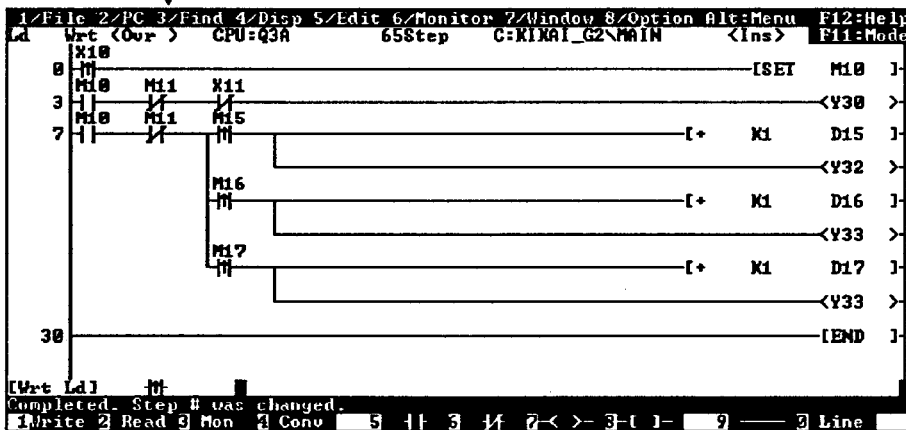

"Ladder Write screen (after programming)"

- (2) Set the file name to "SIZE" and write the file.
The operation is the same as described in Section 4.6.1(2).
- (3) Write program to the CPU.
See Section 3.5.2 for details about the write operation.

(4) Create the packing program

```

0/SFC
1/Ladder
2/List
3/Parameter
4/Device
5/On-line
6/PC Diagnostic
7/Documentation
8/Printer
9/File Maintenance
A/Program Generation
B/Initial Setting
C/Option
D/DOS

F/Quit
    
```

"Mode Select screen"

[B] Select "Initial Setting"

```

[Initial Setting]
1. Create...
2. Reads New Fl...
3. New from PC...
4. Close file...
5. PC Type Chg...

Esc:Close
    
```

"Initial Setting screen"

[1] Select "Create..."

```

[Create]
1.< > Q2A
2.< > Q2AS1
3.< > Q3A
4.< > Q4A

5.< > Xtype

Execute<Y>   Cancel<N>

Space:Select Esc:Close
    
```

"Create screen"

[3] [Y] Select "Q3A"

1)

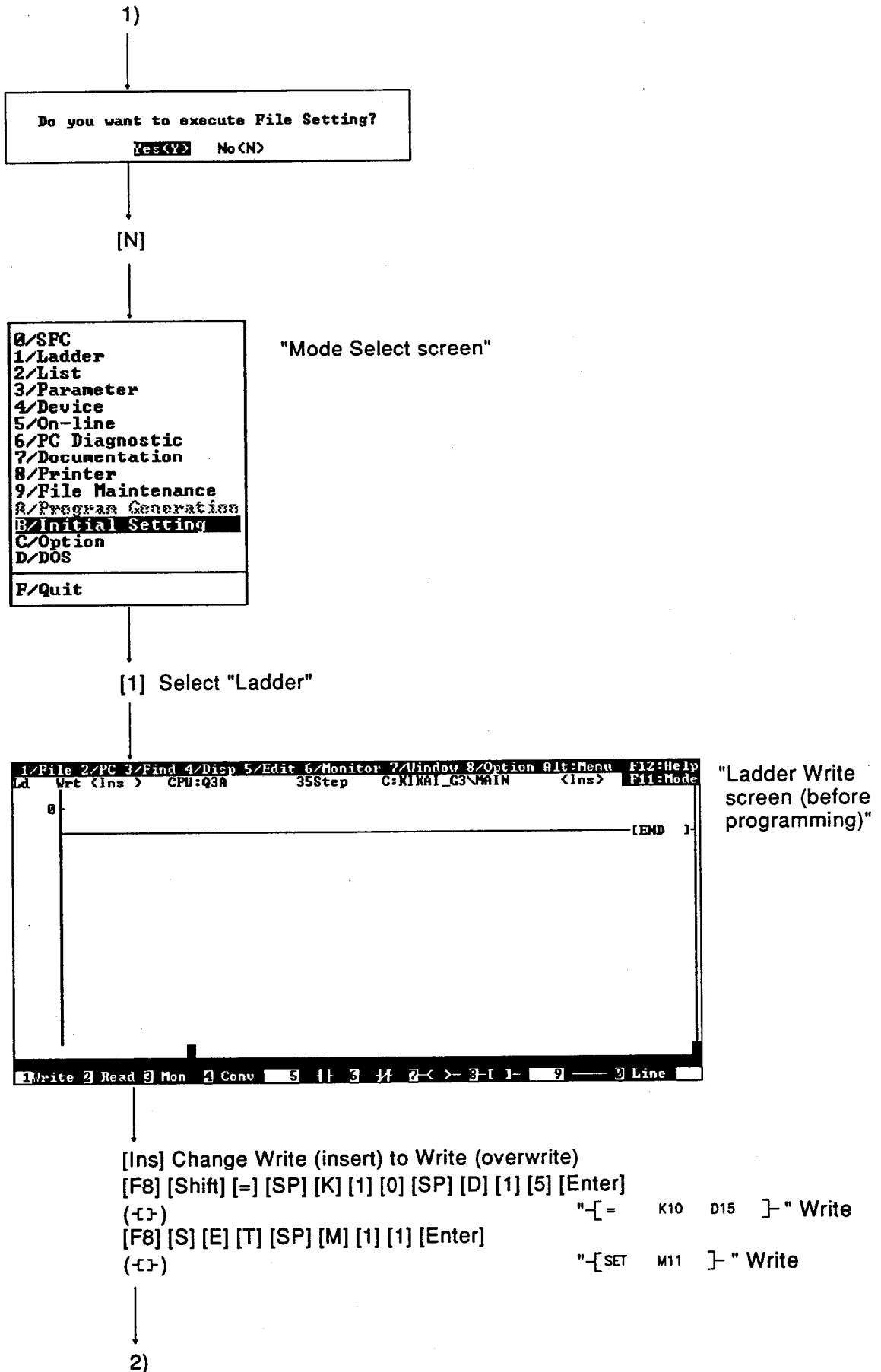

2)

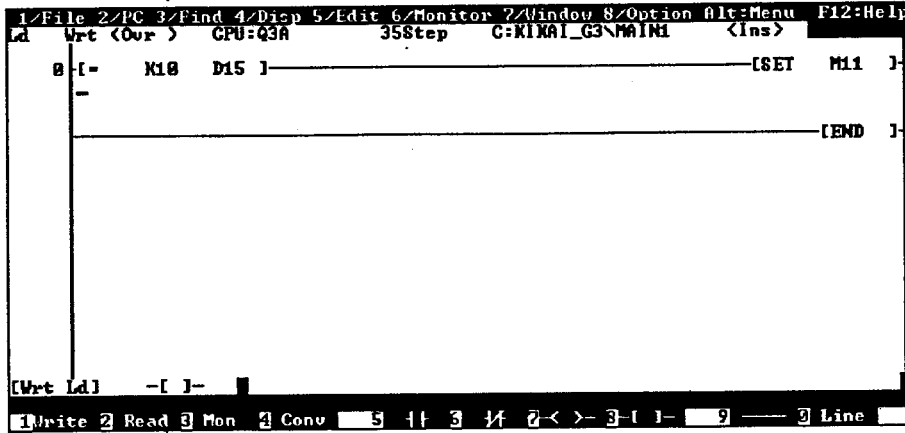

"Ladder Write screen (during programming)"

Continue this process to create the following ladder program
[F4] Convert

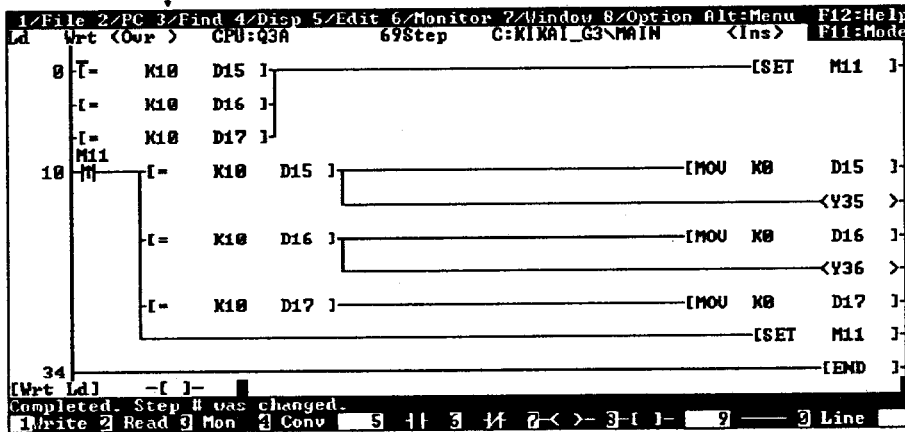

"Ladder Write screen (after programming)"

- (5) Set the file name to "PACKING" and write the file.
The operation is the same as described in Section 4.6.1 (2).
- (6) Write program to the CPU.
See Section 3.5.2 for details about the write operation.

(7) Set parameters

```

0/SFC
1/Ladder
2/List
3/Parameter
4/Device
5/On-line
6/PC Diagnostic
7/Documentation
8/Printer
9/File Maintenance
A/Program Generation
B/Initial Setting
C/Option
D/DOS

F/Quit
    
```

"Mode Select screen"

[3] Select "Parameter"

```

[Parameter] Label :
Current Status
1.(*) PC Name Definition None
2.< > PC System Setting Default
3.< > PC File Setting Default
4.< > Device Setting Default
5.< > PC RAS Setting Default
6.< > I/O Allocation None
7.< > MELSECNETII./10 Setting None
8.< > MELSECNET/MINI Setting None
9.< > Auxiliary Setting None
A.< > SFC Default

B.< > X/Y Allocation Confirm

Execute<Y> Cancel<N>

Space>Select Esc:Close
    
```

"Parameter screen (before setting)"

[9] Select "Auxiliary Setting"

```

[Parameter] Label :
Current Status
1.< > PC Name Definition None
2.< > PC System Setting Default
3.< > PC File Setting Default
4.< > Device Setting Default
5.< > PC RAS Setting Default
6.< > I/O Allocation None
7.< > MELSECNETII./10 Setting None
8.< > MELSECNET/MINI Setting None
9.(*) Auxiliary Setting None
A.< > SFC Default

B.< > X/Y Allocation Confirm

Execute<Y> Cancel<N>

Space>Select Esc:Close
    
```

"Parameter screen (after setting)"

[Y]

1)

1)

[Auxiliary Setting]	
1.<*> Program	Current Status
2.<> Boot	None
	None
Execute<V>	Cancel<N>
Space>Select Esc:Close	

"Auxiliary Setting screen"

[1] [Y] Select "Program"

[Program Setting]Label :		
#	Program	Execute
1	[]	< >
2	[]	< >
3	[]	< >
4	[]	< >
5	[]	< >
6	[]	< >
7	[]	< >
8	[]	< >
9	[]	< >
10	[]	< >
11	[]	< >
12	[]	< >
PgUp:Prev PgDn:Next Esc:Close		

"Program Setting screen (before setting)"

[T] [E] [M] [P] [Tab] [Enter]
 [S] [I] [Z] [E] [Tab] [Enter]
 [P] [A] [C] [K] [I] [N] [G] [Tab] [Enter]

Set program name "TEMP"
 as a scan program
 Set program name "SIZE"
 as a scan program
 Set program name "PACKING"
 as a scan program

[Program Setting]Label :		
#	Program	Execute
1	[TEMP]	<Scan>
2	[SIZE]	<Scan>
3	[PACKING]	<Scan>
4	[]	< >
5	[]	< >
6	[]	< >
7	[]	< >
8	[]	< >
9	[]	< >
10	[]	< >
11	[]	< >
12	[]	< >
PgUp:Prev PgDn:Next Esc:Close		

"Program Setting screen (after setting)"

[Esc]

2)

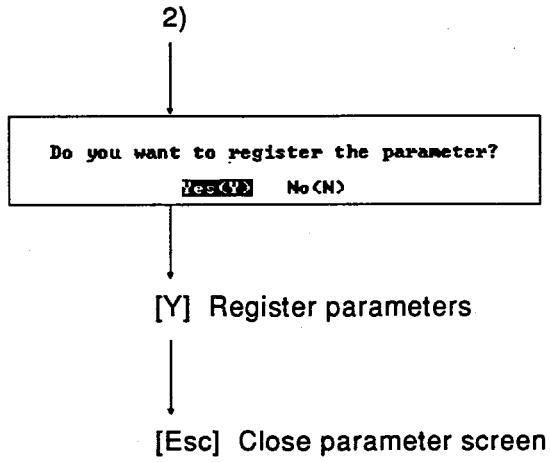

(8) Write to CPU.
See Section 4.2.2.

5. MAKING THE MOST OF YOUR QnACPU (2)

5.1 Programming Before I/O Module Configuration is Determined

By adding labels to the sequence program, a QnACPU program can be created before the I/O module configuration is determined.

5.1.1 Programming using labels

The example shown below is used to explain programming with labels.

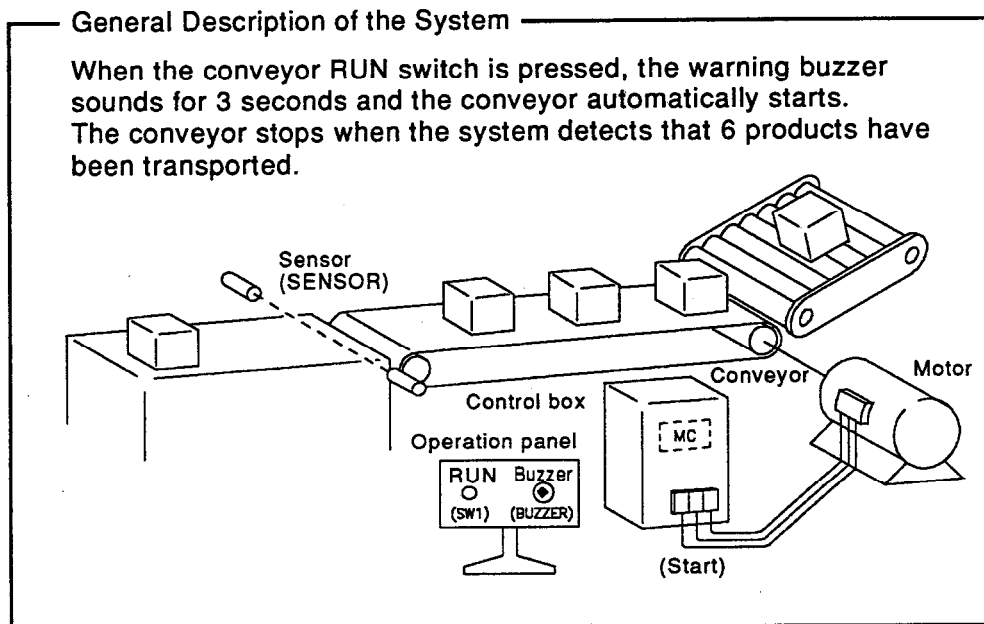

5. MAKING THE MOST OF YOUR QnACPU (2)

(1) Create the sequence program using the labels below.

Label	Device	Comment
SW1	X0	Operation command for conveyor
COUNT	C0	6-product product count
OPERATION	M0	Operation in progress
START	Y71	Operation start command
BUZZER	Y70	Operation start buzzer
TIMER	T0	3 second timer for buzzer
SENSOR	X1	Product detection

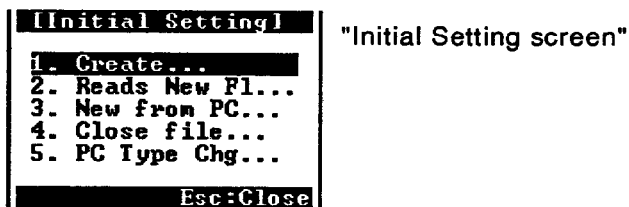

[1] Select "Create..."

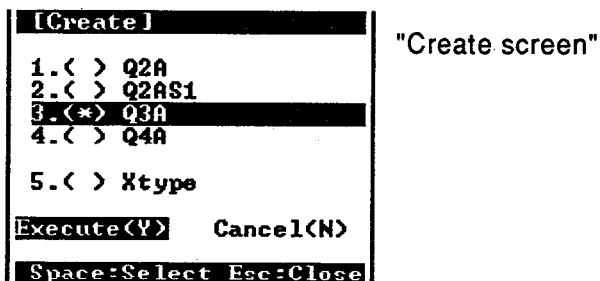

[5] [Y] Select PC type "Xtype"

1)

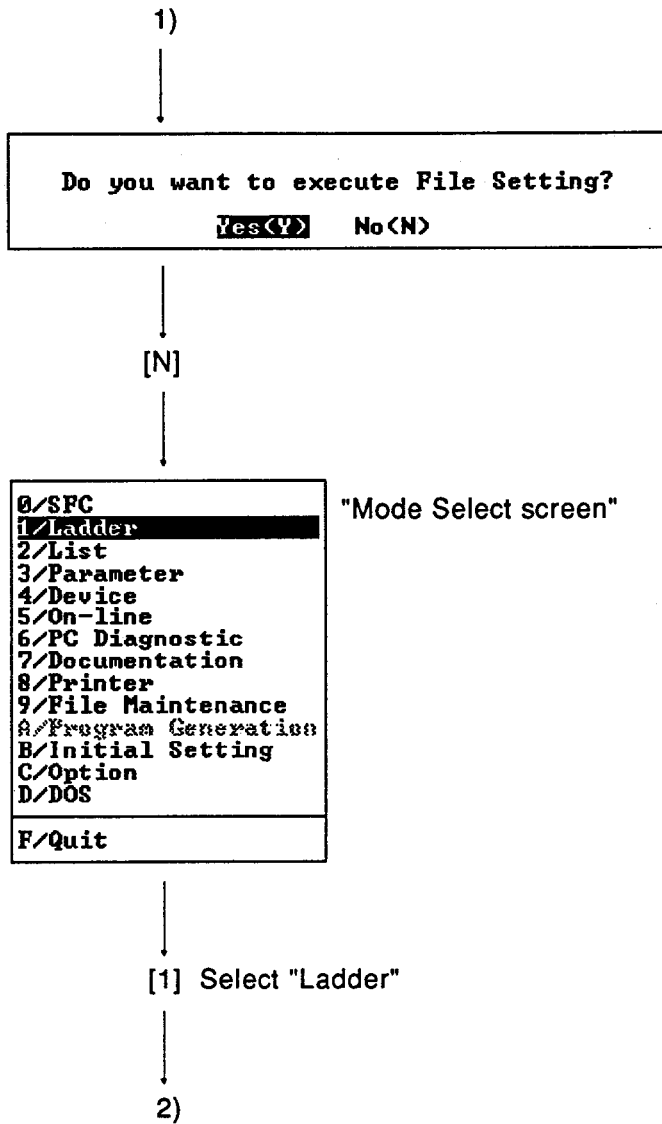

5. MAKING THE MOST OF YOUR QnACPU (2)

MELSEC-QnA

2)

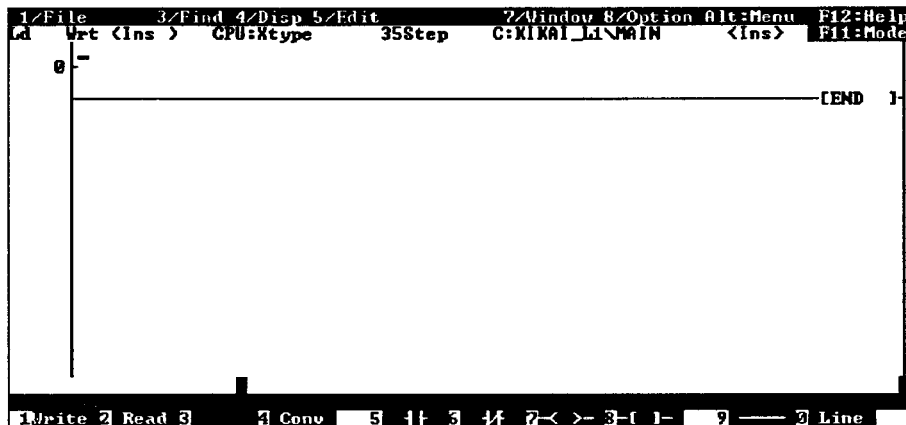

"Ladder Write screen (before programming)"

POINT

To define a label, insert an apostrophe (') at the beginning.

[F5]+[Shift] ['] [S] [W] [1] [Enter]
(←)

[F6]+[Shift] ['] [C] [O] [U] [N] [T] [Enter]
(←)

[F7]+[Shift] ['] [O] [P] [E] [R] [A] [T] [I] [O] [N] [Enter]
(←)



"Ladder Write screen (during programming)"

3)

3)

Continue this process to create the following ladder program.

[F4] Convert

```

1/ File  3/ Find 4/ Disp 5/ Edit  7/ Window 8/ Option Alt: Menu  F12: Help
Ld  Vrt <Ins>  CPU:Ktype  69Step  C:KIKAI_LINMAIN  <Ins>  F11: Mode
0  | SWI  'COUNT  <'OPERATION  >
  | OPERATION  <'BUZZER  >
  | OPERATION  'START  <'TIMER  >
14 | | 'K30  <'START  >
  | | 'K6  <'COUNT  >
20 | | START  [RST  'COUNT  ]
24 | |  [END  ]
30 | |
34 | |
[Ins Ld]  |
Completed. Step # was changed.
Write 2 Read 3 Conv 5 1 3 1 2 < > 3 1 9 2 Line
    
```

"Ladder Write screen (after programming)"

[F11] Select "Mode"

4)

(3) Write the program to file

6)

[Alt] [1] [2] Select "Write File"

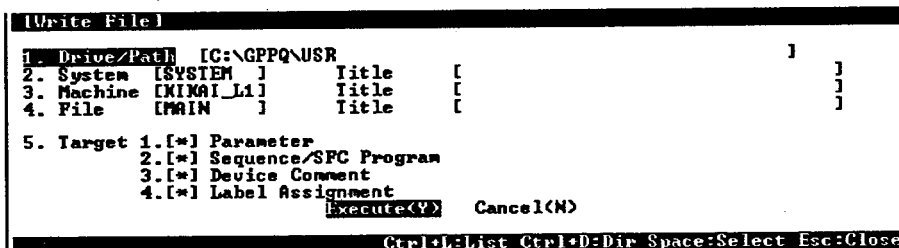

"Write File screen (before setting)"

[3] [BS] [BS] [BS] [BS] [BS] [BS] [BS] [BS] [X] [T] [Y] [P] [E] [Enter]
Change machine name to "XTYPE"

[4] [BS] [BS] [BS] [BS] [L] [A] [B] [E] [L] [Enter]
Change file name to "LABEL"

[5] [1] Change write object to sequence program and device comment.

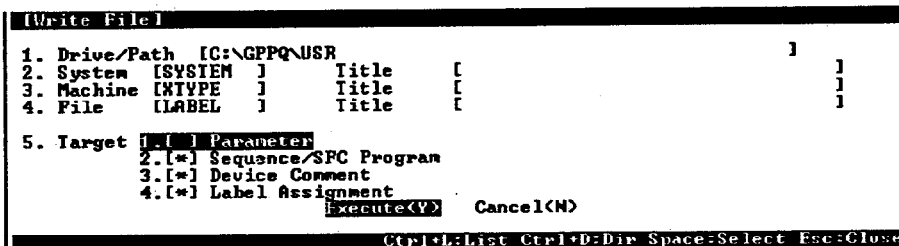

"Write File screen (after setting)"

[Y] Write file Execte

7)

(4) Expand general-purpose program to an actual program

8)

[Alt] [2] Select "Program Generation"

```

1/Program Expansion...
2/File Merging...
3/Program Expansion & Merge...
4/Option...
    
```

"Program Generation screen"

[1] Select "Program Expansion"

```

[Program Expansion]
1. Object to be Expanded  1.[*] Sequence, SFC Program
                          2.[*] Label -> Device Comment
2. Exp Dst   Path          System   Machine  File
   [C:\GPPQ\USR          ][SYSTEM ][           ][           ]
3. Ref Macro Path         System   Machine
   [C:\GPPQ\USR          ][SYSTEM ][IXTYPE  ]
Execute<Y>   Cancel<N>
Ctrl+L:List Ctrl+D:Dir Space:Select Esc:Close
    
```

"Program Expansion screen (before setting)"

[2] [Tab] [Tab]
 [Q] [3] [A] [Tab]
 [L] [A] [B] [E] [L] [Enter] Change machine name and file name

```

[Program Expansion]
1. Object to be Expanded  1.[*] Sequence, SFC Program
                          2.[*] Label -> Device Comment
2. Exp Dst   Path          System   Machine  File
   [C:\GPPQ\USR          ][SYSTEM ][Q3A   ][LABEL  ]
3. Ref Macro Path         System   Machine
   [C:\GPPQ\USR          ][SYSTEM ][IXTYPE  ]
Execute<Y>   Cancel<N>
Ctrl+L:List Ctrl+D:Dir Space:Select Esc:Close
    
```

"Program Expansion screen (after setting)"

[Y]

9)

9)
Machine name doesn't exist.
Do you want to create machine ExpDst?
Yes<Y> No<N>

[Y]

```
[PC Type Setting]
Path   C:\GPPQ\USR
System SYSTEM
Machine Q3A
1. PC Type < Q2A >
Execute<Y> Cancel<N>
Space:Select Esc:Close
```

"PC Type Setting screen (before setting)"

[SP] [SP] [SP] Select PC type "Q3A"

```
[PC Type Setting]
Path   C:\GPPQ\USR
System SYSTEM
Machine Q3A
1. PC Type < Q3A >
Execute<Y> Cancel<N>
Space:Select Esc:Close
```

"PC Type Setting screen (after setting)"

[Y]

10)

5. MAKING THE MOST OF YOUR QnACPU (2)

MELSEC-QnA

(5) Read the expanded program

11)

[Alt] [1] [1] Select "Read File"

[Read File]						
Drive/Path :C:\GPPQ\USR						
System :SYSTEM Title :						
Machine:XTYPE Title :						
File	Type	Size	Date	Time	Title	
PARAM	Parameter	330	96-05-13	12:57	:	
LABEL	Xtype Seq	243	96-05-13	18:22	:	
LABEL	Label	362	96-05-13	18:22	:	
File(s): 3 Free 106061824Byte(s) Execute(Y) Cancel(N)						
PgUp:Prev PgDn:Next			Ctrl+D=Dir Space>Select Esc=Close			

"Read File screen"

[Ctrl]+[D] Directory display

[Read File]						
Drive/Path IC:\GPPQ\USR						
PC Type Title 1						
LIB :						
SYSTEM	:	:	:	:	:	
--- MIXAI_G1	Q3A	:	:	:	:	
--- MIXAI_G2	Q3A	:	:	:	:	
--- PROGRAM	Q3A	:	:	:	:	
--- MIXAI_L1	Xtype	:	:	:	:	
--- MIXAI_G3	Q3A	:	:	:	:	
--- XTYPE	Xtype	:	:	:	:	
--- Q3A	Q3A	:	:	:	:	
--- HANYOU	Xtype	:	:	:	:	
--- SYS	:	:	:	:	:	
--- SAMPLE	Q3A	:	:	:	:	
System(s) 4 Machine(s) 15 Free 106061824Byte(s) Execute(Y) Cancel(N)						
PgUp:Prev PgDn:Next			Ctrl+P=Path Space>Select Esc=Close			

"Read File screen
(directory display)"

[↓][↓][↓][↓][↓][↓][↓][↓][Y] Select machine name "Q3A"

12)

12)

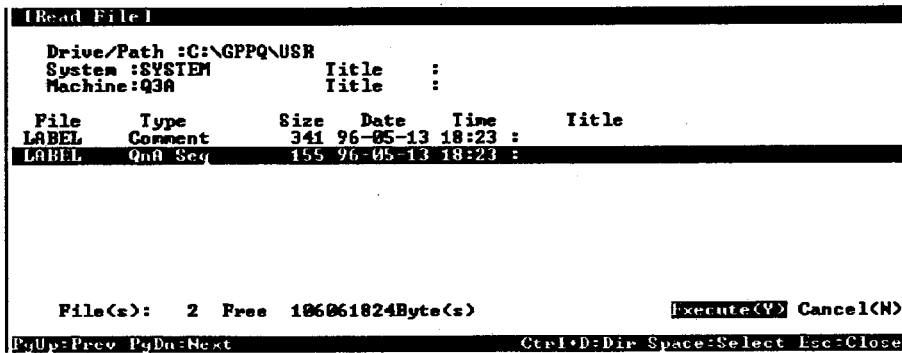

"Read File screen"

[SP] [Y] Select file name "LABEL"

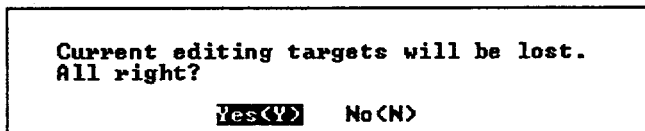

[Y]

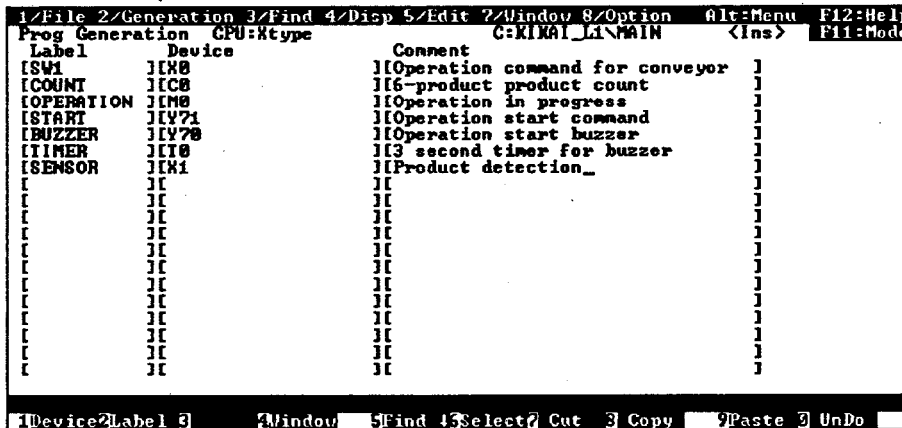

"Program Generation screen"

[F11] Display "Mode Select screen"

13)

5.2 Utilizing Program Resources

5.2.1 Program standardization with user-created macros

Macro instructions are instructions which read and utilize ladders pre-saved in a peripheral device. Using macro instructions improves program productivity. This section describes how to use the macro instructions.

- (1) Create the following sequence program and write it to file

```

1/File 2/PC 3/Find 4/Disp 5/Edit 6/Monitor 7/Window 8/Option Alt:Menu F12:Help
Ld Wrt (Ins) CPU:Q3A 45Step C:Q3A\MAIN (Ins) F11:Mode
0 [T] D1 D2 1-----[MOU D1 D3 ]
5 [K= D1 D2 1-----[MOU D2 D3 ]
10 -----[END ]

[Ins Ld] -[ ]-
Completed. Step # was changed.
1 Write 2 Read 3 Mon 4 Conv 5 6 7 8 9 0 < > - 1 - 2 Line
    
```

"Ladder Write screen (before programming)"

- (2) Read the file and register the macro

```

1/File 2/PC 3/Find 4/Disp 5/Edit 6/Monitor 7/Window 8/Option Alt:Menu F12:Help
Ld Wrt (Ins) CPU:Q3A 45Step C:Q3A\MAIN (Ins) F11:Mode
0 [T] D1 D2 1-----[MOU D1 D3 ]
5 [K= D1 D2 1-----[MOU D2 D3 ]
10 -----[END ]

[Ins Ld] -[ ]-
1 Write 2 Read 3 Mon 4 Conv 5 6 7 8 9 0 < > - 1 - 2 Line
    
```

"Ladder Write screen"

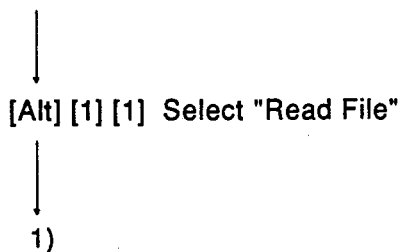

1)

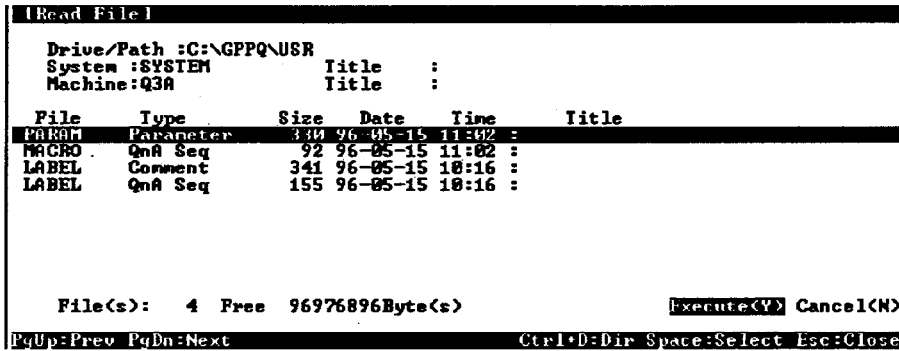

"Read File screen (before setting)"

[↓] [SP] Select file name "MACRO"

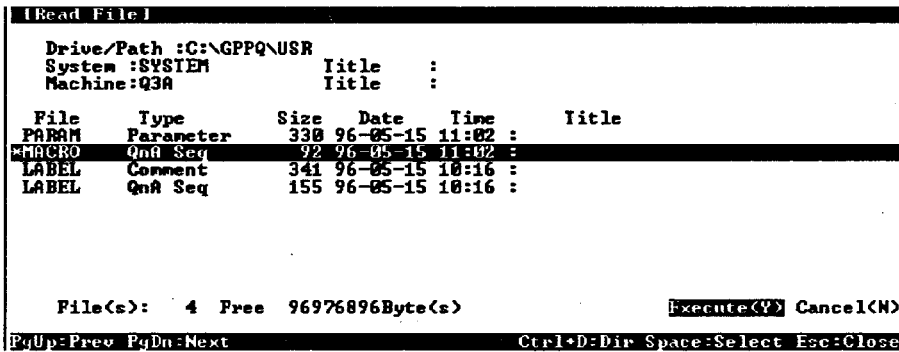

"Read File screen (after setting)"

[Y]

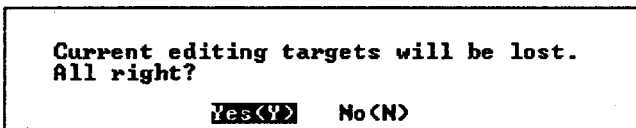

[Y]

2)

2)

Do you want to change file name to that is read?
 Yes<Y> No<N>

[Y]

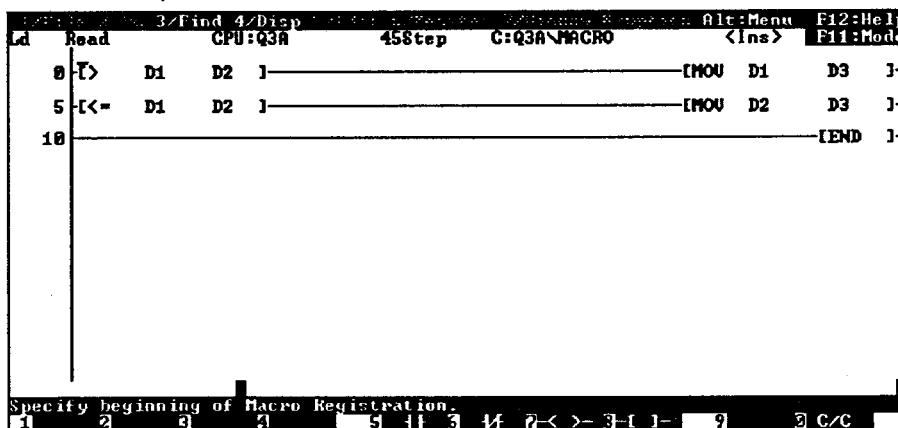

"Ladder Read screen"

[Alt] [1] [8] Select "Macro Registration"

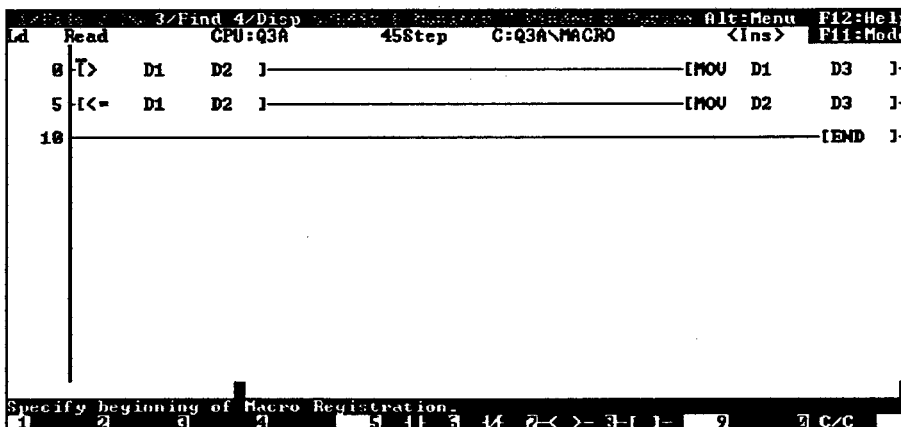

"Ladder Read screen (designate macro registration destination)"

[Enter] Designate step 0 as beginning of Macro Registration destination

3)

3)

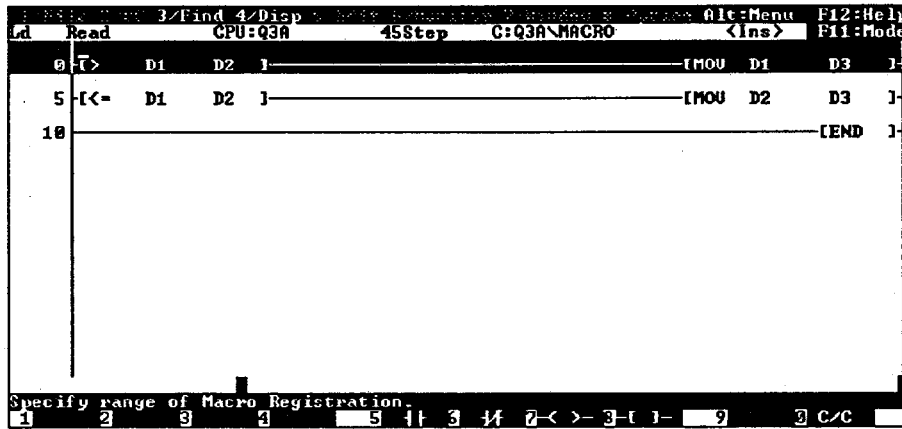

"Ladder Read screen (designate macro registration range)"

[↓] Designate the macro registration range up to step 9

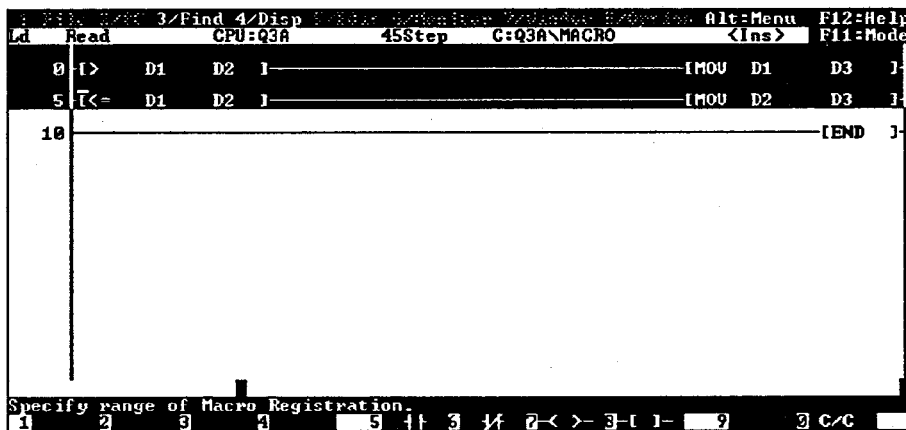

"Ladder Read screen (designate macro registration range)"

[Enter] Enter macro registration range

4)

4)

```

[Macro Registration]
      Device Name      Comment(Statement)
1. UD0:[              ] [              ]
2. UD1:[              ] [              ]
3. UD2:[              ] [              ]
4. UD3:[              ] [              ]
5. UD4:[              ] [              ]

Execute(Y)  Cancel(N)

Space:Select Esc:Close
    
```

"Macro Registration screen (before setting)"

- [1] [D] [1] [Enter] [Enter] Set D1 as VD0
- [2] [D] [2] [Enter] [Enter] Set D2 as VD1
- [3] [D] [3] [Enter] [Enter] Set D3 as VD2

POINT
A maximum of five variable devices (VD) can be set.

```

[Macro Registration]
      Device Name      Comment(Statement)
1. UD0:[D1           ] [Number of product A  ]
2. UD1:[D2           ] [Number of product B  ]
3. UD2:[D3           ] [Maximum number of products]
4. UD3:[             ] [              ]
5. UD4:[             ] [              ]

Execute(Y)  Cancel(N)

Space:Select Esc:Close
    
```

"Macro Registration screen (after setting)"

[Y]

```

[Macro Registration]
1. Drive/Path [C:\GPPQ\USR ]
2. System [SYSTEM ] Title [ ]
3. Machine [Q3A ] Title [ ]
4. File [MACRO ] Title [ ]

Execute(Y)  Cancel(N)

Ctrl+L:List Ctrl+D:Dir Space:Select Esc:Close
    
```

"Write File screen (before setting)"

[4] [BS] [BS] [0] [1] [Enter]
Select file name "MAC01"

5)

5)

```
[Macro Registration]
1. Drive/Path [C:\GPPQ\USR ]
2. System [SYSTEM ] Title [ ]
3. Machine [Q3A ] Title [ ]
4. File [MAC01 ] Title [ ]
Execute<Y> Cancel<N>
Ctrl+L:List Ctrl+D:Dir Space:Select Esc:Close
```

" Write File
screen (after
setting)"

[Y]

[F1] Select "Ladder Write"

6)

5. MAKING THE MOST OF YOUR QnACPU (2)

MELSEC-QnA

(3) Read a registered macro file and utilize the macro.

6)

```

CPU:Q3A      45Step      C:Q3A\MACRO      <Ins>
Ld  Head
0  T>  D1  D2  1-----[MOU D1  D3  1-
5  [<=  D1  D2  1-----[MOU D2  D3  1-
10 -----[END  ]-
Specify beginning of Macro Registration.
1  2  3  4  5  6  7  8  9  0  C/C
    
```

"Ladder Write screen"

[Alt] [1] [9] Select "Use Macro"

```

[Use Macro]
Drive/Path :C:\GPPQ\USR
System :SYSTEM      Title :
Machine:Q3A        Title :
File      Type      Size  Date   Time  Title
MAC01    Q Macro    383  96-05-13 19:47 :
File(s):  1 Free 107347968Byte(s)  Execute(Y) Cancel(N)
PgUp:Prev PgDn:Next      Ctrl+D:Dir Space:Select Esc:Close
    
```

"Read File screen (before setting)"

[SP] Select file "MAC01"

7)

5. MAKING THE MOST OF YOUR QnACPU (2)

7)

```

[Use Macro]
Drive/Path :C:\GPPQ\USR
System :SYSTEM
Machine:Q3R
Title :
Title :
File Type Size Date Time Title
MAC01 Q Macro 383 96-05-13 19:47 :
File(s): 1 Free 107347968Byte(s) Execute(Y) Cancel(N)
PgUp=Prev PgDn=Next Ctrl+D=Dir Space>Select Esc=Close
    
```

"Read File screen (after setting)"

[Y]

```

[Macro Use]
Device Name Comment(Statement)
1. VD0:[ ] Number of product A
2. VD1:[ ] Number of product B
3. VD2:[ ] Maximum number of products
4. First I/O Number U:[ ]
Execute(Y) Cancel(N)
Space>Select Esc=Close
    
```

"Macro Use screen (before setting)"

- [1] [D] [1] [0] [Enter] Set D10 as VD0
- [2] [D] [1] [1] [Enter] Set D11 as VD1
- [3] [D] [1] [2] [Enter] Set D12 as VD2
- [4] [0] [Enter] Set 0 as the first I/O number

8)

8)

```

[Macro Use]
Device Name      Comment(Statement)
1. UD0:[D10]     ] Number of product A
2. UD1:[D11]     ] Number of product B
3. UD2:[D12]     ] Maximum number of products
4. First I/O Number U:[ 0]

Execute(Y)  Cancel(N)
Space>Select Esc:Close
    
```

"Macro Use screen (after setting)"

[Y]

```

3/Find 4/Disp CPU:Q3A 45Step C:Q3A\MACRO <Ins> Alt+Menu F12:Help
Ld Read D1 D2 ]-----[MOU D1 D3 ]-
5 T(- D1 D2 ]-----[MOU D2 D3 ]-
10 -----[END ]-

Specify beginning of Using Macro.
1 2 3 4 5 6 7 8 9 0 C/C
    
```

"Ladder Write screen (before macro use)"

[↓] [Enter] Set step 10 as the first step to macro use

9)

5. MAKING THE MOST OF YOUR QnACPU (2)

9)

```

1/File 2/PC 3/Find 4/Disp 5/Edit 6/Monitor 7/Window 8/Option Alt:Menu F12:Help
Ld Read CPU:Q3A 196Step C:Q3A\MACRO <Ins> P11:Mode
0 [I] D1 D2 ]-----[MOU D1 D3 ]-
5 [K= D1 D2 ]-----[MOU D2 D3 ]-
10 [I] D10 D11 ]-----[MOU D10 D12 ]-
149 [K= D10 D11 ]-----[MOU D11 D12 ]-
154
161-----[END ]-
    
```

"Ladder Write screen (after macro use)"

[Alt] [4] [3] Turn on statement display (OFF→ON)

```

1/File 2/PC 3/Find 4/Disp 5/Edit 6/Monitor 7/Window 8/Option Alt:Menu F12:Help
Ld Read CPU:Q3A 196Step C:Q3A\MACRO <Ins> P11:Mode
0 [I] D1 D2 ]-----[MOU D1 D3 ]-
5 [K= D1 D2 ]-----[MOU D2 D3 ]-
;[ MACRO : MACRO1
;
UD0 = (Number of product A )
UD1 = (Number of product B )
UD2 = (Maximum number of products )
10 [I] D10 D11 ]-----[MOU D10 D12 ]-
149 [K= D10 D11 ]-----[MOU D11 D12 ]-
[MACROEND]
154
161-----[END ]-
    
```

"Ladder Write screen (with statement display ON)"

5. MAKING THE MOST OF YOUR QnACPU (2)

MELSEC-QnA

(4) Macro use with macro instruction "M. file name VD1 VD2 D3".

Read the file with file name "MACRO" from machine name "Q3A".

```

3/Find 4/Disp          Alt=Menu  F12:Help
Ld  Read      CPU:Q3A      45Step  C:Q3A\MACRO  <Ins>  F11:Mode
0  [ ]>  D1  D2  1-----[MOU  D1  D3  ]
5  [ ]<=  D1  D2  1-----[MOU  D2  D3  ]
10 -----[END  ]

Specify beginning of Macro Registration.
1  2  3  4  5  6  7  8  9  C/C
    
```

"Ladder Read screen"

[F1] Change Read to Write
[Alt] [1] [A] Select "Macro Ref Setting"

```

(Macro Ref Setting)
Drive/Path :C:\GPPQ\USR
System :SYSTEM      Title :
Machine:Q3A        Title :
File      Type      Size  Date   Time   Title
-----
MACRO1   Q Macro    383  96-05-13 19:47 :

File(s):  1 Free 107020288Byte(s)  Execute(Y) Cancel(N)
PgUp=Prev PgDn=Next          Ctrl+D=Dir Esc=Close
    
```

"Macro Ref Setting screen"

[Y]

10)

5. MAKING THE MOST OF YOUR QnACPU (2)

10)

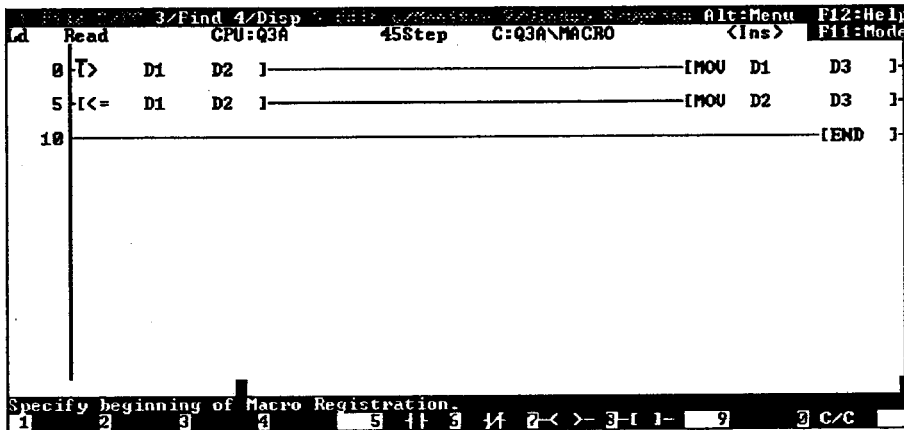

"Ladder Write screen (before macro use)"

[↓] [↓] [Shift]+[Ins] [M] [.] [M] [A] [C] [0] [1] [SP] [D] [1] [0] [SP] [D] [1] [1]
 [SP] [D] [1] [2] [Enter] Set step 10 as the first step to macro use
 "-[M.MAC01 D10 D11 D12]- " Write

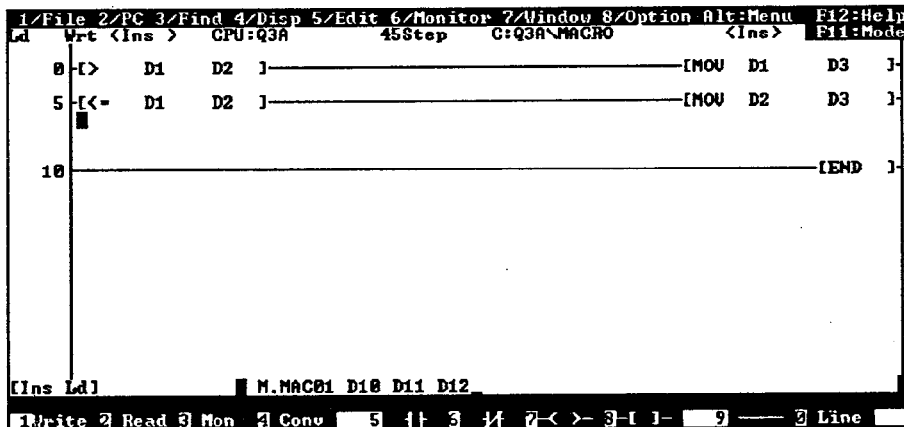

"Ladder Write screen (after macro use)"

[F4] Convert

11)

11)

```

1/File 2/PC 3/Find 4/Disp 5/Edit 6/Monitor 7/Window 8/Option Alt:Menu F12:Help
Ld Wrt <Ins> CPU:Q3A 196Step C:Q3A\MACRO <Ins> F11:Mode
0 [T] D1 D2 ]-----[MOU D1 D3 ]
5 [L< D1 D2 ]-----[MOU D2 D3 ]
10 [T] D10 D11 ]-----[MOU D10 D12 ]
149 [L< D10 D11 ]-----[MOU D11 D12 ]
154
161 -----[END ]
[Ins Ld] -[ ]-
Write 2 Read 3 Mon 4 Conv 5 6 7 8 9 Line
    
```

"Ladder Write screen (after conversion)"

[Alt] [4] [3] Turn on statement display (OFF→ON)

```

1/File 2/PC 3/Find 4/Disp 5/Edit 6/Monitor 7/Window 8/Option Alt:Menu F12:Help
Ld Wrt <Ins> CPU:Q3A 196Step C:Q3A\MACRO <Ins> F11:Mode
0 [T] D1 D2 ]-----[MOU D1 D3 ]
5 [L< D1 D2 ]-----[MOU D2 D3 ]
;[ MACRO : MACB1 ]
; UD0 = <Number of product A >
; UD1 = <Number of product B >
; UD2 = <Maximum number of products >
10 [T] D10 D11 ]-----[MOU D10 D12 ]
149 [L< D10 D11 ]-----[MOU D11 D12 ]
[MACROEND]
154
161 -----[END ]
Write 2 Read 3 Mon 4 Conv 5 6 7 8 9 Line
    
```

"Ladder Write screen (with statement display ON)"

QnACPU GUIDEBOOK

MODEL	QNACPU-G-E
MODEL CODE	13JF10
IB(NA)66606-A(9607)MEE	

 **MITSUBISHI ELECTRIC CORPORATION**

HEAD OFFICE : MITSUBISHI DENKI BLDG MARUNOUCHI TOKYO 100-0005 TELEX : J24532 CABLE MELCO TOKYO
NAGOYA WORKS : 1-14, YADA-MINAMI 5, HIGASHI-KU, NAGOYA, JAPAN

When exported from Japan, this manual does not require application to the Ministry of International Trade and Industry for service transaction permission.

Specifications subject to change without notice.

HEADQUARTERS

MITSUBISHI ELECTRIC EUROPE B.V. **EUROPE**
 German Branch
 Gothaer Straße 8
D-40880 Ratingen
 Phone: +49 (0)2102 / 486-0
 Fax: +49 (0)2102 / 486-1120

MITSUBISHI ELECTRIC EUROPE B.V.-org.sl. **CZECH REP.**
 Czech Branch
 Avenir Business Park, Radlická 714/113a
CZ-158 00 Praha 5
 Phone: +420 - 251 551 470
 Fax: +420 - 251-551-471

MITSUBISHI ELECTRIC EUROPE B.V. **FRANCE**
 French Branch
 25, Boulevard des Bouvets
F-92741 Nanterre Cedex
 Phone: +33 (0)1 / 55 68 55 68
 Fax: +33 (0)1 / 55 68 57 57

MITSUBISHI ELECTRIC EUROPE B.V. **IRELAND**
 Irish Branch
 Westgate Business Park, Ballymount
IRL-Dublin 24
 Phone: +353 (0)1 4198800
 Fax: +353 (0)1 4198890

MITSUBISHI ELECTRIC EUROPE B.V. **ITALY**
 Italian Branch
 Viale Colleoni 7
I-20041 Agrate Brianza (MB)
 Phone: +39 039 / 60 53 1
 Fax: +39 039 / 60 53 312

MITSUBISHI ELECTRIC EUROPE B.V. **POLAND**
 Poland Branch
 Krakowska 50
PL-32-083 Balice
 Phone: +48 (0)12 / 630 47 00
 Fax: +48 (0)12 / 630 47 01

MITSUBISHI ELECTRIC EUROPE B.V. **RUSSIA**
 52, bid. 3 Kosmodamianskaya nab 8 floor
RU-115054 Moscow
 Phone: +7 495 721-2070
 Fax: +7 495 721-2071

MITSUBISHI ELECTRIC EUROPE B.V. **SPAIN**
 Spanish Branch
 Carretera de Rubí 76-80
E-08190 Sant Cugat del Vallés (Barcelona)
 Phone: 902 131121 // +34 935653131
 Fax: +34 935891579

MITSUBISHI ELECTRIC EUROPE B.V. **UK**
 UK Branch
 Travellers Lane
UK-Hatfield, Herts. AL10 8XB
 Phone: +44 (0)1707 / 27 61 00
 Fax: +44 (0)1707 / 27 86 95

MITSUBISHI ELECTRIC CORPORATION **JAPAN**
 Office Tower "Z" 14 F
 8-12,1 chome, Harumi Chuo-Ku
Tokyo 104-6212
 Phone: +81 3 622 160 60
 Fax: +81 3 622 160 75

MITSUBISHI ELECTRIC AUTOMATION, Inc. **USA**
 500 Corporate Woods Parkway
Vernon Hills, IL 60061
 Phone: +1 847 478 21 00
 Fax: +1 847 478 22 53

EUROPEAN REPRESENTATIVES

GEVA **AUSTRIA**
 Wiener Straße 89
AT-2500 Baden
 Phone: +43 (0)2252 / 85 55 20
 Fax: +43 (0)2252 / 488 60

TEHNIKON **BELARUS**
 Oktyabrskaya 16/5, Off. 703-711
BY-220030 Minsk
 Phone: +375 (0)17 / 210 46 26
 Fax: +375 (0)17 / 210 46 26

ESCO DRIVES & AUTOMATION **BELGIUM**
 Culliganlaan 3
BE-1831 Diegem
 Phone: +32 (0)2 / 717 64 30
 Fax: +32 (0)2 / 717 64 31

Koning & Hartman b.v. **BELGIUM**
 Woluwelaan 31
BE-1800 Vilvoorde
 Phone: +32 (0)2 / 257 02 40
 Fax: +32 (0)2 / 257 02 49

INEA BH d.o.o. **BOSNIA AND HERZEGOVINA**
 Aleja Lipa 56
BA-71000 Sarajevo
 Phone: +387 (0)33 / 921 164
 Fax: +387 (0)33 / 524 539

AKHNATON **BULGARIA**
 4 Andrej Ljapchev Blvd. Pb 21
BG-1756 Sofia
 Phone: +359 (0)2 / 817 6044
 Fax: +359 (0)2 / 97 44 06 1

INEA CR d.o.o. **CROATIA**
 Losinjska 4 a
HR-10000 Zagreb
 Phone: +385 (0)1 / 36 940 -01 / -02 / -03
 Fax: +385 (0)1 / 36 940 -03

AutoCont C.S. s.r.o. **CZECH REPUBLIC**
 Technologická 374/6
CZ-708 00 Ostrava-Pustkovec
 Phone: +420 595 691 150
 Fax: +420 595 691 199

Beijer Electronics A/S **DENMARK**
 Lykkegårdsvej 17
DK-4000 Roskilde
 Phone: +45 (0)46 / 75 76 66
 Fax: +45 (0)46 / 75 56 26

Beijer Electronics Eesti OÜ **ESTONIA**
 Pärnu mnt.160i
EE-11317 Tallinn
 Phone: +372 (0)6 / 51 81 40
 Fax: +372 (0)6 / 51 81 49

Beijer Electronics OY **FINLAND**
 Peltoie 37
FIN-28400 Ulvila
 Phone: +358 (0)207 / 463 540
 Fax: +358 (0)207 / 463 541

UTEKO **GREECE**
 5, Mavrogenous Str.
GR-18542 Piraeus
 Phone: +30 211 / 1206 900
 Fax: +30 211 / 1206 999

MELTRADE Kft. **HUNGARY**
 Fertő utca 14.
HU-1107 Budapest
 Phone: +36 (0)1 / 431-9726
 Fax: +36 (0)1 / 431-9727

Beijer Electronics SIA **LATVIA**
 Rītausmas iela 23
LV-1058 Rīga
 Phone: +371 (0)784 / 2280
 Fax: +371 (0)784 / 2281

Beijer Electronics UAB **LITHUANIA**
 Savanorių Pr. 187
LT-02300 Vilnius
 Phone: +370 (0)5 / 232 3101
 Fax: +370 (0)5 / 232 2980

EUROPEAN REPRESENTATIVES

ALFATRADE Ltd. **MALTA**
 99, Paola Hill
Malta- Paola PLA 1702
 Phone: +356 (0)21 / 697 816
 Fax: +356 (0)21 / 697 817

INTEHSIS srl **MOLDOVA**
 bld. Traian 23/1
MD-2060 Kishinev
 Phone: +373 (0)22 / 66 4242
 Fax: +373 (0)22 / 66 4280

HIFLEX AUTOM.TECHNIEK B.V. **NETHERLANDS**
 Wolweverstraat 22
NL-2984 CD Ridderkerk
 Phone: +31 (0)180 - 46 60 04
 Fax: +31 (0)180 - 44 23 55

Koning & Hartman b.v. **NETHERLANDS**
 Haarlerbergweg 21-23
NL-1101 CH Amsterdam
 Phone: +31 (0)20 / 587 76 00
 Fax: +31 (0)20 / 587 76 05

Beijer Electronics AS **NORWAY**
 Postboks 487
NO-3002 Drammen
 Phone: +47 (0)32 / 24 30 00
 Fax: +47 (0)32 / 84 85 77

Fonseca S.A. **PORTUGAL**
 R. João Francisco do Casal 87/89
PT - 3801-997 Aveiro, Esgueira
 Phone: +351 (0)234 / 303 900
 Fax: +351 (0)234 / 303 910

Sirius Trading & Services srl **ROMANIA**
 Aleea Lacul Morii Nr. 3
RO-060841 Bucuresti, Sector 6
 Phone: +40 (0)21 / 430 40 06
 Fax: +40 (0)21 / 430 40 02

Craft Con. & Engineering d.o.o. **SERBIA**
 Bulevar Svetog Cara Konstantina 80-86
SER-18106 Nis
 Phone: +381 (0)18 / 292-24-4/5
 Fax: +381 (0)18 / 292-24-4/5

INEA SR d.o.o. **SERBIA**
 Izletnicka 10
SER-113000 Smederevo
 Phone: +381 (0)26 / 617 163
 Fax: +381 (0)26 / 617 163

SIMAP s.r.o. **SLOVAKIA**
 Jána Derku 1671
SK-911 01 Trenčín
 Phone: +421 (0)32 743 04 72
 Fax: +421 (0)32 743 75 20

PROCONT, spol. s r.o. Prešov **SLOVAKIA**
 Kúpeľná 1/A
SK-080 01 Prešov
 Phone: +421 (0)51 7580 611
 Fax: +421 (0)51 7580 650

INEA d.o.o. **SLOVENIA**
 Stegne 11
SI-1000 Ljubljana
 Phone: +386 (0)1 / 513 8100
 Fax: +386 (0)1 / 513 8170

Beijer Electronics AB **SWEDEN**
 Box 426
SE-20124 Malmö
 Phone: +46 (0)40 / 35 86 00
 Fax: +46 (0)40 / 93 23 01

Omni Ray AG **SWITZERLAND**
 Im Schörl 5
CH-8600 Dübendorf
 Phone: +41 (0)44 / 802 28 80
 Fax: +41 (0)44 / 802 28 28

GTS **TURKEY**
 Bayraktar Bulvarı Nutuk Sok. No:5
TR-34775 Yukarı Dudullu-Ümraniye-İSTANBUL
 Phone: +90 (0)216 526 39 90
 Fax: +90 (0)216 526 39 95

CSC Automation Ltd. **UKRAINE**
 4-B, M. Raskovoyi St.
UA-02660 Kiev
 Phone: +380 (0)44 / 494 33 55
 Fax: +380 (0)44 / 494-33-66

EURASIAN REPRESENTATIVES

Kazpromautomatiks Ltd. **KAZAKHSTAN**
 Mustafina Str. 7/2
KAZ-470046 Karaganda
 Phone: +7 7212 / 50 11 50
 Fax: +7 7212 / 50 11 50

MIDDLE EAST REPRESENTATIVES

ILAN & GAVISH Ltd. **ISRAEL**
 24 Shenkar St., Kiryat Arie
IL-49001 Petah-Tiqva
 Phone: +972 (0)3 / 922 18 24
 Fax: +972 (0)3 / 924 0761

TEXEL ELECTRONICS Ltd. **ISRAEL**
 2 Ha'umanut, P.O.B. 6272
IL-42160 Netanya
 Phone: +972 (0)9 / 863 39 80
 Fax: +972 (0)9 / 885 24 30

CEG INTERNATIONAL **LEBANON**
 Cebaco Center/Block A Autostrade DORA
Lebanon - Beirut
 Phone: +961 (0)1 / 240 430
 Fax: +961 (0)1 / 240 438

AFRICAN REPRESENTATIVE

CBI Ltd. **SOUTH AFRICA**
 Private Bag 2016
ZA-1600 Isando
 Phone: +27 (0)11 / 977 0770
 Fax: +27 (0)11 / 977 0761