

# FX<sub>2N</sub>

This manual contains text, diagrams and explanations which will guide the reader in the correct installation and operation of the FX<sub>2N</sub>-20PSU DC power supply unit. It should be read and understood before attempting to install or use the unit. Further information can be found in the FX series PLC hardware manuals.

If in doubt at any stage during the installation of the FX<sub>2N</sub>-20PSU DC power supply unit always consult a professional electrical engineer who is qualified and trained to the local and national standards.

## Note's on the symbology used in this manual

At various times through out this manual certain symbols will be used to highlight points of information which are intended to ensure the users personal safety and protect the integrity of the equipment. Whenever any of the following symbols are encountered, its associated note must be read and understood. Each of the symbols used will now be listed with a brief description of its meaning.

### Hardware warnings



1) Indicates that the identified danger WILL cause physical and property damage.



2) Indicates that the identified danger could POSSIBLY cause physical and property damage.

### Guidelines for the safety of the user and protection of the FX<sub>2N</sub>-20PSU DC POWER SUPPLY UNIT

- This manual has been written to be used by trained and competent personnel. This is defined by the European directives for machinery, low voltage and EMC.
- If in doubt at any stage during the installation of the FX<sub>2N</sub>-20PSU always consult a professional electrical engineer who is qualified and trained to the local and national standards. If in doubt about the operation or use of the FX<sub>2N</sub>-20PSU please consult the nearest Mitsubishi Electric distributor.
- Under no circumstances will Mitsubishi Electric be liable or responsible for any consequential damage that may arise as a result of the installation or use of this equipment.
- All examples and diagrams shown in this manual are intended only as an aid to understanding the text, not to guarantee operation. Mitsubishi Electric will accept no responsibility for actual use of the product based on these illustrative examples.
- Owing to the very great variety in possible application of this equipment, you must satisfy yourself as to its suitability for your specific application.

---

---

## 1. INTRODUCTION

---

---

The DC power supply unit FX<sub>2N</sub>-20PSU is available as the following applications.

- Power supply of 24V DC power type PLC
- Power supply of special extension block of PLC
- Power supply of sensor connected to input of PLC
- Power supply of DC load connected to output of PLC
- Power supply of display unit such as graphic operation terminal (GOT)

## 2. EXTERNAL DIMENSION

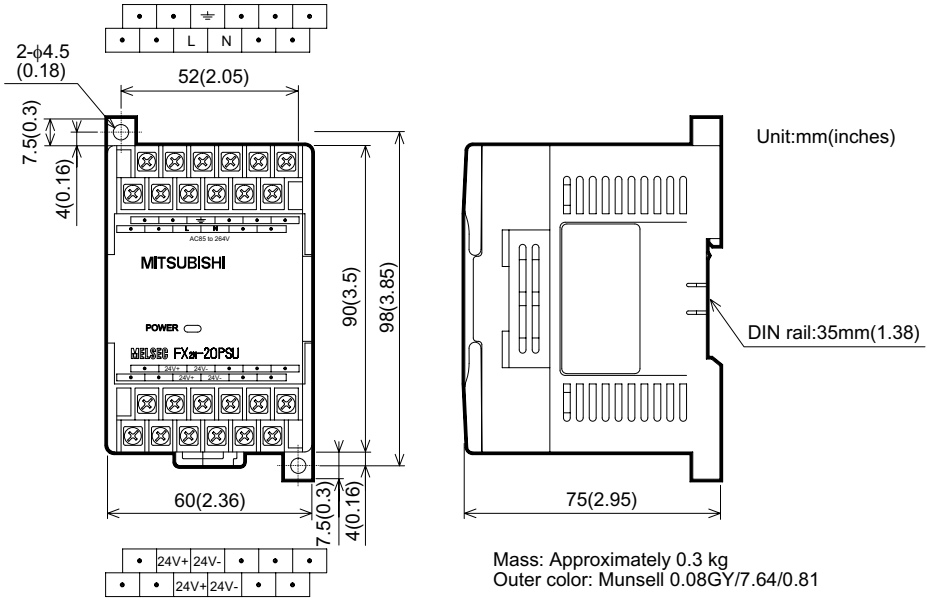

## 3. GENERAL SPECIFICATIONS

Item	Description
Operating Temperature	0 to 55 °C (32 to 131 °F)
Storage Temperature	-20 to 70 °C (-4 to 158 °F)
Operating Humidity	35 to 85% Relative Humidity, No condensation
storage Humidity	35 to 90% Relative Humidity, No condensation
Vibration Resistance - Direct Mounting	10 - 57 Hz: 0.75 mm Half Amplitude 57 - 150 Hz: 9.8 m/s <sup>2</sup> Acceleration Sweep Count for X, Y, Z: 10 times (80 min in each direction)
Vibration Resistance - DIN rail Mounting	10 - 57 Hz: 0.035 mm Half Amplitude 57 - 150 Hz: 4.9 m/s <sup>2</sup> Acceleration Sweep Count for X, Y, Z: 10 times (80 min in each direction)
Shock Resistance	147m/s <sup>2</sup> Acceleration, Action Time: 11 ms 3 times in each direction X, Y, and Z
Noise Immunity	1000Vp-p, 1microsecond, 30 - 100 Hz, tested by noise simulator
Dielectric Withstand Voltage	500V AC > 1 min, tested between all points, terminals and ground
Insulation Resistance	5MΩ > at 500V DC, tested between all points, terminals and ground
Ground	Class 3 (100 Ω or less)

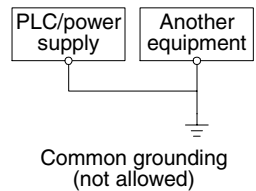
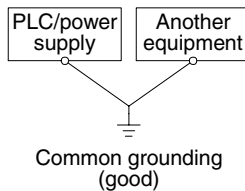
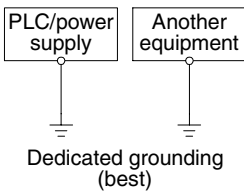

## 4. PERFORMANCE SPECIFICATIONS

Input	Input voltage	85 to 264V AC
	Frequency	50/60Hz
	Fuse rating	3.15A (built in)
	Rush current	60A/200V AC maximum
Output	Output voltage	24V DC $\pm$ 10%
	Output current	2A (maximum), 0.2A (minimum) (Derating is performed if ambient temperature exceeds 40 °C.)*1
	Ripple noise	500mVp-p or less
	Holding time	10ms/100V AC
Protection function	Protection against overcurrent *2	Actuated when current becomes 110 - 160% or more, voltage drop occurs automatic recovery
	Protection against overvoltage *3	Actuated when voltage becomes 110 - 140% or more, output shuts-down, no automatic recovery (diode clamp)
Output indication		Green LED(POWER) is lit while voltage is output.
Others		Serial/parallel operation with other power supply units is not allowed. (See Section 6.3)

[Output derating]

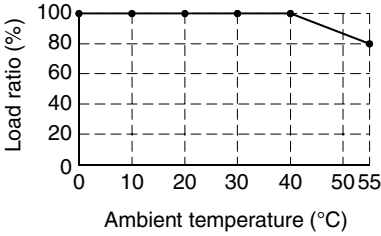

\*1 The available output current varies depending on the ambient operating temperature. Use the FX<sub>2N</sub>-20PSU in the available range in accordance with the output derating graph shown above.

\*2 If the output current flows beyond the specified value, the overcurrent protection circuit is actuated and the output voltage drops. When the overcurrent status or the short-circuit status returns to acceptable levels, the output voltage automatically recovers.

\*3 If the voltage beyond the specified value is generated by an internal failure, etc., the output is shut down so that high voltage is not output. When the voltage comes from a load circuit connected to an output terminal or when overvoltage is input from the outside, the overvoltage protection circuit may be actuated.

When the overvoltage protection circuit is actuated, the output is shut down and does not automatically recover. Ask for inspection and repair after such an occurrence.

---

---

## 5. INSTALLATION

---

---



### Cautions on installation

- Use the unit in the environment for the general specifications described in Section 3 in the manual.  
Never use the unit in a place with dust, soot, conductive dusts, corrosive gas or flammable gas, place exposed to high temperature, dew condensation, rain and wind, or in a place exposed to vibration or impact.  
If the unit is used in such a place, electrical shock, fire, malfunction, damages in the unit or deterioration of the unit may be caused.
- Never drop cutting chips or electric wire chips into the ventilation window while drilling screw holes or wiring cables.  
Such chips may cause fire, failure or malfunction.
- After finishing installation, remove a dust preventing sheet adhered on the ventilation window.  
If the sheet remains attached, fire, failure or malfunction may be caused.

### Note

- ☆ During the installation/wiring work, place a dust preventing sheet on the ventilation window.
- ☆ In order to prevent temperature rise, never install the unit on the floor surface, on the ceiling surface or in the vertical direction.  
Make sure to install the unit on a panel face in the horizontal direction as shown in the figure below.
- ☆ Use crimp-style terminals of the dimensions shown in the figure below.
- ☆ Tighten terminals at a torque of 0.5 to 0.8 N·m. Securely tighten terminals so that malfunction does not occur.

[Installation direction]

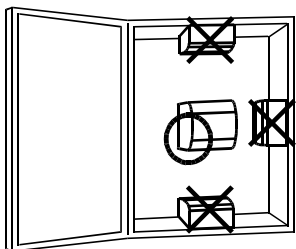

[Crimp-style terminal]

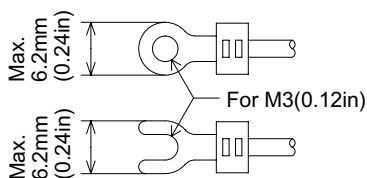

---

---

## 6. WIRING

---

---



### Cautions on wiring

- Make sure to shut down the power supplies of all phases on the outside before starting installation or wiring.  
If the power supplies are not shut down, you may get electrical shock or the unit may be damaged.
- Make sure to attach terminal covers offered as accessories before supplying power and starting operation after the installation/wiring work.
- Correctly supply power to the PLC in accordance with "Cautions on Safety" described in the manual of the PLC.  
If power is not correctly supplied, the unit may be damaged.
- Connect the wiring of the DC power supply to dedicated terminals as described in this manual.  
If the AC power supply is connected to a DC power terminal, the unit may be burnt.
- Never perform external wiring to unused terminals . Such wiring may damage the unit.
- Perform Class 3 grounding to the grounding terminal in the unit. However, never perform common grounding (See Section 3) with a strong power system.

## 6.1 When FX<sub>2N</sub>-20PSU is connected to 24V DC power type PLC

### Source inputs (-ve S/S)

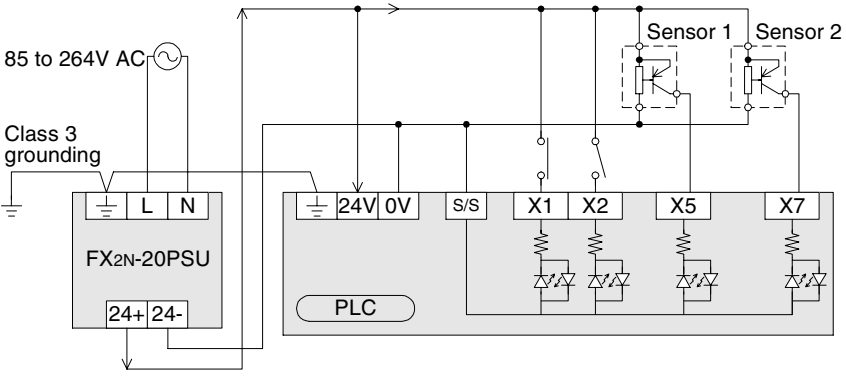

### Sink inputs (+ve S/S)

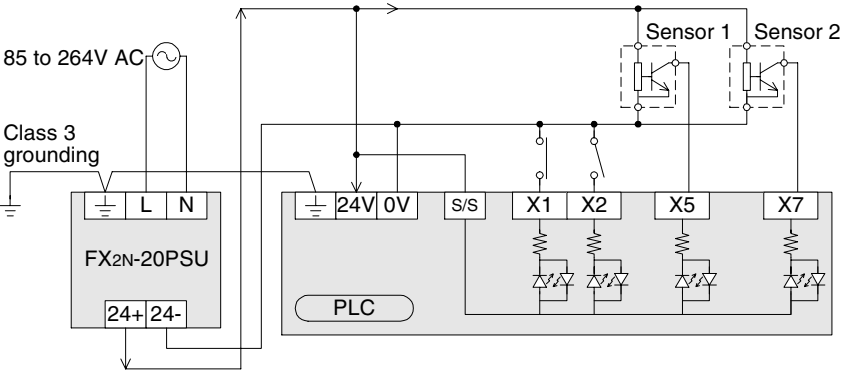

## 6.2 When FX<sub>2N</sub>-20PSU is used together with 24V DC service power supply built in PLC

In the AC power type FX PLC, a 24V DC service power supply is built.

When using the FX<sub>2N</sub>-20PSU and the service power supply together, connect the "24-" terminal of the FX<sub>2N</sub>-20PSU and the "COM" terminal on the minus side of the service power supply as shown in the figure below.

### Source inputs (-ve S/S)

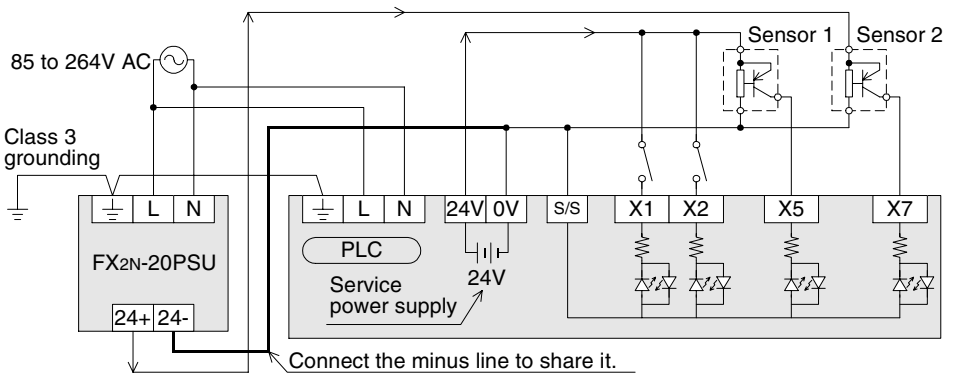

### Sink inputs (+ve S/S)

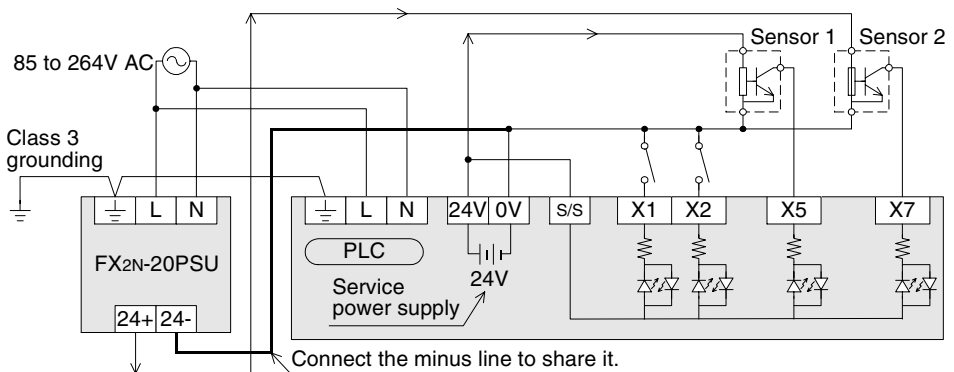

## 6.3 Cautions



### Cautions on design

- Never connect in serial nor parallel the DC output terminals of the FX<sub>2N</sub>-20PSU to another power supply unit.  
Such a connection may damage the unit.
- ☆ Never connect the FX<sub>2N</sub>-20PSU in parallel to another power supply unit.

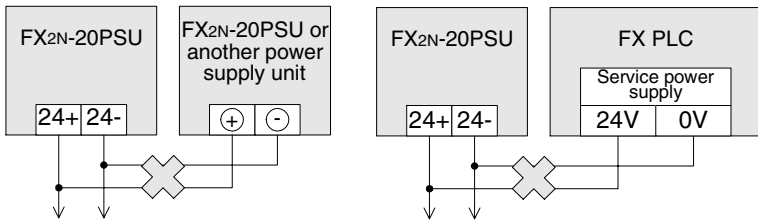

- ☆ Never connect the FX<sub>2N</sub>-20PSU serially to another power supply unit.

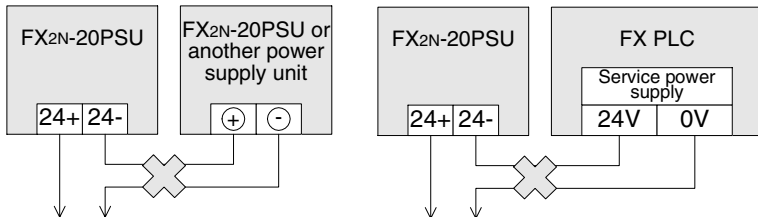

---

---

## 7. TROUBLESHOOTING

---

---

When it is suspected that the FX<sub>2N</sub>-20PSU is not normally operating, check the following items.

- Check the POWER LED status.

[When the POWER LED is extinguished]

- Check the input voltage of the FX<sub>2N</sub>-20PSU.

If any abnormality is detected → Input the specified supply voltage.

- Disconnect the wiring from the output terminals "24+" and "24-".

If the POWER LED lights → The overcurrent protection circuit (See Section 4) is actuated. Investigate the load connected to the output terminals.

If the POWER LED remains extinguished → The overvoltage protection circuit (See Section 4) may be actuated. Ask for inspection and repair.

[When the POWER LED is lit]

- Check the input voltage of the FX<sub>2N</sub>-20PSU.

If any abnormality is detected → Input the specified supply voltage.

- Check the external wiring.

If any abnormality is detected → Correct the wiring (See Section 6).

- The overcurrent protection circuit and the overvoltage protection circuit are built in the FX<sub>2N</sub>-20PSU. If such a protection circuit is actuated, the output voltage drops or is shut down. For details, refer to Section 4.

Manual number : JY992D85101

Manual revision : B

Date : SEP. 2008



HEAD OFFICE : TOKYO BUILDING, 2-7-3 MARUNOUCHI, CHIYODA-KU, TOKYO 100-8310, JAPAN  
HIMEJI WORKS : 840, CHIYODA CHO, HIMEJI, JAPAN

# FX<sub>2N</sub>

FX<sub>2N</sub>-20PSU DC POWER SUPPLY UNIT

## USER'S MANUAL

JY992D85101B



This manual contains text, diagrams and explanations which will guide the reader in the correct installation and operation of the FX<sub>2N</sub>-20PSU DC power supply unit. It should be read and understood before attempting to install or use the unit. Further information can be found in the FX series PLC hardware manuals.

If in doubt at any stage during the installation of the FX<sub>2N</sub>-20PSU DC power supply unit always consult a professional electrical engineer who is qualified and trained to the local and national standards.

### Note's on the symbology used in this manual

At various times through out this manual certain symbols will be used to highlight points of information which are intended to ensure the users personal safety and protect the integrity of the equipment. Whenever any of the following symbols are encountered, its associated note must be read and understood. Each of the symbols used will now be listed with a brief description of its meaning.

### Hardware warnings

-  1) Indicates that the identified danger WILL cause physical and property damage.
-  2) Indicates that the identified danger could POSSIBLY cause physical and property damage.

### Guidelines for the safety of the user and protection of the FX<sub>2N</sub>-20PSU DC POWER SUPPLY UNIT

- This manual has been written to be used by trained and competent personnel. This is defined by the European directives for machinery, low voltage and EMC.
- If in doubt at any stage during the installation of the FX<sub>2N</sub>-20PSU always consult a professional electrical engineer who is qualified and trained to the local and national standards. If in doubt about the operation or use of the FX<sub>2N</sub>-20PSU please consult the nearest Mitsubishi Electric distributor.
- Under no circumstances will Mitsubishi Electric be liable or responsible for any consequential damage that may arise as a result of the installation or use of this equipment.
- All examples and diagrams shown in this manual are intended only as an aid to understanding the text, not to guarantee operation. Mitsubishi Electric will accept no responsibility for actual use of the product based on these illustrative examples.
- Owing to the very great variety in possible application of this equipment, you must satisfy yourself as to its suitability for your specific application.

## 1. INTRODUCTION

The DC power supply unit FX<sub>2N</sub>-20PSU is available as the following applications.

- Power supply of 24V DC power type PLC
- Power supply of special extension block of PLC
- Power supply of sensor connected to input of PLC
- Power supply of DC load connected to output of PLC
- Power supply of display unit such as graphic operation terminal (GOT)

## 2. EXTERNAL DIMENSION

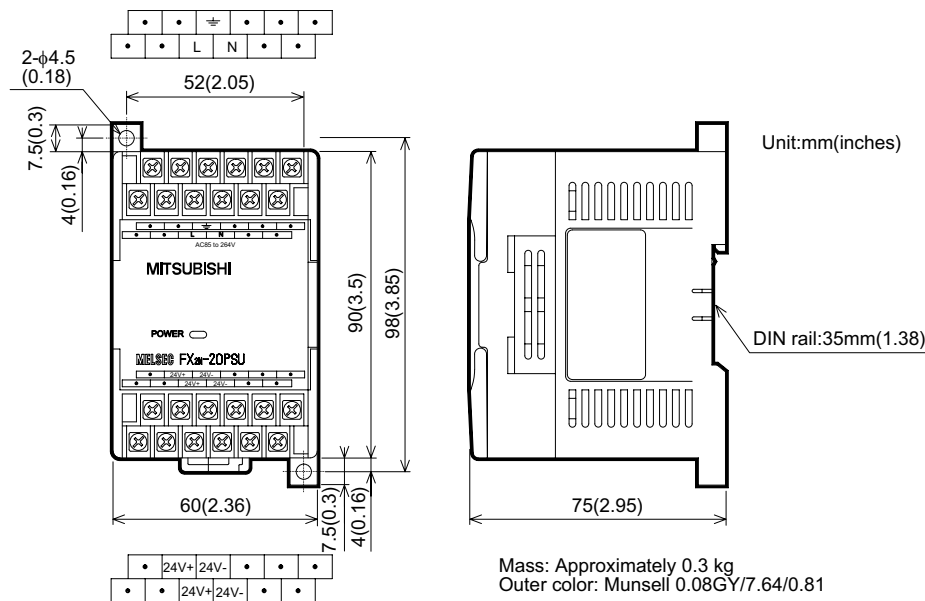

## 3. GENERAL SPECIFICATIONS

Item	Description
Operating Temperature	0 to 55 °C (32 to 131 °F)
Storage Temperature	-20 to 70 °C (-4 to 158 °F)
Operating Humidity	35 to 85% Relative Humidity, No condensation
storage Humidity	35 to 90% Relative Humidity, No condensation
Vibration Resistance - Direct Mounting	10 - 57 Hz: 0.75 mm Half Amplitude 57 - 150 Hz: 9.8 m/s <sup>2</sup> Acceleration Sweep Count for X, Y, Z: 10 times (80 min in each direction)
Vibration Resistance - DIN rail Mounting	10 - 57 Hz: 0.035 mm Half Amplitude 57 - 150 Hz: 4.9 m/s <sup>2</sup> Acceleration Sweep Count for X, Y, Z: 10 times (80 min in each direction)
Shock Resistance	147m/s <sup>2</sup> Acceleration, Action Time: 11 ms 3 times in each direction X, Y, and Z
Noise Immunity	1000Vp-p, 1microsecond, 30 - 100 Hz, tested by noise simulator
Dielectric Withstand Voltage	500V AC > 1 min, tested between all points, terminals and ground
Insulation Resistance	5MΩ > at 500V DC, tested between all points, terminals and ground
Ground	Class 3 (100 Ω or less)

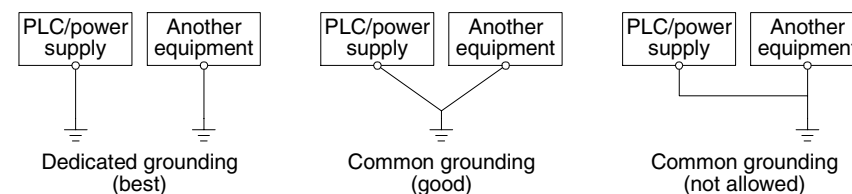

## 4. PERFORMANCE SPECIFICATIONS

Input	Input voltage	85 to 264V AC
	Frequency	50/60Hz
	Fuse rating	3.15A (built in)
	Rush current	60A/200V AC maximum
Output	Output voltage	24V DC ± 10%
	Output current	2A (maximum), 0.2A (minimum) (Derating is performed if ambient temperature exceeds 40 °C.) <sup>*1</sup>
	Ripple noise	500mVp-p or less
	Holding time	10ms/100V AC
Protection function	Protection against overcurrent <sup>*2</sup>	Actuated when current becomes 110 - 160% or more, voltage drop occurs automatic recovery
	Protection against overvoltage <sup>*3</sup>	Actuated when voltage becomes 110 - 140% or more, output shuts-down, no automatic recovery (diode clamp)
Output indication	Green LED(POWER) is lit while voltage is output.	
Others	Serial/parallel operation with other power supply units is not allowed. (See Section 6.3)	

[Output derating]

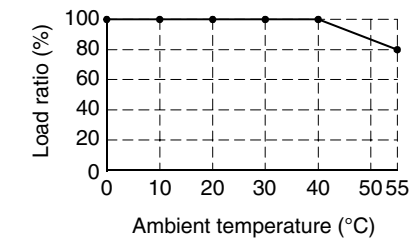

<sup>\*1</sup> The available output current varies depending on the ambient operating temperature. Use the FX<sub>2N</sub>-20PSU in the available range in accordance with the output derating graph shown above.

<sup>\*2</sup> If the output current flows beyond the specified value, the overcurrent protection circuit is actuated and the output voltage drops. When the overcurrent status or the short-circuit status returns to acceptable levels, the output voltage automatically recovers.

<sup>\*3</sup> If the voltage beyond the specified value is generated by an internal failure, etc., the output is shut down so that high voltage is not output. When the voltage comes from a load circuit connected to an output terminal or when overvoltage is input from the outside, the overvoltage protection circuit may be actuated. When the overvoltage protection circuit is actuated, the output is shut down and does not automatically recover. Ask for inspection and repair after such an occurrence.

## 5. INSTALLATION



### Cautions on installation

- Use the unit in the environment for the general specifications described in Section 3 in the manual.  
Never use the unit in a place with dust, soot, conductive dusts, corrosive gas or flammable gas, place exposed to high temperature, dew condensation, rain and wind, or in a place exposed to vibration or impact.  
If the unit is used in such a place, electrical shock, fire, malfunction, damages in the unit or deterioration of the unit may be caused.
- Never drop cutting chips or electric wire chips into the ventilation window while drilling screw holes or wiring cables.  
Such chips may cause fire, failure or malfunction.
- After finishing installation, remove a dust preventing sheet adhered on the ventilation window.  
If the sheet remains attached, fire, failure or malfunction may be caused.

### Note

- During the installation/wiring work, place a dust preventing sheet on the ventilation window.
- In order to prevent temperature rise, never install the unit on the floor surface, on the ceiling surface or in the vertical direction.  
Make sure to install the unit on a panel face in the horizontal direction as shown in the figure below.
- Use crimp-style terminals of the dimensions shown in the figure below.
- Tighten terminals at a torque of 0.5 to 0.8 N·m. Securely tighten terminals so that malfunction does not occur.

[Installation direction]

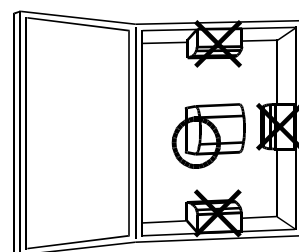

[Crimp-style terminal]

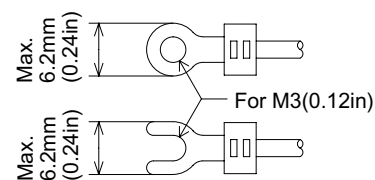

## 6. WIRING



### Cautions on wiring

- Make sure to shut down the power supplies of all phases on the outside before starting installation or wiring.  
If the power supplies are not shut down, you may get electrical shock or the unit may be damaged.
- Make sure to attach terminal covers offered as accessories before supplying power and starting operation after the installation/wiring work.
- Correctly supply power to the PLC in accordance with "Cautions on Safety" described in the manual of the PLC.  
If power is not correctly supplied, the unit may be damaged.
- Connect the wiring of the DC power supply to dedicated terminals as described in this manual.  
If the AC power supply is connected to a DC power terminal, the unit may be burnt.
- Never perform external wiring to unused terminals . Such wiring may damage the unit.
- Perform Class 3 grounding to the grounding terminal in the unit. However, never perform common grounding (See Section 3) with a strong power system.

### 6.1 When FX<sub>2N</sub>-20PSU is connected to 24V DC power type PLC

#### Source inputs (-ve S/S)

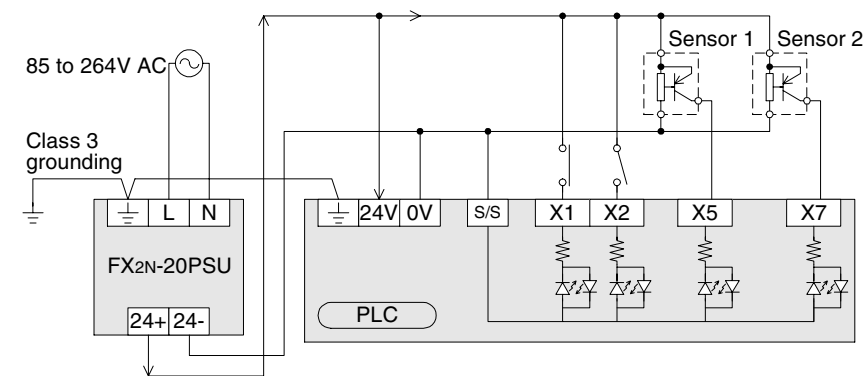

#### Sink inputs (+ve S/S)

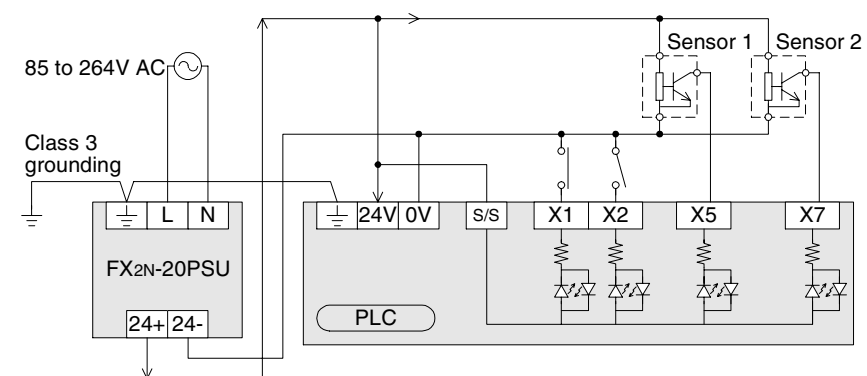

### 6.2 When FX<sub>2N</sub>-20PSU is used together with 24V DC service power supply built in PLC

In the AC power type FX PLC, a 24V DC service power supply is built.  
When using the FX<sub>2N</sub>-20PSU and the service power supply together, connect the "24-" terminal of the FX<sub>2N</sub>-20PSU and the "COM" terminal on the minus side of the service power supply as shown in the figure below.

#### Source inputs (-ve S/S)

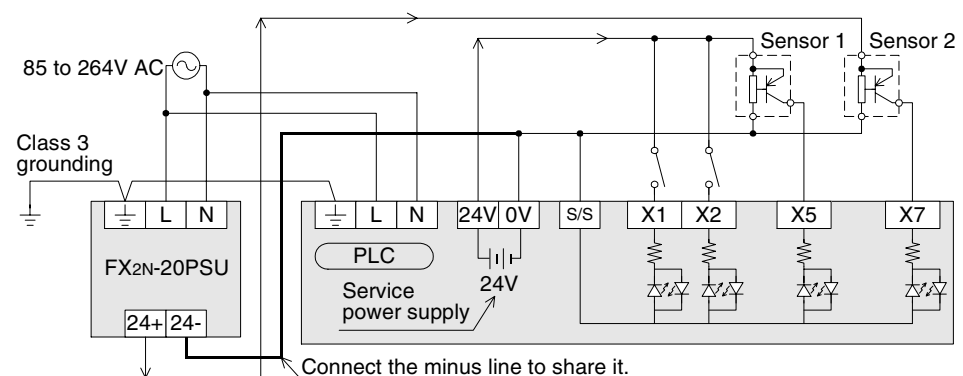

#### Sink inputs (+ve S/S)

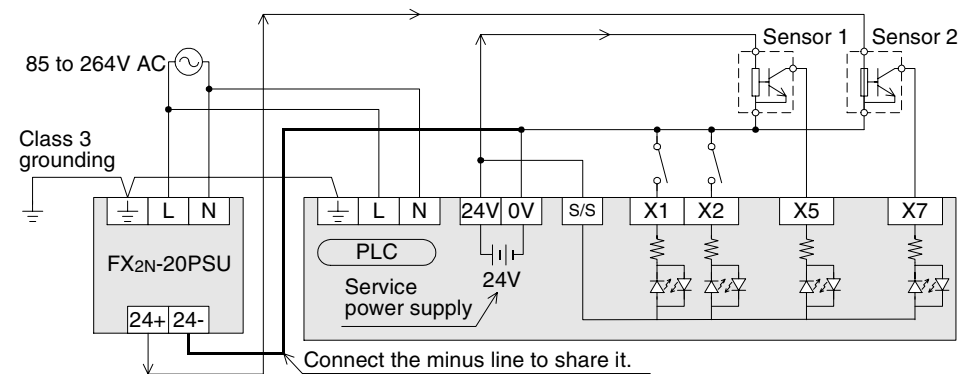

## 6.3 Cautions



### Cautions on design

- Never connect in serial nor parallel the DC output terminals of the FX<sub>2N</sub>-20PSU to another power supply unit.  
Such a connection may damage the unit.
- Never connect the FX<sub>2N</sub>-20PSU in parallel to another power supply unit.
- Never connect the FX<sub>2N</sub>-20PSU serially to another power supply unit.

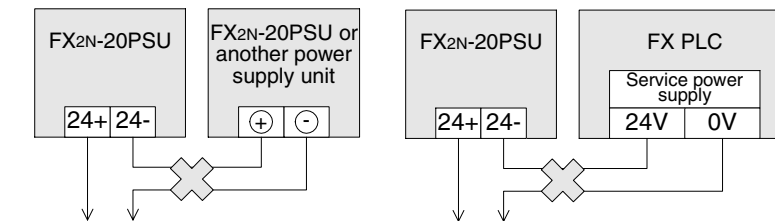
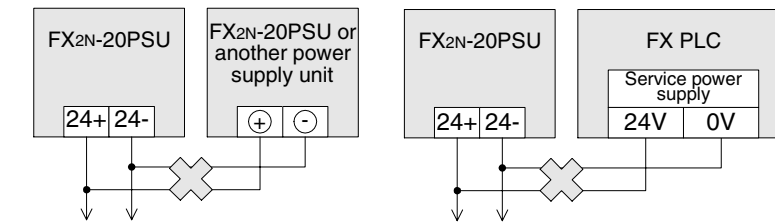

## 7. TROUBLESHOOTING

When it is suspected that the FX<sub>2N</sub>-20PSU is not normally operating, check the following items.

- Check the POWER LED status.
  - [When the POWER LED is extinguished]
    - Check the input voltage of the FX<sub>2N</sub>-20PSU.  
If any abnormality is detected → Input the specified supply voltage.
    - Disconnect the wiring from the output terminals "24+" and "24-".  
If the POWER LED lights → The overcurrent protection circuit (See Section 4) is actuated. Investigate the load connected to the output terminals.
    - If the POWER LED remains extinguished → The overvoltage protection circuit (See Section 4) may be actuated. Ask for inspection and repair.
  - [When the POWER LED is lit]
    - Check the input voltage of the FX<sub>2N</sub>-20PSU.  
If any abnormality is detected → Input the specified supply voltage.
    - Check the external wiring.  
If any abnormality is detected → Correct the wiring (See Section 6).
- The overcurrent protection circuit and the overvoltage protection circuit are built in the FX<sub>2N</sub>-20PSU. If such a protection circuit is actuated, the output voltage drops or is shut down. For details, refer to Section 4.

Manual number : JY992D85101

Manual revision : B

Date : SEP. 2008

**MITSUBISHI ELECTRIC CORPORATION**

HEAD OFFICE : TOKYO BUILDING, 2-7-3 MARUNOUCHI, CHIYODA-KU, TOKYO 100-8310, JAPAN  
HIMEJI WORKS : 840, CHIYODA CHO, HIMEJI, JAPAN