

# **MELSEC Q Series**

Programmable Logic Controller

User's Manual  
(Hardware)

**QJ71C24N(-R2/-R4)**

**QJ71C24(-R2)**

**Serial Communication Module**

## • SAFETY PRECAUTIONS •

(Be sure to read these instructions before using the product.)

Before using this product, read this manual and the relevant manuals introduced in this manual carefully and handle the product correctly with full attention to safety.

Note that these precautions apply only to this product. Refer to the user's manual of the CPU module for the PLC system safety precautions. In this manual, the safety instructions are ranked as "DANGER" and "CAUTION".



Indicates that incorrect handling may cause hazardous conditions, resulting in death or severe injury.



Indicates that incorrect handling may cause hazardous conditions, resulting in minor or moderate injury or property damage.

Note that failure to observe the  **CAUTION** level instructions may also lead to serious results depending on the circumstances.

Be sure to observe the instructions of both levels to ensure personal safety.

Please keep this manual in accessible place and be sure to forward it to the end user.

## [DESIGN PRECAUTIONS]

### CAUTION

- Do not bundle the control lines or communication cables with the main circuit or power lines, or bring them close to each other.  
The distance of 100mm(3.9inch) or more should be ensured.  
Failure to do so cause malfunctions due to noise.

## [INSTALLATION PRECAUTIONS]

### CAUTION

- Use the PLC in the environment specified in the user's manual of the CPU module.  
Failure to do so may cause electric shock, fires, malfunctions, product deterioration or damage.
- When mounting the module, fully insert the module fixing projection into the corresponding fixing hole on the base unit while pressing the module fixing lever at the bottom of the module.  
Incorrect mounting may cause malfunctions, failures or a fall of the module.  
The module should be secured with screws in an environment of frequent vibration.
- Tighten the screws within the specified torque range.  
Loose tightening may cause a fall, short circuits, or malfunctions.  
Overtightening may damage the screws and/or the module, resulting in a fall of the module, short circuits or malfunctions.
- Be sure to shut off all phases of the external power supply before mounting or removing the module.  
Failure to do so may damage the module.
- Do not directly touch the conductive part or electronic components of the module.  
This may cause malfunctions or a failure of the module.

## [WIRING PRECAUTIONS]

### CAUTION

- When energizing and operating the product after mounting and wiring, be sure to cover the terminals with the provided terminal covers.  
Failure to do so may result in malfunctions.
- When wiring the external connection connectors, correctly press, pressure-weld or solder the connecting part by using the tool specified by the manufacturer.  
Poor connection may cause short circuits, fires or malfunctions.
- Connect the connectors to the module securely.
- Be sure to fix communication cables and power cables to the module by ducts or clamps.  
Failure to do so may cause damage of the module or the cables due to accidental pull or unintentional shifting of the cables, or malfunctions due to poor contact of the cable.
- When connecting a cable, check the interface type and connect it correctly.  
Connecting to a wrong interface or faulty wiring may cause failure of the module and/or external devices.
- Tighten the terminal screws within the specified torque range.  
Loose tightening may result in a fall, short circuits or malfunctions.  
Overtightening may cause damage to the screw and/or the module, resulting in a fall, short circuits or malfunctions.
- Do not hold the communication cable by hand when pulling it out from the module.  
Be sure to hold the connector by hand, when removing the cable with a connector from the module.  
Failure to do so may cause malfunctions or damage to the module or cable.
- Be careful not to let foreign matter such as dust or wire chips get inside the module. This may cause a fire, failure or malfunctions.
- A protection label is attached to cover the upper part of a module to prevent the entry of foreign matter. Do not remove the label during wiring.  
However, be sure to remove it for heat dissipation during system operation.

## Revisions

\* The manual number is given on the bottom left of the back cover.

Print Date	*Manual Number	Revision
Sep., 1999	IB(NA)-0800008-A	First printing
Dec., 1999	IB(NA)-0800008-B	<div style="border: 1px solid black; padding: 2px;">Addition</div> <p>"Compliance with the EMC Directive and Low Voltage Directive", Chapter 6 (1) (a) *· (c) *·(2) REMARK</p> <div style="border: 1px solid black; padding: 2px;">Correction</div> <p>"Safety Precautions", Chapter 2, Section 5.2 (3)</p>
Sep., 2000	IB(NA)-0800008-C	<p>Add the contents of the function version B. Put Windows<sup>®</sup> base software products together from Mitsubishi Programmable Logic Controller MELSEC series to Mitsubishi integrated FA software MELSOFT series. Standardize the name from software package (GPP function) to product name (GX Developer).</p> <div style="border: 1px solid black; padding: 2px;">Correction</div> <p>"Safety Precautions", "Manuals", "Compliance with the EMC Directive and Low Voltage Directive", Chapter 2, Chapter 6(1)(b)(c).</p>
Dec., 2002	IB(NA)-0800008-D	<div style="border: 1px solid black; padding: 2px;">Addition model</div> <p>QJ71C24N, QJ71C24N-R2, QJ71C24N-R4</p>
Feb., 2003	IB(NA)-0800008-E	<div style="border: 1px solid black; padding: 2px;">Addition</div> <p>Chapter 1, Section 3.1</p>

This manual confers no industrial property rights or any rights of any other kind, nor does it confer any patent licenses. Mitsubishi Electric Corporation cannot be held responsible for any problems involving industrial property rights which may occur as a result of using the contents noted in this manual.

© 1999 MITSUBISHI ELECTRIC CORPORATION

# CONTENTS

1. Overview .....	1
2. Performance Specifications .....	2
3. Mounting and Installation .....	3
3.1 Handling Precautions .....	3
3.2 Installation Environment .....	3
4. Part Names .....	4
5. External Wiring .....	6
5.1 Connecting to the RS-232 line .....	6
5.2 Connecting to the RS-422/485 line .....	9
6. Setting from GX Developer .....	13
7. External Dimensions .....	16

## Manuals

The following table lists manuals relevant to this product.  
If necessary, obtain a proper manual in accordance with the intended use.

### Relevant Manuals

Manual name	Manual No. (Model code)
Q Corresponding Serial Communication Module User's Manual (Basic)	SH-080006 (13JL86)
Q Corresponding Serial Communication Module User's Manual (Application)	SH-080007 (13JL87)
Q Corresponding MELSEC Communication Protocol Reference Manual	SH-080008 (13JF89)

Please read the Q Corresponding Serial Communication Module User's Manual (Basic) before using this module.

## **Compliance with the EMC Directive and the Low Voltage Directive**

When incorporating Mitsubishi PLC into other machine or equipment and making it comply with the EMC directive and the low voltage directive, refer to Chapter 3, "EMC Directive and Low Voltage Directive" of the User's Manual (Hardware) for the CPU module.

The CE logo is printed on the rating plate of the PLC, indicating compliance with the EMC directive and the low voltage directive.

No measured for compliance with the EMC Directive and the low voltage directive are required for this product.

# 1. Overview

This manual is written to provide proper information and instructions on installation and wiring of the QJ71C24N, QJ71C24N-R2, QJ71C24N-R4, QJ71C24 and QJ71C24-R2 serial communication modules (hereinafter referred to as the serial communication module).

Check that the following items are included with the product package.

Model name	Product name	Quantity
QJ71C24N or QJ71C24	QJ71C24N or QJ71C24 serial communication module	1
	Terminal resistor for RS-422 communication 330Ω 1/4 W (Orange-Orange-Brown) *1	2
	Terminal resistor for RS-485 communication 110Ω 1/2 W (Brown-Brown-Brown) *1	2
QJ71C24N-R2 or QJ71C24-R2	QJ71C24N-R2 or QJ71C24-R2 serial communication module	1
QJ71C24N-R4	QJ71C24N-R4 serial communication module	1
	RS-422/485 plug-in connector socket block	2
	Terminal resistor for RS-422 communication 330Ω 1/4 W (Orange-Orange-Brown) *1	4
	Terminal resistor for RS-485 communication 110Ω 1/2 W (Brown-Brown-Brown) *1	4
	Plate terminal for braided shield cable connection	4

\*1: Differentiate the terminal resistors as follows:

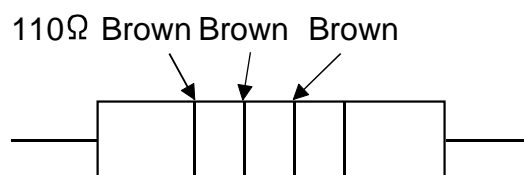
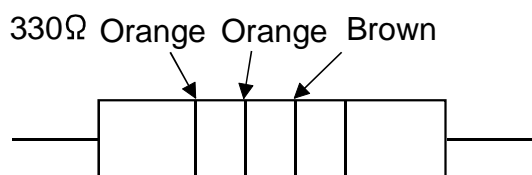

## 2. Performance Specifications

The following describes the performance specifications of the serial communication module.

Use the modem function with reference to the relevant performance specifications in the user's manual (Basic).

For general specifications of the serial communication module, refer to the user's manual of the CPU module.

Item		Specifications (when the modem function is not used)						
		QJ71C24N QJ71C24	QJ71C24N-R2 QJ71C24-R2	QJ71C24N-R4				
Interface	CH.1	RS-232-compliance (D-sub 9P)	RS-232-compliance (D-sub 9P)	RS-422/485-compliance (2-piece plug-in connector socket block)				
	CH.2	RS-422/485-compliance (2-piece terminal block)	RS-232-compliance (D-sub 9P)	RS-422/485-compliance (2-piece plug-in connector socket block)				
Synchronization method		Start-stop synchronization method						
Transmission speed		[QJ71C24N(-R2/R4)]						
		50	300	600	1200	2400	4800	9600
14400	19200	28800	38400	57600	115200	230400	(bps)	
		<ul style="list-style-type: none"> <li>• Transmission speed 230400 bps is available for only CH1. (Not available for CH2)</li> <li>• Total transmission speed of two interfaces is available up to 230400 bps.</li> <li>• Total transmission speed of two interfaces is available up to 115200 bps when the communication data monitoring function is used.</li> </ul>						
		[QJ71C24(-R2)]						
		50	300	600	1200	2400	4800	9600
14400	19200	28800	38400	57600	115200	-	(bps)	
		<ul style="list-style-type: none"> <li>• Total transmission speed of two interfaces is available up to 115200 bps.</li> </ul>						
Data format	Start bit	1						
	Data bit	7/8						
	Parity bit	1(vertical parity) or none						
	Stop bit	1/2						
Error detection	Parity check	For all protocol, select odd/even by the parameter when there is an error.						
	Sum check code	Select by the parameter for MC protocol/Bidirectional protocol. Select by the user entry frame for non-procedure protocol.						
Transmission distance (Overall distance)	RS-232	Maximum 15 m (49.2 ft.)	Maximum 15 m (49.2 ft.)					-
	RS-422/485	Maximum 1200 m (4592.4 ft.) (overall distance)	-					Maximum 1200 m (4592.4 ft.) (overall distance)
Allowable number of writes to flash ROM		Maximum 100,000 writes to the same area						
Number of occupied I/O points		32 points per slot (I/O assignment: Intelli: 32 points)						



Item		Specifications (when the modern function is not used)		
		QJ71C24N QJ71C24	QJ71C24N-R2 QJ71C24-R2	QJ71C24N-R4
Recommended cable	RS-232	7/0. 127 □P HRV-SV Outside diameter 8.5mm (0.33in.) or more (Oki Electric Cable Co., Ltd. Applicable number is specified in □.)		
	RS-422/485 (*1)	SPEV (SB)-MPC-0.2×3P Outside diameter approx. 6.5mm (0.26 in.) (Mitsubishi Cable Industries, LTD.) SPEV(SB)-0.2×3P Outside diameter approx. 7.5mm (0.3 in.) (Mitsubishi Cable Industries, LTD.)		
Applicable connector for external wiring		9 pin D-sub (male) screw type (*2)		-
5V DC internal current consumption		0.31A	0.26A	0.39A
External dimensions		98 (3.86 in.) (H) × 27.4 (1.08 in.) (W) × 90 (3.54 in.) (D)[mm]		
Weight		0.20kg (0.44lb)		

\*1: Recommended cables SPEV (SB)-MPC-0.2 × 3P and SPEV (SB)-0.2 × 3P are equivalent in the electrical characteristics, but partially different in the outside diameter, internal wire colors, etc.

\*2: Refer to Section 5.1 for the recommended cable.

## 3. Mounting and Installation

### 3.1 Handling Precautions

- (1) Since the case of the module is made of resin, do not drop or apply strong impact.
- (2) Always make sure to touch the grounded metal to discharge the electricity charged in the body, etc., before touching the module.  
Failure to do so may cause a failure or malfunctions of the module.
- (3) Tighten the terminal block and module installation screws within the specified torque range as follows:

Screw location	Tightening torque range
RS-422/485 terminal block terminal screws (M3 screw)	42 to 58N•cm
RS-422/485 plug-in connector socket block terminal screw for QJ71C24N-R4 (M2 screw)	20 to 25N•cm
Module fixing screw (normally not required) (M3 screw) (*1)	36 to 48N•cm

\*1: The module can be simply fixed onto the base unit with a hook on the module's upper part. However, for installation in an environment with high vibration and/or strong impact, it is advisable to fix it with the module fixing screws.

### 3.2 Installation Environment

For further details, refer to the user's manual for the CPU module.

## 4. Part Names

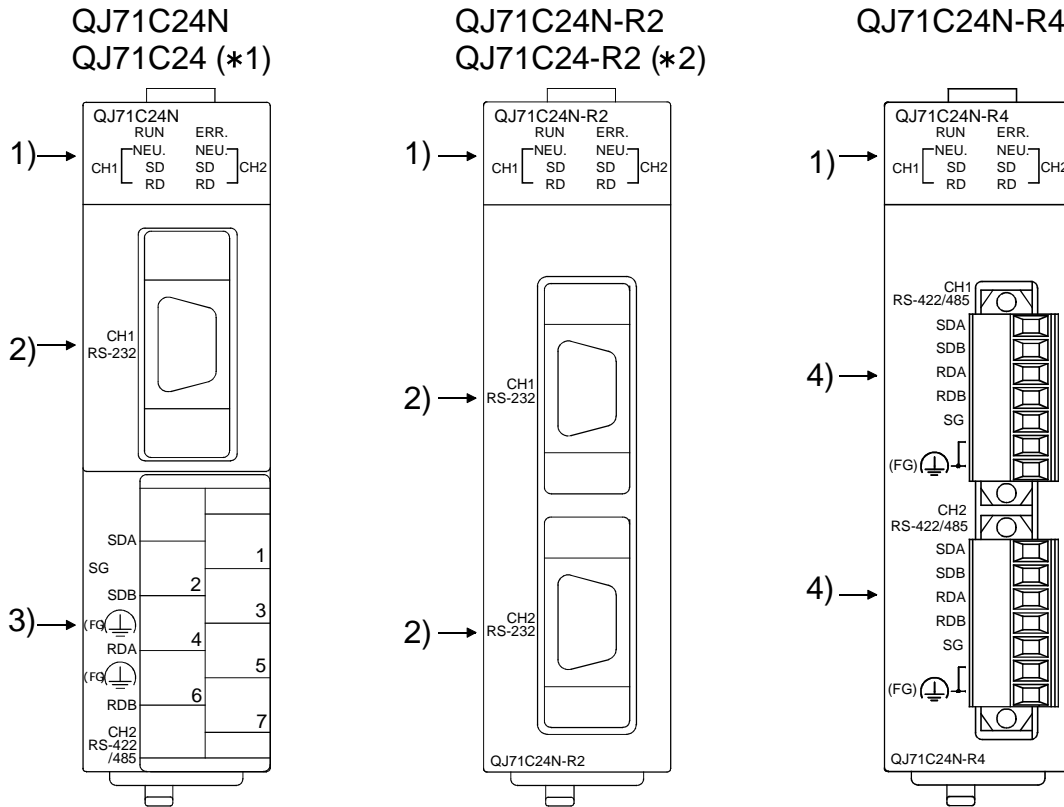

\*1: The dimensions of the QJ71C24 are the same as QJ71C24N (except for model name).

\*2: The dimensions of the QJ71C24-R2 are the same as QJ71C24N-R2 (except for model name).

	Name	Contents
1)	Display LED	Display LED (For details, see Section (1).)
2)	RS-232 Interface	RS232 interface for serial communication with external devices (D-Sub 9P)
3)	RS-422/485 Interface	RS422/485 interface for serial communication with external devices (2-piece terminal block)
4)	RS-422/485 Interface	RS422/485 interface for serial communication with external devices (2-piece plug-in socket block)

## (1) LED display list

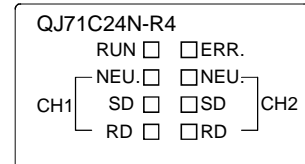
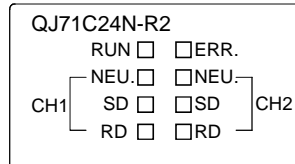
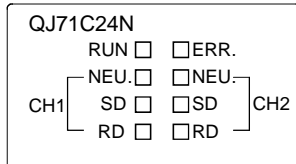

CH	LED	Display contents	ON/Flickering	OFF	Compatible protocol		
					MC	Non-procedural	Bidirectional
-	RUN	Normal operation display	Normal	Faulty or reset	Valid		
	ERR	Error display (*1)	Error has occurred	Normal			
CH1	NEU (*3)	Neutral status on the CH1 side display (*2)	Waiting for MC command message to be received	MC command message being received	Valid	Invalid (OFF)	
	SD	Transmission status display	Data being transmitted	Data not transmitted	Valid		
	RD	Reception status display	Data being received	Data not received			
CH2	NEU (*3)	Neutral status on the CH2 side display (*2)	Waiting for MC command message to be received	MC command message being received	Valid	Invalid (OFF)	
	SD	Transmission status display	Data being transmitted	MC command message not transmitted	Valid		
	RD	Reception status display	Data being received	MC command message not received			

\*1: This LED turns ON when an error occurs at serial communication module hardware or during data communication.

\*2: This LED displays the data communication status via MC protocol.  
 On: Waiting for the command message to be received from the external device.

Off: Processing the command message received from the external device.

\*3: This LED can be made valid also when "GX Developer connection" (0H) is specified in communication protocol setting.

## 5. External Wiring

### 5.1 Connecting to the RS-232 line

This section explains the standard method for connecting the RS-232 line.

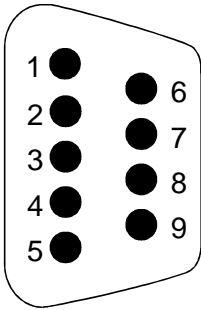

Pin number	Signal abbreviation	Signal name	Signal direction	
			C24 (*1)	External device
1	CD	Receive carrier	←	←
2	RD(RXD)	Reception data	←	←
3	SD(TXD)	Transmission	→	→
4	DTR(ER)	Data terminal ready	→	→
5	SG	Signal ground	↔	↔
6	DSR(DR)	Data set ready	←	←
7	RS(RTS)	Transmission request	→	→
8	CS(CTS)	Transmission possible	←	←
9	RI(CI)	Called status display	←	←

\*1: QJ71C24N, QJ71C24 : CH1 side,  
 QJ71C24N-R2 QJ71C24-R2 : CH1/CH2 side

The module uses the following type of RS-232 interface connector.

9-pin D-sub (female) screw fixing type

Use either of the following as a connector shell for the connection cable of the module.

- 3M  
 Plug model: 8209-6009                      Shell model: 3702-2209 M2.6
- Tyco Electronics AMP K.K.  
 Plug model: 747904-2                      Shell model: 747515 or 174469-2

#### POINT

To connect the module with a modem/TA when using modem function, install wiring as specified for the modem/TA.

(1) Example of connection to an external device which can turn on/off the CD signal (pin No. 1)

The module		Cable connection and signal direction (Connection example of full or half duplex communication)	External device
Signal name	Pin number		Signal name
CD	1		CD
RD(RXD)	2		RD(RXD)
SD(TXD)	3		SD(TXD)
DTR(ER)	4		DTR(ER)
SG	5		SG
DSR(DR)	6		DSR(DR)
RS(RTS)	7		RS(RTS)
CS(CTS)	8		CS(CTS)
RI(CI)	9		

(2) Example of connection to an external device which cannot turn on/off the CD signal (pin No. 1)

(a) Example of connection for DC code control or DTR/DSR control

The module		Cable connection and signal direction (Connection example of full duplex communication)	External device
Signal name	Pin number		Signal name
CD	1		CD
RD(RXD)	2		RD(RXD)
SD(TXD)	3		SD(TXD)
DTR(ER)	4		DTR(ER)
SG	5		SG
DSR(DR)	6		DSR(DR)
RS(RTS)	7		RS(RTS)
CS(CTS)	8		CS(CTS)
RI(CI)	9		

(b) Example of connection for DC code control

The module		Cable connection and signal direction (Connection example of full duplex communication)	External device
Signal name	Pin number		Signal name
CD	1		CD
RD(RXD)	2		RD(RXD)
SD(TXD)	3		SD(TXD)
DTR(ER)	4		DTR(ER)
SG	5		SG
DSR(DR)	6		DSR(DR)
RS(RTS)	7		RS(RTS)
CS(CTS)	8		CS(CTS)
RI(CI)	9		

(3) Connection precaution

(a) Treat the FG signal and shield of the connection cable as indicated below:

	Connection method	Remark
FG signal	Connect to the connector enclosure of the module.	<ul style="list-style-type: none"> <li>Do not short the FG signal and SG signal of the connector cable.</li> </ul>
Shield	Connect to the FG terminal of the external device or connector enclosure of the module.	<ul style="list-style-type: none"> <li>When the FG signal and SG signal are internally connected in the external device, do not connect the FG signal to the module.</li> </ul>

(b) If data communication cannot be performed normally due to external noise, install wiring as follows:

- Connect the FG terminal of the external device and the connector enclosure of the module using the connector cable shield.
- Use a twisted pair style between each signal (except SG) and SG signal.

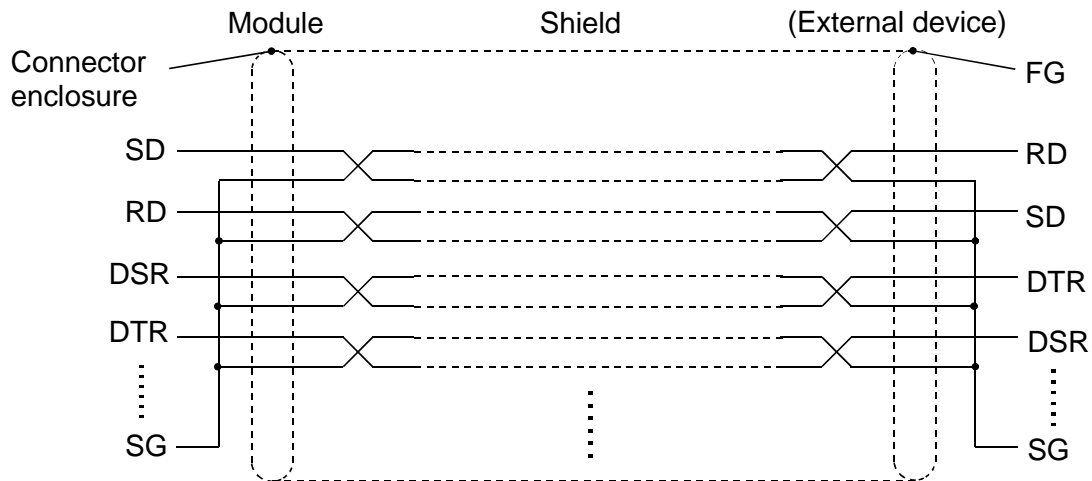

## 5.2 Connecting to the RS-422/485 line

This section explains the standard method for connecting the RS-422/485 line.

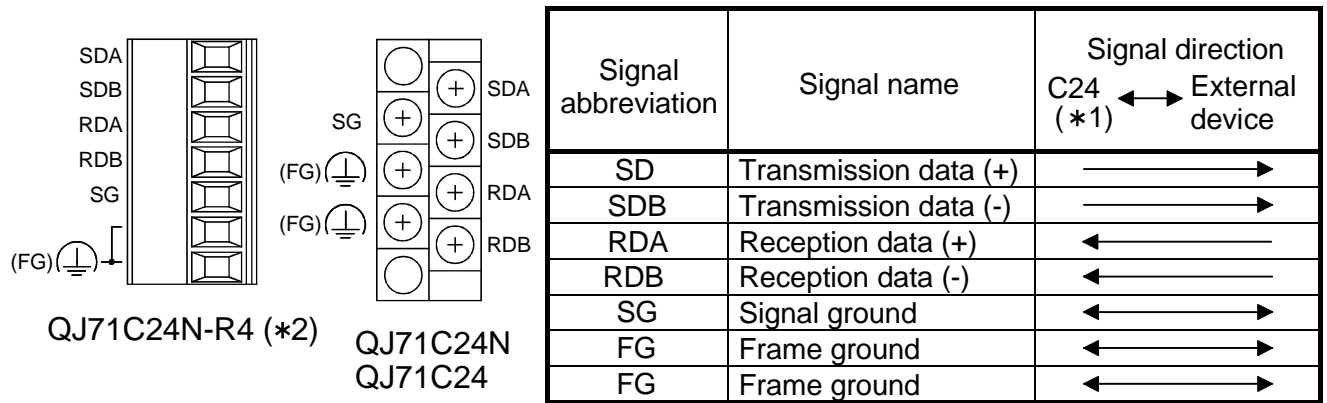

\*1 QJ71C24N, QJ71C24 : CH2 side, QJ71C24N-R4 : CH1/CH2 side

\*2 Connect the RS-422/485 line of QJ71C24N-R4 while paying full attention to the followings:

- 1) Use the RS-422/485 cable recommended in chapter 2. Performance specifications. Be sure to strip the outer insulation layer by 7mm before connecting the cable to the plug-in socket block.
- 2) When connecting the braided shield wire inside the RS-422/485 cable, use the plate terminal included with the product. The braided shield wire can be connected without the plate terminal. Four plate terminals are included to connect the FG terminals of the both stations. (Refer to section 5.2.(6))
- 3) When connecting the plug-in socket block to the QJ71C24N-R4, be sure to confirm the layout of the socket block and then insert it into the RS-422/485 connector on the QJ71C24N-R4.

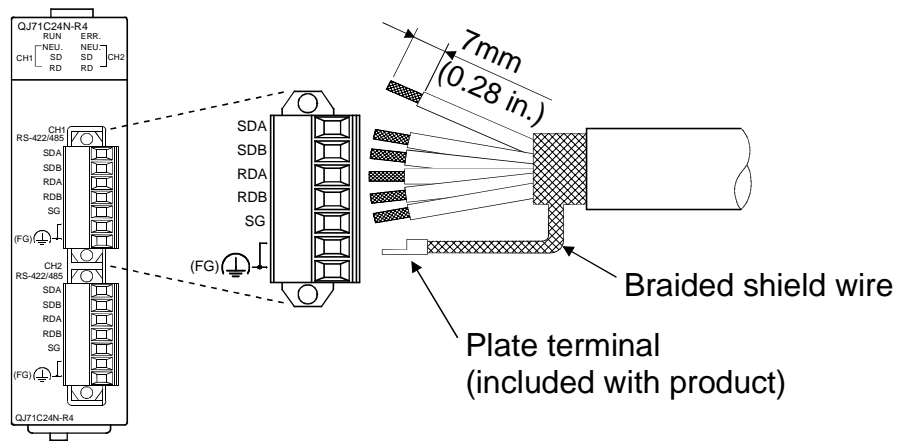

**POINT**

If the module is the first or last station on the RS-422/485 line, connect the following terminal resistor to the RS-422/485 interface with reference to the examples shown below. Data communication will be disturbed if a terminal resistor is not used.

- For RS-422 communication ..... 330 Ω 1/4 W
- For RS-485 communication ..... 110 Ω 1/2 W

The **R** in the examples shown below indicates a terminal resistor.

**(1) Example of one-to-one connection between an external device and the module (RS-422, RS-485)**

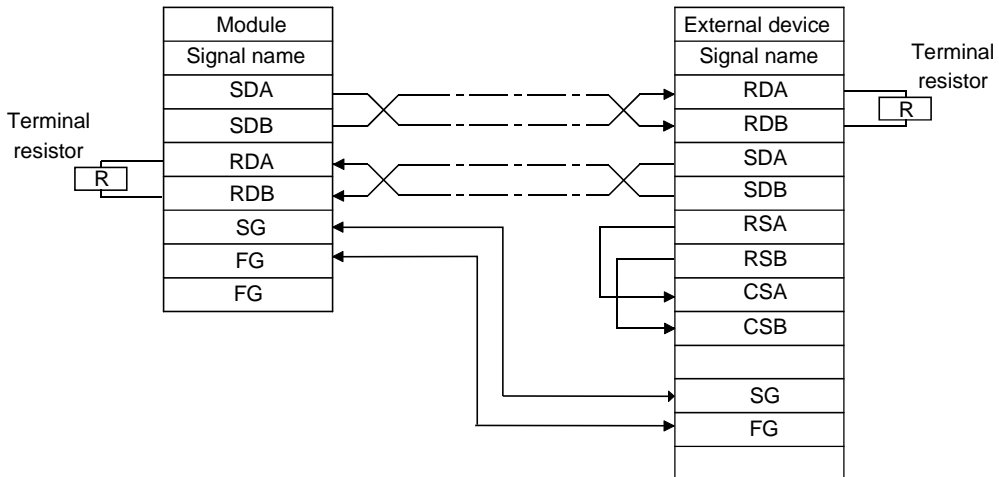

**(2) Example of one-to-n connection between an external device and the module (RS-485 between C24s)**

**(a) Connecting an external device and the module using RS-232**

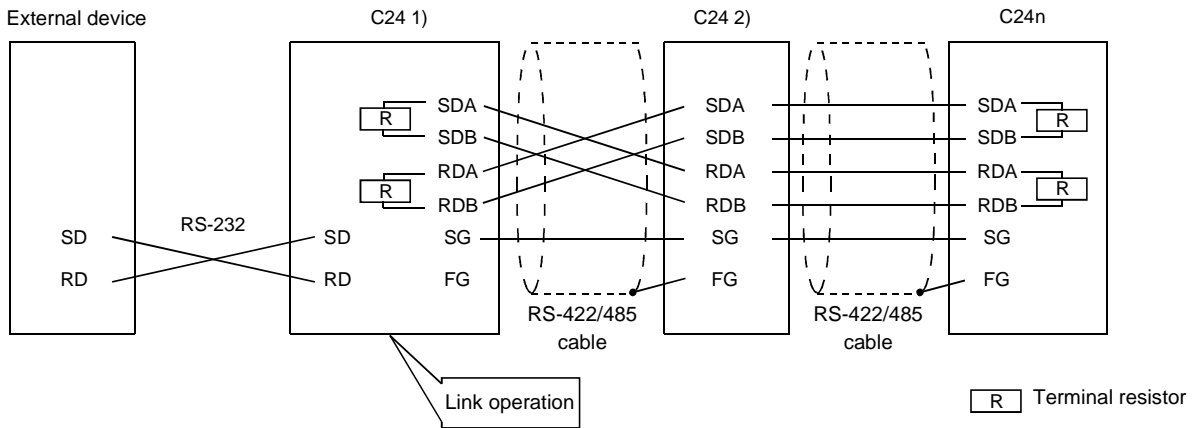

**(b) Connecting an external device and the module using RS-485**

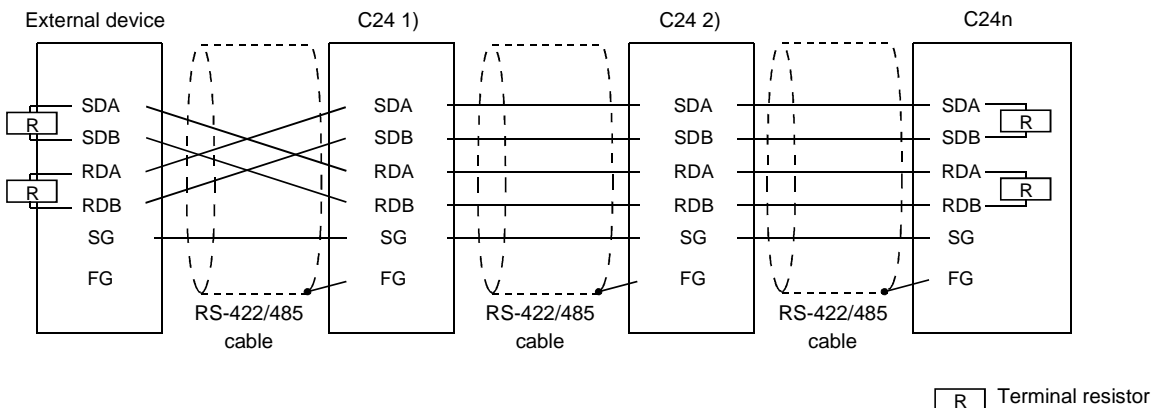



(3) Example of one-to-n connection between external devices and the module (RS-485)

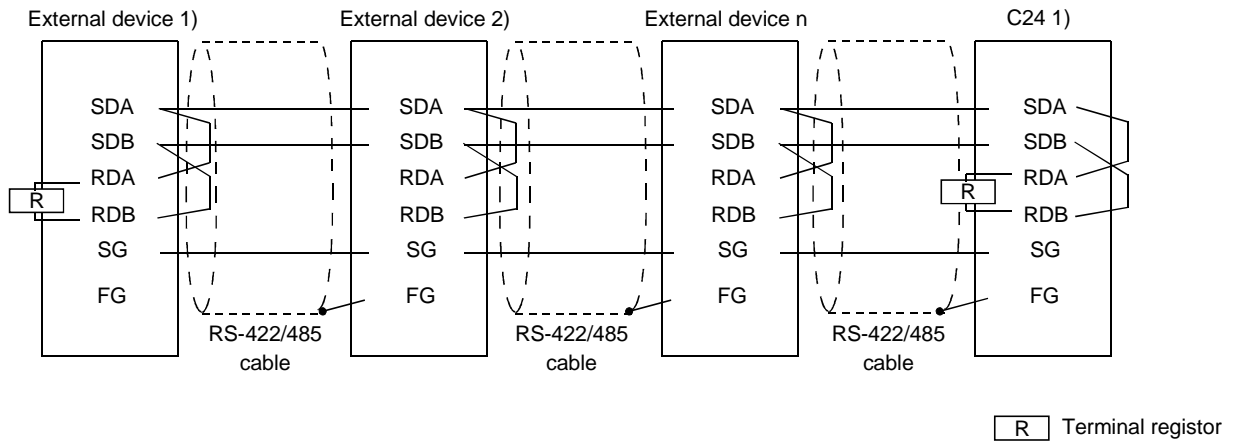

(4) Example of m-to-n connection between external devices and the modules (RS-485)

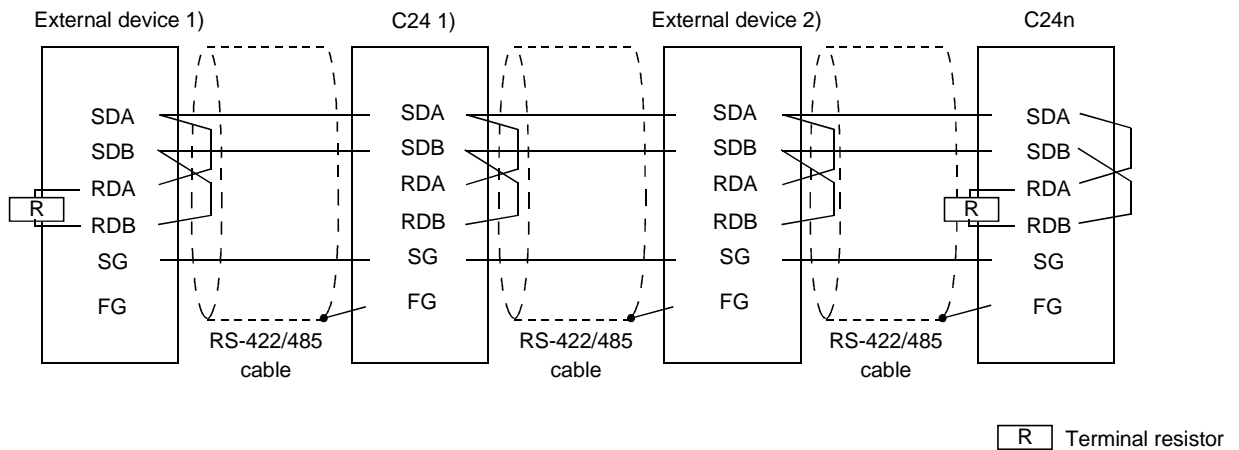

(5) Countermeasure for data reception error at the external device during RS-422/485 connection

If it is suspected that erroneous data may be received by the external devices while communicating data with the module through the RS-422/485 interface, connect pull-up and pull-down resistors (reference resistance: approx. 4.7 kΩ 1/4 W) to the external device.

These resistors will prevent data reception error.

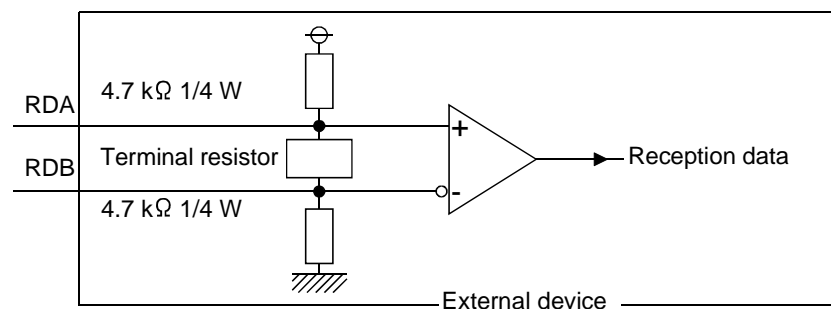

**POINT**

Data reception error will never occur if pull-up and pull-down resistors are connected to the external device.

(6) Connection precaution

(a) When connecting the SG and FG signals of the module to an external device, follow the specification of the external device.

(b) Connect the connector cable shield to either one of the FG terminals on the connected device.

(c) If data communication cannot be performed normally due to external noise even if the wiring is done properly, install wiring as follows:

- Connect the FGs of both stations using the connector cable shield. As for the connection on the external device, follow the specific manual.

Be sure to use the plate terminals included with the product when connecting the braided shield wire to the QJ71C24N-R4.

- Connect the FG of the module to the FG terminal of the power supply module for the station including the module or to the FG terminal on the control panel on which the PLC i.e., the station including the module is installed.
- Connect nA and nB in each signal of the connector cable as a pair.

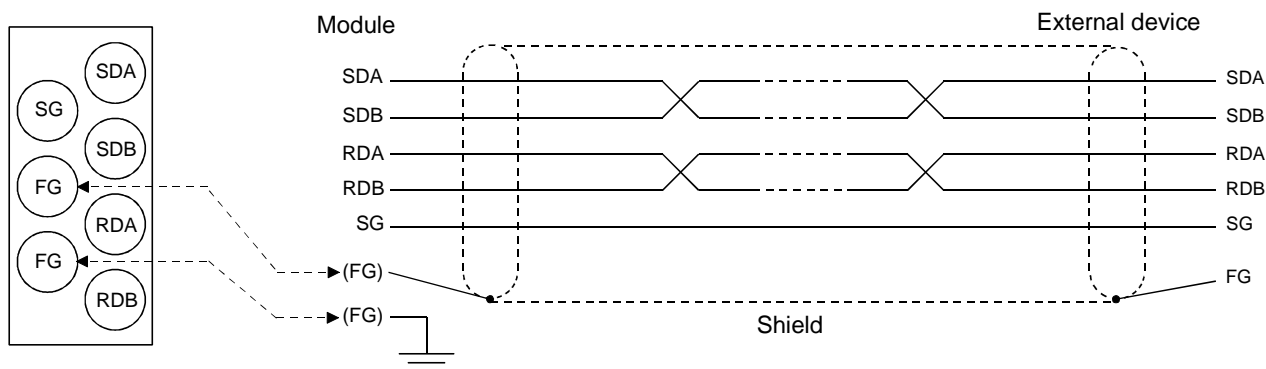

Corresponding to RS-422/485 terminal block and signal positions

POINT
1) When using the RS-232 to RS-422 converter or similar device for the device corresponding to the both-end station of the line according to the explanation of this section, set or connect a terminal resistor with the converter.
2) When connecting to the RS-422/485 interface of the module (including one-to-n, n to one and m to n connections), be sure to use the devices that meet the corresponding communication specifications.

## 6. Setting from GX Developer

To use a serial communication module, set the intelligent function module switches of GX Developer as follows:

(1) Switch 1 to 5

Set the transmission specifications and communication protocol for each interface according to the following table.

Switch number	Contents		Remarks
Switch 1	b15 to b8	b7 to b0	Refer to (a), (b)
	CH1 communication speed setting	CH1 transmission setting	
Switch 2	CH1 communication protocol setting		Refer to (c)
Switch 3	b15 to b8	b7 to b0	Refer to (a), (b)
	CH2 communication speed setting	CH2 transmission setting	
Switch 4	CH2 communication protocol setting		Refer to (c)
Switch 5	Station number setting		Refer to (d)

\* Refer to 2) for the settings when linking the operation of two interfaces connected to the serial communication modules.

(a) Transmission setting

Bit location	Contents	OFF	ON
b0	Operation setting	Independent	Linked
b1	Data bit	7 bits	8 bits
b2	Parity bit	No	Yes
b3	Even/odd parity	Odd	Even
b4	Stop bit	1 bit	2 bits
b5	Checksum code	No	Yes
b6	Write during RUN	Disabled	Enabled
b7	Change setting	Disabled	Enabled

\* The interface for which "GX Developer connection" is to be set in communication protocol setting must be set to OFF.

## (b) Communication speed setting

Communication speed (Unit: bps)	Bit location	Communication speed (Unit: bps)	Bit location
	b15 to b8		b15 to b8
50	0F <sub>H</sub>	14400	06 <sub>H</sub>
300	00 <sub>H</sub>	19200	07 <sub>H</sub>
600	01 <sub>H</sub>	28800	08 <sub>H</sub>
1200	02 <sub>H</sub>	38400	09 <sub>H</sub>
2400	03 <sub>H</sub>	57600	0A <sub>H</sub>
4800	04 <sub>H</sub>	115200	0B <sub>H</sub>
9600	05 <sub>H</sub>	230400	0C <sub>H</sub>

- \* Transmission speed of 230400 bps is available for only CH1 of the QJ71C24N(-R2/R4).
- \* When connecting external devices to both of two interfaces, the total of the communication speed should be 115200bps or less (230400 bps or less in the case of the QJ71C24N(-R2/R4)). When connecting an external device to either of two interfaces, the maximum of 115200 bps is available for the interface (the maximum of 230400 bps in the case of the QJ71C24N(-R2/R4)). In this case, set 300bps for the other interface to which no external device is connected.
- \* Set "00H" to the interface for which "GX Developer connection" is set in the communication protocol setting. Serial communication module will operate at the communication speed set on the GX Developer.

## (c) Communication protocol settings

Set number	Contents		Remarks
0000 <sub>H</sub>	GX Developer connection		GX Developer communication speed and transmission specifications are set automatically.
0001 <sub>H</sub>	MC protocol	Type 1	For communication by ASCII code using A-compatible 1C frame or QnA-compatible 2C/3C/4C frame. * Data communication is performed in the message format of the set type.
0002 <sub>H</sub>		Type 2	
0003 <sub>H</sub>		Type 3	
0004 <sub>H</sub>		Type 4	For communication by binary code using QnA-compatible 4C frame. * Data communication is performed in the message format of type 5.
0005 <sub>H</sub>		Type 5	
0006 <sub>H</sub>	Non-procedural protocol		For communication using non-procedural protocol.
0007 <sub>H</sub>	Bidirectional protocol		For communication using bidirectional protocol.
0008 <sub>H</sub>	For link settings		Set on the CH1 side when linking the operation of CH1 and CH2 interfaces. (Operated by the communication protocol on the CH2 side.)
0009 <sub>H</sub> to 000D <sub>H</sub>	Setting prohibited		—
000E <sub>H</sub>	ROM/RAM/switch test		For the module's self-diagnostic test.
000F <sub>H</sub>	Module loop back test		For confirmation of module interface operations.

- \* When no external device is connected to the interface, be sure to set its communication protocol between "0" and "7".
- \* The communication protocol for the interfaces of both CH1 and CH2 can be set to "0" at the same time.

(d) Station number settings

- 1) Set a value between 0 and 31 to the station number for the module used in communication via MC protocol.
- 2) For one to one connection between an external device and the module, set as 0.

(2) Link operation settings

To link the operation of two interfaces connected to the module, set the related switches as follows.

Switch number		Data item	Set value	
Switch 1	CH1 side	Transmission settings	Operation settings	b0=OFF
			Data bit settings	Set the switches on the CH1 side and CH2 side to the same specifications.
		:		
		Communication speed settings	As per the external device.	
Switch 2		Communication protocol settings	0008H	
Switch 3	CH2 side	Transmission setting	Operation settings	b0=ON
			Data bit settings	Set the switches on the CH1 side and CH2 side to the same specifications.
		:		
		Communication speed settings	As per the external device.	
Switch 4		Communication protocol settings (*1)	0000H to 0007H	
Switch 5		Station number settings	Set as per (1) (d).	

\*1: Set the number for the function on the CH2 side.

**REMARK**

In the following cases, the module can not perform link operation, so please do not use the above setting.

- 1) When using the QJ71C24N-R2 or QJ71C24-R2.
- 2) When the external device is not connected to either interface.
- 3) When communicating data with a bidirectional protocol.
- 4) When communicating data with the external devices connected to the two interfaces (not liked) by using the function (MC protocol/non-procedural protocol) set in each communication protocol setting.
- 5) When communicating data using the modem function.

## 7. External Dimensions

### (1) QJ71C24N, QJ71C24

The following diagram shows the QJ71C24 and QJ71C24N. The dimensions of the QJ71C24 are the same as QJ71C24N (except for model name).

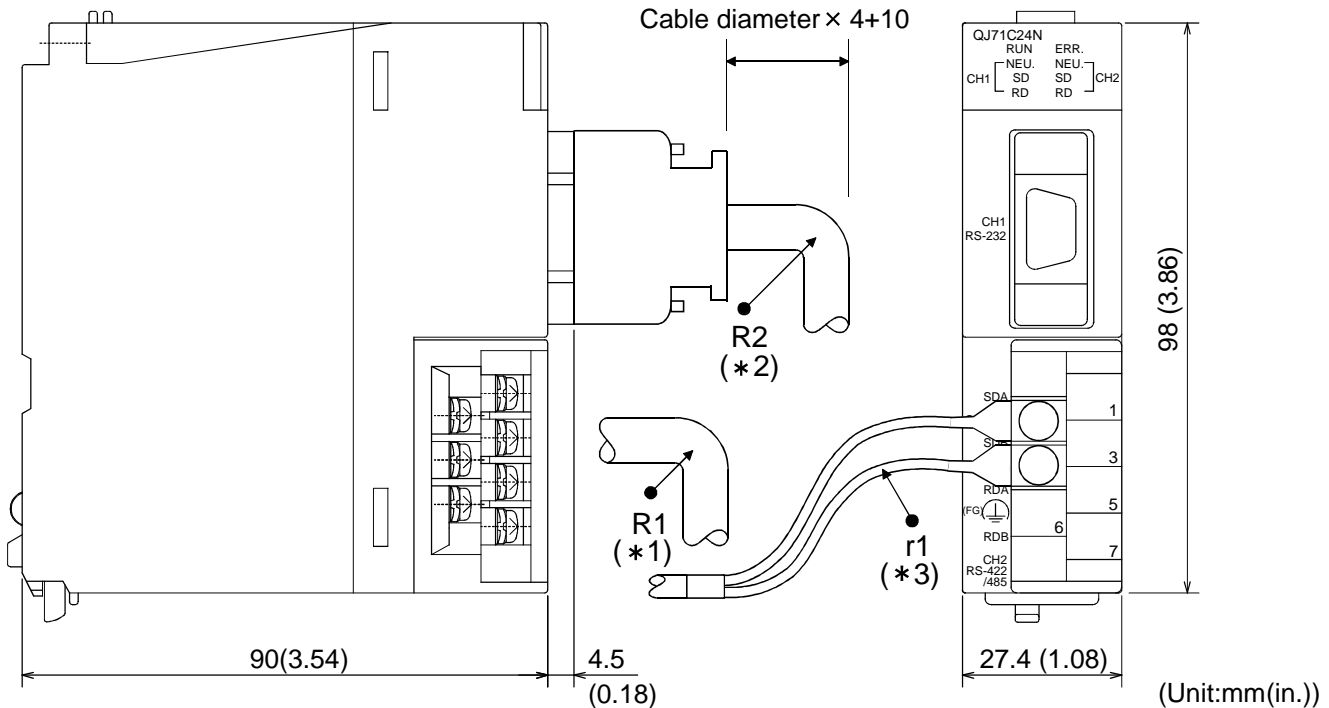

\*1: R1 (Bending radius near terminal block) : Cable diameter  $\times$  4

\*2: R2 (Bending radius near connector) : Cable diameter  $\times$  4

\*3: r1 (Bending radius near crimp contact) : Connectable as long as not bended externally

### (2) QJ71C24N-R2, QJ71C24-R2

The following diagram shows the QJ71C24-R2 and QJ71C24N-R2. The dimensions of the QJ71C24-R2 are the same as QJ71C24N-R2 (except for model name).

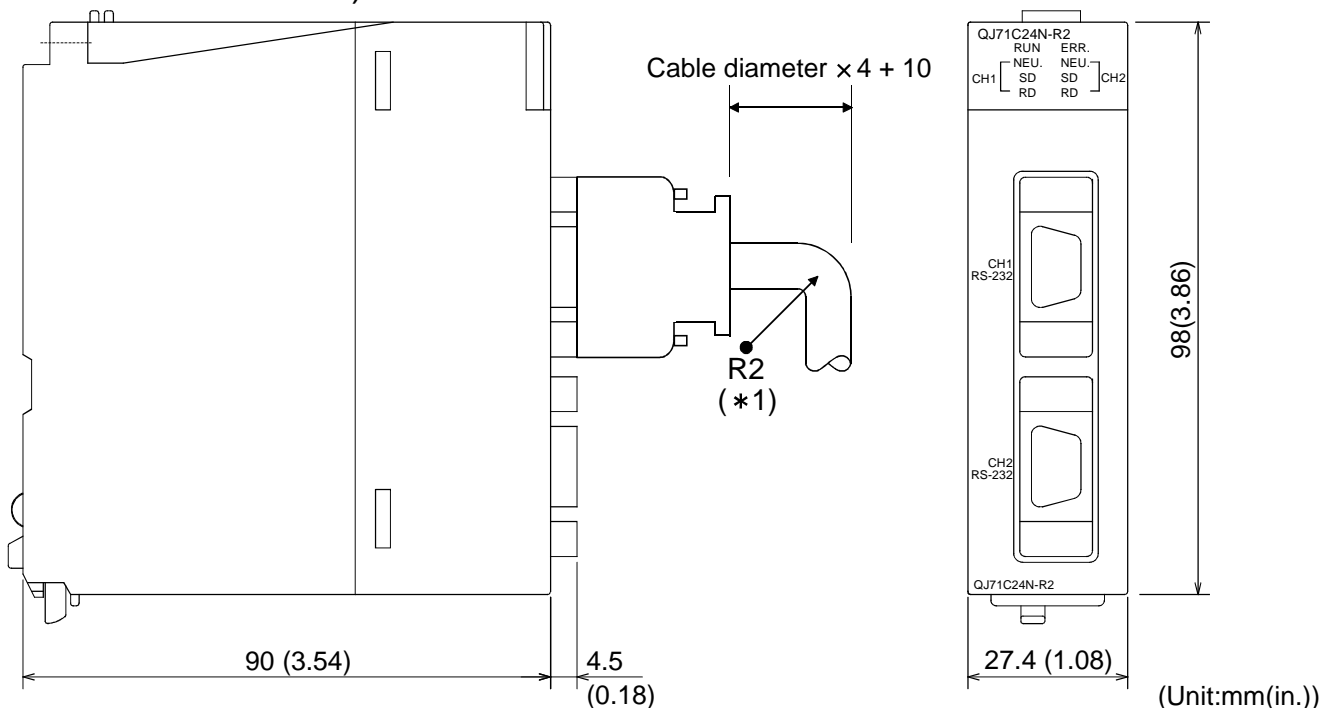

\*1: R2 (Bending radius near connector) : Cable diameter  $\times$  4

### (3) QJ71C24N-R4

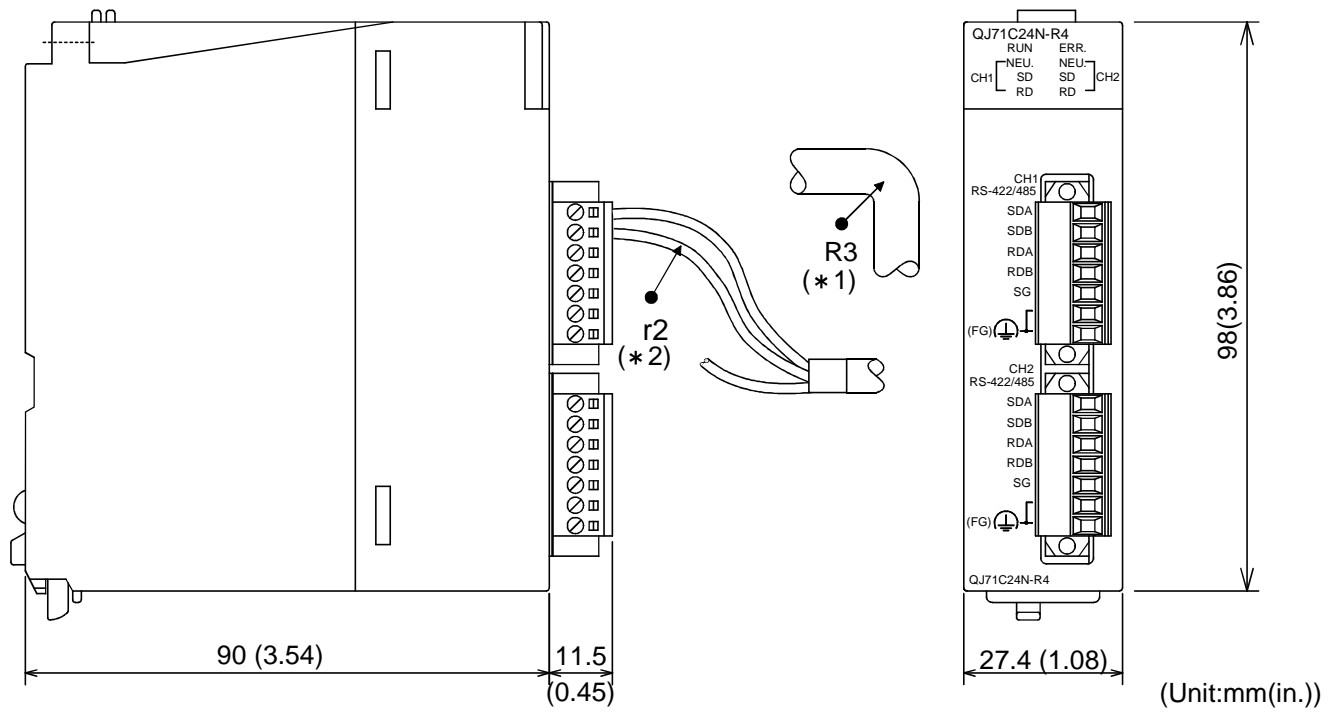

- \*1:  $R3$  (Bending radius near the plug-in socket block): cable diameter  $\times 4$
- \*2:  $r2$  (Bending radius near the wire connection) : connectable as long as not bended extremely

## Warranty

Mitsubishi will not be held liable for damage caused by factors found not to be the cause of Mitsubishi; machine damage or lost profits caused by faults in the Mitsubishi products; damage, secondary damage, accident compensation caused by special factors unpredictable by Mitsubishi; damages to products other than Mitsubishi products; and to other duties.

### For safe use

- This product has been manufactured as a general-purpose part for general industries, and has not been designed or manufactured to be incorporated in a device or system used in purposes related to human life.
- Before using the product for special purposes such as nuclear power, electric power, aerospace, medicine or passenger movement vehicles, consult with Mitsubishi.
- This product has been manufactured under strict quality control. However, when installing the product where major accidents or losses could occur if the product fails, install appropriate backup or failsafe functions in the system.

Country/Region	Sales office/Tel	Country/Region	Sales office/Tel
U.S.A	Mitsubishi Electric Automation Inc. 500 Corporate Woods Parkway Vernon Hills, IL 60061 Tel : +1-847-478-2100	Hong Kong	Ryoden Automation Ltd. 10th Floor, Manulife Tower, 169 Electric Road, North Point, HongKong Tel : +852-2887-8870
Brazil	MELCO-TEC Rep. Com.e Assessoria Tecnica Ltda. AV. Paulista 1471, Conj. 308, Sao Paulo City, Sao Paulo State, Brazil Tel : +55-11-283-2423	China	Ryoden Automation Shanghai Ltd. 3F Block5 Building Automation Instrumentation Plaza 103 Cao Bao Rd. Shanghai 200233 China Tel : +86-21-6475-3228
Germany	Mitsubishi Electric Europe B.V. German Branch Gothaer Strasse 8 D-40880 Ratingen, GERMANY Tel : +49-2102-486-0	Taiwan	Setsuyo Enterprise Co., Ltd. 6F., No.105 Wu-Kung 3rd.RD, Wu-Ku Hsiang, Taipei Hsine, Taiwan Tel : +886-2-2299-2499
U.K	Mitsubishi Electric Europe B.V. UK Branch Travellers Lane, Hatfield, Herts., AL10 8XB,UK Tel : +44-1707-276100	Korea	HAN NEUNG TECHNO CO.,LTD. 1F Dong Seo Game Channel Bldg., 660-11, Deungchon-dong Kangsec-ku, Seoul, Korea Tel : +82-2-3660-9552
Italy	Mitsubishi Electric Europe B.V. Italian Branch Centro Dir. Colleoni, Pal. Perseo-Ingr.2 Via Paracelso 12, 20041 Agrate B., Milano, Italy Tel : +39-039-6053344	Singapore	Mitsubishi Electric Asia Pte, Ltd. 307 ALEXANDRA ROAD #05-01/02, MITSUBISHI ELECTRIC BUILDING SINGAPORE 159943 Tel : +65-6473-2308
Spain	Mitsubishi Electric Europe B.V. Spanish Branch Carretera de Rubi 76-80 08190 - Sant Cugat del Valles, Barcelona, Spain Tel : +34-93-565-3131	Thailand	F. A. Tech Co.,Ltd. 898/28,29,30 S.V.City Building,Office Tower 2,Floor 17-18 Rama 3 Road, Bangkokpang, Yannawa, Bangkok 10120 Tel : +66-2-682-6522
France	Mitsubishi Electric Europe B.V. French Branch 25 Boulevard des Bouvets, F-92741 Nanterre Cedex, France TEL: +33-1-5568-5568	Indonesia	P.T. Autoteknindo SUMBER MAKMUR Jl. Muara Karang Selatan Block A Utara No.1 Kav. No.11 Kawasan Industri/ Pergudangan Jakarta - Utara 14440 Tel : +62-21-663-0833
South Africa	Circuit Breaker Industries LTD. Tripswitch Drive, Elandsfontein Gauteng, South Africa Tel : +27-11-928-2000	India	Messung Systems Put,Ltd. Electronic Sadan NO:111 Unit No15, M.I.D.C BHOSARI,PUNE-411026 Tel : +91-20-712-2807
		Australia	Mitsubishi Electric Australia Pty. Ltd. 348 Victoria Road, PostalBag, No 2, Rydalmere, N.S.W 2116, Australia Tel : +61-2-9684-7777

## MITSUBISHI ELECTRIC CORPORATION

HEAD OFFICE : 1-8-12, OFFICE TOWER Z 14F HARUMI CHUO-KU 104-6212, JAPAN  
NAGOYA WORKS : 1-14, YADA-MINAMI5, HIGASHI-KU, NAGOYA, JAPAN

When exported from Japan, this manual does not require application to the Ministry of Economy, Trade and Industry for service transaction permission.

Specifications subject to change without notice.  
Printed in Japan on recycled paper.





**HEADQUARTERS**

MITSUBISHI ELECTRIC EUROPE B.V. **EUROPE**  
 German Branch  
 Gothaer Straße 8  
**D-40880 Ratingen**  
 Phone: +49 (0)2102 / 486-0  
 Fax: +49 (0)2102 / 486-1120

MITSUBISHI ELECTRIC EUROPE B.V.-org.sl. **CZECH REP.**  
 Czech Branch  
 Avenir Business Park, Radlická 714/113a  
**CZ-158 00 Praha 5**  
 Phone: +420 - 251 551 470  
 Fax: +420 - 251-551-471

MITSUBISHI ELECTRIC EUROPE B.V. **FRANCE**  
 French Branch  
 25, Boulevard des Bouvets  
**F-92741 Nanterre Cedex**  
 Phone: +33 (0)1 / 55 68 55 68  
 Fax: +33 (0)1 / 55 68 57 57

MITSUBISHI ELECTRIC EUROPE B.V. **IRELAND**  
 Irish Branch  
 Westgate Business Park, Ballymount  
**IRL-Dublin 24**  
 Phone: +353 (0)1 4198800  
 Fax: +353 (0)1 4198890

MITSUBISHI ELECTRIC EUROPE B.V. **ITALY**  
 Italian Branch  
 Viale Colleoni 7  
**I-20041 Agrate Brianza (MB)**  
 Phone: +39 039 / 60 53 1  
 Fax: +39 039 / 60 53 312

MITSUBISHI ELECTRIC EUROPE B.V. **POLAND**  
 Poland Branch  
 Krakowska 50  
**PL-32-083 Balice**  
 Phone: +48 (0)12 / 630 47 00  
 Fax: +48 (0)12 / 630 47 01

MITSUBISHI ELECTRIC EUROPE B.V. **RUSSIA**  
 52, bid. 3 Kosmodamianskaya nab 8 floor  
**RU-115054 Moscow**  
 Phone: +7 495 721-2070  
 Fax: +7 495 721-2071

MITSUBISHI ELECTRIC EUROPE B.V. **SPAIN**  
 Spanish Branch  
 Carretera de Rubí 76-80  
**E-08190 Sant Cugat del Vallés (Barcelona)**  
 Phone: 902 131121 // +34 935653131  
 Fax: +34 935891579

MITSUBISHI ELECTRIC EUROPE B.V. **UK**  
 UK Branch  
 Travellers Lane  
**UK-Hatfield, Herts. AL10 8XB**  
 Phone: +44 (0)1707 / 27 61 00  
 Fax: +44 (0)1707 / 27 86 95

MITSUBISHI ELECTRIC CORPORATION **JAPAN**  
 Office Tower "Z" 14 F  
 8-12,1 chome, Harumi Chuo-Ku  
**Tokyo 104-6212**  
 Phone: +81 3 622 160 60  
 Fax: +81 3 622 160 75

MITSUBISHI ELECTRIC AUTOMATION, Inc. **USA**  
 500 Corporate Woods Parkway  
**Vernon Hills, IL 60061**  
 Phone: +1 847 478 21 00  
 Fax: +1 847 478 22 53

**EUROPEAN REPRESENTATIVES**

GEVA **AUSTRIA**  
 Wiener Straße 89  
**AT-2500 Baden**  
 Phone: +43 (0)2252 / 85 55 20  
 Fax: +43 (0)2252 / 488 60

TEHNIKON **BELARUS**  
 Oktyabrskaya 16/5, Off. 703-711  
**BY-220030 Minsk**  
 Phone: +375 (0)17 / 210 46 26  
 Fax: +375 (0)17 / 210 46 26

ESCO DRIVES & AUTOMATION **BELGIUM**  
 Culliganlaan 3  
**BE-1831 Diegem**  
 Phone: +32 (0)2 / 717 64 30  
 Fax: +32 (0)2 / 717 64 31

Koning & Hartman b.v. **BELGIUM**  
 Woluwelaan 31  
**BE-1800 Vilvoorde**  
 Phone: +32 (0)2 / 257 02 40  
 Fax: +32 (0)2 / 257 02 49

INEA BH d.o.o. **BOSNIA AND HERZEGOVINA**  
 Aleja Lipa 56  
**BA-71000 Sarajevo**  
 Phone: +387 (0)33 / 921 164  
 Fax: +387 (0)33 / 524 539

AKHNATON **BULGARIA**  
 4 Andrej Ljapchev Blvd. Pb 21  
**BG-1756 Sofia**  
 Phone: +359 (0)2 / 817 6044  
 Fax: +359 (0)2 / 97 44 06 1

INEA CR d.o.o. **CROATIA**  
 Losinjska 4 a  
**HR-10000 Zagreb**  
 Phone: +385 (0)1 / 36 940 -01 / -02 / -03  
 Fax: +385 (0)1 / 36 940 -03

AutoCont C.S. s.r.o. **CZECH REPUBLIC**  
 Technologická 374/6  
**CZ-708 00 Ostrava-Pustkovec**  
 Phone: +420 595 691 150  
 Fax: +420 595 691 199

Beijer Electronics A/S **DENMARK**  
 Lykkegårdsvej 17  
**DK-4000 Roskilde**  
 Phone: +45 (0)46 / 75 76 66  
 Fax: +45 (0)46 / 75 56 26

Beijer Electronics Eesti OÜ **ESTONIA**  
 Pärnu mnt.160i  
**EE-11317 Tallinn**  
 Phone: +372 (0)6 / 51 81 40  
 Fax: +372 (0)6 / 51 81 49

Beijer Electronics OY **FINLAND**  
 Peltoie 37  
**FIN-28400 Ulvila**  
 Phone: +358 (0)207 / 463 540  
 Fax: +358 (0)207 / 463 541

UTEKO **GREECE**  
 5, Mavrogenous Str.  
**GR-18542 Piraeus**  
 Phone: +30 211 / 1206 900  
 Fax: +30 211 / 1206 999

MELTRADE Kft. **HUNGARY**  
 Fertő utca 14.  
**HU-1107 Budapest**  
 Phone: +36 (0)1 / 431-9726  
 Fax: +36 (0)1 / 431-9727

Beijer Electronics SIA **LATVIA**  
 Rītausmas iela 23  
**LV-1058 Rīga**  
 Phone: +371 (0)784 / 2280  
 Fax: +371 (0)784 / 2281

Beijer Electronics UAB **LITHUANIA**  
 Savanoriu Pr. 187  
**LT-02300 Vilnius**  
 Phone: +370 (0)5 / 232 3101  
 Fax: +370 (0)5 / 232 2980

**EUROPEAN REPRESENTATIVES**

ALFATRADE Ltd. **MALTA**  
 99, Paola Hill  
**Malta- Paola PLA 1702**  
 Phone: +356 (0)21 / 697 816  
 Fax: +356 (0)21 / 697 817

INTEHSIS srl **MOLDOVA**  
 bld. Traian 23/1  
**MD-2060 Kishinev**  
 Phone: +373 (0)22 / 66 4242  
 Fax: +373 (0)22 / 66 4280

HIFLEX AUTOM.TECHNIEK B.V. **NETHERLANDS**  
 Wolweverstraat 22  
**NL-2984 CD Ridderkerk**  
 Phone: +31 (0)180 - 46 60 04  
 Fax: +31 (0)180 - 44 23 55

Koning & Hartman b.v. **NETHERLANDS**  
 Haarlbergweg 21-23  
**NL-1101 CH Amsterdam**  
 Phone: +31 (0)20 / 587 76 00  
 Fax: +31 (0)20 / 587 76 05

Beijer Electronics AS **NORWAY**  
 Postboks 487  
**NO-3002 Drammen**  
 Phone: +47 (0)32 / 24 30 00  
 Fax: +47 (0)32 / 84 85 77

Fonseca S.A. **PORTUGAL**  
 R. João Francisco do Casal 87/89  
**PT - 3801-997 Aveiro, Esgueira**  
 Phone: +351 (0)234 / 303 900  
 Fax: +351 (0)234 / 303 910

Sirius Trading & Services srl **ROMANIA**  
 Aleea Lacul Morii Nr. 3  
**RO-060841 Bucuresti, Sector 6**  
 Phone: +40 (0)21 / 430 40 06  
 Fax: +40 (0)21 / 430 40 02

Craft Con. & Engineering d.o.o. **SERBIA**  
 Bulevar Svetog Cara Konstantina 80-86  
**SER-18106 Nis**  
 Phone: +381 (0)18 / 292-24-4/5  
 Fax: +381 (0)18 / 292-24-4/5

INEA SR d.o.o. **SERBIA**  
 Izletnicka 10  
**SER-113000 Smederevo**  
 Phone: +381 (0)26 / 617 163  
 Fax: +381 (0)26 / 617 163

SIMAP s.r.o. **SLOVAKIA**  
 Jána Derku 1671  
**SK-911 01 Trenčín**  
 Phone: +421 (0)32 743 04 72  
 Fax: +421 (0)32 743 75 20

PROCONT, spol. s r.o. Prešov **SLOVAKIA**  
 Kúpeľná 1/A  
**SK-080 01 Prešov**  
 Phone: +421 (0)51 7580 611  
 Fax: +421 (0)51 7580 650

INEA d.o.o. **SLOVENIA**  
 Stegne 11  
**SI-1000 Ljubljana**  
 Phone: +386 (0)1 / 513 8100  
 Fax: +386 (0)1 / 513 8170

Beijer Electronics AB **SWEDEN**  
 Box 426  
**SE-20124 Malmö**  
 Phone: +46 (0)40 / 35 86 00  
 Fax: +46 (0)40 / 93 23 01

Omni Ray AG **SWITZERLAND**  
 Im Schörl 5  
**CH-8600 Dübendorf**  
 Phone: +41 (0)44 / 802 28 80  
 Fax: +41 (0)44 / 802 28 28

GTS **TURKEY**  
 Bayraktar Bulvarı Nutuk Sok. No:5  
**TR-34775 Yukarı Dudullu-Ümraniye-İSTANBUL**  
 Phone: +90 (0)216 526 39 90  
 Fax: +90 (0)216 526 39 95

CSC Automation Ltd. **UKRAINE**  
 4-B, M. Raskovoyi St.  
**UA-02660 Kiev**  
 Phone: +380 (0)44 / 494 33 55  
 Fax: +380 (0)44 / 494-33-66

**EURASIAN REPRESENTATIVES**

Kazpromautomatiks Ltd. **KAZAKHSTAN**  
 Mustafina Str. 7/2  
**KAZ-470046 Karaganda**  
 Phone: +7 7212 / 50 11 50  
 Fax: +7 7212 / 50 11 50

**MIDDLE EAST REPRESENTATIVES**

ILAN & GAVISH Ltd. **ISRAEL**  
 24 Shenkar St., Kiryat Arie  
**IL-49001 Petah-Tiqva**  
 Phone: +972 (0)3 / 922 18 24  
 Fax: +972 (0)3 / 924 0761

TEXEL ELECTRONICS Ltd. **ISRAEL**  
 2 Ha'umanut, P.O.B. 6272  
**IL-42160 Netanya**  
 Phone: +972 (0)9 / 863 39 80  
 Fax: +972 (0)9 / 885 24 30

CEG INTERNATIONAL **LEBANON**  
 Cebaco Center/Block A Autostrade DORA  
**Lebanon - Beirut**  
 Phone: +961 (0)1 / 240 430  
 Fax: +961 (0)1 / 240 438

**AFRICAN REPRESENTATIVE**

CBI Ltd. **SOUTH AFRICA**  
 Private Bag 2016  
**ZA-1600 Isando**  
 Phone: +27 (0)11 / 977 0770  
 Fax: +27 (0)11 / 977 0761