

# CC-Link IE Field Network Waterproof/Dustproof Remote I/O Module FB Library Reference Manual

Applicable modules:

NZ2GF12A4-16D, NZ2GF12A2-16T, NZ2GF12A42-16DT,  
NZ2GF12A4-16DE, NZ2GF12A2-16TE, NZ2GF12A42-16DTE

## < CONTENTS >

Reference Manual Revision History .....	2
1. Overview .....	3
1.1. Overview of the FB Library .....	3
1.2. Function of the FB Library .....	3
1.3. System Configuration Examples .....	4
1.4. Setting the CC-Link IE Field Network Master/Local Module .....	5
1.5. Setting Global Labels .....	9
1.6. Creating Interlock Program .....	10
1.6.1. Cyclic Transmission Program .....	10
1.7. Relevant Manuals .....	11
1.8. Note .....	11
2. Details of the FB Library .....	12
2.1. M+NZ2GF12A16_InitialProcessing (Initial processing) .....	12
2.2. M+NZ2GF12A16_SetOpeCondition (Operation condition setting) .....	18
2.3. M+NZ2GF12A16_ErrorOperation (Error operation) .....	24
Appendix 1. When Using the FB for 2 or More Master/Local Modules .....	30
Appendix 1.1. Entering Network Parameters .....	31
Appendix 1.2. Entering Global Labels .....	35
Appendix 1.3. Copying MELSOFT Library to Create an FB for the Second Module .....	36
Appendix 1.4. Replacing Devices to Create the FB for the Second Module .....	38
Appendix 2. FB Library Application Examples .....	40

## Reference Manual Revision History

Reference Manual Number	Date	Description
FBM-M187-A	2017/01	First edition

## 1. Overview

### 1.1. Overview of the FB Library

This FB library is for using NZ2GF12A4-16D, NZ2GF12A2-16T, NZ2GF12A42-16DT, NZ2GF12A4-16DE, NZ2GF12A2-16TE, and NZ2GF12A42-16DTE CC-Link IE Field Network remote I/O modules.

### 1.2. Function of the FB Library

Item	Description
M+NZ2GF12A16_InitialProcessing	Performs the initial processing after power-on.
M+NZ2GF12A16_SetOpeCondition	Performs the operation condition setting.
M+NZ2GF12A16_ErrorOperation	Monitors the error status and warning status, and performs error clear.

### 1.3. System Configuration Examples

The following examples show system configurations when using the I/O modules (NZ2GF12A4-16D, NZ2GF12A2-16T, NZ2GF12A42-16DT, NZ2GF12A4-16DE, NZ2GF12A2-16TE, NZ2GF12A42-16DTE) as remote device stations.

#### (1) Q series system configuration

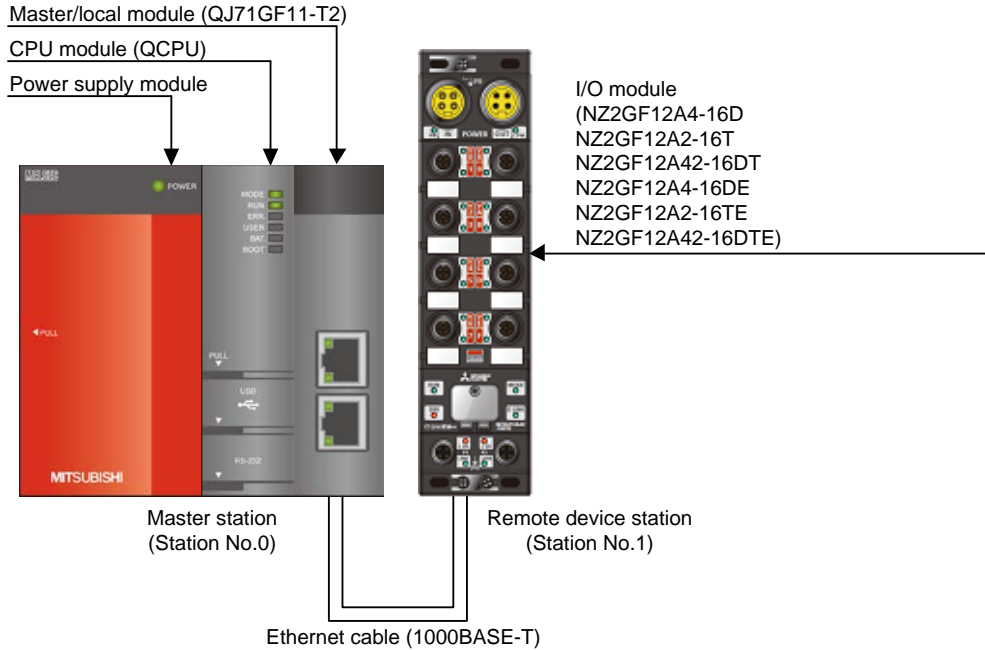

#### (2) L series system configuration

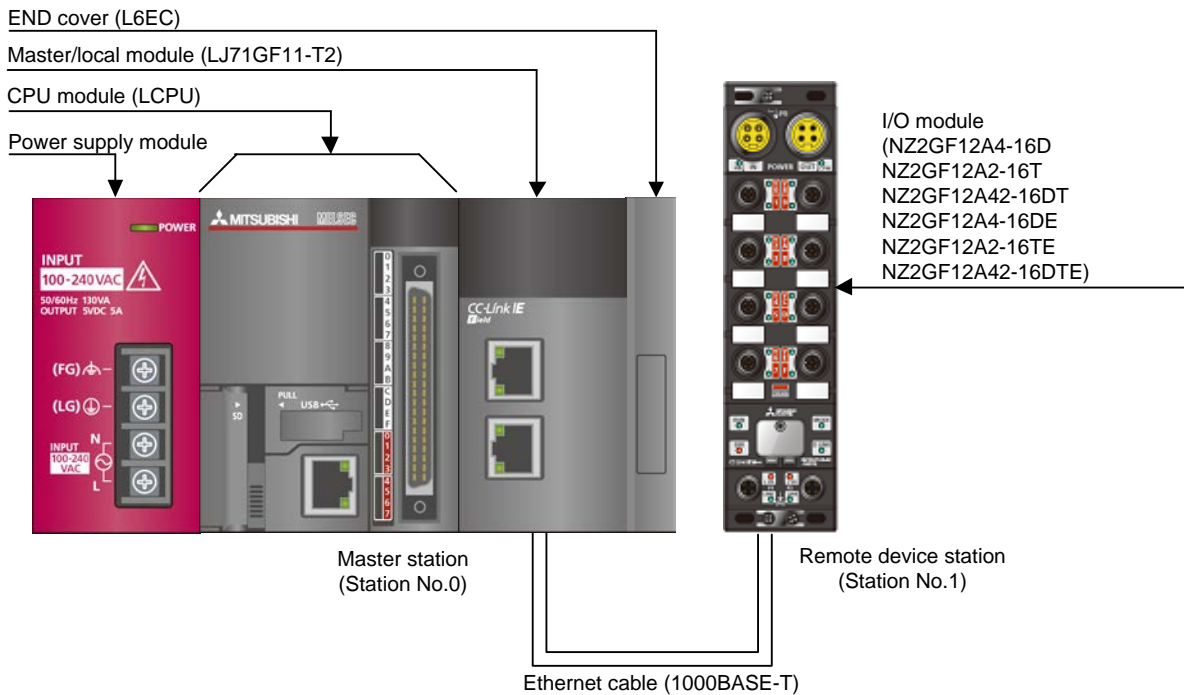

#### 1.4. Setting the CC-Link IE Field Network Master/Local Module

This section explains the settings of CC-Link IE Field Network master/local module based on Section "1.3 System Configuration Examples". Set the following items using GX Works2.

##### (1) Network parameters

Item	Description
Network Type	Select the CC IE Field (Master Station).
Start I/O No.	Set the start I/O number of the master/local module in increments of 16 points. Set "0000".
Network No.	Set the network number of the master/local module. Set "1".

\* Select this checkbox.



Set network configuration setting in CC IE Field configuration window

	Module 1	Module 2
Network Type	CC IE Field (Master Station)	None
Start I/O No.	0000	
Network No.	1	
Total Stations	0	
Group No.		
Station No.	0	
Mode	Online (Normal Mode)	
	<a href="#">CC IE Field Configuration Setting</a>	
	<a href="#">Network Operation Settings</a>	
	<a href="#">Refresh Parameters</a>	
	<a href="#">Interrupt Settings</a>	
	Specify Station No. by Parameter	

(2) CC IE Field configuration setting

Item	Description
Station No.	Set the station number of the remote device station connected to the master station. Set "1".
Station Type	Set the station type of the remote device station connected to the master station. Set "Remote Device Station".
RX/Ry Setting	Set assignment for RX/Ry for the remote device station connected to the master station. (a) Start Set "0000". (b) End Set "000F".
RWw/RWr Setting	Set assignment for RWw/RWr for the remote device station connected to the master station. (a) Start Set "0000". (b) End Set "000B".

[When using NZ2GF12A4-16D]

	No.	Model Name	STA#	Station Type	RX/Ry Setting			RWw/RWr Setting			Refresh Device
					Points	Start	End	Points	Start	End	RX
	0	Host Station	0	Master Station							
	1	NZ2GF12A4-16D	1	Remote Device Station	16	0000	000F	12	0000	000B	M1024 (16 points)

\*Set the module to be used according to the environment.

(3) Refresh parameter setting

Item	Description	Setting value
Transfer SB	Select the link refresh range of SB device.	<ul style="list-style-type: none"> <li>•"Link Side Points" : 512</li> <li>•"Link Side Start" : 0000</li> <li>•"PLC Side Dev. Name" : SB</li> <li>•"PLC Side Start" : 0000</li> </ul>
Transfer SW	Select the link refresh range of SW device.	<ul style="list-style-type: none"> <li>•"Link Side Points" : 512</li> <li>•"Link Side Start" : 0000</li> <li>•"PLC Side Dev. Name" : SW</li> <li>•"PLC Side Start" : 0000</li> </ul>
Transfer 1	Select the link refresh range of RX device.	<ul style="list-style-type: none"> <li>•"Link Side Dev. Name" : RX</li> <li>•"Link Side Points" : 16</li> <li>•"Link Side Start" : 0000</li> <li>•"PLC Side Dev. Name" : M</li> <li>•"PLC Side Start" : 1024</li> </ul>
Transfer 2	Select the link refresh range of RY device.	<ul style="list-style-type: none"> <li>•"Link Side Dev. Name" : RY</li> <li>•"Link Side Points" : 16</li> <li>•"Link Side Start" : 0000</li> <li>•"PLC Side Dev. Name" : M</li> <li>•"PLC Side Start" : 2048</li> </ul>
Transfer 3	Select the link refresh range of RWr device.	<ul style="list-style-type: none"> <li>•"Link Side Dev. Name" : RWr</li> <li>•"Link Side Points" : 12</li> <li>•"Link Side Start" : 0000</li> <li>•"PLC Side Dev. Name" : W</li> <li>•"PLC Side Start" : 1000</li> </ul>
Transfer 4	Select the link refresh range of RWw device.	<ul style="list-style-type: none"> <li>•"Link Side Dev. Name" : RWw</li> <li>•"Link Side Points" : 12</li> <li>•"Link Side Start" : 0000</li> <li>•"PLC Side Dev. Name" : W</li> <li>•"PLC Side Start" : 1100</li> </ul>

\* Make sure to set "0000" for Start of Link Side.

\* Change the Points of Link Side and Dev. Name and Start of PLC Side according to the system.

They must be the same as for "M\_F\_RWr" and "M\_F\_RWw" devices of the global label setting.

Assignment Method

- Points/Start
- Start/End

\* Set 0000 for the start address of Link Side.

	Link Side					PLC Side			
	Dev. Name	Points	Start	End		Dev. Name	Points	Start	End
Transfer SB	SB	512	0000	01FF	↕	SB	512	0000	01FF
Transfer SW	SW	512	0000	01FF	↕	SW	512	0000	01FF
Transfer 1	RX	16	0000	000F	↕	M	16	1024	1039
Transfer 2	RY	16	0000	000F	↕	M	16	2048	2063
Transfer 3	RWr	12	0000	000B	↕	W	12	001000	00100B
Transfer 4	RWw	12	0000	000B	↕	W	12	001100	00110B
Transfer 5					↕				
Transfer 6					↕				
Transfer 7					↕				
Transfer 8					↕				

Default      Check      End      Cancel



## 1.5. Setting Global Labels

Global labels must be set before using this FB. This section explains global label settings.

(1) M\_F\_RWr Set remote input (RWr).

Item	Description
Class	Select "VAR_GLOBAL".
Label Name	Enter "M_F_RWr"
Data Type	Select "Word [Signed]".
Device	Enter the refresh device set for the refresh parameter with a "Z7" prefix.

(2) M\_F\_RWw Set remote output (RWw).

Item	Description
Class	Select "VAR_GLOBAL".
Label Name	Enter "M_F_RWw".
Data Type	Select "Word [Signed]".
Device	Enter the refresh device set for the refresh parameter with a "Z6" prefix.

	Class	Label Name	Data Type	Constant	Device	Comment
1	VAR_GLOBAL	M_F_RWr	Word[Signed]	...	w1000Z7	RWr refresh device
2	VAR_GLOBAL	M_F_RWw	Word[Signed]	...	w1100Z6	RWw refresh device
3				...		
4				...		
5				...		

## 1.6. Creating Interlock Program

Interlock programs must be created for the FBs. The following is an example of an interlock program.

Set an interlock program for cyclic transmission.

(Set a corresponding FB between MC and MCR instructions.)

### 1.6.1. Cyclic Transmission Program

Use link special relay (SB) and link special register (SW) to create an interlock for cyclic transmission program.

- Own station data link status (SB0049)
- Each station data link status (SW00B0 to SW00B7)

Example: Interlock example (station No.1)

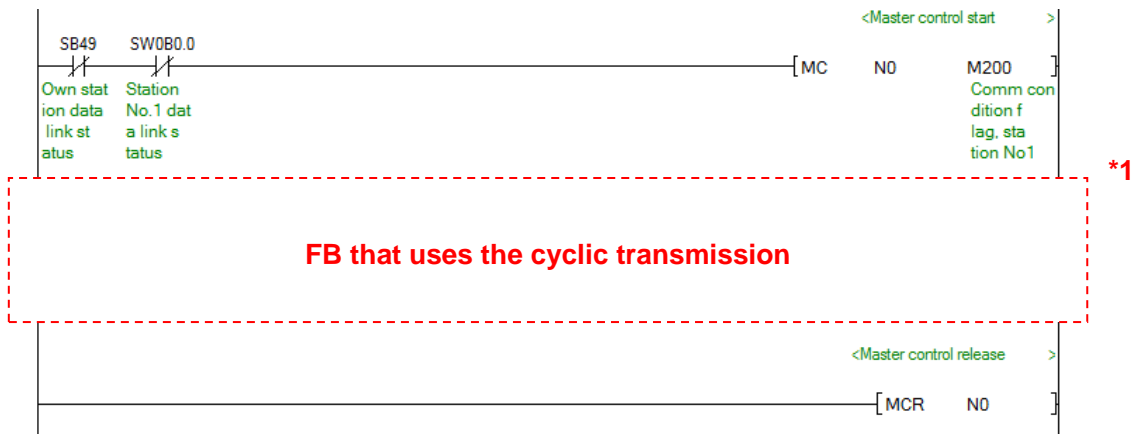

\*1 All the FBs in this manual use the cyclic transmission.

## 1.7. Relevant Manuals

CC-Link IE Field Network Waterproof/Dustproof Remote I/O Module User's Manual

MELSEC-Q CC-Link IE Field Network Master/Local Module User's Manual

MELSEC-L CC-Link IE Field Network Master/Local Module User's Manual

QCPU User's Manual (Hardware Design, Maintenance and Inspection)

MELSEC-L CPU Module User's Manual (Hardware Design, Maintenance and Inspection)

GX Works2 Version 1 Operating Manual (Common)

GX Works2 Version 1 Operating Manual (Simple Project, Function Block)

## 1.8. Note

Please make sure to read user's manuals for the corresponding products before using the products.

## 2. Details of the FB Library

### 2.1. M+NZ2GF12A16\_InitialProcessing (Initial processing)

#### FB Name

M+NZ2GF12A16\_InitialProcessing

#### Function Overview

Item	Description													
Function overview	Performs the initial processing after power-on.													
Symbol	<div style="display: flex; align-items: center; justify-content: space-between;"> <div style="width: 30%;"> <p>Execution command — B : FB_EN</p> <p>Module start XY address — W : i_Start_IO_No</p> <p>Station No. — W : i_Station_No</p> </div> <div style="width: 35%; border: 1px solid black; padding: 5px; text-align: center;"> <p>M+NZ2GF12A16_InitialProcessing</p> </div> <div style="width: 30%;"> <p>FB_ENO : B — Execution status</p> <p>FB_OK : B — Completed w without error</p> <p>FB_ERROR : B — Error flag</p> <p>ERROR_ID : W — Error code</p> </div> </div>													
Applicable hardware and software	CC-Link IE Field Network remote I/O module	NZ2GF12A4-16D, NZ2GF12A2-16T, NZ2GF12A42-16DT, NZ2GF12A4-16DE, NZ2GF12A2-16TE, NZ2GF12A42-16DTE												
	CC-Link IE Field Network module	CC-Link IE Field Network master/local module *1 *1 The first five digits of the serial number are "14102" or later.												
	CPU module	<table border="1" style="width: 100%; border-collapse: collapse;"> <thead> <tr> <th style="width: 50%;">Series</th> <th style="width: 50%;">Model</th> </tr> </thead> <tbody> <tr> <td>MELSEC-Q Series *1</td> <td>Universal model QCPU *2</td> </tr> <tr> <td>MELSEC-L Series</td> <td>LCPU *3</td> </tr> </tbody> </table> <p>*1 Not applicable to QCPU (A mode) *2 The first five digits of the serial number are "12012" or later. *3 The first five digits of the serial number are "13012" or later.</p>	Series	Model	MELSEC-Q Series *1	Universal model QCPU *2	MELSEC-L Series	LCPU *3						
Series	Model													
MELSEC-Q Series *1	Universal model QCPU *2													
MELSEC-L Series	LCPU *3													
Engineering software	GX Works2 *1 <table border="1" style="width: 100%; border-collapse: collapse;"> <thead> <tr> <th style="width: 50%;">Language</th> <th style="width: 50%;">Software version</th> </tr> </thead> <tbody> <tr> <td>Japanese version</td> <td>Version1.86Q or later</td> </tr> <tr> <td>English version</td> <td>Version1.24A or later</td> </tr> <tr> <td>Chinese (Simplified) version</td> <td>Version1.49B or later</td> </tr> <tr> <td>Chinese (Traditional) version</td> <td>Version1.49B or later</td> </tr> <tr> <td>Korean version</td> <td>Version1.49B or later</td> </tr> </tbody> </table> <p>*1 For software versions applicable to the modules used, refer to "Relevant manuals".</p>		Language	Software version	Japanese version	Version1.86Q or later	English version	Version1.24A or later	Chinese (Simplified) version	Version1.49B or later	Chinese (Traditional) version	Version1.49B or later	Korean version	Version1.49B or later
Language	Software version													
Japanese version	Version1.86Q or later													
English version	Version1.24A or later													
Chinese (Simplified) version	Version1.49B or later													
Chinese (Traditional) version	Version1.49B or later													
Korean version	Version1.49B or later													

Item	Description
Programming language	Ladder
Number of steps	449 steps (for MELSEC-Q series universal model CPU) * The number of steps of the FB in a program depends on the CPU model that is used and input and output definition.
Function description	<ol style="list-style-type: none"> <li>1) By turning ON FB_EN (Execution command), the initial processing after power-on is executed.</li> <li>2) FB operation is one-shot only, triggered by the FB_EN signal.</li> <li>3) After FB_EN (Execution command) is turned ON, the FB is completed in multiple scans.</li> <li>4) When the network configuration setting of the station number specified by i_Station_No (Station No.) is incorrect, FB_ERROR (Error flag) turns ON and processing is interrupted, and the error code 50 (decimal) is stored in ERROR_ID (Error code). Refer to the error code explanation section for details.</li> <li>5) When the setting value of i_Station_No (Station No.) is out of range, the FB_ERROR output turns ON and processing is interrupted, and the error code 60 (decimal) is stored in ERROR_ID (Error code). Refer to the error code explanation section for details.</li> </ol>
Compiling method	Macro type

Item	Description		
Restrictions and precautions	<ol style="list-style-type: none"> <li>1) The FB does not include error recovery processing. Program the error recovery processing separately in accordance with the required system operation.</li> <li>2) The FB cannot be used in an interrupt program.</li> <li>3) Please ensure that the FB_EN signal is capable of being turned OFF by the program. Do not use this FB in programs that are only executed once such as a subroutine, FOR-NEXT loop because it is impossible to turn OFF.</li> <li>4) This FB uses index registers Z6 to Z9. Please do not use these index registers in an interrupt program.</li> <li>5) A duplicated coil warning may occur during compile operation due to the RY signal being operated by index modification in the FB. However this is not a problem and the FB will operate without error.</li> <li>6) Every input must be provided with a value for proper FB operation.</li> <li>7) This FB uses cyclic transmission. Therefore, an interlock program for cyclic transmission is required. For the interlock program, refer to Section "1.6.1 Cyclic Transmission Program".</li> <li>8) Set the refresh parameters of the network parameter setting according to Section "1.4 Setting the CC-Link IE Field Network Master/Local Module".</li> <li>9) Set the global label setting according to Section "1.5 Setting Global Labels".</li> <li>10) Only one master/local module can be controlled by the CC-Link IE Field system FB. To control 2 or more master/local modules by the FB, refer to "Appendix 1. When Using the FB for 2 or More Master/Local Modules".</li> <li>11) If the processing of this FB is not completed, check if the station number of CC-Link IE Field matches the station number of the network.</li> </ol>		
FB operation type	Pulsed execution (multiple scan execution type)		
Application example	Refer to "Appendix 2. - FB Library Application Examples".		
Timing chart	<table border="0" style="width: 100%;"> <tr> <td style="width: 50%; vertical-align: top;"> <p>[When operation completes without error]</p> <p>m: Address allocated to the master module by setting the station number</p> </td> <td style="width: 50%; vertical-align: top;"> <p>[When an error occurs]</p> <p>m: Address allocated to the master module by setting the station number</p> </td> </tr> </table>	<p>[When operation completes without error]</p> <p>m: Address allocated to the master module by setting the station number</p>	<p>[When an error occurs]</p> <p>m: Address allocated to the master module by setting the station number</p>
<p>[When operation completes without error]</p> <p>m: Address allocated to the master module by setting the station number</p>	<p>[When an error occurs]</p> <p>m: Address allocated to the master module by setting the station number</p>		

Item	Description
Relevant manuals	CC-Link IE Field Network Waterproof/Dustproof Remote I/O Module User's Manual MELSEC-Q CC-Link IE Field Network Master/Local Module User's Manual MELSEC-L CC-Link IE Field Network Master/Local Module User's Manual QCPU User's Manual (Hardware Design, Maintenance and Inspection) MELSEC-L CPU Module User's Manual (Hardware Design, Maintenance and Inspection) GX Works2 Version 1 Operating Manual (Common) GX Works2 Version 1 Operating Manual (Simple Project, Function Block)

## Error codes

### ●Error code list

Error code	Description	Action
50 (Decimal)	The network configuration setting of the station number specified by i_Station_No is incorrect.	Review the following setting. <ul style="list-style-type: none"> <li>•Network configuration setting Refer to (2) in Section 1.4 Setting the CC-Link IE Field Network Master/Local Module</li> <li>•The value entered in i_Station_No</li> </ul>
60 (Decimal)	The specified station number is not valid. The station number is not within the range of 1 to 120.	Please try again after confirming the setting.

## Labels

### ●Input labels

Name (Comment)	Label name	Data type	Setting range	Description
Execution command	FB_EN	Bit	ON, OFF	ON: The FB is activated. OFF: The FB is not activated.
Module start XY address	i_Start_IO_No	Word	Depends on the I/O point range of the CPU. For details, refer to the CPU user's manual.	Specify the starting XY address (in hexadecimal) where the CC-Link IE Field Network master/local module is mounted. (For example, enter H10 for X10.)
Station No.	i_Station_No	Word	1 to 120	Specify the target station number.

### ●Output labels

Name (Comment)	Label name	Data type	Initial value	Description
Execution status	FB_ENO	Bit	OFF	ON: Execution command is ON. OFF: Execution command is OFF.
Completed without error	FB_OK	Bit	OFF	When ON, it indicates that the initial processing is completed.
Error flag	FB_ERROR	Bit	OFF	When ON, it indicates that an error has occurred.
Error code	ERROR_ID	Word	0	FB error code output.



## FB Version Upgrade History

Version	Date	Description
1.00A	2017/01	First edition

## Note

This chapter includes information related to this function block.

It does not include information on restrictions of use such as combination with modules or programmable controller CPUs.

Before using any Mitsubishi products, please read all the relevant manuals.

## 2.2. M+NZ2GF12A16\_SetOpeCondition (Operation condition setting)

### FB Name

M+NZ2GF12A16\_SetOpeCondition

### Function Overview

Item	Description													
Function overview	Performs the operation condition setting.													
Symbol	<div style="display: flex; align-items: center; justify-content: space-between;"> <div style="width: 30%;"> <p>Execution command — B : FB_EN</p> <p>Module start XY address — W : i_Start_IO_No</p> <p>Station No. — W : i_Station_No</p> </div> <div style="width: 35%; border: 1px solid black; padding: 5px; text-align: center;"> <p>M+NZ2GF12A16_SetOpeCondition</p> </div> <div style="width: 30%;"> <p>FB_ENO : B — Execution status</p> <p>FB_OK : B — Completed w without error</p> <p>FB_ERROR : B — Error flag</p> <p>ERROR_ID : W — Error code</p> </div> </div>													
Applicable hardware and software	CC-Link IE Field Network remote I/O module	NZ2GF12A4-16D, NZ2GF12A2-16T, NZ2GF12A42-16DT, NZ2GF12A4-16DE, NZ2GF12A2-16TE, NZ2GF12A42-16DTE												
	CC-Link IE Field Network module	CC-Link IE Field Network master/local module *1 *1 The first five digits of the serial number are "14102" or later.												
	CPU module	<table border="1" style="width: 100%; border-collapse: collapse;"> <thead> <tr> <th style="width: 50%;">Series</th> <th style="width: 50%;">Model</th> </tr> </thead> <tbody> <tr> <td>MELSEC-Q Series *1</td> <td>Universal model QCPU *2</td> </tr> <tr> <td>MELSEC-L Series</td> <td>LCPU *3</td> </tr> </tbody> </table> <p>*1 Not applicable to QCPU (A mode) *2 The first five digits of the serial number are "12012" or later. *3 The first five digits of the serial number are "13012" or later.</p>	Series	Model	MELSEC-Q Series *1	Universal model QCPU *2	MELSEC-L Series	LCPU *3						
Series	Model													
MELSEC-Q Series *1	Universal model QCPU *2													
MELSEC-L Series	LCPU *3													
Engineering software	GX Works2 *1 <table border="1" style="width: 100%; border-collapse: collapse;"> <thead> <tr> <th style="width: 50%;">Language</th> <th style="width: 50%;">Software version</th> </tr> </thead> <tbody> <tr> <td>Japanese version</td> <td>Version1.86Q or later</td> </tr> <tr> <td>English version</td> <td>Version1.24A or later</td> </tr> <tr> <td>Chinese (Simplified) version</td> <td>Version1.49B or later</td> </tr> <tr> <td>Chinese (Traditional) version</td> <td>Version1.49B or later</td> </tr> <tr> <td>Korean version</td> <td>Version1.49B or later</td> </tr> </tbody> </table> <p>*1 For software versions applicable to the modules used, refer to "Relevant Manuals".</p>		Language	Software version	Japanese version	Version1.86Q or later	English version	Version1.24A or later	Chinese (Simplified) version	Version1.49B or later	Chinese (Traditional) version	Version1.49B or later	Korean version	Version1.49B or later
Language	Software version													
Japanese version	Version1.86Q or later													
English version	Version1.24A or later													
Chinese (Simplified) version	Version1.49B or later													
Chinese (Traditional) version	Version1.49B or later													
Korean version	Version1.49B or later													

Item	Description
Programming language	Ladder
Number of steps	461 steps (for MELSEC-Q series universal model CPU) * The number of steps of the FB in a program depends on the CPU model that is used and input and output definition.
Function description	<ol style="list-style-type: none"> <li>1) By turning ON FB_EN (Execution command), the operation condition setting of the target module is performed.</li> <li>2) FB operation is one-shot only, triggered by the FB_EN signal.</li> <li>3) After FB_EN (Execution command) is turned ON, the FB is completed in multiple scans.</li> <li>4) When the network configuration setting of the station number specified by i_Station_No (Station No.) is incorrect, FB_ERROR (Error flag) turns ON and processing is interrupted, and the error code 50 (decimal) is stored in ERROR_ID (Error code). Refer to the error code explanation section for details.</li> <li>5) When the setting value of i_Station_No (Station No.) is out of range, the FB_ERROR output turns ON and processing is interrupted, and the error code 60 (decimal) is stored in ERROR_ID (Error code). Refer to the error code explanation section for details.</li> </ol>
Compiling method	Macro type

Item	Description		
Restrictions and precautions	<ol style="list-style-type: none"> <li>1) The FB does not include error recovery processing. Program the error recovery processing separately in accordance with the required system operation.</li> <li>2) The FB cannot be used in an interrupt program.</li> <li>3) Please ensure that the FB_EN signal is capable of being turned OFF by the program. Do not use this FB in programs that are only executed once such as a subroutine, FOR-NEXT loop because it is impossible to turn OFF.</li> <li>4) This FB uses index registers Z6 to Z9. Please do not use these index registers in an interrupt program.</li> <li>5) A duplicated coil warning may occur during compile operation due to the RY signal being operated by index modification in the FB. However this is not a problem and the FB will operate without error.</li> <li>6) Every input must be provided with a value for proper FB operation.</li> <li>7) This FB uses cyclic transmission. Therefore, an interlock program for cyclic transmission is required. For the interlock program, refer to Section "1.6.1 Cyclic Transmission Program".</li> <li>8) Set the refresh parameters of the network parameter setting according to Section "1.4 Setting the CC-Link IE Field Network Master/Local Module".</li> <li>9) Set the global label setting according to Section "1.5 Setting Global Labels".</li> <li>10) Only one master/local module can be controlled by the CC-Link IE Field system FB. To control 2 or more master/local modules by the FB, refer to "Appendix 1. When Using the FB for 2 or More Master/Local Modules".</li> <li>11) If the processing of this FB is not completed, check if the station number of CC-Link IE Field matches the station number of the network.</li> </ol>		
FB operation type	Pulsed execution (multiple scan execution type)		
Application example	Refer to "Appendix 2. - FB Library Application Examples".		
Timing chart	<table border="0" style="width: 100%; border-collapse: collapse;"> <tr> <td style="width: 50%; vertical-align: top; padding-right: 20px;"> <p>[When operation completes without error]</p> <p>FB_EN (Execution command)  FB_ENO (Execution status)  FB_OK (Completed without error)  RWwm+0 bit9 (Operation condition setting request flag)  RWrm+0 bit9 (Operation condition setting completion flag)  FB_ERROR (Error flag)  ERROR_ID (Error code) 0</p> <p>m: Address allocated to the master module by setting the station number</p> </td> <td style="width: 50%; vertical-align: top;"> <p>[When an error occurs]</p> <p>FB_EN (Execution command)  FB_ENO (Execution status)  FB_OK (Completed without error)  RWwm+0 bit9 (Operation condition setting request flag)  RWrm+0 bit9 (Operation condition setting completion flag)  FB_ERROR (Error flag)  ERROR_ID (Error code) Error code</p> <p>m: Address allocated to the master module by setting the station number</p> </td> </tr> </table>	<p>[When operation completes without error]</p> <p>FB_EN (Execution command)  FB_ENO (Execution status)  FB_OK (Completed without error)  RWwm+0 bit9 (Operation condition setting request flag)  RWrm+0 bit9 (Operation condition setting completion flag)  FB_ERROR (Error flag)  ERROR_ID (Error code) 0</p> <p>m: Address allocated to the master module by setting the station number</p>	<p>[When an error occurs]</p> <p>FB_EN (Execution command)  FB_ENO (Execution status)  FB_OK (Completed without error)  RWwm+0 bit9 (Operation condition setting request flag)  RWrm+0 bit9 (Operation condition setting completion flag)  FB_ERROR (Error flag)  ERROR_ID (Error code) Error code</p> <p>m: Address allocated to the master module by setting the station number</p>
<p>[When operation completes without error]</p> <p>FB_EN (Execution command)  FB_ENO (Execution status)  FB_OK (Completed without error)  RWwm+0 bit9 (Operation condition setting request flag)  RWrm+0 bit9 (Operation condition setting completion flag)  FB_ERROR (Error flag)  ERROR_ID (Error code) 0</p> <p>m: Address allocated to the master module by setting the station number</p>	<p>[When an error occurs]</p> <p>FB_EN (Execution command)  FB_ENO (Execution status)  FB_OK (Completed without error)  RWwm+0 bit9 (Operation condition setting request flag)  RWrm+0 bit9 (Operation condition setting completion flag)  FB_ERROR (Error flag)  ERROR_ID (Error code) Error code</p> <p>m: Address allocated to the master module by setting the station number</p>		

Item	Description
Relevant manuals	CC-Link IE Field Network Waterproof/Dustproof Remote I/O Module User's Manual MELSEC-Q CC-Link IE Field Network Master/Local Module User's Manual MELSEC-L CC-Link IE Field Network Master/Local Module User's Manual QCPU User's Manual (Hardware Design, Maintenance and Inspection) MELSEC-L CPU Module User's Manual (Hardware Design, Maintenance and Inspection) GX Works2 Version 1 Operating Manual (Common) GX Works2 Version 1 Operating Manual (Simple Project, Function Block)

## Error codes

### ●Error code list

Error code	Description	Action
50 (Decimal)	The network configuration setting of the station number specified by i_Station_No is incorrect.	Review the following setting. <ul style="list-style-type: none"> <li>•Network configuration setting Refer to (2) in Section 1.4 Setting the CC-Link IE Field Network Master/Local Module.</li> <li>•The value entered in i_Station_No</li> </ul>
60 (Decimal)	The specified station number is not valid. The station number is not within the range of 1 to 120.	Please try again after confirming the setting.

## Labels

### ●Input labels

Name (Comment)	Label name	Data type	Setting range	Description
Execution command	FB_EN	Bit	ON, OFF	ON: The FB is activated. OFF: The FB is not activated.
Module start XY address	i_Start_IO_No	Word	Depends on the I/O point range of the CPU. For details, refer to the CPU user's manual.	Specify the starting XY address (in hexadecimal) where the CC-Link IE Field Network master/local module is mounted. (For example, enter H10 for X10.)
Station No.	i_Station_No	Word	1 to 120	Specify the target station number.

### ●Output labels

Name (Comment)	Label name	Data type	Initial value	Description
Execution status	FB_ENO	Bit	OFF	ON: Execution command is ON. OFF: Execution command is OFF.
Completed without error	FB_OK	Bit	OFF	When ON, it indicates that the operation condition setting is completed.
Error flag	FB_ERROR	Bit	OFF	When ON, it indicates that an error has occurred.
Error code	ERROR_ID	Word	0	FB error code output.

## FB Version Upgrade History

Version	Date	Description
1.00A	2017/01	First edition

## Note

This chapter includes information related to this function block.

It does not include information on restrictions of use such as combination with modules or programmable controller CPUs.

Before using any Mitsubishi products, please read all the relevant manuals.

### 2.3. M+NZ2GF12A16\_ErrorOperation (Error operation)

#### FB Name

M+NZ2GF12A16\_ErrorOperation

#### Function Overview

Item	Description																																	
Function overview	Monitors the error status and warning status, and performs error clear.																																	
Symbol	<div style="border: 1px solid black; padding: 10px; width: fit-content; margin: auto;"> <p style="text-align: center; margin: 0;">M+NZ2GF12A16_ErrorOperation</p> <table style="width: 100%; border-collapse: collapse;"> <tr> <td style="width: 30%; border: none;">Execution command</td> <td style="width: 30%; border: none;">B : FB_EN</td> <td style="width: 30%; border: none;">FB_ENO : B</td> <td style="width: 10%; border: none;">Execution status</td> </tr> <tr> <td style="border: none;">Module start XY address</td> <td style="border: none;">W : i_Start_IO_No</td> <td style="border: none;">FB_OK : B</td> <td style="border: none;">Completed without error</td> </tr> <tr> <td style="border: none;">Station No.</td> <td style="border: none;">W : i_Station_No</td> <td style="border: none;">o_UNIT_ERROR : B</td> <td style="border: none;">Module error detection</td> </tr> <tr> <td style="border: none;">Error clear request</td> <td style="border: none;">B : i_ErrorReset</td> <td style="border: none;">o_UNIT_ERR_CODE : W</td> <td style="border: none;">Module error code</td> </tr> <tr> <td style="border: none;"></td> <td style="border: none;"></td> <td style="border: none;">o_UNIT_WARNING : B</td> <td style="border: none;">Module warning detection</td> </tr> <tr> <td style="border: none;"></td> <td style="border: none;"></td> <td style="border: none;">o_UNIT_WAR_CODE : W</td> <td style="border: none;">Module warning code</td> </tr> <tr> <td style="border: none;"></td> <td style="border: none;"></td> <td style="border: none;">FB_ERROR : B</td> <td style="border: none;">Error flag</td> </tr> <tr> <td style="border: none;"></td> <td style="border: none;"></td> <td style="border: none;">ERROR_ID : W</td> <td style="border: none;">Error code</td> </tr> </table> </div>		Execution command	B : FB_EN	FB_ENO : B	Execution status	Module start XY address	W : i_Start_IO_No	FB_OK : B	Completed without error	Station No.	W : i_Station_No	o_UNIT_ERROR : B	Module error detection	Error clear request	B : i_ErrorReset	o_UNIT_ERR_CODE : W	Module error code			o_UNIT_WARNING : B	Module warning detection			o_UNIT_WAR_CODE : W	Module warning code			FB_ERROR : B	Error flag			ERROR_ID : W	Error code
Execution command	B : FB_EN	FB_ENO : B	Execution status																															
Module start XY address	W : i_Start_IO_No	FB_OK : B	Completed without error																															
Station No.	W : i_Station_No	o_UNIT_ERROR : B	Module error detection																															
Error clear request	B : i_ErrorReset	o_UNIT_ERR_CODE : W	Module error code																															
		o_UNIT_WARNING : B	Module warning detection																															
		o_UNIT_WAR_CODE : W	Module warning code																															
		FB_ERROR : B	Error flag																															
		ERROR_ID : W	Error code																															
Applicable hardware and software	CC-Link IE Field Network remote I/O module	NZ2GF12A4-16D, NZ2GF12A2-16T, NZ2GF12A42-16DT, NZ2GF12A4-16DE, NZ2GF12A2-16TE, NZ2GF12A42-16DTE																																
	CC-Link IE Field Network module	CC-Link IE Field Network master/local module *1 *1 The first five digits of the serial number are "14102" or later.																																
	CPU module	<table border="1" style="width: 100%; border-collapse: collapse; margin-bottom: 10px;"> <thead> <tr> <th style="width: 50%;">Series</th> <th style="width: 50%;">Model</th> </tr> </thead> <tbody> <tr> <td>MELSEC-Q Series *1</td> <td>Universal model QCPU *2</td> </tr> <tr> <td>MELSEC-L Series</td> <td>LCPU *3</td> </tr> </tbody> </table> <p>*1 Not applicable to QCPU (A mode) *2 The first five digits of the serial number are "12012" or later. *3 The first five digits of the serial number are "13012" or later.</p>	Series	Model	MELSEC-Q Series *1	Universal model QCPU *2	MELSEC-L Series	LCPU *3																										
Series	Model																																	
MELSEC-Q Series *1	Universal model QCPU *2																																	
MELSEC-L Series	LCPU *3																																	



Item	Description													
	Engineering software	GX Works2 *1 <table border="1" data-bbox="691 248 1505 544"> <thead> <tr> <th data-bbox="691 248 1094 297">Language</th> <th data-bbox="1094 248 1505 297">Software version</th> </tr> </thead> <tbody> <tr> <td data-bbox="691 297 1094 347">Japanese version</td> <td data-bbox="1094 297 1505 347">Version1.86Q or later</td> </tr> <tr> <td data-bbox="691 347 1094 396">English version</td> <td data-bbox="1094 347 1505 396">Version1.24A or later</td> </tr> <tr> <td data-bbox="691 396 1094 445">Chinese (Simplified) version</td> <td data-bbox="1094 396 1505 445">Version1.49B or later</td> </tr> <tr> <td data-bbox="691 445 1094 495">Chinese (Traditional) version</td> <td data-bbox="1094 445 1505 495">Version1.49B or later</td> </tr> <tr> <td data-bbox="691 495 1094 544">Korean version</td> <td data-bbox="1094 495 1505 544">Version1.49B or later</td> </tr> </tbody> </table> <p data-bbox="691 555 1505 640">*1 For software versions applicable to the modules used, refer to "Relevant Manuals".</p>	Language	Software version	Japanese version	Version1.86Q or later	English version	Version1.24A or later	Chinese (Simplified) version	Version1.49B or later	Chinese (Traditional) version	Version1.49B or later	Korean version	Version1.49B or later
Language	Software version													
Japanese version	Version1.86Q or later													
English version	Version1.24A or later													
Chinese (Simplified) version	Version1.49B or later													
Chinese (Traditional) version	Version1.49B or later													
Korean version	Version1.49B or later													
Programming language	Ladder													
Number of steps	575 steps (for MELSEC-Q series universal model CPU) * The number of steps of the FB in a program depends on the CPU model that is used and input and output definition.													
Function description	<ol style="list-style-type: none"> <li data-bbox="375 891 1505 972">1) By turning ON FB_EN (Execution command), the error status and warning status in the target module is monitored.</li> <li data-bbox="375 987 1505 1068">2) When an error occurs, o_UNIT_ERROR (Module error detection) is turned ON and the error code is stored in o_UNIT_ERR_CODE (Module error code).</li> <li data-bbox="375 1084 1505 1164">3) When a warning occurs, o_UNIT_WARNING (Module warning detection) is turned ON and the warning code is stored in o_UNIT_WAR_CODE (Module warning code).</li> <li data-bbox="375 1180 1505 1261">4) When an alarm occurs, the alarm code is stored in o_UNIT_WAR_CODE (Module warning code).</li> <li data-bbox="375 1276 1505 1447">5) After FB_EN (Execution command) is turned ON, error clear is performed when i_ErrorReset (Error clear request) is turned ON during error occurrence. A warning is cleared automatically five seconds after the cause of the minor error in the module is removed.</li> <li data-bbox="375 1462 1505 1655">6) When the network configuration setting of the station number specified by i_Station_No (Station No.) is incorrect, FB_ERROR (Error flag) turns ON and processing is interrupted, and the error code 50 (decimal) is stored in ERROR_ID (Error code). Refer to the error code explanation section for details.</li> <li data-bbox="375 1671 1505 1863">7) When the setting value of i_Station_No (Station No.) is out of range, the FB_ERROR output turns ON and processing is interrupted, and the error code 60 (decimal) is stored in ERROR_ID (Error code). Refer to the error code explanation section for details.</li> </ol>													
Compiling method	Macro type													

Item	Description
Restrictions and precautions	<ol style="list-style-type: none"> <li>1) The FB does not include error recovery processing. Program the error recovery processing separately in accordance with the required system operation.</li> <li>2) The FB cannot be used in an interrupt program.</li> <li>3) Please ensure that the FB_EN signal is capable of being turned OFF by the program. Do not use this FB in programs that are only executed once such as a subroutine, FOR-NEXT loop because it is impossible to turn OFF.</li> <li>4) This FB uses index registers Z6 to Z9. Please do not use these index registers in an interrupt program.</li> <li>5) A duplicated coil warning may occur during compile operation due to the RY signal being operated by index modification in the FB. However this is not a problem and the FB will operate without error.</li> <li>6) Every input must be provided with a value for proper FB operation.</li> <li>7) This FB uses cyclic transmission. Therefore, an interlock program for cyclic transmission is required. For the interlock program, refer to Section "1.6.1 Cyclic Transmission Program".</li> <li>8) Set the refresh parameters of the network parameter setting according to Section "1.4 Setting the CC-Link IE Field Network Master/Local Module".</li> <li>9) Set the global label setting according to Section "1.5 Setting Global Labels".</li> <li>10) Only one master/local module can be controlled by the CC-Link IE Field system FB. To control 2 or more master/local modules by the FB, refer to "Appendix 1. When Using the FB for 2 or More Master/Local Modules".</li> <li>11) If the processing of this FB is not completed, check if the station number of CC-Link IE Field matches the station number of the network. Also, confirm that the causes of the error, warning and alarm have been removed.</li> </ol>
FB operation type	Real-time execution
Application example	Refer to "Appendix 2. - FB Library Application Examples".

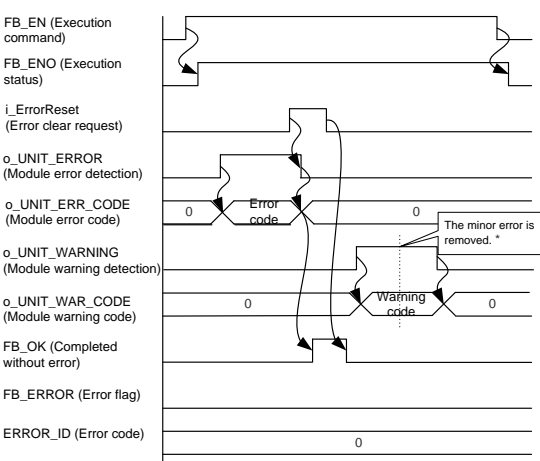
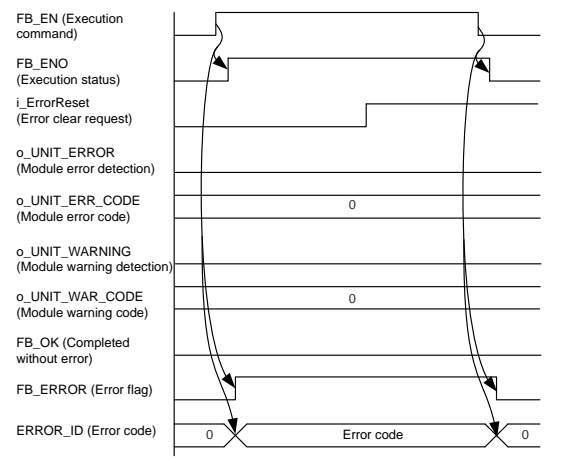
Item	Description	
Timing chart	<p>[When operation completes without error]</p>  <p>* Five seconds after the cause of the minor error is eliminated, "module warning detection" and "module warning code" are automatically cleared.</p>	<p>[When an error occurs]</p> 
Relevant manuals	<p>CC-Link IE Field Network Waterproof/Dustproof Remote I/O Module User's Manual  MELSEC-Q CC-Link IE Field Network Master/Local Module User's Manual  MELSEC-L CC-Link IE Field Network Master/Local Module User's Manual  QCPU User's Manual (Hardware Design, Maintenance and Inspection)  MELSEC-L CPU Module User's Manual (Hardware Design, Maintenance and Inspection)  GX Works2 Version 1 Operating Manual (Common)  GX Works2 Version 1 Operating Manual (Simple Project, Function Block)</p>	

## Error codes

### ● Error code list

Error code	Description	Action
50 (Decimal)	The network configuration setting of the station number specified by i_Station_No is incorrect.	Review the following setting. <ul style="list-style-type: none"> <li>•Network configuration setting Refer to (2) in Section 1.4 Setting the CC-Link IE Field Network Master/Local Module.</li> <li>•The value entered in i_Station_No</li> </ul>
60 (Decimal)	The specified station number is not valid. The station number is not within the range of 1 to 120.	Please try again after confirming the setting.

## Labels

### ●Input labels

Name (Comment)	Label name	Data type	Setting range	Description
Execution command	FB_EN	Bit	ON, OFF	ON: The FB is activated. OFF: The FB is not activated.
Module start XY address	i_Start_IO_No	Word	Depends on the I/O point range of the CPU. For details, refer to the CPU user's manual.	Specify the starting XY address (in hexadecimal) where the CC-Link IE Field Network master/local module is mounted. (For example, enter H10 for X10.)
Station No.	i_Station_No	Word	1 to 120	Specify the target station number.
Error clear request	i_ErrorReset	Bit	ON, OFF	Turn ON when performing error clear. Turn OFF the request when FB_OK (Completed without error) is turned ON.

### ●Output labels

Name (Comment)	Label name	Data type	Initial value	Description
Execution status	FB_ENO	Bit	OFF	ON: Execution command is ON. OFF: Execution command is OFF.
Completed without error	FB_OK	Bit	OFF	When ON, it indicates error clear is completed.
Module error detection	o_UNIT_ERROR	Bit	OFF	When ON, it indicates an error has occurred.
Module error code	o_UNIT_ERR_CODE	Word	0	Return the error code for an error that occurred in the module.
Module warning detection	o_UNIT_WARNING	Bit	OFF	When ON, it indicates a warning has occurred.
Module warning code	o_UNIT_WAR_CODE	Word	0	Return the warning code for a warning that occurred in the module.

Name (Comment)	Label name	Data type	Initial value	Description
Error flag	FB_ERROR	Bit	OFF	When ON, it indicates that an error has occurred.
Error code	ERROR_ID	Word	0	FB error code output.

### FB Version Upgrade History

Version	Date	Description
1.00A	2017/01	First edition

### Note

This chapter includes information related to this function block.

It does not include information on restrictions of use such as combination with modules or programmable controller CPUs.

Before using any Mitsubishi products, please read all the relevant manuals.

## Appendix 1. When Using the FB for 2 or More Master/Local Modules

To use 2 or more CC-Link IE field master/local modules and to use an FB for the second and subsequent CC-Link IE field master/local modules, it is necessary to create an FB for the second and subsequent modules from the MELSOFT Library CC-Link IE field master/local module FB using the following procedure.

Four steps are required to create the FB for the second and subsequent modules.

- (1) Enter network parameters
- (2) Set global labels
- (3) Copy MELSOFT Library to create the FB for the second module
- (4) Replace devices to create the FB for the second module

Appendix 1.1. Entering Network Parameters

(1) Enter the network parameters for the second module.

Item	Description
Network Type	Select CC IE Field (Master Station).
Start I/O No.	Set the start I/O number of the master/local module in increments of 16 points. Set "0020".
Network No.	Set the network number of the master/local module. Set "2".

\*Select this checkbox.



Set network configuration setting in CC IE Field configuration window

	Module 1	Module 2
Network Type	CC IE Field (Master Station) ▼	CC IE Field (Master Station) ▼
Start I/O No.	0000	0020
Network No.	1	2
Total Stations	1	0
Group No.		
Station No.	0	0
Mode	Online (Normal Mode) ▼	Online (Normal Mode) ▼
	<a href="#">CC IE Field Configuration Setting</a>	<a href="#">CC IE Field Configuration Setting</a>
	<a href="#">Network Operation Settings</a>	<a href="#">Network Operation Settings</a>
	<a href="#">Refresh Parameters</a>	<a href="#">Refresh Parameters</a>
	<a href="#">Interrupt Settings</a>	<a href="#">Interrupt Settings</a>
	Specify Station No. by Parameter ▼	Specify Station No. by Parameter ▼

(2) Set the CC IE Field configuration setting for the second module.

Item	Description
Station No.	Set the station number of the remote device station connected to the master station. Set "1".
Station Type	Set the station type of the remote device station connected to the master station. Set "Remote Device Station".
RX/Ry Setting	Set assignment for RX/Ry for the remote device station connected to the master station. (a) Start Set "0000". (b) End Set "000F".
RWw/RWr Setting	Set assignment for RWw/RWr for the remote device station connected to the master station. (a) Start Set "0000". (b) End Set "000B".

[When using NZ2GF12A4-16D]

	No.	Model Name	STA#	Station Type	RX/Ry Setting			RWw/RWr Setting			Refresh Device
					Points	Start	End	Points	Start	End	RX
	0	Host Station	0	Master Station							
	1	NZ2GF12A4-16D	1	Remote Device Station	16	0000	000F	12	0000	000B	M1040 (16 points)

\*Set the module to be used according to the environment.



(3) Enter the refresh parameters for the second module.

Item	Description	Setting value
Transfer SB	Select the link refresh range of SB device.	<ul style="list-style-type: none"> <li>•"Link Side Points" : 512</li> <li>•"Link Side Start" : 0000</li> <li>•"PLC Side Dev. Name" : SB</li> <li>•"PLC Side Start" : 0200</li> </ul>
Transfer SW	Select the link refresh range of SW device.	<ul style="list-style-type: none"> <li>•"Link Side Points" : 512</li> <li>•"Link Side Start" : 0000</li> <li>•"PLC Side Dev. Name" : SW</li> <li>•"PLC Side Start" : 0200</li> </ul>
Transfer 1	Select the link refresh range of RX device.	<ul style="list-style-type: none"> <li>•"Link Side Dev. Name" : RX</li> <li>•"Link Side Points" : 16</li> <li>•"Link Side Start" : 0000</li> <li>•"PLC Side Dev. Name" : M</li> <li>•"PLC Side Start" : 1040</li> </ul>
Transfer 2	Select the link refresh range of RY device.	<ul style="list-style-type: none"> <li>•"Link Side Dev. Name" : RY</li> <li>•"Link Side Points" : 16</li> <li>•"Link Side Start" : 0000</li> <li>•"PLC Side Dev. Name" : M</li> <li>•"PLC Side Start" : 2064</li> </ul>
Transfer 3	Select the link refresh range of RWr device.	<ul style="list-style-type: none"> <li>•"Link Side Dev. Name" : RWr</li> <li>•"Link Side Points" : 12</li> <li>•"Link Side Start" : 0000</li> <li>•"PLC Side Dev. Name" : W</li> <li>•"PLC Side Start" : 1010</li> </ul>
Transfer 4	Select the link refresh range of RWw device.	<ul style="list-style-type: none"> <li>•"Link Side Dev. Name" : RWw</li> <li>•"Link Side Points" : 12</li> <li>•"Link Side Start" : 0000</li> <li>•"PLC Side Dev. Name" : W</li> <li>•"PLC Side Start" : 1110</li> </ul>

\* Change the Points of Link Side and Dev. Name and Start of PLC Side according to the system.

Assignment Method

- Points/Start
- Start/End

	Link Side					PLC Side			
	Dev. Name	Points	Start	End		Dev. Name	Points	Start	End
Transfer SB	SB	512	0000	01FF	↕	SB	512	0200	03FF
Transfer SW	SW	512	0000	01FF	↕	SW	512	0200	03FF
Transfer 1	RX	16	0000	000F	↕	M	16	1040	1055
Transfer 2	RY	16	0000	000F	↕	M	16	2064	2079
Transfer 3	RWr	12	0000	000B	↕	W	12	001010	00101B
Transfer 4	RWw	12	0000	000B	↕	W	12	001110	00111B
Transfer 5					↕				
Transfer 6					↕				
Transfer 7					↕				
Transfer 8					↕				

## Appendix 1.2. Entering Global Labels

Enter the global labels for the second module.

Specify label names for the second module. The names must be different from the label names for the first module.

The following explains how to set the global label for the second module.

### (1) M\_F\_RWr2 Set remote register (RWr).

Item	Description
Class	Select "VAR_GLOBAL".
Label Name	Enter "M_F_RWr2".
Data Type	Select "Word [Signed]".
Device	Enter the refresh device set for the refresh parameter with a "Z7" prefix.

### (2) M\_F\_RWw2 Set remote register (RWw).

Item	Description
Class	Select "VAR_GLOBAL".
Label Name	Enter "M_F_RWw2".
Data Type	Select "Word [Signed]".
Device	Enter the refresh device set for the refresh parameter with a "Z6" prefix.

	Class	Label Name	Data Type	Constant	Device	Comment
1	VAR_GLOBAL	M_F_RWr	Word[Signed]	...	W1 000Z7	RWr refresh device
2	VAR_GLOBAL	M_F_RWw	Word[Signed]	...	W1 100Z6	RWw refresh device
3	VAR_GLOBAL	M_F_RWr2	Word[Signed]	...	W1 01 0Z7	RWr refresh device
4	VAR_GLOBAL	M_F_RWw2	Word[Signed]	...	W1 11 0Z6	RWw refresh device
5				...		
6				...		

### Appendix 1.3. Copying MELSOFT Library to Create an FB for the Second Module

(1) Select an FB necessary for the second module from the Project tab of the Navigation window. Execute the Copy command.

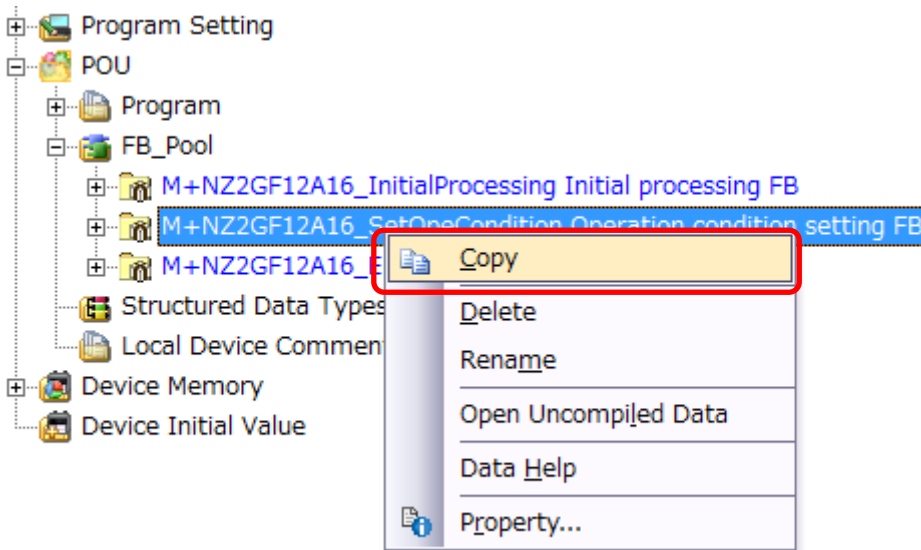

(2) Paste the copied FB to "FB\_Pool" on the Project tab of the Navigation window.

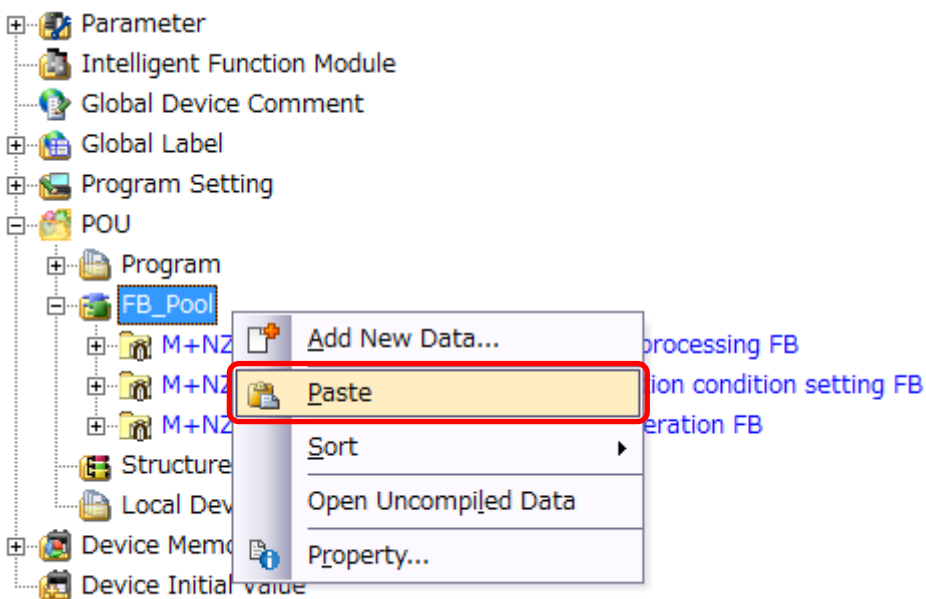

(3) After selecting the paste command, a window appears to enter an FB name. Enter an FB name after paste.

(Example: NZ2GF12A16\_SetOpeCondition2)

[Note] The character string "+" of M+... cannot be entered.

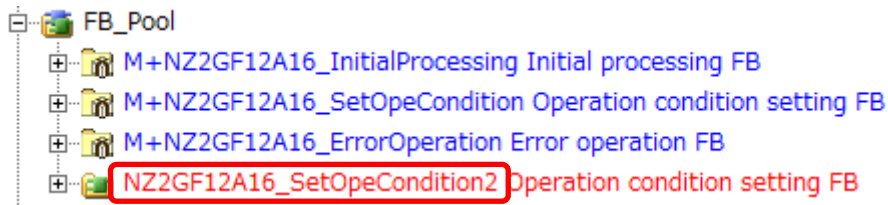
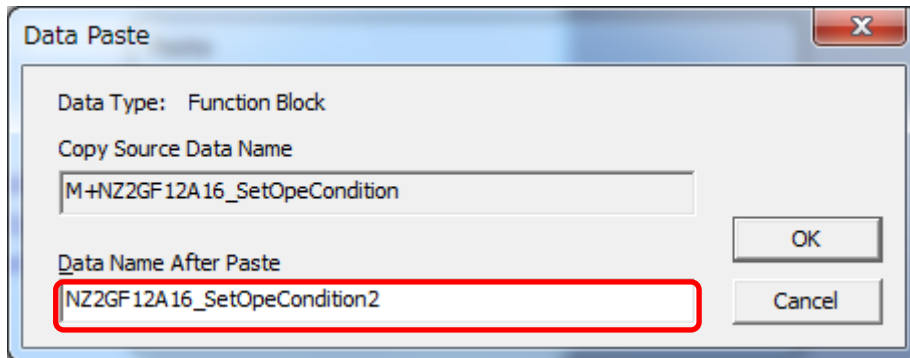

Appendix 1.4. Replacing Devices to Create the FB for the Second Module

(1) Open "Program" of the added FB.

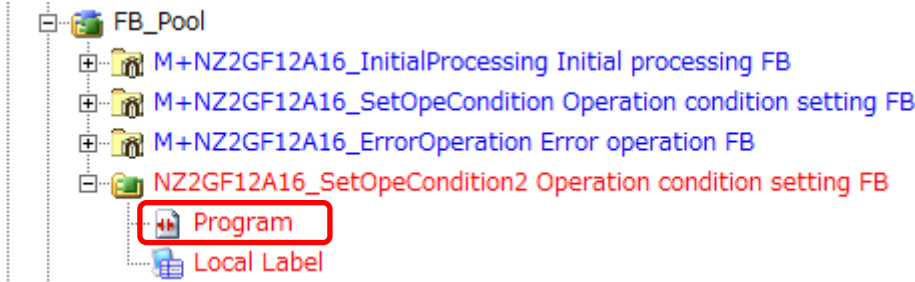

(2) Select "Find/Replace" menu and then select "Replace Device". "Find/Replace" window appears.

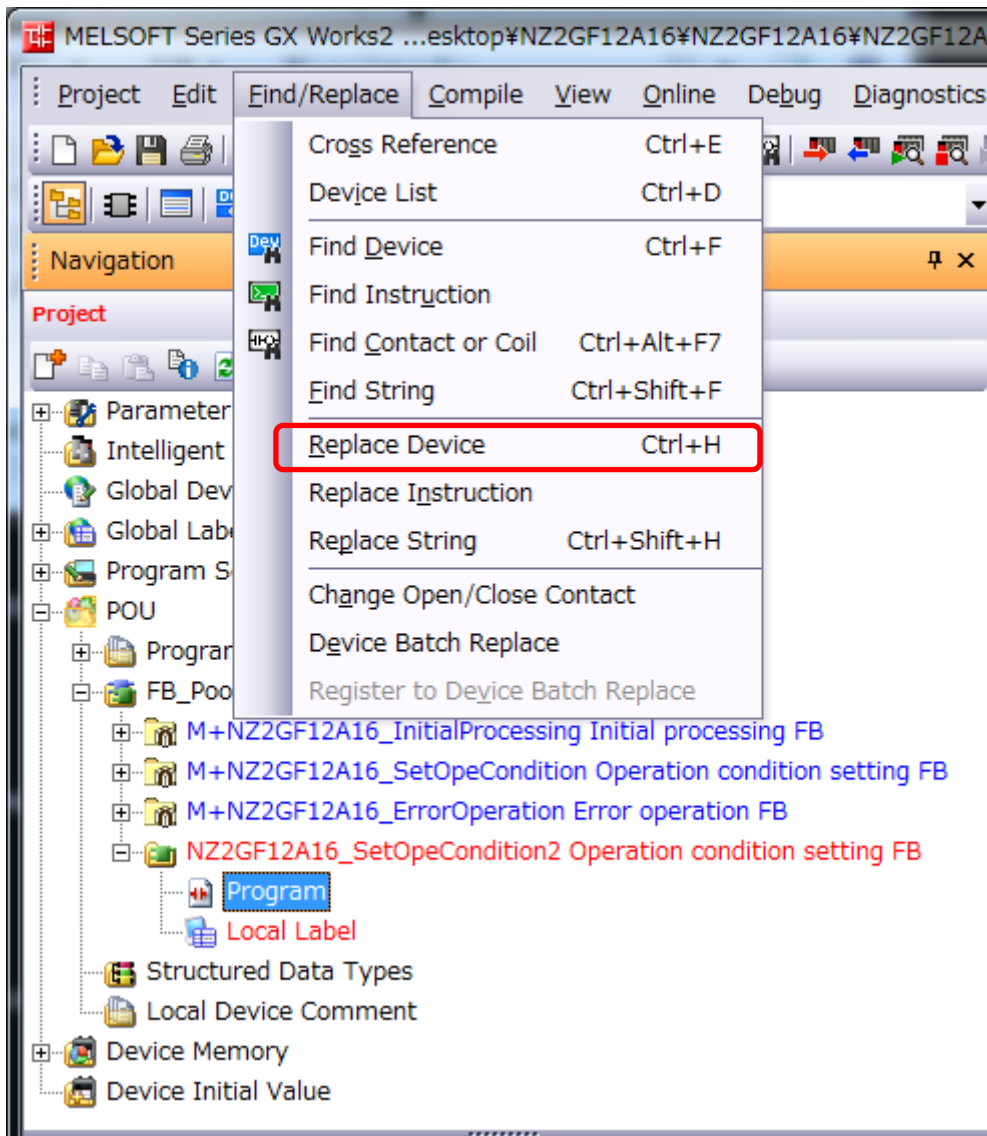

- (3) Select "Current Window" from Find In, "M\_F\_RWr" from Find Device, and "M\_F\_RWr2" from Replace Device. Then replace all devices. In the same way, replace "M\_F\_RWw" all at once.

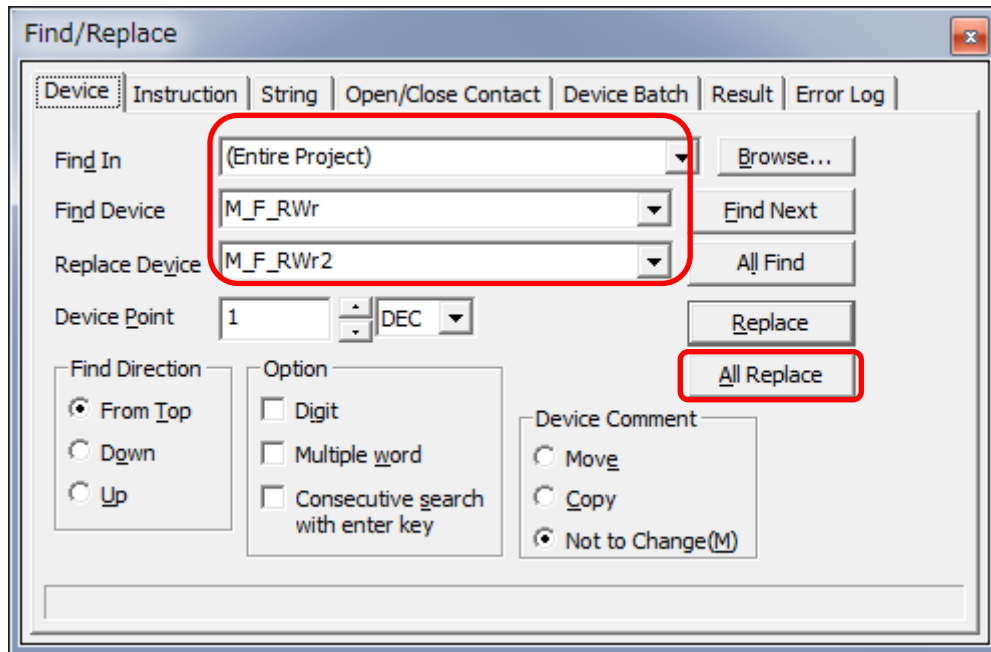

By performing the steps above, the CC-Link IE field master/local FB can be used for the second module.

[Point]

- (1) To use multiple FBs for the second CC-Link IE field master/local module, repeat "Appendix 1. When Using the FB for 2 or More Master/Local Modules".
- (2) To use an FB for third or subsequent CC-Link IE field master/local modules, make sure that the "Global label name", "Data Name After Paste" that is set when pasting FB data and "Replace Device" that is set when replacing devices are not duplicated for the first and second modules.

[Note]

If MELSOFT Library is upgraded, MELSOFT Library FBs can be upgraded by importing them again. However, the FBs that were created by following these procedures for the second and subsequent modules are not upgraded even if the FBs are imported again.

Therefore, to upgrade FBs that were created by following these procedures, after upgrading MELSOFT Library, follow these procedures again.

## Appendix 2. FB Library Application Examples

The application examples of the CC-Link IE Field Network remote I/O module FB are as follows.

### 1) System configuration

#### (1) Q series system configuration

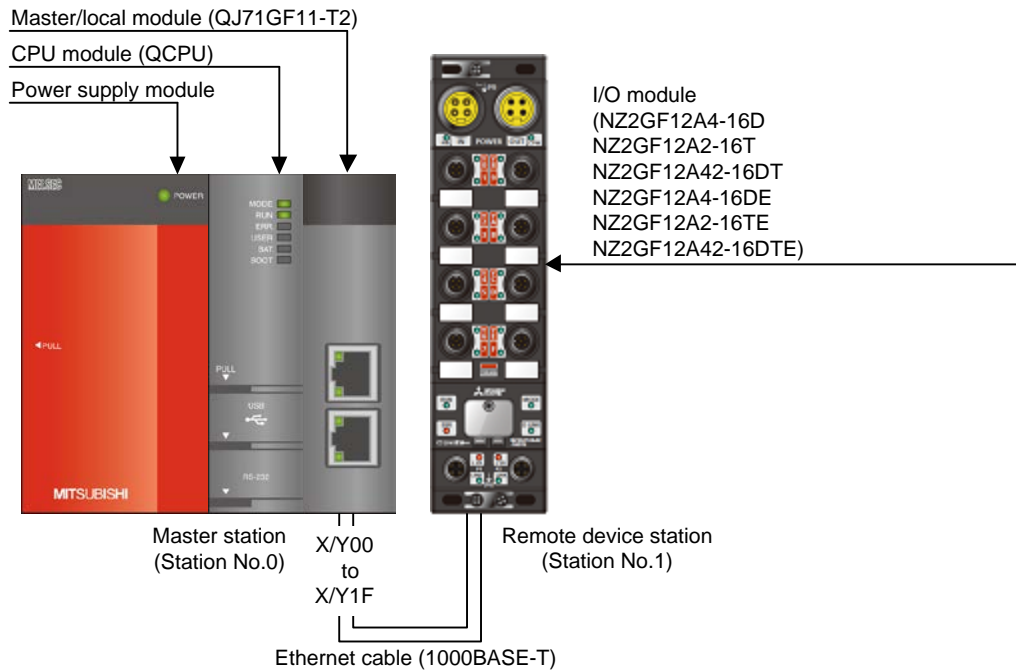

#### (2) L series system configuration

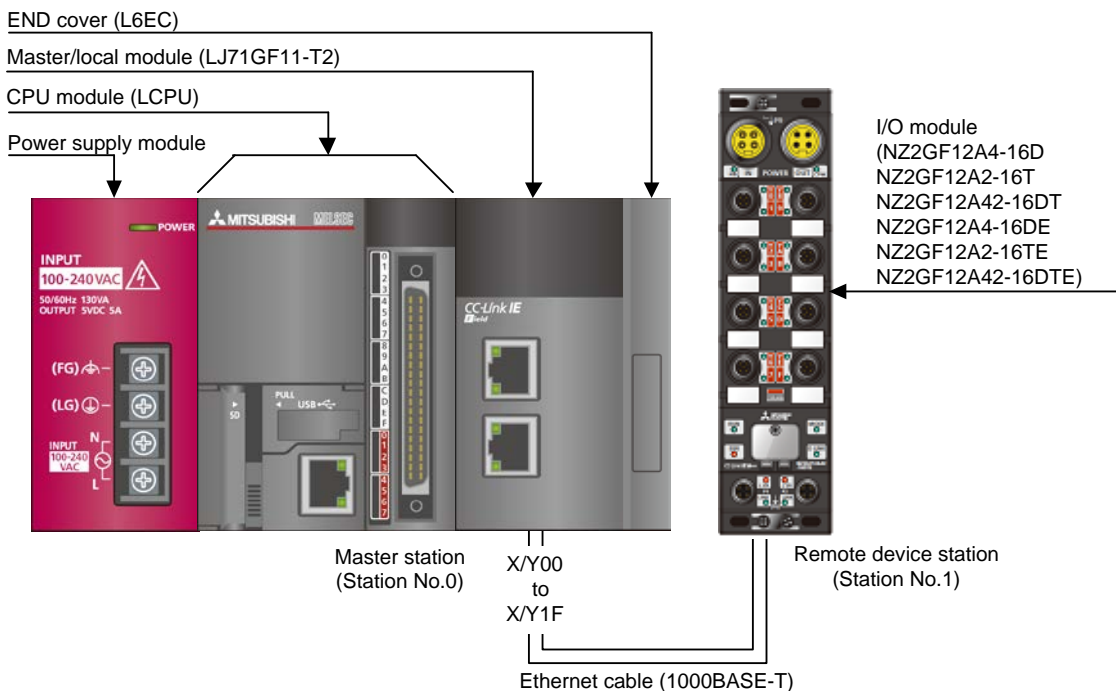



## Reminder

- Every input must be provided with a value for proper FB operation.  
If not set, the values will be unspecified.
- Abbreviations may be used in the label comments due to the limitation on the number of the characters to display in GX Works2.

Interlock program

\* The following is an example of an interlock program.

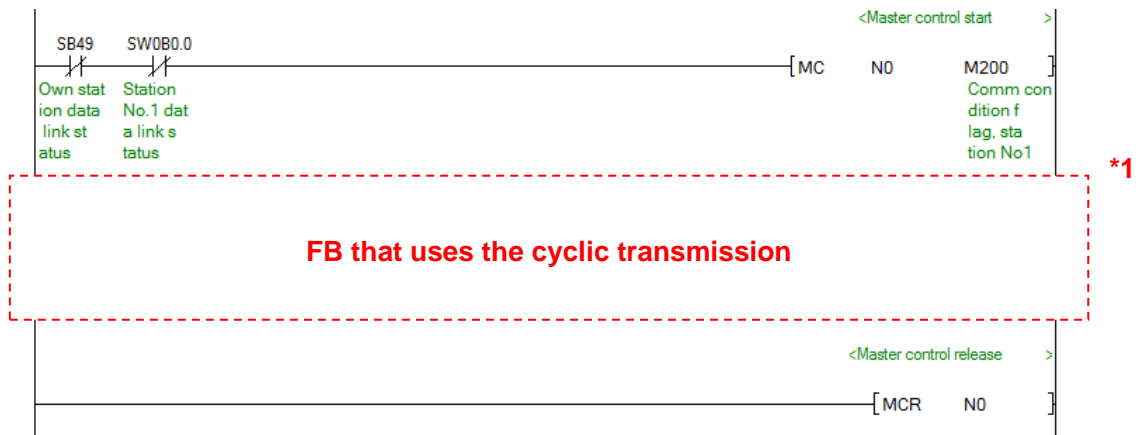

\*1 All the FBs in this manual use the cyclic transmission.

## 2) List of devices

### a) External input (commands)

Device	FB name	Application (ON details)
M0	M+NZ2GF12A16_InitialProcessing	Initial processing request
M10	M+NZ2GF12A16_SetOpeCondition	Operation condition setting request
M20	M+NZ2GF12A16_ErrorOperation	Error operation request
M21		Error clear request

### b) External output (checks)

Device	FB name	Application (ON details)
M1	M+NZ2GF12A16_InitialProcessing	Initial processing FB ready
M2		Initial processing FB complete
F0		Initial processing FB error
D0		Initial processing FB error code
M11	M+NZ2GF12A16_SetOpeCondition	Operation condition setting FB ready
M12		Operation condition setting FB complete
F5		Operation condition setting FB error
D10		Operation condition setting FB error code
M22	M+NZ2GF12A16_ErrorOperation	Error operation FB ready
M23		Error operation FB complete
M24		Module error detection
D20		Module error code
M25		Module warning detection
D21		Module warning code
F10		Error operation FB error
D22		Error operation FB error code

## 3) Global label setting

### a) Common setting

Class	Label name	Data type	Device
VAR_GLOBAL	M_F_RWr	Word [Signed]	W1000Z7
VAR_GLOBAL	M_F_RWw	Word [Signed]	W1100Z6

## 4) Programs

### M+NZ2GF12A16\_InitialProcessing (Initial processing)

The example below shows a program with the following conditions.

Label name	Setting value	Description
i_Start_IO_No	H0	Set the starting XY address where the CC-Link IE Field Network master/local module is mounted to 0H.
i_Station_No	K1	Set the target station number to 1.

By turning ON M0, the initial processing is performed.

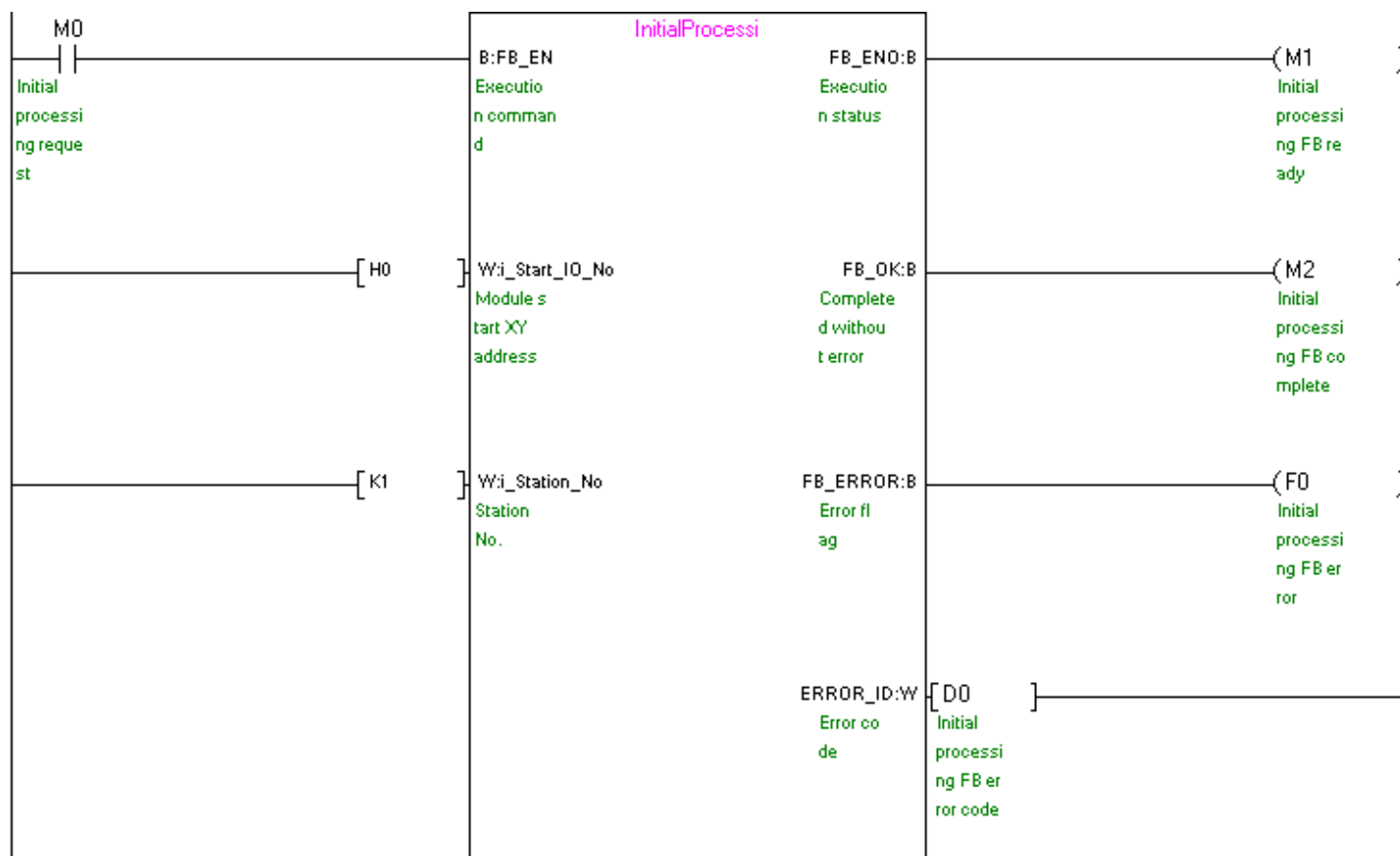

M+NZ2GF12A16\_SetOpeCondition (Operation condition setting)

The example below shows a program with the following conditions.

Label name	Setting value	Description
i_Start_IO_No	H0	Set the starting XY address where the CC-Link IE Field Network master/local module is mounted to 0H.
i_Station_No	K1	Set the target station number to 1.

By turning ON M10, the operation condition of the module is set.

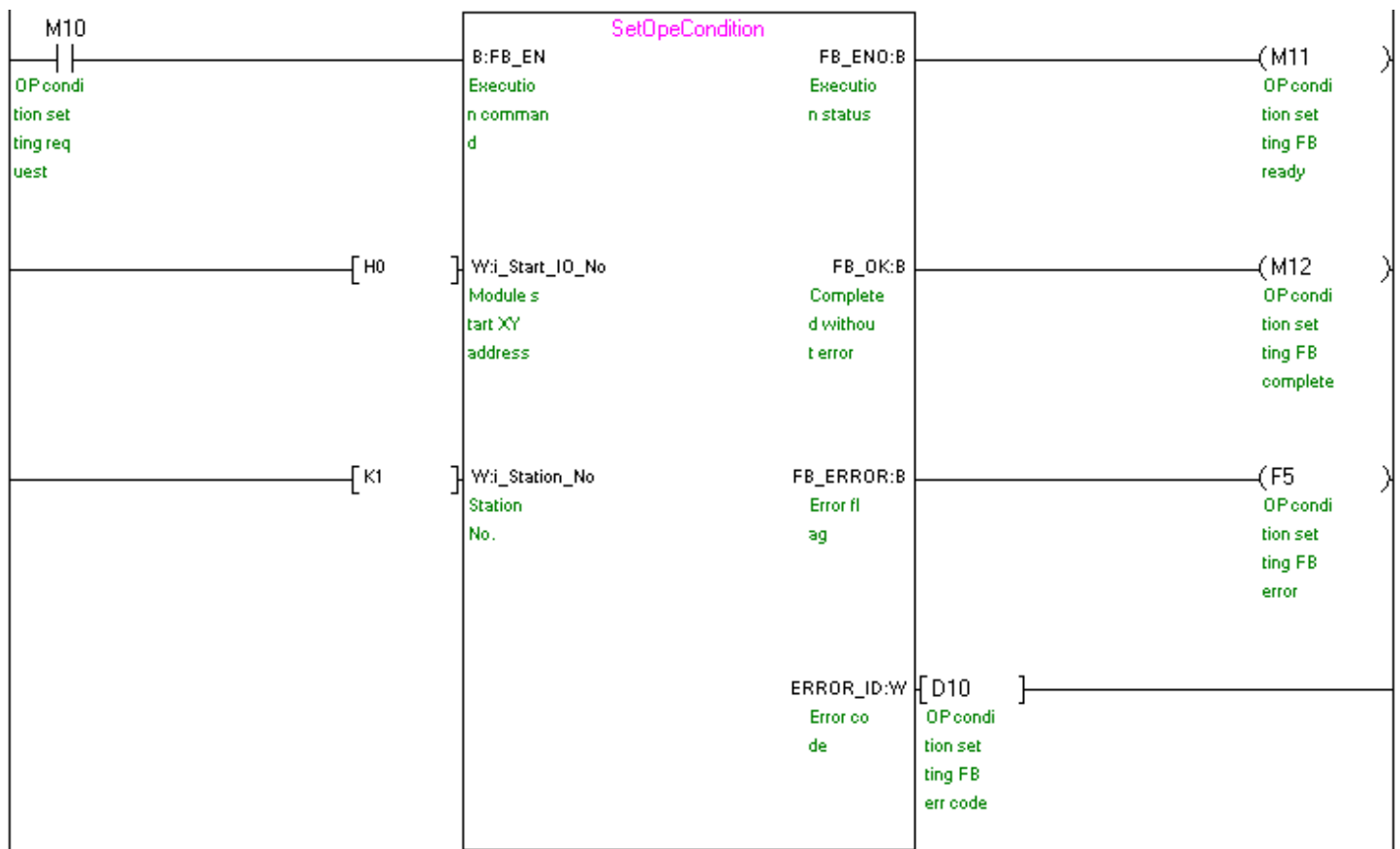

M+NZ2GF12A16\_ErrorOperation (Error operation)

The example below shows a program with the following conditions.

Label name	Setting value	Description
i_Start_IO_No	H0	Set the starting XY address where the CC-Link IE Field Network master/local module is mounted to 0H.
i_Station_No	K1	Set the target station number to 1.
i_ErrorReset	ON/OFF	Turn ON when performing error clear.

By turning ON M20, error and warning occurrences are monitored.  
After turning ON M20, by turning ON M21, error clear is performed.

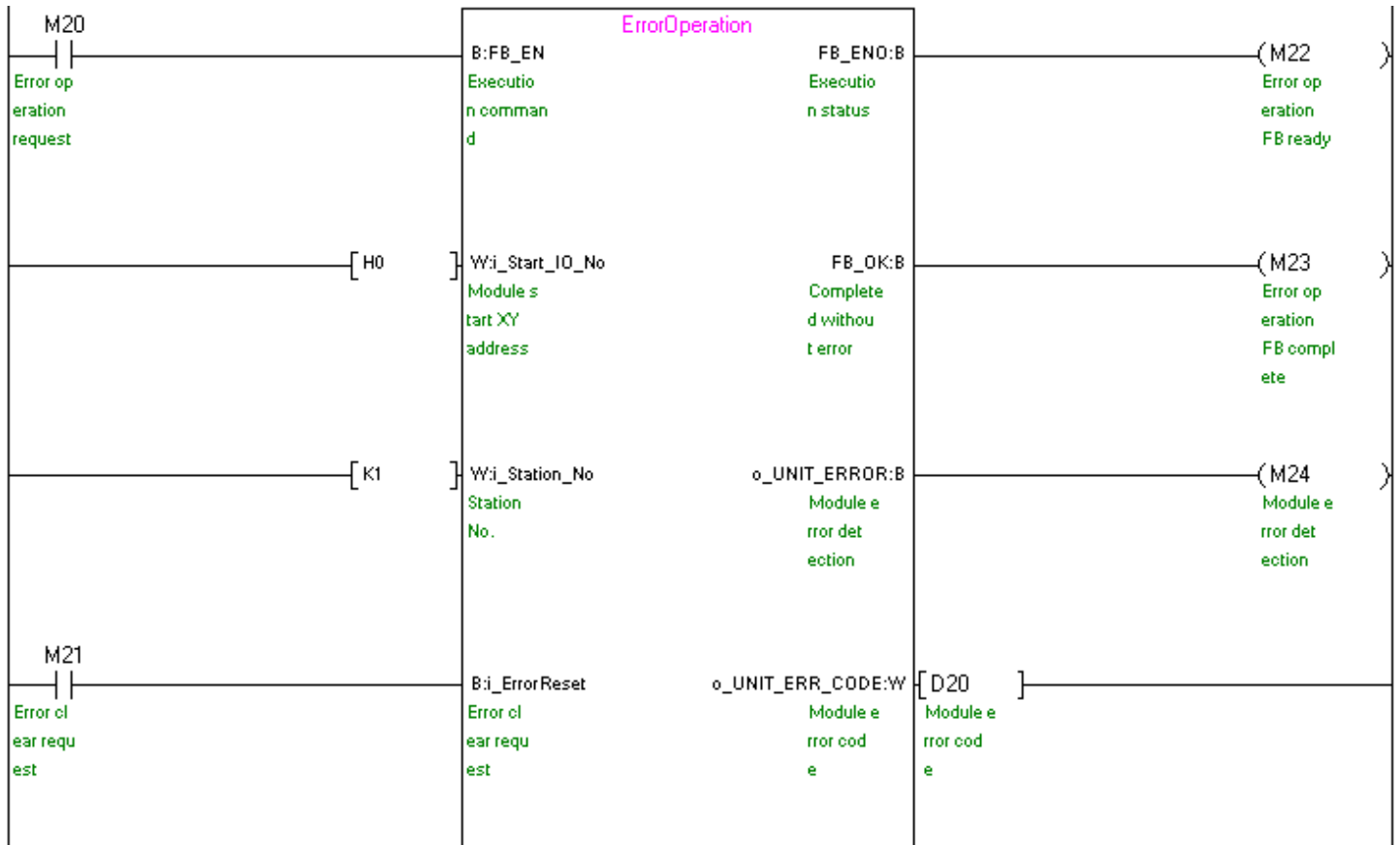

(Continues to the next page)

