

GOT1000

GT1020/GT1030 to FR-S500(E) Inverter

Start-up Guide

About this Manual

The texts, illustrations, diagrams and examples in this manual are only intended as aids to help explain the functioning, operation, use and programming of the GOT1000 terminals in combination with an FR-S500 Inverter.

If you have any questions regarding the installation and operation of the hardware described in this manual, please do not hesitate to contact your sales office or one of your Mitsubishi distribution partners.



CAUTION:

Do not attempt to install, operate, maintain or inspect the graphical operator terminal or the inverter until you have read through the corresponding instruction manual carefully and can use the equipment correctly. Do not use the inverter until you have a full knowledge of the equipment, safety information and instructions.

You can also obtain information and answers to frequently asked questions from our Mitsubishi website under www.mitsubishi-automation.com.

No part of this manual may be reproduced, copied, stored in any kind of information retrieval system or distributed without the prior express written consent of MITSUBISHI ELECTRIC.

mitsubishi electric reserves the right to change the specifications of its products and/or the contents of this manual at any time and without prior notice.

© Version A November 2008

Manual References:

Refer to the following manuals for more detailed explanations. For any further questions, please contact your local Mitsubishi Product Provider.

- GOT1000 Series Connection Manual 3/3 (SH(NA)-080532ENG), Sections 37.1 to 37.6
- FR-S 500, Frequency Inverter, Instruction Manual Detailed (IB(NA)-0600027-C)



CAUTION:

This Start-up Guide includes a brief summary of the main specifications of the GOT1000 graphic operation terminals and the FR-S500 series of inverters, which should be sufficient to enable experienced users to install and configure the units. For further information on the operation terminals and the inverters please refer to the above mentioned manuals.

Please observe also the safety precautions given in the manuals mentioned above.

Table of Contents

1 Overview	1
2 Hardware Introduction	1
3 Cabling	2
3.1 GOT and Inverter Wiring Diagrams	3
3.2 GOT Terminals	4
3.3 Programming Cables	4
4 GT Designer 2	5
5 Inverter Settings	7
6 Station Setting	7
6.1 Indirect Specification	8
7 Confirm Communication	8

1 Overview

This document provides a simple guide to setting up the GT1020 or GT1030 Graphic Operation Terminal (GOT) hardware and firmware for use with an FR-S500 Inverter.

2 Hardware Introduction

The GT1020 and GT1030 are monochrome, 3-color backlight, two communication channel GOT1000 Series touch panel interfaces used for capturing user input to a system.

It should be noted that not all products from the GT1020 or GT1030 range are compatible with a FREQROL inverter connection. Compatible products are identified in the table below

Model		Size	Backlight Colors	Comm. IF	Power
GT1020	-LBD	3.7" 160 x 64 dot	Green/Orange/Red	RS422	24 V DC
	-LBDW		White/Pink/Red		
GT1030	-LBD	4.5" 288 x 96 dot	Green/Orange/Red		
	-LBDW		White/Pink/Red		

Tab. 1: Specifications of the operator Terminals



For new GT1020 and GT1030 units, included in the box should be the following items:

- (A) GT1020/GT1030
- (B) 1 PLC Communication Connector
- (C) 1 rubber Panel Mounting Packing
- (D) 4 Panel Mounting Brackets

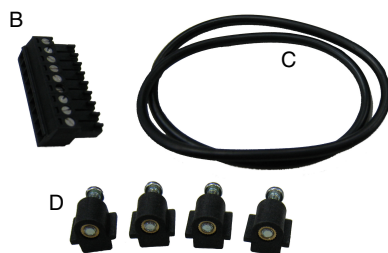

3 Cabling

Power

The applicable GT1020/GT1030 GOT require an external 24V DC power supply to be connected to the Power Terminal on the back of the GOT.

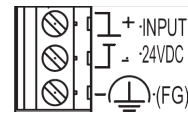

Communication

For the GT1020/GT1030 to communicate with the inverter, a communication cable is required. The type of cable used is dependent on the number of inverters used within the system, examples of which are illustrated below.

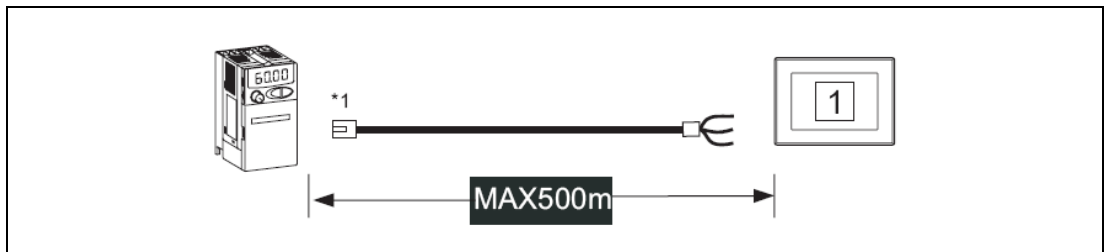

Fig. 1: One inverter connection

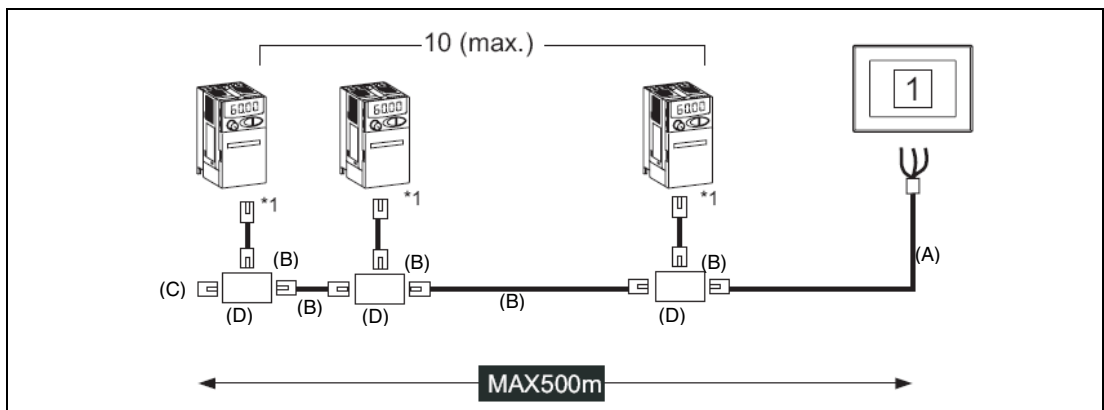

Fig. 2: Multi-drop connection

*1 Connect to the PU port of the inverter.

Discription to Fig. 2:

	A	B	C	D
Detailed view				
Standard	RS422	RS422	RS422	RS422
Meaning	Between inverter and GOT (to be made by user)	Between distributor and inverter or between distributors	Terminating resistor	Distributor

For an explanation of the communication cables please refer to the following section 3.1.

3.1 GOT and Inverter Wiring Diagrams

GOT side (terminal block)	Cable connection and signal direction	Inverter side or distributor side (Modular connector)		
Signal name		Pin No.	Signal name	Pin layout ^①
SDA		3	RDA	
SDB		6	RDB	
RDA		5	SDA	
RDB		4	SDB	
SG		1	SG	
RSA		2	P5S	
RSB	7	SG		
CSA	8	P5S		
CSB				

Tab. 2: RS-422 connection between inverter and GOT (Cable type A)

Distributor side (Modular connector)			Cable connection and signal direction	Inverter side or distributor side (Modular connector)		
Pin layout ^①	Signal name	Pin No.		Pin No.	Signal name	Pin layout ^①
	SDA	5		5	SDA	
	SDB	4		4	SDB	
	RDA	3		3	RDA	
	RDB	6		6	RDB	
	P5S	2		2	P5S	
	P5S	8		8	P5S	
	SG	1		1	SG	

Tab. 3: RS-422 connection distributor and inverter (Cable type B)

Distributor side			Cable connection and signal direction
Pin layout ^①	Signal name	Pin No.	
	SDA	5	
	SDB	4	
	RDA	3	
	RDB	6	
	P5S	2	
	P5S	8	
	SG	1	

Tab. 4: RS-422 connection for mounting a terminating resistor (Cable type C)

① The connector figure shows the engagement face.

3.2 GOT Terminals

The GT1020/GT1030 is fitted with screw terminals, use a small flathead screwdriver to secure the wires within the PLC Communication Connector.

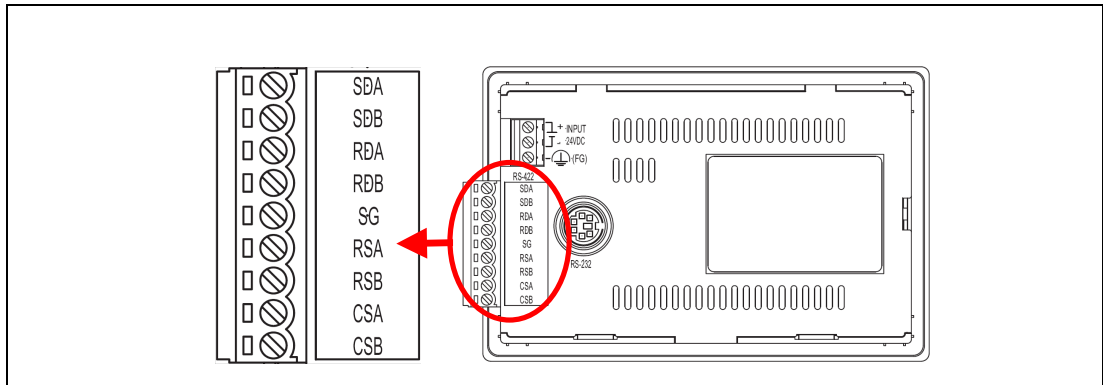

Fig. 3: Terminal points in detail

3.3 Programming Cables

The GT1020 and GT1030 come pre-installed with an OS and FX communication driver, but without any project data. To download a project from a PC running GT Designer2 to the GOT, a programming cable is required that connects to the RS-232C 6-pin Mini-DIN port on the back of the GOT. It is recommended to use a shielded USB A-type to Mini-B type cable with a ferrite core paired with the GT10-RS2TUSB-5S, but any RS-232C programming cable for the Q-Series will also work fine. A diagram of both is shown below.

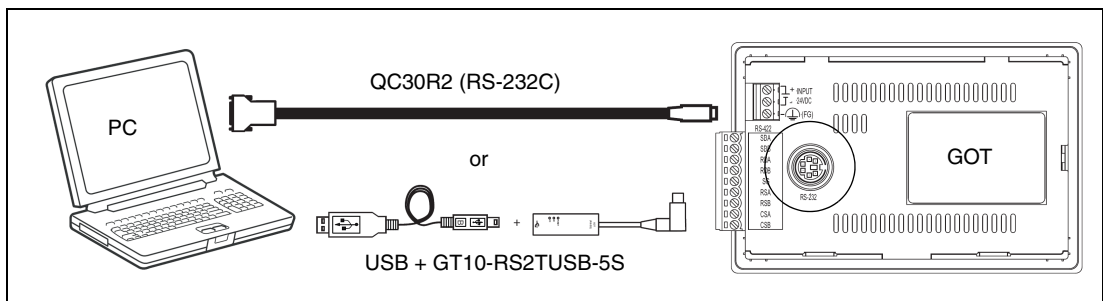

Fig. 4: Connection diagram

NOTE

Note that using the GT10-RS2TUSB-5S will require a virtual USB COM port driver to be installed on the PC. The COM port number can be automatically or manually assigned so that it does not overlap with the existing COM port numbers assigned on that PC. When using a Q-Series programming cable, the COM port number already assigned to the RS-232C interface of the PC will have to be checked.

4 GT Designer 2

(Version 2.73 or later)

To make sure the GT1020/GT1030 GOT is able to use the latest functions and features, it is the responsibility of the user to check and update the firmware (Standard monitor OS) of the GOT.

Launch the latest copy of GT Designer2 and start a new project for the corresponding GOT model (GT1020 or GT1030) with the “FREQROL500/700” Inverter Type. Select **Yes** to set the Communication Setting and make sure the Standard I/F-1 CH No. is set to 1 before selecting **OK**. The “Screen Property” window that pops up for making a new screen can be either canceled or accepted for the following steps.

Go to the “Communication” menu and select “To/From GOT” to bring up the “Communicate with GOT” window. Go to the “Communication configuration” tab and select “RS232” and the corresponding “Port No.” that connects the PC to the GOT. With the GOT power ON, use the **Test** button to verify that the PC and GOT can communicate properly then turn the GOT power OFF.

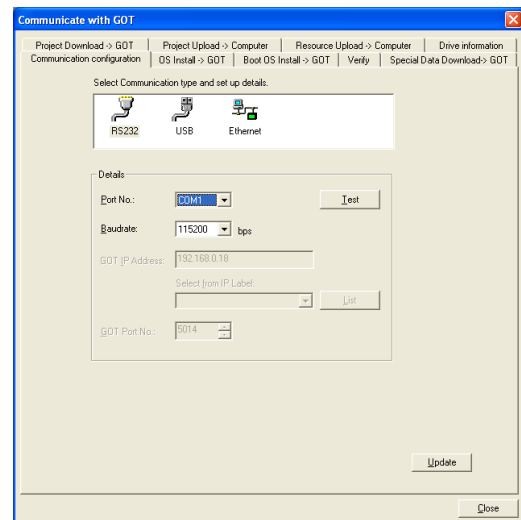

Installing OS and communication drivers

To access the OS installation mode of the GT1020/GT1030, switch the GOT power from OFF to ON, while holding the bottom right corner of the touch screen (in horizontal layout), illustrated in the figure at the right.

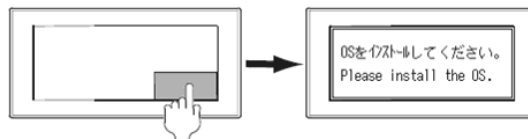

While the “Please install the OS” screen is displayed, go to the “OS Install -> GOT” tab in the “Communicate with GOT” window of GT Designer2 and select “Standard monitor OS” and select ‘FREQROL 500/700’ from the ‘Communication Driver’ menu. Use the **Install** button to initiate the data transfer and update the firmware. Once the firmware update has been completed the GOT will automatically reboot and all features will be up to date. Note that new project data will need to be downloaded to the GOT.

Make a selection like viewed on the right side under communication driver.

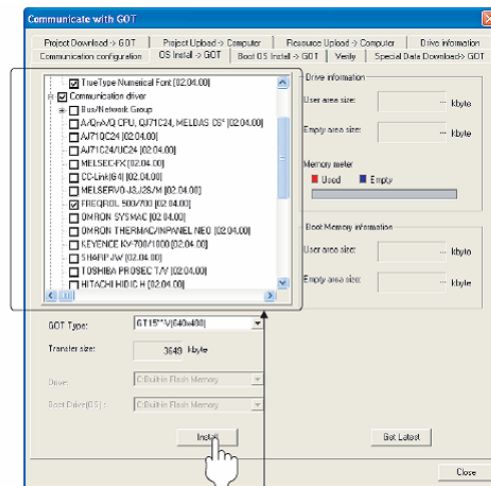

Select the following under communication driver

5 Inverter Settings

When setting the inverter communication parameters it is important to reset the power afterwards so that the settings are saved to the inverter.

The parameters shown in the following table must be set using the PU (Parameter Unit).

NOTE

Do not change these parameters, even though it is possible to monitor them through the GOT. If they are changed, communication with the GOT is disabled.

Setting item	Parameter	Set Value	Setting Contents
Communication Station number	n1	1-31	See following section
Communication Speed	n2	192	19200 bps
Stop bit length	n3	10	Data length: 7 bit Stop bit length: 1 bit
Parity check presence/absence	n4	1	Odd
Number of Communication retries	n5	–	The inverter will not come to an alarm stop.
Communication check time interval	n6	–	Communication check suspension
Wait time setting	n7	0	0ms
CR/LF selection	n11	1	With CR, without LF
Protocol selection	–	–	–
Operation mode selection	Pr.79	0	External operation modepower on
Link start mode selection	n10	1	Computer link operation
EEPROM write selection	n12	0	Written to RAM and EEPROM

Tab. 5: Inverter setting parameters

6 Station Setting

Set each station number while making sure that each station number is used only once.

The station number can be set regardless of the cable connection order.

Station numbers do not have to be consecutive.

The setting of the Station number has to be between 0-31.

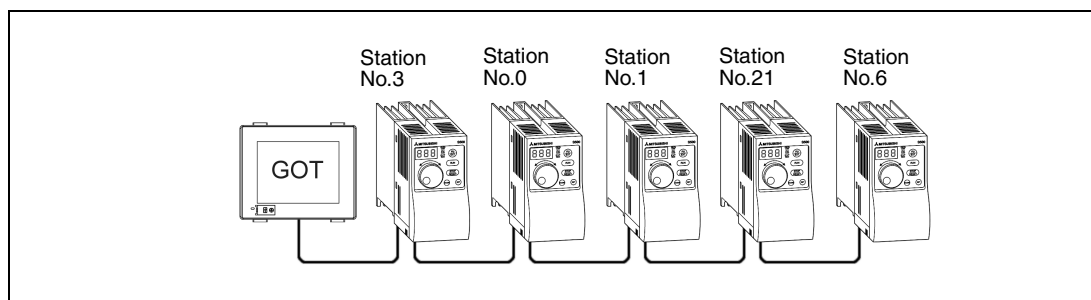

Fig. 5: Examples of station number setting

6.1 Indirect Specification

When setting the station number indirectly, the station number of the inverter can be changed using the 16-bit GOT internal data register (GD10 to GD25). When specifying the station No. from 100 to 155 on GT Designer 2, the value within GD10 to GD25 is equal to the station No.

Specification station no.	Compatible Device	Setting range
100	GD10	0 to 31 If the associated device contains a value outside this range an error (dedicated device is out of range) will occur.
101	GD11	
102	GD12	
103	GD13	
104	GD14	
105	GD15	
106	GD16	
107	GD17	
108	GD18	
109	GD19	
110	GD20	
111	GD21	
112	GD22	
113	GD23	
114	GD24	
115	GD25	

Tab. 6: Specification of the station number

7 Confirm Communication

The communication monitoring is a function that checks whether the GOT can communicate with the Inverter. If no error is shown, communication has been set up correctly.

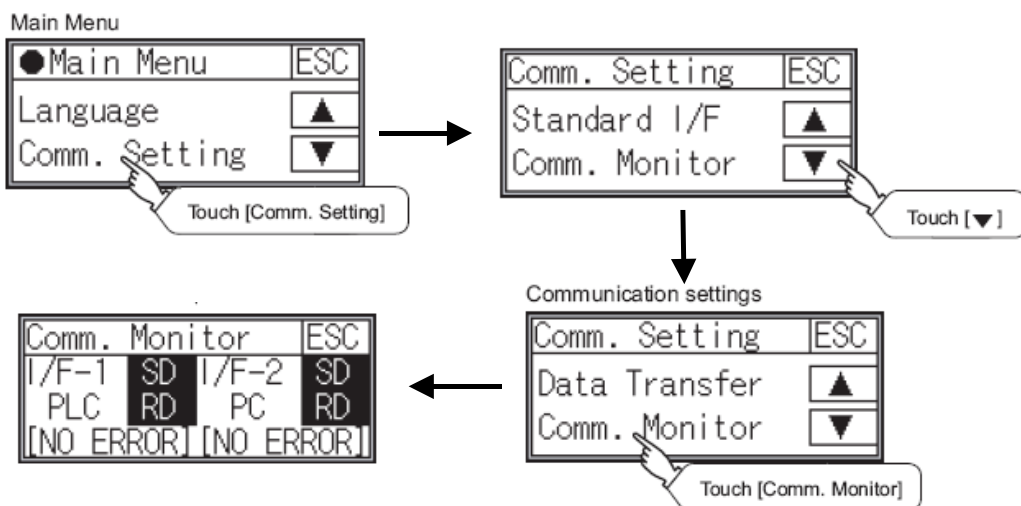

HEADQUARTERS

MITSUBISHI ELECTRIC EUROPE B.V. **EUROPE**
 German Branch
 Gothaer Straße 8
D-40880 Ratingen
 Phone: +49 (0)2102 / 486-0
 Fax: +49 (0)2102 / 486-1120

MITSUBISHI ELECTRIC EUROPE B.V. **CZECH REPUBLIC**
 Czech Branch
 Radlicka 714/113 a
CZ-158 00 Praha 5
 Phone: +420 251 551 470
 Fax: +420-251-551-471

MITSUBISHI ELECTRIC EUROPE B.V. **FRANCE**
 French Branch
 25, Boulevard des Bouvets
F-92741 Nanterre Cedex
 Phone: +33 (0)1 / 55 68 55 68
 Fax: +33 (0)1 / 55 68 57 57

MITSUBISHI ELECTRIC EUROPE B.V. **IRELAND**
 Irish Branch
 Westgate Business Park, Ballymount
IRL-Dublin 24
 Phone: +353 (0)1 4198800
 Fax: +353 (0)1 4198890

MITSUBISHI ELECTRIC EUROPE B.V. **ITALY**
 Italian Branch
 Viale Colleoni 7
I-20041 Agrate Brianza (MI)
 Phone: +39 039 / 60 53 1
 Fax: +39 039 / 60 53 312

MITSUBISHI ELECTRIC EUROPE B.V. **SPAIN**
 Spanish Branch
 Carretera de Rubí 76-80
E-08190 Sant Cugat del Vallés (Barcelona)
 Phone: 902 131121 // +34 935653131
 Fax: +34 935891579

MITSUBISHI ELECTRIC EUROPE B.V. **UK**
 UK Branch
 Travellers Lane
UK-Hatfield, Herts. AL10 8XB
 Phone: +44 (0)1707 / 27 61 00
 Fax: +44 (0)1707 / 27 86 95

MITSUBISHI ELECTRIC CORPORATION **JAPAN**
 Office Tower "Z" 14 F
 8-12,1 chome, Harumi Chuo-Ku
Tokyo 104-6212
 Phone: +81 3 622 160 60
 Fax: +81 3 622 160 75

MITSUBISHI ELECTRIC AUTOMATION, Inc. **USA**
 500 Corporate Woods Parkway
Vernon Hills, IL 60061
 Phone: +1 847 478 21 00
 Fax: +1 847 478 22 53

EUROPEAN REPRESENTATIVES

GEVA **AUSTRIA**
 Wiener Straße 89
AT-2500 Baden
 Phone: +43 (0)2252 / 85 55 20
 Fax: +43 (0)2252 / 488 60

TEHNIKON **BELARUS**
 Oktyabrskaya 16/5, Off. 703-711
BY-220030 Minsk
 Phone: +375 (0)17 / 210 46 26
 Fax: +375 (0)17 / 210 46 26

Koning & Hartman b.v. **BELGIUM**
 Woluwelaan 31
BE-1800 Vilvoorde
 Phone: +32 (0)2 / 257 02 40
 Fax: +32 (0)2 / 257 02 49

AKHNATON **BULGARIA**
 4 Andrej Ljapchev Blvd. Pb 21
BG-1756 Sofia
 Phone: +359 (0)2 / 817 6004
 Fax: +359 (0)2 / 97 44 06 1

INEA CR d.o.o. **CROATIA**
 Losinjska 4 a
HR-10000 Zagreb
 Phone: +385 (0)1 / 36 940 - 01 / -02 / -03
 Fax: +385 (0)1 / 36 940 - 03

AutoCont C.S., s.r.o. **CZECH REPUBLIC**
 Technologická 374/6
CZ-708 00 Ostrava Pustkovec
 Phone: +420 (0)59 / 5691 150
 Fax: +420 (0)59 / 5691 199

B:TECH, a.s. **CZECH REPUBLIC**
 U Borove 69
CZ-58001 Havlickuv Brod
 Phone: +420 (0)569 777 777
 Fax: +420 (0)569-777 778

Beijer Electronics A/S **DENMARK**
 Lykkegårdsvej 17, 1.
DK-4000 Roskilde
 Phone: +45 (0)46 / 75 76 66
 Fax: +45 (0)46 / 75 56 26

Beijer Electronics Eesti OÜ **ESTONIA**
 Pärnu mnt.160i
EE-11317 Tallinn
 Phone: +372 (0)6 / 51 81 40
 Fax: +372 (0)6 / 51 81 49

Beijer Electronics OY **FINLAND**
 Jaakonkatu 2
FIN-01620 Vantaa
 Phone: +358 (0)207 / 463 500
 Fax: +358 (0)207 / 463 501

UTEKO A.B.E.E. **GREECE**
 5, Mavrogenous Str.
GR-18542 Piraeus
 Phone: +30 211 / 1206 900
 Fax: +30 211 / 1206 999

MELTRADE Ltd. **HUNGARY**
 Fertő utca 14.
HU-1107 Budapest
 Phone: +36 (0)1 / 431-9726
 Fax: +36 (0)1 / 431-9727

Beijer Electronics SIA **LATVIA**
 Vestienas iela 2
LV-1035 Riga
 Phone: +371 (0)784 / 2280
 Fax: +371 (0)784 / 2281

Beijer Electronics UAB **LITHUANIA**
 Savanoriu Pr. 187
LT-02300 Vilnius
 Phone: +370 (0)5 / 232 3101
 Fax: +370 (0)5 / 232 2980

EUROPEAN REPRESENTATIVES

INTEHSIS srl **MOLDOVA**
 bld. Traian 23/1
MD-2060 Kishinev
 Phone: +373 (0)22 / 66 4242
 Fax: +373 (0)22 / 66 4280

Koning & Hartman b.v. **NETHERLANDS**
 Haarlerbergweg 21-23
NL-1101 CH Amsterdam
 Phone: +31 (0)20 / 587 76 00
 Fax: +31 (0)20 / 587 76 05

Beijer Electronics AS **NORWAY**
 Postboks 487
NO-3002 Drammen
 Phone: +47 (0)32 / 24 30 00
 Fax: +47 (0)32 / 84 85 77

MPL Technology Sp. z o.o. **POLAND**
 Ul. Krakowska 50
PL-32-083 Balice
 Phone: +48 (0)12 / 630 47 00
 Fax: +48 (0)12 / 630 47 01

Sirius Trading & Services srl **ROMANIA**
 Aleea Lacul Morii Nr. 3
RO-060841 Bucuresti, Sector 6
 Phone: +40 (0)21 / 430 40 06
 Fax: +40 (0)21 / 430 40 02

Craft Con. & Engineering d.o.o. **SERBIA**
 Bulevar Svetog Cara Konstantina 80-86
SER-18106 Nis
 Phone: +381 (0)18 / 292-24-4/5, 523 962
 Fax: +381 (0)18 / 292-24-4/5, 523 962

INEA SR d.o.o. **SERBIA**
 Karadjordjeva 12/260
SER-113000 Smederevo
 Phone: +381 (0)26 / 617 163
 Fax: +381 (0)26 / 617 163

AutoCont Control, s.r.o. **SLOVAKIA**
 Radlinského 47
SK-02601 Dolny Kubin
 Phone: +421 (0)43 / 5868210
 Fax: +421 (0)43 / 5868210

CS MTrade Slovensko, s.r.o. **SLOVAKIA**
 Vajanskeho 58
SK-92101 Piestany
 Phone: +421 (0)33 / 7742 760
 Fax: +421 (0)33 / 7735 144

INEA d.o.o. **SLOVENIA**
 Stegne 11
SI-1000 Ljubljana
 Phone: +386 (0)1 / 513 8100
 Fax: +386 (0)1 / 513 8170

Beijer Electronics Automation AB **SWEDEN**
 Box 426
SE-20124 Malmö
 Phone: +46 (0)40 / 35 86 00
 Fax: +46 (0)40 / 35 86 02

Econotec AG **SWITZERLAND**
 Hinterdorfstr. 12
CH-8309 Nürensdorf
 Phone: +41 (0)44 / 838 48 11
 Fax: +41 (0)44 / 838 48 12

GTS **TURKEY**
 Darulaceze Cad. No. 43 KAT. 2
TR-34384 Okmeydani-Istanbul
 Phone: +90 (0)212 / 320 1640
 Fax: +90 (0)212 / 320 1649

CSC Automation Ltd. **UKRAINE**
 15, M. Raskova St., Fl. 10, Office 1010
UA-02002 Kiev
 Phone: +380 (0)44 / 494 33 55
 Fax: +380 (0)44 / 494-33-66

EURASIAN REPRESENTATIVES

Kazpromautomatics Ltd. **KAZAKHSTAN**
 Mustafina Str. 7/2
KAZ-470046 Karaganda
 Phone: +7 7212 / 50 11 50
 Fax: +7 7212 / 50 11 50

CONSUS **RUSSIA**
 Promyshlennaya st. 42
RU-198099 St. Petersburg
 Phone: +7 812 / 325 36 53
 Fax: +7 812 / 325 36 53

Drive Technique STC **RUSSIA**
 1-st Magistralny tupik, 10, bld 1
RU-123290 Moscow
 Phone: +7 495 / 786-21 00
 Fax: +7 495 / 786-21 01

ELECTROTECHNICAL SYSTEMS **RUSSIA**
 Derbenevskaya st. 11A, Office 69
RU-115114 Moscow
 Phone: +7 495 / 744 55 54
 Fax: +7 495 / 744 55 54

ELEKTROSTILY **RUSSIA**
 Rubzovskaja nab. 4-3, No. 8
RU-105082 Moscow
 Phone: +7 495 / 545 3419
 Fax: +7 495 / 545 3419

RPS-AUTOMATIKA **RUSSIA**
 Budenovskiy 97, Office 311
RU-344007 Rostov on Don
 Phone: +7 8632 / 22 63 72
 Fax: +7 8632 / 219 45 51

MIDDLE EAST REPRESENTATIVE

SHERF Motion Techn. Ltd. **ISRAEL**
 Rehov Hamerkava 19
IL-58851 Holon
 Phone: +972 (0)3 / 559 54 62
 Fax: +972 (0)3 / 556 01 82

AFRICAN REPRESENTATIVE

CBI Ltd. **SOUTH AFRICA**
 Private Bag 2016
ZA-1600 Isando
 Phone: +27 (0)11 / 928 2000
 Fax: +27 (0)11 / 392 2354