

MELFA

Industrial Robots

Instruction Manual

RV-2A/RV-3AJ

Safety Precautions

Always read the following precautions and the separate "Safety Manual" before starting use of the robot to learn the required measures to be taken.

CAUTION

All teaching work must be carried out by an operator who has received special training. (This also applies to maintenance work with the power source turned ON.)
→ Enforcement of safety training

CAUTION

For teaching work, prepare a work plan related to the methods and procedures of operating the robot, and to the measures to be taken when an error occurs or when restarting. Carry out work following this plan. (This also applies to maintenance work with the power source turned ON.)
→ Preparation of work plan

WARNING

Prepare a device that allows operation to be stopped immediately during teaching work. (This also applies to maintenance work with the power source turned ON.)
→ Setting of emergency stop switch

CAUTION

During teaching work, place a sign indicating that teaching work is in progress on the start switch, etc. (This also applies to maintenance work with the power source turned ON.)
→ Indication of teaching work in progress

WARNING

Provide a fence or enclosure during operation to prevent contact of the operator and robot.
→ Installation of safety fence

CAUTION

Establish a set signaling method to the related operators for starting work, and follow this method.
→ Signaling of operation start

















CAUTION

As a principle turn the power OFF during maintenance work. Place a sign indicating that maintenance work is in progress on the start switch, etc.
→ Indication of maintenance work in progress

CAUTION

Before starting work, inspect the robot, emergency stop switch and other related devices, etc., and confirm that there are no errors.
→ Inspection before starting work

The points of the precautions given in the separate "Safety Manual" are given below. Refer to the actual "Safety Manual" for details.

-  **CAUTION** Use the robot within the environment given in the specifications. Failure to do so could lead to a drop or reliability or faults. (Temperature, humidity, atmosphere, noise environment, etc.)
-  **CAUTION** Transport the robot with the designated transportation posture. Transporting the robot in a non-designated posture could lead to personal injuries or faults from dropping.
-  **CAUTION** Always use the robot installed on a secure table. Use in an instable posture could lead to positional deviation and vibration.
-  **CAUTION** Wire the cable as far away from noise sources as possible. If placed near a noise source, positional deviation or malfunction could occur.
-  **CAUTION** Do not apply excessive force on the connector or excessively bend the cable. Failure to observe this could lead to contact defects or wire breakage.
-  **CAUTION** Make sure that the workpiece weight, including the hand, does not exceed the rated load or tolerable torque. Exceeding these values could lead to alarms or faults.
-  **WARNING** Securely install the hand and tool, and securely grasp the workpiece. Failure to observe this could lead to personal injuries or damage if the object comes off or flies off during operation.
-  **WARNING** Securely ground the robot and controller. Failure to observe this could lead to malfunctioning by noise or to electric shock accidents.
-  **CAUTION** Indicate the operation state during robot operation. Failure to indicate the state could lead to operators approaching the robot or to incorrect operation.
-  **WARNING** When carrying out teaching work in the robot's movement range, always secure the priority right for the robot control. Failure to observe this could lead to personal injuries or damage if the robot is started with external commands.
-  **CAUTION** Keep the jog speed as low as possible, and always watch the robot. Failure to do so could lead to interference with the workpiece or peripheral devices.
-  **CAUTION** After editing the program, always confirm the operation with step operation before starting automatic operation. Failure to do so could lead to interference with peripheral devices because of programming mistakes, etc.
-  **CAUTION** Make sure that if the safety fence entrance door is opened during automatic operation, the door is locked or that the robot will automatically stop. Failure to do so could lead to personal injuries.
-  **CAUTION** Never carry out modifications based on personal judgments, or use non-designated maintenance parts.
Failure to observe this could lead to faults or failures.
-  **WARNING** When the robot arm has to be moved by hand from an external area, do not place hands or fingers in the openings. Failure to observe this could lead to hands or fingers catching depending on the posture.
-  **CAUTION** Do not stop the robot or apply emergency stop by turning the robot controller's main power OFF.
If the robot controller main power is turned OFF during automatic operation, the robot accuracy could be adversely affected.

C.Precautions for the basic configuration are shown below.(When CR1-571 is used for the controller.)

⚠ CAUTION

Provide an earth leakage breaker that packed together on the primary power supply of the controller as protection against electric leakage. Confirm the setting connector of the input power supply voltage of the controller, if the type which more than one power supply voltage can be used. Then connect the power supply.
Failure to do so could lead to electric shock accidents.

Power supply *RV-1A/2AJ series and RP-1AH/3AH/5AH series: Single phase 90-132VAC, 180-253VAC.
*Except the above: Single phase 180-253VAC.

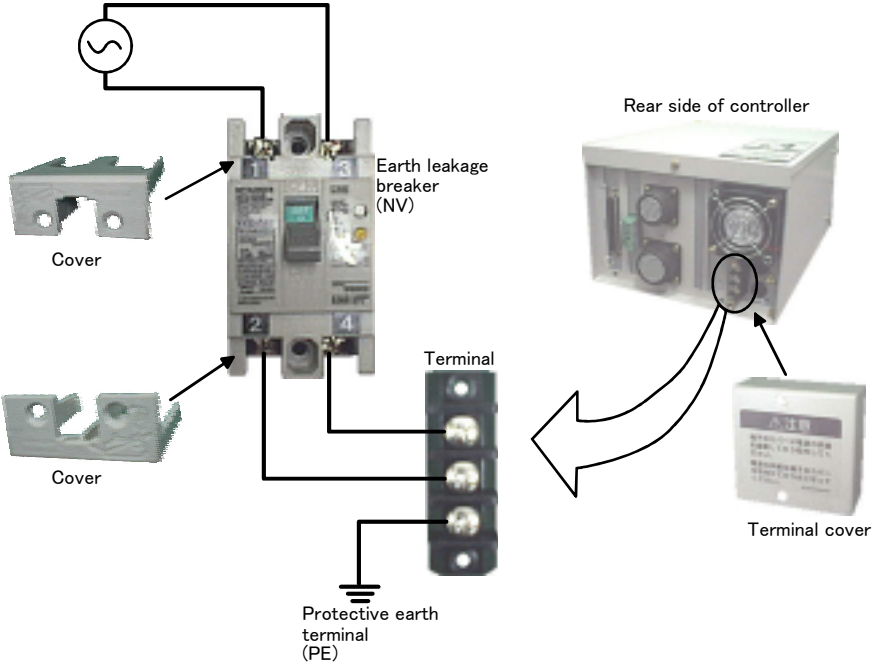

Revision history

Date of Point	Instruction Manual No.	Revision Details
2001-09-11	BFP-A8183Z	First print
2001-09-25	BFP-A8183	Formal style
2001-12-06	BFP-A8183-A	The explanation of the attached part of packing was added. Error in writing correction.
2002-04-23	BFP-A8183-B	Error in writing correction.

■ Introduction

Thank you for purchasing the Mitsubishi industrial robot.

This instruction manual explains procedures to be taken for unpacking, installing, servicing and inspecting the robot arm.

Always read through this manual before starting use to ensure correct usage of the robot.

- No part of this manual may be reproduced by any means or in any form, without prior consent from Mitsubishi.
- The details of this manual are subject to change without notice.
- An effort has been made to make full descriptions in this manual. However, if any discrepancies or unclear points are found, please contact your dealer.
- The information contained in this document has been written to be accurate as much as possible. Please interpret that items not described in this document "cannot be performed". Please contact your nearest dealer if you find any doubtful, wrong or skipped point.

CONTENTS

Page

1	Before starting use	1-1
1.1	Using the instruction manuals	1-1
1.1.1	The details of each instruction manuals	1-1
1.1.2	Symbols used in instruction manual	1-2
1.2	Safety Precautions	1-3
1.2.1	Precautions given in the separate Safety Manual	1-4
2	Unpacking to Installation	2-5
2.1	Confirming the product	2-5
2.2	Installation	2-6
2.2.1	Unpacking	2-6
2.2.2	Transportation procedures(Transportation by people)	2-7
2.2.3	Installation procedures	2-8
2.2.4	Grounding procedures	2-9
(1)	Grounding methods	2-9
(2)	Grounding procedures	2-9
2.2.5	Connecting with the controller	2-10
2.3	Setting the origin	2-11
2.3.1	Installing the teaching pendant (T/B)	2-11
(1)	Installing with the control power OFF	2-11
2.3.2	Setting the origin with the origin data input method	2-12
(1)	Confirming the origin data	2-12
(2)	Turning ON the control power	2-12
(3)	Preparing the T/B	2-13
(4)	Selecting the origin setting method	2-14
(5)	Inputting the origin data	2-15
(6)	Installing the shoulder cover (B)	2-16
2.4	Confirming the operation	2-17
(1)	JOINT jog operation	2-20
(2)	XYZ jog operation	2-22
(3)	TOOL jog operation	2-24
(4)	3-axis XYZ jog operation	2-26
(5)	CYLINDER jog operation	2-28
3	Installing the option devices	3-31
3.1	Installing the solenoid valve set(1E-VD01/VD01E/VD02/VD02E)	3-31
3.1.1	RV-2A, RV-3AJ (General environment)	3-31
3.1.2	RV-2AM, RV-3AJM (Protection specification)	3-33
3.2	Installation the pneumatic hand set (4A-HP02/HP02E)	3-35
3.2.1	Installing the 1E-HP01/1E-HP01E pneumatic hand	3-36
3.2.2	Installing the 1E-VD01/1E-VD01E solenoid valve set	3-36
3.2.3	Installing the pneumatic hand interface	3-36
3.2.4	Setting the parameters	3-36
3.2.5	Open/close setting of the hand and settings for input signals	3-36
3.2.6	Confirming operability	3-36
3.3	Installation the motorized hand set (4A-HM02)	3-37
3.3.1	Installing the motorized hand	3-38
3.3.2	Installation the motorized interface	3-38
3.3.3	Setting the parameters	3-38
3.3.4	Confirming operability	3-38
3.4	Hand output cable (1E-GR35S)	3-39
3.5	Installing the hand input cable (1E-HC15C) and hand curl tube (1E-ST040*C)	3-39
4	Basic operations	4-41
5	Maintenance and Inspection	5-43

5.1 Maintenance and inspection interval	5-43
5.2 Inspection items	5-44
5.2.1 Daily inspection items	5-44
5.2.2 Periodic inspection	5-45
5.3 Maintenance and inspection procedures	5-46
5.3.1 Robot arm structure	5-46
5.3.2 Installing/removing the cover	5-48
5.3.3 Inspection, maintenance and replacement of timing belt	5-50
(1) Timing belt replacement period	5-50
(2) Inspection, maintenance and replacement of J5-axis timing belt	5-51
(3) Timing belt tension	5-52
5.3.4 Cleaning inside the cover of clean specification (RV-2AC-SA/SB, RV-3AJC-SA/SB)	5-53
5.3.5 Lubrication	5-54
(1) Lubrication position and specifications	5-54
(2) Reduction gears lubrication method	5-56
(3) Oil seal section lubrication method (for only clean specification)	5-60
5.3.6 How to lubricate the spring shaft area	5-62
5.3.7 Replacing the backup battery	5-63
(1) Replacing the robot arm battery	5-63
5.4 Maintenance parts	5-65
5.5 Resetting the origin	5-66
5.5.1 Mechanical stopper method	5-67
(1) Select the T/B	5-67
(2) J1 axis origin setting	5-68
(3) J2 axis origin setting	5-69
(4) J3 axis origin setting	5-70
(5) J4 axis origin setting (Only 6-axis type)	5-72
(6) J5 axis origin setting	5-74
(7) J6 axis origin setting	5-75
(8) All axis origin setting	5-77
5.5.2 Jig method	5-78
5.5.3 User origin method	5-81
5.5.4 ABS origin method	5-83
(1) Select the T/B	5-83
5.5.5 Recording the origin data	5-84
(1) Confirming the origin data label	5-84
(2) Confirming the origin data	5-84
(3) Recording the origin data	5-84
(4) Installing the cover	5-84
6Appendix	Appendix-85
Appendix 1 : Configuration flag	Appendix-85

1 Before starting use

This chapter explains the details and usage methods of the instruction manuals, the basic terminology and the safety precautions.

1.1 Using the instruction manuals

1.1.1 The details of each instruction manuals

The contents and purposes of the documents enclosed with this product are shown below. Use these documents according to the application.



For special specifications, a separate instruction manual describing the special section may be enclosed.

Safety Manual	Explains the common precautions and safety measures to be taken for robot handling, system design and manufacture to ensure safety of the operators involved with the robot.
Standard Specifications	Explains the product's standard specifications, factory-set special specifications, option configuration and maintenance parts, etc. Precautions for safety and technology, when incorporating the robot, are also explained.
Robot Arm Setup & Maintenance	Explains the procedures required to operate the robot arm (unpacking, transportation, installation, confirmation of operation), and the maintenance and inspection procedures.
Controller Setup, Basic Operation and Maintenance	Explains the procedures required to operate the controller (unpacking, transportation, installation, confirmation of operation), basic operation from creating the program to automatic operation, and the maintenance and inspection procedures.
Detailed Explanation of Functions and Operations	Explains details on the functions and operations such as each function and operation, commands used in the program, connection with the external input/output device, and parameters, etc.
Explanations of MOVEMASTER COMMANDS	Explains details on the MOVEMASTER commands used in the program. (For RV-1A/2AJ and RV-2A/3AJ series)
Troubleshooting	Explains the causes and remedies to be taken when an error occurs. Explanations are given for each error No.

1.1.2 Symbols used in instruction manual









The symbols and expressions shown in [Table 1-1](#) are used throughout this User's Manual. Learn the meaning of these symbols before reading this instruction manual.

Table 1-1 : Symbols in instruction manual

Symbol	Meaning
 DANGER	Precaution indicating cases where there is a risk of operator fatality or serious injury if handling is mistaken. Always observe these precautions to safely use the robot.
 WARNING	Precaution indicating cases where the operator could be subject to fatalities or serious injuries if handling is mistaken. Always observe these precautions to safely use the robot.
 CAUTION	Precaution indicating cases where operator could be subject to injury or physical damage could occur if handling is mistaken. Always observe these precautions to safely use the robot.
[JOINT]	If a word is enclosed in brackets or a box in the text, this refers to a key on the teaching pendant.
[+ / FORWD] + [+ X] (A) (B)	This indicates to press the (B) key while holding down the (A) key. In this example, the [+ / Forward] key is pressed while holding down the [+X / +Y] key.
[STEP / MOVE] + ([COND] → [RPL ↓]) (A) (B) (C)	This indicates to hold down the (A) key, press and release the (B) key, and then press the (C) key. In this example, the [Step / Move] key is held down, the [Condition] key is pressed and released, and the [Replace ↓] key is pressed.
T / B	This indicates the teaching pendant.



1.2 Safety Precautions

Always read the following precautions and the separate "Safety Manual" before starting use of the robot to learn the required measures to be taken.

-  **CAUTION** All teaching work must be carried out by an operator who has received special training. (This also applies to maintenance work with the power source turned ON.)
→ Enforcement of safety training
-  **CAUTION** For teaching work, prepare a work plan related to the methods and procedures of operating the robot, and to the measures to be taken when an error occurs or when restarting. Carry out work following this plan. (This also applies to maintenance work with the power source turned ON.)
→ Preparation of work plan
-  **WARNING** Prepare a device that allows operation to be stopped immediately during teaching work. (This also applies to maintenance work with the power source turned ON.)
→ Setting of emergency stop switch
-  **CAUTION** During teaching work, place a sign indicating that teaching work is in progress on the start switch, etc. (This also applies to maintenance work with the power source turned ON.)
→ Indication of teaching work in progress
-  **DANGER** Provide a fence or enclosure during operation to prevent contact of the operator and robot.
→ Installation of safety fence
-  **CAUTION** Establish a set signaling method to the related operators for starting work, and follow this method.
→ Signaling of operation start
-  **CAUTION** As a principle turn the power OFF during maintenance work. Place a sign indicating that maintenance work is in progress on the start switch, etc.
→ Indication of maintenance work in progress
-  **CAUTION** Before starting work, inspect the robot, emergency stop switch and other related devices, etc., and confirm that there are no errors.
→ Inspection before starting work

1.2.1 Precautions given in the separate Safety Manual

The points of the precautions given in the separate "Safety Manual" are given below. Refer to the actual "Safety Manual" for details.

-  **CAUTION** Use the robot within the environment given in the specifications. Failure to do so could lead to a drop or reliability or faults. (Temperature, humidity, atmosphere, noise environment, etc.)
-  **CAUTION** Transport the robot with the designated transportation posture. Transporting the robot in a non-designated posture could lead to personal injuries or faults from dropping.
-  **CAUTION** Always use the robot installed on a secure table. Use in an instable posture could lead to positional deviation and vibration.
-  **CAUTION** Wire the cable as far away from noise sources as possible. If placed near a noise source, positional deviation or malfunction could occur.
-  **CAUTION** Do not apply excessive force on the connector or excessively bend the cable. Failure to observe this could lead to contact defects or wire breakage.
-  **CAUTION** Make sure that the workpiece weight, including the hand, does not exceed the rated load or tolerable torque. Exceeding these values could lead to alarms or faults.
-  **WARNING** Securely install the hand and tool, and securely grasp the workpiece. Failure to observe this could lead to personal injuries or damage if the object comes off or flies off during operation.
-  **WARNING** Securely ground the robot and controller. Failure to observe this could lead to malfunctioning by noise or to electric shock accidents.
-  **CAUTION** Indicate the operation state during robot operation. Failure to indicate the state could lead to operators approaching the robot or to incorrect operation.
-  **WARNING** When carrying out teaching work in the robot's movement range, always secure the priority right for the robot control. Failure to observe this could lead to personal injuries or damage if the robot is started with external commands.
-  **CAUTION** Keep the jog speed as low as possible, and always watch the robot. Failure to do so could lead to interference with the workpiece or peripheral devices.
-  **CAUTION** After editing the program, always confirm the operation with step operation before starting automatic operation. Failure to do so could lead to interference with peripheral devices because of programming mistakes, etc.
-  **CAUTION** Make sure that if the safety fence entrance door is opened during automatic operation, the door is locked or that the robot will automatically stop. Failure to do so could lead to personal injuries.
-  **CAUTION** Never carry out modifications based on personal judgments, or use non-designated maintenance parts.
Failure to observe this could lead to faults or failures.
-  **WARNING** When the robot arm has to be moved by hand from an external area, do not place hands or fingers in the openings. Failure to observe this could lead to hands or fingers catching depending on the posture.
-  **CAUTION** Do not stop the robot or apply emergency stop by turning the robot controller's main power OFF.
If the robot controller main power is turned OFF during automatic operation, the robot accuracy could be adversely affected.

2 Unpacking to Installation

2.1 Confirming the product

The standard configuration of the robot arm, part of the purchased product, is shown in [Table 2-1](#).

Confirm the parts.

Users who have purchased optional products should refer to the separate “Standard Specifications”.

Table 2-1 : Standard configuration

No.	Part name	Type	Qty.	Remarks
1	Robot arm	RV-2A, RV-2AM, RV-2AC-SA/SB RV-3AJ, RV-3AJM, or RV-3AJC-SA/SB	Either 1 unit	
2	Guarantee card		1 copy	
3	Installation bolts	M8x30	4 pcs.	For robot arm installation
4	Spring washer for installation bolts	For M8	4 pcs.	
5	Plain washer for installation bolts	For M8	4 pcs.	
6	Marking seals		12 pcs.	

Note) The number 3 – 6 are in the plastic bag of the robot arm attachment.

2.2 Installation

2.2.1 Unpacking

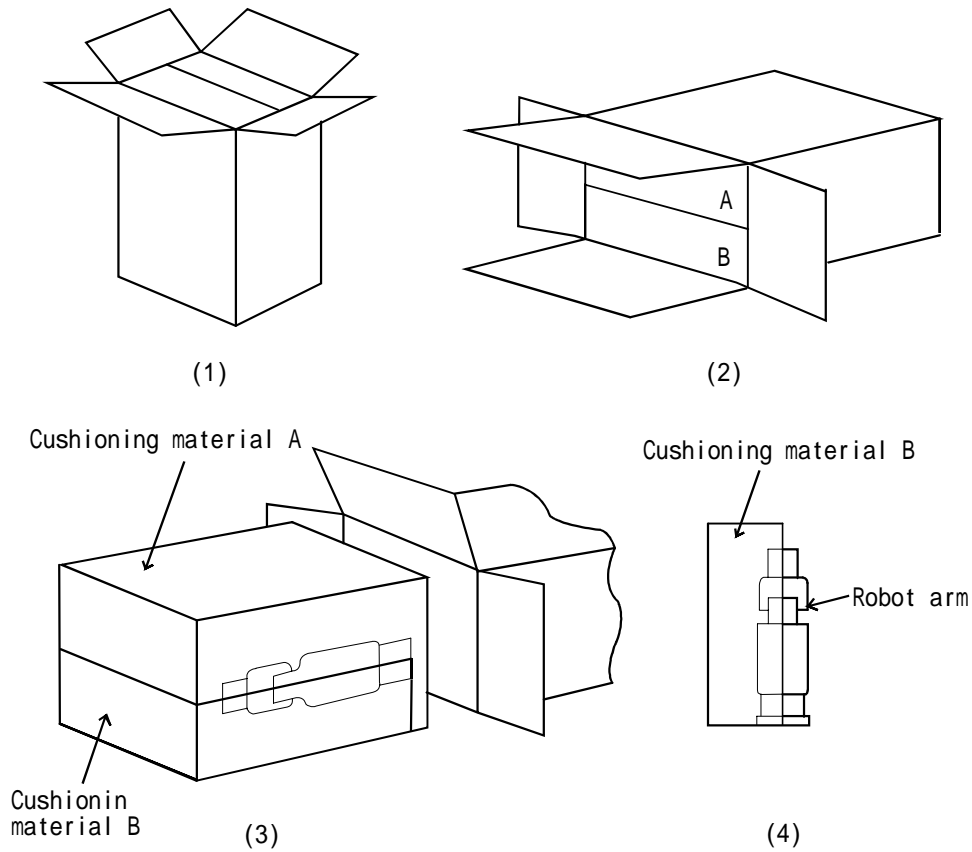

Note) The cushioning material will be required if the robot is transported again , so save it in a safe place.

Fig.2-1 : Unpacking the robot arm

The robot is shipped from the factory in cardboard packing. Always refer to [Fig. 2-1](#) and unpack the robot. Handle the robot arm according to ["2.2.2 Transportation procedures\(Transportation by people\)"](#)

The unpacking process is shown below.

- 1) Open the top of the cardboard box.
- 2) As shown in [Fig. 2-1 \(2\)](#), lay the box gently down so that the unpacking instructions on the top cover faces down.
- 3) Pull the cushioning material A, and B, which encloses the robot arm, out of the cardboard box, as shown in [Fig. 2-1 \(3\)](#).
- 4) Remove the cushioning material A.
- 5) While keeping the robot enclosed in cushioning material B, stand up the robot arm as shown in [Fig. 2-1 \(4\)](#).
- 6) Remove the cushioning material B from the robot to complete the unpacking process.

2.2.2 Transportation procedures(Transportation by people)

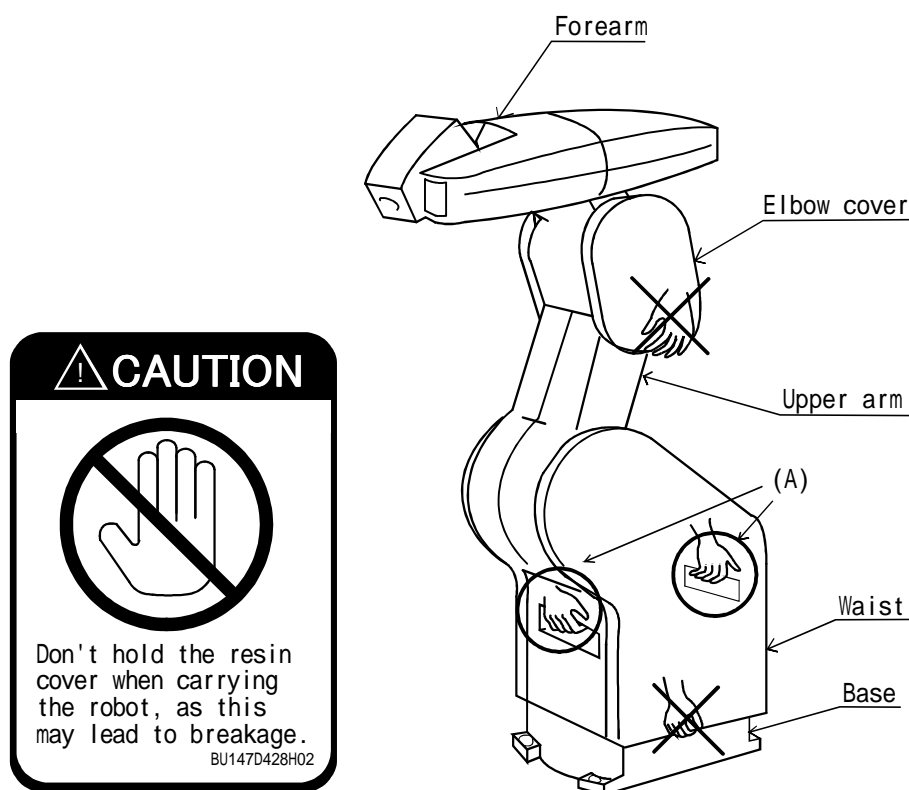

Note) The figure shows the 6-axis type, but this also applies for the 5-axis type.

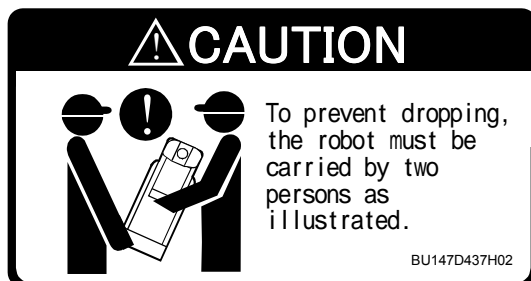

5-axis type

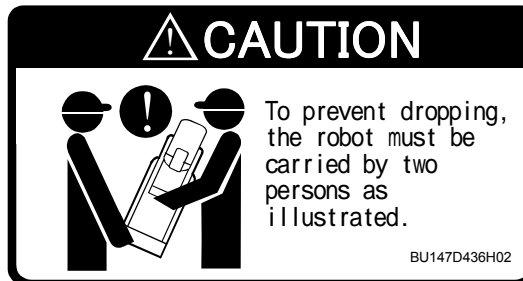

6-axis type

Fig.2-2 : Transportation of robot arm

- 1) When transporting with the grips, one worker should hold the grip (A) at the waist, and support the arm from the side with his body. Lifting the sides of the robot or its covers that don't have any grips can be the cause of accidents, such as the robot falling over, damage to the cover, or the dropping of the cover. Therefore it should never be attempted.
- 2) Make sure you do not apply any pressure to the covers when transporting the robot arm. To prevent accidents, You should not move any axis that does not have a brake.
(6-axis type: J4, J6 axes, 5-axis type: J6 axis)
- 3) When transporting the robot, use a cart. Carrying the robot arm by its grips should be limited to putting it on a cart or stand or to reposition it.
- 4) When transporting the robot arm, use an assistant, and make it a 2-person job.
- 5) Avoid applying any shock to the robot arm when transporting it.

**CAUTION**

To prevent accidents, do not hold the robot from the left/right sides, or hold covers that have no grips.

2.2.3 Installation procedures

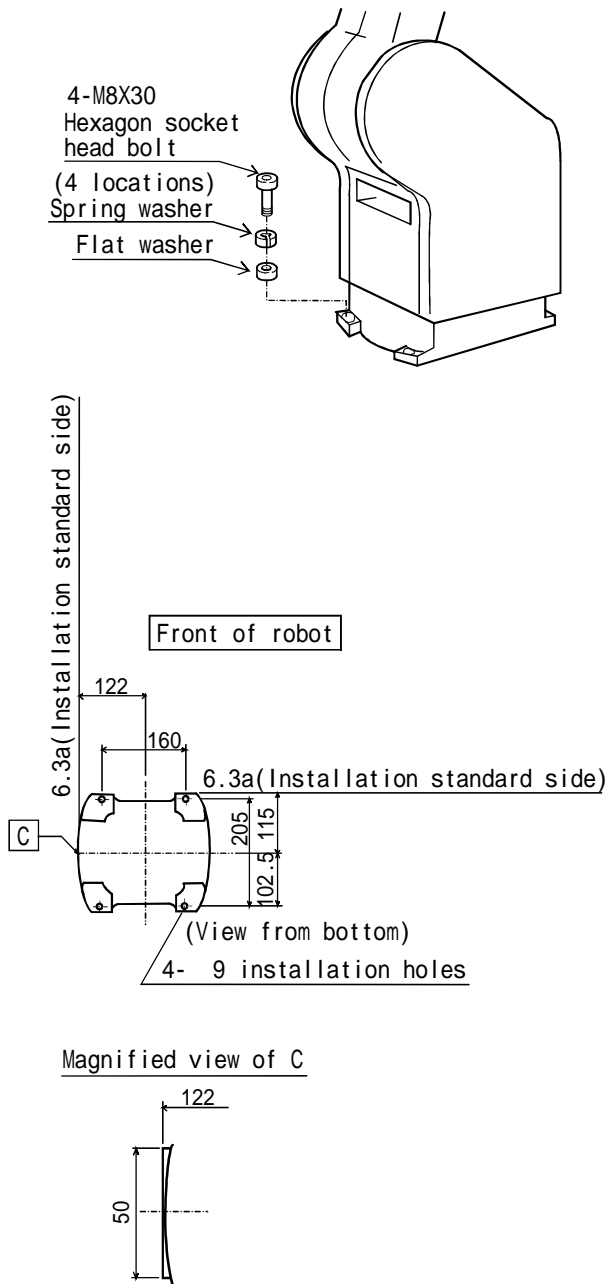

Fig.2-3 : Installation dimensions

- 1) The robot installation surface has been machine finished. Use the installation holes (4- $\phi 9$ holes) opened at the four corners of the base, and securely fix the robot with the enclosed installation bolts (M8 x 30 hexagon socket bolts).
- 2) Install the robot on a level surface.
- 3) It is recommended that the surface roughness of the table onto which the robot is to be installed by 6.3a or more. If the installation surface is rough, the contact with the table will be poor, and positional deviation could occur when the robot moves.
- 4) When installing, use a common table to prevent the position of the devices and jigs subject to robot work from deviating.
- 5) The installation surface must have sufficient strength to withstand the arm reaction during operation, and resistance against deformation and vibration caused by the static (dynamic) load of the robot arm and peripheral devices, etc.

2.2.4 Grounding procedures

(1) Grounding methods

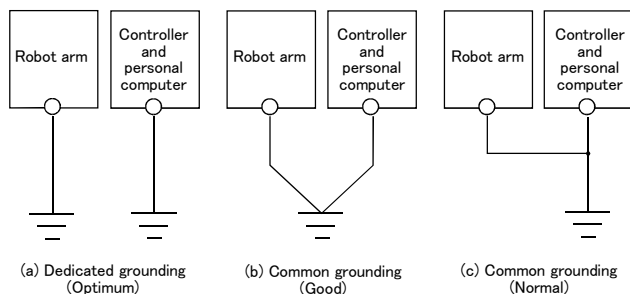

Fig.2-4 : Grounding methods

(2) Grounding procedures

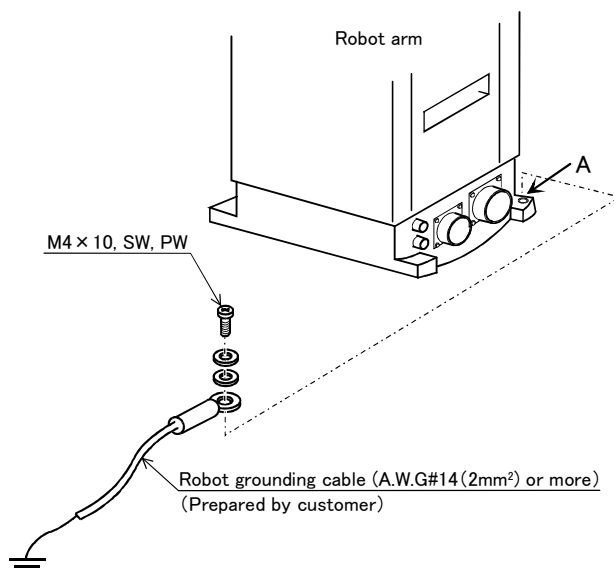

Fig.2-5 : Connecting the grounding cable

- 1) There are three grounding methods as shown in Fig. 2-4, but the dedicated grounding (Fig. 2-4 (a)) should be used for the robot arm and controller when possible. (Refer to the separate "Controller Setup, Basic Operation and Maintenance" for details on the controller grounding.)
- 2) Use Class D grounding (grounding resistance 100Ω or less).
Dedicated grounding separated from the other devices should be used.
- 3) Use a AWG#14(2mm²) or more stranded wire for the grounding wire. The grounding point should be as close to the robot arm and controller as possible, and the length of the grounding wire should be short.

- 1) Prepare the grounding cable (AWG#14(2mm²) or more) and robot side installation screw and washer.
- 2) If there is rust or paint on the grounding screw section (A), remove it with a file, etc.
- 3) Connect the grounding cable to the grounding screw section.

2.2.5 Connecting with the controller

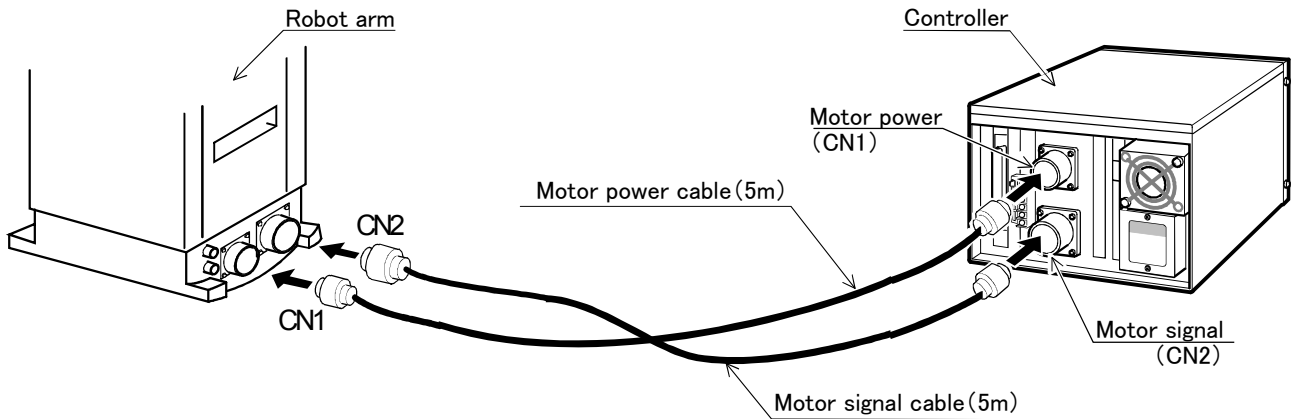

Fig.2-6 : Connecting the machine cables

Carry out the following procedure after installing the controller referring to the separate “Controller Setup, Basic Operation and Maintenance” manual.

- 1) Make sure that the power switch on the front of the controller is turned OFF.
- 2) Connect the machine cable to the robot arm and the corresponding connector on the controller



CAUTION

The machine cable connectors are dedicated for the controller side and robot arm side, so take special care when connecting. If connected incorrectly, the connector pins could bend or break. Thus, even if connected correctly, the robot will not operate correctly, creating a dangerous situation.



CAUTION

Take special care to the leading of the connection cable. If the cable is pulled with force or bent excessively, wires could break or the connector could be damaged.

2.3 Setting the origin

The origin is set so that the robot can be used with a high accuracy. After purchasing the robot, always carry out this step before starting work. This step must also be carried out if the combination of robot and controller being used is changed.

There are several methods for setting the origin, but the origin data input method will be explained here. Refer to [“5.5 Resetting the origin” on page 66](#) for the other methods.

The teaching pendant is required for this operation.

2.3.1 Installing the teaching pendant (T/B)

By using the “REMOVE T/B” switch, the T/B can be installed and removed while the controller’s control power is ON. However, in this procedure, the teaching pendant will be installed with the control power OFF.

Refer to the separate “Controller setup, basic operation, and maintenance” for details on installing the teaching pendant with the control power ON.

(1) Installing with the control power OFF

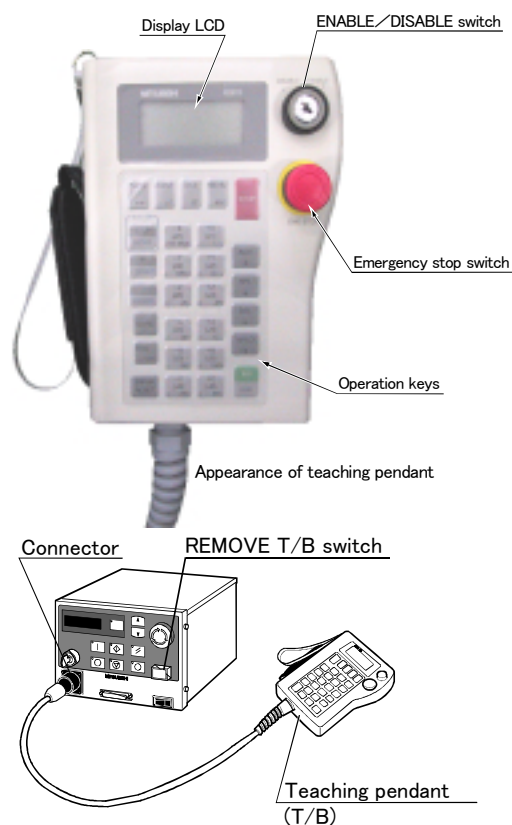

- 1) Confirm that the controller’s power supply switch is OFF.
- 2) Connect the T/B connector to the RS-422 (T/B) connector on the controller.
- 3) Do not pull the cable with force or bend it excessively, as the cable could break or the connector could be damaged.
- 4) Confirm that the [REMOVE T/B] switch on the side of the controller is not depressed (is projected).
- 5) Set the T/B [ENABLE/DISABLE] switch to “DISABLE”.

Fig.2-7 : Installing the T/B (control power OFF)

◆◆◆ [REMOVE T/B] switch ◆◆◆

When using the robot with the T/B, this switch is used to invalidate the emergency stop from the T/B. This is also used to install the T/B with turning the controller’s power supply ON.

2.3.2 Setting the origin with the origin data input method

(1) Confirming the origin data

● Origin data history table (Origin Data History) Serial No.ES804008

Date	Default
D	V!#S29			
J 1	06DTYY			
J 2	2?HL9X			
J 3	1CP55V			
J 4	T6!M\$Y			
J 5	Z2IJ%Z0			
J 6	A12%Z0			
Method	E	E · N · S P	E · N · S P	E · N · S P

(O: AlphabetO, 0: Zero)
 (Note) Meanings of symbols in method column
 E: Jig method
 N: Not used
 SP: Not used

The origin data to be input is noted in the origin data sheet enclosed with the arm, or on the origin data history table attached to the back side of the shoulder cover (B). (Refer to Fig. 2-8).

Referring to “5.3.2 Installing/removing the cover” on page 48, remove the shoulder cover (B), and confirm the value.

The value given in the default setting column is the origin settings set with the calibration jig before shipment. Note that the 5-axis type does not have the J4 axis.

Fig.2-8 : Origin data label (an example)



WARNING

Always install/remove the cover with the controller control power turned OFF. Failure to do so could lead to physical damage or personal injury should the robot start moving due to incorrect operations.

(2) Turning ON the control power



CAUTION

Confirm that there are no operators near the robot before turning the power ON.

- 1) Turn the controller [POWER] switch ON.

The control power will be turned ON, and “ □ . 100 ” will appear on the STATUS NUMBER display on the front of the controller.

(3) Preparing the T/B

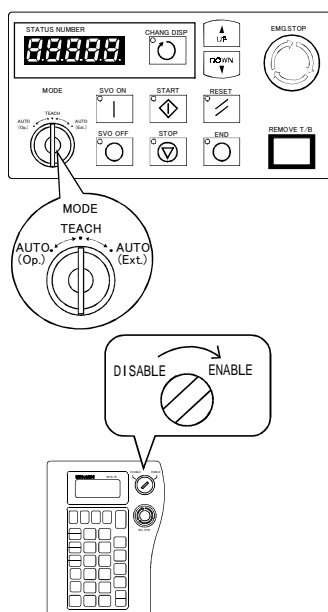

Next, prepare to use the T/B

1) Set the [MODE] switch on the front of the controller to "TEACH".

2) Set the T/B [ENABLE/DISABLE] switch to "ENABLE". The menu selection screen will appear.

The following operations are carried out with the T/B.

◆◆◆ Operating from the T/B ◆◆◆

Always set the [MODE] switch (mode selection key switch) on the front of the controller to "TEACH", and then set the T/B [ENABLE/DISABLE] switch to "ENABLE".

When the T/B is valid, only operations from the T/B are possible. Operations from the controller or external signals will not be accepted.

◆◆◆ When T/B operations are mistaken ◆◆◆

The displayed screen will return to the "menu selection screen" when the [MENU] key is pressed. Carry out the operations again from this screen. Operations can also be carried out again by setting the T/B [ENABLE/DISABLE] switch to "DISABLE" once and then setting to "ENABLE".

(4) Selecting the origin setting method

<T/B screen> [Keys used]

<MENU>
 1.TEACH 2.RUN
 3.FILE 4.MONI
 5.MAINT 6.SET

+C
 (J6)
 5 STU

1) Press the [5] key on the menu screen, and display the maintenance screen.

<MAINT>
 1.PARAM 2.INIT
 3.BRAKE 4.ORIGIN
 5.POWER

-Y
 (J2)
 4 MNO

2) Press the [4] key on the maintenance screen, and display the origin setting method selection screen.

<ORIGIN>
 1.DATA 2.MECH
 3.JIG 4.ABS
 5.USER

-B (J5) INP
 1 DEF EXE

3) Press the [1] key on the origin setting method selection screen, and select the data input method.
 The origin data input method will be selected, and the screen for turning OFF the servo power will appear.

<ORIGIN>
 SERVO OFF
 OK?() █
 █ 1:EXECUTE █

-B (J5) INP
 1 DEF EXE

4) Press the [1] and [INP] keys to turn OFF the servo power. The screen for inputting the origin data will appear.

<DATA>D(000000)
 1:000000 000000
 3:000000 000000
 5:000000 000000

◆◆◆ Selecting a menu ◆◆◆

The menu can be selected with one of the following methods.

A: Press the numeral key for the No. of the item to be selected.

B: Using the [↓] and [↑] keys, etc., move the cursor to the item to be selected, and then press the [INP] key.

(5) Inputting the origin data

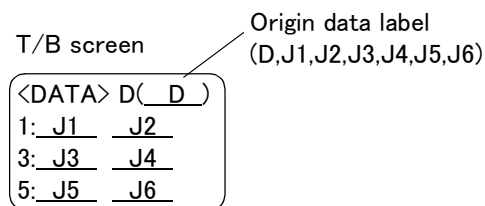

Input the value confirmed in section "(1) Confirming the origin data" on page 12.

The correspondence of the origin data label value and axis to be input is shown in Fig. 2-9. (For the 5-axis robot, the J4 axis is meaningless.)

Fig.2-9 : Correspondence of origin data label and axis

The method for inputting the origin data is explained below. The value shown in Fig. 2-8 will be input as an example.

<T/B screen>	[Keys used]	
<pre> <DATA>D(000000) 1:000000 000000 3:000000 000000 5:000000 000000 </pre>		1) Confirm that the cursor is at the "D" position on the T/B display screen.
<pre> <DATA>D(V00000) 1:000000 000000 3:000000 000000 5:000000 000000 </pre>		2) Input the D value V!%S29. Inputting "V" Press the [VWX] key once while holding down the [CHAR] key. "V" will appear, so release the [CHAR] key. "V" will be set.
<pre> <DATA>D(V!0000) 1:000000 000000 3:000000 000000 5:000000 000000 </pre>		Inputting "!" Press the [#!] key three times while holding down the [CHAR] key. "!" will appear, so release the [CHAR] key. "!" will be set.
<pre> <DATA>D(V!0000) 1:000000 000000 3:000000 000000 5:000000 000000 </pre>		In the same manner, while holding down the [CHAR] key, press the [%" key twice, and the [STU] key once (input "S"). Release the [CHAR] key, and press the [2] key (input "2") and then the [9] key (input "9"). V!%S29 will appear at the "D" data on the teaching pendant screen.
<pre> <DATA>D(V!%S29) 1:000000 000000 3:000000 000000 5:000000 000000 </pre>		3) Press the [↓] key, and move the cursor to the J1 input position. 4) Input the J1 value in the same manner as above.
<pre> <DATA>D(V!%S29) 1:A@B&8F G#\$Y5# 3:H+7%2H B="!1L 5:59A37! K8#&6P </pre>		5) Input the J2, J3, J4, J5 and J6 values in the same manner. Note that the J4 axis is not required for the 5-axis type.
<pre> <DATA>D(V!%S29) CHANGES TO ORIGIN OK? () EXECUTE </pre>		6) After inputting all of the values, press the [INP] key. The origin setting confirmation screen will appear.
		7) Press [1] (-B/-P) and [INP] key to end the origin setting

◇◆◇ Moving the cursor ◇◆◇

Press the [↑], [↓], [←] and [→] keys.

◇◆◇ Inputting characters ◇◆◇

Hold down the [CHAR] key and press the key with the character to be input on the lower right. Three characters will scroll each time the character key is pressed.

◇◆◇ Correcting an input ◇◆◇

After returning one character by pressing the [DEL] key, input the character again.

(6) Installing the shoulder cover (B)

Return the shoulder cover (B), removed in section [“\(1\) Confirming the origin data” on page 12](#) to its original position.

This completes the setting of the origin with the origin data input method.



WARNING

Always remove and install the cover with the controller power turned OFF. Failure to do so could lead to the robot moving because of incorrect operations, or to physical damage or personal injury.

◇◆◇ If the origin input data is incorrect ◇◆◇

If the origin input data is incorrect, the alarm No. 1760 (origin setting data illegal) will occur when origin data input. In this case, reconfirm the value input for the origin data.

2.4 Confirming the operation

In this section, the robot will be moved manually using the T/B to confirm that the operation is correct. Moving the robot manually is called "jog operation". This operation includes the JOINT jog that moves each axis, the XYZ jog that moves along the base coordinate system, the TOOL jog that moves along the tool coordinate system, and the CYLINDER jog that moves along the circular arc.

This operation is carried out while pressing the deadman switch on the back of the T/B.

⚠ CAUTION The robot will move during this operation. Make sure that there are no operators near the robot, and that there are no obstacles, such as tools, in the robot operation range.

⚠ CAUTION To immediately stop the robot, release the deadman switch on the back of the T/B. The servo power will turn OFF, and the robot will stop. The robot will also stop if the [EMG.STOP] switch (emergency stop switch) on the front of the T/B or the [EMG.STOP] switch (emergency stop) on the front of the controller is pressed.

⚠ CAUTION Confirm that the origin has been set. If the origin has not been set, "****" will appear at the current position display on the teaching pendant, the JOINT jog operation will take place in any jog mode selected.

Refer to "2.3 Setting the origin" on page 11 for details on setting the origin.

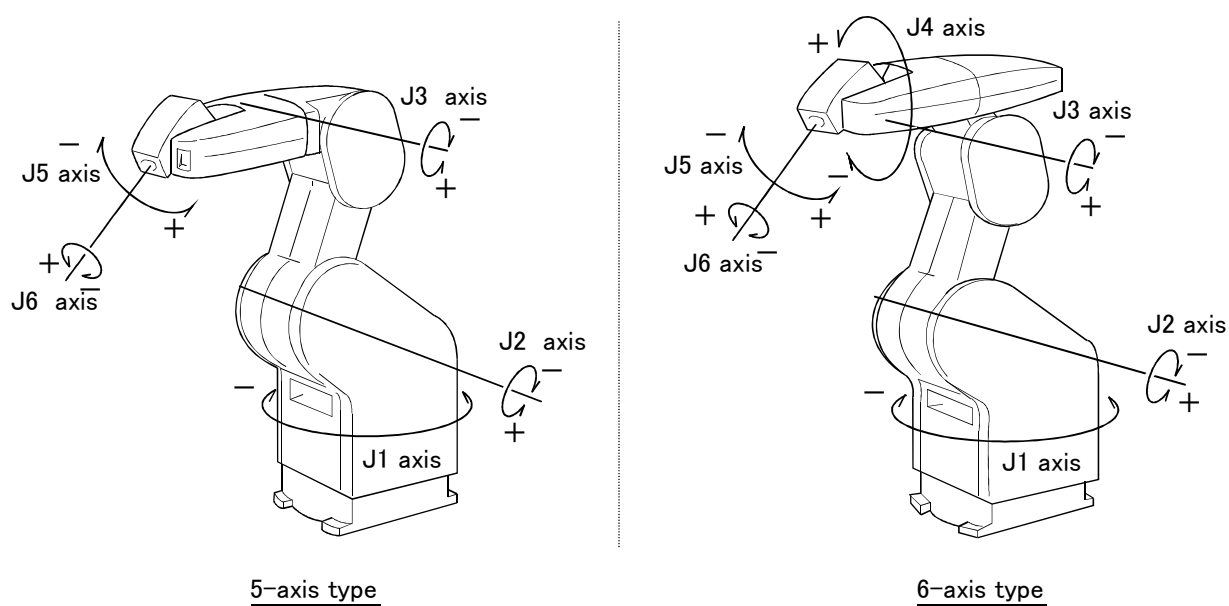

* Each axis moves independently.
The 5-axis type does not have the J4 axis.

Fig.2-10 : JOINT jog operation

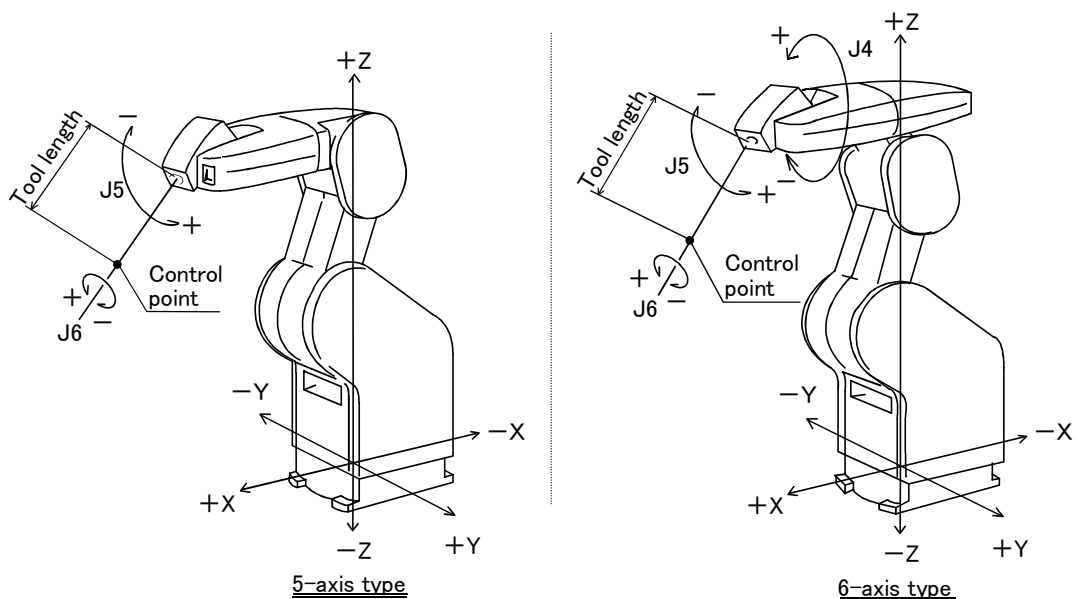

* The axis moves straight along the base coordinate system. At this time, the flange surface posture is not maintained.
 Also, the flange surface posture changes. The flange surface position changes at this time.

Fig.2-13 : 3-axis XYZ jog operation

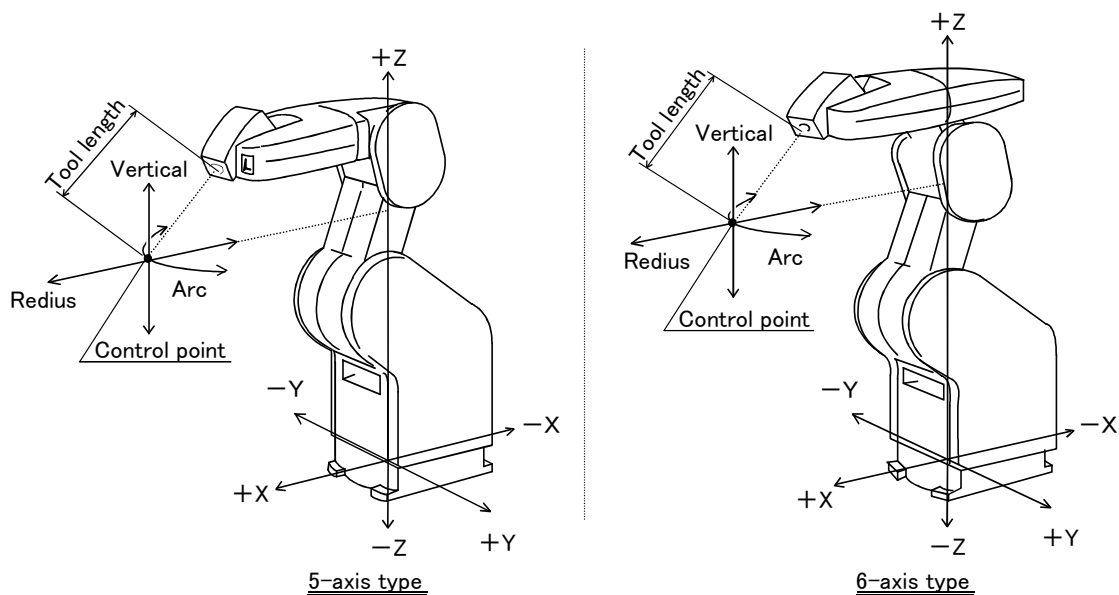

* The current position is set as the arc centering on the Z axis, and the axis moves along that arc, expands and contracts in the radius direction, and moves vertically. At this time, for the 6-axis type, the flange surface posture is maintained. Also, while maintaining the flange surface position, the flange surface posture changes.

Fig.2-14 : CYLINDER jog operation

(1) JOINT jog operation

Select the JOINT jog mode

JOINT	LOW
J1	+34.50
J2	+20.00
J3	+80.00

JOINT jog mode

STEP
MOVE

 +

JOINT
()?

Press the [MOVE] + [JOINT] keys to select the JOINT jog mode. "JOINT" will appear at the upper left of the screen.

Set the jog speed

JOINT	LOW
J1	+34.50
J2	+20.00
J3	+80.00

Set the speed

STEP
MOVE

 +

+

FORWD

-

BACKWD

Each time the [MOVE] + [+] keys are pressed, the override will increase in the order of LOW → HIGH → 3 → 5 → 10 → 30 → 50 → 70 → 100%.

When the [MOVE] + [-] keys are pressed, the override will decrease in the reverse order. The currently set speed will appear on the upper right of the screen.

Set the override to 10% here for confirmation work.

J1 axis jog operation

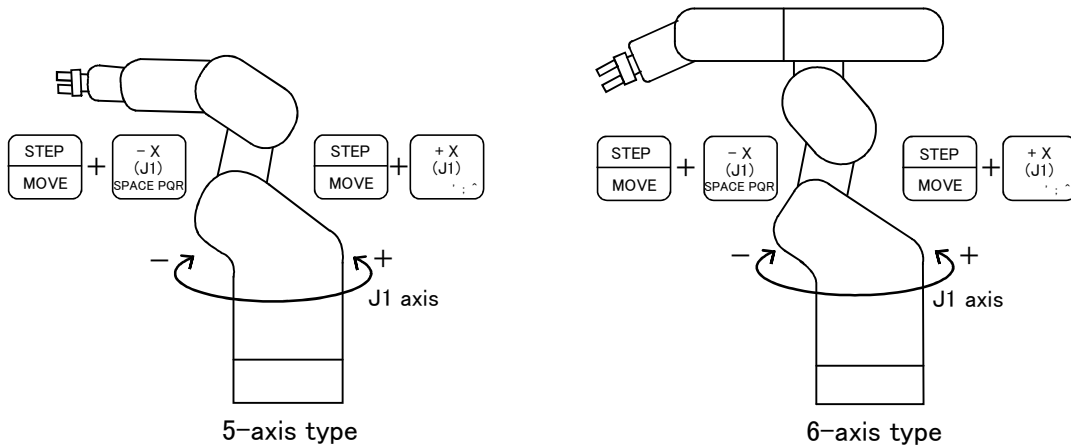

- When the [MOVE] + [+X (J1)] keys are pressed, the J1 axis will rotate in the plus direction. When the [MOVE] + [-X (J1)] keys are pressed, Rotate in the minus direction.

J2 axis jog operation

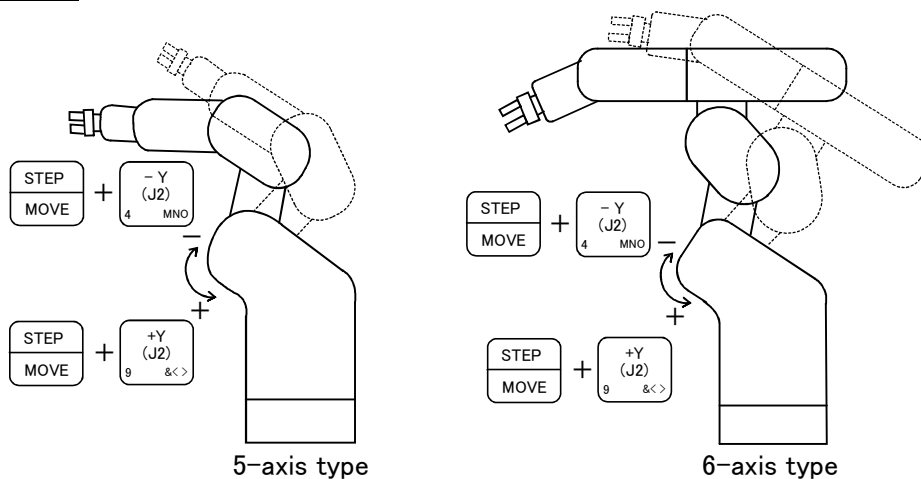

- When the [MOVE] + [+Y (J2)] keys are pressed, the J2 axis will rotate in the plus direction. When the [MOVE] + [-Y (J2)] keys are pressed, Rotate in the minus direction.

◆◆◆ When the robot is in the transportation posture ◆◆◆
 The axes may be outside the movement area. Move these axes toward the inner side of the movement area. If moved outward, an will appear on the T/B screen, and the robot will not move.

J3 axis jog operation

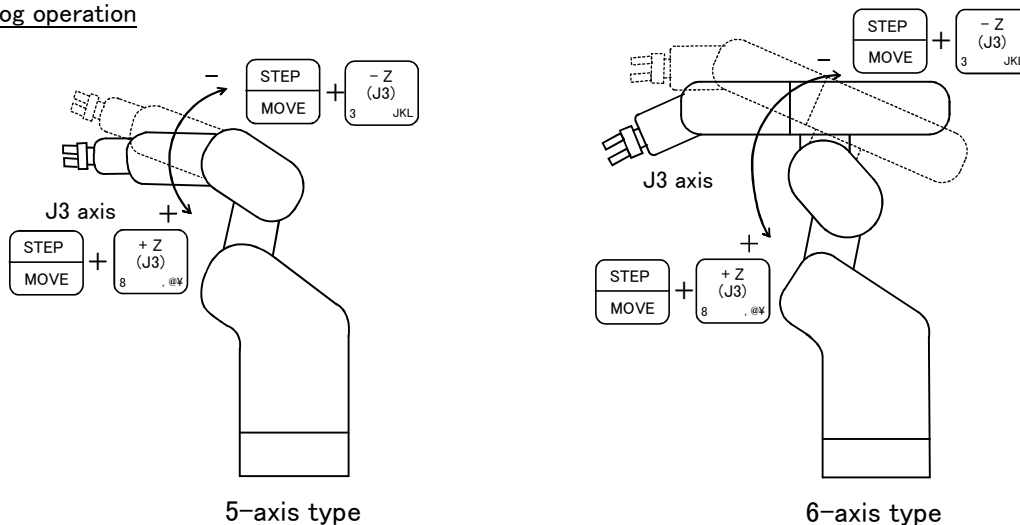

- When the [MOVE] + [+Z (J3)] keys are pressed, the J3 axis will rotate in the plus direction. When the [MOVE] + [-Z (J3)] keys are pressed, Rotate in the minus direction.

J4, J5 and J6 axis jog operation

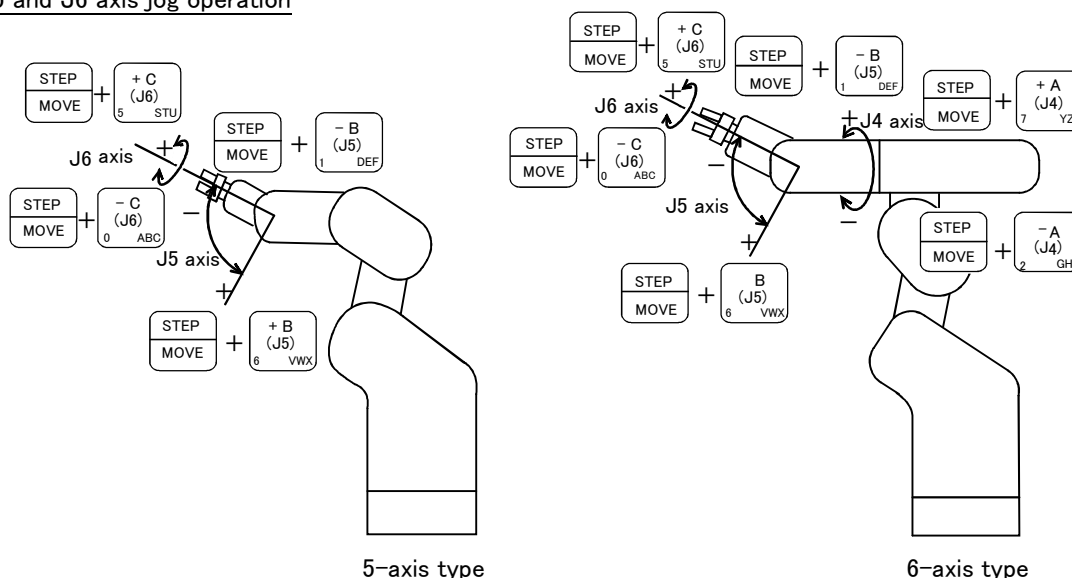

- When the [MOVE] + [+A (J4)] keys are pressed, the J4 axis will rotate in the plus direction. When the [MOVE] + [-A (J4)] keys are pressed, Rotate in the minus direction. (6-axis type only)
- When the [MOVE] + [+B (J5)] keys are pressed, the J5 axis will rotate in the plus direction. When the [MOVE] + [-B (J5)] keys are pressed, Rotate in the minus direction.
- When the [MOVE] + [+C (J6)] keys are pressed, the J6 axis will rotate in the plus direction. When the [MOVE] + [-C (J6)] keys are pressed, Rotate in the minus direction.

◆◆◆ When an appears on the T/B screen display ◆◆◆

If the robot is moved outside the movement area, an will appear. In this case, move the axis in the opposite direction.

JOINT	LOW
<input checked="" type="checkbox"/> J1	+160.00
J2	+20.00
J3	+80.00

In the example on the left, the J1 axis is at the limit of the plus side movement area.

(2) XYZ jog operation

Select the XYZ jog mode

X,Y,Z	LOW
X	+134.50
Y	+220.00
Z	+280.00

XYZ jog mode

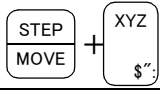

Press the [MOVE] + [XYZ] keys to select the XYZ jog mode. "XYZ" will appear at the upper left of the screen.

Set the jog speed

X,Y,Z	LOW
X	+134.50
Y	+220.00
Z	+280.00

Set the speed

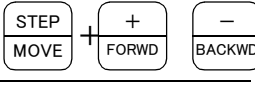

Each time the [MOVE] + [+] keys are pressed, the override will increase in the order of LOW → HIGH → 3 → 5 → 10 → 30 → 50 → 70 → 100%. When the [MOVE] + [-] keys are pressed, the override will decrease in the reverse order. The currently set speed will appear on the upper right of the screen. Set the override to 10% here for confirmation work.

Moving along the base coordinate system

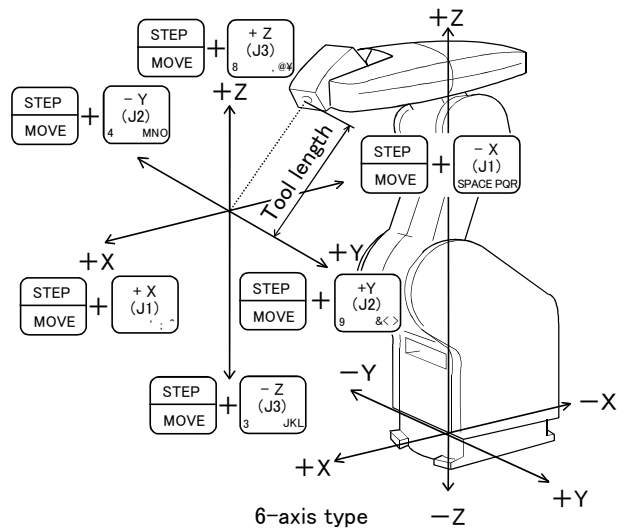
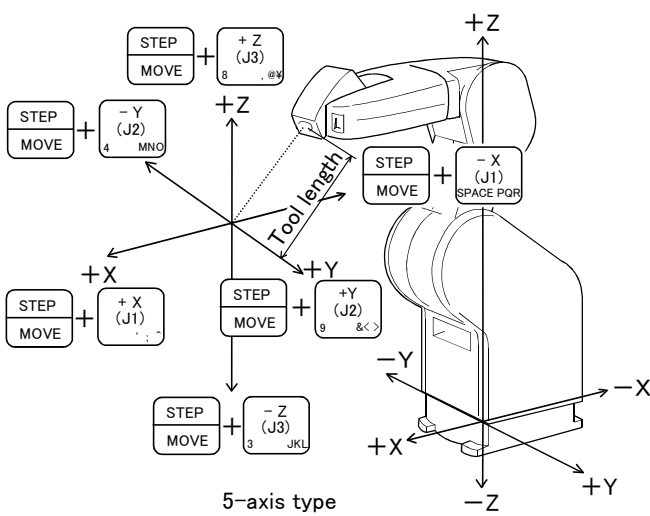

※ The direction of the frange will not change

- When the [MOVE] + [+X (J1)] keys are pressed, the robot will move along the X axis plus direction. When the [MOVE] + [-X (J1)] keys are pressed, Move along the minus direction.
- When the [MOVE] + [+Y (J2)] keys are pressed, the robot will move along the Y axis plus direction. When the [MOVE] + [-Y (J2)] keys are pressed, Move along the minus direction.
- When the [MOVE] + [+Z (J3)] keys are pressed, the robot will move along the Z axis plus direction. When the [MOVE] + [-Z (J3)] keys are pressed, Move along the minus direction.

◆◆◆ When the robot is in the transportation posture ◆◆◆

There are directions from which linear movement is not possible from the transportation posture. In this case, an will appear on the T/B screen, and the robot will not move. Refer to section "(1) JOINT jog operation" on page 20", and move the robot to a position where linear movement is possible, and then carry out XYZ jog.

◆◆◆ When an appears on the T/B screen display ◆◆◆

If the robot is moved outside the movement area with any of the axes, an will appear. In this case, move the axis in the opposite direction.

XYZ	LOW
<input checked="" type="checkbox"/> X	+360.00
<input checked="" type="checkbox"/> Y	+280.00
<input checked="" type="checkbox"/> Z	+170.00

In the example on the left, further linear movement in the same direction is not possible.

Changing the flange surface posture

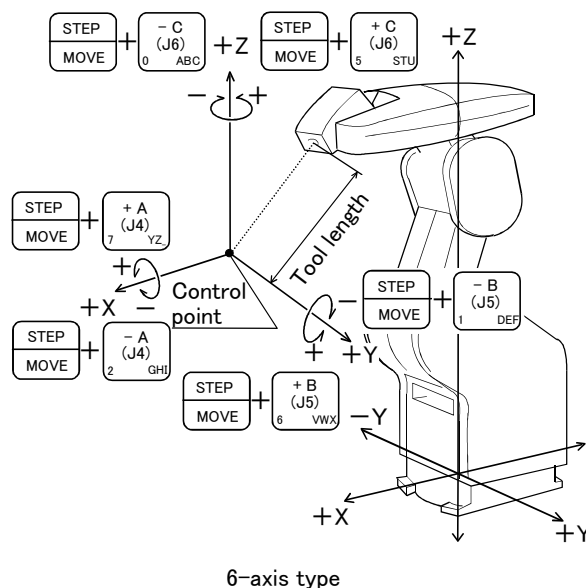
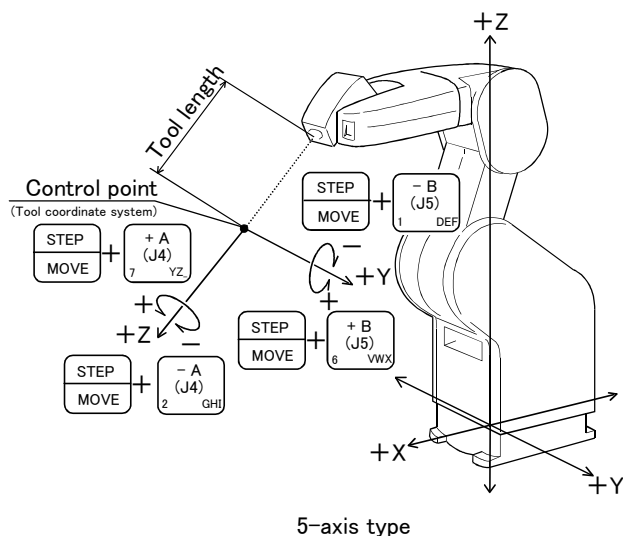

* The control point does not change.

- When the [MOVE] + [+A (J4)] keys are pressed,
 - 6-axis type: The X axis will rotate in the plus direction.
 - 5-axis type: The Z axis will rotate in the plus direction of the tool coordinate system.
- When the [MOVE] + [-A (J4)] keys are pressed, Rotate in the minus direction.
- When the [MOVE] + [+B (J5)] keys are pressed,
 - 6-axis type: The Y axis will rotate in the plus direction.
 - 5-axis type: The Y axis will rotate in the plus direction of the tool coordinate system.
- When the [MOVE] + [-B (J5)] keys are pressed, Rotate in the minus direction.
- When the [MOVE] + [+C (J6)] keys are pressed,
 - 6-axis type: The Z axis will rotate in the plus direction.
 - 5-axis type: There is no operation.
- When the [MOVE] + [-C (J6)] keys are pressed,
 - 6-axis type: Rotate in the minus direction.
 - 5-axis type: There is no operation.

◆◆◆ When alarm No. 5150 occurs ◆◆◆

If alarm No. 5150 (ORIGIN NOT SET) occurs, the origin has not been set correctly. Reconfirm the value input for the origin data.

◆◆◆ Tool length ◆◆◆

The default tool length is 0mm, and the control point is the center of the end axis.

After installing the hand, set the correct tool length in the parameters. Refer to the separate manual "Detailed Explanation of Functions and Operations" for details.

(3) TOOL jog operation

Select the TOOL jog mode



Set the jog speed

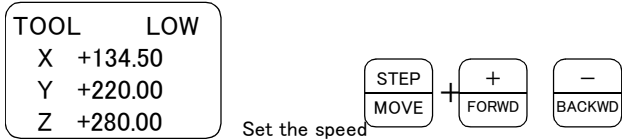

Press the [MOVE] + [TOOL] keys to select the TOOL jog mode. "TOOL" will appear at the upper left of the screen.

Each time the [MOVE] + [+] keys are pressed, the override will increase in the order of LOW → HIGH → 3 → 5 → 10 → 30 → 50 → 70 → 100%. When the [MOVE] + [-] keys are pressed, the override will decrease in the reverse order. The currently set speed will appear on the upper right of the screen. Set the override to 10% here for confirmation work.

Moving along the tool coordinate system

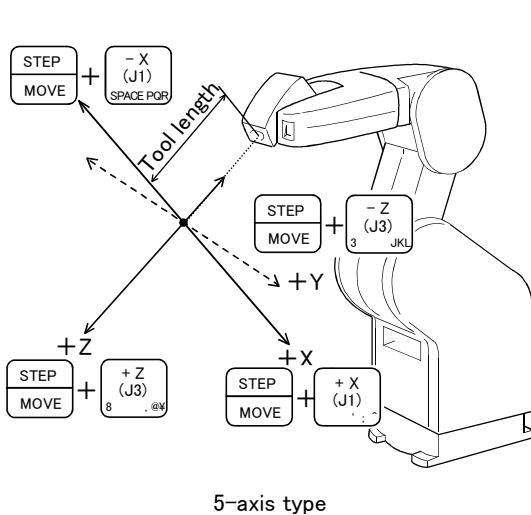

5-axis type

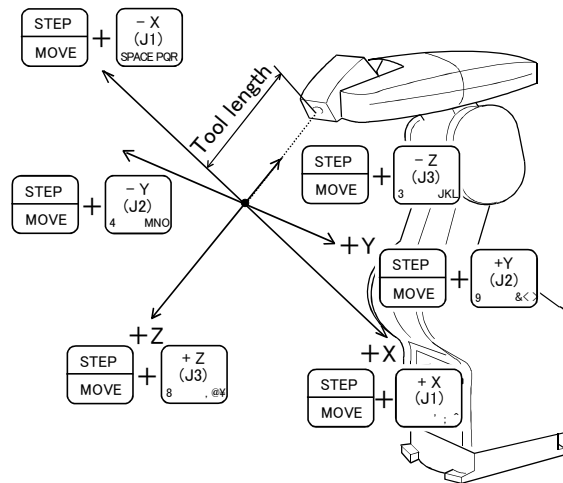

6 axis type

* The direction of the frange will not change.

- When the [MOVE] + [+X (J1)] keys are pressed, the robot will move along the X axis plus direction of the tool coordinate system.
When the [MOVE] + [-X (J1)] keys are pressed, Move along the minus direction.
- When the [MOVE] + [+Y (J2)] keys are pressed, the robot will move along the Y axis plus direction of the tool coordinate system.
When the [MOVE] + [-Y (J2)] keys are pressed, Move along the minus direction. (6-axis type only)
- When the [MOVE] + [+Z (J3)] keys are pressed, the robot will move along the Z axis plus direction of the tool coordinate system.
When the [MOVE] + [-Z (J3)] keys are pressed, Move along the minus direction.

◆◆◆ When the robot is in the transportation posture ◆◆◆

There are directions from which linear movement is not possible from the transportation posture. In this case, an  will appear on the T/B screen, and the robot will not move. Refer to section "(1) JOINT jog operation" on page 20, and move the robot to a position where linear movement is possible, and then carry out TOOL jog.

◆◆◆ When an **X** appears on the T/B screen display ◆◆◆

If the robot is moved outside the movement area with any of the axes, an **X** will appear. In this case, move the axis in the opposite direction.

TOOL	LOW
X X	+360.00
X Y	+280.00
X Z	+170.00

In the example on the left, further linear movement in the same direction is not possible.

Changing the flange surface posture

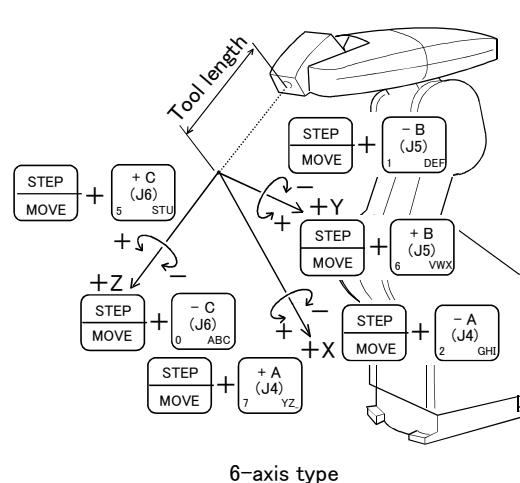
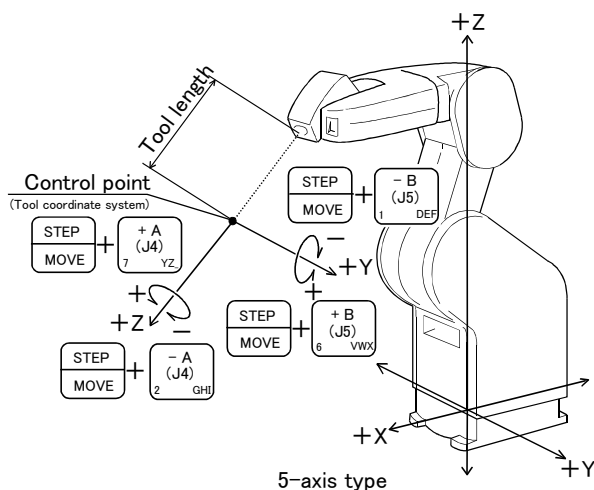

* The control point does not change.

- When the [MOVE] + [+A (J4)] keys are pressed,
 - 6-axis type: The X axis will rotate in the plus direction of the tool coordinate system.
 - 5-axis type: The Z axis will rotate in the plus direction of the tool coordinate system.
- When the [MOVE] + [-A (J4)] keys are pressed,
 - 6-axis type: Rotate in the minus direction.
 - 5-axis type: Rotate in the minus direction.
- When the [MOVE] + [+B (J5)] keys are pressed,
 - 6-axis type: The Y axis will rotate in the plus direction of the tool coordinate system.
 - 5-axis type: The Y axis will rotate in the plus direction of the tool coordinate system.
- When the [MOVE] + [-B (J5)] keys are pressed, Rotate in the minus direction.
- When the [MOVE] + [+C (J6)] keys are pressed,
 - 6-axis type: The Z axis will rotate in the plus direction of the tool coordinate system.
 - 5-axis type: There is no operation.
- When the [MOVE] + [-C (J6)] keys are pressed,
 - 6-axis type: Rotate in the minus direction.
 - 5-axis type: There is no operation.

◆◆◆ When alarm No. 5150 occurs ◆◆◆

If alarm No. 5150 (ORIGIN NOT SET) occurs, the origin has not been set correctly. Reconfirm the value input for the origin data.

◆◆◆ Tool length ◆◆◆

The default tool length is 0mm, and the control point is the center of the end axis.

After installing the hand, set the correct tool length in the parameters. Refer to the separate manual "Detailed Explanation of Functions and Operations" for details.

(4) 3-axis XYZ jog operation

Select the 3-axis XYZ jog mode

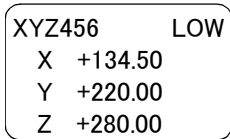

3-axis XYZ jog mode

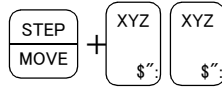

Press the [MOVE] + [XYZ] keys, and then press only the [XYZ] key. "XYZ456" will appear at the upper left of the screen.

Set the jog speed

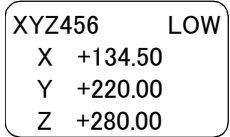

Set the speed

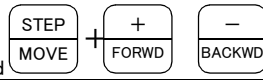

Each time the [MOVE] + [+] keys are pressed, the override will increase in the order of LOW → HIGH → 3 → 5 → 10 → 30 → 50 → 70 → 100%. When the [MOVE] + [-] keys are pressed, the override will decrease in the reverse order. The currently set speed will appear on the upper right of the screen. Set the override to 10% here for confirmation work.

Moving along the base coordinate system

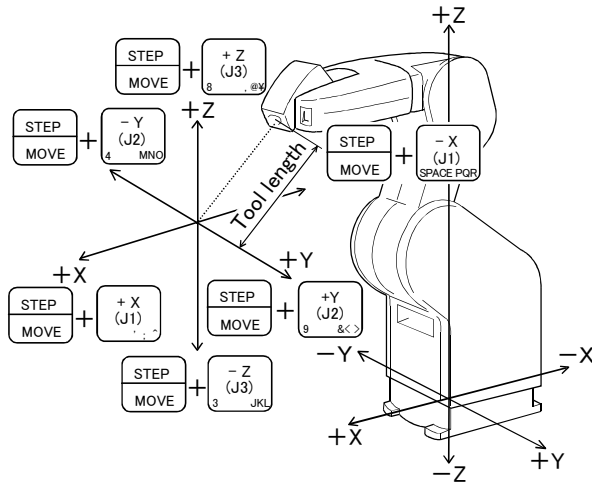

5-axis type

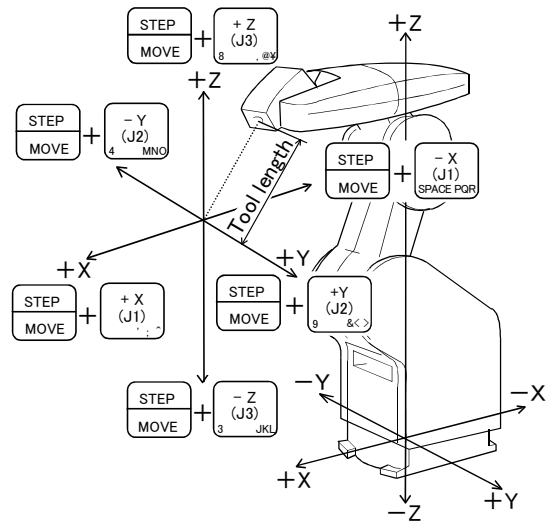

6-axis type

* The flange position does change.

- When the [MOVE] + [+X (J1)] keys are pressed, the robot will move along the X axis plus direction. When the [MOVE] + [-X (J1)] keys are pressed, Move along the minus direction.
- When the [MOVE] + [+Y (J2)] keys are pressed, the robot will move along the Y axis plus direction. When the [MOVE] + [-Y (J2)] keys are pressed, Move along the minus direction.
- When the [MOVE] + [+Z (J3)] keys are pressed, the robot will move along the Z axis plus direction. When the [MOVE] + [-Z (J3)] keys are pressed, Move along the minus direction.

◆◆◆ Jog mode will change when only [XYZ] key is pressed again ◆◆◆

When the [MOVE] + [XYZ] keys are pressed and then only the [XYZ] key is pressed, the upper left display will change in the order of "XYZ" → "XYZ456" → "CYLNDER". Each jog mode can be selected.

◆◆◆ The flange surface end axis posture cannot be maintained with 3-axis XYZ jog. ◆◆◆

With 3-axis XYZ jog, the flange surface end axis posture (orientation) is not maintained when moving linearly in the X, Y or Z axis direction. Use XYZ jog to maintain the posture.

Changing the flange surface posture

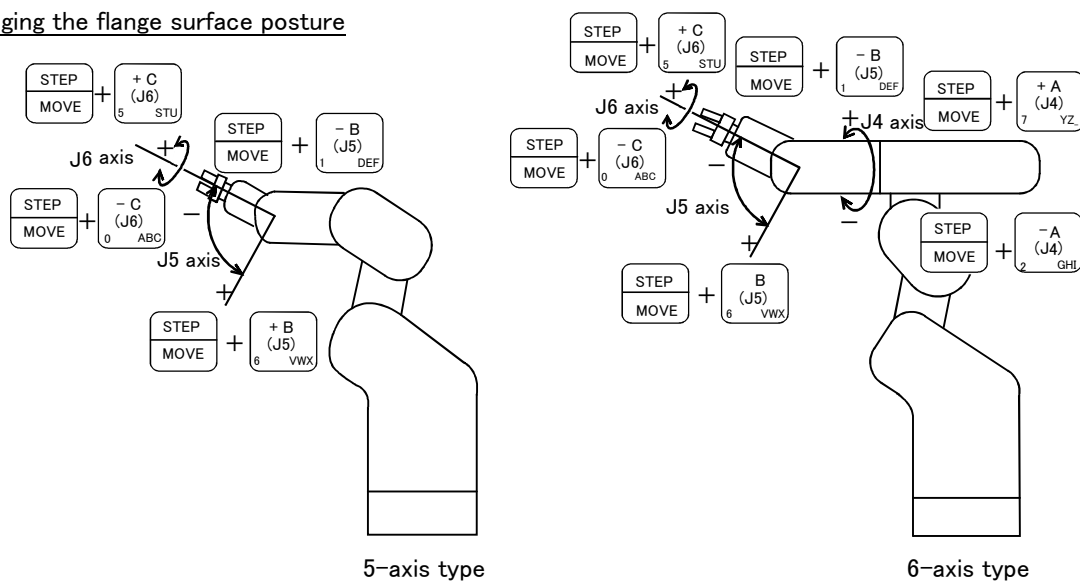

* The flange position changes.
Interpolate the joint, taking care not to change the control point. operation.

- When the [MOVE] + [+A (J4)] keys are pressed, the J4-axis will rotate in the plus direction.
When the [MOVE] + [-A (J4)] keys are pressed, Rotate in the minus direction. (6-axis type only)
- When the [MOVE] + [+B (J5)] keys are pressed, the J5-axis will rotate in the plus direction.
When the [MOVE] + [-B (J5)] keys are pressed, Rotate in the minus direction.
- When the [MOVE] + [+C (J6)] keys are pressed, the J6-axis will rotate in the plus direction.
When the [MOVE] + [-C (J6)] keys are pressed, Rotate in the minus direction.

(5) CYLINDER jog operation

Select the cylindrical jog mode

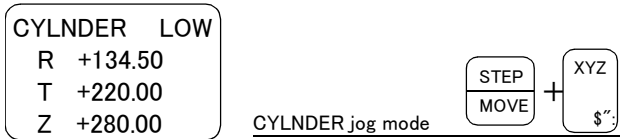

Press the [MOVE] + [XYZ] keys, and then press only the [XYZ] key. "CYLINDER" will appear at the upper left of the screen.

Set the jog speed

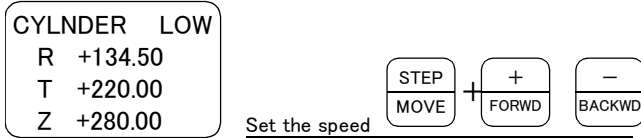

Each time the [MOVE] + [+] keys are pressed, the override will increase in the order of LOW → HIGH → 3 → 5 → 10 → 30 → 50 → 70 → 100%. When the [MOVE] + [-] keys are pressed, the override will decrease in the reverse order. The currently set speed will appear on the upper right of the screen. Set the override to 10% here for confirmation work.

Moving along an arc centering on the Z axis

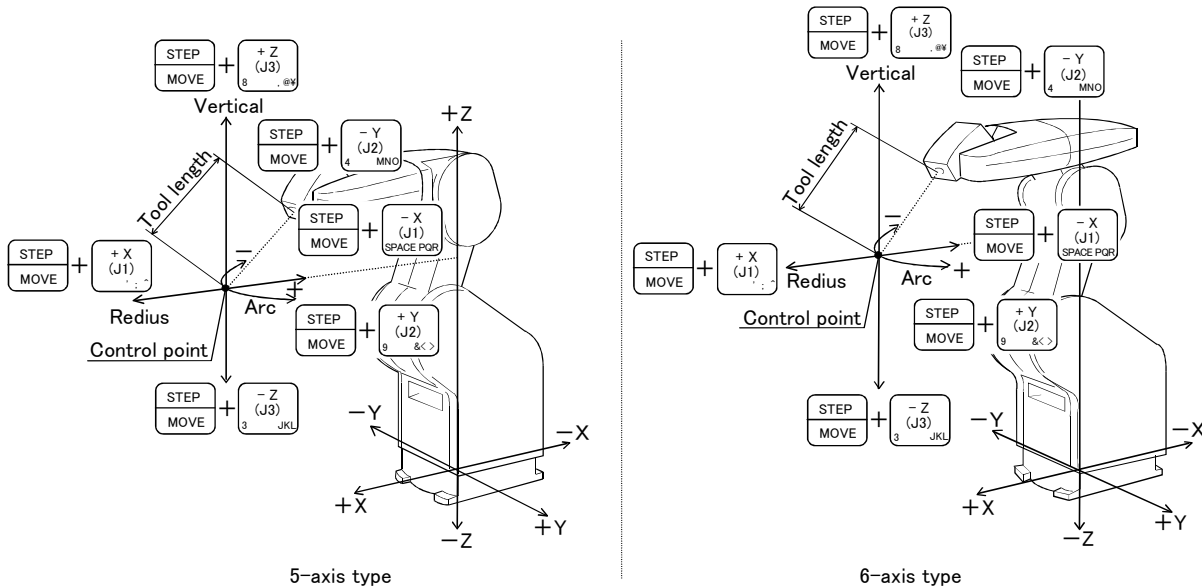

* The direction of the frange will not change.

Assuming that the current position is on an arc centering on the Z axis, the robot moves along that arc.

- When the [MOVE] + [+Y (J2)] keys are pressed, the robot will move along the arc in the plus direction. When the [MOVE] + [-Y (J2)] keys are pressed, Move in the minus direction.
- When the [MOVE] + [+X (J1)] keys are pressed, the robot will expand in the radial direction. When the [MOVE] + [-X (J1)] keys are pressed, Contract in the radial direction.
- When the [MOVE] + [+Z (J3)] keys are pressed, the robot will move along the Z axis plus direction. When the [MOVE] + [-Z (J3)] keys are pressed, Move along the minus direction.

Changing the flange surface posture

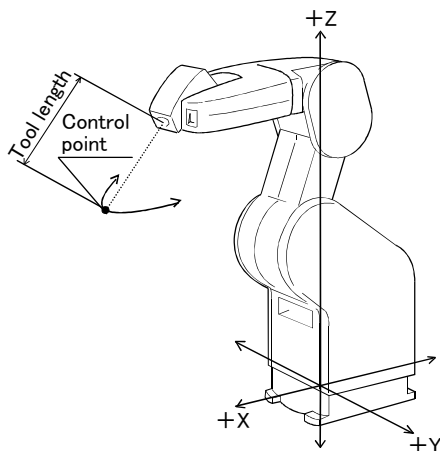

5-axis type

Note) The 5-axis type does not have this movement.

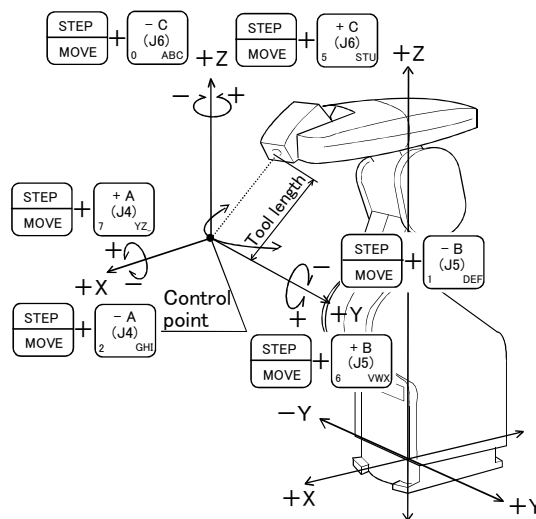

6-axis type

* The flange position does not change. This is the same as the A, B and C axis XYZ jog operation.

- When the [MOVE] + [+A (J4)] keys are pressed,
 - 6-axis type: The X axis will rotate in the plus direction.
 - 5-axis type: There is no operation.
- When the [MOVE] + [-A (J4)] keys are pressed,
 - 6-axis type: Rotates in the minus direction.
 - 5-axis type: There is no operation.

- When the [MOVE] + [+B (J5)] keys are pressed,
 - 6-axis type: The Y axis will rotate in the plus direction.
 - 5-axis type: There is no operation.
- When the [MOVE] + [-B (J5)] keys are pressed,
 - 6-axis type: Rotates in the minus direction.
 - 5-axis type: There is no operation.

- When the [MOVE] + [+C (J6)] keys are pressed,
 - 6-axis type: The Z axis will rotate in the plus direction.
 - 5-axis type: There is no operation.
- When the [MOVE] + [-C (J6)] keys are pressed,
 - 6-axis type: Rotates in the minus direction.
 - 5-axis type: There is no operation.

3 Installing the option devices

3.1 Installing the solenoid valve set(1E-VD01/VD01E/VD02/VD02E)

The following shows how to install the solenoid valve set.

Please note that the installation method differs, depending on the robot arm type. Refer to the item which corresponds to robot type being used.

3.1.1 RV-2A, RV-3AJ (General environment)

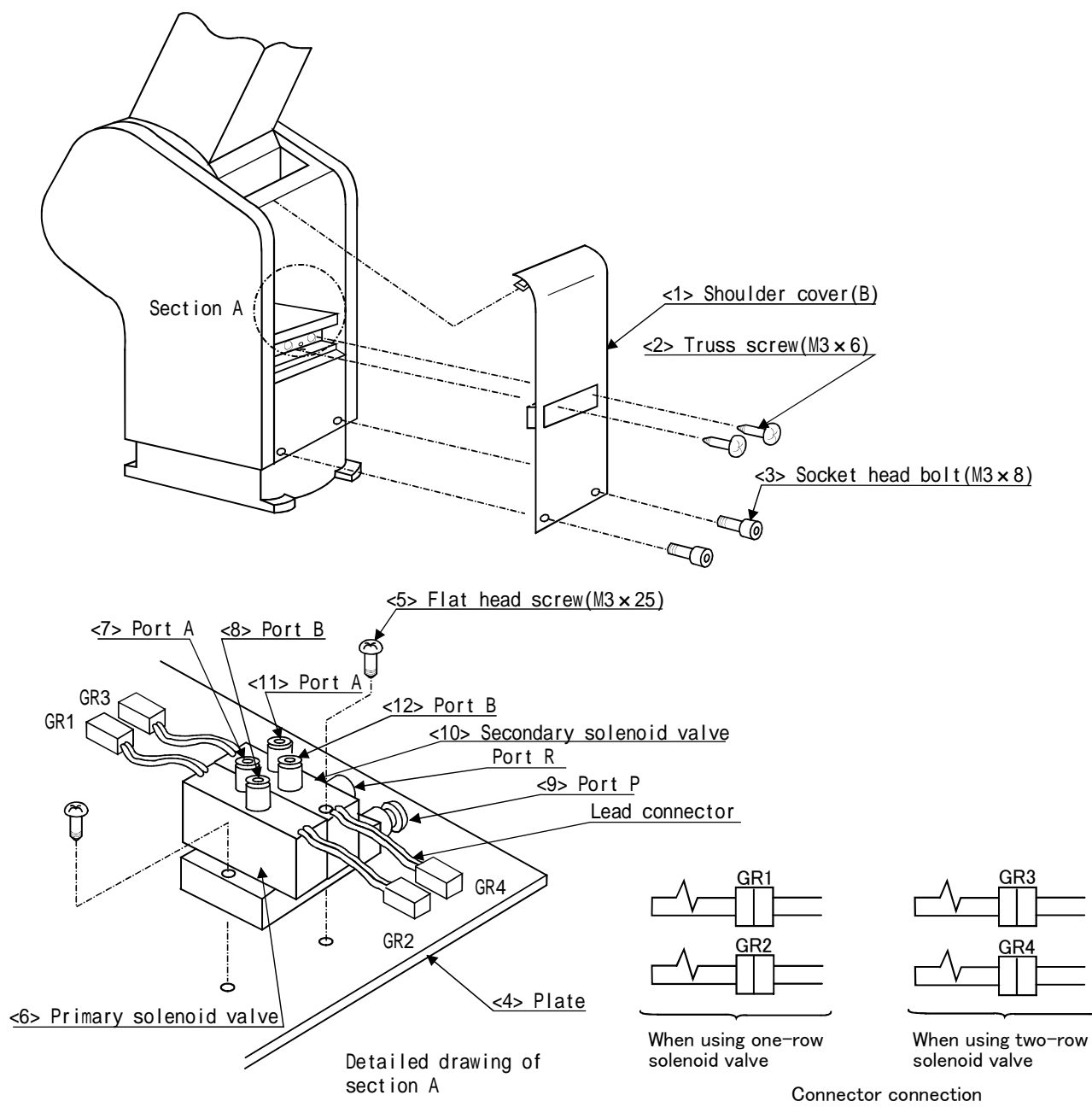

Fig. 3-1 : Solenoid valve installation procedures(RV-2A, RV-3AJ)

Fig. 3-1 shows the solenoid valve installation procedures and the solenoid valve connector connection procedures. The installation procedures are as follow. This work must be carried out with the controller power turned OFF.

- 1) Remove the two (M3x6) screws <2> and the two (M3x8) bolts <3>, and remove the shoulder cover (B) <1>.
- 2) Install the solenoid valve by fastening it with the two attached (M3x25) screws <5> to the screw holes on the plate <4> of the robot arm.

- 3) Connect one of the two ($\phi 6$) pneumatic hoses in section A --the one marked "AIR IN" --to the quick coupling (port P) <9> of the solenoid valve <6>. The primary air flow can now be supplied from the pneumatic port at the base.
- 4) Connect the hose marked "1" to port A <7> on the primary solenoid valve <6>. Connect the hose marked "2" to port B <8> on the primary solenoid valve <6>. If you are using the double type valves (1E-VD02/VD02E), you need to do the following: Connect the hose marked "3" to port A <11> on the secondary solenoid valve <10>. Connect the hose marked "4" to port B <12> on the secondary solenoid valve <10>.
- 5) Connect the GR1 plug protruding from the primary solenoid valve <6> to the connector GR1. Connect the GR2 plug protruding from the primary solenoid valve <6>to the connector GR2. If you are using double type valves (1E-VD02/VD02E), Connect the GR3 plug protruding from the secondary solenoid valve <10> to the connector GR3. Connect the GR4 plug protruding from the secondary solenoid valve <10 >to the connector GR4.
- 6) When you have completed the installation, reinstall the shoulder cover (B) <1> to its original position, and be careful not to entangle the cables when you do so.

The connections after the installation appear as in [Table 3-1](#) for single type valves, hand 2 is not applicable.

Table 3-1 : Solenoid valve ports and hoses: Correspondence of couplings and hand ports

Hand	Hand port	Fore arm coupling No.	Hose number	Solenoid valve port	Solenoid valve used
Hand 1	OPEN	1	1	A	First set
	CLOSE	2	2	B	
Hand 2	OPEN	3	3	A	Second set
	CLOSE	4	4	B	

3.1.2 RV-2AM, RV-3AJM (Protection specification)

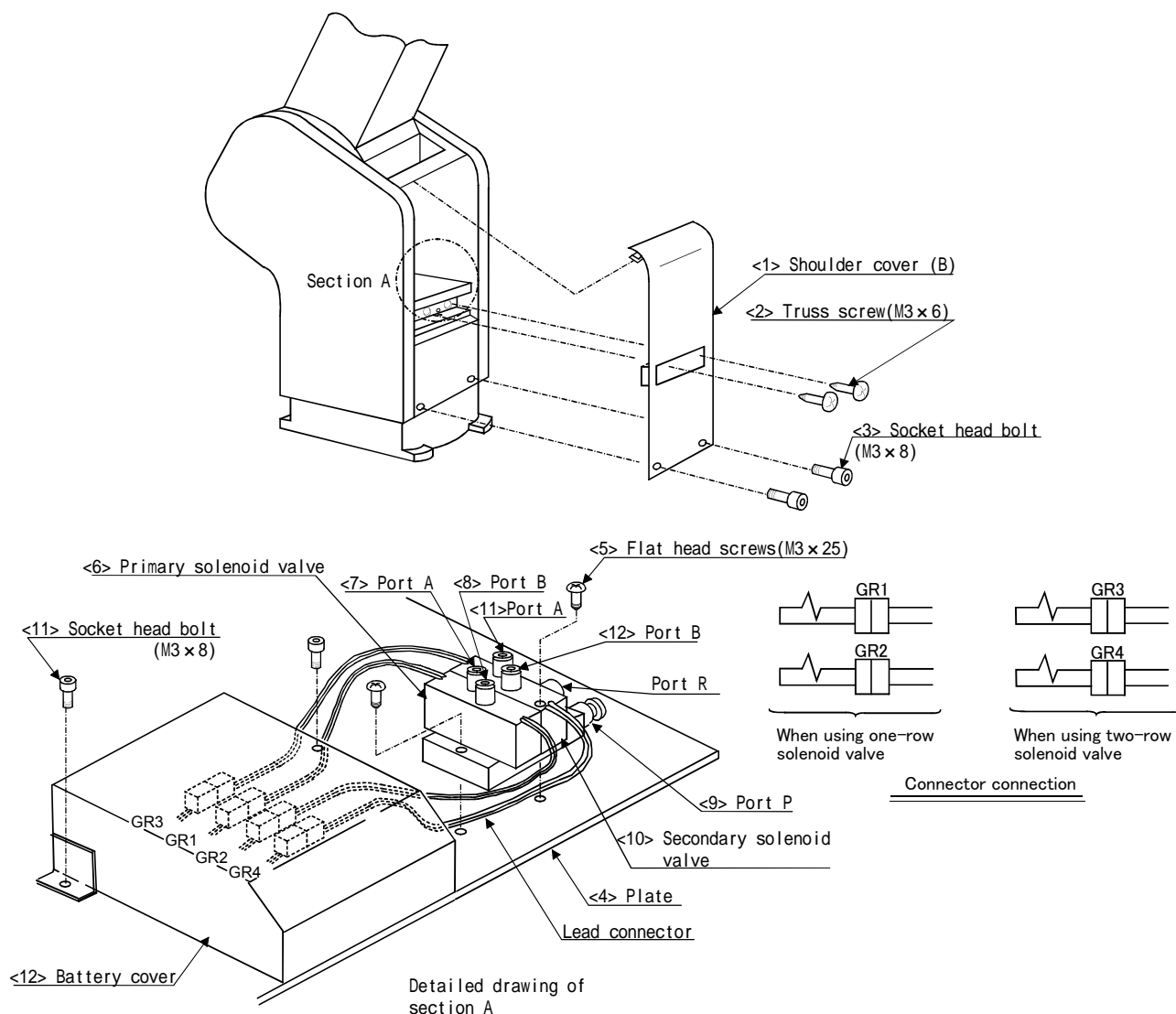

Fig.3-2 : Solenoid valve installation procedures (RV-2AM/3AJM)

- 1) Remove the two (M3x6) screws <2> and the two (M3x8) bolts <3>, and remove the shoulder cover (B) <1>.
- 2) Unfasten the two (M3x8) bolts <11> holding the battery cover <12>, and remove the cover.
- 3) Install the solenoid valve by fastening it with the two attached (M3x25) screws <5> to the screw holes on the plate <4> of the robot arm.
- 4) Connect one of the two ($\phi 6$) pneumatic hoses in section A —the one marked "AIR IN"— to the quick coupling (port P) <9> of the solenoid valve <6>. The primary air flow can now be supplied from the pneumatic port at the base.
- 5) Connect the hose marked "1" to port A <7> on the primary solenoid valve <6>. Connect the hose marked "2" to port B <8> on the primary solenoid valve <6>. If you are using the double type valves (1E-VD02/VD02E), you need to do the following: Connect the hose marked "3" to port A <11> on the secondary solenoid valve <10>. Connect the hose marked "4" to port B <12> on the secondary solenoid valve <10>.
- 6) Connect the GR1 plug protruding from the primary solenoid valve <6> to the connector GR1. Connect the GR2 plug protruding from the primary solenoid valve <6> to the connector GR2. If you are using double type valves (1E-VD02/VD02E): Connect the GR3 plug protruding from the secondary solenoid valve <10> to the connector GR3. Connect the GR4 plug protruding from the secondary solenoid valve <10> to the connector GR4.
- 7) Store the newly attached connectors in the battery cover <12>, and reinstall the battery cover.
- 8) When you have completed the installation, reinstall the shoulder cover (B) <1> to its original position, and be careful not to entangle the cables when you do so.

The connections after the installation appear as in [Table 3-2](#) for single type valves, hand 2 is not applicable.

Table 3-2 : Solenoid valve ports and hoses: Connection table for couplings and hand ports for the RV-2AM/3AJM

Hand	Hand port	Forearm coupling number	Hose number	Solenoid valve port	
Hand 1	OPEN	1	1	A	First set
	CLOSE	2	2	B	
Hand 2	OPEN	3	3	A	Second set
	CLOSE	4	4	B	
Spare	OPEN	5	5		
	CLOSE	6	6		

3.2 Installation the pneumatic hand set (4A-HP02/HP02E)

Table 3-1 shows the construction of the pneumatic hand set and the installation procedure and Table 3-1 shows the configuration equipment which correspond with the Table 3-1.

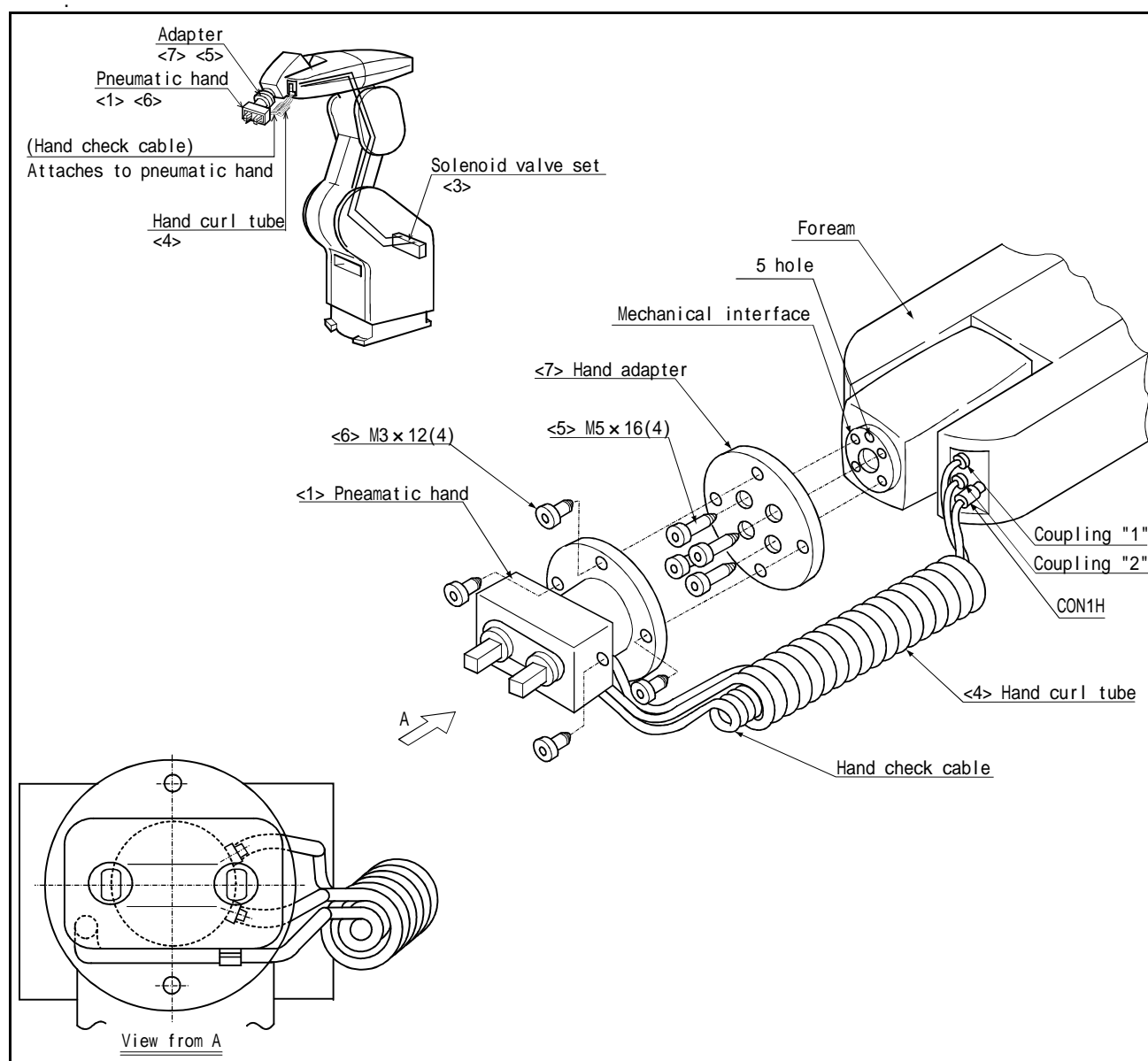

Fig.3-3 : Pneumatic hand set installation procedures

Table 3-3 : Configuration for the pneumatic hand set

Number	Part name	Model	Quantity	Description
<1>	Pneumatic hand	1E-HP01/ 1E-HP01E	1	Hand input cable with pneumatic coupling
<2>	Pneumatic hand interface	2A-RZ365/375	1	Interface board (Install on the controller)
<3>	Solenoid valve set	1E-VD01/ 1E-VD01E	1	Comes with two M3x25 socket head bolts
<4>	Hand curl tube (2 tubes per set)	1E-ST0402C	1	
<5>	Socket head bolts	M5x16	4	
<6>	Socket head bolts	M3x12	4	
<7>	Adapter	BU144D697H01	1	This item is needed for installing <1> above.

3.2.1 Installing the 1E-HP01/1E-HP01E pneumatic hand

Fig. 3-3 shown the method for installing the pneumatic hand. The installation steps are as follows:

- 1) Use four M5x16 hexagon socket head bolts <5> to install the head adapter <7> to the robot arm's mechanical interface.
- 2) Use four M3x12 hexagon socket head bolts <6> to install the pneumatic hand to the hand adapter. Use Fig. 3-3 to find the where the ends of the cables should be connected to the adapter.
- 3) As shown in Fig. 3-3, connect the hand curl tubes to coupling "1" and coupling "2", which protrudes from the cover of the forearm. The opposite end of the tube connected to coupling "1" should be attached to the hand's OPEN coupling, and the opposite end of the tube connected to coupling "2" should be attached to the hand's CLOSED coupling.
- 4) As shown in Fig. 3-3, connect the hand check cable, which is attached to the main unit of the hand, to the connector CON1H, which protrudes from the cover of the forearm. This completes the installation of the hand.

3.2.2 Installing the 1E-VD01/1E-VD01E solenoid valve set

To install the solenoid valve set, refer to "3.1Installing the solenoid valve set(1E-VD01/VD01E/VD02/VD02E)" on page 31 in this manual.

3.2.3 Installing the pneumatic hand interface

To install the pneumatic hand interface, refer to separate manual "CR1 Controller INSTRUCTION MANUAL/ Controller setup, basic operation, and maintenance".

3.2.4 Setting the parameters

For the pneumatic hand (1E-HP01/1E-HP01E), the tool data is 107mm. Refer to separate manual "CR1/CR2/ CR4/CR7/CR8 Controller INSTRUCTION MANUAL/Detailed explanations of functions and operations", and set the value of the MEXTL parameter to 107mm.

3.2.5 Open/close setting of the hand and settings for input signals

The connections for the optional pneumatic hand sensor, and the bit settings for input signals and for the hands open/close setting, are shown in Table 3-4. The hand connector numbers have been assigned numbers from the connector pins located at the end of the forearm.

Table 3-4 : The hand's open/close setting and input signal settings

Hand check connector numbers	Signal	Setting pins for the open/close setting of the hand			Comments
		Open	Half open	Closed	
1	General purposeinput 900	0	1	1	Corresponds to hand 1
2	General purposeinput 901	1	1	0	

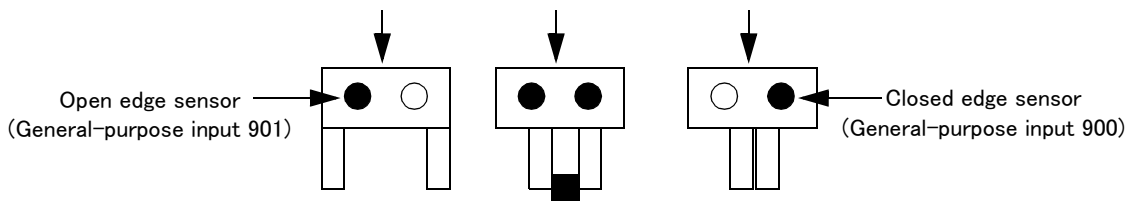

3.2.6 Confirming operability

- 1) Operate the teaching pendant to confirm that the hand opens and closes.
- 2) To operate the teaching pendant, refer to separate manual "CR1/CR2/CR4/CR7/CR8 Controller INSTRUCTION MANUAL/Detailed explanations of functions and operations".
- 3) If the open/close settings are reversed, confirm the connection settings with Table 3-1 or Table 3-2 and reset the settings.



While operating the hand, depending on the J5 axis and J6 axis, the hand curl-tube and the hand check cable can get entangled with the hand adapter and forearm. In this case, temporarily remove the hand, and reposition it to its correctly installed position, as shown in Fig. 3-3.

This completes the installation of the pneumatic hand set.

3.3 Installation the motorized hand set (4A-HM02)

Fig. 3-4 shows the construction of the motorized hand set and the installation procedure and Table 3-5 shows the configuration equipment which correspond with the Fig. 3-4.

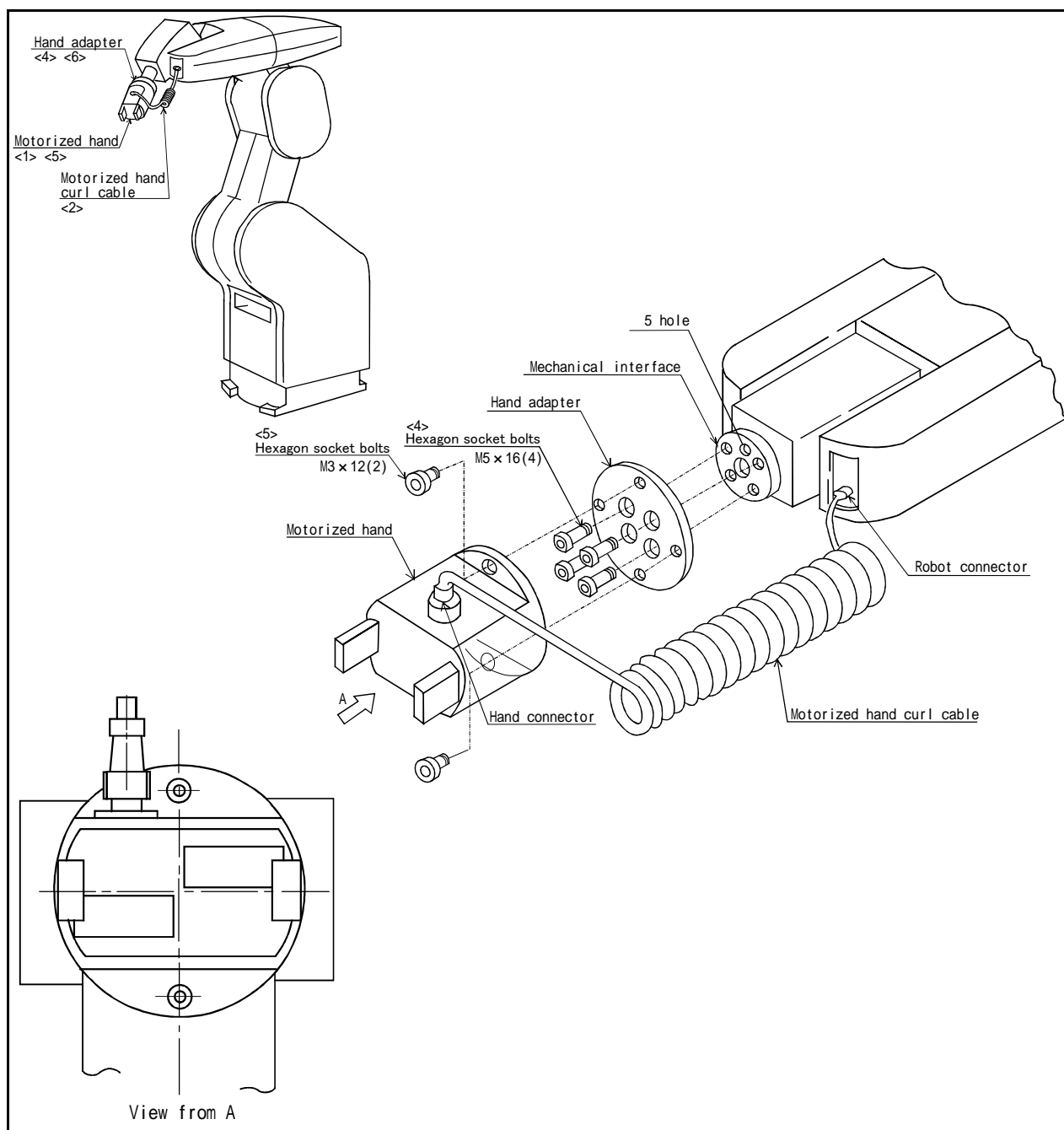

Fig.3-4 : Motorized hand set installation procedures

Table 3-5 : Configurations for the motorized hand set.

Number	Part name	Model type	Quantity	Notes
<1>	Motorozed hand	1A-HM01	1	
<2>	Motorozed hand curl cable	1E-GHCD-1	1	
<3>	Motorozed hand interface	2A-RZ364	1	Install on controller
<4>	Hexagon socket bolts	M5x16	4	
<5>	Hexagon socket bolts	M3x12	2	
<6>	Hand adapter	BU144D697H01	1	

3.3.1 Installing the motorized hand

Fig. 3-4 shows how to install the motorized hand.

- 1) Install the hand adapter to the robot arm's mechanical interface with 4 hexagon socket bolts (M5x16).
- 2) Install the motorized hand to the hand adapter with 2 hexagon socket bolts (M3x12).
Make sure that the position of the hand connector of the motorized hand and the position of the hand adapter are the same as that shown in Fig. 3-4.
- 3) Once the hand has been installed, securely attach the hand curl cable to the hand's connector and to the robot's connector, as shown in Fig. 3-4.
- 4) Move the J5 axis by JOG operation, and confirm that the cable is not hindered.

 **CAUTION** Install the 0 position (the center of the operation range) for the positions of the J5 axis and J6 axis. If you set the installation position inappropriately, the motorized hand curl cable and the hand adapter can get entangled. In such a case, repeat the operation in clause "3)", and change the installation position.

 **CAUTION** There is no mechanical stopper for the J6 axis. Do not manually rotate the J6 axis by more than the operation range (200 degrees) when the servo is OFF. If the axis is rotated by more than operation range when the servo is ON, an encoder alarm occur.

3.3.2 Installation the motorized interface

Refer to the separate "CR1 Controller Instruction Manual/Controller setup, basic operation, and maintenance", and install the motorized hand interface on the controller.

3.3.3 Setting the parameters

When using the motorized hand (1A-HM01), the tool data is 123mm. Refer to separate manual "CR1/CR2/CR4/CR7/CR8 Controller INSTRUCTION MANUAL/Detailed explanations of functions and operations", and set the MEXTL parameters.

3.3.4 Confirming operability

- 1) Operate the teaching pendant to confirm that the hand opens and closes.
- 2) To operate the teaching pendant, refer to separate manual "CR1/CR2/CR4/CR7/CR8 Controller INSTRUCTION MANUAL/Detailed explanations of functions and operations".

 **CAUTION** While operating the hand, depending on the J5 axis and J6 axis, the hand curl-tube and the hand check cable can get entangled with the hand adapter and forearm. In this case, temporarily remove the hand, and reposition it to its correctly installed position, as shown in Fig. 3-4.

 **CAUTION** If the cable is incorrectly fixed and force is repeatedly applied on the connectors due to the robot movement, wire breakage could occur at the connector section.

This completes the installation of the motorized hand set.

3.4 Hand output cable (1E-GR35S)

This hand output cable is used by the customer to connect to the handle output connector on the shoulder section of the robot arm.

Refer to section [“3.1Installing the solenoid valve set\(1E-VD01/VD01E/VD02/VD02E\)”](#), 4) Table 3-1 on page 32 for the connection methods.

3.5 Installing the hand input cable (1E-HC15C) and hand curl tube (1E-ST040*C)

The hand input cable and hand curl tube are used to connect to the hand and sensor manufactured by the customer.

Refer to section [“3.2Installation the pneumatic hand set \(4A-HP02/HP02E\) ”](#) 5) and 6) on page 35 for the installation methods.

4 Basic operations

The basic operations from creating the program to automatic operation are explained in section "4. Basic operations" in the "From Controller Setup to Maintenance" manual. Refer that manual as necessary.

5 Maintenance and Inspection

The maintenance and inspection procedures to be carried out to use the robot for a long time without trouble are described in this chapter. The types and replacement methods of consumable parts are also explained.

5.1 Maintenance and inspection interval

Maintenance and inspection are divided into the inspections carried out daily, and the periodic inspections carry out at set intervals. Always carry these out to prevent unforeseen trouble, to maintain the product for a long time, and to secure safety.

(1) Inspection schedule

In addition to the monthly inspection, add the following inspection items every three months (estimated at 500 Hr operation hours).

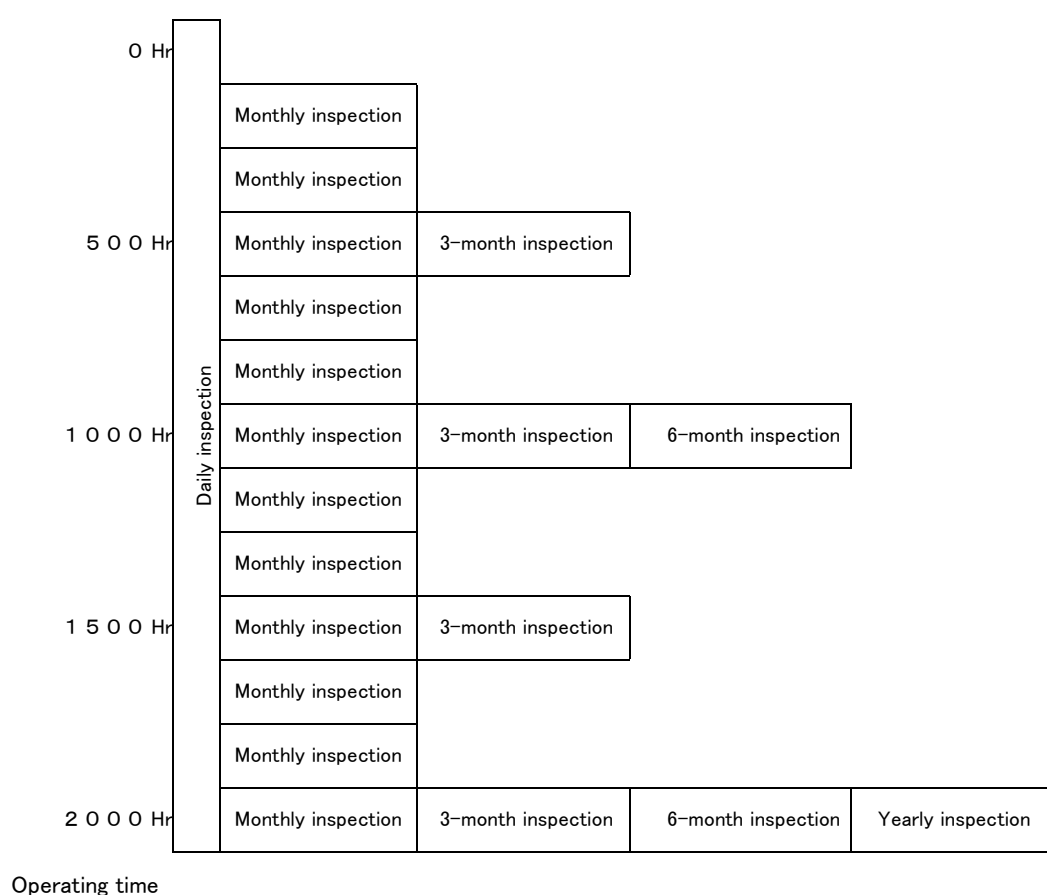

<Guideline for inspection period>

For one shift

$$8 \text{ Hr/day} \times 20 \text{ days/month} \times 3 \text{ months} = \text{approx. } 500 \text{ Hr}$$

$$10 \text{ Hr/day} \times 20 \text{ days/month} \times 3 \text{ months} = \text{approx. } 600 \text{ Hr}$$

For two shifts

$$15 \text{ Hr/day} \times 20 \text{ days/month} \times 3 \text{ months} = \text{approx. } 1000 \text{ Hr}$$

[Caution] When using two lines, the 3-month inspection, 6-month inspection and yearly inspection must be carried out when half the time has passed.

Fig.5-1 : Inspection schedule

5.2 Inspection items

The inspection items for the robot arm are shown below.

Also refer to section “5. Maintenance and inspection” in the “Controller setup, basic operation, and maintenance” manual, and inspect the controller.

5.2.1 Daily inspection items

Carry out the daily inspections with the procedures given in [Table 5-1](#).

Table 5-1 : Daily inspection items (details)

Procedure	Inspection item (details)	Remedies
Before turning power ON (Check the following items before turning the power ON.)		
1	Are any of the robot installation bolts loose? (Visual)	Securely tighten the bolts.
2	Are any of the cover tightening screws loose? (Visual)	Securely tighten the screws.
3	Are any of the hand installation bolts loose? (Visual)	Securely tighten the bolts
4	Is the power supply cable securely connected? (Visual)	Securely connect.
5	Is the machine cable between the robot and controller securely connected? (Visual)	Securely connect.
6	Are there any cracks, foreign contamination or obstacles on the robot and controller cover?	Replace with a new part, or take remedial measures.
7	Is any grease leaking from the robot arm? (Visual)	After cleaning, replenish the grease.
8	Is there any abnormality in the pneumatic system? Are there any air leaks, drain clogging or hose damage? Is the air source normal? (Visual)	Drain the drainage, and remedy the air leaks (replace the part).
After turning the power ON (Turn the power ON while monitoring the robot.)		
1	Is there any abnormal motion or abnormal noise when the power is turned ON?	Follow the troubleshooting section.
During operation (try running with an original program)		
1	Check whether the movement points are deviated? Check the following points if there is any deviation. 1. Are any installation bolts loose? 2. Are any hand installation section bolts loose? 3. Are the positions of the jigs other than the robot deviated? 4. If the positional deviation cannot be corrected, refer to “Troubleshooting”, check and remedy.	Follow the troubleshooting section.
2	Is there any abnormal motion or abnormal noise? (Visual)	Follow the troubleshooting section.

5.2.2 Periodic inspection

Carry out periodic inspection with the procedures given in [Table 5-2](#).

Table 5-2 : Periodic inspection items (details)

Procedure	Inspection item (details)	Remedies
Monthly inspection items		
1	Are any of the bolts or screws on the robot arm loose?	Securely tighten the bolts.
2	Are any of the connector fixing screws or terminal block terminal screws loose?	Securely tighten the screws.
3	Remove the cover at each section, and check the cables for wear damage and adherence of foreign matter.	Check and eliminate the cause. If the cables are severely damaged, contact the Mitsubishi Service Department.
4	It runs out of grease on the spring shaft for J2 axis.	Refer to " 5.3.6How to lubricate the spring shaft area " on page 62 and lubricate it.
3-month inspection items		
1	Is the timing belt tension abnormal? Is the inside of the arm dirty?	If the timing belt is loose or too tense, adjust it. Wipe the dust with dry cloth or with alcohol.
6-month inspection items		
1	Is the friction at the timing belt teeth severe?	If the teeth are missing or severe friction is found, replace the timing belt.
Yearly inspection items		
1	Replace the backup battery in the robot arm.	Exchange it referring to " 5.3.7Replacing the backup battery " on page 63.
2-year inspection items		
1	Lubricate the grease at the harmonic reduction gears for each axis.	Lubricate it referring to " 5.3.5Lubrication " on page 54.

5.3 Maintenance and inspection procedures

The procedures for carrying out the periodic maintenance and inspection are described in this section. Thoroughly read the contents, and follow the instructions. This work can be commissioned to the Mitsubishi Service Department for a fee. (Never disassemble, etc., the parts not described in this manual.)

The maintenance parts, etc., required for the user to carry out maintenance and inspection are described in "5.4 Maintenance parts" on page 65 of this manual. Always contact your dealer when parts are needed.



CAUTION

The origin of the machine system could deviate when this work is carried out. "Review of the position data" and "re-teaching" will be required.

5.3.1 Robot arm structure

An outline structure drawing of the 5-axis type robot arm is shown in Fig. 5-2, and of the 6-axis type robot arm in Fig. 5-3. Each part is as shown below.

- 1) The J1 axis rotation is driven by the J1 axis motor <1> and reduction gears <2> arranged in the shoulder. Non-excitation magnetic brakes are mounted in the J1 axis motor <1>.
- 2) The J2 axis rotation is driven by the J2 axis motor <3> and reduction gears <4> arranged in the shoulder. Non-excitation magnetic brakes are mounted in the J2 axis motor <3>.
- 3) The J3 axis rotation is driven by the J3 axis motor <5> and reduction gears <6> arranged in the upper arm. Non-excitation magnetic brakes are mounted in the J3 axis motor <5>.
- 4) The J4 axis rotation of 6-axis type is driven by the J4 axis motor <7> and reduction gears <8> arranged in the elbow block.
- 5) The rotation of the J5 axis motor <9> arranged in the forearm is conveyed to the reduction gears <11> via the timing belt <10> to rotate the wrist housing and following parts. Non-excitation magnetic brakes are mounted in the J5 axis motor <9>.
- 6) The rotation of the J6 axis is driven by the J6 axis motor <12> arranged in the wrist housing and the reduction gears <13>.

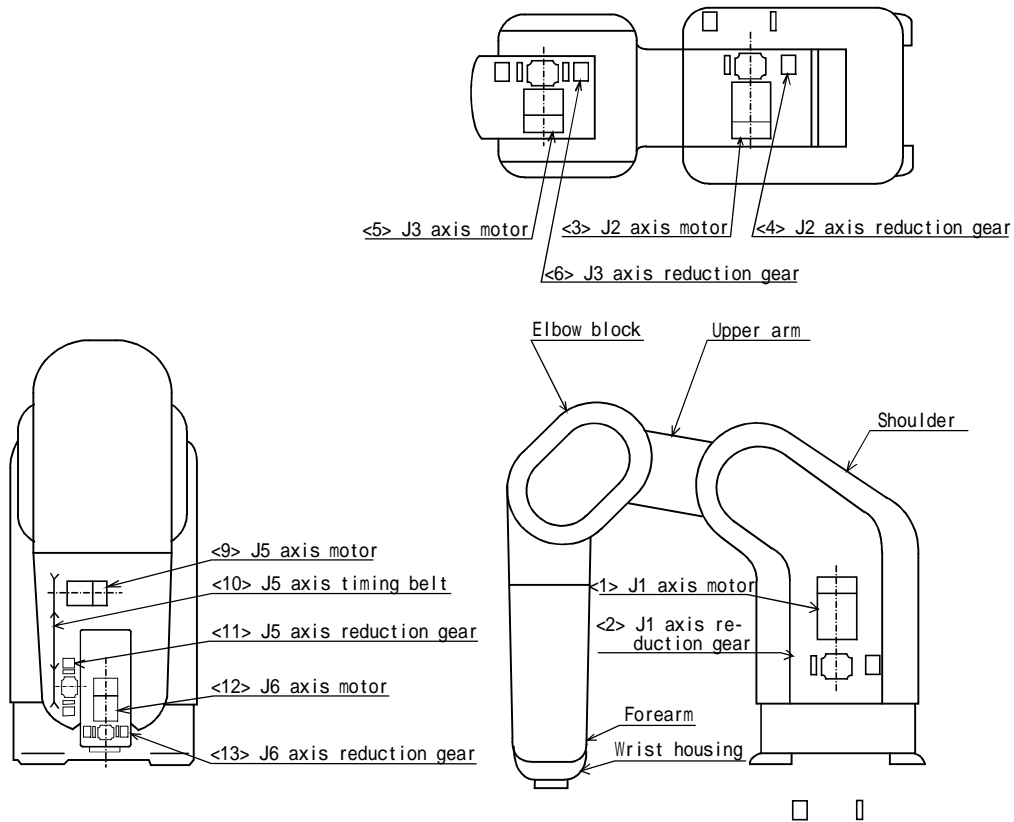

Fig.5-2 : Outline structure drawing of robot arm (5-axis type)

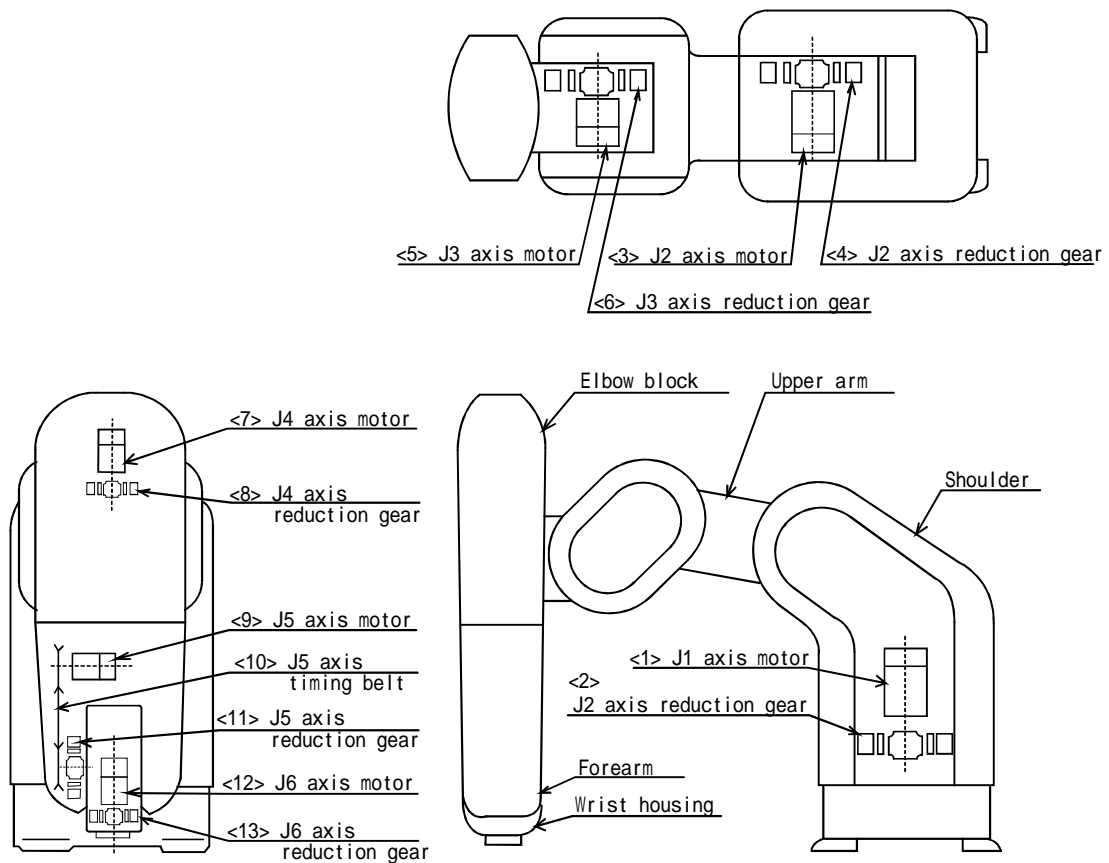

Fig.5-3 : Outline structure drawing of robot arm (6-axis type)

5.3.2 Installing/removing the cover

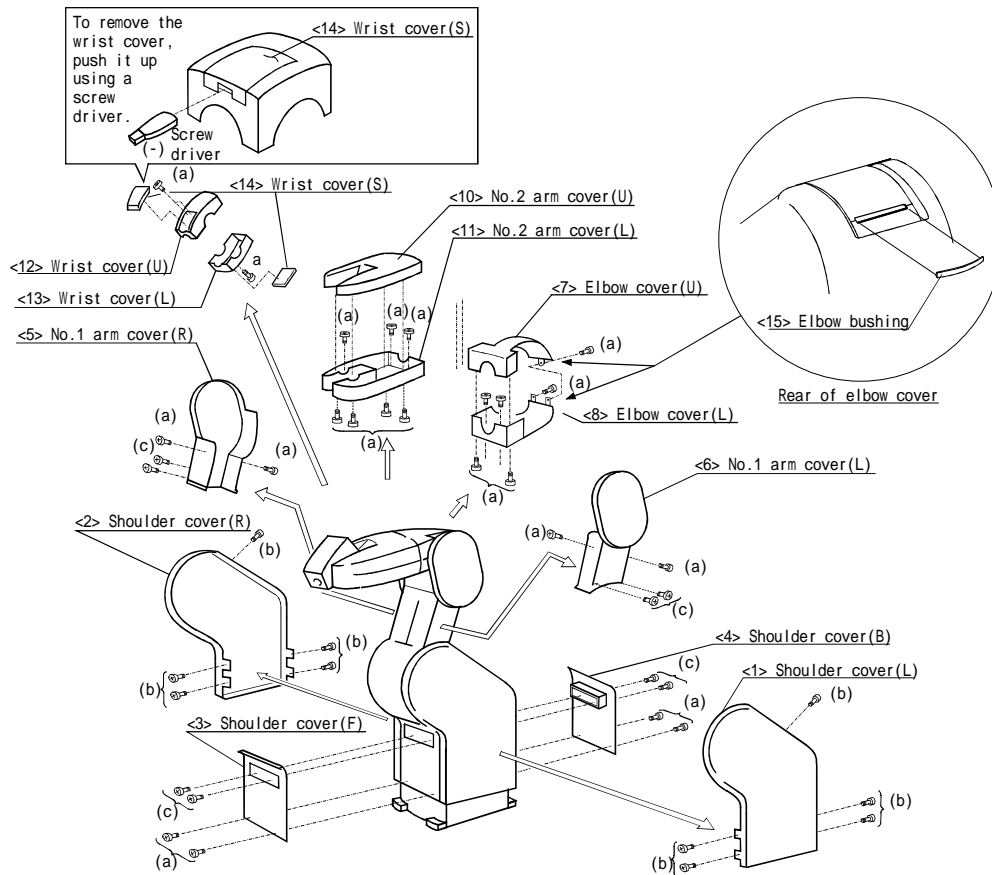

Fig.5-4 : Installing/removing the cover (5-axis type)

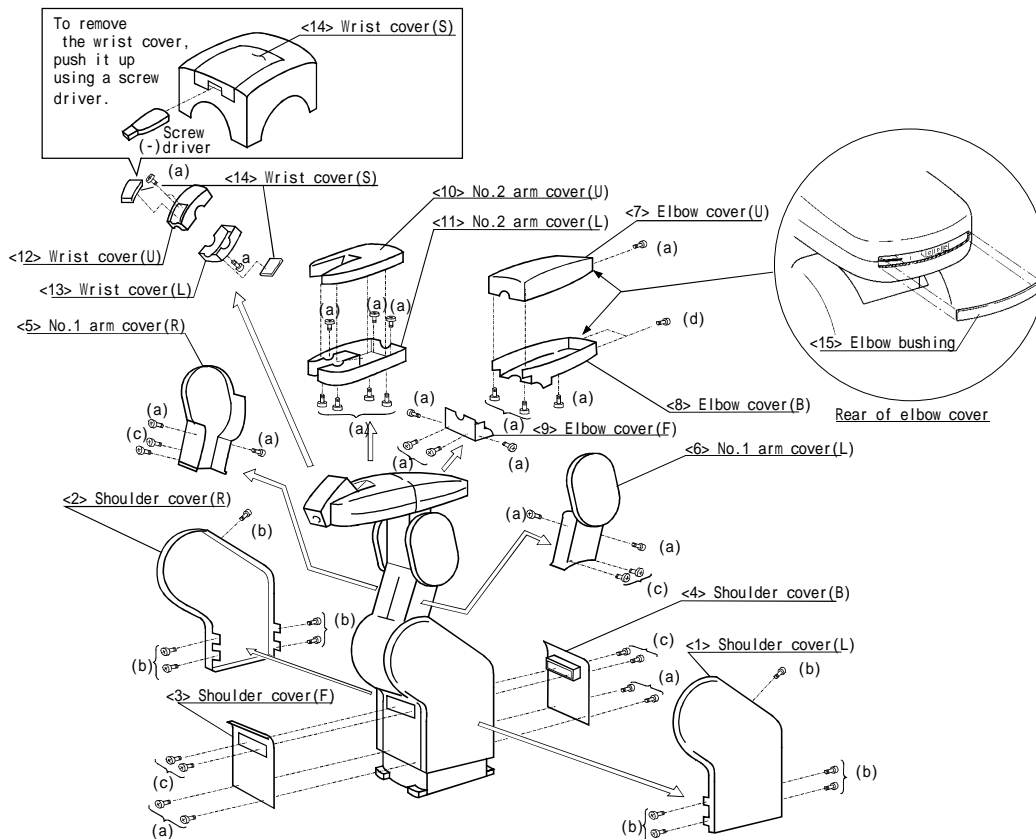

Fig.5-5 : Installing/removing the cover (6-axis type)

Table 5-3 : Cover names

No	Cover names	Qty.		Remarks
		5-axis type	6-axis type	
<1>	Shoulder cover (L)	1	1	
<2>	Shoulder cover (R)	1	1	
<3>	Shoulder cover (F)	1	1	
<4>	Shoulder cover (B)	1	1	
<5>	No. 1 arm cover (R)	1	1	
<6>	No. 1 arm cover (L)	1	1	
<7>	Elbow cover (U)	1	1	The packing (C) is attached to clean specification of 5-axis type. The packing (D) is attached to clean specification of 6-axis type.
<8>	Elbow cover (B)	0	1	The packing (A) and (D) are attached to clean specification.
	Elbow cover (L)	1	0	The packing (C) is attached to clean specification.
<9>	Elbow cover (F)	1	1	
<10>	No. 2 arm cover (U)	1	1	The packing (C) and (D) are attached to clean specification.
<11>	No. 2 arm cover (L)	1	1	The packing (C) and (D) are attached to clean specification. The rubber packing is attached to protection specification.
<12>	Wrist cover (U)	1	1	The packing (B) is attached to protection and clean specification.
<13>	Wrist cover (L)	1	1	The packing (B) and (C) are attached to clean specification. The rubber packing and packing (B) are attached to protection specification.
<14>	Wrist cover (S)	2	2	
<15>	Elbow bushing	1	1	The silicone seal applies to clean specification.

Note) The packing which showed in remarks is attached to protection and clean specification. Refer to "Table 5-7 : Spare parts list" on page 65 for type name of packing.

Table 5-4 : Cover installation screw list

No.	Installation screw name	Qty.	Remarks
(a)	Socket bolt M3 x 8 (nickel plated)	27	
(b)	Truss screw M3 x 6 (nickel plated)	10	
(c)	Truss screw M3 x 8 (nickel plated)	8	
(d)	Socket bolt M3 x 6 (nickel plated)	2	6-axis type only

The method of cover installation/removal are all model commonness basically.

However, to secure the cleanliness, the packing and sealing are attached to clean specification.

■ The elbow bushing <15> at the rear of the elbow cover

The elbow section is sealed with a sealing agent (silicon seal, refer to Table 5-7) around the elbow bushing.

When removing and reinstalling the elbow cover, apply silicon seal around the elbow bushing to seal it. Wipe out the silicon seal which protruded after the installation.

■ The No.2 arm cover U/L <10>/<11>, elbow cover U/B/L <7>/<8>, wrist cover U/L <12>/<13>

Sponge packing is attached on the inner side of these covers.

So when removing/installing these covers make sure not to damage the packing.

The installing/removing the cover procedures are shown below.

- Refer to Fig. 5-4 when using the 5-axis type robot arm, and Fig. 5-5 when using the 6-axis type robot arm, and remove the cover.
- The names of the covers are given in Table 5-3, and a list of the cover installation screws is given in Table 5-4.
- There are some covers that may be difficult to remove due to the robot posture. In this case, change the robot posture with jog operation, and then remove the cover.
- When attaching the cover after maintenance and inspection, use the detaching procedure in reverse.

The part Nos. and symbols in Table 5-3 and Table 5-4 correspond to Fig. 5-4 and Fig. 5-5.

5.3.3 Inspection, maintenance and replacement of timing belt

This robot uses a timing belt for the drive conveyance system of the J5 axis. Compared to gears and chains, the timing belt does not require lubrication and has a low noise. However, if the belt usage method and tension adjustment are inadequate, the life could drop and noise could be generated. Sufficient aging to remove the initial elongation of the belt, and adjustment of the belt tension have been carried out before shipment from the factory. However, depending on the robot working conditions, elongation will occur gradually over a long time. The tension must be confirmed during the periodic inspection. The timing belt must be replaced in the following cases.

(1) Timing belt replacement period

The timing belt life is greatly affected by the robot working conditions, so a set time cannot be given. However, if the following symptoms occur, replace the belt.

- 1) When cracks form at the base or back of the belt teeth.
- 2) When the belt expands due to adherence of oil, etc.
- 3) When the belt teeth wear (to approx. half of the tooth width).
- 4) When the belt teeth jump due to belt teeth wear.
- 5) When the belt snaps.



CAUTION

Due to the manufacturing of the timing belt, initial wear will occur. Wear chips may accumulate in the cover after approx. 300 Hr of operating the robot, but this is not a fault. If the wear chips appear soon after wiping them off, replace the belt.



CAUTION

When the belt is replaced, the machine system origin may deviate. In this case, the position data must be reviewed.

(2) Inspection, maintenance and replacement of J5-axis timing belt

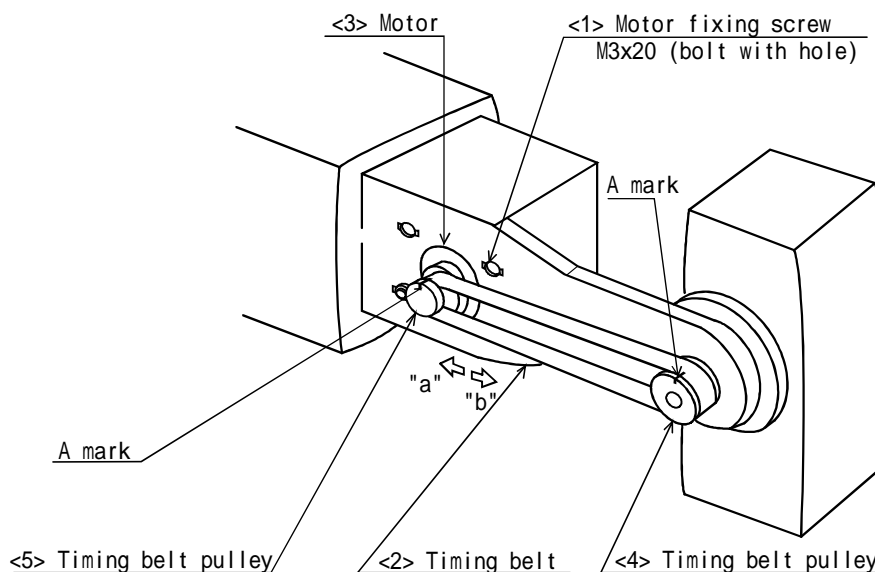

Fig.5-6 : Inspection, maintenance and replacement of J5-axis timing belt

■ Inspecting the J5 axis timing belt

- 1) Confirm that the robot controller power is OFF.
- 2) Refer to "5.3.2 Installing/removing the cover" on page 48, and remove the No. 2 arm cover (U), (L).
- 3) Visually confirm that the symptoms indicated in "(1)Timing belt replacement period" have not occurred with the timing belt.
- 4) Confirm that the belt tension is adjusted to slacken approx. 1.9mm when the center of the belt is lightly pressed with a finger (approx. 0.7N) as shown in "Fig.5-7 : Belt tension".

■ Adjusting the J5 axis timing belt

- 1) Carry out steps "1)" and "2)" indicated in "■ Inspecting the J5 axis timing belt" above.
- 2) Lightly loosen the four motor installation bolts <1>. (Do not loosen too much.)
- 3) While confirming the tension of the timing belt <2>, move the motor <3> in the direction of the arrow shown in the figure. Move until the belt slackens approx. 1.9mm when the center of the belt is lightly pressed with a finger (approx. 0.7N).
- 4) The belt tension will increase when moved in the direction of arrow "a", and will decrease when moved in the direction of arrow "b".
- 5) If the belt is loosened too much when adjusting the tension causing it to come off the timing pulleys <4> and <5>, or if the belt and pulley teeth engagement is deviated, the machine system's origin will deviate.
- 6) After adjusting, securely tighten the four motor installation bolts <1>. Improper tightening can cause the belt to loosen with vibration.

■ Replacing the J5 axis timing belt

- 1) Fig. 5-6 shows the methods for inspecting, adjusting and replacing the timing belt.
- 2) Move the robot posture with the teaching pendant so that the J5 axis may be downward. (Turn it to the direction of gravity.)
Make sure that the pulleys do not move while replacing the belt.
- 3) If the pulley <4> and <5> position relation deviates, the position could deviate.
- 4) Make marks on the timing belt <2> and timing pulleys <4> and <5> with a felt-tip pen as shown in Fig. 5-6 so that the engagement of the timing belt <2> and timing pulleys <4> and <5> does not deviate.
- 5) Loosen the four motor installation screws <1>, and remove the belt.
- 6) Copy the marks onto the new timing belt. Make sure that both belts are tense when making the marks.
- 7) Align the new timing belt with the marks on the timing pulleys <4> and <5>, and install.
- 8) Refer to steps "3)" to "6)" in "■ Adjusting the J5 axis timing belt" and "(3)Timing belt tension" to adjust the tension.
- 9) The position could deviate after the belt is replaced. Confirm that the position has not deviated. If deviated, refer to "5.5 Resetting the origin" on page 66, and reset the origin position.

(3) Timing belt tension

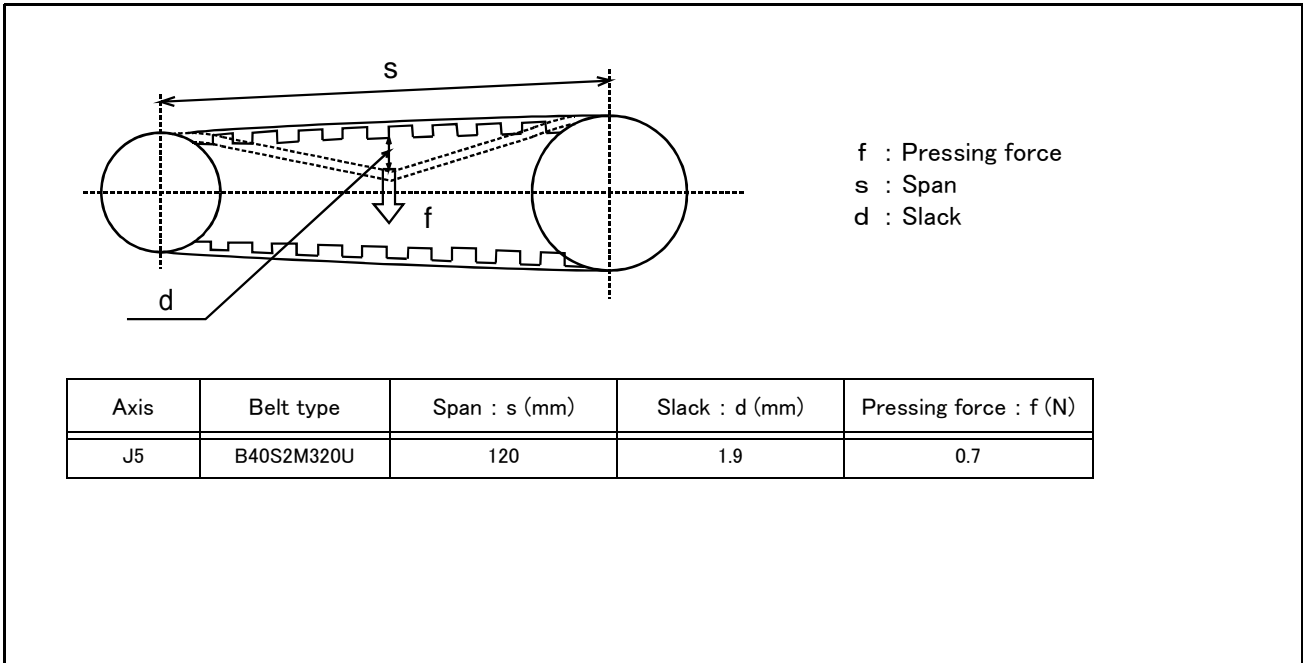

Fig.5-7 : Belt tension

The timing belt can satisfactorily convey the drive and keep a durable force only when it has an adequate tension. The belt tension should not be too tight or too loose. Instead, it should be adjusted to a degree that elasticity is felt when the belt is pressed with the thumb. If the belt tension is too weak, the belt loosening side will vibrate. On the other hand, if the belt tension is too strong, a sharp sound will be heard and the belt tension side will vibrate. The detailed adjustment (tension) is shown in Fig. 5-7. Check and adjust with the belt pressing force f and the slack amount d between span s.

5.3.4 Cleaning inside the cover of clean specification (RV-2AC-SA/SB, RV-3AJC-SA/SB)

This robot has dust generating elements (timing pulley, timing belt) in the No.2 arm cover U/L, thus, the inside must be cleaned periodically. Clean these areas once every three months (500 hours).

- 1) Refer to "5.3.2Installing/removing the cover" on page 48, and remove the No.2 arm cover U/L
- 2) Wipe the dust sticking on the inside of cover with dry cloth or with alcohol. Take care not to damage the sponge packing attached on the No.2 arm cover U/L at this time.
- 3) Wipe the dust sticking on the inside of forearm with dry cloth or with alcohol. Take care not to damage the sponge packing attached on the forearm at this time.
- 4) Install the No.2 arm cover which removed with the above step "1)". Take care not to damage the above sponge packing at this time

This completes the cleaning inside the cover.

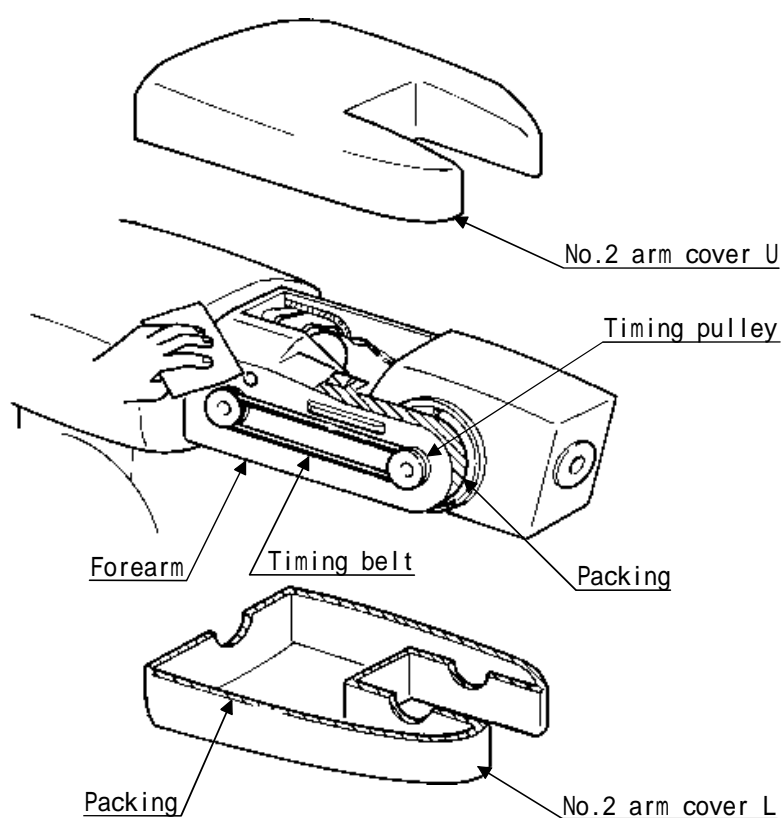

Fig. 5-8 : No.2 arm cover cleaning methods of clean specification

5.3.5 Lubrication

(1) Lubrication position and specifications

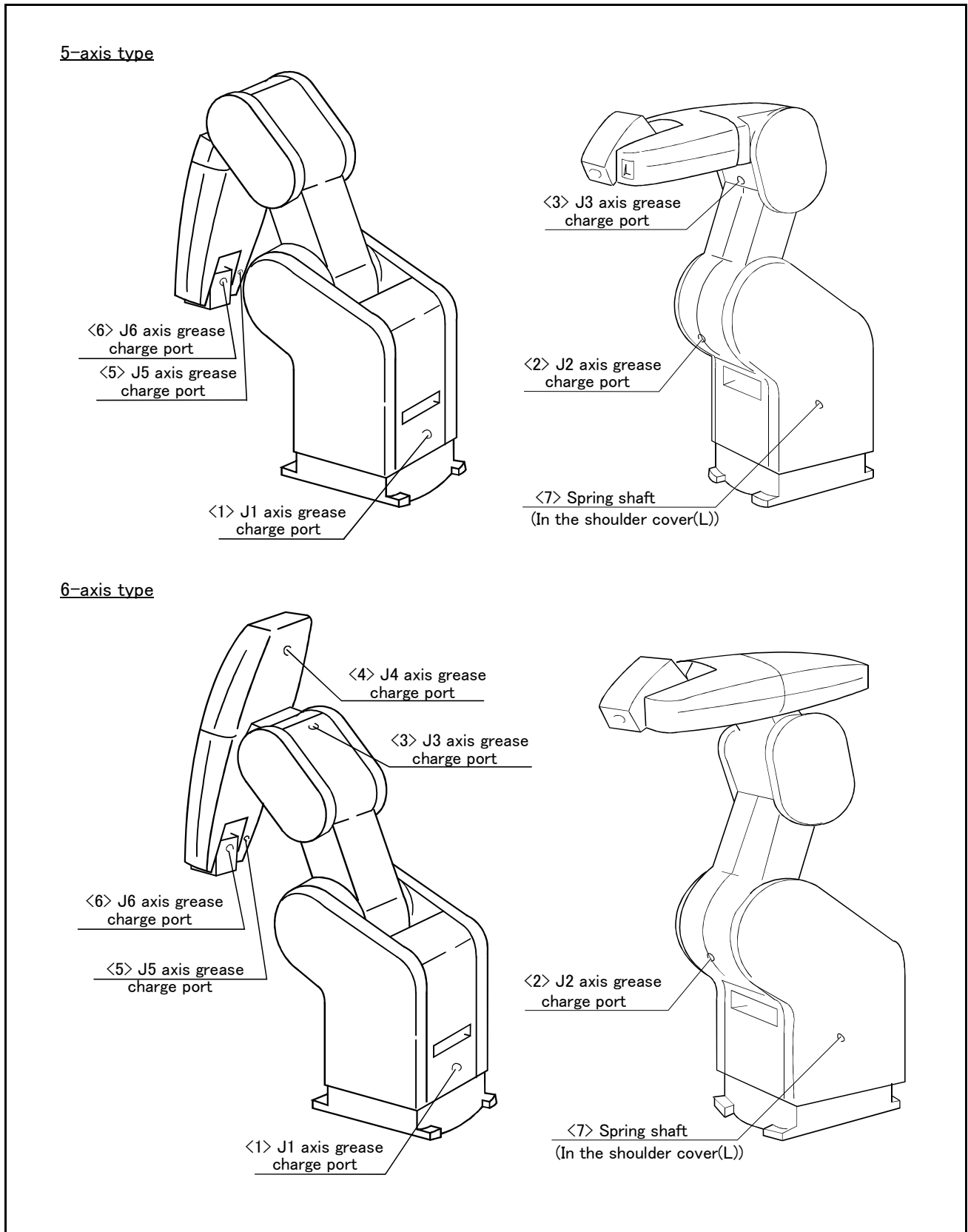

Fig.5-9 : Lubrication positions

Table 5-5 : Lubrication specifications

No.	Parts to be lubricated	Oiling method	Lubrication oil (maker)	Default charge amount	Lubrication interval	Lubrication amount	Cover to remove
<1>	J1 axis reduction gears	Grease nipple WA-610	Grease Harmonic grease SK-1A (Japan Harmonic Systems)	70g	4000Hr	2.5 g	Shoulder cover (B)
<2>	J2 axis reduction gears			30 g		10.5 g	
<3>	J3 axis reduction gears			30 g		10.5 g	
<4>	J4 axis reduction gears (6-axis type only)		Grease Harmonic grease SK-1A (Japan Harmonic Systems)	17g		5.5 g	
<5>	J5 axis reduction gears			7g		1.5 g	
<6>	J6 axis reduction gears			11g		2.5 g	Wrist cover (S)
<7>	Spring shaft in the base	Paint	Shell Alvania Grease No.2	1g	when wear is detected Note1)	1g	Shoulder cover (L)

Note1) If wear is detected during periodical inspections, apply the grease.

The grease nipple position is shown in Fig. 5-9. The lubrication specifications for each place are shown in Table 5-5.

[Caution]

- The brands of grease given in Table 5-5 are those filled when the robot is shipped.
- The lubrication time is a cumulative value of the operation at the maximum speed. If the operation has been suspended, or if the designated speed is slow, the lubrication time can be lengthened in proportion. (The "Lubrication interval" in Table 5-5 is usually based on the 2-year inspection. 8Hr x 20 days x 24 months = 4000Hr.)
- Depending on the robot operation state, the lubrication time will fluctuate, so determine the time according to the state so that the grease does not run out.
- The numbers in the Table 5-5 correspond to the supply positions in Fig. 5-9.

(2) Reduction gears lubrication method

The reduction gears lubrication method is shown below. Refer to the "5.3.2 Installing/removing the cover" on page 48 and remove the covers.

■ J1 axis lubrication method

Fig. 5-10 shows the procedures for J1 axis lubrication method.

- 1) Remove the shoulder cover F/B/L.
- 2) In the case of clean specification, remove the air purging bolt <1>. Take care not to lose the washer with seal at this time. There is no air purging bolt except for the clean specification.
- 3) Lubricate the grease shown in the Table 5-5 from grease nipple <2>.
- 4) In the case of clean specification, tighten the air purging bolt <1> which removed with the above step "2)". Do not forget to attach the washer with seal.
- 5) Install the cover which removed with the above step "1)".

This completes the J1 axis lubrication.

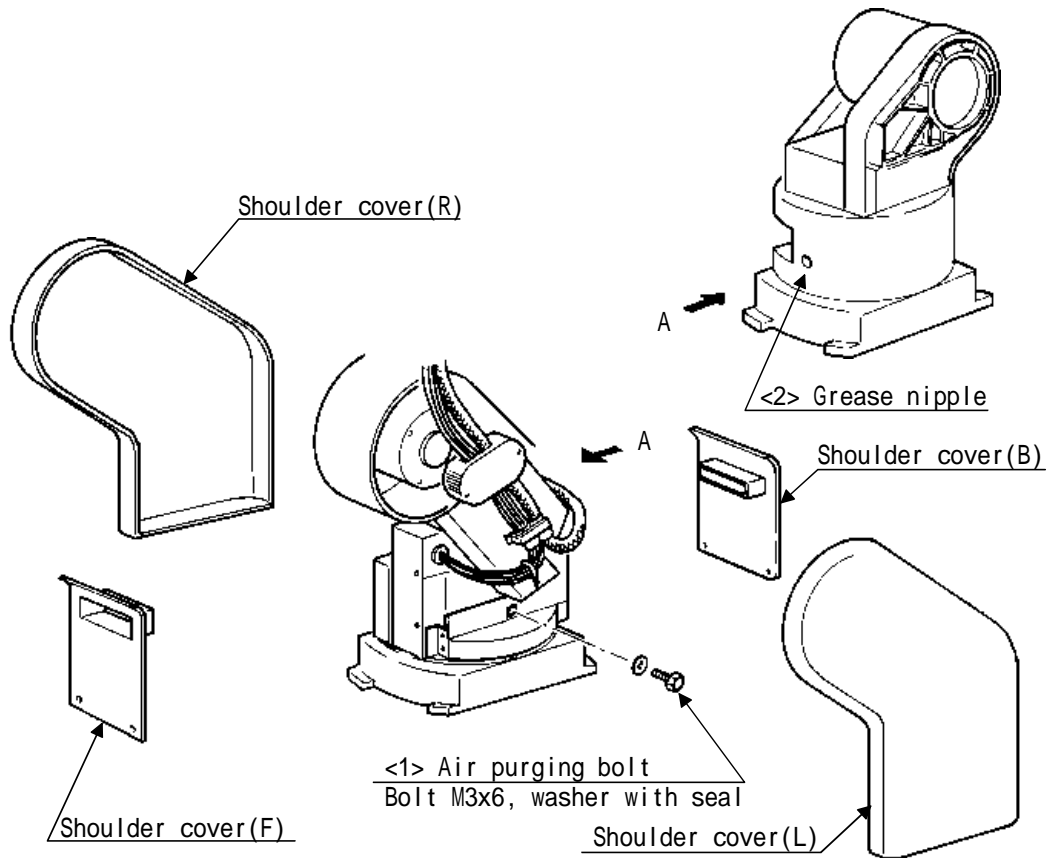

Fig. 5-10 : J1 axis lubrication method

■ J2 axis lubrication method

Fig. 5-11 shows the procedures for J2 axis lubrication method.

- 1) Remove the shoulder cover F/B/R.
- 2) Remove the air purging bolt <1>. Take care not to lose the washer with seal at this time. There is air purging bolt in the J2 axis for all type.
- 3) Lubricate the grease shown in the Table 5-5 from grease nipple <2>.
- 4) Tighten the air purging bolt <1> which removed with the above step "2)". Do not forget to attach the washer with seal.
- 5) Install the cover which removed with the above step "1)".

This completes the J2 axis lubrication.

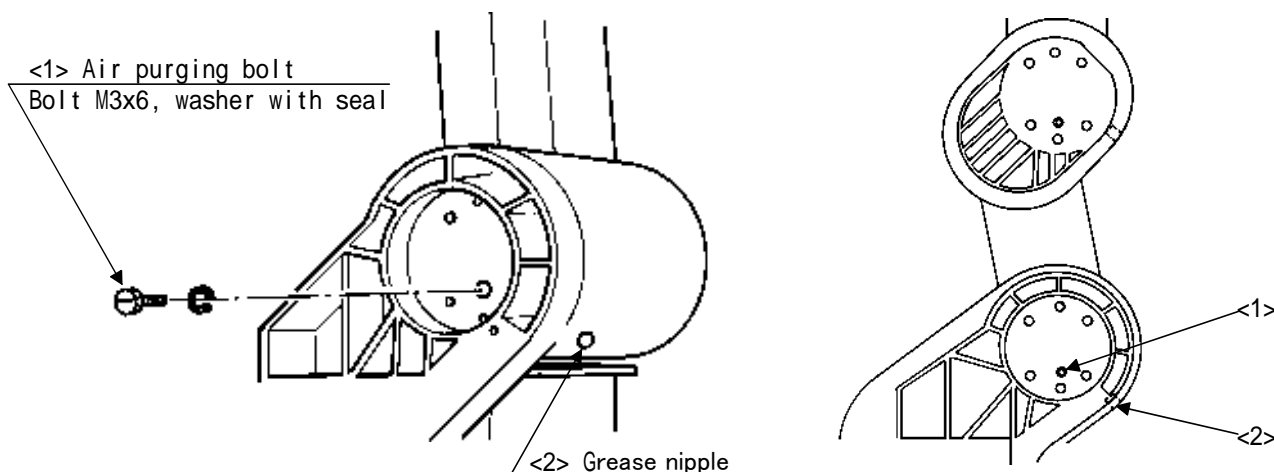

Fig.5-11 : J2 axis lubrication method

■ J3 axis lubrication method

Fig. 5-12 shows the procedures for J3 axis lubrication method.

- 1) Remove the shoulder cover F/B/R and No.2 arm cover R.
- 2) Remove the air purging bolt <1>. Take care not to lose the washer with seal at this time. There is air purging bolt in the J3 axis for all type.
- 3) Lubricate the grease shown in the Table 5-5 from grease nipple <2>.
- 4) Tighten the air purging bolt <1> which removed with the above step "2)". Do not forget to attach the washer with seal.
- 5) Install the cover which removed with the above step "1)".

This completes the J3 axis lubrication.

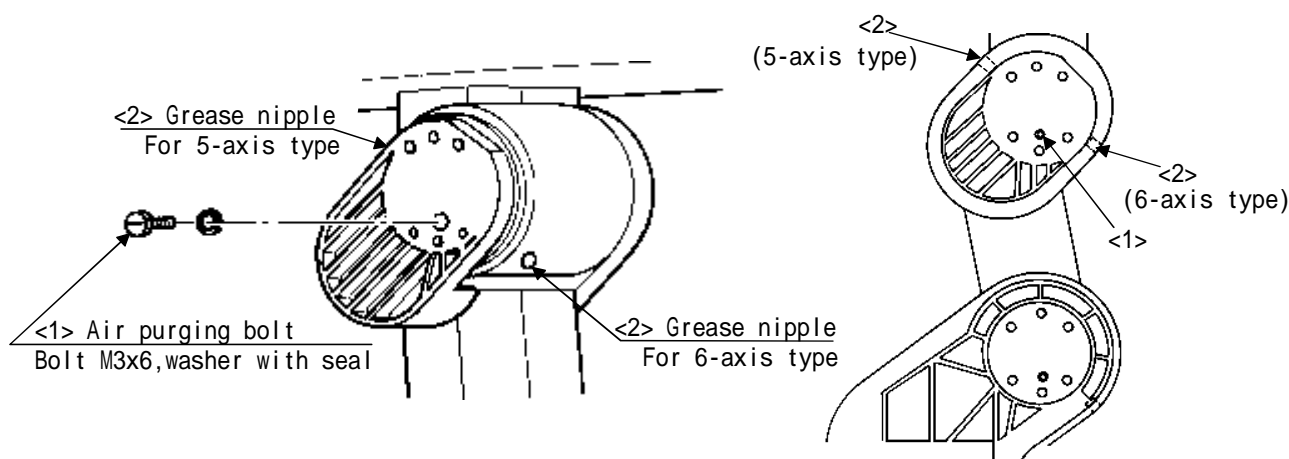

Fig.5-12 : J3 axis lubrication method

■ J4 axis lubrication method (for only 6-axis type)

Fig. 5-13 shows the procedures for J4 axis lubrication method.

- 1) Remove the elbow cover U. Do not remove the elbow cover F/B.
- 2) In the case of clean specification, remove the air purging bolt <1>. Take care not to lose the washer with seal at this time. There is no air purging bolt except for the clean specification.
- 3) Lubricate the grease shown in the Table 5-5 from grease nipple <2>.
- 4) In the case of clean specification, tighten the air purging bolt <1> which removed with the above step "2)". Do not forget to attach the washer with seal.
- 5) Install the cover which removed with the above step "1)". In the case of clean specification, take care not to damage the packing attached to the cover matching surface at this time.

This completes the J4 axis lubrication.

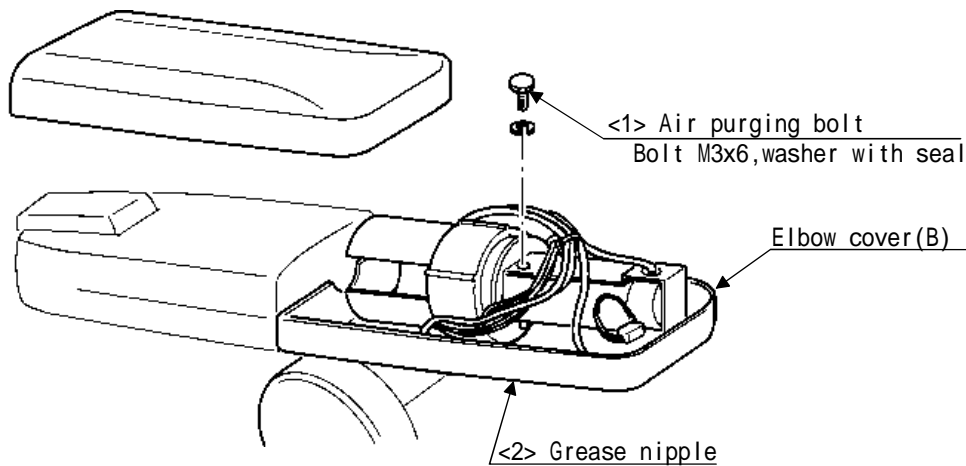

Fig.5-13 : J4 axis lubrication method

■ J5 axis lubrication method

Fig. 5-14 shows the procedures for J5 axis lubrication method.

- 1) Remove the No.2 arm cover U.
- 2) In the case of clean specification, remove the air purging bolt <1>. Take care not to lose the washer with seal at this time. There is no air purging bolt except for the clean specification.
- 3) Lubricate the grease shown in the Table 5-5 from grease nipple <2>.
- 4) In the case of clean specification, tighten the air purging bolt <1> which removed with the above step "2)". Do not forget to attach the washer with seal.
- 5) Install the cover which removed with the above step "1)". In the case of clean specification, take care not to damage the packing attached to the cover matching surface at this time.

This completes the J5 axis lubrication.

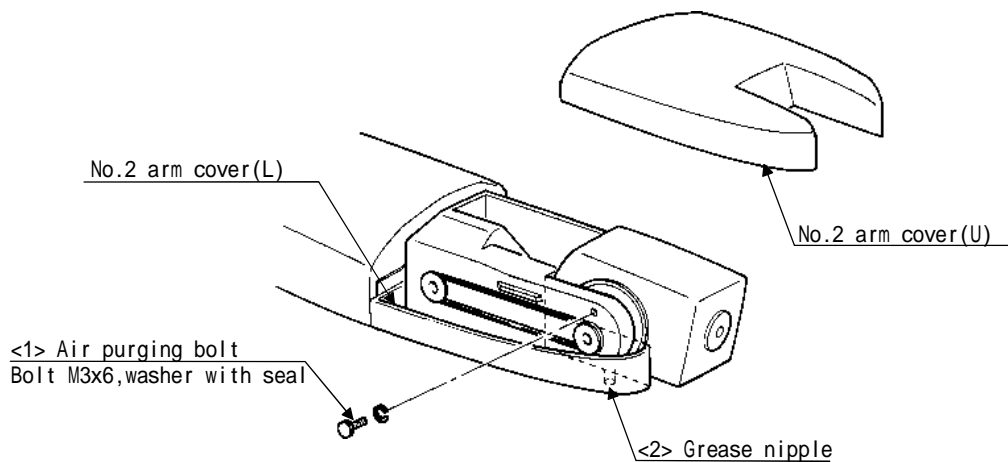

Fig.5-14 : J5 axis lubrication method

■ J6 axis lubrication method

Fig. 5-15 shows the procedures for J6 axis lubrication method.

- 1) Remove the wrist cover S. (top and bottom of wrist)
- 2) In the case of clean specification, remove the air purging bolt <1>. Take care not to lose the washer with seal at this time. There is no air purging bolt except for the clean specification.
- 3) Lubricate the grease shown in the [Table 5-5](#) from grease nipple <2>.
- 4) In the case of clean specification, tighten the air purging bolt <1> which removed with the above step "2)". Do not forget to attach the washer with seal.
- 5) Install the cover which removed with the above step "1)". In the case of clean specification, take care not to damage the packing attached to the cover matching surface at this time.

This completes the J6 axis lubrication.

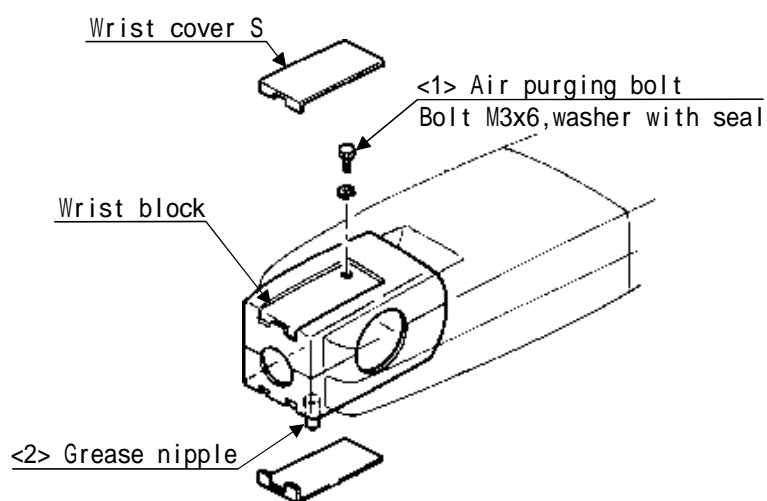

Fig.5-15 : J6 axis lubrication method

(3) Oil seal section lubrication method (for only clean specification)

The clean specification use the oil seal at between the wrist housing and forearm, at the end of the wrist housing and between the elbow block and forearm. (Oil seal: Refer to "Table 5-6: Consumable part list" on page 65) The oil seal section lubrication method is shown below.



CAUTION

The grease used here will generate toxic decomposition gases at high temperatures exceeding 280 °C . Do not light cigarettes with this grease on the hands.



CAUTION

Read the precautions enclosed with the grease before starting work.

■ Lubrication between wrist housing and forearm

Fig. 5-16 shows the procedures for Lubrication method between wrist housing and forearm. Refer to the "5.3.2 Installing/removing the cover" on page 48 and remove the necessary covers.

- 1) Remove the elbow cover U.
- 2) Make marks on the seal ring <1> and ring guide <2> with a felt-tip pen so that the position is not deviated.
- 3) Remove the bolts (four M2x2 bolts), and slide the seal ring <1> in the direction of the arrow.
- 4) Apply grease(BARRIERTA IMI/V) onto the surface that the seal ring <1> oil seal contacts using a brush, etc.
- 5) Apply grease onto the surface that the seal ring <1> and seal guide <2>, and tighten the bolts <3>.
- 6) Install the elbow cover U which removed with the above step "1)". In the case of clean specification, take care not to damage the packing attached to the cover matching surface at this time.

This completes the lubrication between wrist housing and forearm.

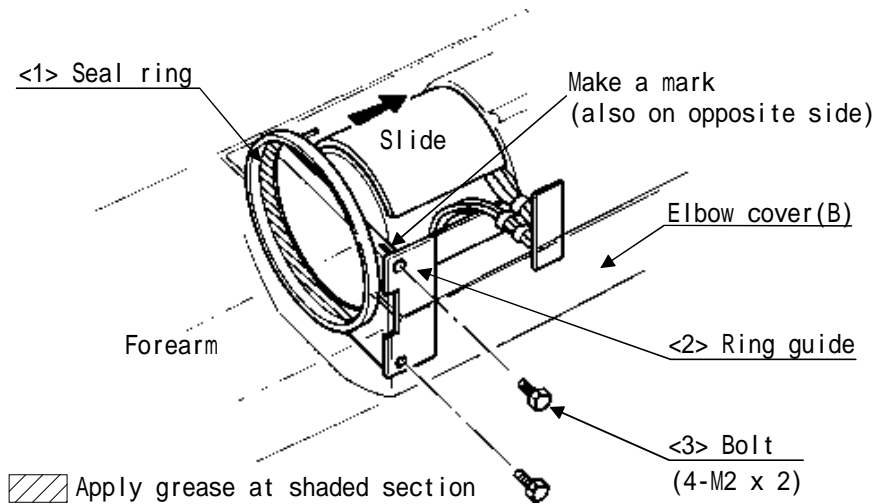

Fig.5-16 : Lubrication between wrist housing and forearm

■ Lubrication to wrist housing end and between elbow block and forearm

Fig. 5-17 shows the procedures for Lubrication to wrist housing end and between elbow block and forearm. Refer to the "5.3.2Installing/removing the cover" on page 48 and remove the necessary covers.

- 1) Remove the No.2 arm cover U and wrist cover S/U.
- 2) Remove the wrist cover L installation screw, and shift the cover in the direction of the arrow
The J6 axis motor cable is passed through the hole of ring <1>. Make sure not to apply excessive force on the cable. The ring <1> is fixed (adhered) to the wrist cover. Make sure not to apply excessive force on the ring <1>.
- 3) Apply grease(BARRIERTA IMI/V) onto the surface that the seal ring <1> oil seal contacts using a brush, etc.
- 4) With the wrist cover L shifted, move the ring <2> in the direction of the arrow, and remove it. (The ring <2> is not adhered)
- 5) Apply grease(BARRIERTA IMI/V) onto the surface that the ring <2> oil seal contacts using a brush, etc.
- 6) Return the ring <2> to the original position. Match the surface that the sponge is attached to the outer side and toward the wrist cover L side as shown in the Fig. 5-17.
- 7) While pressing the ring <2> in the arrow of the direction so that it matches the wrist cover L groove, install the wrist cover L to the original position with the screws (two M3x8 screws).
- 8) While making sure that the ring <1> and ring <2> correctly match the groove, install the wrist cover U to the original position with the screws (two M3x8 screws).
- 9) Install the No.2 arm cover U and wrist cover S/U to the original position. In the case of clean specification, take care not to damage the packing attached to the cover matching surface at this time.

This completes the lubrication to wrist housing end and between elbow block and forearm.

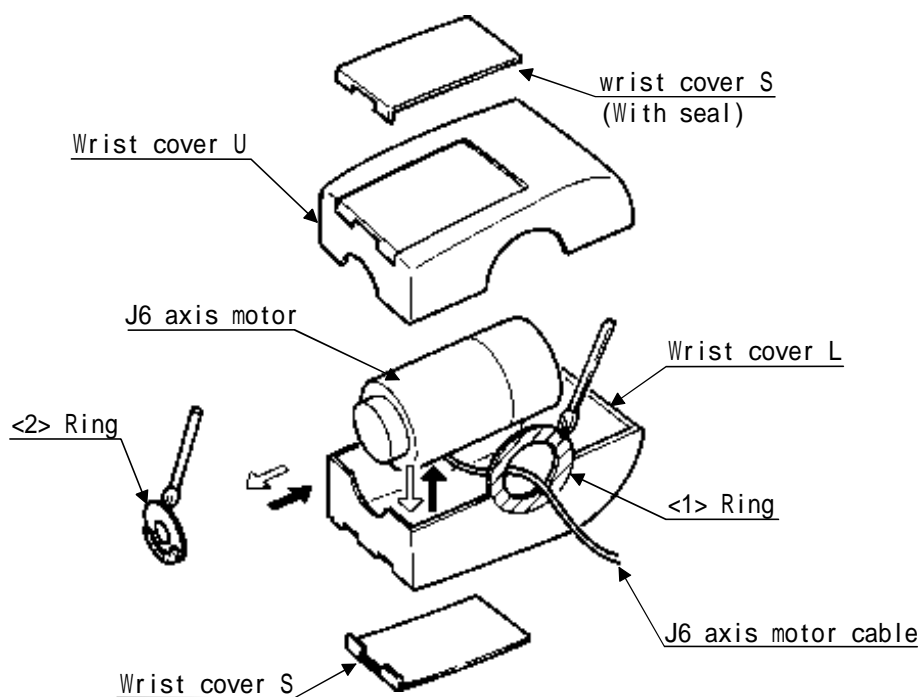

Fig.5-17 : Lubrication to wrist housing end and between elbow block and forearm

5.3.6 How to lubricate the spring shaft area

This robot uses springs for gravity compensation for the J2 axis drive system. The small power consumption of the motor is achieved by connecting spring hooks to the spring shafts set in the J2 axis motor area and J1 axis case, thereby compensating for the gravity by the spring force. Depending on the conditions under which the robot is used, wear may occur due to lack of lubrication in the spring shaft areas. If wear is detected during periodical inspections, it is necessary to apply grease to the two areas shown in Fig. 5-18. Use highly viscous grease (water-soluble types are not allowed). Table 5-5 lists recommended types of grease.

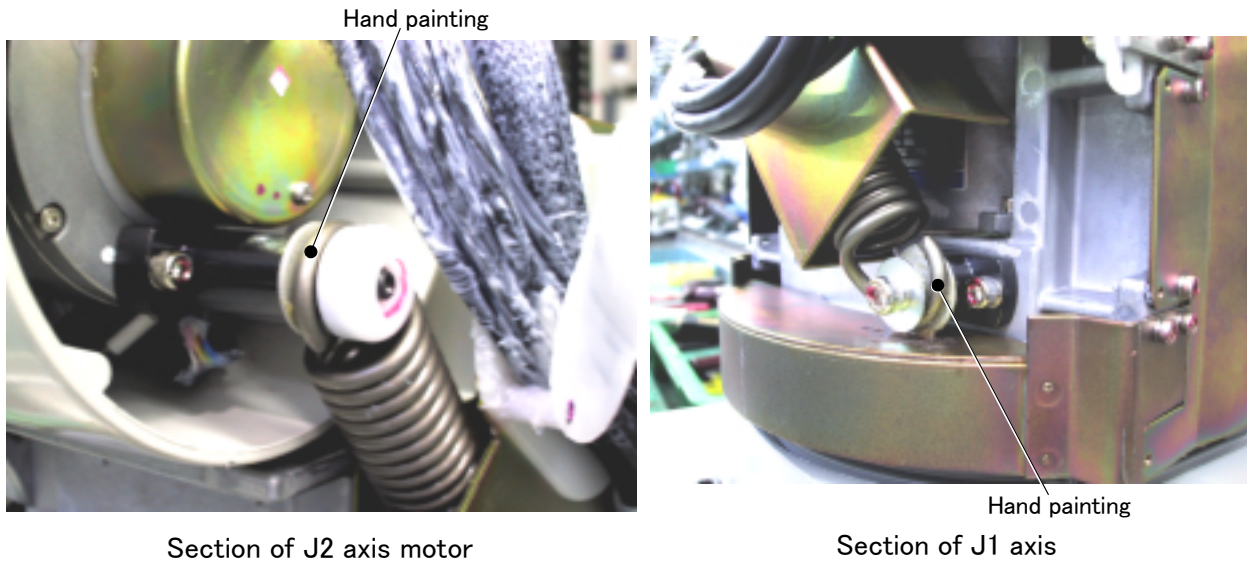

Fig.5-18 : Lubricated points in the spring shaft area

5.3.7 Replacing the backup battery

An absolute encoder is used for the position detector, so the position must be saved with the backup battery when the power is turned OFF. The controller also uses a backup battery to save the program, etc. These batteries are installed when the robot is shipped from the factory, but as these are consumable parts, they must be replaced periodically by the user.

The guideline for replacing the battery is one year, but this will differ according to the robot's usage state. When the battery life nears, the "Battery cumulative time over alarm (Alarm No. 7520)" will occur. Once the alarm occurs, replace all batteries in the robot arm and controller as soon as possible. Lithium batteries (type: A6BAT and ER6) are used in both the controller and robot arm. The procedure of battery replacement of robot arm is explained below.

(1) Replacing the robot arm battery



CAUTION

Don't disconnect connector, etc. While replacing the battery, the encoder position data is saved by the power supplied from the controller. Thus, if the cable connection is incomplete, the encoder position data will be lost when the controller power is turned OFF. Several batteries are used in the robot arm, but replace all old batteries with new batteries at the same time.

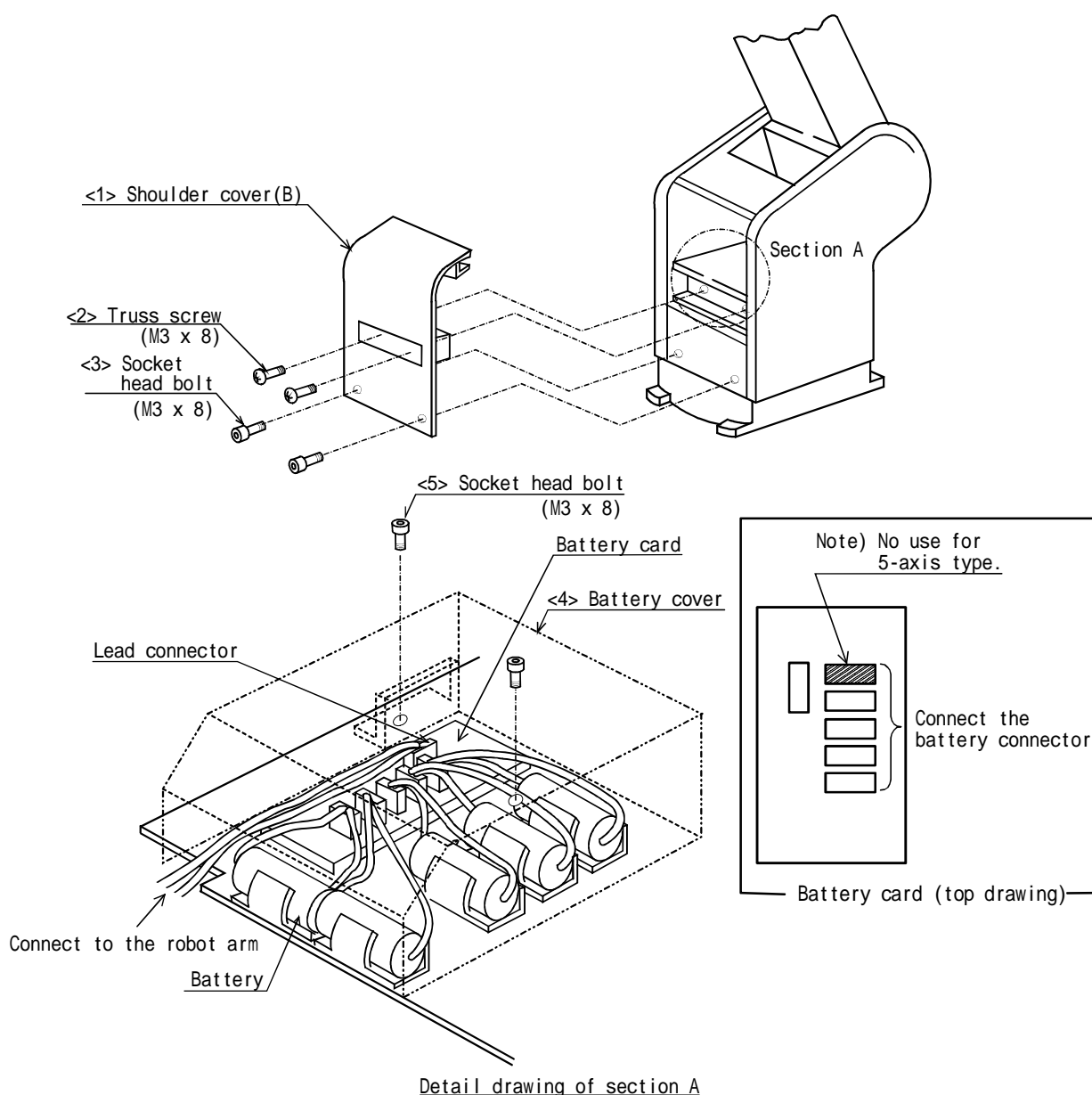

Fig.5-19 : Replacing the battery

- 1) Confirm that the robot arm and controller are connected with a cable.
- 2) Turn the controller control power ON.
The position data is retained by the power supplied from the controller while replacing the battery. Thus, if the cable is not connected correctly, or if the controller power is OFF, the position data will be lost.
- 3) Press the emergency stop button to set the robot in the emergency stop state. This is a measure for safety, and must always be carried out.
- 4) Remove the shoulder cover (B) from the robot. (Refer to ["5.3.2 Installing/removing the cover" on page 48.](#))
- 5) Remove the installation screws <5> in section A of the robot arm, and remove the battery cover <4>.
- 6) The battery holder is located in the battery cover <4>. Remove the old battery from the holder, and disconnect the lead connector.
- 7) Insert the new battery into the holder, and connect the lead connector. Replace all batteries with new ones at the same time.
- 8) Carry out steps "4)" to "5)" in reverse to install the parts.
- 9) Initialize the battery consumption time.
Always carry out this step after replacing the battery, and initialize the battery usage time. Refer to the separate "Instruction Manual/Detailed Explanation of Functions and Operations" for details on the operation methods.

5.4 Maintenance parts

The consumable parts that must be replaced periodically are shown in [Table 5-6](#), and spare parts that may be required during repairs are shown in [Table 5-7](#). Purchase these parts from the dealer when required. Some Mitsubishi-designated parts differ from the maker's standard parts. Thus, confirm the part name, robot arm and controller serial No. and purchase the parts from the dealer.

Table 5-6 : Consumable part list

No.	Part name	Type	Usage place	Q'ty	Supplier
1	Timing belt	B40S2M320U	J5 axis	1	Mitsubishi Electric
2	Grease	SK-1A	Reduction gears of each axis	An needed	
3		BARRIERTA IMI/V	J4,J5,J6 of clean specification	An needed	
4		Shell Alvania Grease No.2	Spring shaft (in base)	An needed	
5	Lithium battery	A6BAT	In battery cover	5-axis type: 4	
				6-axis type: 5	

Table 5-7 : Spare parts list

No.	Part name	Type	Usage place	Q'ty	Supplier
1	AC servo motor		J1 axis	1	Mitsubishi Electric
2			J2 axis	1	
3			J3 axis	1	
4			6-axis type:J4 axis	1	
5			J5 axis	1	
6			J6 axis	1	
7	Reduction gears		J1, J2 axis	2	
8			J3 axis	1	
9			J4, J5 axis (J4 axis is for only 6-axis type)	2	
10			J6 axis	1	
11	Packing(A)	BU147D288H01	Clean specification: elbow cover	An needed	
12	Packing(B)	BU147D288H02	Protection and clean specification: wrist cover	An needed	
13	Packing(C)	BU147D600H01	Clean specification: elbow cover, No.2 arm cover and wrist cover.	An needed	
14	Packing(D)	BU147D600H02	Clean specification: elbow cover and No.2 arm cover.	An needed	
15	Rubber packing	BU147D643H01	Protection specification: No.2 arm cover and wrist cover.	An needed	
16	Silicon seal	KE-4898T	Clean specification: elbow bushing	An needed	

Note) Confirm the robot arm serial No., and contact the dealer for the type.

5.5 Resetting the origin

The origin is set so that the robot can be used with a high accuracy. After purchasing the robot, always carry out this step before starting work. The origin must be reset if the combination of robot and controller being used is changed or if the motor is changed causing an encoder area. The types of origin setting methods are shown in [Table 5-8](#).

Table 5-8 : Origin setting method

No	Method	Explanation	Remarks
1	Origin data input method	The origin data set as the default is input from the T/B.	The setting method is explained in "2.3Setting the origin" on page 11 .
2	Mechanical stopper method	This origin posture is set by contacting each axis against the mechanical stopper.	The setting method is explained in "5.5.1Mechanical stopper method" on page 67 .
3	Jig method	The origin posture is set with the calibration jig installed.	The setting method is explained in "5.5.2Jig method" on page 78 .
4	User origin method	A randomly designated position is set as the origin posture.	Before using this method, the origin must be set with the origin data input method or Mechanical stopper method or jig method. The setting method is explained in "5.5.3User origin method" on page 81 .
5	ABS origin method	This method is used when the encoder backup data lost in the cause such as battery cutting.	Before using this method, the origin must be set with the other method with same encoder. The setting method is explained in "5.5.4ABS origin method" on page 83 .

5.5.1 Mechanical stopper method

The method for setting the origin with the transportation jig is explained below.

This operation is carried out with the T/B. Set the [MODE] switch on the front of the controller to "TEACH", and set the T/B [ENABLE/DISABLE] switch to "ENABLE" to validate the T/B. Move the J4 axis to the upper end with jog operation beforehand.

(1) Select the T/B

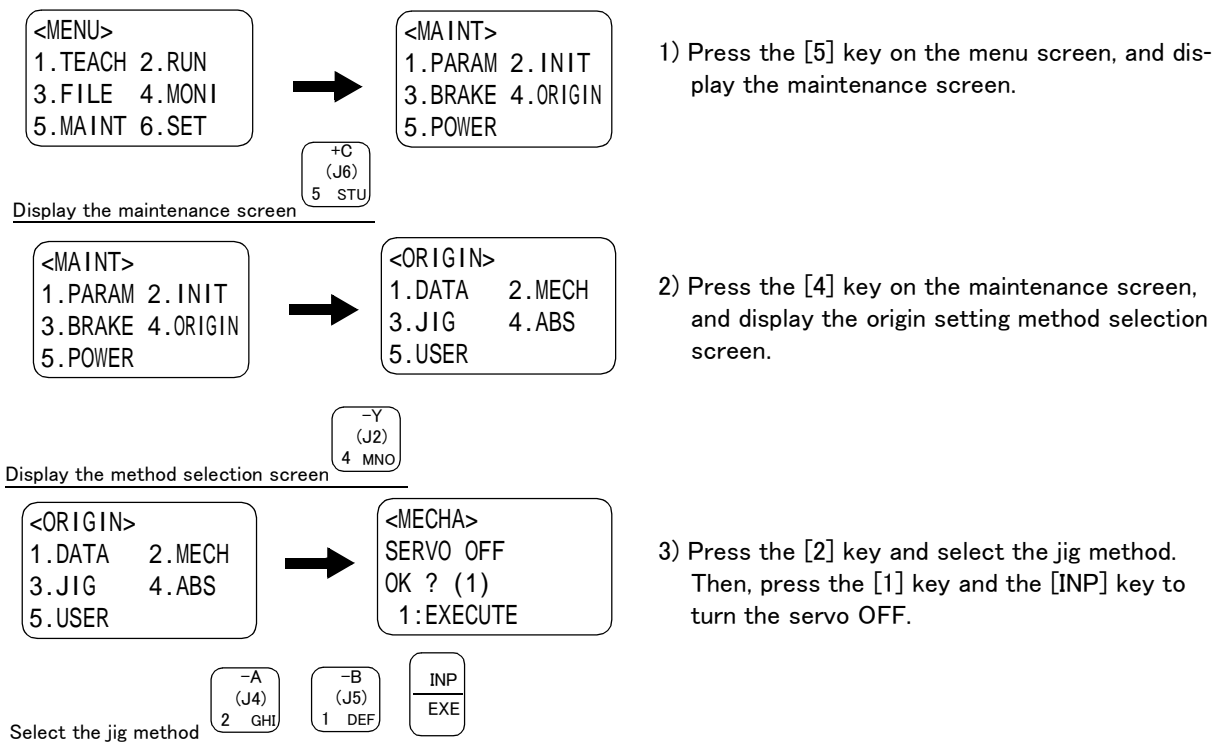

When setting the origin, all axes can be set, or only random axes can be set.

The methods corresponding to the axes to be set are described below, so select the corresponding explanation and set the origin.



CAUTION

The brakes are released here, and the arm is moved with both hands. For safety purposes, the brakes must be released by two workers.

(2) J1 axis origin setting

```
<MECHA> 12345678
BRAKE (10000000)
SET AXIS (11101000)
ORIGIN :NOT DEF
```

Release the brakes

```
-B
(J5)
1 DEF
```

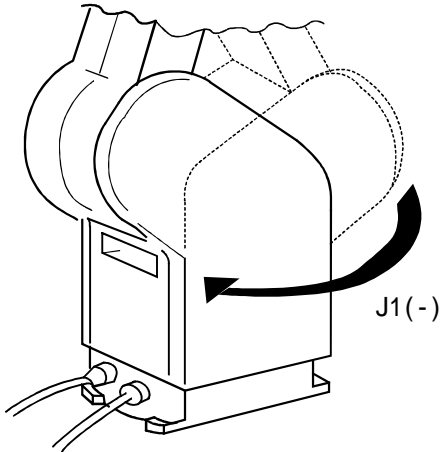

J1(-)

```
RPL
↓
```

Move the cursor

```
<MECHA> 12345678
BRAKE (10000000)
SET AXIS (10000000)
ORIGIN :NOT DEF
```

Designate the origin setting axis

```
-B (J5) 1 DEF
-C (J6) 0 ABC
INP
EXE
```

```
<MECHA>
SET ORIGIN
OK?(1)
1:EXECUTE
```

Set the origin

```
-B (J5) 1 DEF
INP
EXE
```

```
<MECHA> 12345678
BRAKE (10000000)
SET AXIS(10000000)
ORIGIN :COMPLETED
```

- 1) Press the [1] key. "1" will display at the 1 position to set the brake release.
- 2) Confirm the axis for which the brakes are to be released.
- 3) While holding down the deadman switch, hold down the [MOVE] + [+X] keys. The brakes will be released while the keys are held down.
- 4) With both hands, slowly move the J1 axis in - (minus) direction, and contact the axis against the mechanical stopper.
- 5) Press the [↓] key. The cursor will move to "SET AXIS".
- 6) Designate the axis for which the origin is to be set. Set "1" for the 1 axis, and set "0" for the other axes. Then, press [INP]. Next, a confirmation screen will appear.
- 7) Press the [1] and [INP] keys. The origin posture will be set.
- 8) Setting of the origin is completed.
- 9) Refer to "5.5.5 Recording the origin data" on page 84 in this manual, and record the origin data on the origin data seal.

◆◆◆ Releasing the brakes ◆◆◆

To release the brakes, move the cursor to the "BRAKE" axis No. with the [←] or [→] key. The brakes can be released only for the axis for which a "1" is displayed on the screen. If the brakes are not to be released, press the [0] key and display a "0". If the [+X] key on the teaching pendant or the deadman switch is pressed while the brakes are released, the brakes will be applied immediately.

◆◆◆ Origin setting axis designation ◆◆◆

Move the cursor to the "SET AXIS" axis No. in the origin setting with the [←] or [→] key. The origin is set only for the axis for which a "1" is displayed on the screen. If the origin is not to be set, press the [0] key and display a "0".

(3) J2 axis origin setting

```
<MECHA> 12345678
BRAKE (01000000)
SET AXIS (11101000)
ORIGIN :NOT DEF
```

```
-B
(J5)
1 DEF
```

Designate the origin setting axis

- 1) Press the [0] key and then press the [1] key. "1" will display at the 2 position to set the brake release.
- 2) Confirm the axis for which the brakes are to be released.

- 3) One worker must securely support the upper arm with both hands.

- 4) While holding down the deadman switch, hold down the [MOVE] + [+X] keys. The brakes will be released while the keys are held down.
- 5) With both hands, slowly move the J2 axis in - (minus) direction, and contact the axis against the mechanical stopper.

CAUTION

For safety purposes, the step for releasing the brakes must be carried out by two workers. One worker must operate the T/B, and the other must support the arm. When the brakes are released, the robot arm could drop by its own weight depending on the posture.

CAUTION

If the T/B [+X] key or the deadman switch is released, the brakes will be applied immediately.

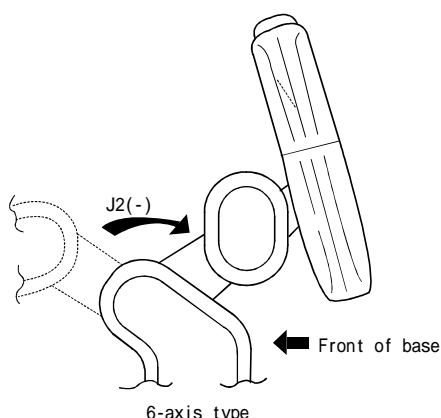
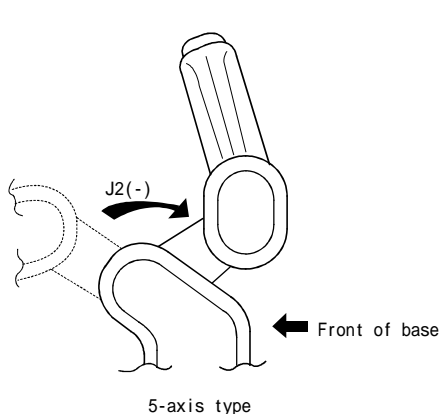

```
RPL
↓
```

Move the cursor

```
<MECHA> 12345678
BRAKE (01000000)
SET AXIS (01000000)
ORIGIN :NOT DEF
```

```
-C (J6) 0 ABC
-B (J5) 1 DEF
INP
EXE
```

Designate the origin setting axis

- 6) Press the [↓] key. The cursor will move to SET AXIS.

```
<MECHA>
SET ORIGIN
OK?(1)
1:EXECUTE
```

```
-B (J5) 1 DEF
INP
EXE
```

Set the origin

- 7) Designate the axis for which the origin is to be set. Set "1" for the 2 axis, and set "0" for the other axes. Then, press [INP]. Next, a confirmation screen will appear.

- 8) Press the [1] and [INP] keys. The origin posture will be set.

```
<MECHA> 12345678
BRAKE (01000000)
SET AXIS(01000000)
ORIGIN :COMPLETED
```

- 9) Setting of the origin is completed.

- 10) Refer to "5.5.5 Recording the origin data" on page 84 in this manual, and record the origin data on the origin data seal.

◆◆◆ Releasing the brakes ◆◆◆

To release the brakes, move the cursor to the "BRAKE" axis No. with the [←] or [→] key.
 The brakes can be released only for the axis for which a "1" is displayed on the screen. If the brakes are not to be released, press the [0] key and display a "0".
 If the [+X] key on the teaching pendant or the deadman switch is pressed while the brakes are released, the brakes will be applied immediately.

◆◆◆ Origin setting axis designation ◆◆◆

Move the cursor to the "SET AXIS" axis No. in the origin setting with the [←] or [→] key.
 The origin is set only for the axis for which a "1" is displayed on the screen. If the origin is not to be set, press the [0] key and display a "0".

(4) J3 axis origin setting

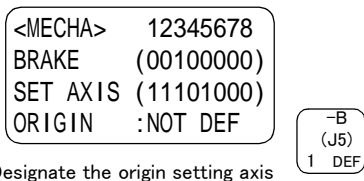

Designate the origin setting axis

- 1) Press the [0] key twice and then press the [1] key. "1" will display at the 3 position to set the brake release.
- 2) Confirm the axis for which the brakes are to be released.
- 3) One worker must securely support the fore arm with both hands.

- 4) While holding down the deadman switch, hold down the [MOVE] + [+X] keys. The brakes will be released while the keys are held down.
- 5) With both hands, slowly move the J3 axis in - (minus) direction, and contact the axis against the mechanical stopper.

CAUTION For safety purposes, the step for releasing the brakes must be carried out by two workers. One worker must operate the T/B, and the other must support the arm. When the brakes are released, the robot arm could drop by its own weight depending on the posture.

CAUTION If the T/B [+X] key or the deadman switch is released, the brakes will be applied immediately.

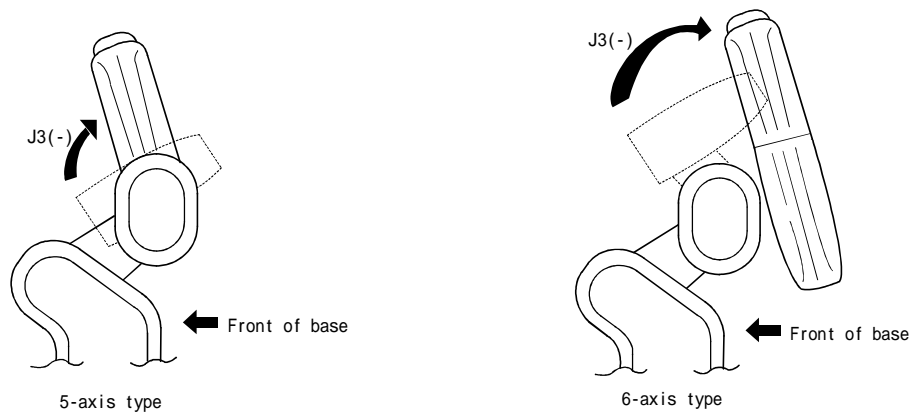

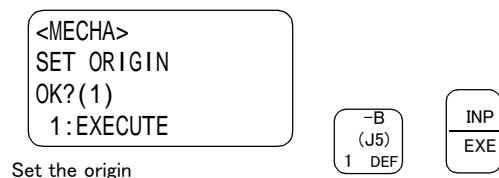
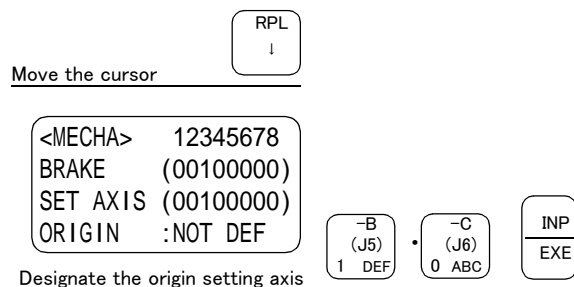

```
<MECHA> 12345678
BRAKE (00100000)
SET AXIS(00100000)
ORIGIN :COMPLETED
```

6) Press the [↓] key. The cursor will move to AXIS.

7) Designate the axis for which the origin is to be set.
Set "1" for the 3 axis, and set "0" for the other axes. Then, press [INP]. Next, a confirmation screen will appear.

8) Press the [1] and [INP] keys.
The origin posture will be set.

9) Setting of the origin is completed.

10) Refer to ["5.5.5 Recording the origin data"](#) on [page 84](#) in this manual, and record the origin data on the origin data seal.

◆◆◆ Releasing the brakes ◆◆◆

To release the brakes, move the cursor to the "BRAKE" axis No. with the [←] or [→] key.

The brakes can be released only for the axis for which a "1" is displayed on the screen. If the brakes are not to be released, press the [0] key and display a "0".

If the [+X] key on the teaching pendant or the deadman switch is pressed while the brakes are released, the brakes will be applied immediately.

◆◆◆ Origin setting axis designation ◆◆◆

Move the cursor to the "SET AXIS" axis No. in the origin setting with the [←] or [→] key.

The origin is set only for the axis for which a "1" is displayed on the screen. If the origin is not to be set, press the [0] key and display a "0".

(5) J4 axis origin setting (Only 6-axis type)

```
<MECHA> 12345678
BRAKE (00100000)
SET AXIS(11111000)
ORIGIN :NOT DEF
```

Designate the origin setting axis

-B
(J5)
1 DEF

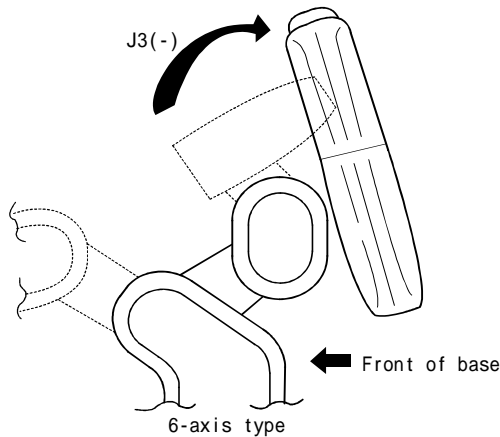

- 1) Before moving the twist axis, move the J3 axis to prevent arm interference.
Press the [0] key twice and then press the [1] key. "1" will display at the 3 position to set the brake release.
- 2) Confirm the axis for which the brakes are to be released.
- 3) One worker must securely support the fore arm with both hands.
- 4) While holding down the deadman switch, hold down the [MOVE] + [+X] keys. The brakes will be released while the keys are held down.
- 5) With both hands, slowly move the J3 axis in - (minus) direction. Stop at a position where the arm will not interfere even if the J4 axis is rotated, and then apply the brakes. Then, set the J4 axis origin.

CAUTION

For safety purposes, the step for releasing the brakes must be carried out by two workers. One worker must operate the T/B, and the other must support the arm. When the brakes are released, the robot arm could drop by its own weight depending on the posture.

CAUTION

If the T/B [+X] key or the deadman switch is released, the brakes will be applied immediately.

```
<MECHA> 12345678
BRAKE (00000000)
SET AXIS(11111000)
ORIGIN :NOT DEF
```

Designate the origin setting axis

-B
(J5)
1 DEF

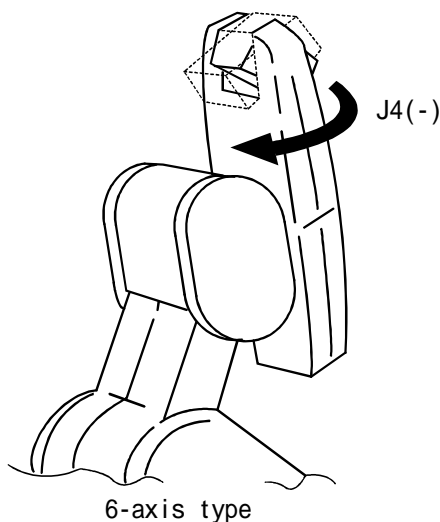

- 6) With both hands, slowly move the J4 axis in - (minus) direction, and contact the axis against the mechanical stopper. The J4 axis does not have a brake.

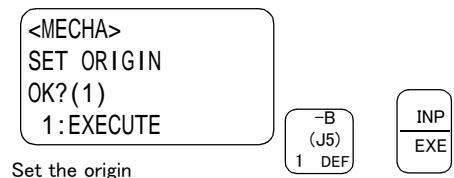
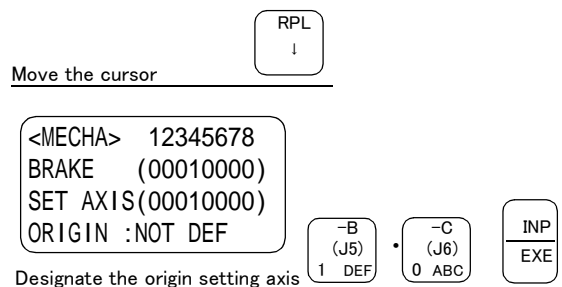

```
<MECHA> 12345678
BRAKE (00010000)
SET AXIS(00010000)
ORIGIN :COMPLETED
```

7) Press the [↓] key. The cursor will move to AXIS .

8) Designate the axis for which the origin is to be set.

Set "1" for the 4 axis, and set "0" for the other axes. Then, press [INP]. Next, a confirmation screen will appear.

9) Press the [1] and [INP] keys.
The origin posture will be set.

10) Setting of the origin is completed.

11) Refer to ["5.5.5Recording the origin data"](#) on [page 84](#) in this manual, and record the origin data on the origin data seal.

◆◆◆ Releasing the brakes ◆◆◆

To release the brakes, move the cursor to the "BRAKE" axis No. with the [←] or [→] key.

The brakes can be released only for the axis for which a "1" is displayed on the screen. If the brakes are not to be released, press the [0] key and display a "0".

If the [+X] key on the teaching pendant or the deadman switch is pressed while the brakes are released, the brakes will be applied immediately.

◆◆◆ Origin setting axis designation ◆◆◆

Move the cursor to the "SET AXIS" axis No. in the origin setting with the [←] or [→] key.

The origin is set only for the axis for which a "1" is displayed on the screen. If the origin is not to be set, press the [0] key and display a "0".

(6) J5 axis origin setting

```
<MECHA> 12345678
BRAKE (00001000)
SET AXIS(11101000)
ORIGIN :NOT DEF
```

Designate the origin setting axis



- 1) Press the [0] key four times and then press the [1] key. "1" will display at the 5 position to set the brake release.
- 2) Confirm the axis for which the brakes are to be released.
- 3) One worker must securely support the wrist arm with both hands.

- 4) While holding down the deadman switch, hold down the [MOVE] + [+X] keys. The brakes will be released while the keys are held down.
- 5) With both hands, slowly move the J5 axis in - (minus) direction, and contact the axis against the mechanical stopper.

CAUTION

For safety purposes, the step for releasing the brakes must be carried out by two workers. One worker must operate the T/B, and the other must support the arm. When the brakes are released, the robot arm could drop by its own weight depending on the posture.

CAUTION

If the T/B [+X] key or the deadman switch is released, the brakes will be applied immediately.

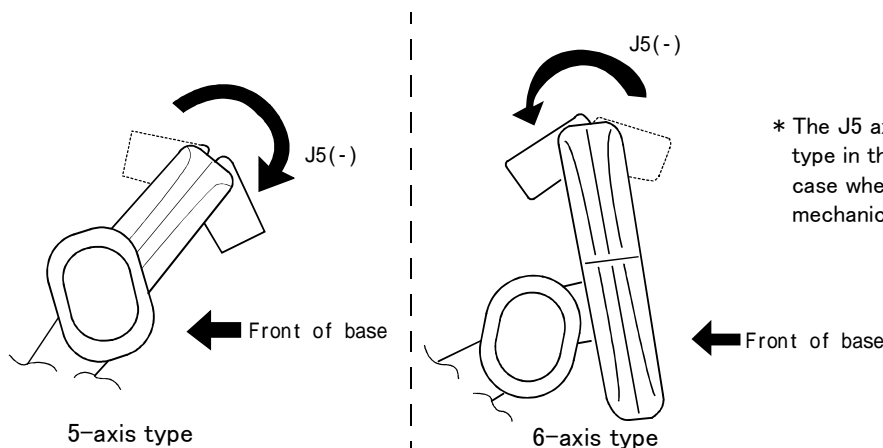

Move the cursor



```
<MECHA> 12345678
BRAKE (00001000)
SET AXIS(00001000)
ORIGIN :NOT DEF
```

Designate the origin setting axis

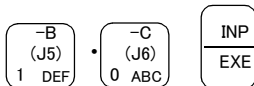

- 6) Press the [↓] key. The cursor will move to SET AXIS.
- 7) Designate the axis for which the origin is to be set. Set "1" for the 5 axis, and set "0" for the other axes. Then, press [INP]. Next, a confirmation screen will appear.

```
<MECHA>
SET ORIGIN
OK?(1)
1: EXECUTE
```

Set the origin

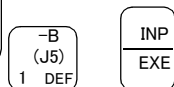

- 8) Press the [1] and [INP] keys. The origin posture will be set.

```
<MECHA> 12345678
BRAKE (00001000)
SET AXIS(00001000)
ORIGIN :COMPLETED
```

- 9) Setting of the origin is completed.
- 10) Refer to "5.5.5 Recording the origin data" on page 84 in this manual, and record the origin data on the origin data seal.

◆◆◆ Releasing the brakes ◆◆◆

To release the brakes, move the cursor to the "BRAKE" axis No. with the [←] or [→] key.

The brakes can be released only for the axis for which a "1" is displayed on the screen. If the brakes are not to be released, press the [0] key and display a "0".

If the [+X] key on the teaching pendant or the deadman switch is pressed while the brakes are released, the brakes will be applied immediately.

◆◆◆ Origin setting axis designation ◆◆◆

Move the cursor to the "SET AXIS" axis No. in the origin setting with the [←] or [→] key.

The origin is set only for the axis for which a "1" is displayed on the screen. If the origin is not to be set, press the [0] key and display a "0".

(7) J6 axis origin setting

```
<MECHA> 12345678
BRAKE (0000100)
SET AXIS(0000100)
ORIGIN :NOT DEF
```

```
-B
(J5)
1 DEF
```

Designate the origin setting axis

1) Install the hand (option) or bolt (two M5 bolts prepared by user) at opposing positions on the mechanical interface.

2) Press the [0] key five times and then press the [1] key. "1" will display at the 6 position to set the brake release.

3) Confirm the axis for which the brakes are to be released.

4) One worker must securely support the upper arm with both hand.

5) While holding down the deadman switch, hold down the [MOVE] + [+X] keys. The brakes will be released while the keys are held down.

6) Hold onto the hand or bolt installed in step 1, and slowly rotate the mechanical interface to the match marks.

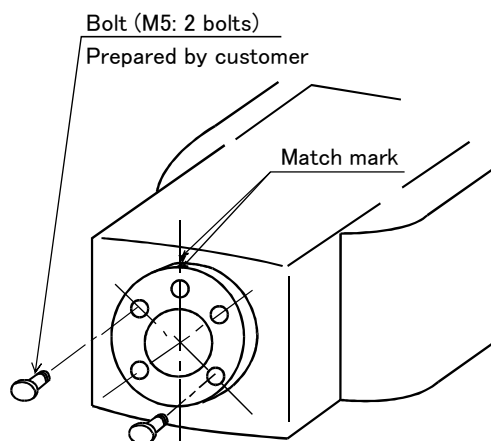

```
RPL
↓
```

Move the cursor

```
<MECHA> 12345678
BRAKE (0000100)
SET AXIS(0000100)
ORIGIN:NOT DEF
```

```
-B
(J5)
1 DEF
```

```
-C
(J6)
0 ABC
```

```
INP
EXE
```

Designate the origin setting axis

⚠ CAUTION

The J6 axis does not have a mechanical stopper. When setting the origin position, do not rotate the axis more than the motion range (± 200deg.).

7) Press the [↓] key. The cursor will move to SET AXIS.

8) Designate the axis for which the origin is to be set. Set "1" for the 6 axis, and set "0" for the other axes. Then, press [INP]. Next, a confirmation screen will appear.

```
<MECHA>
SET ORIGIN
OK?(1)
1:EXECUTE
```

Set the origin

```
-B
(J5)
1 DEF
```

```
INP
EXE
```

```
<MECHA> 12345678
BRAKE (00000100)
SET AXIS(00000100)
ORIGIN:COMPLETED
```

9) Press the [1] and [INP] keys.
The origin posture will be set.

10) Setting of the origin is completed.

11) Refer to ["5.5.5Recording the origin data"](#) on [page 84](#) in this manual, and record the origin data on the origin data seal.

◆◆◆ Releasing the brakes ◆◆◆

To release the brakes, move the cursor to the "BRAKE" axis No. with the [←] or [→] key.

The brakes can be released only for the axis for which a "1" is displayed on the screen. If the brakes are not to be released, press the [0] key and display a "0".

If the [+X] key on the teaching pendant or the deadman switch is pressed while the brakes are released, the brakes will be applied immediately.

◆◆◆ Origin setting axis designation ◆◆◆

Move the cursor to the "SET AXIS" axis No. in the origin setting with the [←] or [→] key.

The origin is set only for the axis for which a "1" is displayed on the screen. If the origin is not to be set, press the [0] key and display a "0".

(8) All axis origin setting

1) Refer to the one after "(2)J1 axis origin setting" on page 68, and set the origin positions of all axis.

The following steps for setting each axis are carried out simultaneously with the other axes, so they can be skipped here.

2) When completed with all work, the robot posture should be as bellow.

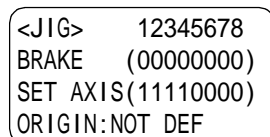
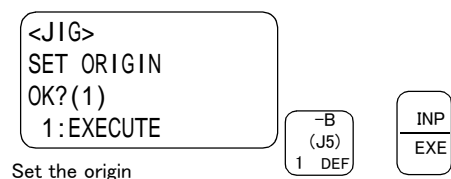
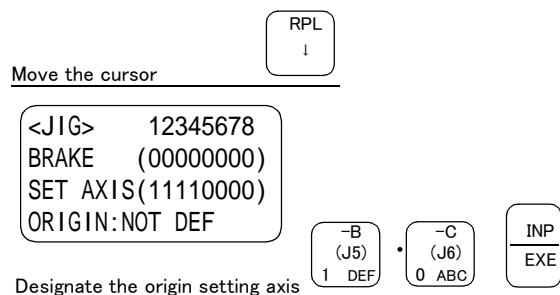
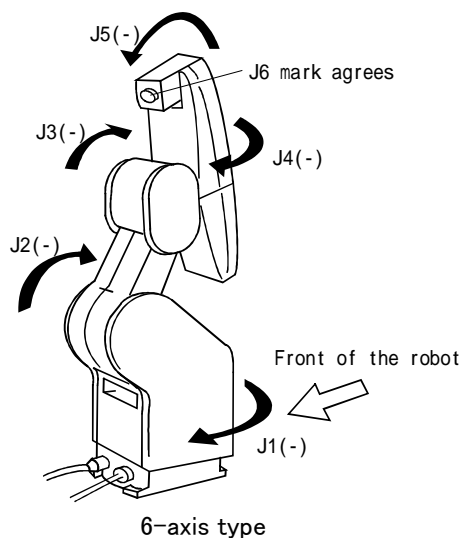
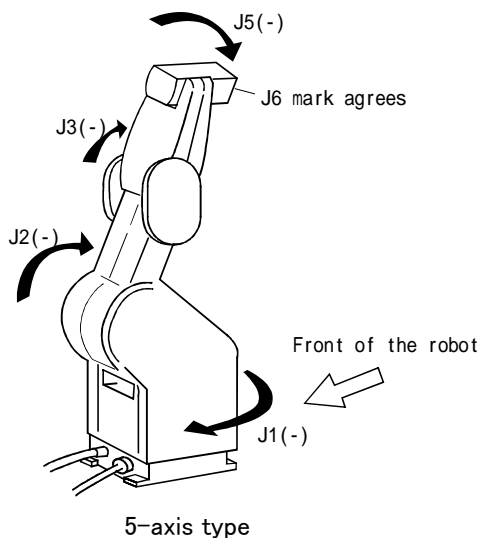

3) Press the [↓] key. The cursor will move to SET AXIS .

4) Designate the axis for which the origin is to be set.

Set 1 to 6 of "SET AXIS" to "1" and then press the [INP] key. The 5-axis robot does not have the 4 axis, so set 0.

Next, a confirmation screen will appear.

5) Press the [1] and [INP] keys. The origin posture will be set.

6) Setting of the origin is completed.

7) Refer to "5.5.5Recording the origin data" on page 84 in this manual, and record the origin data on the origin data seal.

◆◆◆ Releasing the brakes ◆◆◆

To release the brakes, move the cursor to the "BRAKE" axis No. with the [←] or [→] key.

The brakes can be released only for the axis for which a "1" is displayed on the screen. If the brakes are not to be released, press the [0] key and display a "0".

If the [+X] key on the teaching pendant or the deadman switch is pressed while the brakes are released, the brakes will be applied immediately.

◆◆◆ Origin setting axis designation ◆◆◆

Move the cursor to the "SET AXIS" axis No. in the origin setting with the [←] or [→] key.

The origin is set only for the axis for which a "1" is displayed on the screen. If the origin is not to be set, press the [0] key and display a "0".

5.5.2 Jig method

The reference dimension drawing of the calibration jig (1E-INST) used with this method is shown in Fig. 5-20. This jig is the same option as the Mitsubishi RV-E, RV-EN, RV-4A/5AJ/3AL/4AJL Series.

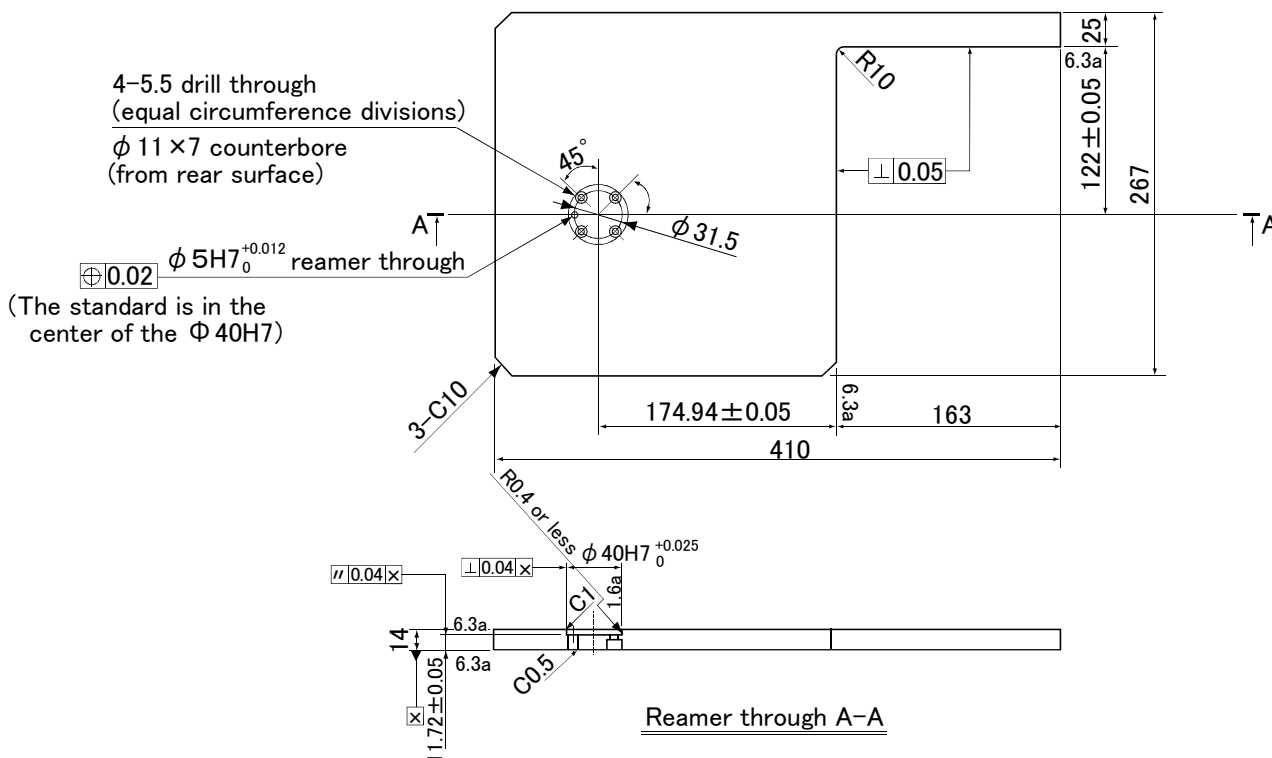
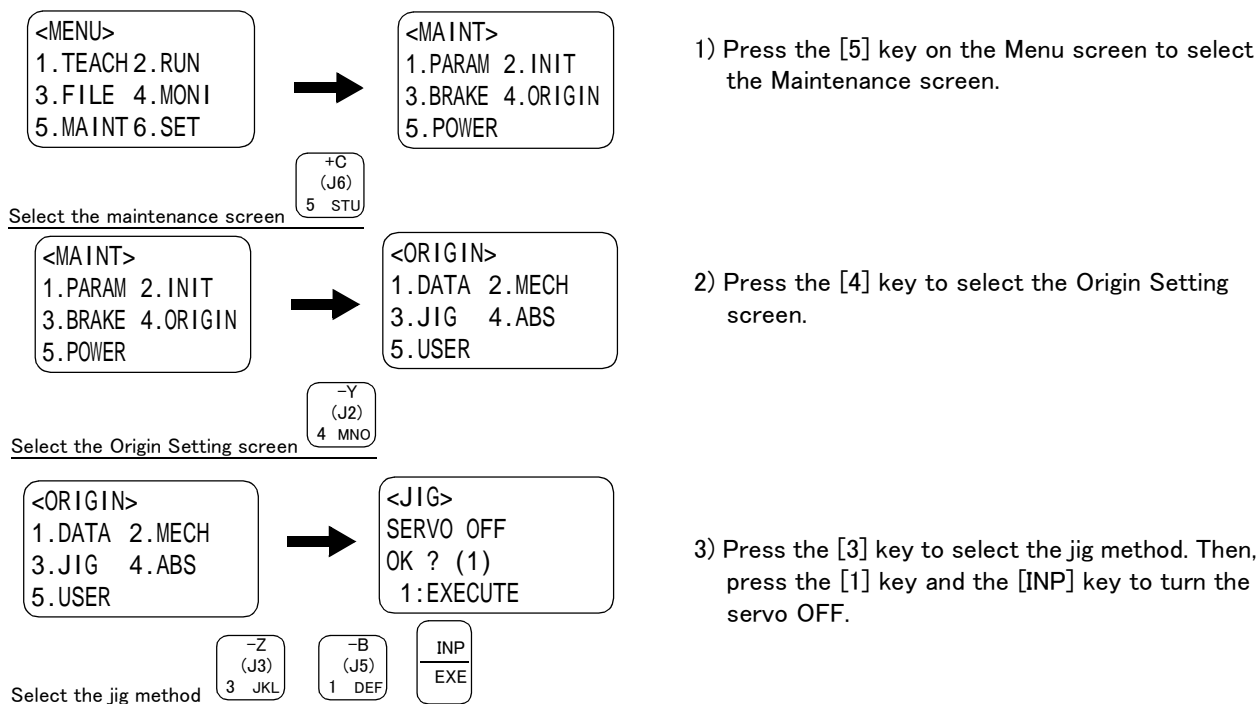
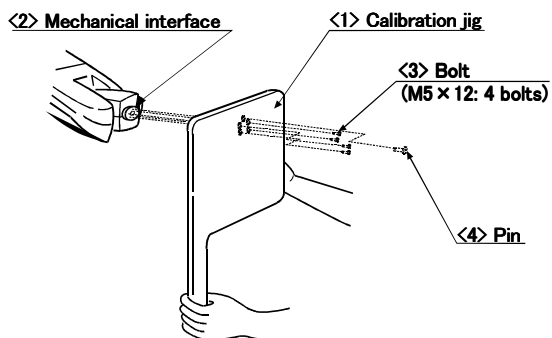

Fig.5-20 : 1E-INST (calibration jig) reference dimension drawing

The procedure of setting the origin with the calibration jig is shown below. This operation is carried out with the teaching pendant. Set the [MODE] switch on the front of the controller to "TEACH", and set the [ENABLE/DISABLE] switch on the teaching pendant to "ENABLE" to enable the teaching pendant.

The following operation is carried out while lightly pressing the deadman switch on the teaching pendant.





- 4) Install the calibration jig <1> on the mechanical interface <2>, and insert the pin <4> to carry out the positioning.
Tighten the bolt <3> in this state and securely fix the jig. After fixing, remove the pin.

5-axis type

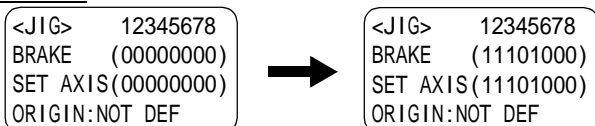

- 5) Designate the axis for which the brakes are to be released.
Press the [1] key three times, the [0] key once, and the [1] key once.

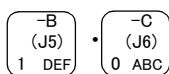

Designate the brakes release axis

6-axis type

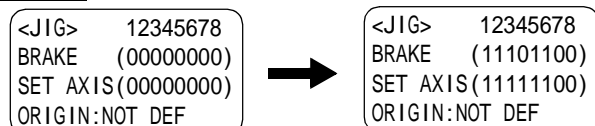

- 6) One worker must hold the calibration jig handle or the robot arm.



Designate the brakes release axis

- 7) While the other worker is holding down the dead-man switch on the teaching pendant, press the [STEP/MOVE] and [+X] key. The brakes will be released only while these keys are held down.

CAUTION

When the brakes are released, the robot arm could drop by its own weight depending on the posture.
If the deadman switch or T/B [+X/+W] key is released, the brakes will be applied immediately.

- 8) Set the robot posture with the brakes released.

Contact the calibration jig against the machined surface on the front and side of the base as bellow.

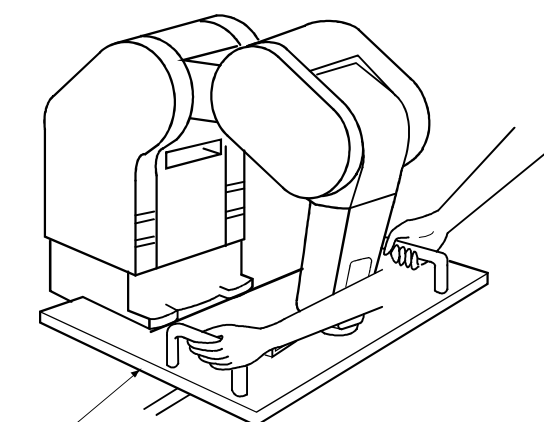

<1> Calibration jig
5-axis type

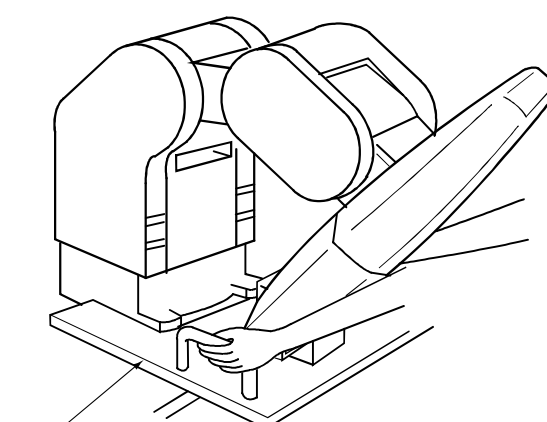

<1> Calibration jig
6-axis type

5-axis type

```
<JIG> 12345678
BRAKE (11101000)
SET AXIS (11101000)
ORIGIN:NOT DEF
```

6-axis type

```
<JIG> 12345678
BRAKE (11101100)
SET AXIS (11111100)
ORIGIN:NOT DEF
```

```
<JIG> 12345678
CHANGES TO ORIGIN
OK? ( )
1:EXECUTE
```

-B (J5)	INP
1 DEF	EXE

Set the origin

5-axis type

```
<JIG> 12345678
BRAKE (11101000)
SET AXIS (11101000)
ORIGIN:NOT DEF
```

6-axis type

```
<JIG> 12345678
BRAKE (11101100)
SET AXIS (11111100)
ORIGIN:NOT DEF
```

9) Set the origin.

Press the [↓] key and move the cursor to "SET AXIS". To set the origin, set "1". Set "0" for the axis for which the origin is not to be set. When 0 is set, the previously set data will be saved.

10) Press the [1] and [INP] keys.

The origin posture will be set.

11) Setting of the origin is completed.

12) Refer to ["5.5.5Recording the origin data"](#) on [page 84](#) in this manual, and record the origin data on the origin data seal.

This completes the setting of the origin with the jig method.

5.5.3 User origin method

**CAUTION**

Before using this method, the origin must be set with the origin data input method or Mechanical stopper method or jig method.

The procedure for setting the origin with the user origin method is explained below.

This operation is carried out with the teaching pendant. Set the [MODE] switch on the front of the controller to "TEACH", and set the [ENABLE/DISABLE] switch on the teaching pendant to "ENABLE" to enable the teaching pendant.

The operation method is shown below.

When setting the origin for the first time using this method, carry out the operations in order from step 1). For the second and following time, move the robot arm to the user origin position with jog operation, and accurately position all axes. Then start the procedure from step 4).

1) Determine the user origin position

Move the robot to the position to be set as the origin with jog operation. Refer to "2.4 Confirming the operation" on page 17 for details on the jog operation.

**CAUTION**

Choose the user origin position as the position where it doesn't move by the gravity. This position is left as a guideline to position all axes with jog operation when setting the origin again with this method.

2) Enter the JOINT jog mode, and display the joint coordinates on the teaching pendant screen. Record the value of the axis for which the origin is to be set.

3) Input the value recorded in the "user designated origin parameter (USERORG)".

The parameter details and input methods are described in the separate "Instruction Manual/Detailed Explanation of Functions and Operations". Refer to that manual and input the user designated origin position.

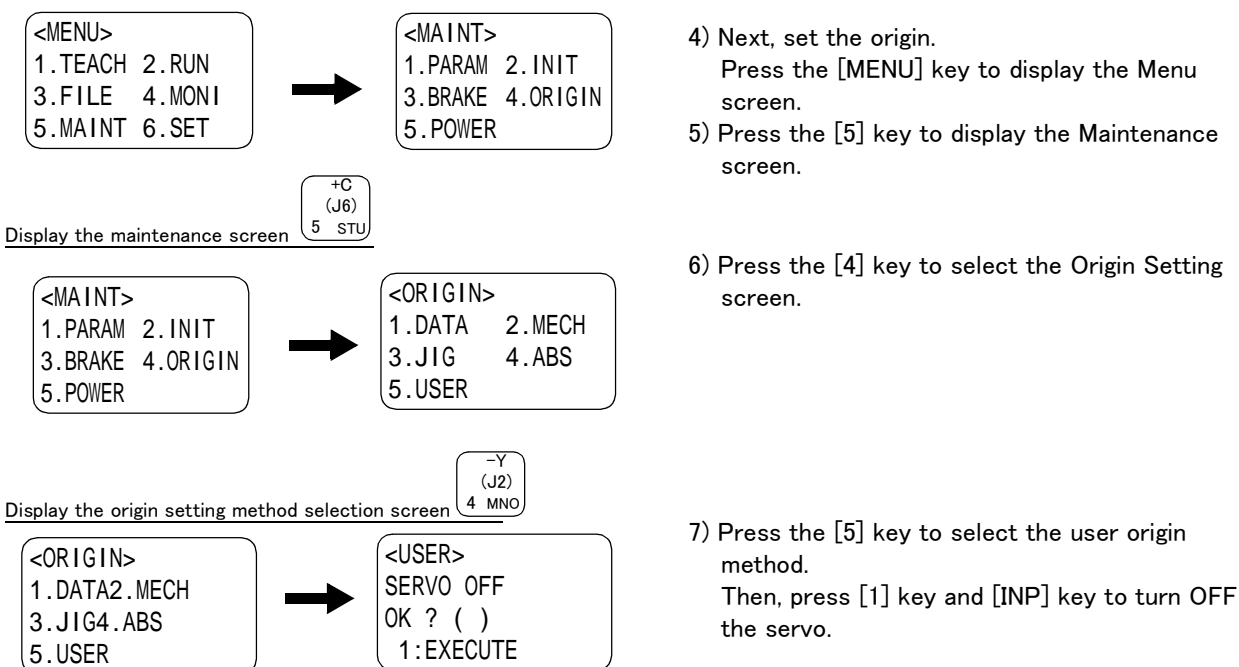

4) Next, set the origin.

Press the [MENU] key to display the Menu screen.

5) Press the [5] key to display the Maintenance screen.

6) Press the [4] key to select the Origin Setting screen.

7) Press the [5] key to select the user origin method.

Then, press [1] key and [INP] key to turn OFF the servo.

<USER> 12345678
BRAKE (00000000)
SET AXIS (11111100)
ORIGIN:NOT DEF

→

<USER>
CHANGES TO ORIGIN
OK?()
1:EXECUTE

8) Press the [↓] key, and input "1" for the axis for which the origin is to be set. Press the [INP] key to display the Confirmation screen.



<USER>
CHANGES TO ORIGIN
OK?(1)
1:EXECUTE

→

<USER>12345678
BRAKE (00000000)
SET AXIS(11111100)
ORIGIN :NOT DEF

9) Press the [1] key and then the [INP] key. The origin will be set

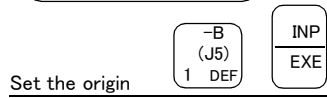

This completes the setting of the origin with the user origin method.

5.5.4 ABS origin method

When the origin setting of the robot is performed for the first time, this product records the angular position of the origin within one rotation of the encoder as the offset value. If the origin setting is performed according to the ABS origin method, this value is used to suppress variations in the origin setting operations and to reproduce the initial origin position accurately.

The procedures for setting the origin with the ABS method are explained below.

(1) Select the T/B

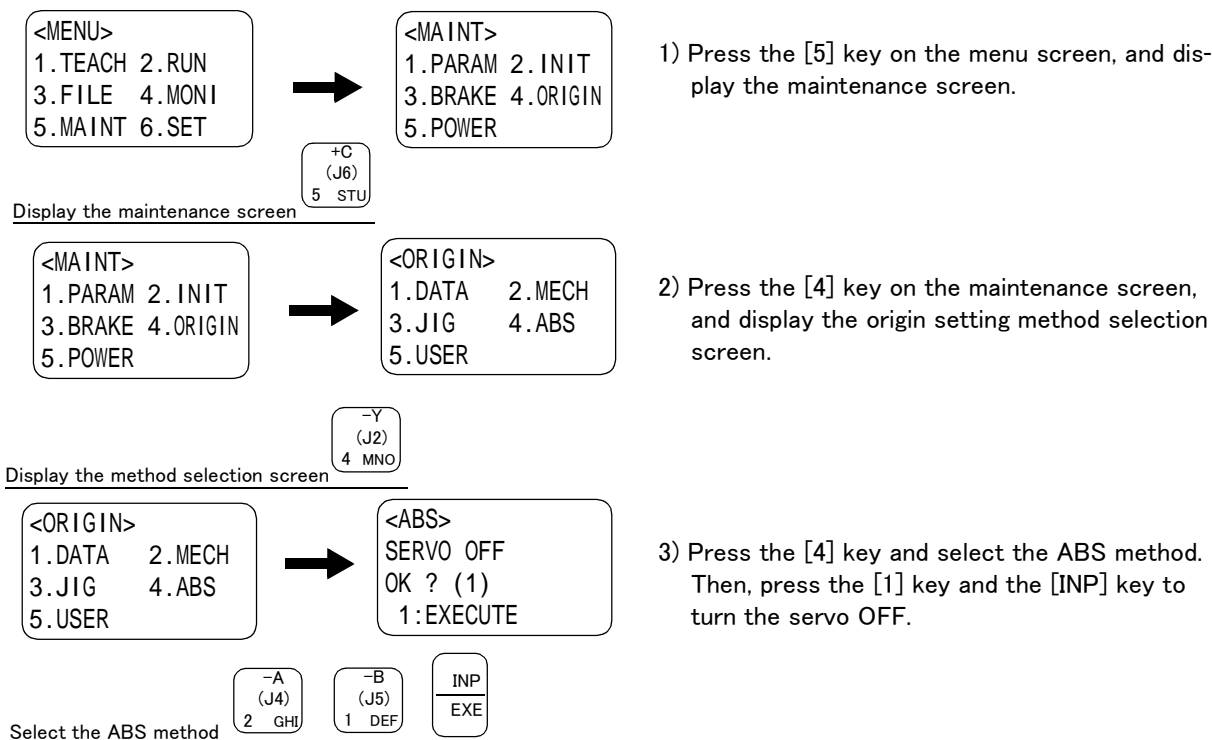

The origin of each axis can be set in the same manner as described in ["5.5.1 Mechanical stopper method"](#) on page 67. ["\(2\) J1 axis origin setting"](#) on page 68 and succeeding sections for how to set the origin for each axis.

When setting the origin, all axes can be set, or only random axes can be set.

The methods corresponding to the axes to be set are described below, so select the corresponding explanation and set the origin.



CAUTION The brakes are released here, and the arm is moved with both hands. For safety purposes, the brakes must be released by two workers.

5.5.5 Recording the origin data

When the origin has been set with the jig method, record that origin data on the origin data label. With this, the origin can be set with the origin data input method the next time.

Confirm the origin data on the teaching pendant screen (origin data input screen). The origin data label is enclosed with the arm or attached on the back of the shoulder cover (B).

The teaching pendant operation method and shoulder cover (B) removal method for confirming the origin data is the same as the methods for setting the origin with the origin data input method. Refer to [“2.3.2 Setting the origin with the origin data input method” on page 12](#), and write the origin data displayed on the teaching pendant onto the origin label.

(1) Confirming the origin data label

Remove the shoulder cover (B).

Refer to [“5.3.2 Installing/removing the cover” on page 48](#), and remove the shoulder cover (B).

(2) Confirming the origin data

Confirm the value displayed on the teaching pendant's Origin Data Input screen.

Refer to [“2.3.2 Setting the origin with the origin data input method”“\(5\) Inputting the origin data”](#), and display the Origin Data Input screen on the teaching pendant display screen.

(3) Recording the origin data

Write the origin data displayed on the teaching pendant to the origin data label attached to the back of the shoulder cover (B). Refer to [“Fig. 2-8 Origin data label \(an example\)” on page 12](#), and [“Fig. 2-9 Correspondence of origin data label and axis” on page 15](#) for details on the origin data label.

(4) Installing the cover

Install the shoulder cover (B) removed in step [“\(1\) Confirming the origin data label”](#) above.

Refer to [“5.3.2 Installing/removing the cover” on page 48](#), and replace the shoulder cover (B).

This completes the recording of the origin data.

6 Appendix

Appendix 1 : Configuration flag

The configuration flag indicates the robot posture.

For the 6-axis type robot, the robot hand end is saved with the position data configured of X, Y, Z, A, B and C. However, even with the same position data, there are several postures that the robot can change to. The posture is expressed by this configuration flag, and the posture is saved with FL1 in the position constant (X, Y, Z, A, B, C) (FL1, FL2).

The types of configuration flags are shown below.

(1) RIGHT/LEFT

P is center of flange in comparison with the plane through the J1 axis vertical to the ground.

Q is center of J5 axis rotation in comparison with the plane through the J1 axis vertical to the ground.

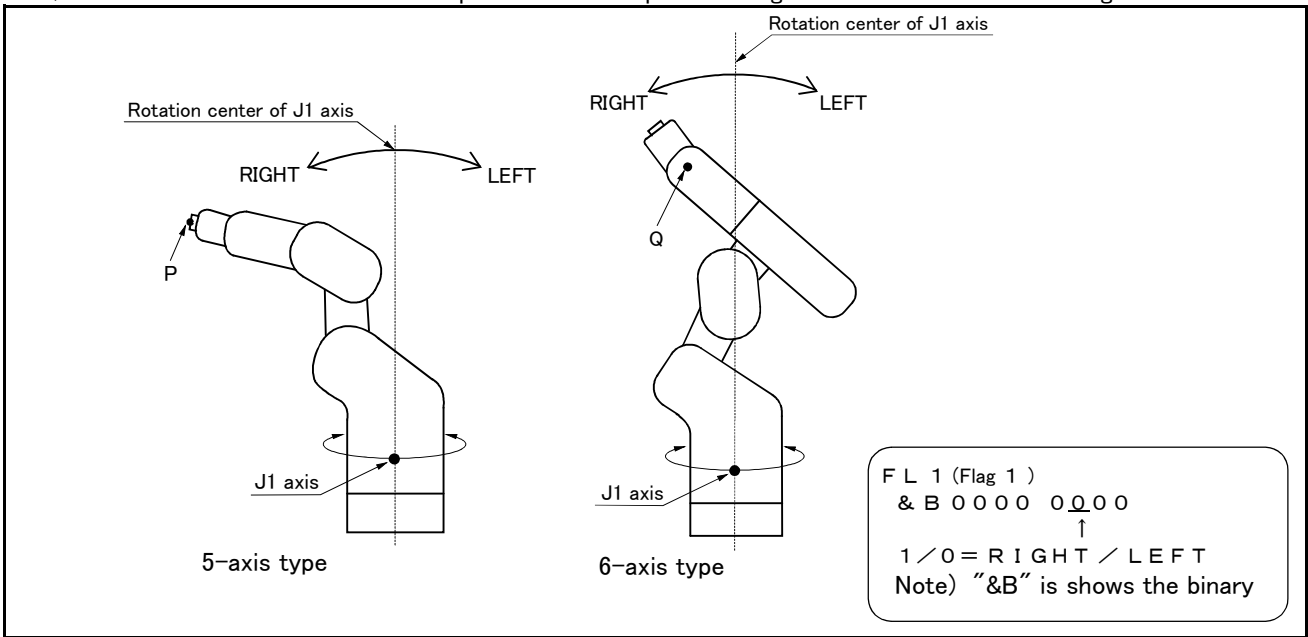

Fig.6-1 : Configuration flag (RIGHT/LEFT)

(2) ABOVE/BELOW

Q is center of J5 axis rotation in comparison with the plane through both the J3 and the J2 axis. .

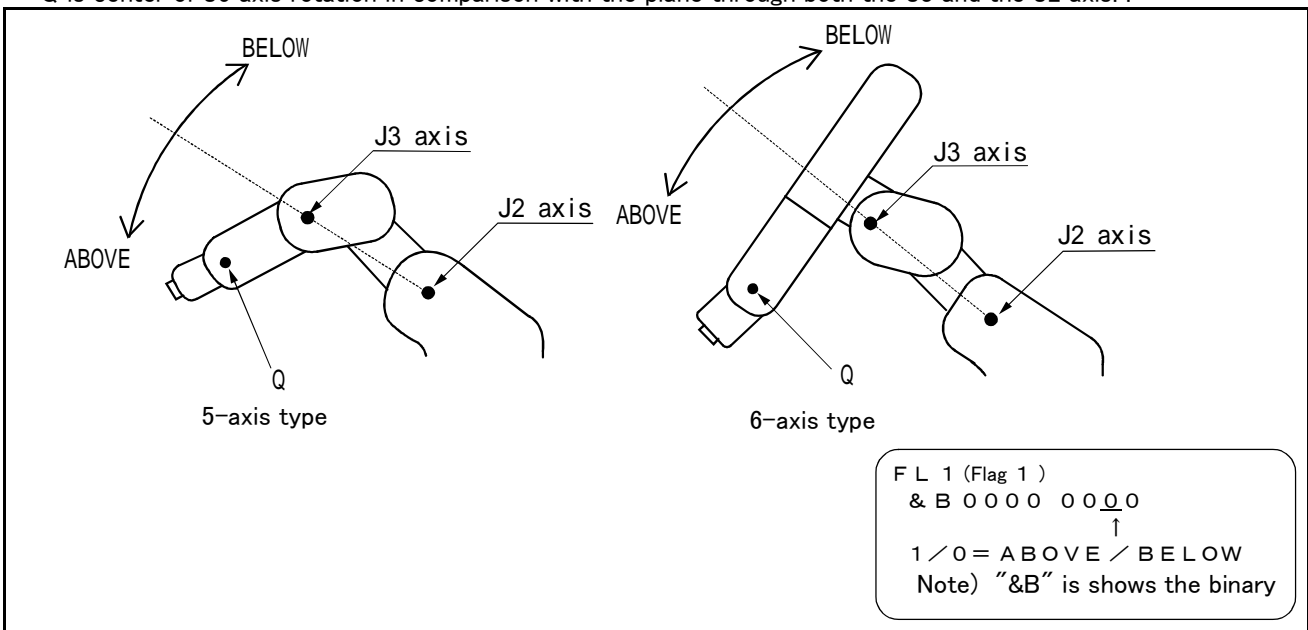

Fig.6-2 : Configuration flag (ABOVE/BELOW)

(3) NONFLIP/FLIP (6-axis robot only.)

This means in which side the J6 axis is in comparison with the plane through both the J4 and the J5 axis..

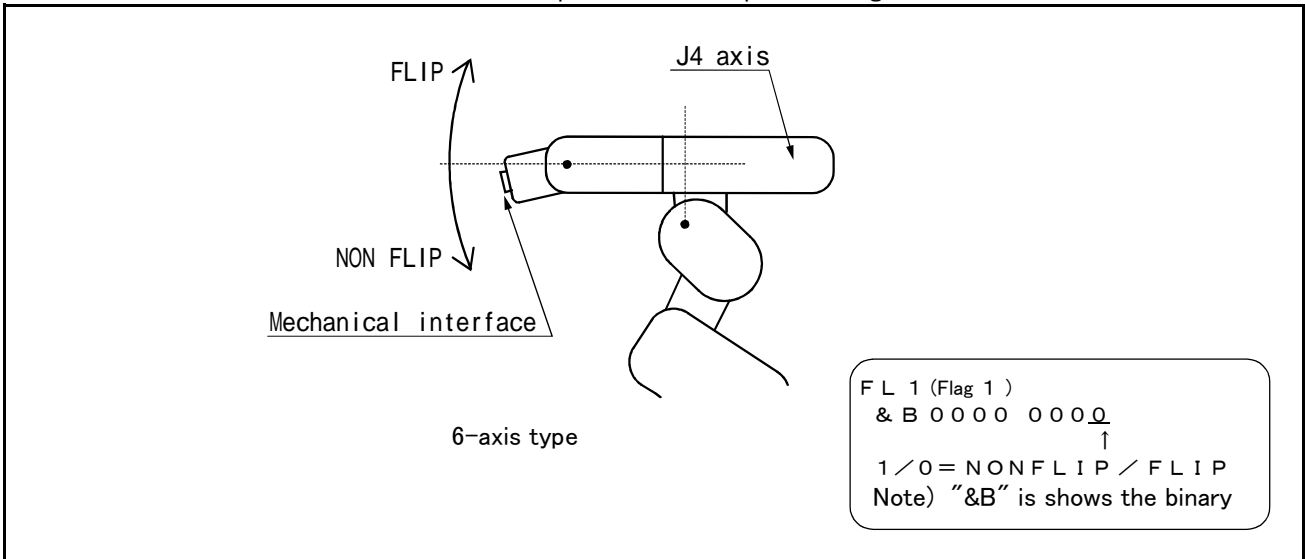

Fig.6-3 : Configuration flag (NONFLIP/FLIP)

HEADQUARTERS

MITSUBISHI ELECTRIC EUROPE
EUROPE B.V.
German Branch
Gothaer Straße 8
D-40880 Ratingen
Phone: +49 (0) 21 02 / 486-0
Fax: +49 (0) 21 02 / 4 86-1120
e mail: megfamail@meg.mee.com

MITSUBISHI ELECTRIC FRANCE
EUROPE B.V.
French Branch
25, Boulevard des Bouvets
F-92741 Nanterre Cedex
Phone: +33 1 55 68 55 68
Fax: +33 1 55 68 56 85
e mail: factory.automation@fra.mee.com

MITSUBISHI ELECTRIC ITALY
EUROPE B.V.
Italian Branch
Via Paracelso 12
I-20041 Agrate Brianza (MI)
Phone: +39 (0) 39 / 60 53 1
Fax: +39 (0) 39 / 60 53 312
e mail: factory.automation@it.mee.com

MITSUBISHI ELECTRIC SPAIN
EUROPE B.V.
Spanish Branch
Carretera de Rubí 76-80
E-08190 Sant Cugat del Vallés (Barcelona)
Phone: +34 9 3 / 565 3131
Fax: +34 9 3 / 589 2948
e mail: industrial@sp.mee.com

MITSUBISHI ELECTRIC UK
EUROPE B.V.
UK Branch
Travellers Lane
GB-Hatfield Herts. AL10 8 XB
Phone: +44 (0) 1707 / 27 61 00
Fax: +44 (0) 1707 / 27 86 95

MITSUBISHI ELECTRIC JAPAN
CORPORATION
Office Tower "Z" 14 F
8-12,1 chome, Harumi Chuo-Ku
Tokyo 104-6212
Phone: +81 3 6221 6060
Fax: +81 3 6221 6075

MITSUBISHI ELECTRIC USA
AUTOMATION
500 Corporate Woods Parkway
Vernon Hills, IL 60061
Phone: +1 847 / 478 21 00
Fax: +1 847 / 478 22 83

EUROPEAN REPRESENTATIVES

GEVA AUSTRIA
Wiener Straße 89
A-2500 Baden
Phone: +43 (0) 2252 / 85 55 20
Fax: +43 (0) 2252 / 488 60
e mail: office@geva.at

Getronics b.v. BELGIUM
Control Systems
Pontbeeklaan 43
B-1731 Asse-Zellik
Phone: +32 (0) 2 / 4 67 17 51
Fax: +32 (0) 2 / 4 67 17 45
e mail: infoautomation@getronics.com

INEA CR d.o.o. CROATIA
Drvinje 63
HR-10000 Zagreb
Phone: +385 (0)1/ 36 67 140
Fax: +385 (0)1/ 36 67 140
e mail: —

AutoCont CZECHIA
Control Systems s.r.o.
Nemocnicni 12
CZ-702 00 Ostrava 2
Phone: +420 (0) 69 / 615 21 11
Fax: +420 (0) 69 / 615 25 62
e mail: consys@autocont.cz

louis poulsen DENMARK
industri & automation
Geminivej 32
DK-2670 Greve
Phone: +45 (0) 43 / 95 95 95
Fax: +45 (0) 43 / 95 95 91
e mail: lpia@lpmail.com

Beijer Electronics OY FINLAND
Ansatie 6a
FIN-01740 Vantaa
Phone: +358 (0) 9 / 886 77 500
Fax: +358 (0) 9 / 886 77 555
e mail: info@beijer.fi

Kouvalias s GREECE
Industrial Robot
25, El. Venizelou Ave.
GR-17671 Kallithea
Phone: +302 (0) 10 / 958 92 43
Fax: +302 (0) 10 / 953 65 14
e mail: robots@acci.gr

Axicont Automatika Kft. HUNGARY
Reitter F. U. 132
H-1131 Budapest
Phone: +36 (0)1 / 412-0882
Fax: +36 (0)1 / 412-0883
e mail: office@axicont.hu

Meltrade Automatika Kft. HUNGARY
55, Harmat St.
HU-1105 Budapest
Phone: +36 (0)1 / 2605 602
Fax: +36 (0)1 / 2605 602
e mail: office@meltrade.hu

EUROPEAN REPRESENTATIVES

MITSUBISHI ELECTRIC IRELAND
EUROPE B.V. – Irish Branch
Westgate Business Park
Ballymount
IRL-Dublin 24
Phone: +353 (0) 1 / 419 88 00
Fax: +353 (0) 1 / 419 88 90
e mail: sales.info@meir.mee.com

Getronics NETHERLANDS
Industrial Automation B.V.
Donauweg 2 B
NL-1043 AJ Amsterdam
Phone: +31 (0) 20 / 587 6700
Fax: +31 (0) 20 / 587 6839
e mail: info.gia@getronics.com

Beijer Electronics AS NORWAY
Teglværksveien 1
N-3002 Drammen
Phone: +47 (0) 32 / 24 30 00
Fax: +47 (0) 32 / 84 85 77
e mail: info@beijer.no

MPL Technology Sp. z o.o. POLAND
ul. Sliczna 36
PL-31-444 Kraków
Phone: +48 (0) 12 / 632 28 85
Fax: +48 (0) 12 / 632 47 82
e mail: krakow@mpl.pl

ACP Autocomp a.s. SLOVAKIA
Chalupkova 7
SK-81109 Bratislava
Phone: +421 (02) / 5292- 22 54/55
Fax: +421 (02) / 5292- 22 48
e mail: info@acp-autocomp.sk

INEA d.o.o. SLOVENIA
Stegne 11
SI-1000 Ljubljana
Phone: +386 (0) 1- 513 8100
Fax: +386 (0) 1- 513 8170
e mail: inea@inea.si

Beijer Electronics AB SWEDEN
Box 426
S-20124 Malmö
Phone: +46 (0) 40 / 35 86 00
Fax: +46 (0) 40 / 35 86 02
e mail: info@beijer.se

ECONOTEC AG SWITZERLAND
Postfach 282
CH-8309 Nürensdorf
Phone: +41 (0) 1 / 838 48 11
Fax: +41 (0) 1 / 838 48 12
e mail: info@econotec.ch

GTS TURKEY
Darülaceze Cad. No. 43A KAT: 2
TR-80270 Okmeydani-Istanbul
Phone: +90 (0) 212 / 320 1640
Fax: +90 (0) 212 / 320 1649
e mail: gts@turk.net

EURASIAN REPRESENTATIVE

Elektrostyle RUSSIA
Ul Garschina 11
RUS-140070 Moscovskaja Oblast
Pos. Tomilino
Phone: +7 095 / 261 3808
Fax: +7 095 / 261 3808
e mail: —

ICOS RUSSIA
Ryazanskij Prospekt, 8A, Office 100
RUS-109428 Moscow
Phone: +7 095 / 232 0207
Fax: +7 095 / 232 0327
e mail: mail@icos.ru

MIDDLE EAST REPRESENTATIVE

ILAN & GAVISH LTD ISRAEL
Automation Service
24 Shenkar St., Kiryat Arie
IL-49001 Petach-Tiqva
Phone: +972 (0) 3 / 922 18 24
Fax: +972 (0) 3 / 924 07 61
e mail: iandg@internet-zahav.net

AFRICAN REPRESENTATIVE

CBI Ltd SOUTH AFRICA
Private Bag 2016
ZAF-1600 Isando
Phone: +27 (0) 11 / 928 2000
Fax: +27 (0) 11 / 392 2354
e mail: cbi@cbi.co.za